

Structuring data to capture energy reticulation knowledge

P Schoeman



orcid.org 0000-0001-8391-0453

Dissertation accepted in fulfilment of the requirements for the degree *Master of Engineering in Development and Management Engineering* at the North-West University

Supervisor: Prof M Kleingeld

Graduation: May 2020

Student number: 25078097

ABSTRACT

Title: Structuring data to capture energy reticulation knowledge.

Author: P Schoeman

Supervisors: Prof. M Kleingeld

School: North-West University, CRCED Pretoria

Degree: Master of Engineering (Development and Management)

Keywords: Energy management, energy reticulation, data structures, knowledge management.

Energy management is essential due to the increase in energy costs and its effects on the environmental footprint of an industrial site. Managing energy is an essential but complicated task. This complexity derives itself from the interactions between industrial processes, large energy reticulation networks and a broad scope of work. Energy reticulation is the network of energy streams that flow through an industrial site. The continuous measurement of energy streams generates data, which quantifies and captures information. This quantified view of the energy reticulation informs the energy manager's decisions. The value-based information needs an additional understanding of the energy reticulation to generate useful knowledge.

A framework that defines and organises each measurement can address this need. Defining and organising data through a data structure improves access to relevant data. The current use of primitive spreadsheets or rigid data structures limits access to the relevant data in an organisation. There is thus a need for a simple solution to improve data access, which does not require specialists. Relevant data will address energy management questions. An adjustable structure is required to provide access to knowledge captured in data because relevance fluctuating attribute. The energy manager must also be able to define data continuously. Energy and knowledge management thus has to guide the development of the framework.

An adjustable data-structuring framework was developed using metadata to make data accessible. Metadata is additional data consisting of terms that describe the value-based data. The use of the developed data structure allows continuous energy audits to be performed. The data structure was made interactive and dynamic through information technology. The required quantified view of the industrial process' energy reticulation was achieved.

The data-structuring framework was used to aid energy managers with the energy management scope. A mining case study was used to verify and validate the data structure's ability to enable energy management. The data structure was built for a complicated compressed air ring. The improved data access led to energy-saving observations worth R 2.6 million.

Continuously defining and organising data improves access to relevant energy management data. The framework was verified and validated using a mining case study. Energy management is enabled by improved access to relevant data.

ACKNOWLEDGEMENTS

Above all, thanks to Jesus Christ to whom my life, work and joy belong, because He is the very source of life, happiness and the reason to work. It is my sincerest hope that this work will reflect some of His glory.

I want to thank ETA-Operations and CRCED Pretoria for the opportunities, experience and exposure to exceptional colleagues, as well as for the financial support.

I would also like to thank Prof Edward Matthews for his leadership and for challenging us towards simplicity.

I am grateful to Prof Marius Kleingeld for asking the difficult questions and for his general support throughout this study.

Dr Andries Gous, who has been a magnificent mentor – his time, effort and technical support leave me greatly indebted.

Dr Walter Booysen has spent a considerable amount of time at the start of this study to not only develop the storyline but the authors' development as a researcher. The technical input and the importance of pragmatic-structures will guide my future career.

Dr Waldt Hamer has both challenged and provided support towards the first colloquium and storyline; his inputs were much valued.

Janine Booysen, Imar Schuin, Wiehan Pelser, Mischan De Jager, Ivan Breedt, Casper Van Zyl and Handré Groenewald also deserve honourable mentions for their support with the study, work and my professional development in general.

Simone Barroso, from Language Matters, assisted with the proofreading of the document. Her input significantly improved the writing quality of the document.

Last, but not least, I would like to thank my dad and family for their support. Waldo Schoeman, I appreciate your time and input sincerely. I would not be where I am today without my support structure, which not only formed me but led me to opportunities like writing this dissertation.

TABLE OF CONTENTS

Abstract	ii
Acknowledgements	iv
Table of contents	v
Additional indices	vi
Chapter 1: Introduction	1
1.1 Introduction	2
1.2 Energy management.....	3
1.3 Energy reticulation	11
1.4 Knowledge capturing through data structuring	18
1.5 Enabling energy management	24
1.6 Need for the study.....	25
1.7 Objectives	27
1.8 Conclusion	29
Chapter 2: Development of solution	31
2.1 Introduction	32
2.2 Compile and organise information.....	33
2.3 Create an adjustable data-structuring framework.....	39
2.4 Enable energy management	47
2.5 Conclusion	50
Chapter 3: Verification and validation	51
3.1 Introduction	52
3.2 Compiled energy reticulation knowledge.....	53
3.3 An adjustable data structure	63
3.4 Enable energy management	72
3.5 Conclusion	82
Chapter 4: Conclusion.....	83
4.1 Summary of study	84
4.2 Recommendations	88
Reference List	89
Appendix A: Platinum Mine A Case study	i

ADDITIONAL INDICES

Table of Figures

Figure 1: Scope of an energy manager	5
Figure 2: Data requirement of the ISO 50001 cycle.....	7
Figure 3: Energy management dependency on data systems	8
Figure 4: Energy reticulation information (Figure 21 shows the detailed version of Ring One’s layout)	12
Figure 5: Understanding energy reticulation.....	13
Figure 6: Data flow process.....	14
Figure 7: Levels of analysis.....	16
Figure 8: Summary	29
Figure 9: Data collection	35
Figure 10: Mass and energy balances	36
Figure 11: SADT method	37
Figure 12: Compile unstructured knowledge summary.....	38
Figure 13: Metadata framework	41
Figure 14: Energy reticulation knowledge.....	42
Figure 15: General data model layout	45
Figure 16: Data-structuring framework summary.....	46
Figure 17: Observe and perform actions	48
Figure 18: Enabling energy management summary	49
Figure 19: Methodology summary	50
Figure 20: Mine A – High-level: electrical distribution	54
Figure 21: Ring One layout	55
Figure 22: Ring Two layout	56
Figure 23: SCADA of MINE A	58
Figure 24: Partial view of the database	61
Figure 25: Energy reticulation data-structure - Mine A.....	63
Figure 26:SADT method resulting example.....	65
Figure 27: Eskom Mega-Flex Periods	68
Figure 28: Unpivoted data	69
Figure 29: Structured data model (Related tables)	70
Figure 30: Balance dashboard	72
Figure 31: Ring One - 2018 profiles versus 2019 profiles.....	73

Figure 32: 11# increase in consumption due to the addition of 11C# pipeline 74

Figure 33: Ring One addition of 11 C# 75

Figure 34: Ring Two - 2018 versus 2019 profiles 76

Figure 35: 14# control valve observation..... 77

Figure 36: Supply pressure versus down-stream pressure..... 78

Figure 37: 12 # flow during blasting shift 79

Figure 38: Level 20 A flow increase, during blasting shift..... 80

Figure 39: Frequency dashboard i

Figure 40: Distribution dashboard ii

Figure 41: Calculation Dashboard iii

List of Tables

Table 1: The need for accessibility	22
Table 2: Classification scheme summary	22
Table 3: Available compressed air ring data.....	59
Table 4: Mine A - Energy reticulation table.....	64
Table 5: Unit conversion table.....	66
Table 6: Data problems.....	66
Table 7: Rolling Calendar.....	67
Table 8: Energy-supplier information.....	68
Table 9: Operational shifts	69
Table 10: DAX calculations	iii
Table 11: Platinum mine A - Compressed air reticulation captured	v

List of Abbreviations

Abbreviation	Description
EnSM	Energy-saving measure
ESCO	Energy services companies
ICT	Information and communication technology
KPI	Key performance indicator
PLC	Programmable logic controller
SCADA	Supervisory, control and data acquisition
SADT	Structured analysis and design technique
DAX	Data analysis expressions
ISO	International Organization for Standardization
UDC	Universal decimal classification
SQL	Structured query language

CHAPTER 1: INTRODUCTION

1.1 Introduction

Energy management is essential due to the increase in energy costs and its effects on the environmental footprint of an industrial site. Managing energy is an essential but complicated task. This complexity derives itself from the interactions between industrial processes, large energy reticulation networks and a broad scope of work.

Energy reticulation refers to the network of energy streams that flow through an industrial site. The continuous measurement of energy streams generates data, which quantifies and captures information. This quantified view of the energy reticulation informs the energy manager's decisions. The value-based information needs an additional understanding of the energy reticulation to produce useful knowledge.

Data management is a challenge due to the knowledge of the many data fields that is required in the context of the industrial process' energy reticulation. The objective is to assist the energy manager in capturing energy reticulation knowledge dynamically to improve energy management. This knowledge has to be captured and related to the data.

A framework that defines and organises each measurement can address the need to structure data. Defining and organising data through a data structure improves access to relevant data. The current use of primitive spreadsheets or rigid data structures limits access to the relevant data in an organisation. There is thus a need for a simple solution to improve data access, which does not require specialists. Access to relevant data will address energy management questions. An adjustable structure is required to provide access to the knowledge captured in data because of the dynamic nature of industrial processes. The energy manager has to define data continuously.

Classification schemes can improve access to information. Information and communication technologies (ICT) allows classification schemes to be related to the data which in turn leads to data accessibility. If the relevant data can then be visualised, observations can be made. These observations should lead to actions which result in the ability to manage energy.

Energy and knowledge management must therefore guide the development of the framework. Energy management must will be understood by understanding the its background and by investigating the analysis of energy reticulation networks. Knowledge management will be looked at by investigating how data can be structured using classification. This should enable the energy manager to access relevant numerical information based on the captured knowledge.

1.2 Energy management

Energy management has become a focus area of most industrial production processes [1]. Historically, energy has not been monitored closely as an input to the production process because energy costs were low. However, the cost of energy has since increased to such an extent that industry has not only become aware of a technical energy efficiency gap but also of an extended energy gap, as identified by Schulze et al [2]. The extended gap and its nature will hence be referred to as an energy management gap throughout this study.

The technical energy efficiency gap refers to the difference between theoretical and actual energy efficiency, where actual efficiency is the result of real-world implementation, while theoretical efficiency is based on the design of the system. Interactions between various processes add to practical limitations that companies must deal with. The energy management gap hence involves the mismanagement of parameters, schedules, people and other operational factors [2]. These inefficiencies add to the cost of energy and thus also to the overheads of industrial processes. While the energy management gap is a focus area of this study, it is necessary to take note of the difference between the aforementioned energy efficiency gaps.

The cost of energy is not the only pressure on industries. The lack of energy efficiency and the associated environmental costs are putting more strain on industries. Environmental factors like carbon emissions are influenced by the use of energy [3,4]. Mismanagement of energy therefore increases environmental costs and places a further strain on industries [2], [5–7]. These factors emphasise the need for energy consumption to be managed to limit numerous costs.

Energy management focuses on using each unit of energy in the most beneficial manner and limiting wastage [1], [2], [6], [8–12]. In other words, every energy unit that is put into a process must result in production. This includes technical adaptations of the process or the improved management of crucial parameters, barring the loss of productivity or the safe operation of the process. Evaluating energy efficiency is critical because it benchmarks consumption and supports decision making. The evaluation of energy efficiency is, however, complicated due to the difficulty of defining interactions across processes [6].

The complex interaction between energy-intensive processes adds to the reduced adoption of more energy-efficient technologies. Various industrial sites have different production processes and different supporting utilities. These differences and the inherent complexity make maintaining a scalable solution to energy management a challenge. The solution needs

to grow with the process or its understanding. Therefore, a systematic approach is required to manage industrial energy usage in the form of energy audits.

Energy audits include the systematic review of energy consumers and suppliers. The flows of various energy streams are understood throughout the process. The goal of this review is to understand which processes are large energy consumers and identify significant process inefficiencies. Various process interactions and technical intricacies make energy audits and energy management complex [2].

The complexity of energy management has seen the introduction of dedicated energy managers or consulting companies to the industry [1]. These parties are not only responsible for identifying potential energy consumption improvements but also for maintaining current operations. Understanding the scope of work of the energy manager will enable the verification and validation of the developed solution. The scope of work and responsibilities of an energy manager are summarised in Figure 1. This scope was derived from a literature review done by Schulze et al which resulted in a framework consisting of the same five elements of an energy management project [2].



Figure 1: Scope of an energy manager

The energy manager has to create a strategy that can be implemented and controlled in an organised and sustainable manner [2]. Strategies must not only improve the operational energy consumption but address risks like production loss, safety and equipment failure. These risks can be attributed to equipment breakdowns, safety incidents, human resource issues, criminal acts or any other operational deviations [13]. Once these risks and hazards have been addressed, the implementation of the strategy commences.

To implement a strategy, the energy manager ought to be competent in managing the technical processes, maintenance schedules and project economics [1]. Strategies will also require the implementation of procedures through coordination with relevant managers and personnel. These procedures include how the strategy is to be monitored and controlled [13].

The control of the strategy must be aided by benchmarks and key performance indicators (KPIs) that are developed from an energy audit [14]. The energy audit depends on an understanding of the available information and data which can be utilised to manage the

process. Procedures, information and data must be organised in a sensible way to ensure sustainable control [15].

The organisation and logistical management of strategies require procedures and tasks to be clearly documented for communication with management. This communication ensures that the strategy is organised, traceable and supportive. In turn, this creates a basis from which training and communication can be initialised [1].

For projects and strategies to be sustainable, a culture of sustainability must be developed. Such a culture of sustainability must motivate site personnel through enough communication, training and the management of the developed procedures and tasks. The role of the energy manager is daunting, especially if there are no systems available to guide the process of sustainably implementing an energy-saving strategy.

Most energy-saving strategies therefore depend on an energy management system (EnMS) [1]. An EnMS attains the goal of gaining the most from every unit of energy by using the organisational and informational structures available for efficient communication within a company [2], [9]. Information and communication technologies facilitate the improved use of EnMSs by aiding in the management of data, which further allows stakeholders to monitor and control processes.

The process data, which is the starting point of an energy audit, allows for the generation of an implementable strategy [2]. One of the arising challenges is to ensure that the appropriate data and information is available to inform future decisions [1]. Different frameworks or standards are available to assist with making these decisions.

Available standard and the dependency on data

Energy management is guided by the ISO 50001 standard, which follows the plan-do-check-act cycle shown in Figure 2 [16]. The standard assists energy managers to initialise the energy-saving process.

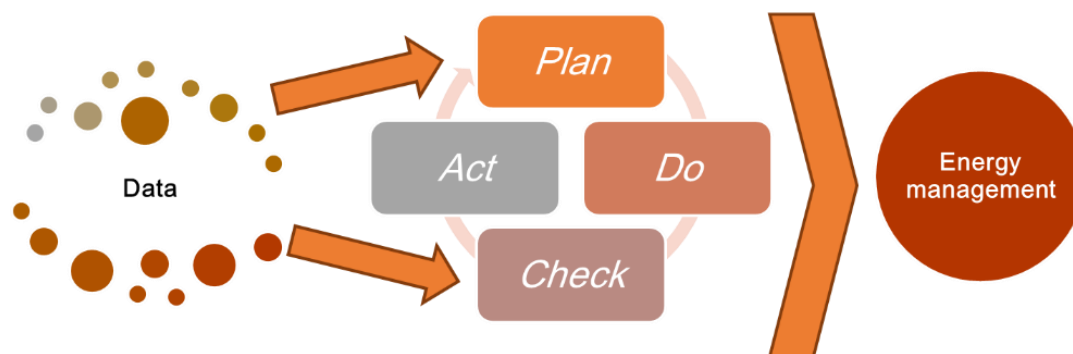

Figure 2: Data requirement of the ISO 50001 cycle

Figure 2 indicates the high-level philosophy of the modern implementation of the ISO 50001 cycle. Data both informs the planned strategy and allows for the control of the strategy by allowing the information to be checked. The implementation and improvement of energy management strategies are improved by making data-driven decisions.

The energy audit process is dependent on the data system because of the requirement for continuous monitoring and reconciliation of energy consumption. The data system thus aids the EnMS to organise and monitor energy management strategies. The use of a data system as part of an EnMS is shown in Figure 3.

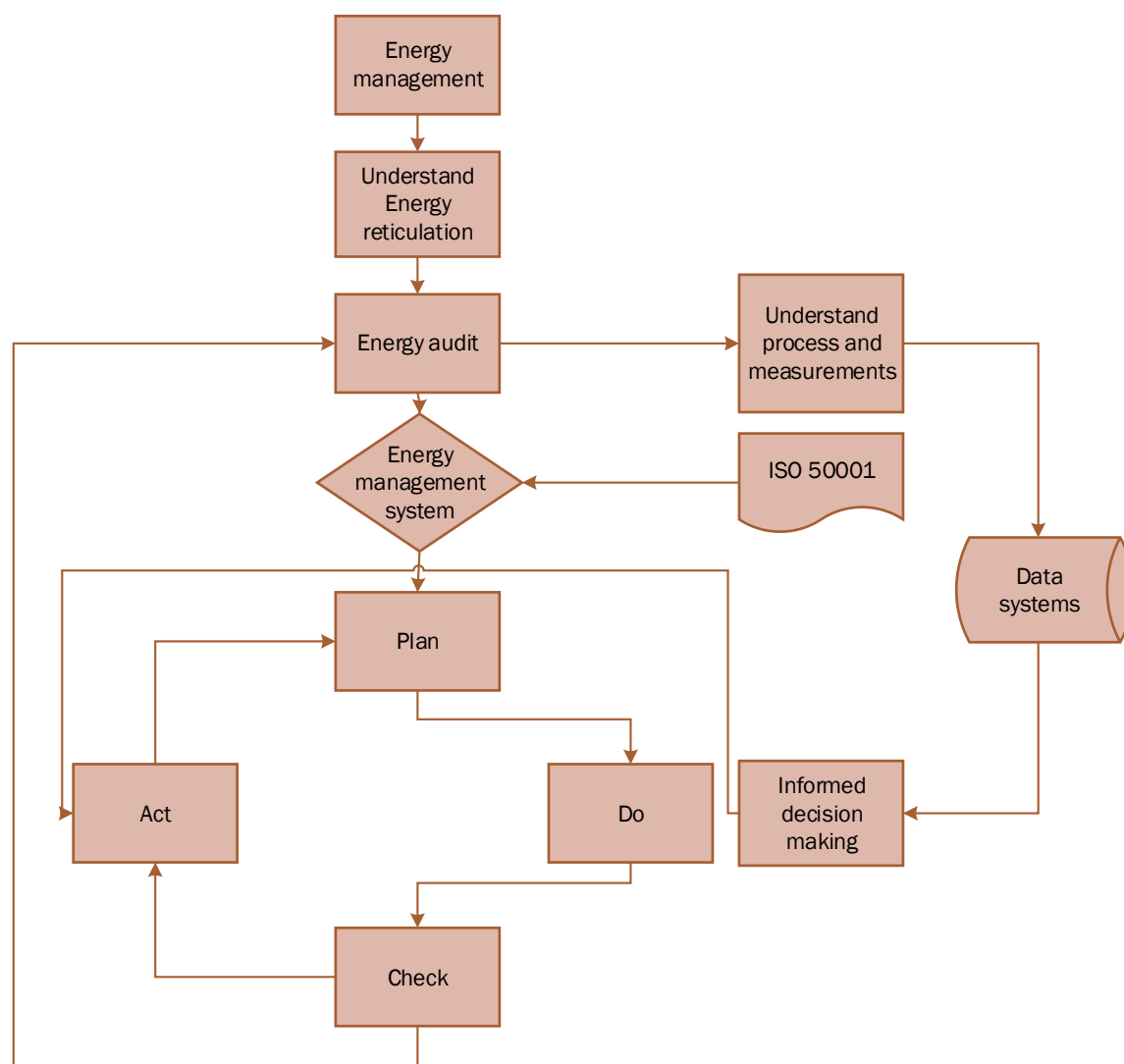

Figure 3: Energy management dependency on data systems

Energy management is dependent on the understanding of the industrial process' energy reticulation. Energy reticulation is the flow of energy through an industrial process from the sources to the consumers. This understanding of energy reticulation is strengthened by an energy audit, which in turn requires an understanding of the process and its measurements. The data from the measurements are collected in a data system, which in turn allows informed decisions to be made regarding the energy management strategies. A data system must, therefore, not only include a database but must also process and report on the data. This means that the data must be converted into useful information.

The ISO 50001 plan-do-check-act cycle can therefore be implemented from the information in the data system. Achieving project sustainability or maintaining an energy saving on a project requires continuous energy audits and analyses [11]. A well-defined data system results in a general framework that makes energy management a less daunting operation.

Energy management challenges

Energy management is dependent on the management of energy-governing factors. These factors include the process layout, energy sources, consumers, mass flow, energy content, production and the distribution of energy and mass through the site [17]. These factors result in many parameters to consider. Increasing the amount of data required to understand the industrial process in enough detail adds to the amount of computational processing that is required. The additional need for the continuous monitoring of a process further adds to the volume of data that must be managed and reported on. The large volumes of data that must be used and managed thus become an additional management burden [18].

For a data system to empower data-driven decisions, the data must first be presented in a sensible report. Reporting is a crucial tool through which to communicate the progress and performance of an energy management strategy [19]. Therefore, the level of analyses required by the target audience must be understood, as it determines which resolutions and aggregations of data are required [20]. A higher resolution of data also adds to the volume of data because more data points are used.

Additionally, the management of the energy-governing factors is qualified by key performance indicators (KPIs). KPIs are difficult to compare because of the various performance requirements of processes across an industrial production process. Defining KPIs is a challenge because of the combination of information that is required to calculate each indicator. Boundary definitions, aggregate levels, different product and energy sources are some problems that feature when working with KPIs. The primary challenge arising from these issues is that KPIs must be comparable and give consideration to interacting effects of processes. As such, these KPIs must also be understood from the perspective of a team of multidisciplinary personnel involved in managing an industrial process [6].

Summary

Energy management is critical due to both energy and environmental costs which relate to energy efficiency and management gaps. The energy manager must consider a broad scope when designing a framework for energy management. The ISO 50001 standard presents a guideline for energy management.

The ISO 50001 standard is dependent on the collection and management of data. A technical understanding of the energy flow through the site ought to be sought and communicated with

the use of the available data to enable efficient energy management. Therefore, an energy management framework must be based on data.

Given the challenges of energy management due to the complex interactions between processes within an industrial site, various parameters and factors must be considered, which result in a large amount of data having to be processed. In addition, defining KPIs and communicating with multidisciplinary personnel add to the challenges faced when implementing energy management.

These considerations are, however, without use without an understanding of the reticulation process.

1.3 Energy reticulation

Energy reticulation is the flow of different energy sources through the process network of an industrial site to the various consumers. These consumers use energy to convert substances of low value to a higher value. Understanding energy reticulation thus entails analysing the flow of energy with an energy audit [11].

Understanding energy reticulation implies having a knowledgeable view of the network of energy that flows through an industrial site. Energy management is enabled through energy reticulation accounting in the form of mass and energy balances. Mass and energy balances are based on the scientific laws of mass and energy preservation. The laws respectively state that mass and energy cannot be created nor destroyed [21]. By these same principles, mass and energy sent into the process must exit the process in some form or another.

The principles of mass and energy balances will thus ensure a sound understanding of the industrial process' energy reticulation. This knowledge can be further validated through the observation of movements in the energy reticulation in association with events that occurred. This practice is founded on the management and analysis of an energy audit using the available data and information.

Data is therefore structured through mass and energy balances. Structured data facilitates an improved understanding of the energy reticulation movements through time. Losses and wastage can be identified because of the additional understanding of the energy reticulation that is generated. The current energy usage can also be compared to a baseline or benchmark that is generated from historical energy usage in order to manage energy consumption [22].

Energy is wasted when more energy is supplied relative to the operating energy demand of the process or when the baseload is large. The baseload refers to the energy required for a system to operate but without resulting in production. Various inefficiencies can add to baseloads, such as leaks on a compressed air network. Baseloads present energy-saving opportunities [22].

A developed understanding of the energy reticulation together with the knowledge of energy management and baseloads helps the energy manager devise strategies for reducing the energy consumption of an industrial process. This is the initial step required toward addressing the energy management gap. Additional sources of information must be consulted in order to understand the energy reticulation and successfully develop mass and energy balances.

Components of an energy reticulation analysis

Drawings, documents, people, events and measurements give insight into the flow of energy through a site, as shown in Figure 4. These sources are also the typical media through which the understanding of the site is communicated.

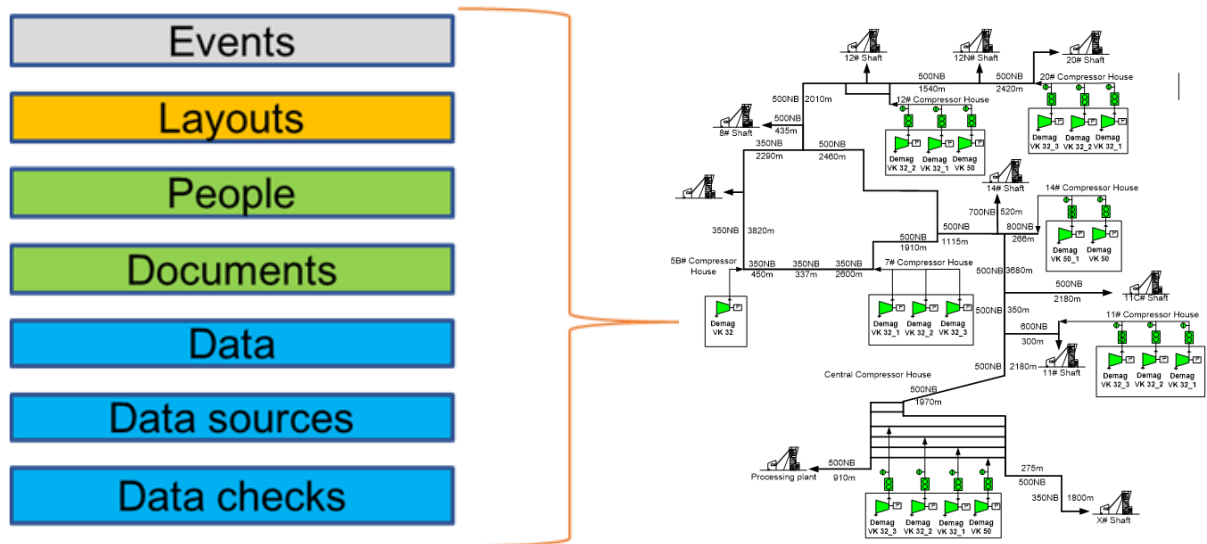



Figure 4: Energy reticulation information (Figure 21 shows the detailed version of Ring One’s layout)

The compressed air reticulation ring of a mine shown in Figure 4 is an example of a complex industrial process. The details of Figure 4 are not crucial at this point, as the focus must be on the required information. The reader may refer to Figure 21 for the full-sized layout of Ring One. The ring has 19 compressors () that supply compressed air to six active shafts as well as a processing plant. The interaction between the varying schedules of the consumers makes this a complex system. The information sources available must thus be utilised to understand how this site ought to be managed.

It is essential to understand the layout, available data and parameters, people supervising the ring and any events or documents that add insight into the efficient operation of the site. Figure 5 is a visual summary of the components required to understand energy reticulation.

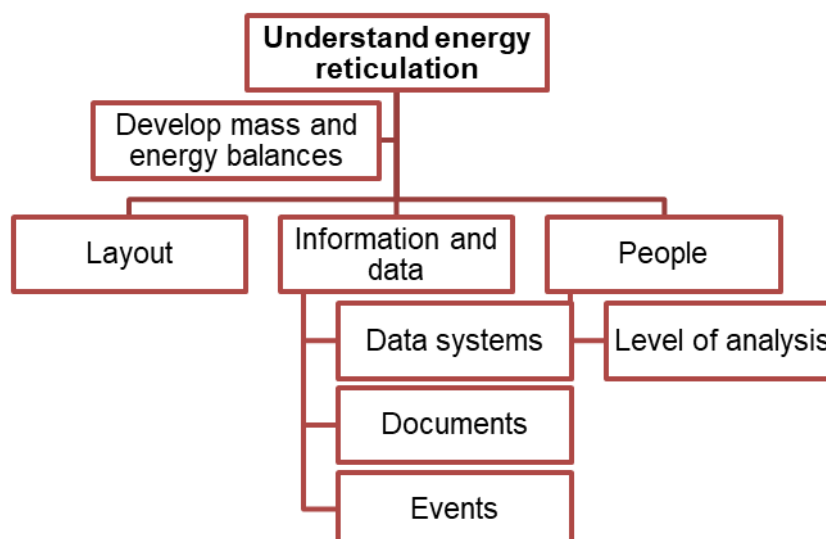

Figure 5: Understanding energy reticulation.

Mass and energy balances must be performed to understand the energy reticulation of an industrial site. Understanding the layout of the process contributes to a better understanding of how various energy streams flow through the site. Information and data also add insight into the quantification of the energy flowing through the site. The level of analysis required will be determined by the people involved in the energy management strategy.

LAYOUTS

Layouts are the first indication of how energy flows through the industrial site and therefore an essential indicator of how the production process works. High-level layouts can usually be found on SCADA systems or by collecting single-line electrical diagrams, depending on the energy carriers being analysed.

Understanding how measurement devices are used to analyse the site on the layouts can aid data traceability. Data traceability allows the energy manager to relate the data to the actual site. A data-based view is generated through identifiable data, which is captured by the measurement devices. This view is not necessarily wholly representative of the site but is an initial analytical interpretation of the process [23]. These measurements are only reliable and representative if the measurement devices have been calibrated [22].

Information and data

Continuous data loggers are ordinarily available and generate the data required to analyse the energy-governing factors. Due to the financial and pragmatic limitations, instrumentation is installed when the need to monitor an energy stream has been determined to be feasible. It

can be noted that a reduction in instrumentation costs has, however, led to an increase in the availability of data [24].

The vast number of data fields (columns in a table) makes finding the appropriate and relevant data a challenge [25] while keeping in mind that data must represent the energy reticulation accurately [4]. The correct measurement equipment accompanied by appropriate and relevant data must thus be used and referred to while analysing the site. The use of data requires that the energy manager understands where the data is generated, stored and used.

The technical process showing the flow of data is shown in Figure 6.

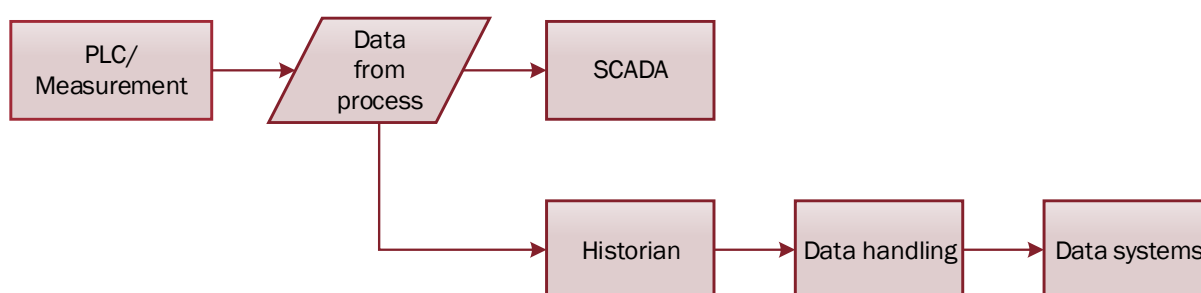

Figure 6: Data flow process

Raw data recorded by the process-variable sensors are sent to programmable logic controllers (PLCs). The PLCs convert the data into the desired unit of measurement. PLCs are programmed to measure a process variable and respond based on how that value compares to a set point. Data from the PLC can be sent to a central supervisory, control and data acquisition (SCADA) system to enable human supervisors to monitor and control the process [26]. Alternatively, data can be sent to the site historian for use in a data system. This data system, in turn, aids the energy management system as previously discussed.

Different data users have different needs for data handling and management due to the various requirements of different disciplines for the use of the data. Energy managers must therefore be aware of the potential of data manipulation to lead to data discrepancies. Subsequently, aggregation requirements can differ; for instance, an accountant must be aware of monthly financial movements, while a maintenance engineer must understand vibrations per minute.

Other factors that influence data are changes that occur in data sources and measurement instrumentation along with the process itself. These changes have to be managed and reflect in the data system. The knowledge of previous projects or events which influenced the process can significantly add to the understanding of both the process and measurement instrumentation.

Documents

Documents allow the energy manager to gain insight from information and knowledge already processed by the industrial site. For example, a list of energy-using equipment and the relevant specifications can give valuable insight into the process and its drivers [23].

Additional documents which can be used to give insight into the energy reticulation of a system include:

- Control philosophies
- Process description
- Standard procedures (operator manuals)
- Reports on previous projects
- News articles (historical information)

These documents help the energy manager to know how the process is understood, controlled and managed. Risks like safety, production loss and mismanagement are also identified. In addition to understanding how the industrial process is perceived and understood, the history of the process can be learnt and used to validate the data and understanding of the measurement instrumentation.

Events

Events give additional insight into the energy reticulation of a system. Events can also be used to validate the data. Information on the following aspects must be validated through data comparisons with these events:

- Projects
- Safety violations
- Upgrades
- Holidays
- Weekends
- Strikes

Events help the energy manager to understand, verify and validate movements observed in the energy reticulation view as generated from the data.

People

The personnel of an industrial process are valuable for understanding what drives the energy consumption of a process [23]. In addition to this understanding are various personnel, each with different roles in providing the assistance that the energy manager requires:

- Management must ensure that everyone is working together by aligning goals and schedules.
- Engineers give oversight to events and give technical insight into processes.
- Financial personnel are vital to ensuring that the energy managers are working feasibly and can be an essential source of information.
- Data owners provide access to and identify the relevant data.
- Control room attendants explain hourly trends.
- Operators explain the detailed behaviour of specific processes or process units.

Level of analysis

There are various levels of analysis to be gauged; these levels will be of different value to different people or users [27], as shown in Figure 7.

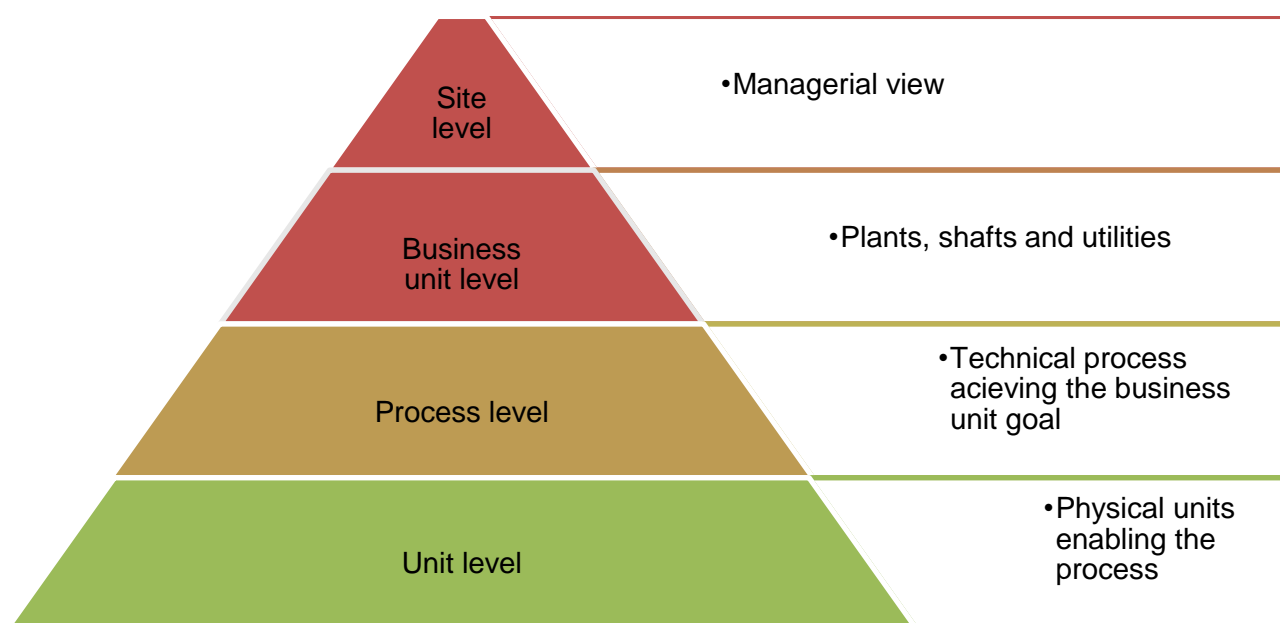

Figure 7: Levels of analysis

A site-level view would include the inputs and outputs of the industrial process. This simplified version of the detailed reality does not require a detailed view to make critical decisions, although a detailed understanding of the processes is still required to understand any energy movements ultimately.

This detailed view is captured in the secondary levels of analysis. An example of a subsidiary process is a business unit level view. This view typically includes plants, shafts and utilities. Utilities typically include the compressed air, refrigeration, electricity and steam supplied to business units across the industrial process. At the process level, specific goals required by the business unit is being achieved. At the unit level, a specific parameter or stream is being managed using this unit. A unit in this context could be a pump, compressor, heat exchanger, among other things.

Most of the data users are not interested in understanding all the available data, as they only require understanding their own required level of analysis. A few examples follow:

- Environmental engineers want to understand the effect of effluents on the surroundings. These effluents must be auditable at a site and plant-level view.
- Business unit managers require a plant-level view of the data.
- Energy managers or project engineers want to know how to optimise individual sections of a business unit. The influence of an energy-saving strategy must be observed at the site level to validate whether changes at the process unit level was significant.
- Technical personnel require more detailed views of the equipment for the data to be of use, but they require only the specific equipment information.

The appropriate levels of analysis must, therefore, be available to the relevant users.

Summary

The knowledge of how energy flows through an industrial process can be related to the measured data using mass and energy balances. Capturing the understanding of the process by structuring the data requires that various components of an energy reticulation analysis be consulted. The layout, data, documents, events, people and level of analysis contribute to the understanding of energy reticulation.

This knowledge has to be captured by structuring the data and making it accessible.

1.4 Knowledge capturing through data structuring

The understanding of energy reticulation can be classified as knowledge¹ if it can be verified by mass and energy balances which construe knowledge on the process and its size. This knowledge must be captured and related to the data system. It has been shown previously, whilst discussing the energy management background, that the data system is crucial to energy management. Information and communication technology (ICT) are therefore required to empower energy management [6].

ICT facilitates energy-efficiency improvements by allowing the data-user to track energy consumption in order to identify areas where savings can be made [28]. ICT is used to manage data by structuring it and making the information accessible.

ICT and standardisation play essential roles as enablers of energy-efficient process operations through access to data [6]. Improvements and upgraded implementations in ICT and ICT ecosystems greatly influence how data can be managed and present opportunities for improving data management [29]. These opportunities for improving data management are, in turn, also opportunities for improving energy management.

Despite the opportunities that modern ICT brings, it is not without its challenges. Communicating knowledge is a challenge because the knowledge tends to present itself in unstructured forms [29], [30]. The following knowledge-project factors expand on the characteristics of managing knowledge projects [30]:

1. The link between project outputs and economic performance or an industry value
2. The technical and organisational infrastructure
3. A standard, adjustable knowledge structure
4. Creating a knowledge-friendly culture is a challenge
5. Clear purpose and language
6. Change in motivational practices
7. Multiple channels for knowledge transfer
8. Senior management support.

These factors are analogous to the energy management scope's organisational and sustainability components. In addition to the energy management challenge of organisation and sustainability is the challenge of linking knowledge project outputs with economic

¹ <https://www.thefreedictionary.com/Knowledge>

performance (1). Knowledge projects show a low return on investment but create the necessary infrastructure for long-term data management solutions [25].

The technical and organisational infrastructure (2) required for energy management has been covered as part of the energy reticulation understanding. The adjustability component of the knowledge structure (3) refers to the ability to categorise information or knowledge in a way that is easy to configure. This configuration must ease access to the relevant knowledge, even when the motivation for industry practices (6) changes. This ease of access is what makes knowledge projects worthwhile to implement.

The transfer of energy reticulation knowledge is critical in energy management since communication is essential in this multidisciplinary environment. Communication improves both the required knowledge-friendly culture (4) and the required sustainability, but it requires unambiguous communication with a clear purpose and language (5). This simplifies the management of the multiple channels for knowledge transfer (7) and allows senior management to improve their support (8). The transfer of this knowledge is dependent on the data system.

Therefore, the data system must address more than merely the storing of data; data must be structured in such a way that multiple users can understand the origins of the data. The ideal solution must therefore allow the energy manager to structure the data towards their understanding of the energy reticulation. With this function of data management, the energy manager can share the energy reticulation knowledge and use the data to make data-driven decisions.

Spreadsheets are a common starting point for relating knowledge to the data. However, the use of spreadsheets results in multiple individual solutions across a facility and opens the possibility for knowledge to be lost within an organisation. Therefore, there is a need to centralise information without losing the speed and freedom of analysis that an intuitive spreadsheet program like Microsoft Excel offers. Consequently, an adjustable, straightforward system is required for managing data.

Given the need for creating a centralised knowledge management solution, a data system is required. Data management is becoming increasingly difficult due to the sheer amount of data that is generated. This need for a data system with the capability to manage large amounts of data fields results in the need for developers to build and manage database structures [18]. This does not, however, address the need from a knowledge management perspective. While

the energy manager has spent most of their time understanding the energy reticulation and the projects, they must be able to relate their knowledge to the data system.

It is crucial to improve the creation, protection and use of knowledge processes [30], [31]. Managing data systems with complicated industrial processes and many data fields typically requires data to be processed into simple, accessible forms. Unstructured data is data that has not been organised and understood in a way that is accessible to various users. The addition of required knowledge and relevant information to data results in structured data. For the energy manager's purposes, the data must be available in a database in which the data has been structured according to their energy reticulation knowledge.

Structuring data

Data structures refer to the internal design of a data system. The basic elements of a data structure, as utilised in this study, consists of data storage and identification. The identification of the data is created by relating information to the data. The current data structures used in energy management are rigid with limited access and flexibility mainly due to databases which are added to coded structures that result in a rigid structure from the user's perspective [18], [32], [33]. Rigid, coded structures create challenges for the energy manager using the system. There is hence a need for the use of simple interfaces for structuring data. The data environments already being used by the energy manager must be utilised.

An alternative method of analysis to spreadsheets and coded structures is the use of metadata. Metadata captures the information indirectly coded into the rigid structures or written into spreadsheets. Metadata is data added to data to provide the required context [34]. By adding context to tags, the measurement devices of the energy reticulation network can be individually identified and interpreted in accordance with the energy manager's knowledge. Structural metadata can be used to infer a dynamic structure. Therefore, the use of metadata creates adjustable data structures [18], [25].

Using words to manage data is possible with metadata repositories or tables [25]. Formalised metadata removes ambiguity to capture the knowledge without loss of information that results from interpretation [35]. Knowledge organisation systems can be used to define the metadata that has been used to relate the energy reticulation knowledge to a database [36].

A key component of knowledge organisation systems is classification schemes. The study of knowledge organisation and classification schemes can be used to formalise the metadata. To decide to what extent the metadata would be formalised, the energy manager's

requirements must be considered. Classification schemes like folksonomy, enumerative classification and facet analysis can provide guidelines to assist in creating a framework with which to capture energy reticulation knowledge.

Folksonomy uses natural language generated from common knowledge to define entities. Folksonomy is also known as collaborative tagging and allows the energy manager to capture the knowledge of domain experts [37], [38]. This scheme can, however, be ambiguous due to a lack of guidance for the end-users. This means that folksonomy does not sufficiently nor independently address the energy manager's requirements. Additionally, a repository with no structure is difficult to extract relevant knowledge from [30].

Enumerative classification schemes consist of predefined entities that are made available for the users of the scheme to classify the knowledge they are defining. All the categories must thus be defined beforehand. Examples of the enumerative classification schemes include the Dewey decimal system, where numeric codes classify books and the library of congress classification, which classifies more classes due to the alphanumeric system [39], [40].

While folksonomy can become ambiguous, enumerative classification schemes are formalised structures that can become rigid. Therefore, it is essential to understand what balance of prescription is required to meet the energy manager's needs.

Another school of thought in classification schemes is facet analysis. Facet analysis has been found to be an essential aspect of the modern management of large quantities of data fields [18]. Facet analysis is similar to enumerative classification schemes in the sense that terms are sorted into a predefined hierarchy. This hierarchy is then broken down into different facets as defined by the user [12]. The difference is that the structures do not necessarily have to be completely predefined; only the facets and hierarchy must be predefined. The result is that the freedom from folksonomy is achieved but with the required unambiguity of enumerative classification schemes.

Facet classification is traced from universal decimal classification (UDC), an adaptation of the Dewey decimal system [36]. It was created in response to frustrations that arose from the limited access to a continuously growing universe of knowledge. S.R. Ranganathan was the creator of facet analysis. He wrote the five laws of library science which express his frustrations [41] and which is similar to what is needed in data today, as shown in Table 1.

Table 1: The need for accessibility

Facet analysis – access to books	Access to data
Books are for use	Data must be used
Every reader must get his book	Every user must see relevant data
Every book must find its reader	All data must be used
A reader's time must be saved	A user's time must be saved
A library is a growing organism	An energy management system is a growing organism
Books are for use	Data must answer questions

Table 1 indicates that the need for accessibility of information has not changed, even though the information source has changed. The real power of facet classification is the adaptability that results from the use of computerised systems like databases [42]. The classification of subjects with words is a crucial concept of formalising scientific theories. Therefore, it is suitable that the rules of facet analysis provide the basis for creating a data structure through metadata [25], [31].

Table 2 summarises the main characteristics of the classification schemes discussed.

Table 2: Classification scheme summary

Characteristic	Facet analysis	Enumerative classification	Folksonomy
Structure	Predefined	Predefined	Defined by users
Classification	Defined by users	Predefined	Defined by users
Scalability	Yes, due to adaptability and interoperability	Lacks adaptability	Limited interoperability

Folksonomy is ideal for capturing the domain expert's knowledge in the system in an adaptable manner. However, folksonomy does not address the need for interoperability between metadata tables and other structures. Interoperability is the ability of a system to relate, use and exchange information. A formalised (predefined) set of semantics or classification thus allows computers to match information, thus resulting in interoperability. Although enumerative classification addresses the need for formalised semantics, it lacks adaptability. It is subsequently apparent that a mixture of folksonomy and enumerative classification must be employed. Facet analysis accommodates this compromise and would therefore inform the development of a metadata structure.

Summary

Energy reticulation knowledge must be captured and made accessible. ICT and standardisation are essential enablers of energy-efficient process operations through access to data. While rigid data structures are used, they limit access to relevant data. The alternative use of spreadsheets results in individual solutions with little value for the collective data users.

The use of metadata allows relevant data to be defined and managed in a centralised system. Classification schemes were consulted to ensure that enough formalisation and structure was given to the data system toward enabling the efficient use of metadata. Facet analysis must inform the design of the data system to empower access to the relevant data by relating energy reticulation knowledge to the data. This access to data will enable energy management.

1.5 Enabling energy management

The knowledge captured in a metadata structure was observed to aid access to data, which leads to improved energy management. Energy management is improved because decisions are supported through the accessibility of data. The energy management scope must be aided through the data-structuring framework that is developed. This means that the framework must inform the strategy, operation, control, organisation and sustainable development.

The strategy to be implemented can be informed by the understanding of energy reticulation. The metadata framework can evaluate this understanding by making the data accessible in the context of mass and energy balances. Changes and distributions must be observable to such an extent that the development of a strategy to manage the use of energy or risk would be based on the available data. Thus, through an iterative process, this framework must also increase the understanding and evaluation of the energy reticulation.

The data structure must then permit the implementation of the developed strategy. The relevant information that pertains to the energy reticulation and instrumentation layout must be observable, manageable and the data-structuring framework must generate a view where continuous energy audits can be monitored.

Managing the implemented strategy means that it must be controlled and adjusted when goals are not being achieved. Benchmarking and baselines must be available to understand how the current operation compares to the historical consumption of the system. The framework must thus permit the use of these energy management tools and permit the use of KPIs .

Procedures, responsibilities and job descriptions ought to also be updated from the lessons learnt from the control of the strategies, and the framework must improve communication between the relevant personnel by giving the correct information to the relevant personnel. The captured context will assist in organising the use of data in general.

Companies must foster a culture of energy management that is conducive of sustainable energy management. The data and reports generated by the framework must therefore aid in the education of the relevant site personnel and assist in the internal communication of the energy-saving message.

1.6 Need for the study

It has been concluded from literature that energy management is important to industrial production processes and the accompanying environmental efforts. In order to manage the energy streams flowing through a production process, the ISO 50001 standard requires that the data generated by industrial production processes needs to be managed.

This means that the available data has to be organised to allow the energy manager to make data-driven decisions, which will affect complex processes. The organisation of the data must incorporate the understanding and the auditability of the energy reticulation.

The need for data access has also been clearly determined, as this allows the understanding and knowledge linked to the data to be utilised by relevant users. Various levels of analysis are required; thus, the solution must consider the various users and the process of knowledge collection and organisation. The dynamic nature of the industry must also be considered. These findings in literature resulted in the following needs of the study:

Data management

Large numbers of data fields and information must be managed by making the relevant data accessible. The data system requires have an adjustable, simple structure that provides access to the relevant data. This need exists because current structures are so rigid that relevant data access or collaboration is limited. Time-based, numerical and categorical data must be managed and related to create a data structure. Data management, with this data structure, must therefore aid the analysis of energy-governing factors and assist with the energy management scope.

The need for an adjustable data structure

The dynamic nature of energy reticulation, owing to projects and changes in organisational requirements, results in the need for an adjustable data structure. Structural metadata creates an adjustable structure, but the formalised structure must be developed using the design principles from facet analysis. The energy manager, having spent most of their time understanding the energy reticulation and the running projects, must also be able to relate that knowledge to a data system on a continuous basis. The result will be a dynamic, insightful view of the energy reticulation network.

Enable energy management

The knowledgeable view of the energy reticulation network as supported by the data structure must be used for energy management strategies to be developed. Data-driven observations must be made to identify problems. These problems must then be managed by means of relevant questions which can be answered by accessing the relevant data. The solutions gauged by the energy manager must be developed into energy-saving strategies.

Energy-saving strategies must be implemented and monitored using the accessible data. This means that continuous energy audits must allow the control of these implemented strategies by enabling benchmarking techniques and reporting on the movements. The organisation of systems, structures and people will be promoted by data-driven communication, which will also add to the culture by improving the understanding of the personnel involved with the energy-saving strategies.

The data structure should also enable and promote a culture of sustainability. The knowledge captured in the process will lead to a sustainable environment despite personnel changes. Training must be made possible through the knowledge that has been captured in the data structure.

Problem statement

From the discussion of these needs and the background, the following problem statement has been developed:

Data must be structured to capture energy reticulation knowledge in such a way that the relevant data is accessible and enables energy management.

1.7 Objectives

In order to address the problem as developed from the need for the study, it is necessary to compile and organise the relevant information. This information can then be used to create an adjustable data-structuring framework. The resulting data structure must then be related to the data using ICT. This will provide data access through the levels of analysis as identified by the need of the study. The data access should then enable energy management. The scope and objectives are further discussed in this section.

Scope

The scope of this study includes energy management systems which allow the organisation to develop energy-saving strategies. Implementing these energy-strategies requires an understanding of the energy reticulation of the investigated processes. Energy audits must be used to provide an understanding of the process' energy consumption history. Mass and energy balances provide a framework with which to gauge certainty in the understanding of both the energy reticulation and energy audits. Data management is necessary because the mass and energy balances are based on process measurements, which generate data. Metadata and data structures allow the data to be defined in such a way that the required information can be accessed. Knowledge organisation defines how the metadata tables can be designed to best capture the required knowledge and access the information captured in the data system. The use of information communication technology (ICT) is required to facilitate the connection between the metadata tables and the data. Data-driven decision support will, in that event, be the result of accessible data, which in turn will drive energy management.

Capture energy reticulation knowledge

A dynamic understanding of the process must be captured in a data structure. Energy audits must be accessible at a high level of detail which aggregates from a less detailed view. Mass and energy balances must be used to aid energy audits. These balances would create a numerically accurate check for identifying any uncertainty of the energy reticulation understanding that was captured in the data structure.

Instrumentation knowledge must be captured in such a way that the data usage can be traced back to the original measurement device. Information from various sources like layouts, drawings, people, events and instrumentation information can be used to this end.

The domain expert should be in control of the data management process by their ability to manipulate the metadata structure. The structure must organise information pertaining to both the timeline and energy reticulation of the industrial process. All the relevant energy governing factors must be available and accessible.

Create adjustable data structures

The use of structural metadata helps in the setup of adjustable data structures, but these structures must be intuitive and easy to navigate, at least to the relevant personnel. This requires an understanding of the degree to which the solution must be formalised and the extent to which facet analysis can be used to manage metadata and assist in this formalisation. The framework must permit a centralised data system with which to remove unnecessary knowledge capturing solutions in an organisation.

Enable energy management

The benefits of structured data pertaining to energy management opportunities must be determined and be in line with the energy management scope – this means that the following points must be realised:

- Energy management strategies must be developed using the data structure
- The framework must promote the implementation and control of strategies
- The organisation and sustainability of projects must be advanced.

The implementation of an energy management strategy will effectively test and validate whether these objectives have been met.

1.8 Conclusion

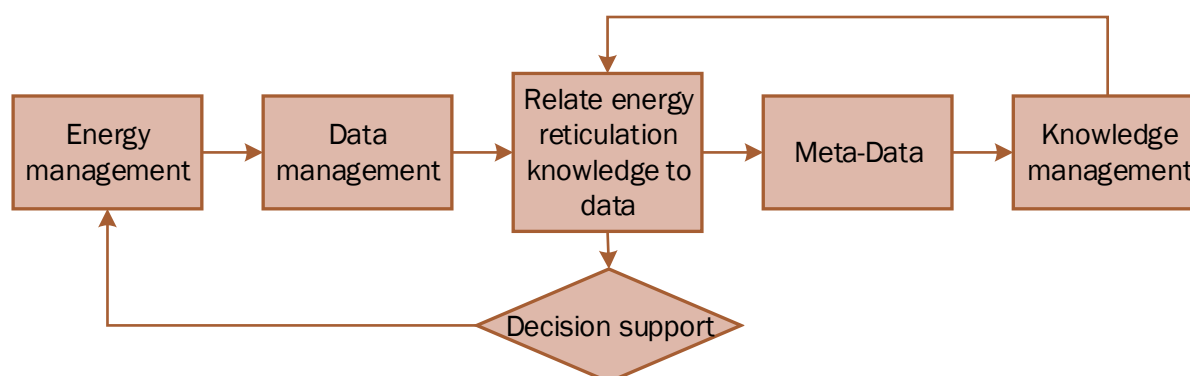

Figure 8: Summary

Figure 8 offers a visual summary of this chapter and indicates how knowledge management can result in improved energy management.

Energy management is a multidisciplinary challenge which is dependent on data management, which relies on the measurement of the process in question. The data is only useful once understood in terms of a process' energy reticulation measures.

Energy reticulation knowledge must be related to the data; however, managing these vast amounts of data is a challenge, not only of numerical computation but also of comprehending an extensive and complex system. Rigid data structures or multiple spreadsheets are currently used in energy management, but metadata allows for the creation of adjustable structures.

Improved data management is possible by creating an adjustable data structure that uses relevant and accessible data and relating knowledge to the data. The solution to be developed will focus on the management and formalisation of metadata with the assistance of facet analysis. The improved data accessibility results in data-driven decisions.

The need to manage energy through data management has led to the problem statement:

Data must be structured to capture energy reticulation knowledge in such a way that the relevant data is accessible and enables energy management.

Document structure

Chapter 1 has introduces energy management, its dependence on an understanding of energy reticulation and data management. Data management is a challenge due to the understanding that is required of many data fields in the context of the industrial process' energy reticulation.

The objective is to assist the energy manager in capturing energy reticulation knowledge dynamically to improve energy management by means of improved data access.

Chapter 2 develops a solution and discusses the data and information collection and organisation that depend on the requirements inherent to understanding the energy reticulation of a process. Next follows the implementation and development of a generic data-structuring framework. The developed framework will be used for energy management.

Chapter 3 applies the developed solution to an industry-based case study, and verification and validation are done using a mining case study. The resulting data structure is evaluated and discussed.

Chapter 4 concludes the study with a summary and recommendations for future studies.

CHAPTER 2: DEVELOPMENT OF SOLUTION

2.1 Introduction

Energy management is important because it has financial and environmental implications. In order to manage the energy of an industrial site, it is necessary to understand how energy flows through the site and quantify these movements. A vast amount of data (process measurements) is available, but access to relevant data is limited by the knowledge of the user. This access can be improved by relating energy reticulation knowledge to the data. This background has led to the following problem statement:

Data must be structured to capture energy reticulation knowledge in such a way that the relevant data is accessible and enables energy management.

In order to address the problem statement, as developed from the need for the study, the relevant information with regards to understanding the energy reticulation of a process must be compiled and organised. This information can be used to create an adjustable data-structuring framework. An adjustable data-structuring framework can be developed by using metadata to make data accessible. Metadata is additional data consisting of terms which describe the numeric data. The developed data structure will allow access to the relevant data. The data structure must be made interactive and dynamic through information technology to enable energy management.

The adjustable data structure will provide the data access through the levels of analysis, as identified by the need of the study. The adjustable data structuring framework can then be used to aid the energy manager in making relevant observations. These observations must result in actions which enable energy management.

2.2 Compile and organise information

Data must be structured to capture energy reticulation knowledge in such a way that the relevant data is accessible and enables energy management. Capturing energy reticulation knowledge, creating adjustable data structures and enabling energy management are the key objectives for developing a solution to the problem statement. The problem statement requires the capturing of energy reticulation knowledge, which is developed by collecting, processing and understanding information and data.

The information that makes up energy reticulation knowledge has to be compiled, organised, then related to the data through a data structure in order to enable energy management. As the previous chapter has shown, there is a need for this data structure to be adjustable, since adjustable structures make data more accessible by defining data in groups according to the developed understanding of the data.

Relevant information has to be collected to understand the energy reticulation of a site without wasting time. Understanding energy reticulation data, as described by the available information, will improve an energy audit. The continuous task of collecting information and data also implies frequently organising and managing the collection of said data. A guideline on the collection of relevant energy management information will therefore be proposed.

To determine whether data is relevant, it is essential to understand the industrial process and its driving factors. While vast amounts of data and information are available, knowing which data or information to consider simplifies and reduces the workload. The industrial process must be researched with a focus on the relevant energy-governing factors for the purpose of improved energy management.

Industrial methods used to convert raw materials into more valuable products must be understood in order to utilise the available data correctly. The processes must include the collection of process drawings, operational procedures, control philosophies, site-specific standards, safety and risk management strategies and information from previous projects. These documents can offer additional insight into the organisation's history and culture; however, the focus of the process research is on understanding the industrial process in the detail that is required to understand the process' energy consumption. Defining process boundaries will qualify an understanding of the industrial process in varying detail.

The required level of analysis is a determining factor when defining boundaries. A high-level analysis will result in the management of full-facility boundaries. Full-facility boundaries answer the question of what goes into the process and what was the bottom-line result. The

bottom-line result refers to the required cost to achieve the desired process goal, such as production – simply stated, it is the profit made. A more detailed analysis will result in the analysis of a process or specific unit. The required level of analysis will be determined by the project or the extent of responsibility as defined by the energy manager's contract.

The boundaries to be analysed are determined by the understanding of the process and the energy streams flowing through it. The defined boundaries must include a specific process, which means that a single process goal must result from the output streams of a boundary. These goals include converting specific raw materials into more valuable materials, moving material to more accessible locations, converting the material into energy or achieving any other goal required by the industrial process. To simplify the selection of boundaries, they must include recycle-streams.

The next stage is to understand the available and relevant data as generated by process measurements. Process measurements are usually taken to quantify the flow of various streams through a site. Understanding the boundaries will assist in the selection of the relevant data because the relevant streams will have been identified. Unmeasured streams of energy are unmanaged energy streams which deserve the attention of the energy manager, depending on the size and energy content of these streams. The methodology must be prioritised by the size and energy content of streams and process to ensure that significant energy consumers are managed. Energy streams must be noted and organised into a well-defined list.

After determining which boundaries and streams to analyse, the next step is to determine which parameters to analyse. Not all measured parameters will be of use from an energy management perspective. For example, pressure and flow are useful for the energy analysis of a compressed air system while temperatures could prove to be unnecessary information, mainly since the energy is quantified by means of the airflow and its relation to the energy used by the compressors. Pressure is a useful parameter in this case because it is indicative of the technical requirement of the consumers.

Once the appropriate boundaries, streams and parameters have been determined, the relevant data on energy-governing factors [17] can be compiled. Compiling the required data requires an understanding of how this data is used, stored and managed. To understand the data system, the SCADA, PLCs and historian (industrial site database) must be considered.

Understanding the SCADA system is necessary since this is the primary system which uses the data. Process and process-instrumentation drawings (layouts) can usually be found on a

SCADA system, as this is the system from where the process is controlled. Therefore, essential data is available from the SCADA system. SCADA data is, however, instantaneous data received from PLCs. The SCADA design is also the first indication of how energy is being managed, as this is where process control decisions are made. The KPIs available to the process operators should be scrutinised and improved from an energy manager's perspective.

The energy manager must know whether the required data from PLCs is captured in the historian. Historian data can be used to analyse what happened throughout the process history. The timeframe of data saved in the historian is limited to the availability of server space. The quality of the data saved in the historian will depend on the measurement devices used and the instrumentation calibration. It is the energy manager's responsibility to ensure that the data is an accurate representation of reality.

The collected historian data will include the essential facets of information, shown in Figure 9.



Date	Tags	Value
2017/12/31 23:30:00	S20CP03_PT_109_LOGIC_PV	538,59
2017/12/31 23:30:00	S20CP03_FNT_109_LOGIC_PV	24673,06
2017/12/31 23:30:00	S20CP01_FNT_109_LOGIC_PV	24673,06
2017/12/31 23:30:00	S20CP01_PT_109_LOGIC_PV	0
2017/12/31 23:30:00	S20CP02_FNT_109_LOGIC_PV	0

Figure 9: Data collection

The date/time field indicates when the datapoint has been measured, while the tags/fields field typically identify the measurement instrument. The values from the instruments then quantify the measurement point at the specific time identified. These values provide the foundation upon which the energy audit is to be performed; however, in its current unstructured form, the data is inaccessible to the typical data user. The breakdown of the energy reticulation knowledge, as boundaries, streams and parameters must be used to structure the data.

The understanding gained from the energy reticulation knowledge can now be used to create various energy balances and produce measurements throughout an industrial process. These balances can be used to structure the data from the unstructured form previously shown and to understand and verify the energy audit, as shown in Figure 10.

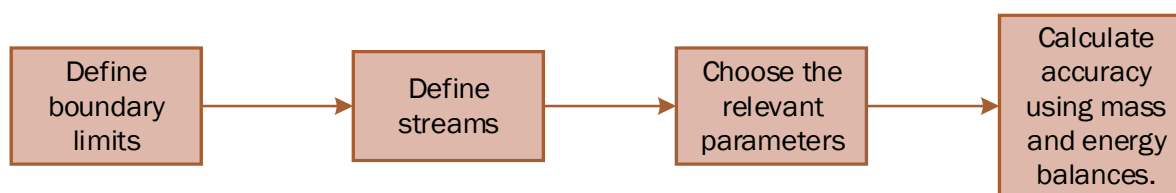

Figure 10: Mass and energy balances

It is necessary to define the process being analysed by first defining the streams that flow through a process to achieve its goal, which means that the various processes can be defined by boundaries. The relevant parameters to measure the required mass or energy must be determined for each stream to allow the required data to be selected. The mass and energy balances are built on the respective laws of conservation, which state that neither mass nor energy can be created or destroyed. The defined boundaries and streams can be used as references to define a flow convention. The most straightforward convention of flow through a boundary is, therefore, in or out of the boundary.

A flow convention must be simple yet incorporate interdependencies like recycle-streams while presenting the option to add an additional level of complexity to this convention. Recycle-streams are, however, not considered to be within the scope of this study for the sake of simplicity. Yet, this simplification must not hinder the process, as recycle-streams can mostly be avoided if the correct boundary conditions are considered.

The mass and energy balances, defined boundaries, streams and flow convention aid in the accounting of mass and energy and help energy managers record the energy reticulation. This accounting framework gauges the certainty with which these flows are quantified because the flow into a boundary must be equal to the flow out of a boundary. The accounting of mass and energy is further facilitated by the structured analysis and design technique (SADT) [15,43] method, which is illustrated in Figure 11.

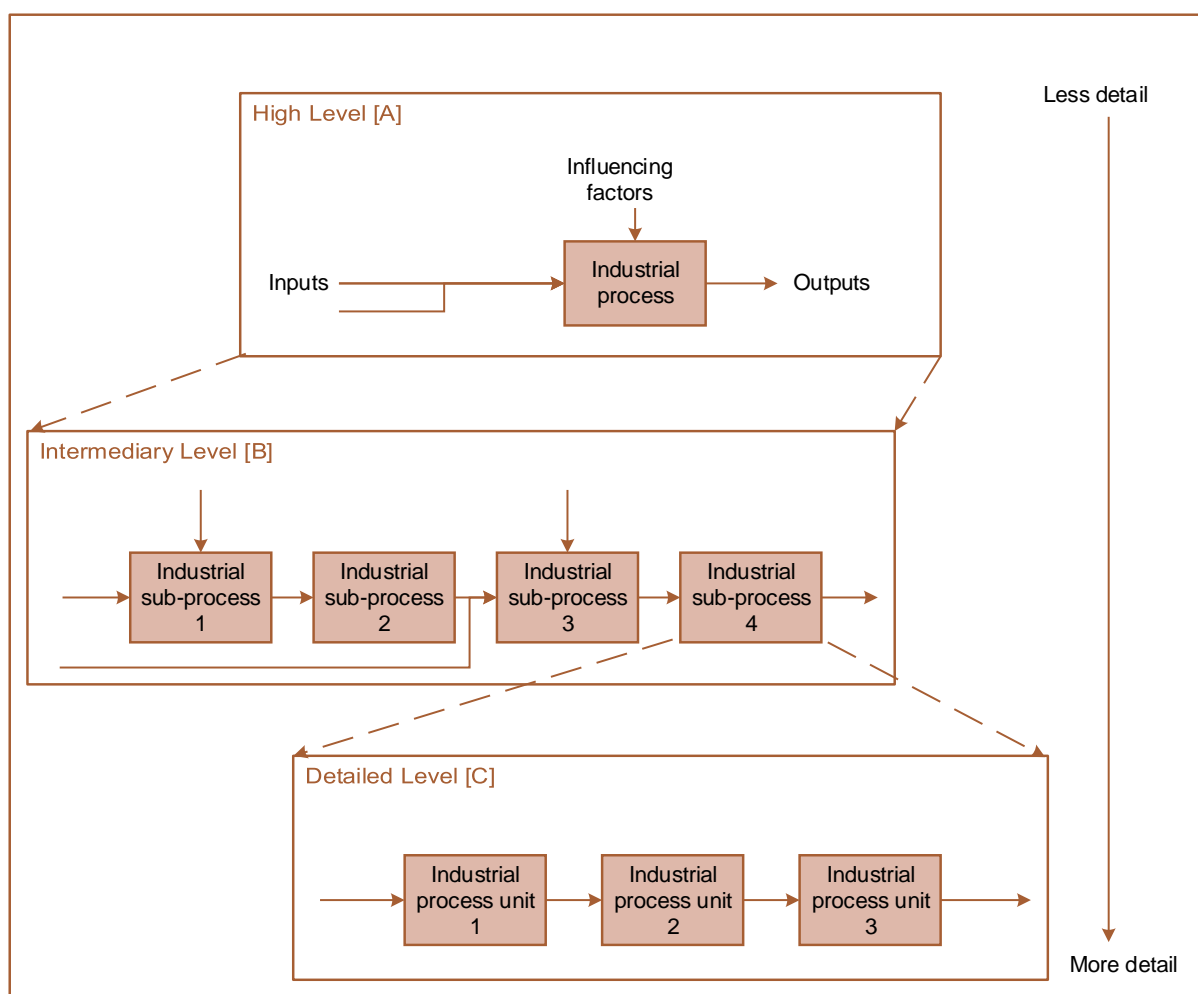

Figure 11: SADT method

The SADT method uses the defined boundaries and energy streams moving in or out of the boundaries. These boundaries are defined at a high level [A], intermediary level [B] and detailed level [C] but are only meant to be guidelines and can be expanded upon if necessary. Lower levels of analyses must summate to the higher levels and thus form a cascading hierarchy.

The balance between the supply and demand of the process can now be distributed between the boundaries and their respective levels of analysis. The SADT method, along with the data and information compilation guidelines, allows for data-driven data analysis [15].

Summary

Figure 12 visually summarises this section, which has presented a guideline to compile unstructured knowledge.

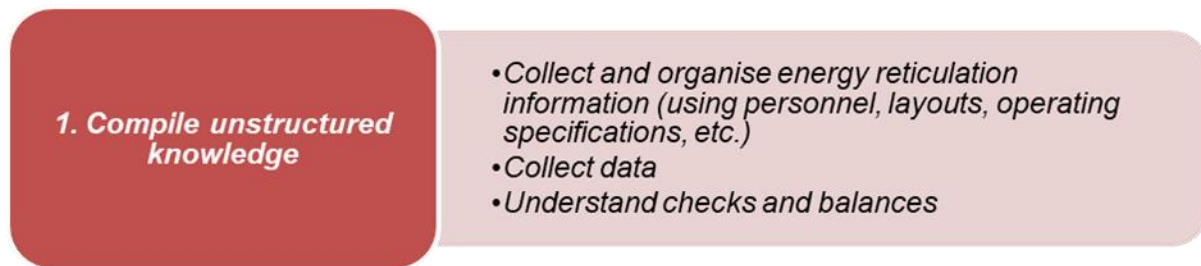

Figure 12: Compile unstructured knowledge summary

A guideline was presented for collecting and compiling relevant data and information so that the data could then be manually structured through the developed mass and energy accounting framework, which relies on the SADT method. Together with the accounting framework, the organised and managed energy reticulation information can result in the development of energy reticulation knowledge.

Next, energy reticulation knowledge must be related to the data in order to organise and structure the data with the objective of improving access to relevant data.

2.3 Create an adjustable data-structuring framework

The accounting framework that uses the SADT method together with energy and mass balances now has to be incorporated into a data structure to capture energy reticulation knowledge in an adjustable data structure. The compiled information must be structured into a metadata table to relate the compiled information to the unstructured data. The use of ICT permits the development of a system to ease access to the relevant data by relating the structured information to the unstructured data. However, energy reticulation knowledge must be structured before ICT can be employed.

Facet analysis is considered to structure the compiled information. To wholly structure the energy reticulation knowledge using facet analysis, five fundamental categories must be considered, namely time, space, matter, personality and basic subject [44]. The collected data from the historian contains the time, measurement device (meter) and value, which relate to time, space and matter, respectively. The compiled information adds to the personality and basic subject categories. The personality category relates to the parameter and the relevant unit of measure. The basic subject category relates to the boundaries, streams and flow balances. At this high level of categorisation, facet analysis does allow for the structuring of the energy reticulation information.

The six fundamental steps in design [36] for facet analysis explain how the information has to be structured:

1. Divide the subject into broad facets.
2. Divide each facet into specific sub-facets.
3. Decide on the citation order between facets and sub-facets.
4. Decide on the filing order between facets, sub-facets and classes.
5. Add a notation.
6. Add an A/Z index.

The hierarchy of these facets, sub-facets and classes are to be understood in order to initiate these steps. Facets (1) are categories which are the sum of the sub-facets (2). Facets are, therefore, divided into their respective sub-facets. Sub-facets are, in turn, the sum of the classes (3).

The six fundamental steps can be applied to structure energy reticulation knowledge into a metadata table. The facets of energy reticulation relevant to the data, as developed through the requirements determined by the compilation and organisation of information guidelines, include:

- A. Unstructured data.
- B. Compiled energy reticulation information.
- C. Data management.
- D. Time-based information like projects, tariffs and events.
- E. Additional notes and information.

These facets are the metadata tables into which the energy reticulation knowledge can be categorised and hence structured. Tables have fields (columns) and rows. It is therefore logical that sub-facets would be table fields while the row information would include classes.

The six fundamental steps in design require that a citation order (3) between facets and sub-facets be determined. The order in which these fields appear ought to correspond with the chronological process of information collection in order to simplify the process of populating these tables. ICT can be used to filter computerised tables and sorted them under the chosen digital environments intended for use. The use of ICT therefore reduces the need to focus on the order of filing classes into their fields (4).

The classes can now be defined by the user to ensure that the energy manager's energy reticulation knowledge is captured in the structure. The notation used to define classes must be understandable to the users (5). Classes must, however, be classified consistently throughout all the tables to ensure relatability. The filtering ICT capabilities of these tables help adhere to consistency requirements.

An index (6) is necessary in order to relate a facet to other tables. An index is a field which uniquely identifies every row in a table. The tag field from the energy reticulation information table must act as such an index. It is, however, good practice to uniquely identify each table with an index, should it be necessary to relate another table later.

It thus follows that the six fundamental steps in design can be used to guide the user in creating a table to capture the energy reticulation knowledge in an adjustable structure. The process of creating a data-structuring framework to capture energy reticulation knowledge will thus resemble the flowchart shown in Figure 13.

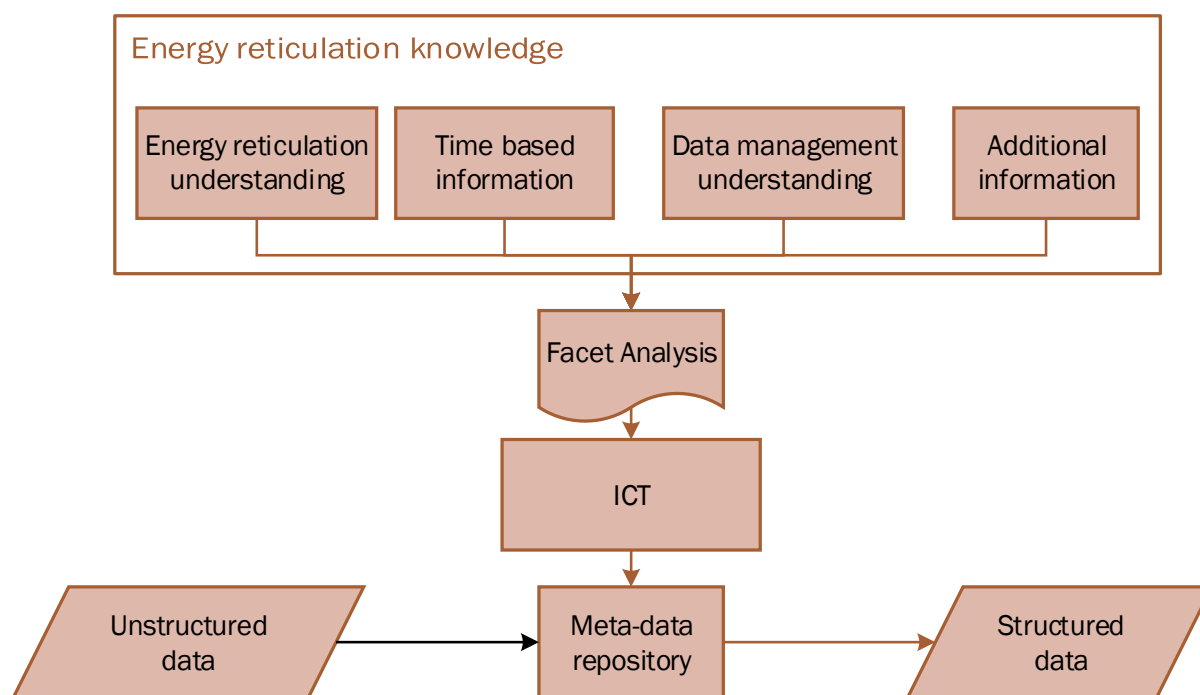

Figure 13: Metadata framework

The energy reticulation knowledge, thus consisting of the energy reticulation understanding, time-base information, data management understanding, and any other ad-hoc information, must be analysed using facet analyses. The use of ICT will permit the incorporation of facet analysis into a metadata repository, which, when related to unstructured data, is able to structure data. The facets identified from this analysis will then define the data through metadata tables.

The information in these metadata tables therefore captures the energy reticulation knowledge as it relates to the data. The design principles from facet analysis will dictate how these tables will be organised. The six fundamental steps in design and the coverage of the five fundamental facets ensure that the energy-reticulation knowledge is captured in the repository. The use of ICT influences the repository design, as is the case with the use of computerised tables. The data is therefore structured by relating the unstructured data to the metadata repository.

By using facet analysis, the tables can be further defined under sub-facets or fields. Possible fields for the energy reticulation knowledge tables are shown in Figure 14.

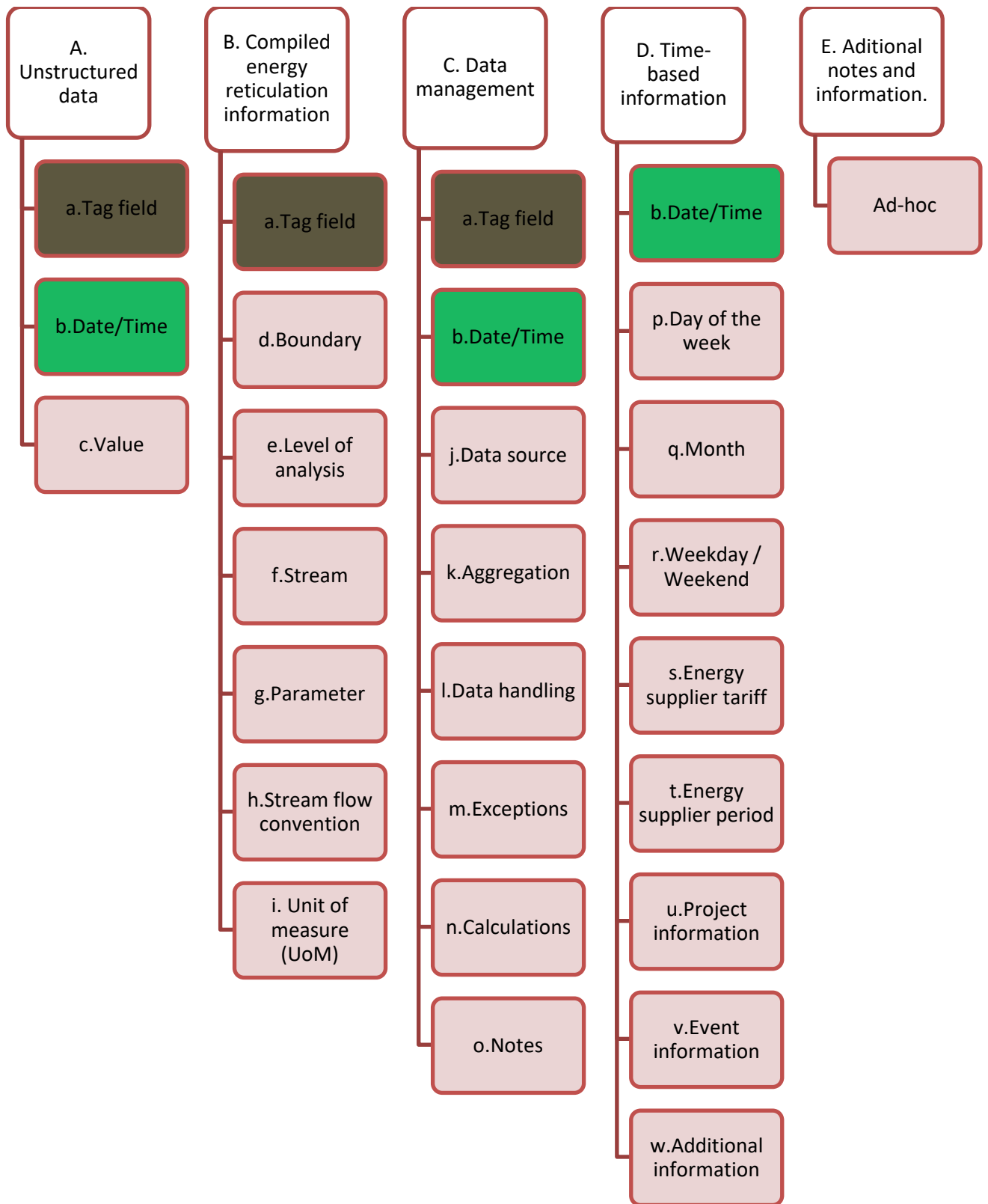

Figure 14: Energy reticulation knowledge

The metadata tables into which the energy reticulation knowledge can be categorised and therefore structured are shown at the top of Figure 14. The fields which make up the unstructured data table have been described in the previous section (2.1). The unstructured

data table contains the crucial measurements which can be related to the time and place they were taken. It must be noted that the tags and date-time fields are relatable to other tables.

To use the SADT method, the measurement device itself must be uniquely defined through the tag field (a). The tag field can be related to the unstructured data field because this is where the information expands on the data. The boundaries (d) must be defined together with their level of analysis (e). Process units are included in the level of analysis. Next, the streams (f) flowing through each boundary must be added together with all the parameters (g) that were measured. The direction of the measured streams must be indicated by the stream-flow convention (h). The unit of measure (i) must be defined to keep the actual values of the measurements intact. By defining these fields in a table, the accounting of mass and energy can be structured into a metadata table.

Information about data management (C), such as suspicious measurements, must be structured into a table. The proposed fields allow data handling steps (l) to be captured, calculations (n) to be recorded, data exceptions (m) to be logged and general data management notes (o) to be added. The data source (c) and aggregation (d) fields can be used to differentiate between data sources and data resolutions. Using the tag field (a) means that the information can be related to the unstructured data table while the date-time field (b) can be used to relate the information to time-based information, such as a calendar.

Time-based information (D) should be added and related to the time component of the unstructured data. The date-time (b) field proposed must relate to the unstructured data. To make the data accessible through such a structure, weekdays (p) and months (q) must also be related to the data. This way it will be possible to access specific periods. It must also be possible to differentiate between weekdays and weekends (r). Additional time-based information can also be added (w) if needed, including project (u) and event (v) information.

Financial information might depend on specific periods where, for example, an energy supplier's tariffs might differ throughout the day, week and seasons of the year. Such periods (t) and tariffs (s) can also be captured in this table by adding the required information to the time-based table.

Any additional information or ad-hoc analysis not covered by these tables can also be added by creating a new table (E), which relates to another table's index as required.

The metadata tables that have been created at this stage are now suitable and relatable to the data. These tables must, however, be in a form that allows for the most effective processing of the data. The processing of data includes aggregation, filtering, calculations and

visualisation. Tables are simplified using database normalisation theory, which will ensure that these tables are in their most useful form [45]. The use of ICT will thus be optimised by ensuring that the tables are designed based on normalisation theory. Then the tables are ready to be related and used.

At this point it is necessary to select an ICT tool to manage, relate and visualise the data and information. The use of these tools can, however, influence the application of the metadata framework. An example of this is the difference between SQL and No-SQL. SQL uses joins, merges and filters of tables to create relationships. No-SQL uses metadata related to tags/fields and creates connections using logic/algorithms. This reduces the need to normalise and simplify tables. Even though the modular approach used in this study has a philosophical basis, no-SQL tools are deemed to be outside the scope of this study. Relational databases [15], graph databases [46] and ontologies [47] are similarly not included in the scope of the study but can be used to add value to this methodology.

The use of related tables will be permitted with the Microsoft Power Suite^{3,5,8}. This allows the data to be extracted and loaded into the Microsoft data model². The tables can then be related by creating the required connections. Now the data and information in the data model can be pivoted and filtered as with a regular pivot table³. The result is that a centralised solution can be created without losing the intuitive environment of a Microsoft Excel spreadsheet.

There is, however, a learning curve which ought to be considered when adopting these tools. It is recommended that Data Analysis Expressions (DAX) should be learnt, as it is useful for models and calculations⁴, although there are limitations with data visualisation when using Power Pivot in Microsoft Excel. These limitations have, however, been rectified by Microsoft through Power BI⁵, which allows the same data model to be used to create a broader range of visualisations and models while serving as an additional visualisation tool which is not crucial to this study.

After selecting the appropriate tool, the data and metadata must be loaded into the tool. The data and metadata must be extracted from the Excel tables, transformed and loaded into the data model. The result is shown in Figure 15.

² Microsoft, Create a Data Model in Excel, (accessed 2019/09/30): <https://support.office.com/en-us/article/create-a-data-model-in-excel-87e7a54c-87dc-488e-9410-5c75dbcb0f7b>.

³ Microsoft, Power Pivot: Powerful data analysis and data modeling in Excel, (accessed 2019/09/30): <https://support.office.com/en-us/article/power-pivot-powerful-data-analysis-and-data-modeling-in-excel-a9c2c6e2-cc49-4976-a7d7-40896795d045>

⁴ Microsoft, Data Analysis Expressions (DAX) Reference, (accessed 2019/09/30): <https://docs.microsoft.com/en-us/dax/data-analysis-expressions-dax-reference>

⁵ Microsoft, Business intelligence like never before, (accessed 2019/09/30): <https://powerbi.microsoft.com/en-us/>

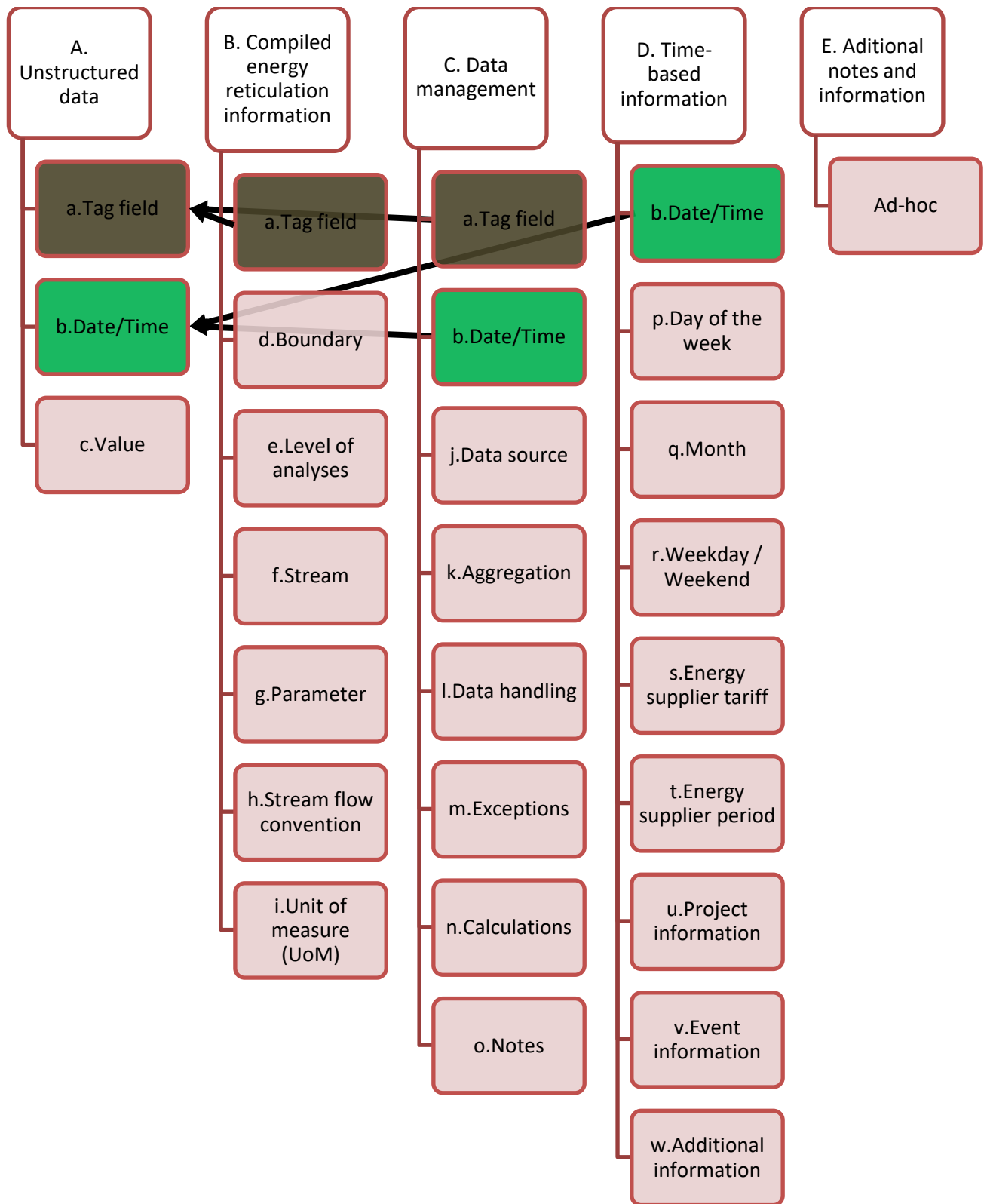

Figure 15: General data model layout

Fields which contain the same information can be related because these fields can be filtered simultaneously. The date-time (b) field from both the data management (C) and time-based information tables can be used to filter the data table date-time values. Similarly, the tag field

(a) from the compiled energy reticulation information (B) and the data management (C) tables can be used to filter the tags in the data table. The energy reticulation knowledge has now been related to the data and is part of the data model. The metadata tables are related to the unstructured data because this is how the data will be filtered. The relevant data can be made accessible by filtering through these related metadata. From this point, the data model can be used to create the visualisations which result in energy management observations.

Summary

Figure 16 visually summarises this section, which showed how to implement a data-structuring framework to capture energy reticulation knowledge.

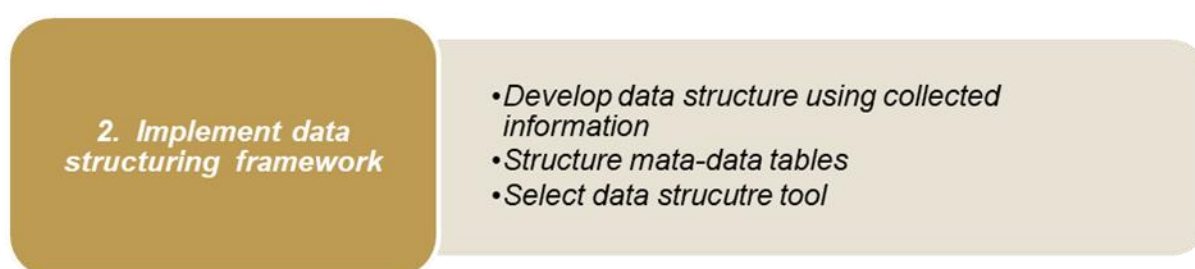

Figure 16: Data-structuring framework summary

Metadata tables were used to structure and relate the collected information and understanding of the energy reticulation to the unstructured data. A standardised structure was created by utilising knowledge organisation literature and resulted in an adjustable data structure, which the energy manager can create. The tables can be related to each other using an ICT tool.

Next, the structured data must allow enough access to relevant data to enable energy management. Observations made must result in actions.

2.4 Enable energy management

The developed data structure can now be used to filter and aggregate the data with the Microsoft PowerPivot Data Model and pivot tables^{2,3,9}. This creates dynamic views of the data through slicers. A slicer is a set of buttons that allows the user to choose a value from a field to filter data. The slicer therefore visualises the available options as the structured data model gives the user access to the data in the background.

Selecting different boundaries, streams, parameters, periods and levels of analysis will aggregate the data to the desired views. Movements can be observed by looking through defined boundaries, the levels of analyses and periods. The data can now be validated by matching trends observed with actual events in the process. The data observations will facilitate the understanding that energy reticulation is related to the actual process and events. Benchmarks can be used by overlaying different periods on the same graph, which will allow the energy manager to assess the progress of implemented energy-saving measures.

The energy reticulation knowledge, being structured and visualised, will empower the energy manager to perform their roles with data-driven decisions. The energy manager can report and share information to improve the understanding of the energy usage of the process. Figure 17 offers a simplified view of the effects that the captured information can have on the energy-saving strategies.

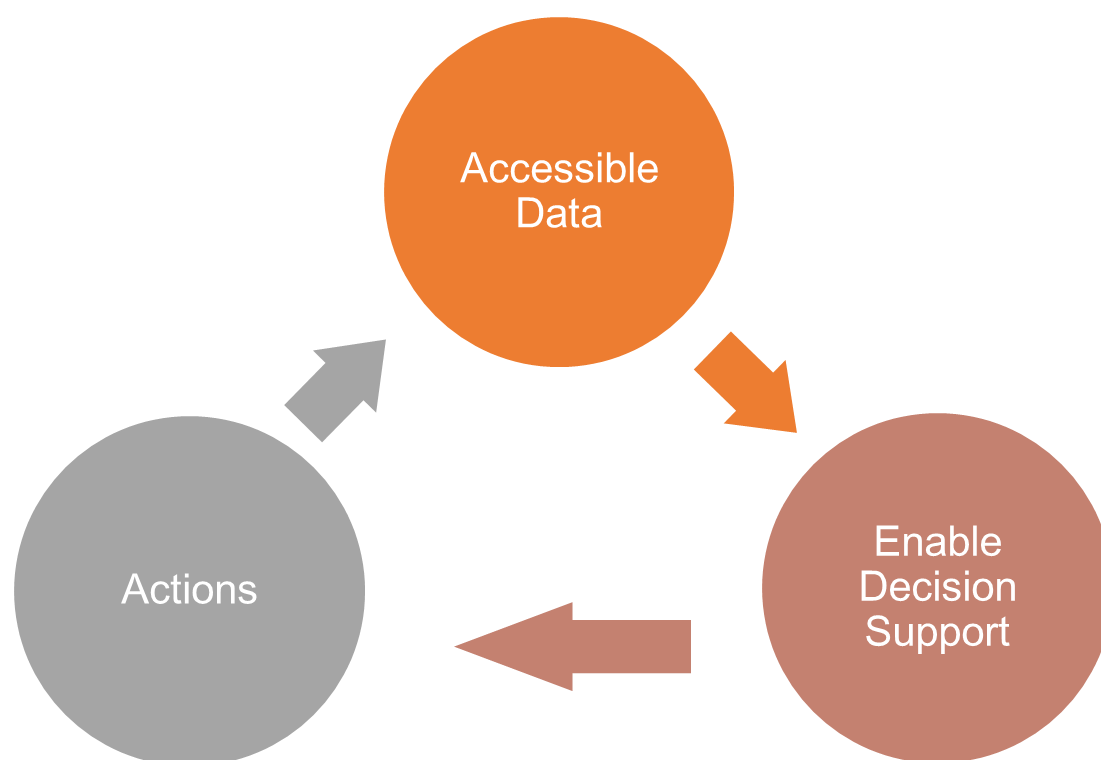

Figure 17: Observe and perform actions

Figure 17 shows how the related data and metadata can now be used to assist in the management of energy. Accessible data empowers the energy manager to make relevant observations, which, in turn, result in data-driven decisions. Energy management actions are therefore qualified by the data-driven decision support which the data structure provides.

Actions which result from these observations include the development, implementation and observation of energy-saving strategies. Control of the strategy is permitted by continuous observations which allow the energy manager to determine how the current situation compares to the benchmarked reference point.

In addition to the enabling energy savings strategies, the organisation of the energy management related systems, people, processes or documents is captured in the data structure. A sustainable culture develops through data-driven communication, which addresses any misconceptions that might be active in the operations of an industrial site.

Summary

Figure 18 presents a visual summary of this section, which expanded on how the developed data structure enables energy management.

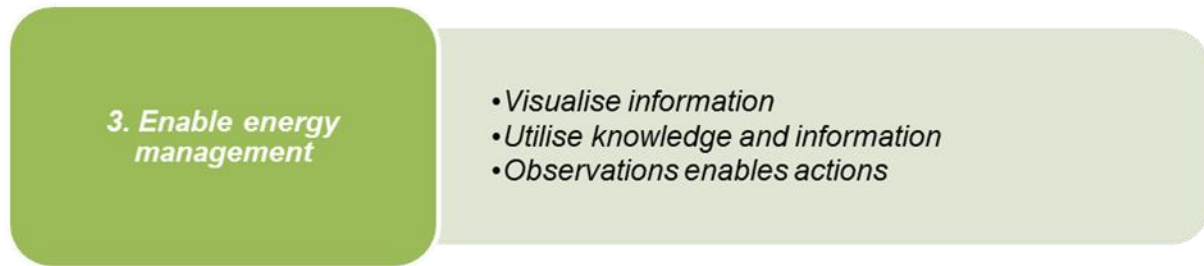

Figure 18: Enabling energy management summary

The developed data structure has captured the relevant information and data in an adjustable data-structuring framework. Data accessibility has thus been achieved, but in order to enable energy management, relevant data must be visualised. The observations must then be used to perform actions, which, in turn, enable energy management.

2.5 Conclusion

The visual summaries of the sections are presented together in summary of the methodology. The result is shown in Figure 19, which demonstrates how data is to be structured and how to capture energy reticulation knowledge in such a way that the relevant data is accessible and enables energy management.

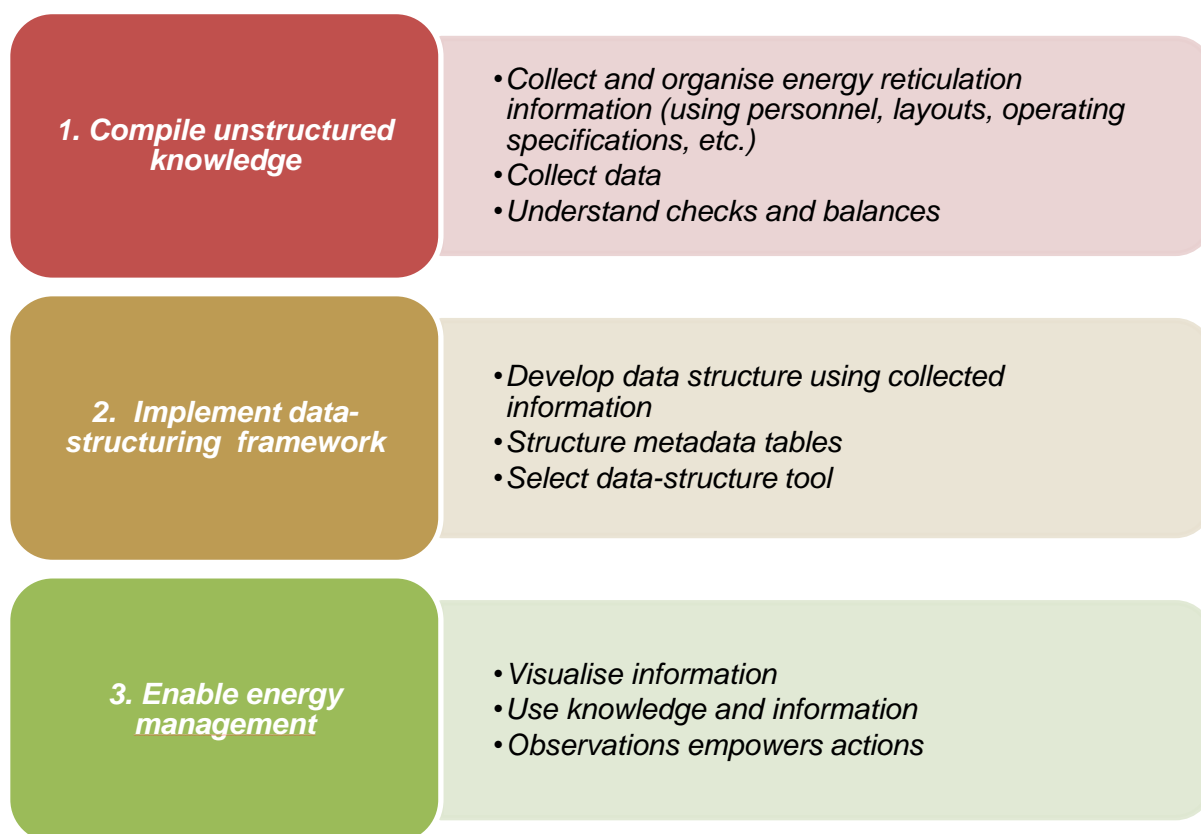

Figure 19: Methodology summary

A guideline was presented to collect and compile relevant data and information. Metadata tables have been used to structure and relate the collected information and understanding of the energy reticulation to the unstructured data. The resulting data model can be used to visualise the information.

The improved data access can be used to make observations which leads to actions. This means that energy management must be enabled.

CHAPTER 3: VERIFICATION AND VALIDATION

3.1 Introduction

The data-structuring framework was used to aid energy managers with the energy management scope. This framework enabled access to relevant data. Visualising the relevant data leads to energy management observations which must result in action. These actions will enable energy management.

A mining case study was used to verify and validate the data structure's ability to enable energy management. The data structure was built for a complicated compressed air ring.

It should be determined whether continuously defining and organising data improves access to relevant energy management data. It will have to be determined whether the relevant energy reticulation could be compiled using the guidelines given in the methodology. The various levels of analysis should be incorporated, while the data structure is adjustable in this regard.

Energy management has to be enabled by improved access to relevant data. Observations must lead to actions which improve energy management.

3.2 Compiled energy reticulation knowledge

The methodology developed in Chapter 2 has been applied to a case study from the mining industry. The case study focused on platinum Mine A, where a project with no capital expenditure was required to reduce its electrical consumption without impacting production. The developed solution was applied to organise and assess the opportunities and assist the energy managers in saving on energy consumption. The knowledge generated by the project was captured using the data-structuring framework.

The first step was to collect the relevant information and data to understand the processes. This initial step included consulting the engineering manager and the senior instrumentation technician. Access to the SCADA and the site historian was granted. The collected data was unstructured because the collected tags only indicated which meter generated the data. The data structure from the developed solution in Chapter 2 has assisted with the development of an energy management strategy. The knowledge and understanding of the energy reticulation of the relevant process were obtained by discussing the site process with the site personnel mentioned. The control room supervisors were consulted in order to understand the current control philosophies. In addition to the SCADA drawings, simplified layouts were available to add to the understanding of the site.

Electricity consumption data was obtained from the financial accounts (as received from the accountants) for Mine A. The data included the consumption for compressed air, mining, refrigeration and ventilation systems. The distribution of electricity consumption between the most extensive electricity consuming systems is illustrated in Figure 20.

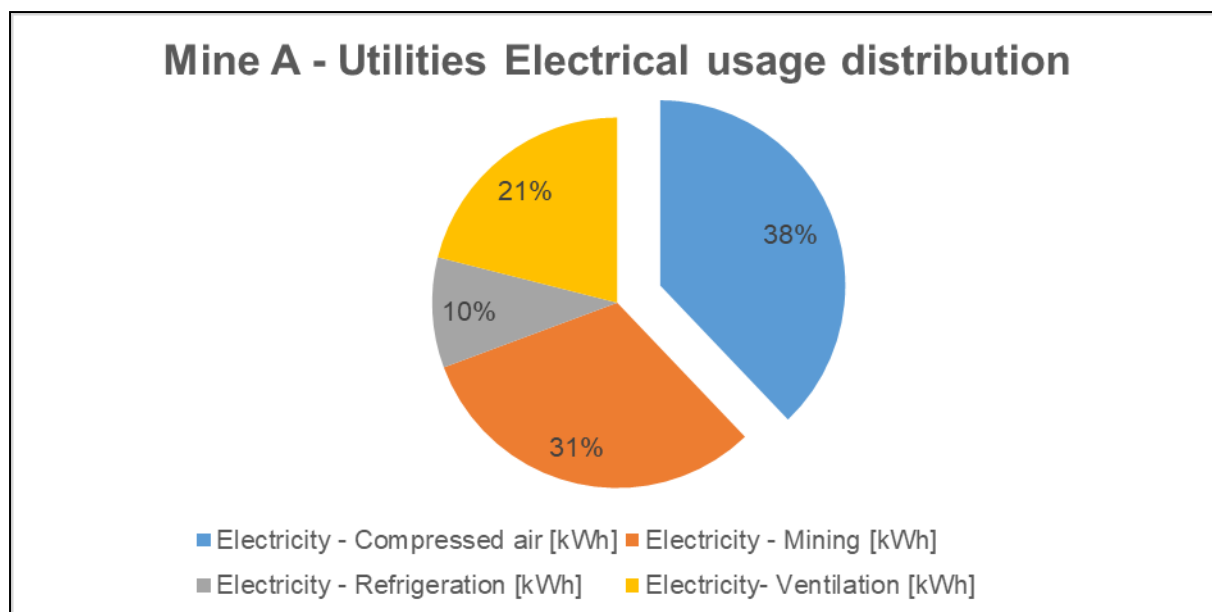

Figure 20: Mine A – High-level: electrical distribution

The distribution of Mine A's electricity consumption of the four significant consumers, namely compressed air generation, mining, ventilation and refrigeration, indicates that compressed air is a major consumer of electrical energy on the site. This knowledge can be used to understand the high-level boundary of the site. Understanding which major consumers to focus on permits the energy managers to focus their efforts on the most energy-significant systems. This knowledge focuses the initial implementation of the methodology.

The high-level electrical distribution shows that it is worthwhile to focus the initial efforts on the compressed air reticulation of Mine A because of the high distribution of electrical energy being consumed by the compressors [48]. The mining consumers are the second-largest consumer but include various consumers, such as cage-winders and water pumps. The result is that energy managers must focus on various smaller consumers. The third-largest consumer is ventilation, which uses electricity to power fans to assist with the ventilation of shafts. The smallest of the major electricity consumers is refrigeration, which cools water in order to address the high underground temperatures of the mine [49], [50].

The initial focus is, therefore, on the compressed air system. Mine A uses two compressed air rings to supply compressed air to their shafts and process plant. The shafts use the compressed air to drill into the reef in order to excavate platinum ore from the Merensky and UG2 reefs in South Africa [51]. The two rings are shown in Figure 21 and Figure 22, respectively.

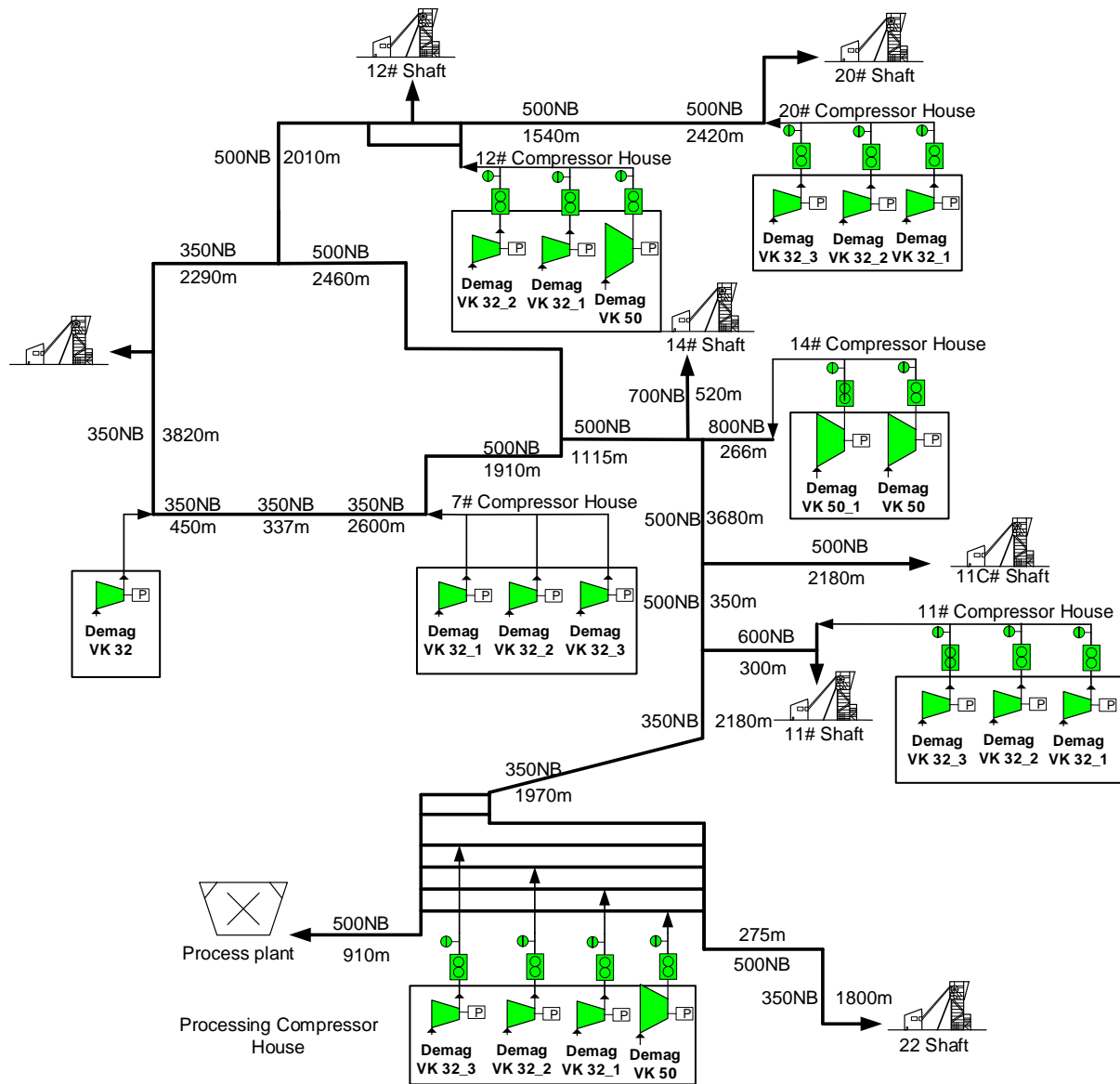









Figure 21: Ring One layout

The shafts are indicated with a shaft icon () and the processing plant is shown with a mill icon (), while the compressors are highlighted in green (). The bigger compressors are shown with a more prominent, taller icon (). The layout is merely a schematic representation of the process and is not drawn to scale. Flow (), pressure () and power () meters are also indicated on the drawing. The figure used for Ring Two is similar.

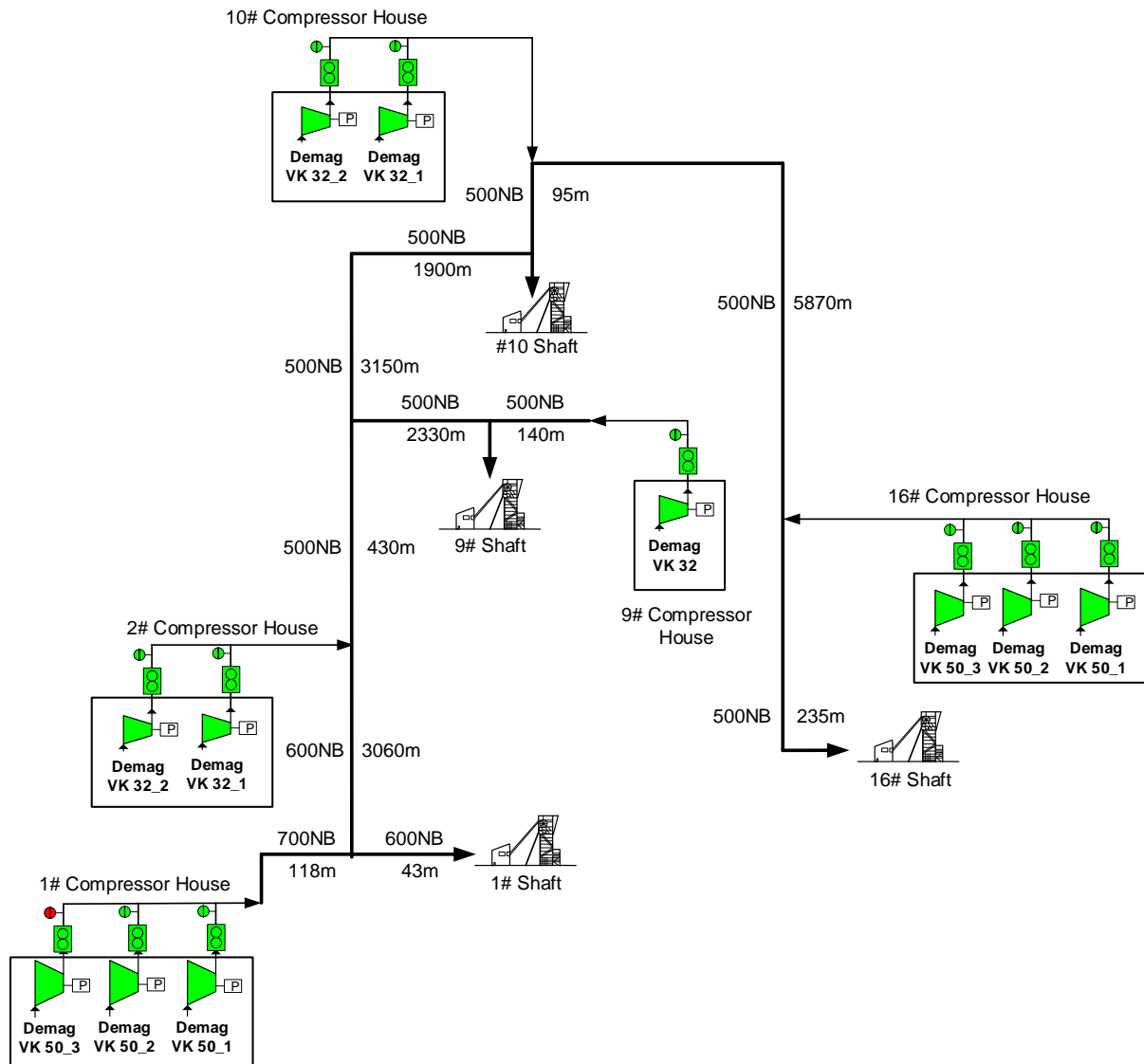

Figure 22: Ring Two layout

Ring One uses four 5-MW () and fifteen 3-MW () compressors while Ring Two uses five 5-MW and six 3-MW compressors. Ring One supplies the processing plant (), and seven active shafts (), while Ring Two supplies four active shafts. The combined surface pipes of these rings include 56 km of pipe. These compressed air rings are part of a complex industrial mining process which includes the excavation and refining of platinum group metals.

The complexity is not limited to the interactions between the various mining processes. The compressor houses and the compressed air consumers on the rings interact through supply and demand. These interactions create challenging control scenarios throughout the day. The driving factors of the compressed air process is the pressure supplied to the various consumers. The air consumption of the consumers and the compressor's air supply capability

determine what pressure is delivered to the shafts and processing plant from the ring. The compressed air demand varies during the day due to the workers' shifts, the equipment being utilised and the status of the various valves. The critical performance parameter to control is thus the pressure supplied to the shafts.

The shaft's pressure can be controlled by stopping or starting compressors. In addition to choosing which compressors to run, the pressures can also be altered by setting compressor supply pressure set-points. The supply set-points would adjust the compressor guide vanes to adjust the flow. In addition to adding control flexibility to the control philosophy, the use of the supply pressure set-points would affect the power consumption of the compressor when applied. The use of supply pressure set-points was, however, not in the operating procedure. The shaft pressures and demands were available on the SCADA together with the compressor anti-surge valve status guide vane angles and running status [52].

The SCADA was used to control the ring shows a layout of the compressors. The layout indicates which compressors were running, whether the anti-surge valves were open and what the live flows and pressures are. The layout was drawn over a satellite image of the site. A photo of the SCADA is shown in Figure 23.

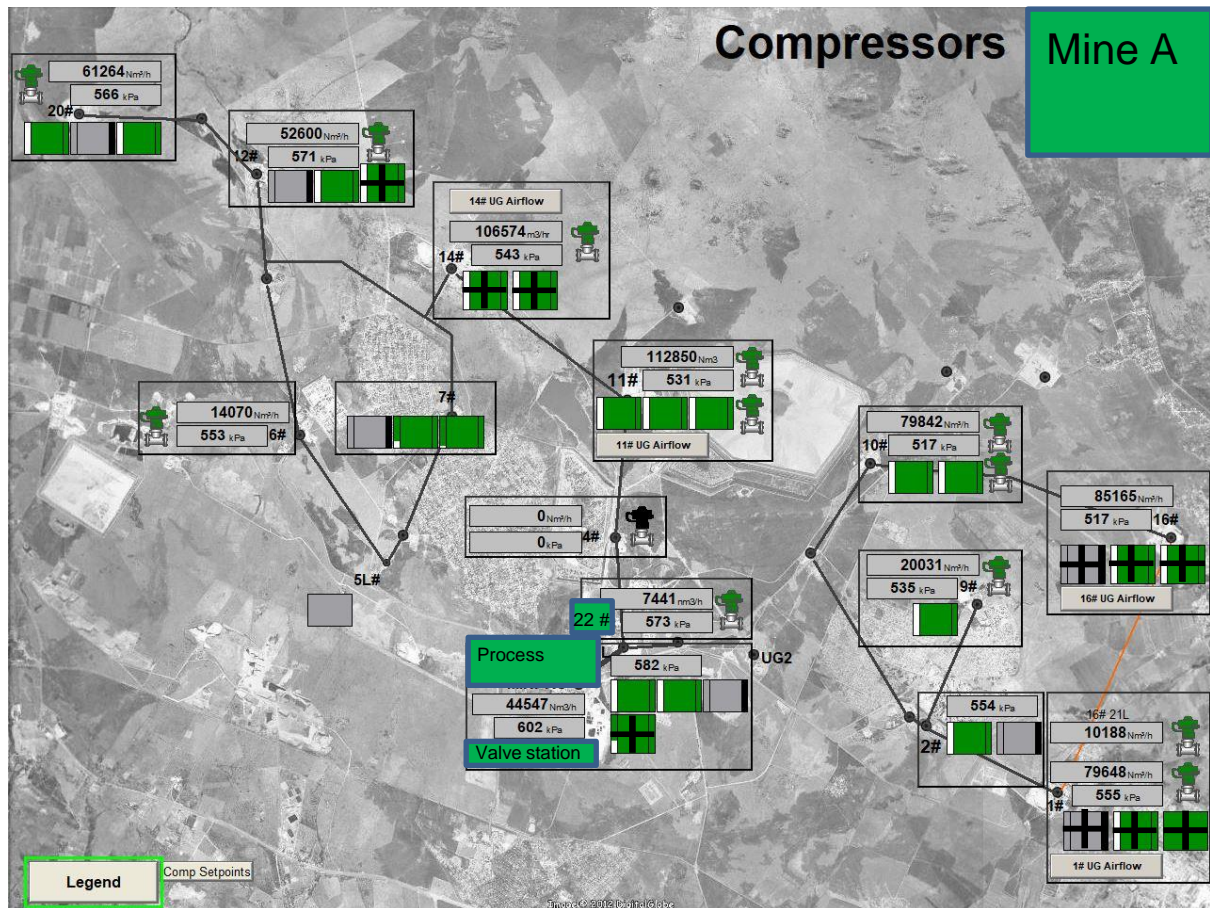

Figure 23: SCADA of MINE A

Each green/grey block (■) shown above represents a compressor. The blocks with the crosses (■) are 5-MW compressors, while the other green/grey blocks are 3-MW compressors. The white bar on the left of the compressor blocks indicates whether the guide vanes are open or cutting back. The black bars on the right of the compressor blocks indicate whether the anti-surge protection valves are in the open position. Green compressor-blocks indicate that the compressors are running, while grey blocks indicate that the compressors are switched off. Each dot (●) shown on the pipeline indicates a shaft. The SCADA empowers supervisors to manage and control the compressed air network by accessing the controls of the compressors. Control operating procedures provide a framework to guide the operators.

Documentation on old projects, control procedures, safety standards and project information were collected to gain insight on the process. The control philosophy indicated general pressure guidelines for the control room supervisors. Compressor start-stop procedures gave insight on some of the technical limitations, such as stop-start timing safeguards programmed into the SCADA. Efficiency testing methods accepted by Platinum Mine A stated that the compressors must run at 10 Nm³/kWh. The control room supervisors' time schedules were also obtained to gauge the various supervisor's understanding and mannerisms.

Additional documents such as detailed maintenance philosophies, lock-out procedures, safety considerations, risk assessments and condition monitoring analysis procedures were also found. Events and projects were researched with regards to the compressed air network. It was found that demand-side management projects have previously been active on the network. The use of control valves on the compressed air lines to some of the shafts were another example of previous projects. These control valves had a significant influence on the current control of the system.

The level of analysis would initially only be at surface level, but this would expand to the underground networks of compressed air pipes in the shafts. The level of analysis is initially at surface level to prioritise the implementation of the developed solution towards the significant energy consumers. The high-level process boundaries included the two rings, the compressor houses, shafts, and the processing plant. The goal of the compressors is to convert electrical energy and air into compressed air. The goal of the shafts and processing plant would be to use the compressed air as an energy carrier and the goal of the rings to convert electrical energy into compressed air as an appropriate energy carrier for the various consumers to achieve their goals. An example of such a goal would be to drill holes underground with rock-drills.

The boundaries, streams and parameters that are required to manage the energy were identified. The SADT method will be used to analyse and organise this information in the section that follows. To implement this method, a simplification of recycle-streams is required, but no recycle-streams were noted. Two ring feeds were found between shafts. Even though these ring feeds increased pressure at specific crucial underground points of the shafts, they could not be identified as recycle streams.

The next step of the methodology was to understand the available data relating to the boundaries, streams and parameters. The availability of the data to define the streams and parameters of both Ring One and Ring Two is shown in Table 3.

Table 3: Available compressed air ring data

Ring	Supply-demand	Process Unit	Flow	Pressure
Ring One	Demand	4 #	Yes	Yes
Ring One	Demand	6 #	Yes	Yes
Ring One	Demand	11 #	Yes	Yes
Ring One	Demand	12 #	Yes	Yes
Ring One	Demand	14 #	Yes	Yes
Ring One	Demand	20 #	Yes	Yes
Ring One	Demand	11C #	Yes	Yes
Ring One	Demand	22 #	Yes	Yes

Ring	Supply-demand	Process Unit	Flow	Pressure
Ring One	Demand	Process Plant	Yes	Yes
Ring One	Supply	Compressor House 5B-CP01	No data	No data
Ring One	Supply	Compressor House 7-CP01	No data	Yes
Ring One	Supply	Compressor House 7-CP02	No data	Yes
Ring One	Supply	Compressor House 7-CP03	No data	Yes
Ring One	Supply	Compressor House 11-CP01	Yes	Yes
Ring One	Supply	Compressor House 11-CP02	Yes	Yes
Ring One	Supply	Compressor House 11-CP03	Yes	Yes
Ring One	Supply	Compressor House 12-CP01	Yes	Yes
Ring One	Supply	Compressor House 12-CP02	Yes	Yes
Ring One	Supply	Compressor House 12-CP03	Yes	Yes
Ring One	Supply	Compressor House 14-CP01	Yes	Yes
Ring One	Supply	Compressor House 14-CP02	Yes	Yes
Ring One	Supply	Compressor House 20-CP01	Yes	Yes
Ring One	Supply	Compressor House 20-CP02	Yes	Yes
Ring One	Supply	Compressor House 20-CP03	Yes	Yes
Ring One	Supply	Processing-CP01	Yes	Yes
Ring One	Supply	Processing-CP02	Yes	Yes
Ring One	Supply	Processing-CP03	Yes	Yes
Ring One	Supply	Processing-CP04	Yes	Yes
Ring Two	Demand	1 #	Yes	Yes
Ring Two	Demand	9 #	Yes	Yes
Ring Two	Demand	10 #	Yes	Yes
Ring Two	Demand	16 #	Yes	No data
Ring Two	Supply	Compressor House 1-CP01	Yes	Yes
Ring Two	Supply	Compressor House 1-CP02	Yes	Yes
Ring Two	Supply	Compressor House 1-CP03	No data	No data
Ring Two	Supply	Compressor House 2-CP01	Yes	Yes
Ring Two	Supply	Compressor House 2-CP02	Yes	Yes
Ring Two	Supply	Compressor House 9-CP01	Yes	Yes
Ring Two	Supply	Compressor House 10-CP01	Yes	Yes
Ring Two	Supply	Compressor House 10-CP02	Yes	Yes
Ring Two	Supply	Compressor House 16-CP01	Yes	Yes
Ring Two	Supply	Compressor House 16-CP02	Yes	Yes
Ring Two	Supply	Compressor House 16-CP03	Yes	Yes

Most of the required flow and pressure data were available, but there were limitations to the available data. The flow data of the 7 and 5B compressor houses are unavailable because they are older compressors with no space for measurement probes. Pressure data for the 5B compressor is similarly not available. The third compressor of House 1 is also an older model of which the pressure and flow data are not available. The pressure at 16 Shaft is unavailable due to instrumentation compatibility issues.

These missing parameters will limit the understanding of the process to an extent, but the available data will still be a reasonable representation of the process operation. The SCADA must be referenced with the collected information to understand the data.

ASPEN process data explorer was used to collect historical data. All the tags required to analyse the compressed air network were identified using the SCADA and could be found on ASPEN, except for the electrical consumption or power data. The power data could, however, be collected from a separate source, namely EI-Enterprise.

The required data was collected and is shown in Figure 24.

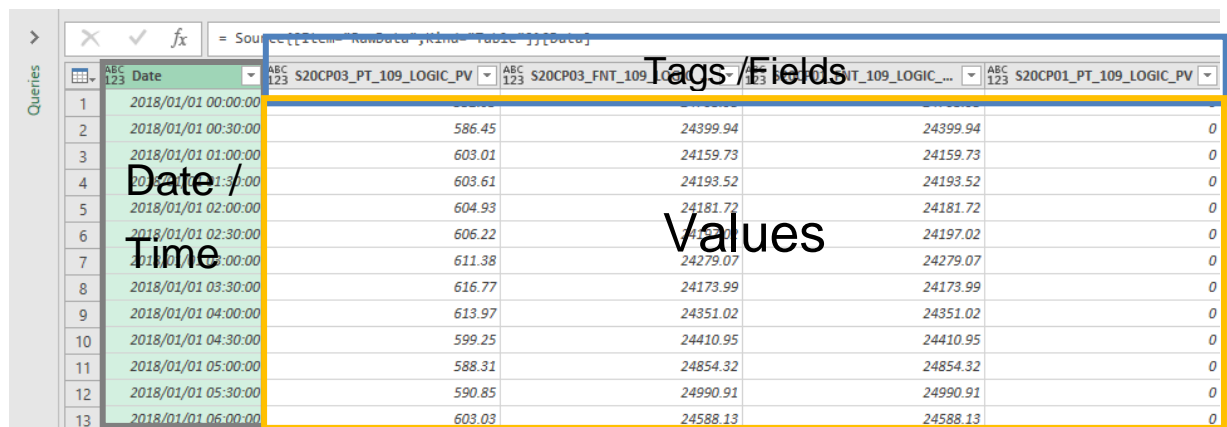

Date	Time	Tags/Fields	Values
2018/01/01	00:00:00		
2018/01/01	00:30:00		586.45
2018/01/01	01:00:00		603.01
2018/01/01	01:30:00		603.61
2018/01/01	02:00:00		604.93
2018/01/01	02:30:00		606.22
2018/01/01	03:00:00		611.38
2018/01/01	03:30:00		616.77
2018/01/01	04:00:00		613.97
2018/01/01	04:30:00		599.25
2018/01/01	05:00:00		588.31
2018/01/01	05:30:00		590.85
2018/01/01	06:00:00		603.03

Figure 24: Partial view of the database

The collected data consisted of the date and time, tags and values, as shown in Figure 24. It must be noted that the data is typically not found in the unpivoted form required by the methodology but will be available in the form shown above. The collected data is unstructured because the collected tags only indicate which meter generated the data. Structuring the data will require that the data be understood in the context of the energy reticulation. The data must be structured in a manner that it is accessible to a user with no prior knowledge of how the meter relates to the energy reticulation. After having collected the data and developed the process of understanding, the SADT method could be applied to structure the data. This was done by creating metadata tables. This is further discussed in the next section.

Summary

The distribution of the energy consumers was analysed to determine the initial focus of the case study. The compressed air network was selected because it was the most significant energy consumer. Layouts, documents and people were consulted to understand the process and its goal of supplying air to the various shafts and process plant. The level of analysis was

determined to be on the surface. Flow and pressure were identified as crucial parameters to analyse.

Unstructured energy reticulation data was collected from the site's SCADA and historian. The availability of the data was deemed sufficient to result in a representable view of the data. The knowledge generated must now be related to data and captured in a structure. This must improve access to the relevant data.

In Figure 25, the top row indicates a table. The table fields (columns) that are captured in the tables stem from the first row of the figure. The various colours used to identify repeating fields indicate how these tables are related to each other. Relationships between fields are thus shown by using matching colours. The developed result differs from the methodology template, as the template is meant to function as a guideline. Each table in the data structure developed above is being discussed in this section. The unstructured data is shown in Figure 24. A row from the energy reticulation information (B) is shown in Table 4, which represents a single measurement device.

Table 4: Mine A - Energy reticulation table

Tag Name	Description	Type	Supply-demand	Property	Operational unit	Unit #	Area	Ring	Data Source
S01CP02 _FT_110 _PV	Annubar Air Flow - Bank	Shaft flow	Demand	Flow	Shaft	1 #	1 #	Two	ASPEN

The tag (referring to a meter) shown above records the data of one shaft's flow demand. Information like the tag description (d) from the mine was added to the tag. The direction of energy flow through the boundary could be added by the supply-demand (h) field. Supply feeds to the compressed air ring while the ring feeds demand. The operational unit field (g) defines the level of analysis because these operational fields can define the boundaries – this means that the data can be filtered into specific groups of boundaries. The type (e) field indicates which streams are flowing through the boundary, but this field also provides a more generic categorisation.

The need for a more generic solution arose from the need to add components outside of the energy reticulation scope to the data structure. An example of these components is the guide vane angles of the compressors. The property field (f) specifies the parameter measured, such as flow, pressure, temperature or any of the additional parameters outside of the energy reticulation scope. The boundaries are defined by the ring (k), area (j), and unit # (i) fields. This facilitates the SADT method and the required levels of analysis, as shown in Figure 26.

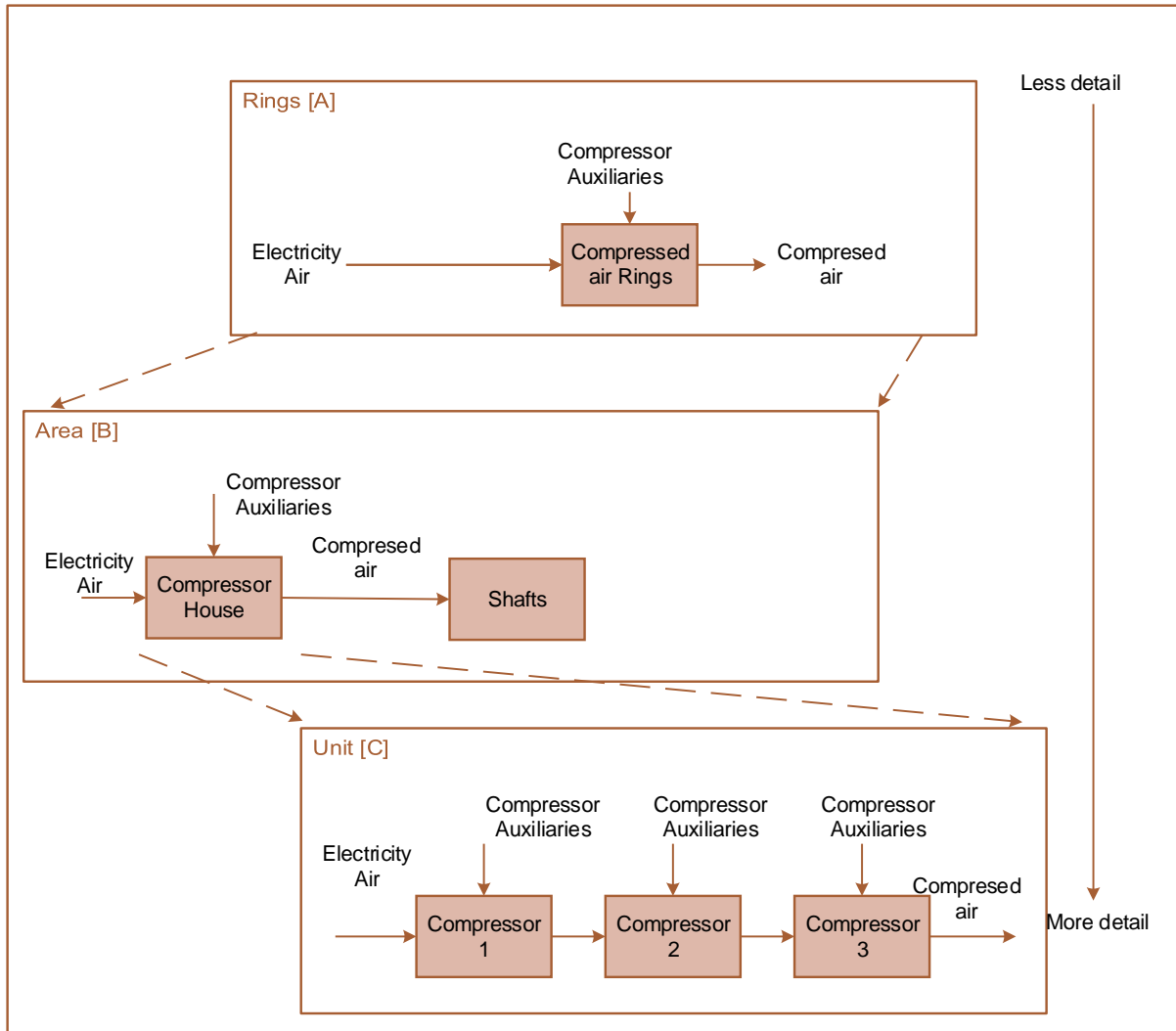

Figure 26: SADT method resulting example

The figure above shows how the SADT method was used to capture the energy reticulation knowledge from a high level with less detail to the process unit level with more detail. The first allocation used to define boundaries is whether the measurement device is on Ring One or Ring Two (A). Next, area (B) can be specified. This will determine which compressor house or shaft is being measured. Unit (C) allows for specific process units such as compressors to be defined. This means that the SADT method has been incorporated into the energy reticulation information (B) table. Refer to Section A.1.2 for the complete energy reticulation Table 11. The data source (I) could also be specified.

A unit of measure (E3) conversion table was required to ensure that the true meaning of the property information was captured in the data-structure. This information is captured in Table 5.

Table 5: Unit conversion table

Property	Unit	Factor
Pressure	kPa	1
Flow	Nm ³ /hr	1
Power	kW	1
Flow	kg/s	0.00034
Guide vane angle	%	1
Blow off	%	1
Temperature	°C	1

The unit identifies a unit of measure while the factor (z) converts a property (f) to another unit of measurement (y), should it be required. The compressed air flow value will only be changed if the unit change from Nm³/hr to kg/s. The data structure changes the factor used to multiply the value by selecting the unit of measure. The result is that the factor chosen to multiply the flow data with if Nm³/hr be chosen would be 1. Choosing kg/s would result in the conversion factor of 0.00034 being chosen.

The data problems (C) that were identified have been captured, as shown in Table 6. The data problems stem from meter problems and power outages. During power outages, data estimations are introduced. The process of estimating data can introduce errors, which must be kept track of.

Table 6: Data problems

Date time	Tag name	Data problem
2018/01/20 22:30	12 SHAFT COMPRESSOR SUB_5.1MW COMPRESSOR (kW Imp)	Power reading without flow
2018/01/20 22:00	11 SHAFT 6.6kV SUB_COMPRESSOR FDR1 (kW Imp)	Power reading without flow
2018/01/20 22:00	20 SHAFT 6.6kV SUB_COMPRESSOR FDR3 (kW Imp)	Power reading without flow
2018/01/20 20:00	20 SHAFT 6.6kV SUB_COMPRESSOR FDR1 (kW Imp)	Power reading without flow
2018/01/20 19:30	11 SHAFT 6.6kV SUB_COMPRESSOR FDR2 (kW Imp)	Power reading without flow
2018/01/20 19:30	11 SHAFT 6.6kV SUB_COMPRESSOR FDR3 (kW Imp)	Power reading without flow
2018/01/20 19:00	11 SHAFT 6.6kV SUB_COMPRESSOR FDR1 (kW Imp)	Power reading without flow
2018/01/20 09:00	20 SHAFT 6.6kV SUB_COMPRESSOR FDR3 (kW Imp)	Power reading without flow

By adding this information to the tags, the data can be used while keeping track of any data problems (m) that may have been identified through the process. The organisation of data

errors permits the user to keep track of the data being used. The data user can manage the uncertainty in data quality by using data problems table (C).

A rolling calendar was generated, as shown in Table 7, using the Power Query tool in Microsoft Excel⁸ and M-language⁶. A rolling calendar is a calendar which automatically adds new dates up until the current time and date. The date-time field allows the data to be relatable to any new data added to the data system⁷, by matching the automatically updated date-time field to the data's date-time field.

Table 7: Rolling Calendar

Date Time	Time	Date	Month name	Week of year	Day name	Weekday	Quarter	Date (Year)	Date (Quarter)
2019/07/01 00:00	00:00:00	2019/07/01	July	27	Monday	Weekday	3	2019	Qtr3
2019/07/01 00:30	00:30:00	2019/07/01	July	27	Monday	Weekday	3	2019	Qtr3
2019/07/01 01:00	01:00:00	2019/07/01	July	27	Monday	Weekday	3	2019	Qtr3
2019/07/01 01:30	01:30:00	2019/07/01	July	27	Monday	Weekday	3	2019	Qtr3
2019/07/01 02:00	02:00:00	2019/07/01	July	27	Monday	Weekday	3	2019	Qtr3
2019/07/01 02:30	02:30:00	2019/07/01	July	27	Monday	Weekday	3	2019	Qtr3
2019/07/01 03:00	03:00:00	2019/07/01	July	27	Monday	Weekday	3	2019	Qtr3
2019/07/01 03:30	03:30:00	2019/07/01	July	27	Monday	Weekday	3	2019	Qtr3
2019/07/01 04:00	04:00:00	2019/07/01	July	27	Monday	Weekday	3	2019	Qtr3
2019/07/01 04:30	04:30:00	2019/07/01	July	27	Monday	Weekday	3	2019	Qtr3
2019/07/01 05:00	05:00:00	2019/07/01	July	27	Monday	Weekday	3	2019	Qtr3

The rolling calendar allows for new data to be added daily. The calendar is automatically updated to the most recent date and time (b) for the data structure to adapt to any new data has been added. In addition to being able to select a specific date (o) or time (n), additional time-based information was deemed to be relevant filters of the data. This includes the month (p), the week of the year (q), the days of the week (r) and the quarter of the year (t). It was also necessary for both the operational analysis and seasonal analysis of the data that the weekdays/weekends (s)-days be specified along with the season (u).

⁶ Microsoft, Power Query M formula language, (accessed 2019/09/30): <https://docs.microsoft.com/en-us/powerquery-m/power-query-m-reference>.

⁷ S. Singh, How to create a Rolling Calendar? (published in 2018, accessed 2019/09/30): <https://businessanalyticswithpowerbi.com/how-to-create-a-rolling-calendar/>

The weekdays/weekends (s) and season (u) fields were also necessary to add the tariff information from the electrical energy supplier (E1). Figure 27 shows the Eskom Mega-Flex [53] tariff schedules, which depend on seasons, weekdays, weekends and certain times of the day.

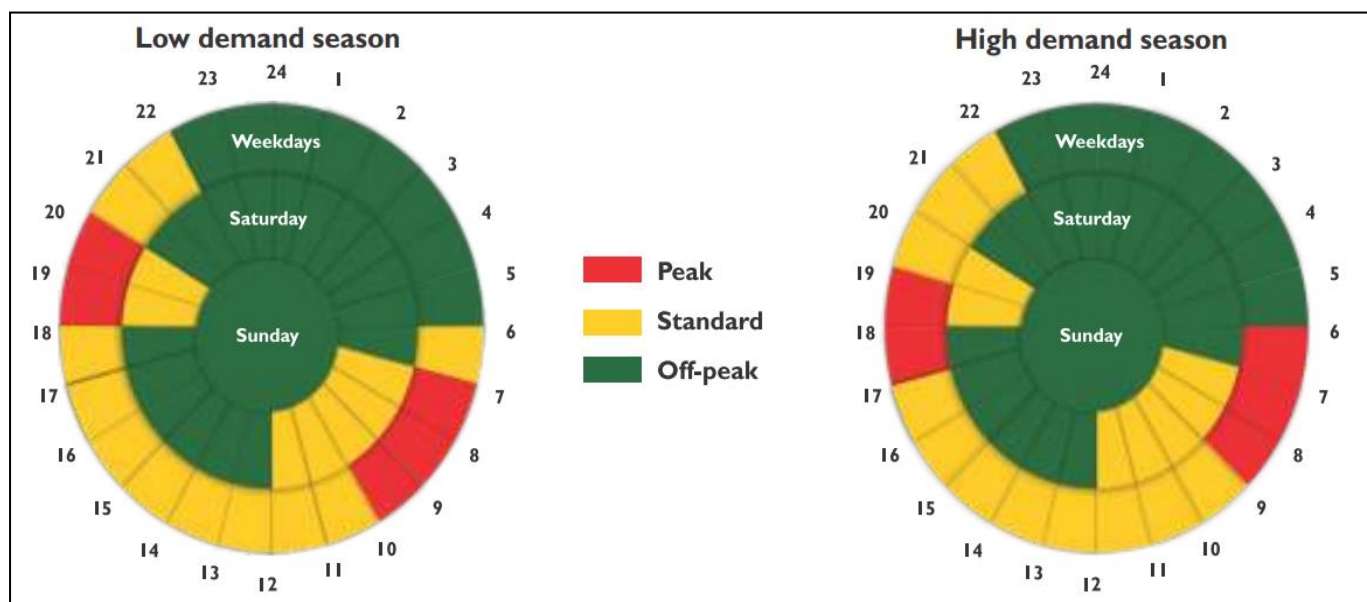

Figure 27: Eskom Mega-Flex Periods

The low demand seasons shown are further referred to as summer in this study, while the high demand is further referred to as winter. The days of the week are broken up into peak, standard, and off-peak times. The ESKOM tariffs differ for each season and each period throughout the days respectively. This is only applicable to the Mega Flex consumers on the grid. This information could be related to the data-structure and incorporated to calculate the cost of the electrical energy supplied from Eskom to Mine A. An extract of the energy supplier information table (E1) is shown in Table 8.

Table 8: Energy-supplier information

Time	Season	Weekday	Period	Tariff
00:00 – 06:00	Summer	Weekday	Off-peak	R 0.41
06:30 – 07:00	Summer	Weekday	Standard	R 0.65
07:30 – 10:00	Summer	Weekday	Peak	R 2.88
10:30- 18:00	Summer	Weekday	Standard	R 0.65
18:30 - 20:00	Summer	Weekday	Peak	R 2.88
20:30 - 22:00	Summer	Weekday	Standard	R 0.65
22:30 – 23:30	Summer	Weekday	Off-peak	R 0.41

The tariffs (v) and daily time-based periods (w) could be related to the time (n), season (u) and weekend/weekday (s) fields.

Additional information can be added to the data structure by creating an operational shifts (E2) table, as shown in Table 9.

Table 9: Operational shifts

Time	Shifts
22:00 – 06:00	Cleaning shift
06:30 – 16:30	Drilling shift
17:00 – 21:30	Blasting shift

The data structure was developed with the energy reticulation knowledge captured in the metadata tables. This data structure must be loaded into the data model using the Power Query tool (using the data ribbon in Excel) ⁸. To achieve this, the first step is to unpivot the unstructured data to permit the filtering capability of the data structure. The resulting change is that the table is unpivoted so that the date/time, tags and values are the only columns in the table (see Figure 28).

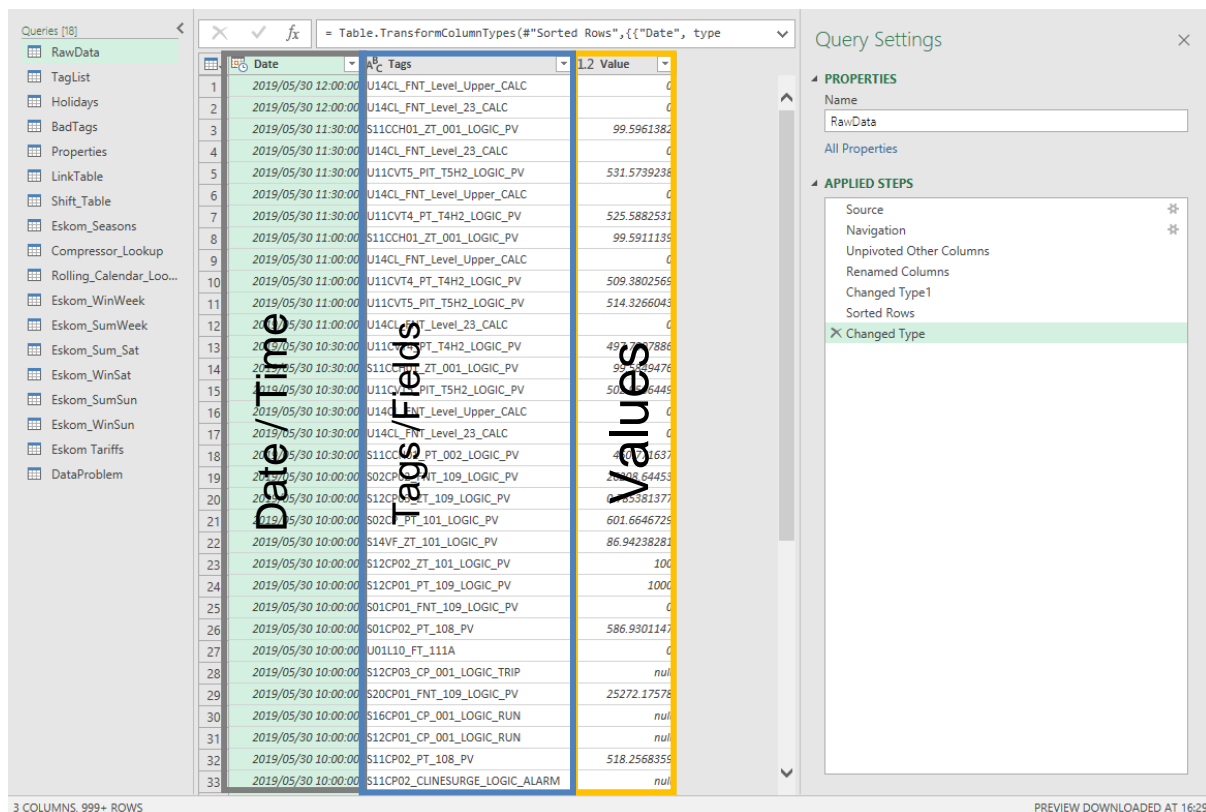

Figure 28: Unpivoted data

⁸ Microsoft, Introduction to Microsoft Power Query for Excel, (accessed 2019/09/30): <https://support.office.com/en-us/article/Introduction-to-Microsoft-Power-Query-for-Excel-6E92E2F4-2079-4E1F-BAD5-89F6269CD605> (accessed September 30, 2019).

The unstructured data is unpivoted so that the table only consists of three columns, namely date/time, tags/fields and values. This measure is necessary to filter the values based on the date/time and tags. Power Query was used to unpivot the data without requiring intensive data management. The metadata tables were then related to the data table, as shown in Figure 29.

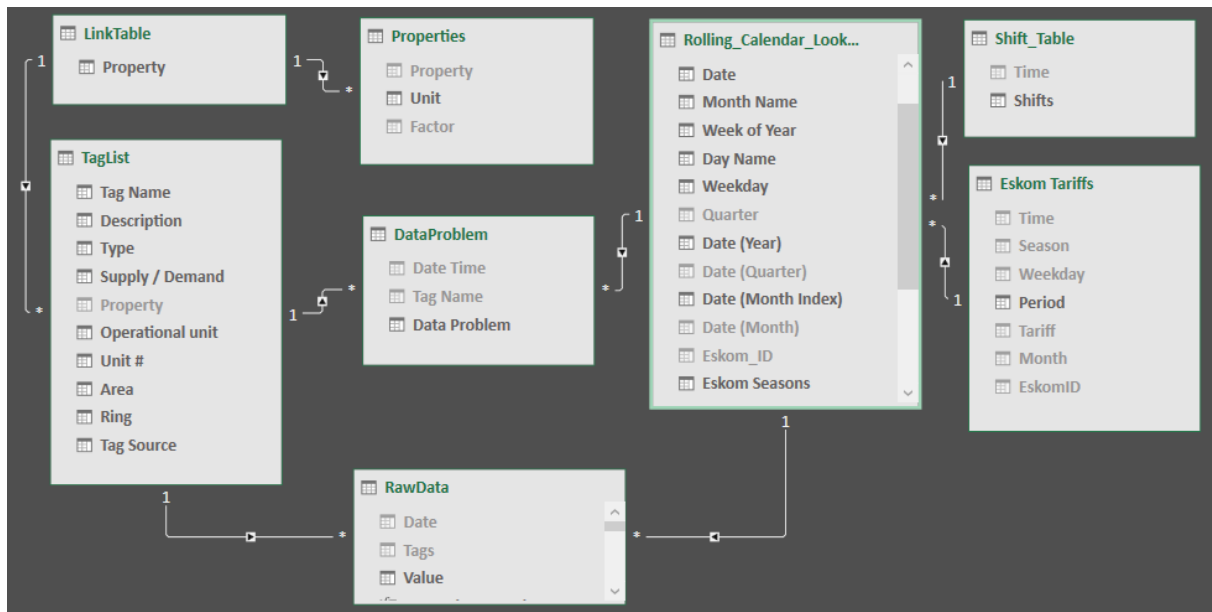

Figure 29: Structured data model (Related tables)

Figure 29 shows that the fields and data have been related. The RawData table is the unpivoted and unstructured data. The created relationships flow towards this table. The knowledge captured in the other tables will therefore be used to filter this table. The TagList table is captured the energy reticulation information. If any of the TagList fields are filtered to chosen values, the tag field of the RawData table will also be filtered, thus leaving the required values behind.

The properties table filters the TagList table, which then filters the data table. A LinkTable was required because a field without repeating row values is required for the model to work seamlessly. The LinkTable was thus used to define which properties are available. The DataProblem table filters both the calendar and TagList tables, which then identifies the relevant data in the data table.

The Rolling_Calendar_Lookup table allows the date/time field in the RawData to be filtered. This is similar to the tags being filtered by the TagList table. The Eskom Tariffs and Shift_Table was added to the rolling calendar table. This additional information adds additional insight into the data.

Tables must thus be related in an order that results in a sensible structure when the data is filtered and aggregated. It is recommended that the data table should be at the bottom of the model. When a specific value is filtered in a metadata table, the metadata table's tags are filtered, which resultantly filters the tags of the unpivoted data. This chain of filters leaves in the required values, which can now be aggregated as desired. The structured data model can then be utilised in pivot tables and visualisations, creating dynamic views of the data.

Summary

The developed solution was used to construct a data structure compiled with energy reticulation information. A unit conversion table was added to preserve the true meaning of the data values. Data problems were organised and related to the data. A rolling calendar was built to allow the data structure to be continuously utilised. Eskom tariffs were also added to the data model. The unstructured data was related to the data model, using PowerPivot and Power Query. The result is a structured data model which can be updated with new data thanks to the rolling calendar.

Access to the data has been improved, but in order to enable observations, this data must be visualised and filtered by the data structure. These observations should lead to energy management through the resulting actions.

3.4 Enable energy management

The structured data model must be visualised to enable energy management. Figure 30 is a dashboard that allows the user to access the data as described by the metadata tables. The mass and energy balances, according to the defined boundaries and flow convention, can be critically analysed as a numerical check of the energy reticulation understanding.

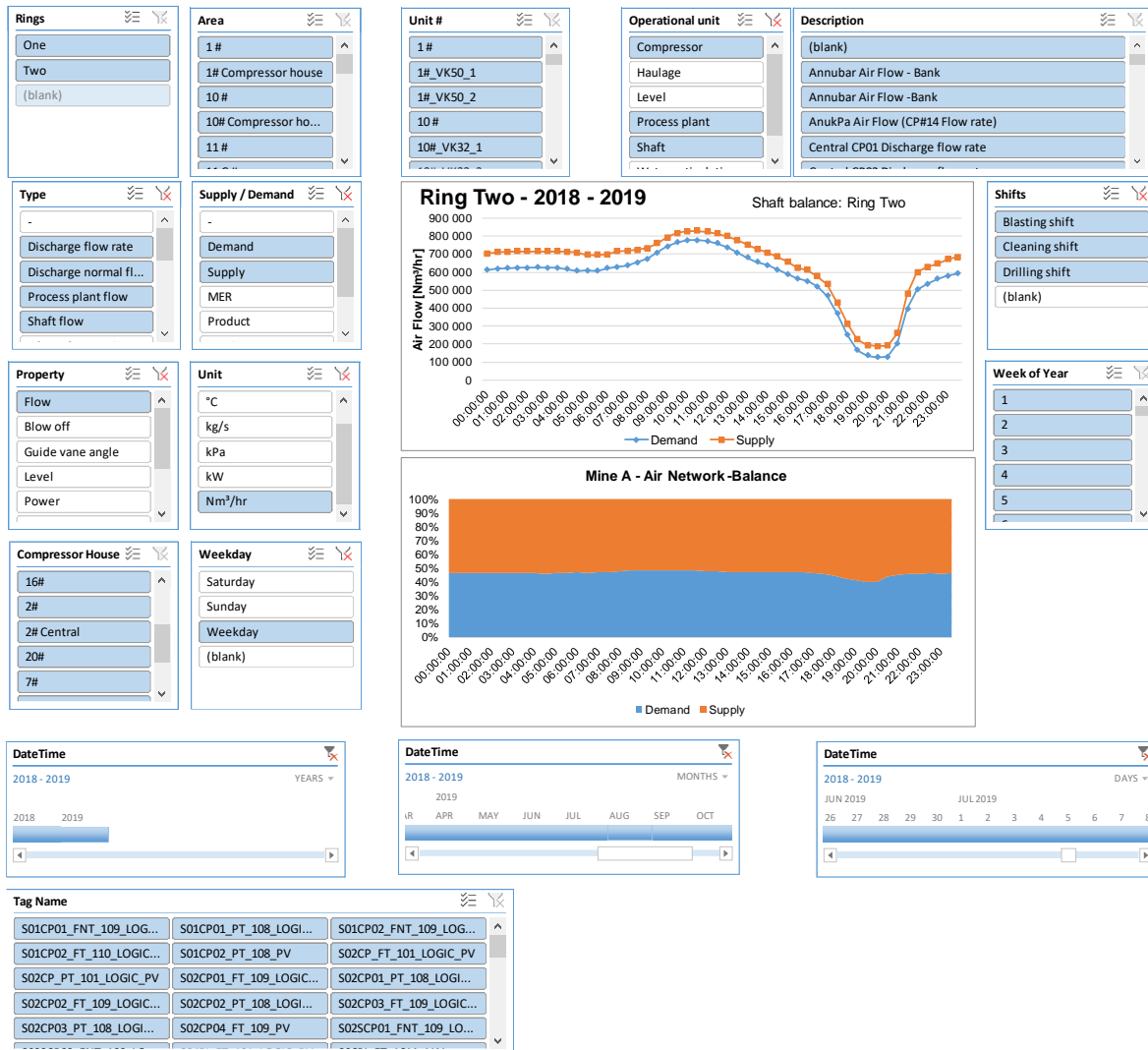

Figure 30: Balance dashboard

The data structure now allows multiple views of the data. Each slicer in the dashboard above is derived from a field in the tables of the data structure. The information captured in the metadata tables can thus be used to filter the data. As an example, the user can toggle between the rings by selecting either “One” or “Two” on the “Rings” slicer.

These slicers allow the user to filter through the boundaries by selecting rings, operational units, areas and units. The user can select streams by selecting whether the supply or demand streams must be filtered. In addition to being able to filter through the energy reticulation

information, specific date and time information can be used. In Figure 30, the daily periods are shown and the desired year, month, week or day can be selected. The user can also differentiate between weekdays and weekends as well as the operational shifts. In order to ensure traceability to the original data tags, the tags chosen by the filters are shown in the tag slicer. Different dashboards, such as in Figure 30, can be built for different goals, as shown in Appendix A.1.1. The data access aids observations.

The observation which can be made from Figure 30 is that the supply for the Two Ring matches the demand. Hence, it can be concluded that the mass balance for the Two Ring has been captured accurately in the data structure. The average of the daily profiles also indicates the compressed air usage during the various operational shifts. The profile has a low consumption during the blasting shift (from 17:00 to 21:30), but an unusually high consumption during the cleaning shift (22:00 to 06:00) [48].

The energy managers developed a strategy to lower the ring pressures in order to reduce electrical energy consumption during the cleaning shift. From the nature of the process, lowering the flow consumption results in the reduction of electrical energy consumption. Reduced pressure on the rings reduces the supply flow, therefore resulting in less energy consumption. This must, however, be based on historical data to account for the technical limitations of the network and systems. The analysis of the historical data has been implemented using the data structure. The result is shown in Figure 31, which compares the pressure and flow for ring one between 2018 and 2019.

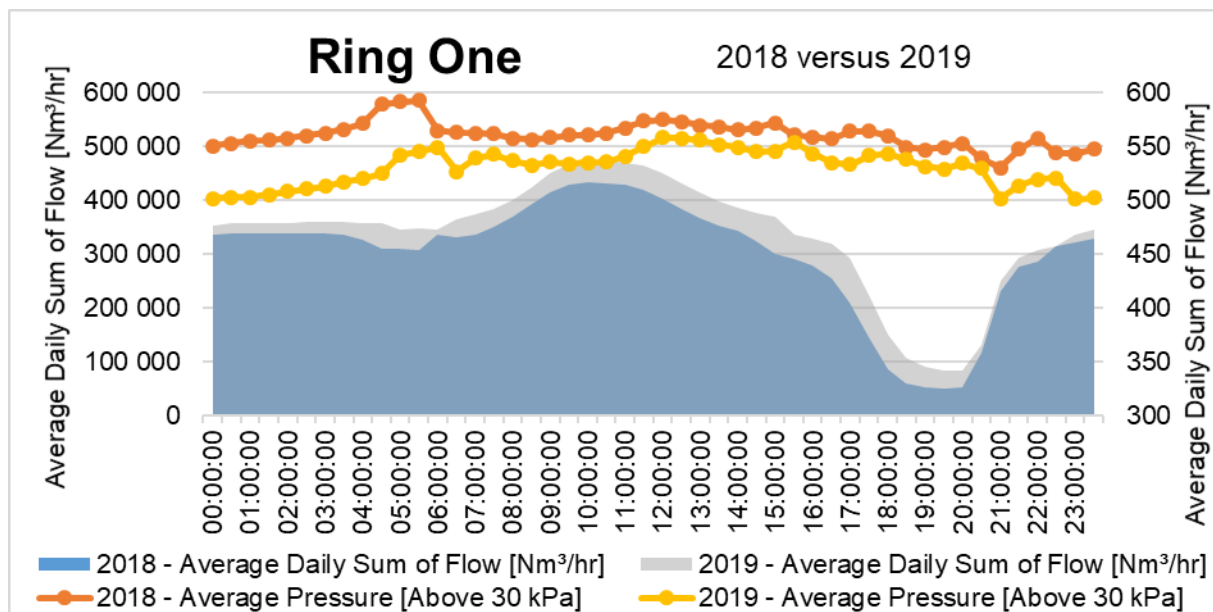

Figure 31: Ring One - 2018 profiles versus 2019 profiles

The flow (area graph) and pressure (dotted lines) data were aggregated by taking the average value for each year at half-hour intervals throughout the day. The result of this aggregation is an average daily profile for each year. Weekdays were chosen, thus excluding Saturdays and Sundays. The blue area graph represents the 2018 flow, while the transparent grey area graph represents the 2019 flow.

The 2018 pressure for ring one (orange) is higher than the 2019 pressure for Ring One (yellow line), especially for the cleaning shift (22:00 to 06:00) and thus indicates that the energy manager’s initiative has been implemented but the flow has increased. The 2019 flow for Ring One (the grey area) is higher than the 2018 flow (blue area), but it must be noted that this increase is lower during the cleaning shift. This behaviour indicates that the demand for the ring has increased, but that the increase was limited by the energy managers strategy.

The increase in flow, despite the pressure reduction, is an unexpected observation. It was, however, known that during the period from 18 February 2019 to 20 March the operational structure of Ring One was changed. An additional pipeline was added to 11C Shaft, the decline section of 11 Shaft, in order to improve the lower section’s pressure. The resulting flow increase is shown in Figure 32.

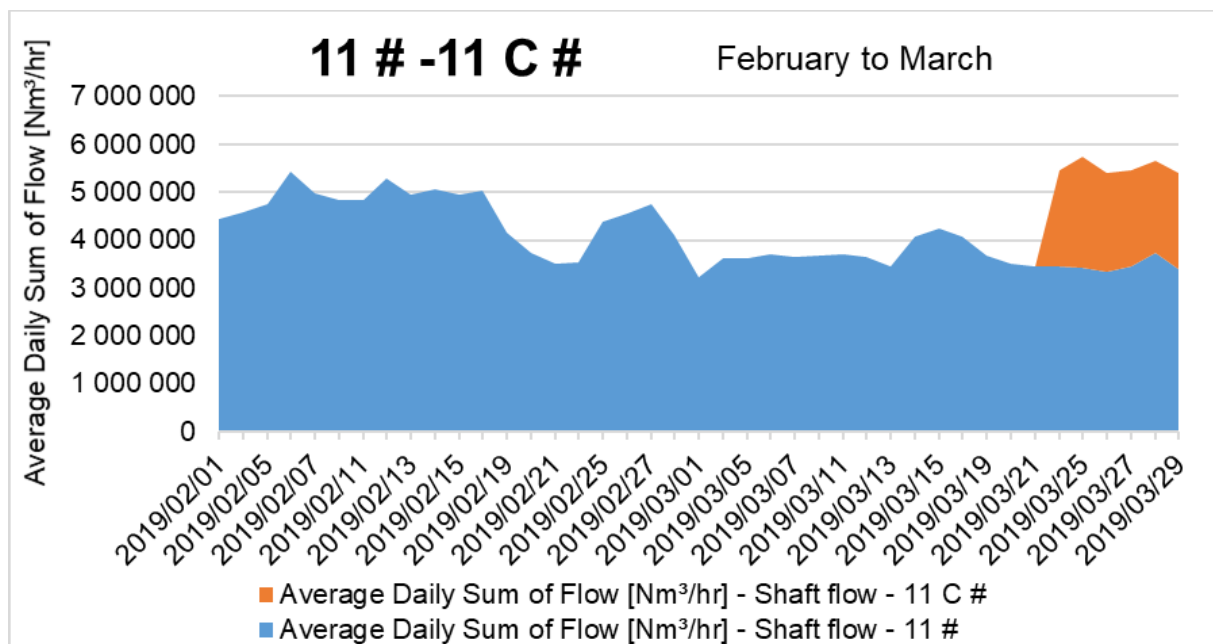

Figure 32: 11# increase in consumption due to the addition of 11C# pipeline

11C Shaft used to received air from 11 Shaft directly, but the low pressures at the lower levels resulted in the installation of a new pipeline. It can be detected from Figure 32 that the 11C Shaft pipeline was installed in February, even though it was only measured from March. This observation is due to the drop in flow seen for 11 Shaft (blue area) from February, 18. The

flow supplied to 11 Shaft also drops due to the flow which was sent to 11C Shaft (orange area) instead of on March, 20. This observation was confirmed by site personnel. Figure 33 shows the influence of the additional flow of 11C Shaft to Ring One.

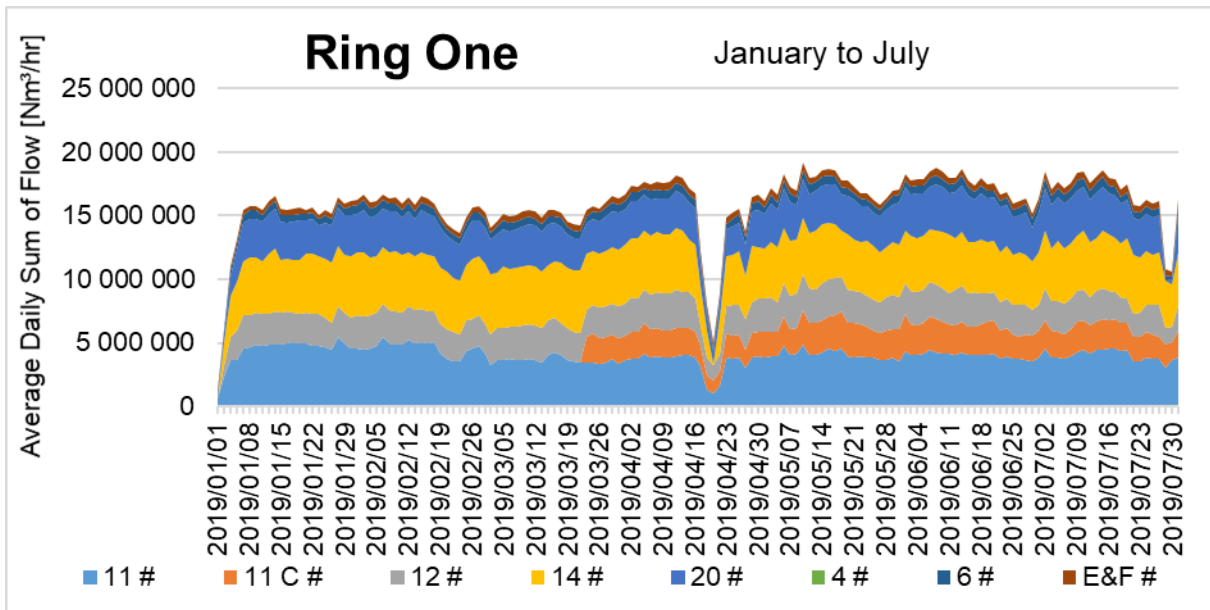

Figure 33: Ring One addition of 11 C#

The increase in the measured consumption is ascribed to the additional air going to 11C Shaft (orange area). Relating the change at 11 Shaft to the increased demand of Ring One confirms that increase in demand for Ring One was caused by a change in the operational structure of the ring. The initiative was also implemented on Ring Two. Figure 34 shows the pressure reduction initiative implemented on Ring Two.

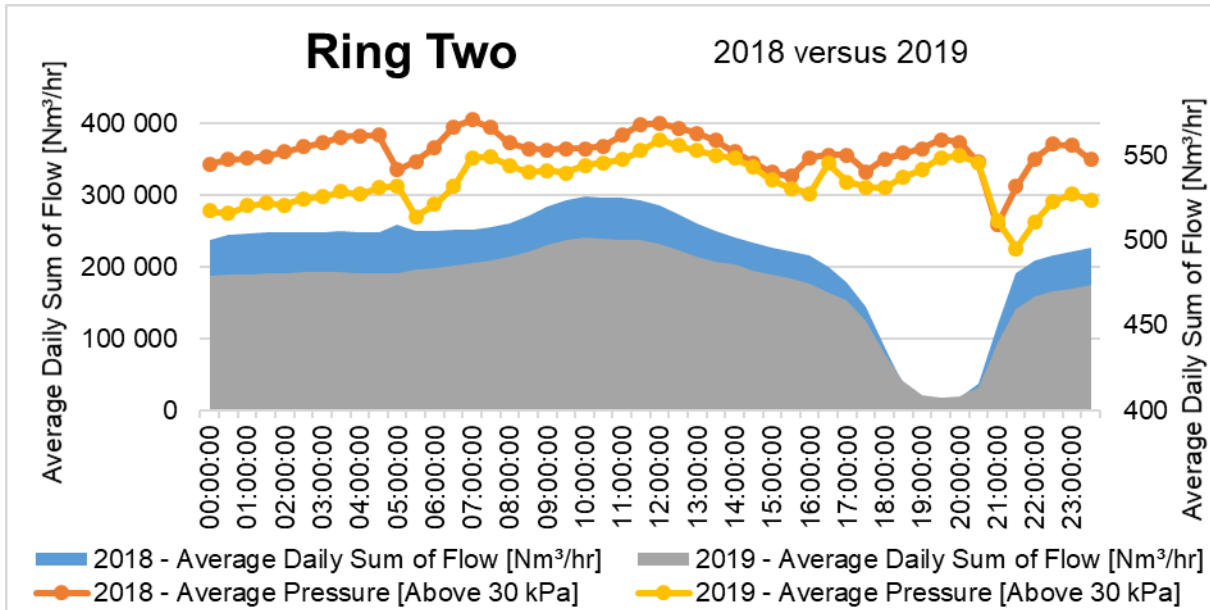

Figure 34: Ring Two - 2018 versus 2019 profiles

The structured data model was utilised to change the data used in Figure 31 to show the average daily flow and pressure profiles for Ring Two. The 2018 pressure for Ring Two (orange line) is higher than the 2019 pressure for Ring Two (yellow line), especially for the cleaning shift. The 2019 flow for Ring Two (the grey area) is lower than the 2018 flow (blue area).

The pressure reduction strategy implemented for Ring Two resulted in reduced flow consumption, as expected. This confirms that the energy-saving strategy works.

The observations made by the energy managers were not limited to additional consumers and the implemented strategies. The influence of previous projects could also be seen. An example of these projects is the control valve at 14 Shaft, as shown in Figure 35.

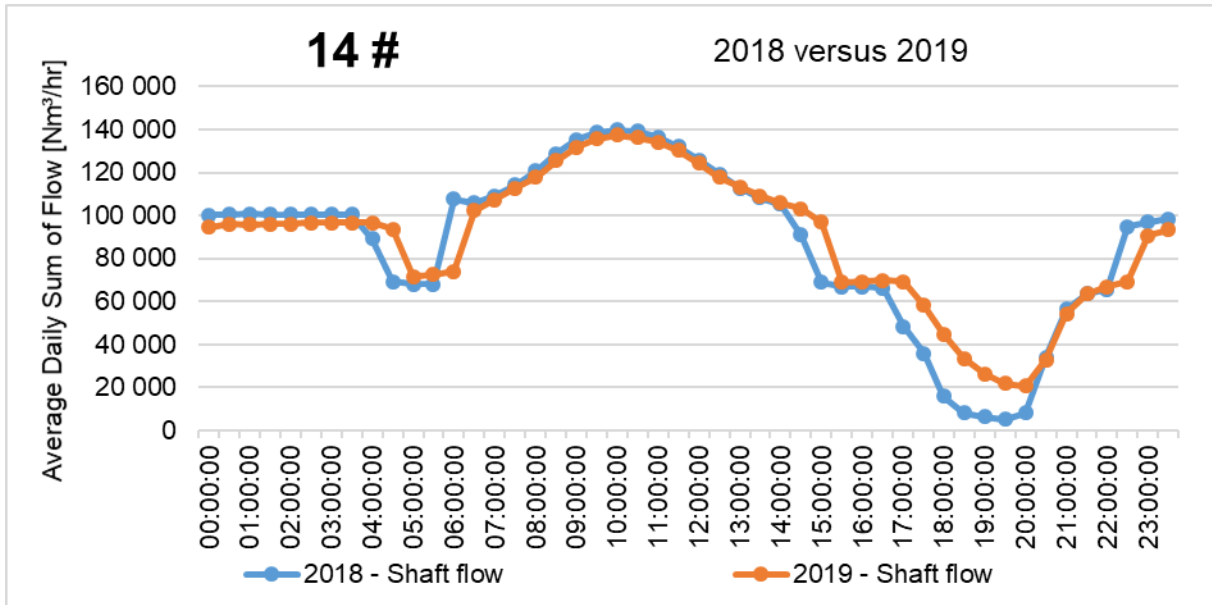

Figure 35: 14# control valve observation

The daily flow profile for 14 Shaft is shown, with the 2019 flow (orange line) and 2018 flow (blue line) showing changes in the shafts operational schedule. The shifts have been moved half an hour earlier. During the blasting shift (17:00 to 21:30), an additional production shift has been implemented on the shaft, thus resulting in the need for increased air consumption.

The control strategy for 2019 can be observed in the reduction in flow during the period from 04:30 to 06:00 and from 15:00 to 22:00. During the period from 17:00 to 21:30 blasting shift occurs resulting in the occasional closure of the surface valve, when the shaft has been cleared of personnel. The effect of the control valve can also be seen in Figure 36.

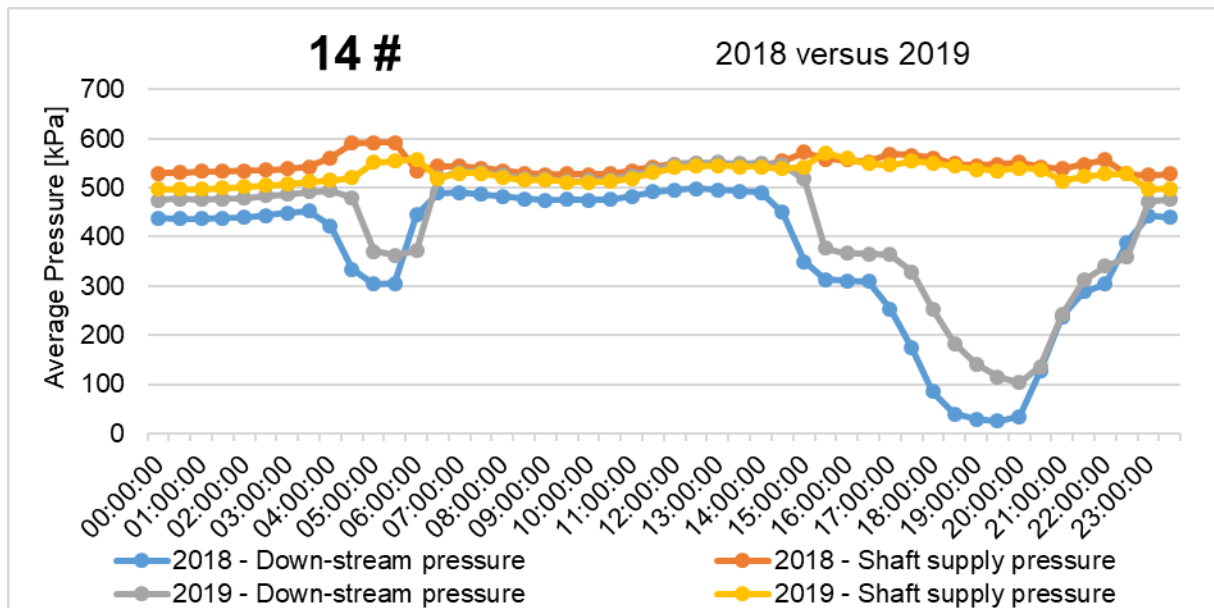

Figure 36: Supply pressure versus down-stream pressure

The difference between the supply pressure and down-stream pressure shows the effect of the control valve. The pressure reduction initiative can be seen, with the supply pressure for 2019 (yellow line) being lower than the supply pressure for 2018 (orange line). The increase from the 2018 downstream pressure (blue line) to the 2019 downstream pressure (grey line) indicates that the control philosophy can be updated. The down-stream pressure was lower in 2018; thus, the compressed air demand of the shaft decreased in 2019.

An energy-saving can be seen by either updating the valve's flow set-points or changing the control to be based on the pressure. The result being that the existing energy-saving strategy can be improved with an 8% reduction in flow as expected. The developed visualisations, therefore, facilitated the improved energy management of the valve. The strategy was controlled and organised with the assistance of the data structure.

Demand-side management strategies could also be developed, such as with the detection of 12 Shaft's faulty valve. It was noted that 12 Shaft consumes 20 000 Nm³/hr during the blasting shift. This was supposed to be 0 Nm³/hr because the control room confirmed that the shaft was clear of personnel. The additional flow requirement resulted in the need to run a 5-MW compressor instead of a 3-MW compressor. This 2-MW difference occurs during peak ESKOM tariff hours, for two hours of the day. The result of this is an additional cost of R 3.5-million per annum. This increase in flow was found to have started on June 18, 2018, as shown by Figure 37.

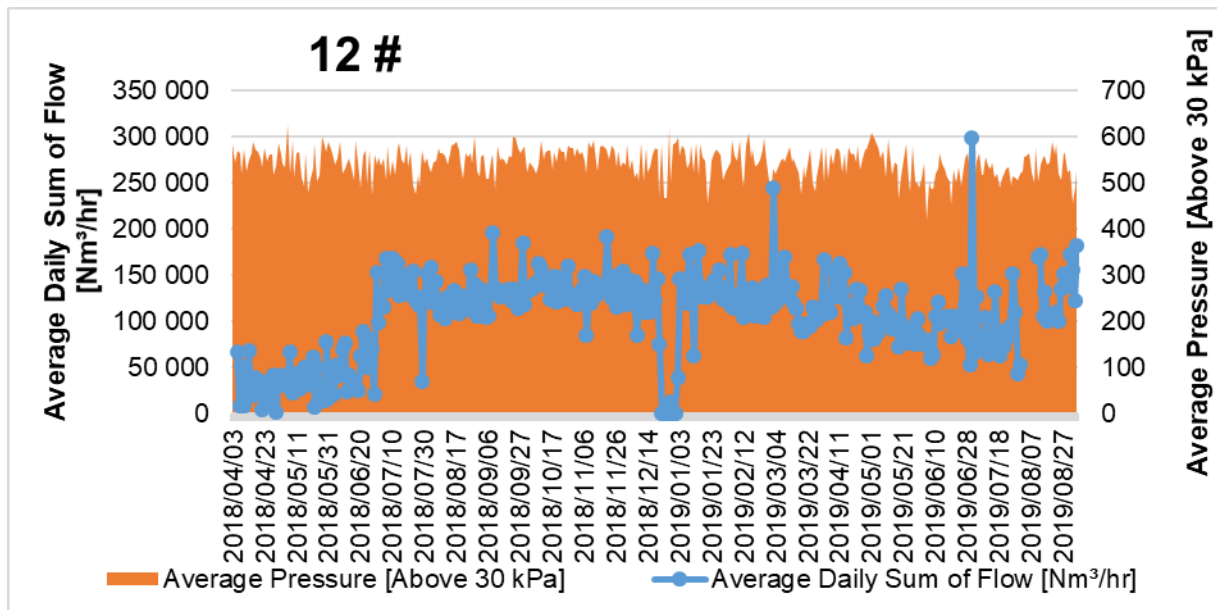

Figure 37: 12 # flow during blasting shift

The flow shown in Figure 37 ought to be 0 Nm³/hr during the blasting shift. The cause of the increased flow (blue line) required investigation, especially since the pressure (orange area) did not change significantly. The pressure is a result of the running compressors, which indicates that additional compressors were used to supply the required flow during this time. Using the boundary hierarchy from the SADT method, the flow increase could be allocated to Level 20 A by drilling down into the shaft's boundaries. Drilling down means moving from a high level of analyses to a more detailed level of analysis. In this case, the levels of analysis used to structure the data were moving from the shafts on the rings to the different shaft-levels. The compressed air consumption of the levels of 12 Shaft, during the blasting shift, is shown in Figure 38.

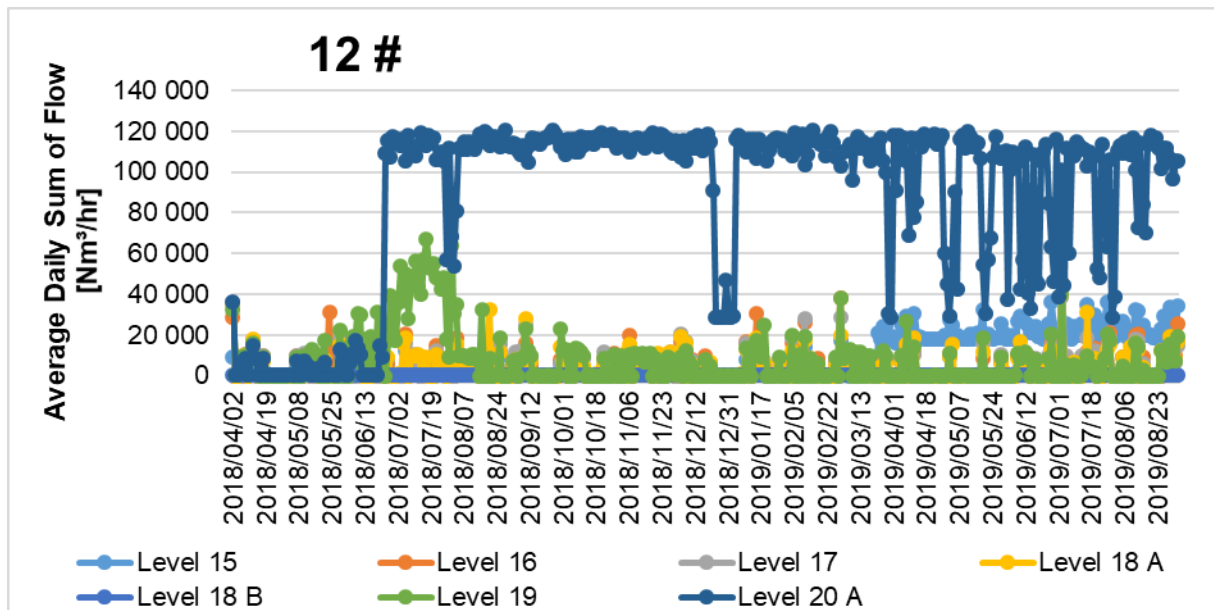

Figure 38: Level 20 A flow increase, during blasting shift

It can be seen in Figure 38 that the dark blue line of Level 20 consumed up to 120 000 Nm³ of air per day. The green line of Level 19 showed a peak at 70 000 Nm³ per day but was quickly rectified. Level 15 showed an increase in consumption of 30 000 Nm³ per day from April to August.

Level 20 A (dark blue line) can be seen to be the reason for the increased flow at 12 Shaft. A manual valve was closed on several days. The dips in Level 20 A's flow indicates the closure of the manual valve, resulting in a daily saving of 15 000 Nm³/hr for five hours. This relates to an R 2.6 million saving per annum because the air is consumed during the Eskom afternoon peak periods. In order to reduce the cost of wasted energy, it was recommended that Mine A replace the faulty valve.

Summary

The data structure was used to visualise the data using PowerPivot. The understanding of energy reticulation could be verified using the mass and energy balances captured in the data structure. The improved data access was used to implement newly developed strategies. The energy-saving strategies developed were in the form of pressure reduction initiatives.

Controlling the implementation of these strategies required continuous data analysis. The structure adjusted itself to additional data that was added because of the rolling calendar. The structure also adapted to the growing knowledge of the system throughout the process. Information was, therefore, continually organised by relating information to the data in organised tables. Access to data and the capturing of analysis in dashboards can be used to

create a culture of using data to drive decisions. As an example, a faulty valve which leaked air at the cost of R 3.5-million per annum was noted. An observation was made, due to improved data access. This led to an action, which means that energy was managed. The management of energy was, therefore enabled by the data structure, which captured energy reticulation knowledge.

3.5 Conclusion

This chapter applied the methodology to a practical case study on a platinum mine's compressed air network. Energy reticulation information was gathered and systematically analysed. The level of analysis and crucial parameters were identified. Unstructured energy reticulation data was collected from the site's SCADA and historian and the data's availability was deemed sufficient for it to result in a representable view of the data.

By using the developed solution, a data structure was built using the energy reticulation information compiled. The unstructured data was related to the data model, using PowerPivot and Power Query. The result was a structured data model, which captured the energy reticulation knowledge in a traceable and adaptable data structure.

The structured data structure was used to visualise data according to the knowledge obtained from the process information and understanding. The data access that resulted from the visualised data allowed the user to make energy management observations. These observations allowed for the development and implementation of energy-saving strategies.

The data structure, which captures energy reticulation knowledge, thus makes energy management possible.

CHAPTER 4: CONCLUSION

4.1 Summary of study

Energy management

Energy management is critical due to both the energy and environmental costs that relate to energy efficiency and management gaps. This study focused on the energy management gap. Energy management requires an understanding of energy reticulation and has more recently become reliant on data management which has, due to the complex interactions of processes within an industrial site, made energy management challenging. Various parameters and factors should be considered, thus resulting in a large amount of data that must be processed. In addition to these inherent challenges, defining KPIs and communication with multidisciplinary personnel adds to the challenges. The ISO 50001 standard presents a guideline to energy management.

The ISO 50001 standard is dependent on the effective collection and management of data. The technical understanding of the energy flow through the site is required. This understanding must be communicated by using the available data to enable efficient energy management. Clearly, an energy management framework must be based on data. The energy manager has must consider a broad scope of factors and variables when designing a framework to enable energy management.

The collected data is to be structured through mass and energy balances using the SADT method. The organised and managed energy reticulation information, along with the accounting framework, resulted in the development of energy reticulation knowledge.

Data structuring

Data management is directly dependant on the measurement of the process in question. The data is only useful once understood in its process' context. Information must, therefore, be organised and related to the data. Creating a data structure to organise information and relate the information to data is, however, challenging due to the availability of many data fields, information and knowledge describing a complex industrial process.

ICT and standardisation play essential roles as enablers for the energy-efficient operation of processes, through access to data. Currently, rigid data structures are used in energy management, but metadata allows for the creation of adjustable structures. Adjustability results in the continuous organisation of the data, allowing the relevant data to be accessible.

The need to manage energy by continuously managing the data context has led to the problem statement:

Data must be structured to capture energy reticulation knowledge in such a way that the relevant data is accessible and enables energy management.

To address the need for continuous management in the context of the data, a framework was developed to collect and compile data and information through mass and energy balances. To this end, the structured analysis and design technique (SADT) method was used.

Classification schemes were consulted on the efficient use of data in order to ensure that the data system was formalised and structured appropriately. Facet analysis would inform the design of the data system to empower access to the relevant data by relating energy reticulation knowledge to the data because it results in an adjustable data structure, which is created by the energy manager. The tables were then related to each other using an ICT tool.

This resulted in an adjustable data structure, which was created by the energy manager.

Enabling energy management

The developed data structure captured the relevant information and data in an adjustable data-structuring framework, thus achieving data accessibility. However, to enable energy management, the data must be visualised. Therefore, the data structure was used to visualise the data using PowerPivot. The energy reticulation understanding could be verified using the mass and energy balances captured in the data structure. The observations from the visualised data were then used to perform actions, which in turn enabled energy management.

The developed data structure could assist with the implementation of strategies, which could be controlled through data-driven decisions. This was shown using a mining compressed air case study. The developed data structure captured the energy reticulation knowledge of two compressed air rings. The resulting data access then resulted in energy management observations which enabled energy management through the development, implementation and control of energy-saving strategies. The continuous organisation of the data in accordance with its energy reticulation context resulted in the sustainable use of the data analyses.

The energy-saving strategies developed were in the form of pressure reduction initiatives. Continuous data analysis was required to control the implementation of these strategies. The structure adjusted to additional data being added because of the developed rolling calendar. The structure also adapted to the growing knowledge of the system throughout the process.

Information was, therefore, continually organised by relating information to the data in organised tables. Access to relevant data, when visualised, leads to energy management observations. These observations lead to actions, resulting in the management of energy.

Verification

To verify the study, the study objectives are considered and compared to the results.

The first goal was to capture energy reticulation information in the data structure. An understanding of the process can indeed be continuously captured in the developed data structure. Energy audits aggregate from a detailed view to a high-level view. Mass and energy balances were used to aid energy audits and quantified the understanding of the energy reticulation.

Data is traceable to the measurement point because this is where the design of the energy reticulation table begins. Information from various sources, including layouts, drawings, people, events were used.

The energy manager can define the data by editing the metadata table or the data model. The rolling calendar table and the energy reticulation tables allow the data to be clearly defined. All the relevant energy governing factors can be made available and accessible, given that the data is available.

The metadata tables are simple and easy to edit. The formalisation through the six design steps for facet analysis allows the user to define the data but is given enough guidance through the fields in the prescribed tables. Facet analysis could be fully used to manage metadata. The framework permits a centralised data system to remove unnecessary knowledge capturing solutions within an organisation. This system, however, depends on the adoption of its use to be functional.

The benefits of structured data are in line with the energy management scope. The data structure was used to visualise the data using PowerPivot. The improved data access was used to implement newly developed strategies. The energy-saving strategies developed were in the form of pressure reduction initiatives. Continuous data analysis was required to control the implementation of these strategies. The structure adjusted to additional data being added because of the rolling calendar. The structure also adapted to the growing knowledge of the system throughout the process. Information was, therefore, continually organised by relating it to the data in organised tables. Access to data and the capturing of analysis in dashboards can be used to create a culture of using data to drive decisions.

Therefore, it can be concluded that the results verify that the objectives were met.

Validation

In order to validate the study, the problem statement must be addressed. Data must be structured to capture energy reticulation knowledge in such a way that the relevant data is accessible and enables energy management.

The development, implementation, control and organisation of the pressure initiatives validated that the data had been structured to capture energy reticulation knowledge. The faulty valve that leaked air at the cost of R 3.5-million per annum validated that the relevant data was made accessible. Therefore, the data structure enabled the management of energy, which captured energy reticulation knowledge from a mining case study.

The enabled scope of energy management has mostly been validated, except for the culture of energy management, which still depends on the further adoption and long-term implementation of the developed solution. The author is, however, optimistic that the data structure developed can indeed enable energy management by making the relevant data accessible.

4.2 Recommendations

Energy management is an ever-evolving field, and continuous improvement is therefore needed. The data structure can be expanded to address this aspect of energy management in a more direct manner. Access to the relevant data and capturing analysis in dashboards is only a starting point towards creating a culture of using data to save energy, which is done through data-driven decisions. It is recommended that the framework should be used to further validate the sustainability of the knowledge captured. This can be done by means of improved focus on the front end of the data structure (visualisation), which was not the main focus of this studies scope.

The learning curve mentioned with regards to using the business intelligence software, as well as the use of Microsoft Excel Tools, should be further investigated. It is possible that the learning curve might be mitigated by means of early introduction to the new generation of energy managers.

The design of the tables can be improved through database normalisation. This would improve the efficiency and performance of the tables in the chosen ICT environment. In addition to improved database design, newer technologies in the ICT field can improve or change the implementation of this study. Examples of these technologies include expert systems [54], ontologies [55] and programming skills in general.

Information obtained from prediction models, evaluations and reports can be added to the data structure through additional tables. This would improve the modelling and evaluation of the impacts of energy initiatives. In addition to the improved analysis, a platform to train new personnel on the knowledge embedded in the data structure is provided.

Power BI is a powerful tool which was identified by this study to be valuable. The developed solution can be seamlessly imported into PowerBI⁵. Improved visualisations and a more diverse pool of data sources in the process of extracting, transforming and loading data is expected to add to the potential of this study. Further investigation into business intelligence software can also add to this study.

Continuous changes will not only improve energy management but also encourage sustainable growth. Captured information presents the opportunity to understand the different aspects of the industrial processes in more detail while ensuring that the knowledge is kept when contained in a defined structure.

REFERENCE LIST

- [1] P. W. O’Callaghan, S. D. Probert, “Energy management”, *Applied Energy*, vol.3, no.2 pp.,127–138, 1977. [https://doi.org/https://doi.org/10.1016/0306-2619\(77\)90024-1](https://doi.org/https://doi.org/10.1016/0306-2619(77)90024-1).
- [2] M. Schulze, H. Nehler, M. Ottosson, P. Thollander, “Energy management in industry - A systematic review of previous findings and an integrative conceptual framework”, *Journal of Cleaner Production*. vol. 112, no. 5, p. 3692–3708, 2016. <https://doi.org/10.1016/j.jclepro.2015.06.060>.
- [3] Republic of South Africa, “Act No. 15 of 2019: Carbon Tax Act”, *Government Gazette*, 647(42483), pp. 1-65, 2019.
- [4] South African National Treasury, “Regulations in terms of section 12L of the South African Income Tax Act of 1962”, *Government Gazette*, 2009(33385), pp. 71-79, 2019.
- [5] B. Jovanović, J. Filipović, “ISO 50001 standard-based energy management maturity model - Proposal and validation in industry”, *Journal of Cleaner Production*, vol. 112, no. 4, pp. 2744–2755, 2016. <https://doi.org/10.1016/j.jclepro.2015.10.023>.
- [6] K. Bunse, M. Vodicka, P. Schönsleben, M. Brühlhart, F. O. Ernst, “Integrating energy efficiency performance in production management - Gap analysis between industrial needs and scientific literature”, *Journal of Cleaner Production*, vol. 19, no. 6-7, pp. 667–679, 2011. <https://doi.org/10.1016/j.jclepro.2010.11.011>.
- [7] A. Amundsen, “Joint management of energy and environment”, *Journal of Cleaner Production*, vol. 8, no.8, pp. 483–494, 2000. [https://doi.org/10.1016/S0959-6526\(00\)00018-4](https://doi.org/10.1016/S0959-6526(00)00018-4).
- [8] R. Kannan, W. Boie, “Energy management practices in SME — case study of a bakery in Germany”, *Fuel and Energy Abstracts*, vol. 44 ,no.4, pp. 266, 2003. [https://doi.org/10.1016/S0140-6701\(03\)82243-9](https://doi.org/10.1016/S0140-6701(03)82243-9).
- [9] Association of German Engineers, “Ingenieure Vdi 4602”, *VDI Standard*, pp. 1–26, Apr, 2016.
- [10] B. L. Capehart, W. C. Turner, W. J. Kennedy, “Guide to Energy Management”, Lilburn, GA: *The Fairmont Press*, 7th ed. 2006, https://books.google.co.za/books?hl=en&lr=&id=8zA9ONTNgpIC&oi=fnd&pg=PA1&ots=YcJVT4IRhT&sig=_U_Z8-

- FPGBrYoIFzxaZB40OVVa4&redir_esc=y#v=onepage&q&f=false, ISBN-10: 0-88173-671-6 [Accessed February 23, 2019].
- [11] E. A. Abdelaziz, R. Saidur, S. Mekhilef, “A review on energy-saving strategies in industrial sector”, *Renewable and Sustainable Energy Reviews* vol. 15, no. 1, pp. 150–168, 2011. <https://doi.org/10.1016/j.rser.2010.09.003>.
- [12] S. A. Ates, N. M. Durakbasa, “Evaluation of corporate energy management practices of energy-intensive industries in Turkey”, *Energy*, Vol.45, no. 1, pp. 81–91, 2012. <https://doi.org/10.1016/j.energy.2012.03.032>.
- [13] B. Pascoe, “Improved control processes to sustain electricity cost savings on a mine water reticulation system”, M.Eng. thesis, North-West University, South Africa, 2018.
- [14] G. May, I. Barletta, B. Stahl, M. Taisch, “Energy management in production: A novel method to develop key performance indicators for improving energy efficiency”, *Applied Energy*, vol. 149, no.1, pp. 46–61, 2015. <https://doi.org/10.1016/j.apenergy.2015.03.065>.
- [15] H. M. J. Van Rensburg, “Structuring mining data for RSA Section 12L EE tax incentives”, M.Eng. thesis, North-West University, South Africa, 2015.
- [16] South African Bureau of Standards (SABS), “SANS 50001:2011 energy management systems: Requirements with guidance for use,” SABS Standards Division, Pretoria, 2011.
- [17] W. Hamer, “A practical approach to quantify RSA Section 12L EE tax incentives for large industry”, PhD.Eng. thesis, North-West University, South Africa, 2016.
- [18] A. Shiri, “Making sense of big data: A facet analysis approach”, *Knowledge Organization*, vol. 41, no.5, pp. 357–368, 2014 <http://www.scopus.com/inward/record.url?eid=2-s2.0-84913553153&partnerID=tZOtx3y1>.
- [19] P. Goosen, J. A. Swanepoel, J. N. Du Plessis, “The Need for a Comprehensive Energy Management Information System for Industries”, *South African Journal of Industrial Engineering*, vol. 27, no.3, pp. 1–11, 2016. <https://doi.org/10.7166/27-3-1626>.
- [20] L. A. West, T.J. Hess, “Metadata as a knowledge management tool: Supporting intelligent agent and end-user access to spatial data”, *Decision Support Systems*, vol.

- 32, no. 3, pp. 247–264, 2002. [https://doi.org/10.1016/S0167-9236\(01\)00102-6](https://doi.org/10.1016/S0167-9236(01)00102-6).
- [21] R. W. Rousseau, R. M. Felder, *Elementary Principle of Chemical Processes*, 3rd Ed., Danvers, MA: John Wiley, 2005.
- [22] R. Maneschijn, “Developing a dynamic operational energy management strategy for energy-intensive industries”, PhD.Eng. thesis, North-West University, South Africa, 2016.
- [23] T. Amundson, S. Brooks, J. Eskil, “Elements of Defensible Regression-Based Energy Models for Monitoring and Reporting Energy Savings in Industrial Energy Efficiency Operation and Maintenance Projects Process of Developing a Linear Regression Model”, In Proc. Conference on the *American Council for an Energy-Efficient Economy*, vol. 6, pp. 1–14, 2013.
- [24] Y. Zhang, S. Ma, H. Yang, J. Lv, Y. Liu, “A big data-driven analytical framework for energy-intensive manufacturing industries”, *Journal of Cleaner Production*, vol. 197, no.1, pp. 57–72, 2018. <https://doi.org/10.1016/j.jclepro.2018.06.170>.
- [25] M. Allen, D. Cervo, “Data quality management”, *Elsevier, Waltham*, pp. 1-219, 2015. <https://doi.org/10.1016/B978-0-12-800835-5.00009-9>.
- [26] G. E. Du Plessis, L. Liebenberg, E. H. Mathews, J. N. Du Plessis, “A versatile energy management system for large integrated cooling systems”, *Energy Conversion and Management*, vol. 66, no. 1, pp. 312–325, 2013. <https://doi.org/10.1016/j.enconman.2012.12.016>.
- [27] M. Pan, J. Sikorski, J. Akroyd, S. Mosbach, R. Lau, M. Kraft, “Design technologies for eco-industrial parks: From unit operations to processes, plants and industrial networks”, *Applied Energy*, vol. 175, no. 1, pp. 305–323, 2016. <https://doi.org/10.1016/j.apenergy.2016.05.019>.
- [28] K. Bunse, M. Vodicka, “Managing energy efficiency in manufacturing processes – implementing energy performance in production information technology systems”, In Proc. Conference on the *IFIP Advances in Information and Communication Technology*, vol. 328, pp. 260–268, 2010. https://doi.org/10.1007/978-3-642-15479-9_25.
- [29] A. García-Holgado, F. J. García-Peñalvo, Á. Hernández-García, F. Llorens-Largo, “New Information and Communication Technologies for Knowledge Management in

- Organizations”, In Proc. Conference on the *Global Innovation and Knowledge*, pp. 1-145, 2015. <https://doi.org/10.1007/978-3-319-22204-2>.
- [30] T. H. Davenport, D. W. De Long, M. C. Beers, “Successful Knowledge Management Projects”, *Sloan Management Review*, vol. 93, no. 5, pp. 487–493, 1998. <https://doi.org/10.1016/j.ygeno.2009.01.004>.
- [31] Earl M., “Knowledge Management Strategies: Toward a Taxonomy”, *Journal of Management Information Systems*, vol. 18, no. 1, pp. 215–233, 2001.
- [32] S. van Jaarsveld, “Developing an integrated information system to assess the operational condition of deep level mine equipment”, PhD.Eng. thesis, North-West University, South Africa, 2018. <https://doi.org/orcid.org/0000-0003-3270-6860>.
- [33] R. A. P. Fockema, “A customisable data analysis interface for an online electrical energy information system”, M.Eng. thesis, North-West University, South Africa, 2014.
- [34] Jardine One Solution (HK) Limited, “Disrupting Your 9 to 5”, www.jos.com, [Online], 2019. Available: <https://www.jos.com/solutions/future-workplace> (accessed June 1, 2019).
- [35] N. Chungoora, R. I. M. M. Young, “A Framework to Support Semantic Interoperability in Product Design and Manufacture”, *PhD.*, Loughborough University, United Kingdoms, 2011. <https://doi.org/10.1007/978-3-642-15973-2-44>.
- [36] B. Hjørland, “Facet analysis: The logical approach to knowledge organization”, *Information Processing and Management*, vol. 49, no. 2, pp. 545–557, 2013. <https://doi.org/10.1016/j.ipm.2012.10.001>.
- [37] R. Lambiotte, M. Ausloos, “Collaborative tagging as a tripartite network”, In Proc. Conference on *Computer Science*, vol. 3993, pp. 1114–1117, 2006. https://doi.org/10.1007/11758532_152.
- [38] E. D. Feigelson, Ž. Ivezić, J. Hilbe, K. D. Borne, “New Organizations to Support Astrominformatics and Astrostatistics”, www.cornell.edu, 2013. [Online] Available: <http://arxiv.org/abs/1301.3069> [Accessed: March 31, 2019].
- [39] B. D. Lund, D. A. Agbaji, “What Scheme Do We Prefer? An examination of preference between library of congress and dewey decimal classification among U.S.-Based Academic Library Employees”, *Knowledge Organization*, vol. 45, no.5, pp. 380–392,

2018. <https://doi.org/10.5771/0943-7444-2018-5-380>.
- [40] B. Haslhofer, W. Klas, “A survey of techniques for achieving metadata interoperability”, *ACM Computing Surveys*, vol. 42, no. 2, pp. 1–37, 2010. <https://doi.org/10.1145/1667062.1667064>.
- [41] N. Islam, “S. R . Ranganathan: library and documentation scientist”, *Current Science Association*, vol. 108, no. 11, pp. 2110–2112, 2015.
- [42] U. Priss, “Facet-like structures in computer science”, *Axiomathes*, vol. 18, no. 2, pp. 243–255, 2008. <https://doi.org/10.1007/s10516-007-9023-y>.
- [43] J. Zaytoon, “Specification and design of logic controllers for automated manufacturing systems”, *Robotics and Computer-Integrated Manufacturing*, vol. 12, no. 4, pp. 353–366, 1996. [https://doi.org/10.1016/S0736-5845\(96\)00015-4](https://doi.org/10.1016/S0736-5845(96)00015-4).
- [44] M. A. Gopinath, “Ranganathan’s Theory of Fact Analysis and Knowledge Representation”, *DESIDOC Bulletin of Information Technology*, vol. 12, no. 5, pp. 16–20, 2014. <https://doi.org/10.14429/dbit.12.5.3064>.
- [45] T. Teorey, S. Lightstone, T. Nadeau, H. V. Jagadish, “Database modelling and design: Logical Design”, 5th ed., Burlington, MA, 2011.
- [46] J. Celko, E.E. Ian Robinson, Jim Webber, J. Celko, “Graph Databases”, *O’Reilly Media*, pp. 27-46, 2014. <https://doi.org/10.1016/B978-0-12-407192-6.00003-0>.
- [47] P. Mohammed, P. Mohan, “Contextualizing learning objects using ontologies, Computational Intelligence”, vol. 23, no. 3, 339–355, 2007. <https://doi.org/10.1111/j.1467-8640.2007.00309.x>.
- [48] C. Oosthuizen, “A compressed air cost savings identification model for deep-level mines”, M.Eng. thesis, North-West University, South Africa, 2018.
- [49] P. Maré, J. H. Marais, J. Van Rensburg, “Improved implementation strategies to sustain energy-saving measures on mine cooling systems”, In Proc. Conference on the Industrial and Commercial Use of Energy, ICUE, September 2015, pp. 102–109. <https://doi.org/10.1109/ICUE.2015.7280254>.
- [50] J. L. Buys, M. Kleingeld, C. Cilliers, “Optimising the refrigeration and cooling system of a platinum mine”, In Proc. Conference on the Industrial and Commercial Use of Energy, ICUE, 2015, pp. 36–43. <https://doi.org/10.1109/ICUE.2015.7280244>.

- [51] R. C. Hochreiter, D. C. Kennedy, W. Muir, A. I. Wood, “Platinum in South Africa”, *Journal of the South African Institute of Mining and Metallurgy*, vol. 85, no. 6, pp. 165–185, 1985.
- [52] J. Feng, V. Patel, S. Dasgupta, P. Ramdoss, J. Wu, “Application of dynamic simulation in the design, operation, and troubleshooting of compressor systems”, In Proc. 36th Turbomachinery Symposium, 2007, pp. 95–106.
- [53] Eskom, “Eskom Tariffs & Charges Booklet 2019/2020”, *eskom.co.za*, pp. 1-48, 2019. [Online] Available: <http://www.eskom.co.za/CustomerCare/TariffsAndCharges/Documents/Complete%20Tariff%202019%20web1.pdf> [Accessed: 1 April 2019]
- [54] K. M. Osei-Bryson, “A context-aware data mining process model-based framework for supporting evaluation of data mining results”, *Expert Systems with Applications*, vol. 39, no. 1, pp. 1156–1164, 2012. <https://doi.org/10.1016/j.eswa.2011.07.117>.
- [55] Z. Usman, R. I. M. Young, N. Chungoora, C. Palmer, K. Case, J. A. Harding, “Towards a formal manufacturing reference ontology”, *International Journal of Production Research*, vol. 51, no. 22, pp. 6553–6572, 2013. <https://doi.org/10.1080/00207543.2013.801570>.

APPENDIX A: PLATINUM MINE A CASE STUDY

A.1.1 Various energy management dashboards

The data structure aids access to the data, but in addition to being able to define and manage the data through the data structure, the data must also be visualised. The data structure allows various visualisations to be implemented. This results in various dashboards, which can be used for varying observations.

Figure 39 shows that frequency graphs can be built with the data model.

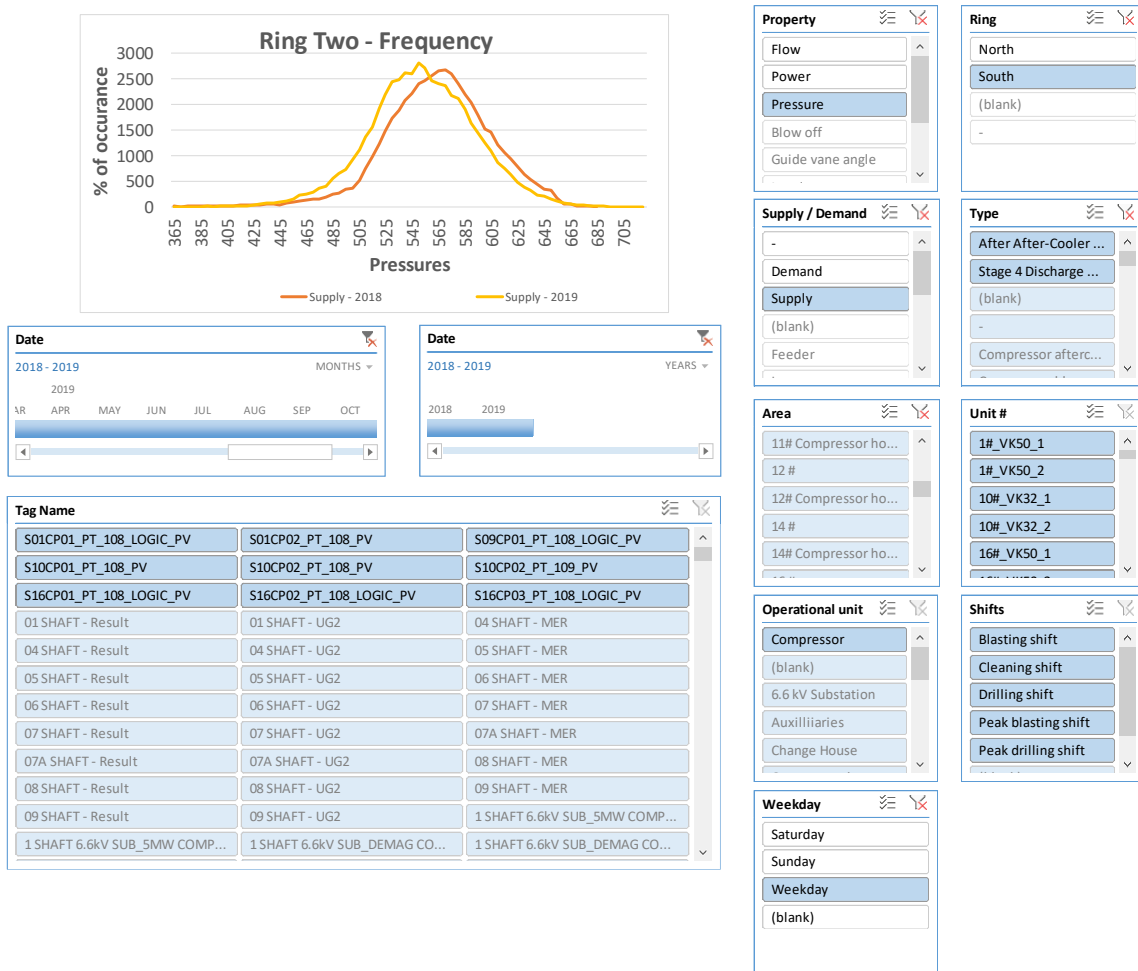

Figure 39: Frequency dashboard

The frequency dashboard can be used to analyse the pressure reduction initiatives for the rings, shaft, times and days required. The data structure had to be amended slightly by adding a non-related table to define the bins of the frequency chart on the x-axis.

Figure 40 shows the distribution of various boundary levels, as defined in the data structure.

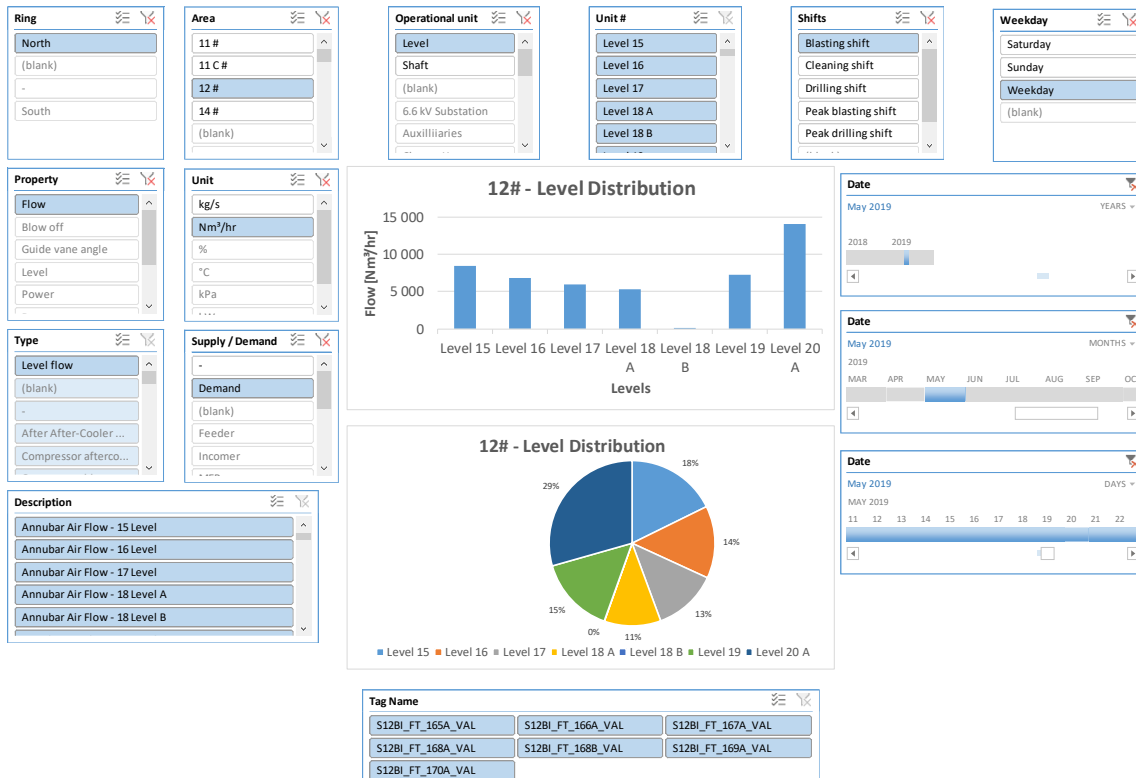

Figure 40: Distribution dashboard

The distribution of 12 Shaft’s Levels is shown using the knowledge captured in the data structure. No changes were required to be made to the data structure; only the Excel pivot chart⁹ had to be modified.

Figure 41 shows that various calculations, based on filters of the fields, can be added and used to visualise the data.

⁹Microsoft, Create a Pivot Table to analyze worksheet data, (accessed 2019/09/30): <https://support.office.com/en-us/article/create-a-pivottable-to-analyze-worksheet-data-a9a84538-bfe9-40a9-a8e9-f99134456576>

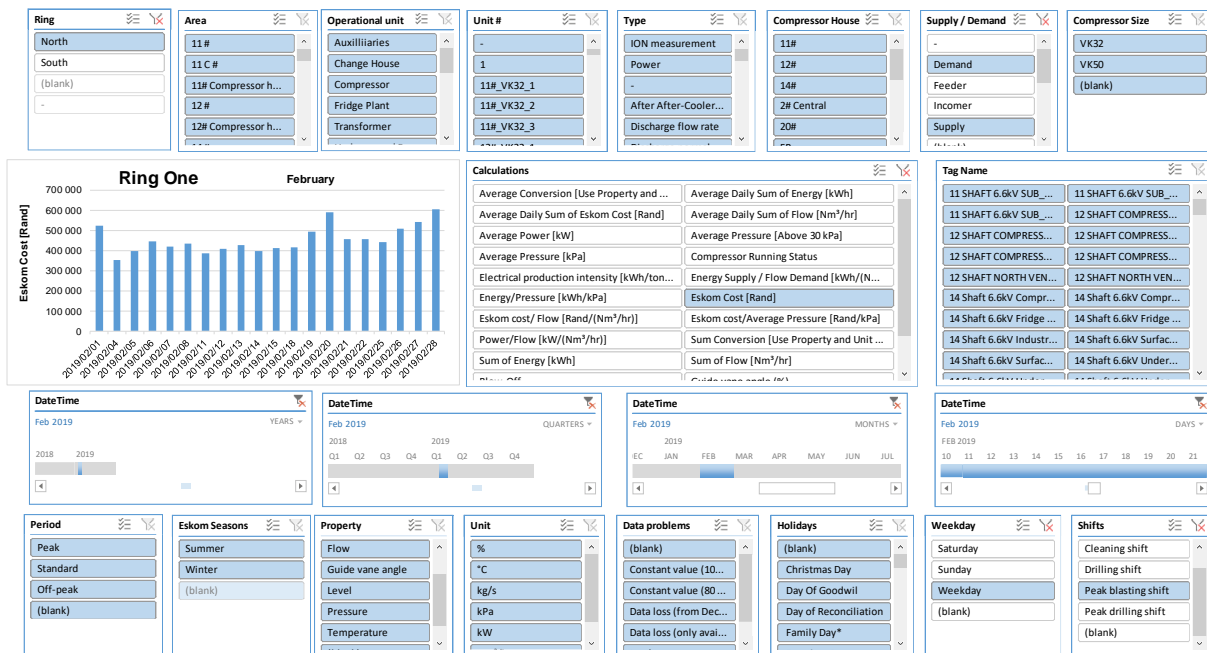

Figure 41: Calculation Dashboard

The daily cost for Ring One’s Compressed air for February 2019 can be seen in the dashboard above. Simple calculations as summarised in Table 10 were calculated using measures¹⁰ and DAX calculations⁴. These calculations were then visualised in the visualisation dashboard, using the same data structure as before. An unrelated table (Table 10) was used to select the required calculations.

Table 10: DAX calculations

Calculations	Index
Average Conversion [Use Property and Unit Slicer]	1
Power/Flow [kW/(Nm³/hr)]	2
Energy/Pressure [kWh/kPa]	3
Sum Conversion [Use Property and Unit Slicer]	4
Eskom Cost [Rand]	5
Eskom cost/Average Pressure [Rand/kPa]	6
Eskom cost/ Flow [Rand/(Nm³/hr)]	7
Average Pressure [Above 30 kPa]	8
Average Pressure [kPa]	9
Sum of Flow [Nm³/hr]	10
Sum of Energy [kWh]	11
Average Power [kW]	12
Average Daily Sum of Flow [Nm³/hr]	13
Average Daily Sum of Energy [kWh]	14
Average Daily Sum of Eskom Cost [Rand]	15
Energy Supply / Flow Demand [kWh/(Nm³/hr)]	16
Compressor Running Status	17
Guide vane angle (%)	18
Blow-Off	19
Production [Tonnes]	20

¹⁰ Microsoft, Measures in Power Pivot, (accessed 2019/09/30): <https://support.office.com/en-us/article/measures-in-power-pivot-86484821-a324-4da3-803b-82fd2e5033f4>

Calculations	Index
Electrical production intensity [kWh/tonnes]	21

A.1.2 Energy reticulation information table

Table 11 captures the reticulation understanding of the compressed air for Platinum Mine A. This is a large table, but the size of the table motivates why there is a need for this study.

Table 11: Platinum mine A - Compressed air reticulation captured

Tag Name	Description	Type	Supply / Demand	Property	Operational unit	Unit #	Area	Ring	Data Source
10 SHAFT COMPRESSOR SUB_COMPRESSOR AUX TRFR1 (kW Imp)	Auxiliaries	Power	Supply	Power	Auxiliaries	-	10# Compressor house	Two	IST/ASTIR
10 SHAFT COMPRESSOR SUB_COMPRESSOR AUX TRFR2 (kW Imp)	Auxiliaries	Power	Supply	Power	Auxiliaries	-	10# Compressor house	Two	IST/ASTIR
12 SHAFT COMPRESSOR SUB_COMPRESSOR1 AUX TRFR (kW Imp)	Auxiliaries	Power	Supply	Power	Auxiliaries	-	12# Compressor house	One	IST/ASTIR
S01CP02_FT_110_PV	Annubar Air Flow - Bank	-	Demand	Flow	Shaft	1 #	1 #	Two	ASPEN
12 SHAFT COMPRESSOR SUB_COMPRESSOR2 AUX TRFR (kW Imp)	Auxiliaries	Power	Supply	Power	Auxiliaries	-	12# Compressor house	One	IST/ASTIR
9 SHAFT COMPRESSOR SUB_COMPRESSOR AUX TRFR (kW Imp)	Auxiliaries	Power	Supply	Power	Auxiliaries	-	9# Compressor house	Two	IST/ASTIR
CENTRAL COMPRESSOR SUB_AUXILLIARY TRANSFORMER (kW Imp)	Auxiliaries	Power	Supply	Power	Auxiliaries	-	Central compressor house	One	IST/ASTIR
S01CP01_FNT_109_LOGIC_PV	Comp Disch Normal Flow	Discharge normal flow rate	Supply	Flow	Compressor	1#_VK50_1	1# Compressor house	Two	ASPEN
S01CP02_PT_110_PV	Common Header Pressure	Shaft supply pressure	Demand	Pressure	Shaft	1 #	1 #	Two	ASPEN
S01CP02_PT_109_LOGIC_PV	Compressor Discharge Pressure	After After-Cooler Pressure	-	Pressure	Compressor	1#_VK50_2	1# Compressor house	Two	ASPEN
S01CP02_FNT_109_PV	Comp Disch Normal Flow	Discharge normal flow rate	-	Flow	Compressor	1#_VK50_2	1# Compressor house	Two	ASPEN

Tag Name	Description	Type	Supply / Demand	Property	Operational unit	Unit #	Area	Ring	Data Source
S01CP02_PT_109_PV	Compressor Discharge Pressure	After After-Cooler Pressure	-	Pressure	Compressor	1#_VK50_2	1# Compressor house	Two	ASPEN
S10CP01_PT_109_LOGIC_PV	After After-Cooler Pressure	After After-Cooler Pressure	-	Pressure	Compressor	10#_VK32_1	10# Compressor house	Two	ASPEN
S10CP02_PT_109_PV	After After-cooler Discharge Pre	After After-Cooler Pressure	Supply	Pressure	Compressor	10#_VK32_2	10# Compressor house	Two	ASPEN
S11CP01_PT_109_PV	After After-cooler Discharge Pre	After After-Cooler Pressure	Supply	Pressure	Compressor	11#_VK32_1	11# Compressor house	One	ASPEN
S02CP01_FNT_109_LOGIC_PV	Comp Disch Normal Flow	Discharge normal flow rate	-	Flow	Compressor	Cen#_VK32_1	Central compressor house	One	ASPEN
S02CP01_FT_109_LOGIC_PV	Central CP01 Discharge flow rate	Discharge flow rate	Supply	Flow	Compressor	Cen#_VK32_1	Central compressor house	One	ASPEN
S11CP02_PT_109_PV	After After-cooler Discharge Pre	After After-Cooler Pressure	Supply	Pressure	Compressor	11#_VK32_2	11# Compressor house	One	ASPEN
S11CP03_PT_109_PV	After After-cooler Pressure	After After-cooler Pressure	Supply	Pressure	Compressor	11#_VK32_3	11# Compressor house	One	ASPEN
S02CP01_TT_108_LOGIC_PV	Central CP01 Discharge temp	Compressor discharge temperature	-	Temperature	Compressor	Cen#_VK32_1	Central compressor house	One	ASPEN
S02CP01_TT_109_LOGIC_PV	Central CP01 After aftercooler temp	Compressor aftercooler temp	-	Temperature	Compressor	Cen#_VK32_1	Central compressor house	One	ASPEN
S02CP01_ZT_101_LOGIC_PV	Central CP01 Guide vane angle	Compressor guide vane angle	-	Status	Compressor	Cen#_VK32_1	Central compressor house	One	ASPEN
S02CP01_ZT_109_LOGIC_PV	Central CP01 Blow off position	Compressor blow-off position	-	Status	Compressor	Cen#_VK32_1	Central compressor house	One	ASPEN
S02CP02_FNT_109_LOGIC_PV	Comp Disch Normal Flow	Discharge normal flow rate	-	Flow	Compressor	Cen#_VK32_2	Central compressor house	One	ASPEN

Tag Name	Description	Type	Supply / Demand	Property	Operational unit	Unit #	Area	Ring	Data Source
S02CP02_FT_109_LOGIC_PV	Central CP02 Discharge flow rate	Discharge flow rate	Supply	Flow	Compressor	Cen#_VK32_2	Central compressor house	One	ASPEN
S12CP01_PT_109_LOGIC_PV	After After-Cooler Pressure	After After-Cooler Pressure	-	Pressure	Compressor	12#_VK32_1	12# Compressor house	One	ASPEN
S12CP02_PT_109_LOGIC_PV		After After-Cooler Pressure	-	Pressure	Compressor	12#_VK32_2	12# Compressor house	One	ASPEN
S02CP02_TT_108_LOGIC_PV	Central CP02 Discharge temp	Compressor discharge temperature	-	Temperature	Compressor	Cen#_VK32_2	Central compressor house	One	ASPEN
S02CP02_TT_109_LOGIC_PV	Central CP02 After aftercooler temp	Compressor aftercooler temp	-	Temperature	Compressor	Cen#_VK32_2	Central compressor house	One	ASPEN
S02CP02_ZT_101_LOGIC_PV	Central CP02 Guide vane angle	Compressor guide vane angle	-	Status	Compressor	Cen#_VK32_2	Central compressor house	One	ASPEN
S02CP02_ZT_109_LOGIC_PV	Central CP02 Blow off position	Compressor blow-off position	-	Status	Compressor	Cen#_VK32_2	Central compressor house	One	ASPEN
S02CP03_FNT_109_LOGIC_PV	Comp Disch Normal Flow	Discharge normal flow rate	-	Flow	Compressor	Cen#_VK32_3	Central compressor house	One	ASPEN
S02CP03_FT_109_LOGIC_PV	Central CP03 Discharge flow rate	Discharge flow rate	Supply	Flow	Compressor	Cen#_VK32_3	Central compressor house	One	ASPEN
S12CP03_PT_109_LOGIC_PV		After After-Cooler Pressure	-	Pressure	Compressor	12#_VK50_3	12# Compressor house	One	ASPEN
S14CP01_PT_109_LOGIC_PV	After after-cooler discharge pressure	After After-Cooler Pressure	Supply	Pressure	Compressor	14#_VK50_1	14# Compressor house	One	ASPEN
S02CP03_TT_108_LOGIC_PV	Central CP03 Discharge temp	Compressor discharge temperature	-	Temperature	Compressor	Cen#_VK32_3	Central compressor house	One	ASPEN
S02CP03_TT_109_LOGIC_PV	Central CP03 After aftercooler temp	Compressor aftercooler temp	-	Temperature	Compressor	Cen#_VK32_3	Central compressor house	One	ASPEN

Tag Name	Description	Type	Supply / Demand	Property	Operational unit	Unit #	Area	Ring	Data Source
S02CP03_ZT_101_LOGIC_PV	Central CP03 Guide vane angle	Compressor guide vane angle	-	Status	Compressor	Cen#_VK 32_3	Central compressor house	One	ASPEN
S02CP03_ZT_109_LOGIC_PV	Central CP03 Blow off position	Compressor blow-off position	-	Status	Compressor	Cen#_VK 32_3	Central compressor house	One	ASPEN
S02CP04_FNT_109_LOGIC_PV	Comp Disch Normal Flow	Discharge normal flow rate	-	Flow	Compressor	Cen#_VK 50_4	Central compressor house	One	ASPEN
S02CP04_FT_109_PV	Central CP04 Discharge flow rate	Discharge flow rate	Supply	Flow	Compressor	Cen#_VK 50_4	Central compressor house	One	ASPEN
S14CP02_PT_109_LOGIC_PV	After after-cooler discharge pressure	After After-Cooler Pressure	Supply	Pressure	Compressor	14#_VK50_2	14# Compressor house	One	ASPEN
S16CP01_PT_109_LOGIC_PV	After After-Cooler Pressure	After After-Cooler Pressure	-	Pressure	Compressor	16#_VK50_1	16# Compressor house	Two	ASPEN
S02CP04_TT_108_LOGIC_PV	Central CP04 Discharge temp	Compressor discharge temperature	-	Temperature	Compressor	Cen#_VK 50_4	Central compressor house	One	ASPEN
S02CP04_TT_109_LOGIC_PV	Central CP04 After aftercooler temp	Compressor aftercooler temp	-	Temperature	Compressor	Cen#_VK 50_4	Central compressor house	One	ASPEN
S02CP04_ZT_101_LOGIC_PV	Central CP04 Guide vane angle	Compressor guide vane angle	-	Status	Compressor	Cen#_VK 50_4	Central compressor house	One	ASPEN
S02CP04_ZT_109_LOGIC_PV	Central CP04 Blow off position	Compressor blow-off position	-	Status	Compressor	Cen#_VK 50_4	Central compressor house	One	ASPEN
S02SCP01_FNT_109_LOGIC_PV	Comp Disch Normal Flow	Discharge normal flow rate	Supply	Flow	Compressor	2#_VK32_1	2# Compressor house	Two	ASPEN
S16CP02_PT_109_LOGIC_PV	After After-Cooler Pressure	After After-Cooler Pressure	-	Pressure	Compressor	16#_VK50_2	16# Compressor house	Two	ASPEN
S16CP03_PT_109_LOGIC_PV	After After-Cooler Pressure	After After-Cooler Pressure	-	Pressure	Compressor	16#_VK50_3	16# Compressor house	Two	ASPEN
S04BI_FT_161A_VAL	S4 Flow demand	-	Demand	Flow	Shaft	4 #	4 #	One	ASPEN

Tag Name	Description	Type	Supply / Demand	Property	Operational unit	Unit #	Area	Ring	Data Source
U01L10_PT_161A_LOGIC_PV	Annubar Air Pressure - 10 Level	Level Pressure	Demand	Pressure	Level	Level 10	1 #	Two	ASPEN
S04BI_TT_161A_VAL	S4 Temp demand	Shaft temperature	Demand	Temperature	Shaft	4 #	4 #	One	ASPEN
S06BI_FT_161A_VAL	Annubar Air Flow - Bank	Shaft flow	Demand	Flow	Shaft	6 #	6 #	One	ASPEN
U01L10_PT_161B_LOGIC_PV	Compressed Air Pressure - 10 Lev	Level Pressure	Demand	Pressure	Level	Level 10	1 #	Two	ASPEN
S06BI_TT_161A_VAL	S6 Temp demand	Shaft temperature	Demand	Temperature	Shaft	6 #	6 #	One	ASPEN
S02SCP02_FNT_109_LOGIC_PV	Comp Disch Normal Flow	Discharge normal flow rate	Supply	Flow	Compressor	2#_VK32_2	2# Compressor house	Two	ASPEN
S02SCP01_PT_109_LOGIC_PV	After After-Cooler Pressure	After After-Cooler Pressure	Supply	Pressure	Compressor	2#_VK32_1	2# Compressor house	Two	ASPEN
S02SCP02_PT_109_LOGIC_PV	After After-Cooler Pressure	After After-Cooler Pressure	Supply	Pressure	Compressor	2#_VK32_2	2# Compressor house	Two	ASPEN
S20CP01_PT_109_LOGIC_PV	After-cooler discharge pressure	After After-Cooler Pressure	Supply	Pressure	Compressor	20#_VK32_1	20# Compressor house	One	ASPEN
S07CP01_ZT_109_LOGIC_PV		Compressor blow-off position	-	Status	Compressor	7#_VK32_1	7# Compressor house	One	ASPEN
S20CP02_PT_109_LOGIC_PV	After-cooler discharge pressure	After After-Cooler Pressure	Supply	Pressure	Compressor	20#_VK32_2	20# Compressor house	One	ASPEN
S07CP02_ZT_101_LOGIC_PV		Compressor guide vane angle	-	Status	Compressor	7#_VK32_2	7# Compressor house	One	ASPEN
S07CP02_ZT_109_LOGIC_PV		Compressor blow-off position	-	Status	Compressor	7#_VK32_2	7# Compressor house	One	ASPEN
S09BI_FT_161A_VAL	Annubar Air Flow - Bank	Shaft flow	Demand	Flow	Shaft	9 #	9 #	Two	ASPEN
S10BI_PT_401_VAL	Bank Air Pressure	Shaft supply pressure	Demand	Pressure	Shaft	10 #	10 #	Two	ASPEN
S11CV01_PT_161A_LOGIC_PV	Compressed Air Supply Pressure	Shaft supply pressure	Demand	Pressure	Shaft	11 #	11 #	One	ASPEN

Tag Name	Description	Type	Supply / Demand	Property	Operational unit	Unit #	Area	Ring	Data Source
S20CP03_PT_109_LOGIC_PV	After after-cooler discharge pressure	After After-Cooler Pressure	Supply	Pressure	Compressor	20#_VK32_3	20# Compressor house	One	ASPEN
S07CP03_ZT_101_LOGIC_PV		Compressor guide vane angle	-	Status	Compressor	7#_VK32_3	7# Compressor house	One	ASPEN
S07CP03_ZT_109_LOGIC_PV		Compressor blow-off position	-	Status	Compressor	7#_VK32_3	7# Compressor house	One	ASPEN
S09CP01_FNT_109_LOGIC_PV	Compressor Discharge Normal Volu	Discharge normal flow rate	Supply	Flow	Compressor	9#_VK32_1	9# Compressor house	Two	ASPEN
S09CP01_FNT_109_PV	Compressor Discharge Normal Volu	Discharge normal flow rate	-	Flow	Compressor	9#_VK32_1	9# Compressor house	Two	ASPEN
S09CP01_PT_109_LOGIC_PV		After After-Cooler Pressure	-	Pressure	Compressor	9#_VK32_1	9# Compressor house	Two	ASPEN
U11CVC4_PT_161C_LOGIC_PV	19L Compressed Air Pressure	Level Pressure	Demand	Pressure	Level	11 #	11 #	One	ASPEN
S09CP01_PT_109_PV		After After-Cooler Pressure	-	Pressure	Compressor	9#_VK32_1	9# Compressor house	Two	ASPEN
S02CP01_PT_109_LOGIC_PV	After After-Cooler Pressure	After After-Cooler Pressure	-	Pressure	Compressor	Cen#_VK32_1	Central compressor house	One	ASPEN
S02CP02_PT_109_LOGIC_PV	After After-Cooler Pressure	After After-Cooler Pressure	-	Pressure	Compressor	Cen#_VK32_2	Central compressor house	One	ASPEN
S10CP01_FNT_109_PV	Comp Disch Normal Flow	Discharge normal flow rate	-	Flow	Compressor	10#_VK32_1	10# Compressor house	Two	ASPEN
S02CP03_PT_109_LOGIC_PV	After After-Cooler Pressure	After After-Cooler Pressure	-	Pressure	Compressor	Cen#_VK32_3	Central compressor house	One	ASPEN
S02CP04_PT_109_PV	After After-cooler Pressure	After After-Cooler Pressure	Supply	Pressure	Compressor	Cen#_VK50_4	Central compressor house	One	ASPEN
S10CP02_FT_161A_PV	Annubar Air Flow A - Bank	-	Demand	Flow	Shaft	10 #	10 #	Two	ASPEN

Tag Name	Description	Type	Supply / Demand	Property	Operational unit	Unit #	Area	Ring	Data Source
S10CP02_FT_161B_PV	Annubar Air Flow B - Bank	-	Demand	Flow	Shaft	10 #	10 #	Two	ASPEN
S10CP02_FT_161C_PV	Annubar Air Flow C - Bank	-	Demand	Flow	Shaft	10 #	10 #	Two	ASPEN
S16CP01_PT_109_PV		After After-Cooler Pressure	Demand	Pressure	Shaft	16 #	16 #	Two	ASPEN
S02SCP01_PT_110_LOGIC_PV	Compressor Discharge Pressure	Compressor Discharge Pressure	-	Pressure	Compressor	2#_VK32_1	2# Compressor house	Two	ASPEN
S02SCP02_PT_110_LOGIC_PV	Compressor Discharge Pressure	Compressor Discharge Pressure	-	Pressure	Compressor	2#_VK32_2	2# Compressor house	Two	ASPEN
S10CP02_FNT_109_PV	Cmp Disch Normal Volumetric Flow	Discharge normal flow rate	-	Flow	Compressor	10#_VK32_2	10# Compressor house	Two	ASPEN
S11CP01_FNT_109_PV	Compressor Disch Normal Volumetr	Discharge normal flow rate	-	Flow	Compressor	11#_VK32_1	11# Compressor house	One	ASPEN
S11CP01_FT_109_PV	S11 CP01 Discharge flow rate	Discharge flow rate	Supply	Flow	Compressor	11#_VK32_1	11# Compressor house	One	ASPEN
S02CP04_PT_108_PV		Stage 4 Discharge Pressure	-	Pressure	Compressor	Cen#_VK50_4	Central compressor house	One	ASPEN
S11CP01_PT_108_PV		Stage 4 Discharge Pressure	Supply	Pressure	Compressor	11#_VK32_1	11# Compressor house	One	ASPEN
S11CP01_TT_108_LOGIC_PV	S11 CP01 Discharge temp	Compressor discharge temperature	-	Temperature	Compressor	11#_VK32_1	11# Compressor house	One	ASPEN
S11CP01_TT_109_LOGIC_PV	S11 CP01 After aftercooler temp	Compressor aftercooler temp	-	Temperature	Compressor	11#_VK32_1	11# Compressor house	One	ASPEN
S11CP01_ZT_101_LOGIC_PV	S11 CP01 Guide vane angle	Compressor guide vane angle	-	Status	Compressor	11#_VK32_1	11# Compressor house	One	ASPEN
S11CP01_ZT_109_LOGIC_PV	S11 CP01 Blow off position	Compressor blow-off position	-	Status	Compressor	11#_VK32_1	11# Compressor house	One	ASPEN

Tag Name	Description	Type	Supply / Demand	Property	Operational unit	Unit #	Area	Ring	Data Source
S11CP02_FNT_109_PV	Compressor Disch Normal Volumetr	Discharge normal flow rate	-	Flow	Compressor	11#_VK32_2	11# Compressor house	One	ASPEN
S11CP02_FT_109_PV	S11 CP02 Discharge flow rate	Discharge flow rate	Supply	Flow	Compressor	11#_VK32_2	11# Compressor house	One	ASPEN
S11CP02_PT_108_PV		Stage 4 Discharge Pressure	Supply	Pressure	Compressor	11#_VK32_2	11# Compressor house	One	ASPEN
S11CP03_PT_108_PV		Stage 4 Discharge Pressure	Supply	Pressure	Compressor	11#_VK32_3	11# Compressor house	One	ASPEN
S11CP02_TT_108_LOGIC_PV	S11 CP02 Discharge temp	Compressor discharge temperature	-	Temperature	Compressor	11#_VK32_2	11# Compressor house	One	ASPEN
S11CP02_TT_109_LOGIC_PV	S11 CP02 After aftercooler temp	Compressor aftercooler temp	-	Temperature	Compressor	11#_VK32_2	11# Compressor house	One	ASPEN
S11CP02_ZT_101_LOGIC_PV	S11 CP02 Guide vane angle	Compressor guide vane angle	-	Status	Compressor	11#_VK32_2	11# Compressor house	One	ASPEN
S11CP02_ZT_109_LOGIC_PV	S11 CP02 Blow off position	Compressor blow-off position	-	Status	Compressor	11#_VK32_2	11# Compressor house	One	ASPEN
S11CP03_FNT_109_PV	Cmp Disch Normal Volumetric Flow	Discharge normal flow rate	-	Flow	Compressor	11#_VK32_3	11# Compressor house	One	ASPEN
S11CP03_FT_109_PV	S11 CP03 Discharge flow rate	Discharge flow rate	Supply	Flow	Compressor	11#_VK32_3	11# Compressor house	One	ASPEN
S10CP02_PT_108_PV		Stage 4 Discharge Pressure	Supply	Pressure	Compressor	10#_VK32_2	10# Compressor house	Two	ASPEN
S16CP01_PT_108_PV		Stage 4 Discharge Pressure	-	Pressure	Compressor	16#_VK50_1	16# Compressor house	Two	ASPEN
S11CP03_TT_108_LOGIC_PV	S11 CP03 Discharge temp	Compressor discharge temperature	-	Temperature	Compressor	11#_VK32_3	11# Compressor house	One	ASPEN
S11CV01_FT_161A_LOGIC_PV	S11 Flow demand	Shaft flow	Demand	Flow	Shaft	11 #	11 #	One	ASPEN
S11CCH01_PT_001_LOGIC_PV		Shaft supply pressure	Demand	Pressure	Shaft	11 C #	11 C #	One	ASPEN

Tag Name	Description	Type	Supply / Demand	Property	Operational unit	Unit #	Area	Ring	Data Source
S11CV01_TT_161A_LOGIC_PV	S11 Temp demand	Shaft temperature	Demand	Temperature	Shaft	11 #	11 #	One	ASPEN
S12BI_FT_161V_VAL	Combined Compressed Air Flow	Shaft flow	-	Flow	Shaft	12 #	12 #	One	ASPEN
S12BI_FT_165A_VAL	Annubar Air Flow - 15 Level	Level flow	Demand	Flow	Level	Level 15	12 #	One	ASPEN
S12BI_FT_166A_VAL	Annubar Air Flow - 16 Level	Level flow	Demand	Flow	Level	Level 16	12 #	One	ASPEN
S12BI_FT_167A_VAL	Annubar Air Flow - 17 Level	Level flow	Demand	Flow	Level	Level 17	12 #	One	ASPEN
S12BI_FT_168A_VAL	Annubar Air Flow - 18 Level A	Level flow	Demand	Flow	Level	Level 18 A	12 #	One	ASPEN
S12BI_FT_168B_VAL	Annubar Air Flow - 18 Level B	Level flow	Demand	Flow	Level	Level 18 B	12 #	One	ASPEN
S12BI_FT_169A_VAL	Annubar Air Flow - 19 Level	Level flow	Demand	Flow	Level	Level 19	12 #	One	ASPEN
S12BI_FT_170A_VAL	Annubar Air Flow - 20 Level A	Level flow	Demand	Flow	Level	Level 20 A	12 #	One	ASPEN
S12BI_FT_170B_VAL	Annubar Air Flow - 20 Level B	Level flow	-	Flow	Level	-	12 #	One	ASPEN
S12BI_FT_201_VAL	Underground Air Flow	Level flow	-	Flow	Level	-	12 #	One	ASPEN
S12BI_PT_165A_VAL	Annubar Air Pressure - 15 Level	Level Pressure	Demand	Pressure	Level	Level 15	12 #	One	ASPEN
S12BI_PT_166A_VAL	Annubar Air Pressure - 16 Level	Level Pressure	Demand	Pressure	Level	Level 16	12 #	One	ASPEN
S12BI_PT_167A_VAL	Annubar Air Pressure - 17 Level	Level Pressure	Demand	Pressure	Level	Level 17	12 #	One	ASPEN
S12BI_PT_168A_VAL	Annubar Air Pressure - 18 Level	Level Pressure	Demand	Pressure	Level	Level 18 A	12 #	One	ASPEN
S12BI_PT_168B_VAL	Annubar Air Pressure - 18 Level	Level Pressure	Demand	Pressure	Level	Level 18 B	12 #	One	ASPEN
S12BI_PT_169A_VAL	Annubar Air Pressure - 19 Level	Level Pressure	Demand	Pressure	Level	Level 19	12 #	One	ASPEN
S12BI_PT_170A_VAL	Annubar Air Pressure - 20 Level	Level Pressure	Demand	Pressure	Level	Level 20	12 #	One	ASPEN
S12BI_PT_201_VAL	Underground Air Pressure	Level Pressure	-	Pressure	Level	-	12 #	One	ASPEN

Tag Name	Description	Type	Supply / Demand	Property	Operational unit	Unit #	Area	Ring	Data Source
S12BI_TT_165A_VAL	Annubar Air Temperature - 15 Lev	Level air temperature	Demand	Temperature	Level	Level 15	12 #	One	ASPEN
S12BI_TT_166A_VAL	Annubar Air Temperature - 16 Lev	Level air temperature	Demand	Temperature	Level	Level 16	12 #	One	ASPEN
S12BI_TT_167A_VAL	Annubar Air Temperature - 17 Lev	Level air temperature	Demand	Temperature	Level	Level 17	12 #	One	ASPEN
S12BI_TT_168A_VAL	Annubar Air Temperature - 18 Lev	Level air temperature	Demand	Temperature	Level	Level 18 A	12 #	One	ASPEN
S12BI_TT_168B_VAL	Annubar Air Temperature - 18 Lev	Level air temperature	Demand	Temperature	Level	Level 18 B	12 #	One	ASPEN
S12BI_TT_169A_VAL	Annubar Air Temperature - 19 Lev	Level air temperature	Demand	Temperature	Level	Level 19	12 #	One	ASPEN
S12BI_TT_170A_VAL	Annubar Air Temperature - 20 Lev	Level air temperature	Demand	Temperature	Level	Level 20	12 #	One	ASPEN
S11CP03_TT_109_LOGIC_PV	S11 CP03 After aftercooler temp	Compressor aftercooler temp	-	Temperature	Compressor	11#_VK32_3	11# Compressor house	One	ASPEN
S11CP03_ZT_101_LOGIC_PV	S11 CP03 Guide vane angle	Compressor guide vane angle	-	Status	Compressor	11#_VK32_3	11# Compressor house	One	ASPEN
S11CP03_ZT_109_LOGIC_PV	S11 CP03 Blow off position	Compressor blow-off position	-	Status	Compressor	11#_VK32_3	11# Compressor house	One	ASPEN
S12CP01_FNT_109_LOGIC_PV	Comp Disch Normal Flow	Discharge normal flow rate	-	Flow	Compressor	12#_VK32_1	12# Compressor house	One	ASPEN
S12CP01_PT_110_LOGIC_PV	Shaft Header Pressure	Shaft supply pressure	Demand	Pressure	Shaft	12 #	12 #	One	ASPEN
S12CP01_FT_109_LOGIC_PV	S12 CP01 Discharge flow rate	Discharge flow rate	Supply	Flow	Compressor	12#_VK32_1	12# Compressor house	One	ASPEN
S16CP02_PT_108_PV		Stage 4 Discharge Pressure	-	Pressure	Compressor	16#_VK50_2	16# Compressor house	Two	ASPEN

Tag Name	Description	Type	Supply / Demand	Property	Operational unit	Unit #	Area	Ring	Data Source
S16CP03_PT_108_PV		Stage 4 Discharge Pressure	-	Pressure	Compressor	16#_VK50_3	16# Compressor house	Two	ASPEN
S12CP01_TT_108_LOGIC_PV	S12 CP01 Discharge temp	Compressor discharge temperature	-	Temperature	Compressor	12#_VK32_1	12# Compressor house	One	ASPEN
S12CP01_TT_109_LOGIC_PV	S12 CP01 After aftercooler temp	Compressor aftercooler temp	-	Temperature	Compressor	12#_VK32_1	12# Compressor house	One	ASPEN
S12CP01_ZT_101_LOGIC_PV	S12 CP01 Guide vane angle	Compressor guide vane angle	-	Status	Compressor	12#_VK32_1	12# Compressor house	One	ASPEN
S12CP02_FNT_109_LOGIC_PV	Comp Disch Normal Flow	Discharge normal flow rate	-	Flow	Compressor	12#_VK32_2	12# Compressor house	One	ASPEN
S01CP01_PT_108_LOGIC_PV	Compressor Discharge Pressure	Stage 4 Discharge Pressure	Supply	Pressure	Compressor	1#_VK50_1	1# Compressor house	Two	ASPEN
S01CP02_PT_108_LOGIC_PV	Stage 4 Discharge Pressure	Stage 4 Discharge Pressure	-	Pressure	Compressor	1#_VK50_2	1# Compressor house	Two	ASPEN
S12CP02_TT_108_LOGIC_PV	S12 CP02 Discharge temp	Compressor discharge temperature	-	Temperature	Compressor	12#_VK32_2	12# Compressor house	One	ASPEN
S12CP02_TT_109_LOGIC_PV	S12 CP02 After aftercooler temp	Compressor aftercooler temp	-	Temperature	Compressor	12#_VK32_2	12# Compressor house	One	ASPEN
S12CP02_ZT_101_LOGIC_PV	S12 CP02 Guide vane angle	Compressor guide vane angle	-	Status	Compressor	12#_VK32_2	12# Compressor house	One	ASPEN
S12CP02_ZT_109_LOGIC_PV	S12 CP02 Blow off position	Compressor blow off position	-	Status	Compressor	12#_VK32_2	12# Compressor house	One	ASPEN
S12CP03_FNT_109_PV	Comp Disch Normal Flow	Discharge normal flow rate	-	Flow	Compressor	12#_VK50_3	12# Compressor house	One	ASPEN
S12CP03_FT_109_PV	S12 CP03 Discharge flow rate	Discharge flow rate	Supply	Flow	Compressor	12#_VK50_3	12# Compressor house	One	ASPEN

Tag Name	Description	Type	Supply / Demand	Property	Operational unit	Unit #	Area	Ring	Data Source
S01CP02_PT_108_PV	Stage 4 Discharge Pressure	Stage 4 Discharge Pressure	Supply	Pressure	Compressor	1#_VK50_2	1# Compressor house	Two	ASPEN
S10CP01_PT_108_LOGIC_PV	Stage 4 Discharge Pressure	Stage 4 Discharge Pressure	-	Pressure	Compressor	10#_VK32_1	10# Compressor house	Two	ASPEN
S12CP03_TT_108_LOGIC_PV	S12 CP03 Discharge temp	Compressor discharge temperature	-	Temperature	Compressor	12#_VK50_3	12# Compressor house	One	ASPEN
S12CP03_TT_109_LOGIC_PV	S12 CP03 After aftercooler temp	Compressor aftercooler temp	-	Temperature	Compressor	12#_VK50_3	12# Compressor house	One	ASPEN
S12CP03_ZT_101_LOGIC_PV	S12 CP03 Guide vane angle	Compressor guide vane angle	-	Status	Compressor	12#_VK50_3	12# Compressor house	One	ASPEN
S12CP03_ZT_109_LOGIC_PV	S12 CP03 Blow off position	Compressor blow-off position	-	Status	Compressor	12#_VK50_3	12# Compressor house	One	ASPEN
S14CP01_FNT_109_LOGIC_PV	Compressor Discharge Normal Volumetric Flow	Discharge normal flow rate	-	Flow	Compressor	14#_VK50_1	14# Compressor house	One	ASPEN
S14CP01_FT_109_LOGIC_PV	S14 CP01 Discharge flow rate	Discharge flow rate	Supply	Flow	Compressor	14#_VK50_1	14# Compressor house	One	ASPEN
S10CP01_PT_108_PV	Stage 4 Discharge Pressure	Stage 4 Discharge Pressure	Supply	Pressure	Compressor	10#_VK32_1	10# Compressor house	Two	ASPEN
S10CP01_PT_109_PV	Stage 4 Discharge Pressure	Stage 4 Discharge Pressure	-	Pressure	Compressor	10#_VK32_1	10# Compressor house	Two	ASPEN
S14CP01_TT_108_LOGIC_PV	S14 CP01 Discharge temp	Compressor discharge temperature	-	Temperature	Compressor	14#_VK50_1	14# Compressor house	One	ASPEN
S14CP01_TT_109_LOGIC_PV	S14 CP01 After aftercooler temp	Compressor aftercooler temp	-	Temperature	Compressor	14#_VK50_1	14# Compressor house	One	ASPEN
S14CP01_ZT_101_LOGIC_PV	S14 CP01 Guide vane angle	Compressor guide vane angle	-	Status	Compressor	14#_VK50_1	14# Compressor house	One	ASPEN

Tag Name	Description	Type	Supply / Demand	Property	Operational unit	Unit #	Area	Ring	Data Source
S14CP01_ZT_109_LOGIC_PV	S14 CP01 Blow off position	Compressor blow-off position	-	Status	Compressor	14#_VK50_1	14# Compressor house	One	ASPEN
S14CP02_FNT_109_LOGIC_PV	Compressor Discharge Normal Volumetric Flow	Discharge normal flow rate	Supply	Flow	Compressor	14#_VK50_2	14# Compressor house	One	ASPEN
S14CP02_FT_109_LOGIC_PV	S14 CP02 Discharge flow rate	Discharge flow rate	-	Flow	Compressor	14#_VK50_2	14# Compressor house	One	ASPEN
S10CP02_PT_108_LOGIC_PV		Stage 4 Discharge Pressure	-	Pressure	Compressor	10#_VK32_2	10# Compressor house	Two	ASPEN
S11CP01_PT_108_LOGIC_PV	S11 CP01 Discharge pressure	Stage 4 Discharge Pressure	-	Pressure	Compressor	11#_VK32_1	11# Compressor house	One	ASPEN
S14CP02_TT_108_LOGIC_PV	S14 CP02 Discharge temp	Compressor discharge temperature	-	Temperature	Compressor	14#_VK50_2	14# Compressor house	One	ASPEN
S14CV01_FT_161A_LOGIC_PV	AnukPa Air Flow (CP#14 Flow rate)	Shaft flow	Demand	Flow	Shaft	14 #	14 #	One	ASPEN
S14CV01_PT_161B_LOGIC_PV	Compressed Air Pressure	Down-stream pressure	Demand	Pressure	Shaft	14 #	14 #	One	ASPEN
S14CV01_PT_UG01_LOGIC_PV	Compressed Air Pressure Underground	Shaft supply pressure	Demand	Pressure	Shaft	14 #	14 #	One	ASPEN
S14CP02_TT_109_LOGIC_PV	S14 CP02 After aftercooler temp	Compressor aftercooler temp	-	Temperature	Compressor	14#_VK50_2	14# Compressor house	One	ASPEN
S16CP01_FT_161A	Shaft flow	-	Demand	Flow	Shaft	16 #	16 #	Two	ASPEN
S14CP02_ZT_101_LOGIC_PV	S14 CP02 Guide vane angle	Compressor guide vane angle	-	Status	Compressor	14#_VK50_2	14# Compressor house	One	ASPEN
S14CP02_ZT_109_LOGIC_PV	S14 CP02 Blow off position	Compressor blow-off position	-	Status	Compressor	14#_VK50_2	14# Compressor house	One	ASPEN
S16CP01_FNT_109_LOGIC_PV	Comp Disch Normal Flow	Discharge normal flow rate	Supply	Flow	Compressor	16#_VK50_1	16# Compressor house	Two	ASPEN
S11CP02_PT_108_LOGIC_PV	S11 CP02 Discharge pressure	Stage 4 Discharge Pressure	-	Pressure	Compressor	11#_VK32_2	11# Compressor house	One	ASPEN

Tag Name	Description	Type	Supply / Demand	Property	Operational unit	Unit #	Area	Ring	Data Source
S16CP02_FNT_109_LOGIC_PV	Comp Disch Normal Flow	Discharge normal flow rate	Supply	Flow	Compressor	16#_VK50_2	16# Compressor house	Two	ASPEN
S16CV_FNT_121_LOGIC_PV	21 Level Air Flow to 1#	Level flow	Demand	Flow	Level	1 to 16	1 #	Two	ASPEN
S11CP03_PT_108_LOGIC_PV	S11 CP03 Discharge pressure	Stage 4 Discharge Pressure	-	Pressure	Compressor	11#_VK32_3	11# Compressor house	One	ASPEN
S16CP03_FNT_109_LOGIC_PV	Comp Disch Normal Flow	Discharge normal flow rate	Supply	Flow	Compressor	16#_VK50_3	16# Compressor house	Two	ASPEN
S12CP01_PT_108_LOGIC_PV	S12 CP01 Discharge pressure	Stage 4 Discharge Pressure	Supply	Pressure	Compressor	12#_VK32_1	12# Compressor house	One	ASPEN
S20CP01_FNT_109_LOGIC_PV	Compressor Discharge Normal Volumetric Flow	Discharge normal flow rate	-	Flow	Compressor	20#_VK32_1	20# Compressor house	One	ASPEN
S20CP01_FT_109_LOGIC_PV	S20 CP01 Discharge flow rate	Discharge flow rate	Supply	Flow	Compressor	20#_VK32_1	20# Compressor house	One	ASPEN
S12CP02_PT_108_LOGIC_PV	S12 CP02 Discharge pressure	Stage 4 Discharge Pressure	Supply	Pressure	Compressor	12#_VK32_2	12# Compressor house	One	ASPEN
S12CP03_PT_108_LOGIC_PV	S12 CP03 Discharge pressure	Stage 4 Discharge Pressure	Supply	Pressure	Compressor	12#_VK50_3	12# Compressor house	One	ASPEN
S20CP01_TT_108_LOGIC_PV	S20 CP01 Discharge temp	Compressor discharge temperature	-	Temperature	Compressor	20#_VK32_1	20# Compressor house	One	ASPEN
S20CP01_TT_109_LOGIC_PV	S20 CP01 After aftercooler temp	Compressor aftercooler temp	-	Temperature	Compressor	20#_VK32_1	20# Compressor house	One	ASPEN
S20CP01_ZT_101_LOGIC_PV	S20 CP01 Guide vane angle	Compressor guide vane angle	-	Status	Compressor	20#_VK32_1	20# Compressor house	One	ASPEN
S20CP01_ZT_109_LOGIC_PV	S20 CP01 Blow off position	Compressor blow-off position	-	Status	Compressor	20#_VK32_1	20# Compressor house	One	ASPEN
S20CP02_FNT_109_LOGIC_PV	Compressor Discharge Normal Volumetric Flow	Discharge normal flow rate	-	Flow	Compressor	20#_VK32_2	20# Compressor house	One	ASPEN

Tag Name	Description	Type	Supply / Demand	Property	Operational unit	Unit #	Area	Ring	Data Source
S20CP02_FT_109_LOGIC_PV	S20 CP02 Discharge flow rate	Discharge flow rate	Supply	Flow	Compressor	20#_VK32_2	20# Compressor house	One	ASPEN
S14CP01_PT_108_LOGIC_PV	Stage 4 Discharge Pressure	Stage 4 Discharge Pressure	-	Pressure	Compressor	14#_VK50_1	14# Compressor house	One	ASPEN
S14CP02_PT_108_LOGIC_PV	Stage 4 Discharge Pressure	Stage 4 Discharge Pressure	-	Pressure	Compressor	14#_VK50_2	14# Compressor house	One	ASPEN
S20CP02_TT_108_LOGIC_PV	S20 CP02 Discharge temp	Compressor discharge temperature	-	Temperature	Compressor	20#_VK32_2	20# Compressor house	One	ASPEN
S20CP02_TT_109_LOGIC_PV	S20 CP02 After aftercooler temp	Compressor aftercooler temp	-	Temperature	Compressor	20#_VK32_2	20# Compressor house	One	ASPEN
S20CP02_ZT_101_LOGIC_PV	S20 CP02 Guide vane angle	Compressor guide vane angle	-	Status	Compressor	20#_VK32_2	20# Compressor house	One	ASPEN
S20CP02_ZT_109_LOGIC_PV	S20 CP02 Blow off position	Compressor blow-off position	-	Status	Compressor	20#_VK32_2	20# Compressor house	One	ASPEN
S20CP03_FNT_109_LOGIC_PV	Compressor Discharge Normal Volumetric Flow	Discharge normal flow rate	-	Flow	Compressor	20#_VK32_3	20# Compressor house	One	ASPEN
S20CP03_FT_109_LOGIC_PV	S20 CP03 Discharge flow rate	Discharge flow rate	Supply	Flow	Compressor	20#_VK32_3	20# Compressor house	One	ASPEN
S16CP01_PT_108_LOGIC_PV		Stage 4 Discharge Pressure	Supply	Pressure	Compressor	16#_VK50_1	16# Compressor house	Two	ASPEN
S16CP02_PT_108_LOGIC_PV		Stage 4 Discharge Pressure	Supply	Pressure	Compressor	16#_VK50_2	16# Compressor house	Two	ASPEN
S20CP03_TT_108_LOGIC_LOGIC_PV	S20 CP03 Discharge temp	Compressor discharge temperature	-	Temperature	Compressor	20#_VK32_3	20# Compressor house	One	ASPEN
S20CV_FT_161A_LOGIC_PV	Main Annubar Air Flow	Shaft flow	Demand	Flow	Shaft	20 #	20 #	One	ASPEN
S20CV_TT_161A_LOGIC_PV	Shaft 20 Temp demand	Shaft temperature	Demand	Temperature	Shaft	20 #	20 #	One	ASPEN
SEFCR1_FT_161A_LOGIC_PV	Main Annubar Air Flow (Shaft)	Shaft flow	Demand	Flow	Shaft	22 #	22 #	One	ASPEN

Tag Name	Description	Type	Supply / Demand	Property	Operational unit	Unit #	Area	Ring	Data Source
U01L10_FT_109	Air Flow - 09 Level	Level flow	-	Flow	Level	Level 9?	1 #	Two	ASPEN
U01L10_FT_109_LOGIC_PV	Air Flow - 09 Level	Level flow	Demand	Flow	Level	Level 9	1 #	Two	ASPEN
U01L10_FT_111A	8588.231	Level flow	-	Flow	Level	Level 11 A?	1 #	Two	ASPEN
U01L10_FT_111A_LOGIC_PV	Air Flow 1- 11 Level	Level flow	Demand	Flow	Level	Level 11 A	1 #	Two	ASPEN
U01L10_FT_111B	0	Level flow	-	Flow	Level	Level 11 B?	1 #	Two	ASPEN
U01L10_FT_111B_LOGIC_PV	Air Flow 2- 11 Level	Level flow	Demand	Flow	Level	Level 11 B	1 #	Two	ASPEN
U01L10_FT_112A	Shaft 1 level 10 flow	Level flow	-	Flow	Level	Level 10	1 #	Two	ASPEN
U01L10_FT_112A_LOGIC_PV	Air Flow 1- 12 Level	Level flow	Demand	Flow	Level	Level 12 A	1 #	Two	ASPEN
U01L10_FT_112B	4116.229	Level flow	-	Flow	Level	Level 12 B?	1 #	Two	ASPEN
U01L10_FT_112B_LOGIC_PV	Air Flow 2- 12 Level	Level flow	Demand	Flow	Level	Level 12 B	1 #	Two	ASPEN
U01L10_FT_113A	Shaft 1 level 12 flow	Level flow	-	Flow	Level	Level 12	1 #	Two	ASPEN
U01L10_FT_113A_LOGIC_PV	Air Flow 1- 13 Level	Level flow	Demand	Flow	Level	Level 13 A	1 #	Two	ASPEN
U01L10_FT_113B	Shaft 1 level 13 flow	Level flow	-	Flow	Level	Level 13	1 #	Two	ASPEN
U01L10_FT_113B_LOGIC_PV	Air Flow 2- 13 Level	Level flow	Demand	Flow	Level	Level 13 B	1 #	Two	ASPEN
U01L10_FT_114	Shaft 1 level 14 flow	Level flow	-	Flow	Level	Level 14	1 #	Two	ASPEN
U01L10_FT_114_LOGIC_PV	Air Flow - 14 Level	Level flow	Demand	Flow	Level	Level 14	1 #	Two	ASPEN
U01L10_FT_115	Shaft 1 level 15 flow	Level flow	-	Flow	Level	Level 15	1 #	Two	ASPEN
U01L10_FT_115_LOGIC_PV	Air Flow - 15 Level	Level flow	Demand	Flow	Level	Level 15	1 #	Two	ASPEN
U01L10_FT_116_LOGIC_PV	Air Flow - 16 Level	Level flow	Demand	Flow	Level	Level 16	1 #	Two	ASPEN
U01L10_FT_161A_LOGIC_PV	Annubar Air Flow - 10 Level	Level flow	Demand	Flow	Level	Level 10	1 #	Two	ASPEN
S20CV_PT_161A_LOGIC_PV	Main Annubar Air Pressure	Shaft supply pressure	Demand	Pressure	Shaft	20 #	20 #	One	ASPEN
U01L10_TT_161A_LOGIC_PV	Annubar Air Temperature - 10 Lev	Level air temperature	Demand	Temperature	Level	Level 10	1 #	Two	ASPEN
S11CCH01_FNT_001_LOGIC_PV		Shaft flow	Demand	Flow	Shaft	11 C #	11 C #	One	ASPEN
S11CCH01_PT_002_LOGIC_PV		Shaft column pressure	Demand	Pressure	Shaft	11 C #	11 C #	One	ASPEN
U11CVC4_FT_013_LOGIC_PV		Level flow	Demand	Flow	Level	Level 13	11 #	One	ASPEN
S04BI_PT_161A_VAL	S4 Pressure demand	Shaft supply pressure	Demand	Pressure	Shaft	4 #	4 #	One	ASPEN
U11CVC4_FT_014_LOGIC_PV		Level flow	Demand	Flow	Level	Level 14	11 #	One	ASPEN
U11CVC4_FT_015_LOGIC_PV	15LLevel Compressed Air Flow	Level flow	Demand	Flow	Level	Level 15	11 #	One	ASPEN

Tag Name	Description	Type	Supply / Demand	Property	Operational unit	Unit #	Area	Ring	Data Source
S06BI_PT_161A_VAL	Annubar Air Pressure - Bank	Shaft supply pressure	Demand	Pressure	Shaft	6 #	6 #	One	ASPEN
S09BI_PT_161A_VAL	Annubar Air Pressure - Bank	Shaft supply pressure	Demand	Pressure	Shaft	9 #	9 #	Two	ASPEN
S09BI_PT_161B_VAL	Compressed Air Pressure - Bank	Shaft supply pressure	-	Pressure	Shaft	9 #	9 #	Two	ASPEN
S20CP03_TT_109_LOGIC_LOGIC_PV	S20 CP03 After aftercooler temp	Compressor aftercooler temp	-	Temperature	Compressor	20#_VK32_3	20# Compressor house	One	ASPEN
S20CP03_ZT_101_LOGIC_PV	S20 CP03 Guide vane angle	Compressor guide vane angle	-	Status	Compressor	20#_VK32_3	20# Compressor house	One	ASPEN
S20CP03_ZT_109_LOGIC_PV	S20 CP03 Blow off position	Compressor blow-off position	-	Status	Compressor	20#_VK32_3	20# Compressor house	One	ASPEN
S16CP03_PT_108_LOGIC_PV		Stage 4 Discharge Pressure	Supply	Pressure	Compressor	16#_VK50_3	16# Compressor house	Two	ASPEN
S02SCP01_PT_108_LOGIC_PV		Stage 4 Discharge Pressure	-	Pressure	Compressor	2#_VK32_1	2# Compressor house	Two	ASPEN
S02SCP02_PT_108_LOGIC_PV		Stage 4 Discharge Pressure	-	Pressure	Compressor	2#_VK32_2	2# Compressor house	Two	ASPEN
S20CP01_PT_108_LOGIC_PV	S20 CP01 Discharge pressure	Stage 4 Discharge Pressure	-	Pressure	Compressor	20#_VK32_1	20# Compressor house	One	ASPEN
S20CP02_PT_108_LOGIC_PV	S20 CP02 Discharge pressure	Stage 4 Discharge Pressure	-	Pressure	Compressor	20#_VK32_2	20# Compressor house	One	ASPEN
S02CP_PT_101_LOGIC_PV	Processing Plant Flow	Process plant pressure	Demand	Pressure	Process plant	PROCESSING PLANT	PROCESSING PLANT	One	ASPEN
S02CP_FT_101_LOGIC_PV	Processing Plant Header	Process plant flow	Demand	Flow	Process plant	PROCESSING PLANT	PROCESSING PLANT	One	ASPEN
S20CP03_PT_108_LOGIC_LOGIC_PV	S20 CP03 Discharge pressure	Stage 4 Discharge Pressure	-	Pressure	Compressor	20#_VK32_3	20# Compressor house	One	ASPEN

Tag Name	Description	Type	Supply / Demand	Property	Operational unit	Unit #	Area	Ring	Data Source
S20CP03_PT_108_LOGIC_PV		Stage 4 Discharge Pressure	-	Pressure	Compressor	20#_VK32_3	20# Compressor house	One	ASPEN
S07CP01_PT_108_LOGIC_PV	Stage 4 Discharge Pressure	Stage 4 Discharge Pressure	Supply	Pressure	Compressor	7#_VK32_1	7# Compressor house	One	ASPEN
1 SHAFT 6.6kV SUB_5MW COMPRESSOR FDR1 (kW Imp)	VK50	Power	Supply	Power	Compressor	1#_VK50_1	1# Compressor house	Two	IST/ASTIR
1 SHAFT 6.6kV SUB_DEMAG COMPRESSOR FDR3 (kW Imp)	VK50 (VK32 housing)	Power	Supply	Power	Compressor	1#_VK32_3	1# Compressor house	Two	IST/ASTIR
1 SHAFT 6.6kV SUB_VK50 COMPRESSOR NR2 (kW Imp)	VK50	Power	Supply	Power	Compressor	1#_VK50_2	1# Compressor house	Two	IST/ASTIR
10 SHAFT COMPRESSOR SUB_COMPRESSOR1 (kW Imp)	VK32	Power	Supply	Power	Compressor	10#_VK32_1	10# Compressor house	Two	IST/ASTIR
10 SHAFT COMPRESSOR SUB_COMPRESSOR2 (kW Imp)	VK32	Power	Supply	Power	Compressor	10#_VK32_2	10# Compressor house	Two	IST/ASTIR
11 SHAFT 6.6kV SUB_COMPRESSOR FDR1 (kW Imp)	VK 32	Power	Supply	Power	Compressor	11#_VK32_1	11# Compressor house	One	IST/ASTIR
11 SHAFT 6.6kV SUB_COMPRESSOR FDR2 (kW Imp)	VK 32	Power	Supply	Power	Compressor	11#_VK32_2	11# Compressor house	One	IST/ASTIR
11 SHAFT 6.6kV SUB_COMPRESSOR FDR3 (kW Imp)	VK 32	Power	Supply	Power	Compressor	11#_VK32_3	11# Compressor house	One	IST/ASTIR
12 SHAFT COMPRESSOR SUB_5.1MW COMPRESSOR (kW Imp)	VK 50	Power	Supply	Power	Compressor	12#_VK50_3	12# Compressor house	One	IST/ASTIR
12 SHAFT COMPRESSOR SUB_VK32 COMPRESSOR1 (kW Imp)	VK 32	Power	Supply	Power	Compressor	12#_VK32_1	12# Compressor house	One	IST/ASTIR
12 SHAFT COMPRESSOR SUB_VK32 COMPRESSOR2 (kW Imp)	VK 32	Power	Supply	Power	Compressor	12#_VK32_2	12# Compressor house	One	IST/ASTIR
14 SHAFT COMPRESSOR SUB_INCOMER1 (kW Imp)	VK 50	Power	Supply	Power	Compressor	14#_VK50_1	14# Compressor house	One	IST/ASTIR
14 SHAFT COMPRESSOR SUB_INCOMER2 (kW Imp)	VK 50	Power	Supply	Power	Compressor	14#_VK50_2	14# Compressor house	One	IST/ASTIR
16 SHAFT COMPRESSOR SUB_COMPRESSOR FDR1 (kW Imp)	VK50	Power	Supply	Power	Compressor	16#_VK50_1	16# Compressor house	Two	IST/ASTIR
16 SHAFT COMPRESSOR SUB_COMPRESSOR FDR2 (kW Imp)	VK50	Power	Supply	Power	Compressor	16#_VK50_2	16# Compressor house	Two	IST/ASTIR
16 SHAFT COMPRESSOR SUB_COMPRESSOR FDR3 (kW Imp)	VK50	Power	Supply	Power	Compressor	16#_VK50_3	16# Compressor house	Two	IST/ASTIR
2 SHAFT 6.6kV SUB_COMPRESSOR FDR1 (kW Imp)	VK32	Power	Supply	Power	Compressor	2#_VK32_1	2# Compressor house	Two	IST/ASTIR

Tag Name	Description	Type	Supply / Demand	Property	Operational unit	Unit #	Area	Ring	Data Source
2 SHAFT 6.6kV SUB_COMPRESSOR FDR2 (kW Imp)	VK32	Power	Supply	Power	Compressor	2#_VK32_2	2# Compressor house	Two	IST/ASTIR
20 SHAFT 6.6kV SUB_COMPRESSOR FDR1 (kW Imp)	VK 32	Power	Supply	Power	Compressor	20#_VK32_1	20# Compressor house	One	IST/ASTIR
20 SHAFT 6.6kV SUB_COMPRESSOR FDR2 (kW Imp)	VK 32	Power	Supply	Power	Compressor	20#_VK32_2	20# Compressor house	One	IST/ASTIR
20 SHAFT 6.6kV SUB_COMPRESSOR FDR3 (kW Imp)	VK 32	Power	Supply	Power	Compressor	20#_VK32_3	20# Compressor house	One	IST/ASTIR
5B SHAFT 6.6kV SUB_COMPRESSOR FDR (kW Imp)	VK 32	Power	Supply	Power	Compressor	5B#_VK3_2_1	5B Compressor house	One	IST/ASTIR
7 SHAFT 6.6kV SUB_COMPRESSOR1 (kW Imp)	VK 32	Power	Supply	Power	Compressor	7#_VK32_1	7# Compressor house	One	IST/ASTIR
7 SHAFT 6.6kV SUB_COMPRESSOR2 (kW Imp)	VK 32	Power	Supply	Power	Compressor	7#_VK32_2	7# Compressor house	One	IST/ASTIR
7 SHAFT 6.6kV SUB_COMPRESSOR3 (kW Imp)	Auxiliaries	Power	Supply	Power	Compressor	7#_VK32_3	7# Compressor house	One	IST/ASTIR
9 SHAFT COMPRESSOR SUB_COMPRESSOR1 (kW Imp)	VK32	Power	Supply	Power	Compressor	9#_VK32_1	9# Compressor house	Two	IST/ASTIR
CENTRAL COMPRESSOR SUB_VK32 COMPRESSOR1 (kW Imp)	VK 32	Power	Supply	Power	Compressor	Cen#_VK32_1	Central compressor house	One	IST/ASTIR
CENTRAL COMPRESSOR SUB_VK32 COMPRESSOR2 (kW Imp)	VK 32	Power	Supply	Power	Compressor	Cen#_VK32_2	Central compressor house	One	IST/ASTIR
CENTRAL COMPRESSOR SUB_VK32 COMPRESSOR3 (kW Imp)	VK 32	Power	Supply	Power	Compressor	Cen#_VK32_3	Central compressor house	One	IST/ASTIR
CENTRAL COMPRESSOR SUB_250kVA TRANSFORMER (kW Imp)	Transformer	Power	-	Power	Transformer	Cen_250_kVA	Central compressor house	One	IST/ASTIR
CENTRAL COMPRESSOR SUB_750kVA TRANSFORMER (kW Imp)	Transformer	Power	-	Power	Transformer	Cen_750_kVA	Central compressor house	One	IST/ASTIR
CENTRAL COMPRESSOR SUB_VK50 COMPRESSOR4 (kW Imp)	VK 50	Power	Supply	Power	Compressor	Cen#_VK50_4	Central compressor house	One	IST/ASTIR
S10CP01_FNT_109_LOGIC_PV	CP01 Supply Flow	Discharge normal flow rate	Supply	Flow	Compressor	10#_VK32_1	10# Compressor house	Two	ASPEN

Tag Name	Description	Type	Supply / Demand	Property	Operational unit	Unit #	Area	Ring	Data Source
S10CP02_FNT_109_LOGIC_PV	CP02 Supply Flow	Discharge normal flow rate	Supply	Flow	Compressor	10#_VK32_2	10# Compressor house	Two	ASPEN
S01CP02_FNT_109_LOGIC_PV	CP02 Supply Flow	Discharge normal flow rate	Supply	Flow	Compressor	1#_VK50_2	1# Compressor house	Two	ASPEN
S12CP03_FNT_109_LOGIC_PV	CP03 Supply Flow	Discharge normal flow rate	Supply	Flow	Compressor	12#_VK32_2	12# Compressor house	One	ASPEN
U11CVC4_FT_017_LOGIC_PV		Level flow	Demand	Flow	Level	Level 17	11 #	One	ASPEN
U11CVC4_FT_018_LOGIC_PV		Level flow	Demand	Flow	Level	Level 18	11 #	One	ASPEN
U11CVC4_FT_019_LOGIC_PV		Level flow	Demand	Flow	Level	Level 19	11 #	One	ASPEN
U11CH01_FT020A_PV		Level flow	Demand	Flow	Level	Level 20 A	11 #	One	ASPEN
U11CH01_FT020B_PV		Level flow	Demand	Flow	Level	Level 20 B	11 #	One	ASPEN
U11CH01_FT020C_PV		Level flow	Demand	Flow	Level	Level 20 C	11 #	One	ASPEN
U11CH01_FT021A_PV		Level flow	Demand	Flow	Level	Level 21 A	11 #	One	ASPEN
U11CH01_FT021B_PV		Level flow	Demand	Flow	Level	Level 21 B	11 #	One	ASPEN
U11CVC5_FT_022A_LOGIC_PV		Level flow	Demand	Flow	Level	Level 22 A	11 #	One	ASPEN
U11CVC5_FT_022B_LOGIC_PV		Level flow	Demand	Flow	Level	Level 22 B	11 #	One	ASPEN
U11CVT2_FT_023_LOGIC_PV		Level flow	Demand	Flow	Level	Level 23	11 #	One	ASPEN
U11CVT3_FT_024A_LOGIC_PV	Level 28/24?	Level flow	Demand	Flow	Level	Level 24 A	11 C #	One	ASPEN
U11CVT3_FT_024B_LOGIC_PV	Level 28/24?	Level flow	Demand	Flow	Level	Level 24 B	11 C #	One	ASPEN
U11CVT4_FT_025A_LOGIC_PV	25 Level Compressed Air Flow	Level flow	Demand	Flow	Level	Level 25 A	11 C #	One	ASPEN
U11CVT4_FT_025N_LOGIC_PV	25 Level Compressed Air One FI	Half Level flow	Demand	Flow	Haulage	Level 25 NF1	11 C #	One	ASPEN
U11CVT4_FT_025S_LOGIC_PV		Half Level flow	Demand	Flow	Haulage	Level 25 S	11 C #	One	ASPEN
U14CL_FNT_024_LOGIC_PV		Level flow	Demand	Flow	Level	Level 24	14 #	One	ASPEN
U14CL_FNT_025_LOGIC_PV		Level flow	Demand	Flow	Level	Level 25	14 #	One	ASPEN
U14CL_FNT_026_LOGIC_PV		Level flow	Demand	Flow	Level	Level 26	14 #	One	ASPEN
U14CL_FNT_027_LOGIC_PV		Level flow	Demand	Flow	Level	Level 27	14 #	One	ASPEN
U14CL_FNT_028_LOGIC_PV		Level flow	Demand	Flow	Level	Level 28	14 #	One	ASPEN
U14CL_FNT_200_LOGIC_PV		Level flow	-	Flow	Level	Decline	14 #	One	ASPEN
U14CL_FT_022_LOGIC_PV		Level flow	Demand	Flow	Level	Level 22	14 #	One	ASPEN
U14CVC1_FNT_021_LOGIC_PV		Level flow	Demand	Flow	Level	Level 21	14 #	One	ASPEN

Tag Name	Description	Type	Supply / Demand	Property	Operational unit	Unit #	Area	Ring	Data Source
SEFCR1_PT_161A_LOGIC_PV	Main Annubar Air Pressure (Valve Station)	Shaft supply pressure	Demand	Pressure	Shaft	22 #	22 #	One	ASPEN
U11CVT5_FT_026A_LOGIC_PV		Level flow	Demand	Flow	Level	Level 26 A	11 C #	One	ASPEN
U11CCVC7_FIQ_27LG1_LOGIC_PROGTO TAL	27L Compressed Air Totaliser	Level flow	-	Flow	Level	Level 27	11 C #	One	ASPEN
U01L10_XV_161A_LOGIC_OPEN	Compressed Air Shut-Off Valve - 10 Level	Valve status	Demand	Status	Shaft	1 #	1 #	Two	ASPEN
S16CV_XV_401_LOGIC_OPEN	1# valve 2, supply from 16#	Valve status	Demand	Status	Shaft	1 #	1 #	Two	ASPEN
S09BI_XV_161A_LOGIC_OPEN	Compressed Air Shut-Off Valve - Bank	Valve status	Demand	Status	Shaft	9 #	9 #	Two	ASPEN
S10CP02_XV_161A_LOGIC_OPEN	Compressed Air Shut-Off Valve - Bank	Valve status	Demand	Status	Shaft	10 #	10 #	Two	ASPEN
S10BI_XV_165A_LOGIC_OPEN	Compressed Air Shut-Off Valve - 10# 15	Valve status	Demand	Status	Shaft	10 #	10 #	Two	ASPEN
S07CP01_FNT_109_Logic_PV	CP01 Supply Flow	Discharge normal flow rate	Supply	Flow	Compressor	7#_VK32_1	7# Compressor house	One	ASPEN
S07CP02_FNT_109_Logic_PV	CP02 Supply Flow	Discharge normal flow rate	Supply	Flow	Compressor	7#_VK32_2	7# Compressor house	One	ASPEN
S07CP03_FNT_109_Logic_PV	CP03 Supply Flow	Discharge normal flow rate	Supply	Flow	Compressor	7#_VK32_3	7# Compressor house	One	ASPEN