

# **Nigerian coal power stations: Their future in the light of global warming**

**E.N. EZIUKWU (B.Eng)**

**20905912**

Dissertation submitted in partial fulfilment of the requirements for the degree  
Master of Engineering (Development and Management)  
at the Potchefstroom campus of the North-West University

**Supervisor: Professor P. W. STOKER**

**November 2008**

## **ACKNOWLEDGEMENT**

I would like to start by thanking the Almighty God who gave me the strength and wisdom to accomplish this feat. With Him "there is no variableness neither shadow of turning", He is most dependable.

This dissertation would not have been achievable without the support and insights of my indefatigable supervisor Prof P.W. Stoker, who provided me with the necessary guidance all through the stages of this work.

I want to appreciate specifically Engr L.C. Iwuagwu of the Power Holding Company of Nigeria for all the support and insights he gave me on the Oji river power station. To Engr Frank Amanoh of the Nigerian coal corporation, a very big thank you for your kind disposition. Engrs. Olu, Yusuf and Olayande of the Energy commission of Nigeria and Engr S.O. Oladipo of the ministry of solid minerals development, your assistance and encouragement have yielded results.

I want to thank Dr Dale Simbeck of SFA Pacific Inc. for his professional advice and wealth of experience which he shared freely in the area of CO<sub>2</sub> mitigation economics.

My thanks and appreciation goes to all my family members (especially my parents) and friends who assisted and encouraged me in one way or the other. Time and space will fail me to mention all your names here; your invaluable contributions are indeed recognised.

Lastly, and most importantly, my darling wife deserves special tribute for supporting and encouraging me in no small measure; I recount all your sacrifices to accommodate this course.

*This dissertation is dedicated to my loving wife, Mrs. Ngozi Helen Eziukwu.*

## **ABSTRACT**

Nigeria is presently being faced with a growing electricity demand problem following its population growth rate. The total installed capacity is far less than the current demand for electricity supply. As a way of bridging out this supply gap, the federal government is mobilizing all of its potential energy options.

Coal is widely used for power generation in many countries. But today, the continued usage of coal for power generation is being challenged by the disturbing global warming phenomenon. This is due to the quantity of uncontrolled carbon dioxide emission from traditional coal-fired power plants.

The aim of this dissertation is to critically analyse the future of the Nigerian coal power stations following the need to do carbon dioxide emission control necessary for ensuring a sustainable environment. Achieving this aim entails the appraisal of environmental regulation standards and cost structures of carbon dioxide (CO<sub>2</sub>) emission reduction options for the coal power stations.

Controlling carbon dioxide emission from existing coal power stations requires retrofit system that captures and effectively sequesters the captured CO<sub>2</sub>. The cost and performance effect of the CO<sub>2</sub> retrofit system on the existing power plant can be simulated with standard computer software models. In this study the IECM-cs computer modeling tool for power plants was used in determining the cost and performance impacts of applying an Amine-based CO<sub>2</sub> capture system to the Oji river power station in Nigeria.

With the IECM-cs model, it was established that reducing CO<sub>2</sub> emission imposes an additional cost on the power plant which increases the unit cost of electricity generated. This additional cost index requires economic justification for its acceptance. This is due to the need to demonstrate its viability judging from the cost of electricity generated from other sources in the Nigerian economy. For the Oji river case, the station is old and requires extensive renovation. This causes a

cost escalation over and above the cost associated with the CO<sub>2</sub> sequestration system. As such, Oji coal power station does not have an economic future if CO<sub>2</sub> emission sequestration becomes obligatory.

The future of coal power stations in Nigeria can be considered from two scenarios: one where the current national environmental standard is retained and another where it is revised. The revision classifies CO<sub>2</sub> as a pollutant which makes its emission reduction imperative for coal power plants. Under the current standard, building modern large capacity pulverized coal-fired power plants with improved steam cycles should be encouraged. But with the review of the national standard, the focus should be on building new large capacity coal power stations with integrated CO<sub>2</sub> emission control. This will ensure an environmentally friendly future for coal power stations in Nigeria.

**Keywords:** global warming, coal, carbon dioxide emission, Kyoto protocol, Nigeria, sustainable environment, cost of electricity, power station, clean coal technologies, CO<sub>2</sub> capture, CO<sub>2</sub> sequestration.

# TABLE OF CONTENT

Title Page .....	I
Acknowledgement .....	II
Abstract .....	III
Table of Content .....	V
List of Tables .....	VIII
List of Figures .....	IX
List of Abbreviations.....	X

<b>CHAPTER ONE: INTRODUCTION .....</b>	<b>1</b>
1.1 Background .....	1
1.2 Problem Statement and Substantiation .....	3
1.3 Research Aim and Objectives .....	5
1.4 Research Scope .....	6
1.5 Research Outline .....	7

<b>CHAPTER TWO: LITERATURE REVIEW .....</b>	<b>8</b>
2.1 Global warming .....	8
2.1.1 Introduction .....	8
2.1.2 What is global warming .....	9
2.1.3 Causes of Global Warming .....	9
2.1.3.1 The Basic Science of Global Warming .....	10
2.1.3.2 CO <sub>2</sub> as the Main Contributor .....	12
2.1.3.3 Measuring the Atmospheric CO <sub>2</sub> .....	13
2.1.4 Effects of Global Warming .....	14
2.1.5 Controlling Global Warming .....	15
2.2 Coal .....	17
2.2.1 Coal utilization History.....	17
2.2.2 Coal Usage and Environmental Regulation .....	19
2.2.2.1 Coal-fired Power stations .....	19
2.2.3 The Future of Coal Power stations.....	24

2.2.4	Clean Coal Technologies .....	28
2.2.4.1	Carbon capture and Sequestration (CCS) .....	29
2.2.5	Conclusion .....	32
<b>CHAPTER THREE: EMPIRICAL INVESTIGATION .....</b>		<b>33</b>
3.1	Research Methodology .....	33
3.1.1	Research Approach .....	33
3.1.2	Data Gathering .....	33
3.1.2.1	CO <sub>2</sub> Emission Rate .....	34
3.1.2.2	Oji Plant Specific Data .....	35
3.1.2.3	CO <sub>2</sub> Capture and Sequestration Cost .....	36
3.2	Economics of GHG Emission Control .....	37
3.3	Verification and Validation .....	38
<b>CHAPTER FOUR: RESULTS AND DISCUSS .....</b>		<b>39</b>
4.1	Field Results .....	39
4.1.1	Case Study .....	39
4.1.1.1	Carbon dioxide Emission .....	39
4.1.1.2	Oji Plant Specific Data .....	41
4.1.1.3	CO <sub>2</sub> Capture and Sequestration Cost .....	43
4.1.2	IECM-cs Overview .....	44
4.1.3	Cost of Electricity Generated .....	45
4.1.4	Capacity Scaling .....	47
4.2	Results Analysis .....	48
4.2.1	Scenario 1 .....	48
4.2.1.1	Oji Base Case Analysis (30MW Plant) .....	48
4.2.1.2	Base Case Retrofit Analysis .....	51
4.2.2	Scenario 2 .....	54
4.2.2.1	Conceptual Base Plant Analysis .....	55
4.2.2.2	Conceptual Base Plant's Retrofit Analysis .....	59
4.2.3	Cost of CO <sub>2</sub> Avoided .....	63

4.3	Discussion of Results .....	64
4.3.1	Future of Nigerian coal power stations .....	64
4.3.1.1	GHG Emission Control in Nigeria .....	65
4.3.1.2	Power Generation Options .....	70
4.3.1.3	Clean Coal Technology .....	78
4.3.1.4	Economy of Scale .....	80
4.4	Validation of Results .....	81
 <b>CHAPTER FIVE: CONCLUSION AND RECOMMENDATION .....</b>		<b>85</b>
5.1	Conclusion .....	85
5.1.1	Introduction .....	85
5.1.2	Continued Coal Utilization .....	85
5.1.3	The way forward for Nigerian Coal Power Stations .....	86
5.1.3.1	Under the Current Standards.....	87
5.1.3.2	The Reviewed Standards .....	88
5.2	Recommendation .....	89
5.2.1	Government Policy .....	89
5.2.2	Other Recommendations .....	90
5.2.3	Further Research .....	90
 Appendix A.....		 92
Appendix B.....		94
Appendix C.....		96
Bibliography .....		97

## List of Tables

Table 2.1: Range of National emission standards for particulates, SO <sub>2</sub> and NO <sub>x</sub> (mg/m <sup>3</sup> ) for new coal-fired plants.....	23
Table 4.1: Results of emission monitoring from a live plant.....	40
Table 4.2: Comparison of the Base and Retrofitted plants (Scenario 2).....	63
Table 4.3: Estimated future installed electricity generation by fuel mix.....	71
Table 4.4: Comparison of CO <sub>2</sub> sequestration of Coal and Gas stations.....	74

## List of Figures

Figure 2.1: Pictorial illustration of the Normal (healthy) Greenhouse Effect.....	11
Figure 2.2: Pictorial illustration of Excessive (abnormal) Greenhouse Effect.....	11
Figure 2.3: World's coal demand for power generation.....	18
Figure 2.4: World Electricity Generation by Fuel type.....	20
Figure 2.5: Energy Price Trends of Oil Vs Gas Vs Coal .....	21
Figure 2.6: Carbon Capture and Sequestration Scheme.....	30
Figure 4.1: Simplified Gas side Process flow diagram of Oji Power station.....	49
Figure 4.2: Modified Gas side Process flow diagram of Base case plant.....	52
Figure 4.3: Scenario 2 Base plant process flow diagram.....	55
Figure 4.4: IECM interface showing cost factor inputs for Base Plant.....	57
Figure 4.5: IECM interface Base Plant Cost outputs.....	58
Figure 4.6: IECM interface Plant Flue gas output.....	59
Figure 4.7: Modified process flow diagram of the scenario 2 base plant.....	60
Figure 4.8: Scenario 2 Flue gas analysis for the Retrofitted plant.....	61
Figure 4.9: Effect of CO <sub>2</sub> retrofit cost on Scenario 2 Base Plant.....	62
Figure 4.10: Graph of Cost of CO <sub>2</sub> avoided.....	64
Figure 4.11: Major sources of CO <sub>2</sub> emission in Nigeria.....	66
Figure 4.12: Projected effect of CO <sub>2</sub> on Global warming in Nigeria.....	66
Figure 4.13: Impact of CO <sub>2</sub> Capture on Net Power Output.....	74
Figure 4.14: Achievable CO <sub>2</sub> Emission Reduction.....	75
Figure 4.15: Impact of CO <sub>2</sub> Capture on levelized cost of electricity.....	75
Figure 4.16: Estimated Subcritical PC Plant cost.....	81
Figure 4.17: Specific overnight construction costs of coal-fired power plants.....	82
Figure 4.18: Levelized costs of coal generated electricity at 5% discount rate....	82
Figure 4.19: Levelized costs of coal generated electricity at 10% discount rate..	82
Figure 4.20: Industrial application of the MEA-based CO <sub>2</sub> Capture system.....	84

## List of Abbreviations

Bbl/d	Barrels per day
BTU	British Thermal Unit
CCS	Carbon Capture and Sequestration
CDM	Clean Development Mechanism
COE	Cost of Electricity
CO <sub>2</sub>	Carbon dioxide
CRF	Capital Recovery Factor
ECN	Energy Commission of Nigeria
ESP	Electrostatic Precipitator
FEPA	Federal Environmental Protection Agency
FGD	Flue Gas Desulfurization
FGN	Federal Government of Nigeria
GJ	Gigajoule
GHG	Greenhouse Gas
GW	Gigawatts
GWe	Gigawatts-equivalent
GWP	Global Warming Potential
HHV	Higher Heating Value
Hr	Hour
IEA	International Energy Agency
IECM	Integrated Environmental Control Model
IGCC	Integrated Gasification Combined Cycle
IPCC	Intergovernmental Panel on Climate Change
JI	Joint Implementation
kCal	Kilocalorie
kg	Kilogram
kV	Kilovolts
kWh	Kilowatt-hour
Lb	Pound
Lb/hr	Pounds per hour

LNB	Low NO <sub>x</sub> Burner
LULUCF	Land use, Land-use Change and Forestry
Mcf	thousand cubic feet
MEA	Mono Ethanol Amine
Mm	Millimeter
MOE	Ministry of Environment
MSMD	Ministry of Solid Minerals Development
MW	Megawatts
MYTO	Multi Year Tariff Order
NCC	Nigerian Coal Corporation
NEEDS	National Economic Empowerment and Development Strategy
NERC	National Electricity Regulatory Commission
O&M	Operating and Maintenance Costs
PSI	Pounds per Square Inch
NGCC	Natural Gas Combined Cycle
PC	Pulverized Coal
PHCN	Power Holding Company of Nigeria
Ppm	Parts Per Million
RPM	Revolutions per Minute
SNCR	Selective Non-Catalytic Reduction
Tcf	trillion cubic feet
TCR	Total Capital requirement
Te/d	Tonnes per day
UNFCCC	United Nations Framework Convention on Climate Change
WCI	World Coal Institute

*This page is intentionally left blank*

# CHAPTER ONE

## INTRODUCTION

### 1.1 Background

Our world today is characterized by many concerns about sustainable development issues. The concept of sustainable development was introduced by the United Nations “World Commission on Environment and Development” (The Brundtland commission) in the year 1983 [Bradbrook, Lyster, Ottinger, Xi, 2005]. Sustainable development is founded upon these three pillars of economic growth, social equity and environmental quality. Up till date, the challenge remains improving the humans’ standard of living without destroying the environment. The big question therefore is finding the way forward. This particular focus has given birth to many international conferences, more so the grand earth summit held in 1992 at Rio de Janeiro, Brazil which brought many world leaders together from different countries under the United Nations auspices to discuss extensively on environment and development. [Microsoft Encarta, 2006; UN-NGLS, 2000]

The widening increase for energy demand and the quest for energy source diversification is a current trend that is opening up a range of opportunities for exploring different energy resources as well as finding their optimal utilization. Thus the growing global energy demand problem is forcing every economy to diversify its local energy resources as a means of achieving an appreciable level of energy security and economic stability [Chevron Corporation, 2007]

As the need for energy consumption increases so does its attendant issues increase alongside it. The various energy source options available present a range of challenges to deal with. A typical example of such challenge is the rising temperature of the earth due to inadvertent emission of greenhouse gases (GHGs), from the combustion of fossil fuels, causing increased global warming and climate change. [ConocoPhillips, 2007; Lee, 1996] As such, the global warming threat is fast becoming a new way for defining, determining and measuring how far most of the energy resources will thrive.

The situation for coal is such that the current global warming awareness is placing a new outlook on its numerous industries and utilization options. Recently in the USA, securing a license to build and operate a coal-fired electric power station demands providing evidence of a viable means of emission control in the operations of the plant. About 20 new coal-fired power stations implementation plans in the USA have been cancelled for lack of GHG emission control mechanism in their operations flow [Smith, 2007]. This type of trend is now on the increase around the world and will still affect many upcoming coal power projects should they not provide for curbing the causes and effects of global warming and climate change.

In an emerging economy like Nigeria with its many energy options, viz oil and gas, coal, hydro, wind, solar, geothermal, nuclear, biomass; much opportunities abound for electricity generation. However, coal in Nigeria has been extensively

explored and utilized in the past for power generation until lately when a sharp decline in its production was recorded, see Appendix A. This method of coal utilization involves the combustion of the coal in order to release and tap its energy content. But the combustion of coal emits carbon dioxide (CO<sub>2</sub>) which is one of the major greenhouse gases (GHG) causing global warming.

## **1.2 Problem Statement and Substantiation**

With the discovery of vast oil and gas deposits in the coastal Niger delta region of Nigeria in the late 1950s, a shift in the energy outlook of the Nigerian economy was recorded. Coupled with the oil boom that Nigeria experienced in 1973 when OPEC hiked the price of crude oil through which it gained much foreign exchange [Microsoft Encarta, 2006]. Ever since then, coal which has earlier been predominantly used for electricity generation started suffering a decline due to the preference of oil and gas based options.

Presently, with strong international oil politics/policies on price regulation and the growing local instability in the Niger delta region of Nigeria, the need has arisen to strengthen other energy contributors locally. According to APS Review - "Since December 2005, Nigeria has experienced increased pipeline vandalism, kidnappings, and militant takeover of oil and gas facilities in the Niger Delta". This has affected the operations of its gas-fired power stations. [APS, 2007] "As of April 2007, an estimated 587,000 bbl/d of crude production is shut-in" [EIA, 2007]. To build a sustainable energy economy, the Federal Government of

Nigeria (FGN) is therefore determined to encourage the growth of its non-oil energy sector as a national economic development strategy [NEEDS, 2004].

This sudden government's interest in reviving the coal power industry in order to solve its electricity demand/supply crisis requires critical evaluation. More so, the Energy Commission of Nigeria has also included coal as one of the major contributors in its national energy master-plan projections for 2030 [Sambo, Iloeje, Ojosu, Olayande, Yusuf, 2006].

As such, with the present awareness level on global warming, this wake up call on the Nigerian coal power station is not without challenges. The principal challenge is the need to use coal in a more environmentally responsible manner to generate electricity while curbing the threats of global warming. Having studied the current FGN campaign for the revival its coal power industry, in critical view it is lacking in respect of environmental integrity. Thus the need *“to secure credible investors with the capability and commitment to develop coal based power generation, in view of Nigeria's significant supply gap in the power sector”* has to be appraised in the light of global warming [MSMD, 2006; BPE, 2006].

**The question that readily comes to mind with this need is: what should the government's requirements for limiting GHG emissions from such industry (coal power plants) be? It is therefore necessary to research into the future of the Nigerian coal power stations with the present reality of global**

**warming in assuring a sustainable environment.** Although the present “Nigeria’s national policy on environment reflects the country’s subscription to the concept of sustainable development” - [MOE, 2003] following Nigerian’s first national communication under the UNFCCC, the government is yet to formulate specific policy requirements that will limit the emission of GHGs from its coal-based power generating stations.

With this in mind, the research study will highlight the economic implications of using Nigerian coal to generate electricity in an environmental responsible manner. The outcome of this research will serve as a guide for the government, coal companies and investors to take legislative and investment decisions in this energy sub-sector. It will also promote the reduction of air pollution, carbon dioxide emission and its attendant global warming threats while ensuring a sustainable environment.

### **1.3 Research Aim and Objectives**

This research study will focus on the need to expand the knowledge of the Nigerian coal power stations future with respect to global warming threats. In view of this, the environmental impact and economic implication of ‘new’ coal based power generation development prospects in Nigeria will be appraised. This study seeks to basically establish a framework for controlling CO<sub>2</sub> emission from local coal power stations, while adapting the industry to the provisions of Kyoto protocol vis-à-vis clean coal utilization.

To achieve the outlined aim and objectives, the following shall be done:

- Determine the current level of GHG emissions in the existing coal power stations in Nigeria and compare the GHG emission levels to international standards (Kyoto protocol) on GHG emission cut back
- Analyse the economic future of the industry with cognizance to global warming implication and
- Finally propose a way forward for the Nigerian coal power stations in the light of global warming

The outcome of this research will further be useful in making recommendations that will serve as a guide in the choice of applicable clean coal technologies for coal-based power generation in Nigeria. As such, this dissertation also hopes to contribute to the definition of the Nigerian coal future.

## **1.4 Research Scope**

This research work will only evaluate already developed technologies for clean coal utilization applicable to power generation. It will not go into the chemistry of coal and carbon dioxide given off in the combustion of coal. Also, it will not be focused on new technology development; as such the economic analyses done were based on available technical data and technology capabilities.

## **1.5 Research Outline**

Chapter one serves as an introduction to the research study. It gives an overview of the research background and motivation for choosing the research theme, Nigerian coal power stations: its future in the light of global warming. It also clearly outlines the problem statement with aim and objectives of the research study while providing hints on the solution sought. It presents a brief overview of the following chapters and their respective contents.

Chapter two of this research study presents a review of different literatures that discuss the research problem. The focus is on global warming and greenhouse gas (GHG) emission issues with emphasis on carbon dioxide emission from coal-fired power generating stations. It further discusses coal developmental history and regulations, clean coal technologies and other GHG emission control efforts.

In chapter three, the research methodology used in gathering data on the research problem was extensively discussed. It showed the empirical work approach used in evaluating the future of the Nigerian coal power stations. It also presented the action plan for the verification and validation of the study results.

Chapter four presents and discusses all the relevant data and information gathered in the process of the research study with a full analysis of them. Finally, in chapter five conclusions were made based on the results of the analyses and subsequently recommendations are made based on the conclusions drawn.

## **CHAPTER TWO**

### **LITERATURE REVIEW**

## **2.1 Global warming**

### **2.1.1 Introduction**

Following the need for sustainable development, the world system is seriously changing over time as it relates to its environment and development. The discovery of climate change by Nobel prize laureate Svante Arrhenius in 1896 was a major breakthrough in the pursuit of sustainable development ideals. However, the political concern for a changing climate arose much later in 1985 at an “International Conference held on the Assessment of the Role of Carbon dioxide and other Greenhouse Gases on Climate Variations and Impacts” in Villach, Austria. This conference was organized by the World Meteorological Organization (WMO), United Nations Environment Programme (UNEP) and the International Council for Science (ICSU) [Elliot, 1998; WMO, 1986; Franz, 1997].

Before the Villach conference, there had been on-going discussions about global climate change controversies, which mainly focused on whether we were experiencing global warming at all or not. But later the dimension of the argument turned into whether the global climate change is a natural course or something that is human induced. However, today there is an understanding of the fact that activities of humans can affect, and has affected, the global climate system thus the raging global warming threats [WMO, 1986; IPCC, 2001].

## **2.1.2 What is global warming**

Global Warming is perhaps the most significant environmental problem facing the world today. Global warming is simply an overall warming of the earth, based on average temperature over the entire earth surface [Jeantheau, 2007]. It “comprises of an increase in the average temperature of the atmosphere, oceans, and landmasses of earth due to greenhouse effect”. Global warming is only an aspect of the global climate change challenge. Other variables such as rainfall, humidity and wind patterns form part of the climate system and they are also likely to change with an increase in the average earth’s surface temperature.

## **2.1.3 Causes of Global Warming**

Scientists generally believe that the earth’s temperature has been rapidly increasing. This is due to the activities of mankind on its environment since the 19<sup>th</sup> century Industrial Revolution era that led to heavy industrialization. [Bentley & Bersano, 2007; EPA, 2006]. Global warming is basically caused by the phenomenon known as the greenhouse effect. Certain gases (GHGs) in the atmosphere behave like glass in a typical greenhouse. They allow sunlight through to heat the earth’s surface but trap some of the heat from the sun as it tends to radiate back into space. These gases are called GHGs because of their ability to trap heat energy. They include carbon dioxide (CO<sub>2</sub>), methane (CH<sub>4</sub>), water vapour, nitrous oxide (N<sub>2</sub>O), sulphur hexafluoride (SF<sub>6</sub>) and fluorocarbons (CFC, PFC, HFC). [Miller GT, 1996; UNFCCC, 2006]

### **2.1.3.1 The Basic Science of Global Warming**

The “greenhouse effect is defined as the transmission of short-wave solar radiation by the atmosphere coupled with the selective absorption of longer-wavelength terrestrial radiation, especially by water vapor and carbon dioxide” – [Bentley & Bersano]. According to this definition, the incoming solar energy reaches the earth surface as short-waves and is radiated back into the atmosphere as long-waves. But the presence of greenhouse gases in the atmosphere causes most of the outbound long waves to be absorbed. The trapped energy due to the absorbed long waves are later given off and re-absorbed back by the earth thereby increasing the earth’s mean surface temperature [Bentley & Bersano, 2007].

Going by Al Gore’s illustration, “the sun’s energy enters the atmosphere in the form of light waves and heats up the earth surface. Some of that energy warms the earth and is then radiated back into space in the form of infrared waves”. Following this illustration under normal circumstances, a portion of this outgoing infrared (heat) radiation is being trapped naturally in the atmosphere. However, this occurrence is a good thing because it helps in keeping the earth’s temperature within a comfortable range for the support of human life [Gore, 2006]. The figure 2.1 shows how the solar radiation from the sun gets into the earth through the atmosphere and also how part of the radiation is being trapped thus effectively defining the greenhouse effect.

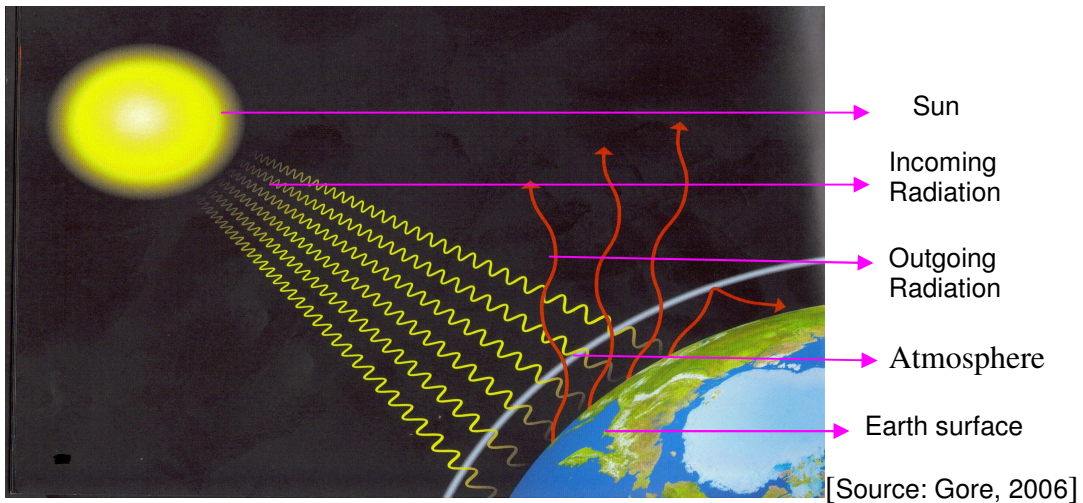

Figure 2.1: Pictorial illustration of the Normal (healthy) Greenhouse Effect

But with excessive quantities of GHGs in the atmosphere, the normal thin layer of the earth's atmosphere (as shown in figure 2.1) is thickened thereby causing more of the heat radiation entering the earth atmosphere to be trapped. This build-up of heat energy increases the average temperature on the earth surface thus resulting in global warming. The thickened atmosphere with the resultant increased heat re-absorption effect of the earth is shown in the figure 2.2 below.

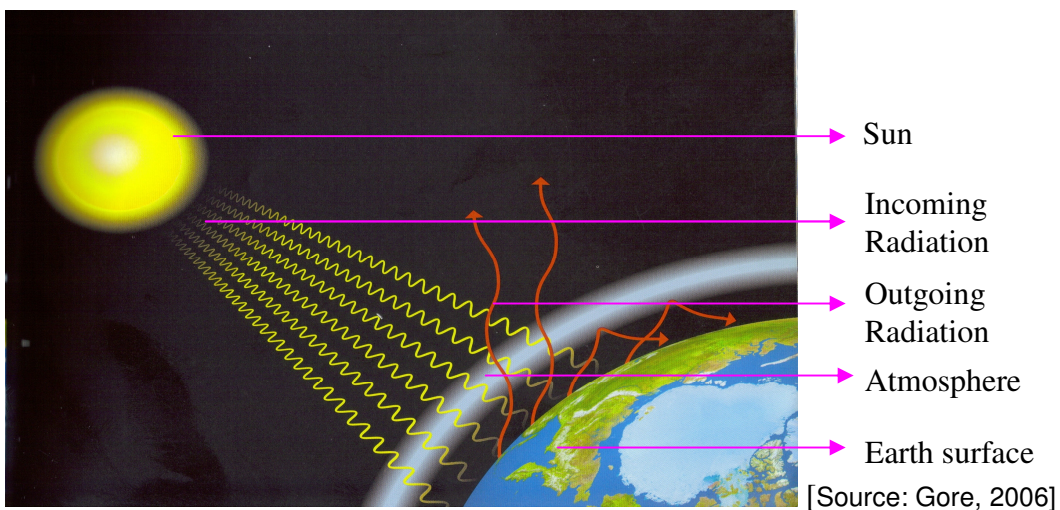

Figure 2.2: Pictorial illustration of Excessive (abnormal) Greenhouse Effect.

### **2.1.3.2 CO<sub>2</sub> as the Main Contributor**

With increasing concentration of GHGs in the atmosphere the natural balance of the earth's temperature mechanism is distorted (skewed) towards a continual temperature rise. Of all the greenhouse gases identified, CO<sub>2</sub> contributes the most to the threat of global warming due to anthropogenic activities. But CO<sub>2</sub> does not have the highest global warming potential (GWP) over a time period; it is the most abundant human-induced GHG found in the atmosphere. GWP is the average radiative forcing impact of a unit mass of any particular GHG emitted relative to a reference, usually CO<sub>2</sub>. [Lee, 1996; Bentley & Bersano, 2007; EPA, 2008; EPA, 2002]. Arguably, the main source of this CO<sub>2</sub> in the atmosphere is from the combustion of fossil fuels like coal, oil, and natural gas. According to Bentley & Bersano, "burning of fossil fuels globally releases billions of tons of carbon dioxide into the atmosphere each year". CO<sub>2</sub> contributes about 60% of the total greenhouse effect [Manchester, 2007].

According to Bentley & Bersano "CO<sub>2</sub> is the second most abundant greenhouse gas following water vapor which occurs most naturally in the atmosphere". But CO<sub>2</sub> also occurs naturally in the atmosphere, soil, carbonate rocks, and ocean water. In addition, other natural sources through which CO<sub>2</sub> is released into the atmosphere include animal respiration and decay of organic matter.

Subsequently, part of the "CO<sub>2</sub> is removed from the atmosphere when it is dissolved in ocean water or absorbed by plants through photosynthesis" [Bentley & Bersano, 2007]. Thus a natural balance (carbon cycle) is maintained by nature

to ensure that excess CO<sub>2</sub> in the atmosphere is controlled by photosynthesis and ocean absorption of CO<sub>2</sub> [Keepin, Mintzer, Kristoferson, 2007; EPA, 2008]. Through observation, according to Bentley & Bersano of St Francis, “over the past few hundred years humans have released CO<sub>2</sub> into the atmosphere at a much faster rate than that which the earth’s natural processes” (carbon cycle) can handle. Atmospheric CO<sub>2</sub> concentration has been reported to “increase by about 1.5 ppm per year”. This alarming increase in “carbon dioxide concentration enhances the heat-trapping capacity of the earth’s atmosphere” hence causing more global warming yearly [Bentley & Bersano, 2007; EPA, 2006; EIA, 2006].

### **2.1.3.3 Measuring the Atmospheric CO<sub>2</sub>**

From the late 1950s scientists recognised the increasing concentration of CO<sub>2</sub> in the atmosphere as a need to set up observatories, in order to trend the increase per year [Gore, 2006]. Since then, “the composition of the atmosphere has been carefully monitored” – Bentley & Bersano. It is clear from the study that the concentration of GHG is increasing yearly. “The atmospheric CO<sub>2</sub> levels have already increased by nearly 30% since the Industrial Revolution” [Bentley & Bersano, 2007]. As such without any proper regulation, the CO<sub>2</sub> concentration is bound to increase from 30 to 150% of the current levels [EPA, 2006].

The “concentration of atmospheric carbon dioxide has increased by 75 ppm since 1850” [Lutgens & Tarbuck, 2002]. “According to predictions, the atmospheric CO<sub>2</sub> concentration will reach 600 ppm by the second half of this twenty-first century. Climate models predict that this rapid increase in

atmospheric CO<sub>2</sub> will produce a consequent 2.5°C increase in average earth surface temperature” [Bentley & Bersano, 2007].

The study so far “shows an increase in both atmospheric CO<sub>2</sub> concentration and average earth surface temperature”. This buttresses the reason why “scientists wondered if there was no direct causal relationship between the rising atmospheric CO<sub>2</sub> concentration and global warming”. Although “many scientists still debate the real cause of global warming, but the Intergovernmental Panel on Climate Change (IPCC) concluded in 2001 that global warming is caused primarily by human activities that increase the atmospheric concentrations of CO<sub>2</sub>”. Therefore, this substantiates the need for proper monitoring of the atmospheric CO<sub>2</sub> concentration. [IPCC, 2001; Bentley & Bersano, 2007]

#### **2.1.4 Effects of Global Warming**

Science has established that the global warming phenomenon as a reality. However; it is presently a complex situation to predict how exactly increasing carbon emissions and the consequent global warming issues will impact on our environment in the future. There are computer models for predicting the future effects of global warming and they show that the increasing CO<sub>2</sub> concentration in the atmosphere will eventually lead to more climate change issues following temperature rise. “In any region, the predicted effects of global warming will accelerate the rate of climate change and ultimately pose threat to life on Earth.” [Bentley & Bersano, 2007; EPA, 2006; Bolin, Jager, Doos, 2007]

The predicted effects of global warming are as follows:

- Increasing incidence of droughts and flooding of coastal areas
- Rising ocean temperatures and sea levels
- Increased severe cyclones occurrence such as tornadoes and hurricanes
- Melting of glaciers and reduction of mountains snow cover
- Dying coral reefs and drying up of lakes
- Coastal erosion and the eventual loss of coastal ecosystems.
- Alterations in crop and food production
- Spreading of diseases to places not previously present

Already the evidences of some of these outlined effects are not far-fetched. The snow covers on Mount Kilimanjaro have melted over the last 30 years to a point where it is feared that in the next 10 years, the whole snow cover will be gone. Also, the Lake Chad has shrunk to a scaring one-twentieth (1/20) of its original size over the last 40years [Gore, 2006]. “It is estimated on the basis of observed changes since the beginning of this century, that global warming of 1.5 °C to 4.5 °C would lead to a sea-level rise of 20 to 140 centimeters” [WMO, 1986; Scope29, 2008]. However, the trend shows that the rising average temperature will be more towards the poles and less within the tropics. We will also experience more global warming in the winters than summer seasons.

### **2.1.5 Controlling Global Warming**

According to Bentley & Bersano of St Francis, “once carbon dioxide is released into the atmosphere, it has the ability to remain there for more than a century

before being naturally recycled". As such the effort of mankind should be safeguarding the future of our ecosystem. Therefore, we must at the interim "plan for the possible effects of the current concentration of atmospheric CO<sub>2</sub> and subsequently devise methods to reduce the rate at which the CO<sub>2</sub> is being emitted" in the future. According to Kyoto protocol developed countries are obliged to reduce their GHG emission levels while other developing countries will have to work along in achieving this goal. "Industrialized nations should aim for a 20% reduction in CO<sub>2</sub> emissions by the year 2010" [Bentley & Bersano, 2007].

One important innovation in the global warming mitigation efforts is "the introduction of GHG emission trading through which companies, in conjunction with government, agree to cap (limit) their emissions or to purchase credits from those operating below their allowances" - Wikipedia. This is an offshoot of the world's primary international agreement on combating global warming, the Kyoto protocol: an amendment to the United Nations Framework Convention on Climate Change negotiated in 1997. [UNFCCC, 1998; Wikipedia, 2007]

"CO<sub>2</sub> emissions have been controlled in some countries with the use of heavy energy use taxes". All the countries are working towards "increasing energy efficiency, promoting alternative energy sources, and effectively cutting down GHG emission. In the United States, the Energy Star program rewards consumers who buy energy efficient appliances." [Bentley & Bersano, 2007]

## **2.2 Coal**

### **2.2.1 Coal utilization History**

According to the World Coal Institute WCI, “coal is the altered remains of prehistoric vegetation that originally accumulated in swamps and peat bogs”. Coal is physically and chemically a heterogeneous rock that consists mainly of organic materials (macerals) with inorganic materials (minerals) interspersed. Coal is a combustible rock that basically consists of carbon, hydrogen, nitrogen, sulphur, ash and oxygen. “Coal has a very long and varied history”. Some historians believe that coal was first used commercially in China for smelting copper and for casting coins around 1000 BC. [WCI, 2008; Lee, 1996]

Coal is one of the most abundant, available, affordable, reliable and geographically well-distributed energy resources. It is also easy and safe to transport subjecting it to many important uses worldwide. Over the years coal has been significantly used for electricity generation, steel production, cement manufacturing and other industrial processes. According to WCI, “other important users of coal include alumina refineries, paper manufacturers, chemical and pharmaceutical industries”. The merit of coal usage is such that several other chemical products can be derived from the by-products of coal processing. In spite of these benefits, some of the issues with coal are related to mine safety, labour availability, water availability, feedstock transportation, mine equipment, capital and wastes control. [WCI, 2008; Smoot & Smith, 1995]

The Industrial Revolution experienced in the 18th and 19th centuries led to the expanded use of coal. During these periods there were many industrial breakthroughs driven by coal: “the improvement of the steam engine by James Watt, patented in 1769, iron and steel production, rail transportation and steamships” - WCI. Another major achievement was the generation of steam through coal-fired boilers used for generating electricity. As a result of this later feat “coal’s future became closely tied to electricity generation”; figure 2.3 below shows the demand for coal used for electricity generation.

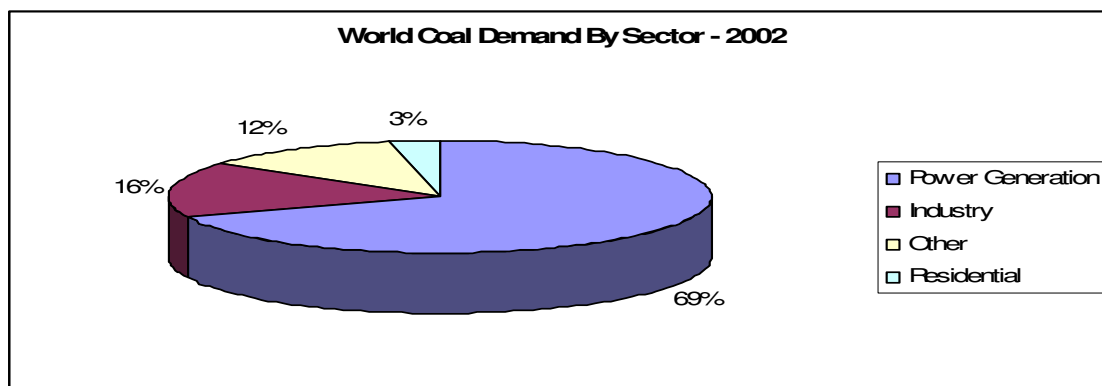

Figure 2.3 World’s coal demand for power generation [Source: IEA, 2004]

According to WCI, “The first practical coal-fired electricity generating station, developed by Thomas Edison, went into operation in New York City in 1882, supplying electricity for household lighting”. Today coal is responsible for about 40% of electricity generated around the world. However in some countries, coal holds a higher percentage of their total electricity generated: “Poland relies on coal for over 94% of its electricity; South Africa for 92%; China for 77%; and Australia for 76%”. With this kind of trend, coal would likely remain the most affordable fuel for power generation in many developing and industrialized countries for several decades. [Miller BG, 2005; WCI, 2008; ESKOM, 2007]

## **2.2.2 Coal Usage and Environmental Regulation**

Coal having played a significant role in the advancement of civilization and industrialization following its exploits during the Industrial Revolution, has also passed through several phases of environmental challenges. The increased demand for coal contributed to issues like acid mine drainage (AMD), fugitive dust emissions, release of harmful gases and respiratory ailments in line with mining activities. Other environmental issues are related to activities linked with coal preparation, transportation and combustion. These various issues have led to legislations made to protect the environment against their negative impacts. These regulations vary with different countries but they all border on the conservation of air, land, surface and underground water integrity. Environmental protection has always been an evolving area; several reviews are done as time progress in ensuring environmental sustainability. [Miller BG, 2005]

### **2.2.2.1 Coal-fired Power stations**

Since the development of electricity, its demand has been on the rising slope, this is partly because of the ease of the conversion of electrical energy into other forms of energy useful to mankind. About 40% of the electricity generated worldwide is derived from coal power stations. A distribution of the world's electricity generation by fuel type is shown in figure 2.4; it shows the percentage contributed by coal in the base year and a projection for 2030 [IEA, 2004].

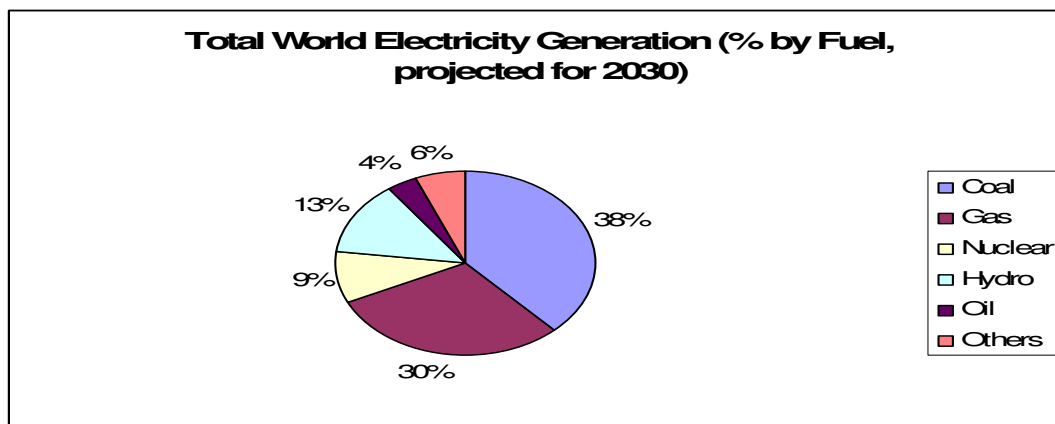
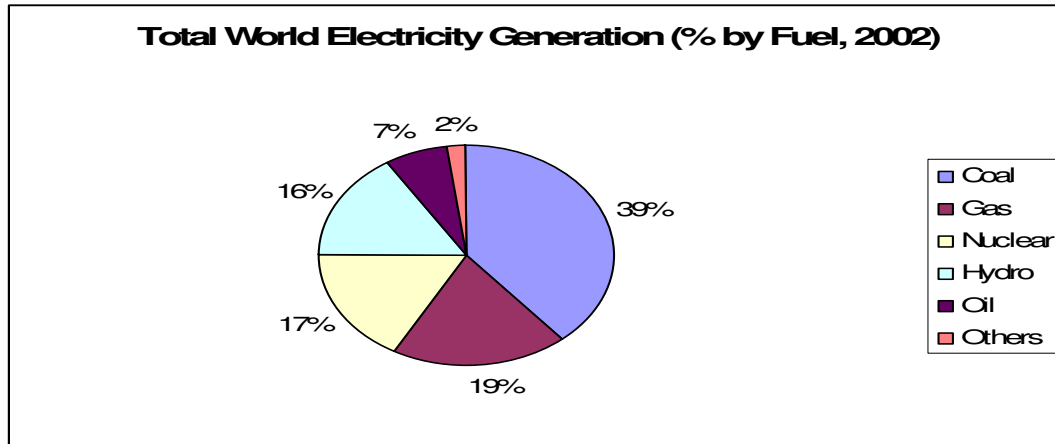

Figure 2.4 World Electricity Generation by Fuel type [Source: IEA, 2004]

Globally, coal is preferred for power generation because it is relatively cheaper than other fossil fuel options. The figure 2.5 shows the price variations of fossil fuels and coal's competitive cost advantage with respect to time. Also with concerns about the safety of nuclear plants, the unstable cost and supply problems of oil and gas, most economies still favour their coal resource for power generation. Most of the coal power stations use steam turbines in which high pressure steam generated from pulverized coal boilers, spin the turbines that drive the generators. The efficiency of electricity generation from typical pulverized coal fired plant ranges from 35 – 40%. [Lee, 1996]

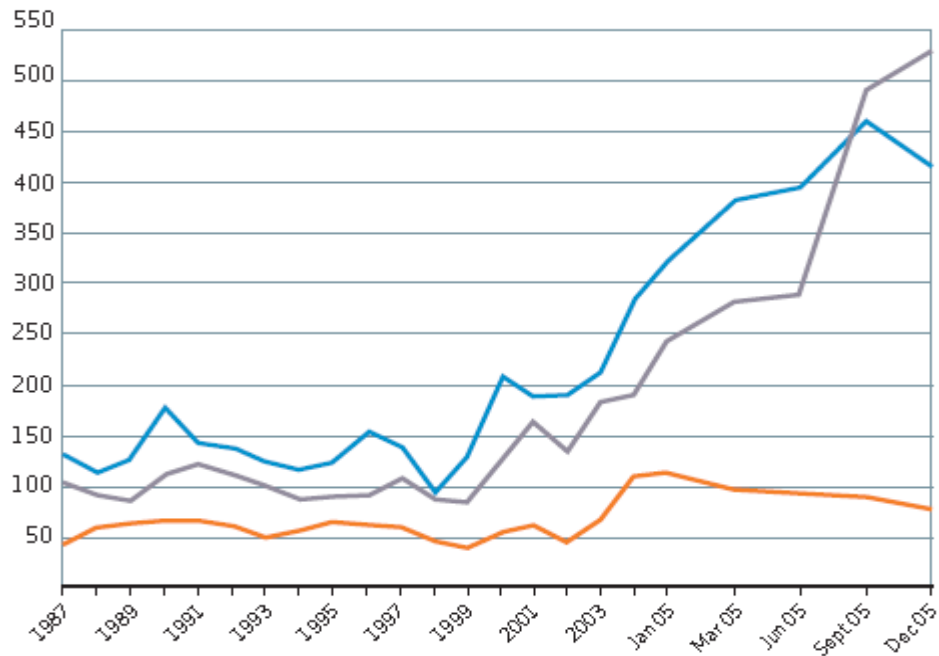
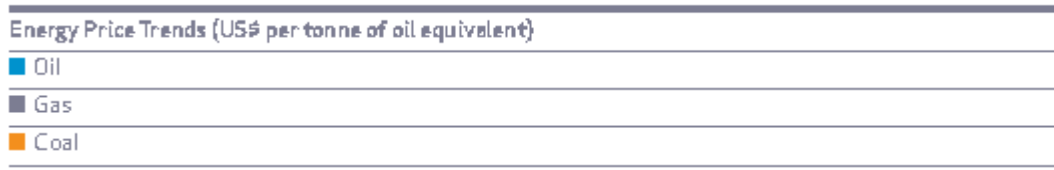

Figure 2.5 Energy Price Trends of Oil Vs Gas Vs Coal (US \$ per ton of oil equivalent) [Source: BP as cited in WCI, 2008]

Whereas coal makes an important contribution to economic and social development worldwide, its environmental impact has been a major challenge. The combustion of coal for power generation purposes leads to the release of environmental pollutants, such as oxides of sulphur and nitrogen (SO<sub>x</sub> and NO<sub>x</sub>), particulate matters and trace elements, like mercury. This has been the lingering challenge of the coal power stations until the growing concerns about global climate change became an added dimension to the environmental impact evaluation of coal stations.

Following recent studies, CO<sub>2</sub> which is also emitted from the combustion of coal has been established to be a causal part of the carbon imbalance leading to global warming. CO<sub>2</sub> consists of about 15% by volume of the flue gas being emitted from pulverized coal fired power stations using air for its combustion. [WCI, 2008; Figueroa, Fout, Plasynski, McIlvried, Srivastava, 2007]

Already there are available technologies that have been developed and deployed to minimise the emissions of sulphur and nitrogen oxides, particulate matters and trace elements from coal power stations. Typically we have the flue gas desulfurization (FGD) system, design of low NO<sub>x</sub> boilers (LNB) and electrostatic precipitators (ESP) to take care of SO<sub>x</sub>, NO<sub>x</sub> and fly ash emissions respectively.

As it were today, the only issue as regards these emissions has been the downward review towards achieving very minimal amounts of these pollutants in the environment. This trend has engendered continuous technology improvement efforts. In the USA for example, the development of air pollution legislation and regulatory acts occurred from 1955 to 1970. Since then, their Clean Air Act Amendments of 1970 has been reviewed severally. There were a few regulatory changes made in the 1980s, 1990 brought significant regulatory changes and “in 2003 the Environmental Protection Agency (EPA) proposed a rule to permanently cap and reduce mercury emissions from power plants” [Miller BG, 2005; WCI 2008b]. The table 2.1 below shows the emission standards set different countries to reduce emissions of particulate matters, sulphur and nitrogen oxides from their coal-fired power plants.

Table 2.1 Range of National emission standards for particulates, SO<sub>2</sub> and NO<sub>x</sub> (mg/m<sup>3</sup>) for new coal-fired plants

Country	Particulates	SO <sub>2</sub>	NO <sub>x</sub>
<b>Current</b>			
Australia	65-210	—	535-860
Austria	50-150	200-1620	200-500
Belgium	50	250-2000	200-800
Canada	125	715	740
Czechoslovakia	100-250	500-2500	650
Denmark	40	400-2000	200-650
EEC	50-100	400-2000	650-1300
Finland	430-570	380-1270	135-405
France	50-100	400-2000	650-1300
FRG	50-150	400-2000	200-1500
Italy	50	400-2000	200-650
Japan	50-300		205-980
Netherlands	50	200-700	100-650
New Zealand	105	1255	2005
Poland	190-3700	540-2890	95-705
Spain	50-100	400-2000	650-1300
Sweden	35-50	160-270	80-540
Switzerland	55-160	430-2145	215-535
Taiwan	25-500	2145-4000	720-2050
Turkey	140-235	430-1875	750-1690
UK	50-300	400-3000	500-650
USA	40-125	740-1480	615-980
<b>Proposed</b>			
Finland	60	—	—
FRG	150	—	—
Netherlands	20	—	—
Switzerland	—	430	—
Taiwan	—	1430	—
USA	60	—	—

[Source: Lee, 1996]

From the table above, it could be seen that different countries set their own emission limits, however this approach undermines the fact that atmospheric transport of pollutants is not bounded by geographic boundaries. Thus, there is a great need for international harmonization.

On the other hand, the need to control global warming is currently placing a hard look on the coal-fired power stations because of the amount of CO<sub>2</sub> emitted. According to the International Energy Agency and as discussed by Berlin & Sussman of the center for America progress, “the ever-rising industrial and consumer demand for more power in tandem with cheap and abundant coal reserves across the globe are expected to result in the construction of new coal-fired power plants producing 1,400GW of electricity by 2030”. Therefore “in the absence of GHG emission controls, these new plants will increase worldwide annual emissions of carbon dioxide by approximately 7.6 billion metric tons by 2030” [Berlin & Sussman, 2007]. The way forward is to find viable means of reducing GHG emissions from already existing and intended new coal plants, which this dissertation pursues.

### **2.2.3 The Future of Coal Power stations**

“A sustainable energy future is one where the society’s energy needs are met using available resources over the short, medium and long terms” - WCI. In other words, this implies utilizing all the available energy sources in such a manner that reduces negative impacts on the environment and maximizes economic and social benefits. It is because of this need that much stricter environmental regulations and environmentally acceptable or friendly utilization of coal has become more important than ever. As established already the environmental impact of electricity generation from coal is a concern for mankind. “The challenge for coal as well as all other fossil fuels is to reduce greenhouse gas

and other emissions, while continuing to make major contribution towards global development and energy security”. [WCI, 2008a; WCI, 2008b]

According to Hawkins, his submission on coal and global warming to the United States Senate Energy Committee argues seriously that “the future of the US coal in the electric power sector is uncertain”. According to him, the reason for “this uncertainty is the government’s failure to define future requirements for limiting GHG emissions, especially CO<sub>2</sub>”. This argument is in line with the problem statement outlined in this study and provides a good baseline for empirical investigation and further discussion made in this dissertation.

Furthermore, “coal as a fossil fuel has the highest uncontrolled CO<sub>2</sub> emission rate and coal power plants are expensive, long-lasting investments”. As such, “Key decision makers need to understand that the problem of global warming has to be addressed within the time frame needed to recoup investments in power projects presently in their planning stage”. Hawkins also alleges that “since the status quo is unstable and future requirements for coal plants and other emission sources are inevitable but unclear, there will be increasing hesitation to commit the large amounts of capital required for new coal projects”. Part of his claims is that “coal’s future as an option for generating electricity will be determined in large part by how the society responds to the problem of global warming”. Also, “40% of United States CO<sub>2</sub> emission comes from electric power generation, the largest source of global warming pollution in the United States”. [Hawkins, 2005; Coal Conference, 2008]

Whereas according to an environmental agency in the United Kingdom, coal-fired power generation has historically provided much of the UK's electricity. However, the proportion has declined in recent years as gas has become more available and cheaper, though there have been significant short-term fluctuations. Today, electricity generation from coal provides about 30% of the UK's power demand. European legislation requires coal-fired power plant to meet more stringent emission limits by January 1, 2008. Because of this, operators of power plants have recently invested about £575 million in new abatement plant that reduces sulphur dioxide (SO<sub>2</sub>) emissions. Following this effort, existing plants for which it is uneconomical to fit the new abatement technology may operate only until 2016. With this constraint, out of the current 28 Gigawatts-equivalent (GWe) of coal-fired generating capacity, 8.5 GWe will therefore be lost. As a way of adapting to the future demands, operators have developed proposals for building new plants to replace those that will be closed down. The new plants will have to meet more stringent environmental standards right from their commissioning and also be able to meet future requirements, such as carbon capture and storage (CCS) to minimize global warming. [Howe, 2007]

For the last 15 years, most of the new power plants built in Nigeria have been fueled with natural gas [Nyajo, 2004]. Today, however, coal is again emerging as a fuel of choice for the Nigerian power sector following the federal government's campaign for the expansion of the electricity generation. Nigeria has "proven coal reserves of 639 million metric tons while the inferred reserves are about 2.75 billion metric tons" [NCC, 2007] *see Appendix B for Nigerian coal and lignite*

*deposits*. According to the Energy Commission of Nigeria (ECN) coal will be responsible for 6.93% of the estimated future installed electricity generation capacity of the country by 2030 [Sambo et al, 2006]. This implies about 2.2GW of electricity derived from coal-fired power stations and approximately an additional 12 million metric tons of CO<sub>2</sub> emission in the absence of emission controls.

Presently, the total installed coal capacity is 30MW (Oji river power station) of electricity, of which the output is zero. The last effort at rehabilitating the Oji river coal-fired power station got the plant running at about 10% of its designed capacity owing to many technical and financial challenges [Iwuagwu, 2004].

Considering the fact that global warming is a concern, and that coal-fired power stations emit the most CO<sub>2</sub> of all the fossil fuel plants; the future of new coal power stations in Nigeria has to be surveyed carefully. Chimere Ikoku in his keynote paper on coal in the Nigerian energy mix calls for research efforts to be focused on improved non-polluting utilization of coal as a means of ensuring its enhanced future use [as cited in Okolo & Mkpadi, 1996]. Except proper definitions and efforts are made on how to regulate GHG emissions from coal plants, the environment will be in serious jeopardy due to global warming issues.

'Business as usual' can no more be the case for coal fired power stations because of the need to adjust 'positively', in order to mitigate global warming. The new outlook is to find favourable economic means of utilizing coal for power generation while minimizing greenhouse gas emissions.

## 2.2.4 Clean Coal Technologies

Increasing atmospheric concentration of carbon dioxide is a global problem and will require a global effort to address it. According to White et al, there are about three options of stabilizing the atmospheric levels of greenhouse gases:

- increasing energy efficiency,
- switching to less carbon-intensive energy source,
- and carbon sequestration.

[White, Strazisar, Granite, Hoffman, Pennline, 2003]

Of these three approaches, only two are favourable to coal derived energy: increasing energy efficiency and carbon sequestration. But increasing energy efficiency requires both demand and supply side efforts.

Improvement of energy efficiency from the demand-side entails encouraging consumers to use energy efficient appliances and also to use power more conscientiously. Part of such efforts is the substitution of regular incandescent bulbs with energy saving lamps. In the USA, their Energy Star Program rewards consumers for opting for energy efficient systems. [Bentley & Bersano, 2007]

However from the supply-end, improvement of energy efficiency means improving the power plant generally. Power plant efficiency is typically defined as “the amount of heat content in (Btu) per the amount of electric energy out (kWh), commonly called a heat rate (Btu/kWh)” [Bellman, 2007]. In other words, improving plant efficiency means decreasing the heat rate of the plant. This implies that less quantity of fuel will be used in generating each kWh output from

the plant. In a wider view, under large volumes, using less quantity of fuel in generating a given amount of electric power output (kWh) will mean cutting down on the emissions of the plant. Ultimately this will lead to lower emission rate per kWh generated. "Efficiency improvement is by far the most predictable and lowest cost method to reduce all emissions, including that of carbon dioxide from coal stations". The application of advanced steam parameters (supercritical and ultra-supercritical cycles) enhances environmental performance of a pulverized coal plant [Kraemer & Beck, 2006].

Power plant efficiency improvement is mainly achieved by the substitution of old plants with new plants that have better efficiencies. As such, the efficiency of a new power plant is largely a function of economic choice. Efficiency improvements can have broader impacts than simple monetary gains for the plant operator. Power plant efficiency estimates for coal technology ranges from 7,757 – 9,275 Btu/kWh (44% - 37% efficient HHV). Some of the factors affecting the efficiency of a power plant include design choice, operational practices, fuel quality, pollutant control, ambient conditions. [Bellman, 2007]

#### **2.2.4.1 Carbon capture and Sequestration (CCS)**

The energy efficiency improvement options for reduction of carbon dioxide emission achieve 10 – 15% CO<sub>2</sub> reduction rates. However, to achieve CO<sub>2</sub> reductions beyond those accomplished by higher efficiency systems, CO<sub>2</sub> would need to be removed directly from the flue gas streams. This scheme is otherwise called carbon capture. The carbon capture and sequestration technology

requires that CO<sub>2</sub> be captured from flue gas streams, concentrated, and compressed for transportation to a safe storage and sequestration location [Kraemer & Beck, 2006]. Figure 2.6, below shows the illustration of how the carbon capture and sequestration works.

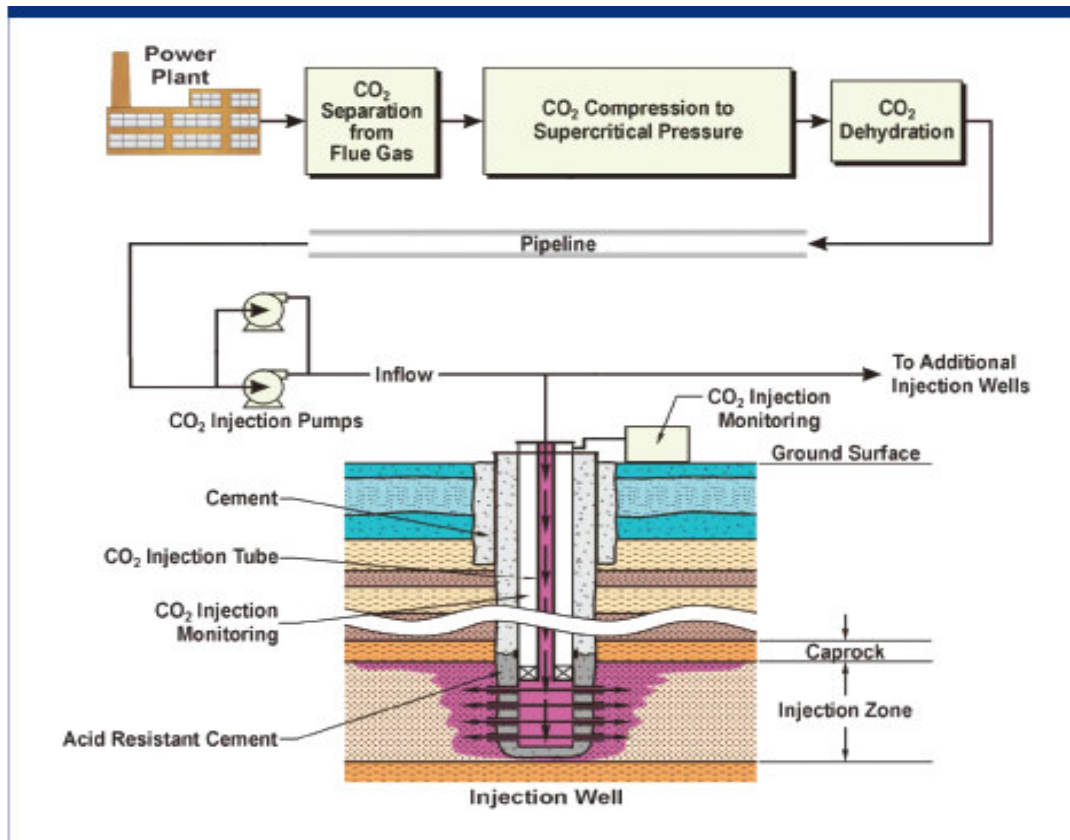

Figure 2.6 Carbon Capture and Sequestration Scheme [Source: as cited in Berlin and Sussman, 2007]

The geological formations (sequestration location) “that typically receive the most consideration as potential hosts for CO<sub>2</sub> storage are depleted petroleum (oil) reservoirs, deep unmineable coal seams, and deep saline aquifers. Also, formations such as depleted and depleting gas reservoirs, salt domes, salt formations, depleted CO<sub>2</sub> domes, carbonaceous shales, and others are potential CO<sub>2</sub> host formations”. But sequestration in coalbeds has this additional

advantage of yielding a value-added product, Methane (CH<sub>4</sub>) [White et al, 2003]. Appendix C shows the potential CO<sub>2</sub> sequestration sites in Nigeria.

The implementation of carbon capture and sequestration (CCS) involves the addition of separate devices or equipment to the existing plant. Commercially available technologies for CCS can capture up to and over 90% of the CO<sub>2</sub>. But typically they are capital intensive and impose energy efficiency penalties due to electric power output reduction (significant parasitic power loss). The costs for carbon capture today for all coal technologies are substantial and would increase the cost of electricity generated significantly. [Kraemer & Beck, 2006]

Some of the available CO<sub>2</sub> capture technologies include: use of Amine scrubbing system; use of chemical absorption media (caustics, amino acid salt solutions); use of physical absorbents (selexol, rectisol). Others are chemical adsorption processes of carbonation-calcination reactions (CCR) of high reactivity metal oxides; use of physical adsorbents (zeolites, activated carbon); use of organic and inorganic membranes; chemical looping, cryogenics and oxycombustion. [Jones, 2007]

Other viable technologies that enhance power generation from coal with low carbon dioxide emission are integrated gasification combined cycle (IGCC), fluidized bed combustion cogeneration (FBC), magnetohydrodynamic (MHD) topping cycle and underground coal gasification (UCG). [Lee 1996; Eskom 2007]

## **2.2.5 Conclusion**

From the literature surveyed so far, it is glaring that the issue of global warming has become a new way of evaluating our energy systems. The combustion of coal emits carbon dioxide which if uncontrolled helps in compounding the on-going greenhouse phenomenon. The idea of sustainable development makes it imperative that the use of energy sources has to be economically, socially and environmentally balanced. Therefore, any future use of coal has to conform to this ideal, however, finding cost-effective means of ensuring the sustainable use of coal is still a challenge. Technical feasibilities and cost indicators exist for different technologies used for reducing the emission of CO<sub>2</sub> from coal plants.

In Nigeria the need exists to survey the economic implications of adopting and implementing any of the existing mature CCS technologies as a means of demonstrating a sustainable development of its coal based power generation. However, the selection of new generation technologies will depend on many factors, such as: capital and operating costs, overall plant energy efficiency, fuel prices, selling cost of electricity (COE). Others are availability, reliability and environmental performance, current and potential regulation of air, water, and solid waste discharges from the coal power plants. This dissertation will attempt to fill in this gap in determining the future of Nigerian coal stations in the light of global warming. The next chapter, three, presents the empirical investigation methods applied in adopting and implementing GHG emission control in Nigerian coal power stations.

**CHAPTER THREE**  
**EMPIRICAL INVESTIGATION**

### **3.1 Research Methodology**

This chapter presents the research design and methodology applied in the study of the research problem. The data collected in the course of this research will be presented and discussed in the next chapter, Results and Discussion.

#### **3.1.1 Research Approach**

The study of the future of the Nigerian coal power station in the light of global warming was done with the case study research method. This research approach surveys the future of the coal power stations by studying the prospects of the existing power stations with greenhouse gas mitigation. A case study of the Oji river coal-fired power station (the only existing Nigerian coal station) was used for this purpose. The economics of the greenhouse gas mitigation option will show a new cost of electricity (COE), used in ascertaining the economic competitiveness of the coal power option vis-à-vis other generation sources in Nigeria.

#### **3.1.2 Data Gathering**

This research dwelled on various sources for its study data collection. Most of the data gathered were derived from existing secondary data sources found in published textbooks, journals, government gazette, internet, technical papers, conference proceedings and articles.

The research field data were collected through visits to the Oji power plant and personal interviews conducted with key personnel of the Oji power station. Telephone contacts were used in making prior contacts and arrangements for the site visit and interview appointments.

### **3.1.2.1 CO<sub>2</sub> Emission Rate**

As stated in the literature review (section 2.2.3), the Oji power station is not generating power presently; as such the plant output is 0MW. To estimate the quantity of carbon dioxide (CO<sub>2</sub>) emitted from Oji plant:

- The plant was visited and the name plate of the installed boilers were obtained
- Literature sources were used to evaluate the quantity of CO<sub>2</sub> emitted from such boilers
- Live CO<sub>2</sub> data capture was made in a similar power station in South Africa (Sasol Secunda Steam Plant)

The CO<sub>2</sub> emission data of Sasol Secunda steam plant was collected by sampling the flue gas stream from the boiler (#4 of Unit 243) with a gas analyzer (Testo 300XL). This gas analyzer captures and indicates quantitatively the flue gas temperature and constituents; typically the quantities of CO<sub>2</sub>, O<sub>2</sub>, and NO, CO in percentage volume and ppm respectively are found. The sampling was done on an hourly interval for five times with the average value of the readings computed.

To assure the quality of data obtained with the gas analyzer, the analyzer was calibrated according to the manufacturer's specifications and trial readings taking from the ambient air to show its full functionality. Also, the sampled data was compared to the plant operators' performance logs to establish its correlation.

### **3.1.2.2 Oji Plant Specific Data**

Personal interview (face-to-face) was used in sourcing for plant specific data that were not obtainable from surveyed publications relating to Oji power station. The interview questions used were designed to be concise and clear. An introduction providing background information on the research study was given as guidance to respondents. Also, to ensure that respondents are not biased, the presentation of questions maintained a tone of neutrality.

The personal interview survey method affords the use of open ended questions as to customise situations, with ability to probe and clarify on questions in order to gather qualitative and quantitative information on technical characteristics, performance and site specific data. This survey method enhances the survey response rate, while giving room to obtain direct responses from key highly placed personnel of the power station.

The data sourced for through interviews include the Oji plant specific design and operation parameters such as:

- plant capacity factor,

- flue gas rate,
- designed plant life,
- fuel cost,
- plant heat rate,
- plant installation cost,
- boiler efficiency,
- applicable emission standards

To ensure the quality of data collected through the personal interview, follow-up verification telephone calls were made to check the respondents' answers. Also, the nameplates of applicable equipment in the plant were also sighted for clues. In addition, the original equipment manufacturers manuals were requested for, in order to confirm equipment design specifications.

### **3.1.2.3 CO<sub>2</sub> Capture and Sequestration Cost**

The cost of commercially available CO<sub>2</sub> capture and sequestration technologies were sourced from the internet and other literature sources. This includes the cost scaling factors for the application of the CO<sub>2</sub> emission control system to an existing power plant. To assure the quality of the data, the consistency of the data in the sources surveyed was checked. These sources include vendors, international energy organisations, research groups, and experts' opinion.

## 3.2 Economics of GHG Emission Control

In order to analyse economically the future of Nigerian coal power stations with global warming issues, the economics of reducing CO<sub>2</sub> emission with Amine-based capture system from the Oji power station is as shown in section 4.2 of the Result and Discussion chapter. The cost estimates for the investment/capital expenses, operation and maintenance costs, and fuel costs for the CO<sub>2</sub> emission control system were done using the Integrated Environmental Control Model (IECM-cs) cost model.

The Integrated Environmental Control Model, IECM-cs 5.2.2 © 2008 is a specialized power plant simulation model developed by Carnegie Mellon University for the U.S. Department of Energy and National Energy Technology Laboratory (NETL). “The IECM computer-modeling program performs a systematic cost and performance analyses of emission control equipment at coal-fired power plants”. It allows users to configure the plant to be modeled from a variety of pollutant control technologies. The history of the Integrated Environmental Control Model (IECM) is a long and successful one, dating back to its origin in the early 1980's. The model has been applied by hundreds of users for preliminary to detailed plant design. [Berkenpas et al, 2000]

The new cost of electricity derived from the implementation a CO<sub>2</sub> emission control system on the existing plant is calculated with the levelized annual cost method sourced from literature. This levelized cost of electricity for the retrofitted

coal power station will be compared (in chapter 4, section 4.3.1.2) to the cost of electricity generated from other baseload options in Nigeria.

### **3.3 Verification and Validation**

In order to assure the quality of the work done, the outcome of the research study process was subjected to thorough scrutiny by doing verifications and validation accordingly. These steps were applied; the GHG emission cut back achievable by the proposed (Amine-based CCS) solution was checked against the specifications of the Kyoto protocol. The merits of the solution are shown by referring to successfully implemented projects similar to the proposed solution. Also the adoption and implementation of the research outcome will be proposed to the appropriate ministries of the federal government of Nigeria as a means of testing the merits of the proposed solution.

Chapter four presents the results and discussion of the empirical investigation of this research study. It will show the analysis of the Oji river power plant CO<sub>2</sub> mitigation economics and its bearing on the future of the Nigerian coal power stations.

## CHAPTER FOUR

### RESULTS AND DISCUSSION

#### **4.1 Field Results**

##### **4.1.1 Case Study**

###### **Brief overview of Oji Power station**

Oji river power station is a coal-fired steam generating power plant, the only one of its kind in Nigeria. The power station was commissioned on February 9, 1956 by with (6No) six boilers and (4No) four steam turbines installed with a total capacity of 30MW. The power station was built under the British government which ended in 1960 when Nigeria gained its independence. [Iwuagwu, 2004]

The power station served to its designed capacity until the Nigerian civil war of 1967 – 1970 which marked the beginning of problems for the plant. Since after the civil war the plant has experienced declining production record until 1988 when its output got down to zero megawatts (MW); as at today the power plant is still down. [Iwuagwu, 2004]

###### **4.1.1.1 Carbon dioxide Emission**

The Oji power station uses bi-drum stoker fired boiler units with economizer and super heaters manufactured by Babcock and Wilcox Ltd of London. The boiler's steam evaporation rate is 96000lb/hr with a steam pressure and temperature of

470psi and 760°F respectively as seen on the name plate. The boiler is feed with ½- 1 inch (12.7 - 25.4mm) size coal lumps supplied from Enugu (Okpara mines).

As at the date (Apr 8, 2008) the plant was visited, the boilers are not fitted with any CO<sub>2</sub> emission reduction system; this is typical of the technological development and environmental awareness existing when the plant was built. The plant has no electrostatic precipitators; this is also typical of the stoker firing technology. The dust burden of the flue gas stream from the boilers is of a much lower order than that of a pulverized coal-fired boiler. [Barrett et al, 1971]

From literature (section 2.2.2.1), it is established that the CO<sub>2</sub> emission from a coal fired plant is about 15% by volume of the flue gas stream. It varies slightly with the grade of coal being burned in the boiler.

With a live CO<sub>2</sub> sampling conducted at Sasol synfuels coal-fired steam generating plant boilers (Unit 243 boiler #4), Secunda South Africa, the following result was obtained.

Table 4.1 Results of emission monitoring from a live plant

Instrument: Testo 300XL Gas Analyzer [Captured on March 28, 2008]						
Sample No	1	2	3	4	5	Avg.
°C	499	489	462	478	493	484.2
Vol.% O <sub>2</sub>	3.8	3.6	3.5	3.7	3.8	3.68
Ppm CO	3	3	4	3	4	3.4
Vol. % CO <sub>2</sub>	13.2	13.4	13.8	14	13.6	13.6
Ppm NO	2	1	1	3	2	1.8

The result of the CO<sub>2</sub> sampling conducted as shown in the table 4.1 above validates the information obtained from literature.

#### **4.1.1.2 Oji Plant Specific Data**

##### **Preamble**

In evaluating the state of the Oji river power station, a trip was made to the site and interviews conducted to gather plant specific data. Five technical staffs were interviewed; principal among them is the Oji power station manager Engr. L C Iwuagwu who also led the rehabilitation task team that did the last rehabilitation, commissioning and reliability testing exercise on the plant in 2004. Fortunately, a copy of the final report of the task team delivered to the Executive Director (Generation) of the PHCN corporate headquarters was collected.

##### **Summary of field findings**

The impact of the civil war on the Oji power plant is such that most of the useful plant documentations were lost. As a result of this, the post-civil war staff relied greatly on the experience of their pre-civil war counterparts to run the plant. With the effect of plant breakdowns over the time, dropping off on most of the units, and the eventual zero output of the plant today; there are minimal authoritative documents as per plant's operation to refer to. Consequent upon this, most of the plant's specific designed parameters sought for could not be obtained.

However, the interviews done provided insights on some of the parameters, also the name plates available in the plant aided the data gathering process. The following are the relevant obtained data:

***Boilers:***

Type = Stoker fired with economizer and superheaters

Capacity = 96,000 lb/hr, Design Pressure = 470 psi,

Steam temperature = 760 °F, Feed temp = 250 °F

***Turbines:***

Power = 10 MW

Speed = 3,000 RPM

***Generating Sets:***

Type = synchronous generators

Voltage = 11 kV

Power = 5 MW (Units 1 & 2),

10 MW (Units 3 & 4)

***Coal***

Sub-bituminous grade from Okpara mines

Moisture = 7.5%, Ash = 8.4%, Fixed carbon = 45.38%

Sulphur = 0.54%, Nitrogen = 1.44%, Hydrogen = 4.11%

Volatile material = 38.3%

Calorific value = 6628 kCal/kg

Cost = ₦7/kg

[Nigerian Coal Corporation, 2008]

But other parameters like plant capacity factor, flue gas rate, designed plant life, plant heat rate, plant installation cost, and boiler efficiency could not be sourced directly from the power station. Therefore, these parameters would be estimated accordingly, following knowledge gathered from literature and interview results.

#### **4.1.1.3 CO<sub>2</sub> Capture and Sequestration Cost**

The need to curb global warming requires an additional cost factor that will be used in installing GHG emission capture and sequestration systems on existing plants (emission sources). This aspect of the study relied mostly on cost estimates gathered from experts and vendors of commercially available CO<sub>2</sub> capture and sequestration systems. Notably, the IECM-cs software which has the capability of modeling the costs of a building base plant and its emission retrofits was also sourced and used for this purpose.

“The total cost of a standard design Fluor Daniel Econamine FG plant of 1000 te/d capacity is US \$29.50/tonne. This cost covers the total capital cost of the 1000 te/d CO<sub>2</sub> Econamine FG plant, including operating cost, capital cost recovery and SO<sub>2</sub> scrubbing cost, for a low sulphur coal-fired flue gas stream”.

[Chapel, Mariz, Ernest, 1999]

### **4.1.2 IECM-cs Overview**

The IECM-cs is the carbon sequestration version of the Integrated Environmental Control Model (IECM) desktop computer model used for systematic evaluation of different technology options of individual power plant. It can be applied to pulverized coal (PC), natural gas combined cycle (NGCC) and integrated gasification combined cycle (IGCC) power plants. The model takes into account the avoided carbon emissions, the impacts of multi-pollutant emissions, plant-level resource requirements, costs (capital, operating and maintenance), and net plant efficiency. It can be configured in these variants:

- PC plant with post-combustion capture
- PC plant with oxyfuel combustion
- NGCC plant with post-combustion capture
- IGCC plant with pre-combustion capture

The IECM model analyses plants of capacities 100 to 2500 MW. It contains updated database for generating the cost of the process and plant equipment based on different cost year basis selected in the model interface. The cost years covered in version IECM-cs 5.2.2 © 2008 is from 1977 to 2007, a span of 30 cost year basis. It can be used to easily model changes to a given plant, as such the IECM-cs model can enhances sensitivity analysis. [Rubin, 2007]

The following parameters are some of the standard inputs required from the user:

- Fuel properties (heating value, composition, delivered cost)

- Plant design (conversion process, emission controls, solid waste management, chemical Inputs)
- Cost factors (capital recovery factor, financial factors, plant capacity factors)

Based on the above inputs, the IECM model will generate the plant model which shows the plant process diagram or layout, plant & process performance, environmental emissions and plant & process costs. It presents the plant cost components in the levelized annual format. The levelized cost of electricity (LCOE) obtained takes into account the economic or book life of the modeled plant.

### **4.1.3 Cost of Electricity Generated**

Estimating the cost of electricity generated from a power station is usually a rigorous process that involves many inputs and considerations. For large scale projects such as building of power stations, the initial capital involvement is high. This may require pooling of resources from investors or securing finances from a financial institution usually at a given cost defined by the interest or borrowing rate. Also securing the investment with an insurance policy is common place and issues as corporate taxes are usually borne. The cost of fuel, Operation and maintenance costs of the plants are considered as well.

In line with the cost estimation, the rate of inflation, discount rates, plant life, capacity factor, time of construction, and depreciation of the plant are all factored

in before the cost of generating a unit of electricity can be calculated. It is only when this cost is determined that the investors can determine reliably the selling price (tariff) for the units of electricity generated. Mathematical models exist for estimating the cost of electricity generated.

One of the simple ways of estimating the cost of electricity generated is to spread the costs involved over the lifetime of the power plant, in other words, annualizing (levelized) the costs. The cost of electricity (COE) generated is therefore “the ratio of total annualized plant cost to the net electricity generated” by the plant.

$$\text{COE} = \frac{\text{Total Annualized plant cost}}{\text{Net electricity generated}}$$

This levelized annual cost method involves converting each component of the total owning cost of the plant into an annual levelized cost over the plant life. This approach brings in the annualizing factor otherwise called capital recovery factor. The capital recovery factor (CRF) converts a known present value into a stream of equal annual payments over a specified time, at a specified discount rate (interest). CRF is defined by the mathematical model below:

$$\text{CRF} = \frac{i(1+i)^n}{[(1+i)^n - 1]} \quad \text{where } i = \text{interest rate}; n = \text{no of annuities}$$

$$\text{Annuity (A)} = \text{Present Value} \times \text{CRF}$$

According to International Energy Agency (IEA), the levelized cost of electricity generated is given by the formula below [IEA, 2005]:

$$\text{COE} = \frac{\sum [(I_t + M_t + F_t) (1+i)^{-t}]}{\sum [E_t (1+i)^{-t}]}$$

Where:  $I_t$  = Investment expenditures in the year t

$M_t$  = Operations and maintenance expenditures in the year t

$F_t$  = Fuel expenditures in the year t

$E_t$  = Electricity generation in the year t

$i$  = Interest or discount rate

The cost of electricity generated from a coal fired power station can be calculated by applying the COE formula accordingly.

#### 4.1.4 Capacity Scaling

In the chemical/process industry, the estimation of the cost of a new plant is directly associated with the cost of an existing or reference plant performing the same functions and of same technology. This cost estimation is achieved through a mathematical model that also gives a good insight on economy of scale. The non-linear cost relationship used in estimating the cost of a new process plant from the known cost of an existing plant of a different size (capacity) is known as the **0.6 power law** or the **6-10th rule** [Rao, 2002]

Let  $C_a$  be the cost of an existing facility with capacity  $Q_a$ , and  $C_b$  be the estimated cost of the new facility which has a capacity  $Q_b$ . Then

$$C_b = C_a [Q_b/Q_a]^{0.6}$$

This rule can be used to estimate the total cost of a completely new facility with reference to a base case.

## **4.2 Results Analysis**

### **CO<sub>2</sub> Mitigation Economics**

Drawing on field data gathered, secondary data available from literature and other applicable data from government ministries and agencies, an analysis of the Oji coal power station potentials will be done. This will be done in two scenarios. The first scenario will discuss the case study, Oji river power station as it were (researched), while a second scenario will highlight a conceptual Oji river power station. In both scenarios, the economics of the doing CO<sub>2</sub> emission capture was shown through the cost of electricity generated.

#### **4.2.1 Scenario 1**

##### **4.2.1.1 Oji Base Case Analysis (30MW Plant)**

The figure 4.1 below shows the simplified gas-side process flow diagram of the existing Oji river power station. It shows the path of the flue gas from the boiler into the atmosphere through the stack. In this scenario, there is no emission control for carbon dioxide (CO<sub>2</sub>). The CO<sub>2</sub> emission rate into the atmosphere is 100%; this is otherwise called the “business as usual” operating scenario of the plant. This scenario typifies how the Oji power plant operated as per CO<sub>2</sub> emission.

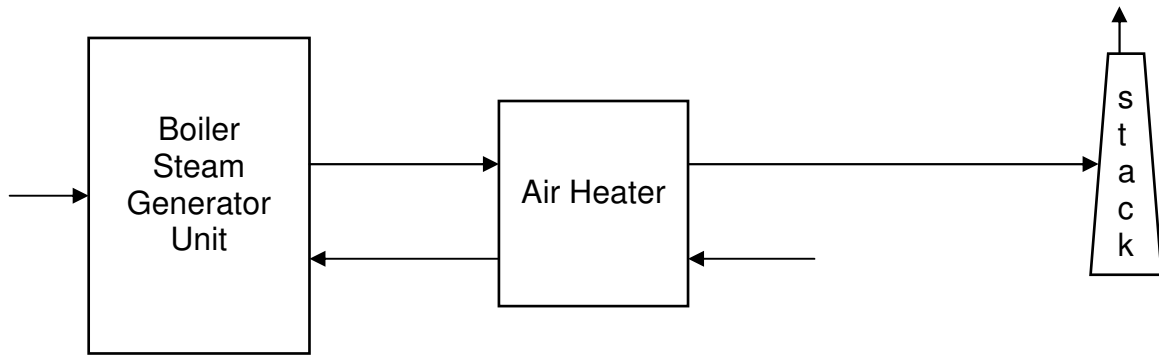

Figure 4.1 Simplified Gas side Process flow diagram of Oji Power station.

### **Constraints**

To estimate the cost of electricity generated from this plant, certain limitations persists, the IECM computer model is designed for pulverized coal plants, as against stoker firing technology used on site (Oji). In this scenario, the IECM modeling can not be applied based on this technology difference and capacity of the case study. The installation cost of the plant as-built could not be sourced as reported earlier. Also, the plant designed parameters such as plant life, capacity factor, heat rate and boiler efficiency are not available. The analysis following will be based on certain assumptions and inferences drawn from similar plants.

However, from literature the overnight construction cost of coal-fired power station are estimated at (1,000 – 1,500) US \$/kWe. The standard expected plant lifetime of a coal power station is 40years. [IEA, 2005]

### ***Assumptions:***

Considering the time (1956) when the plant was commissioned and prevalent situations then, these assumptions were made: an overnight construction cost of 1000 US\$/kW was adopted. Operation and maintenance is taking to be 4% of the total capital requirement (TCR) or investment cost of the plant. A 5% discount rate, capacity factor of 75%, 40years plant life was adopted. A coal consumption rate of 12 tonnes/hr was estimated from the report of the 2004 Oji river power station rehabilitation task team. Exchange rate of 1 US \$ = ₦120. The capital recovery for the plant will be based on 100% of the investment cost of the plant since the amount (percentage) already amortized was not obtained from field.

Based on the above premises, the cost of electricity (COE) for the 'business as usual' scenario will be:

$$\text{COE} = \frac{\sum [(I_t + M_t + F_t) (1+i)^{-t}]}{\sum [E_t (1+i)^{-t}]}$$

*Choosing the base (first) operation year of the plant as the basis for applying the*

COE formula, in that case;  $t=1$  and  $i = 0.05$

$$\text{But CRF} = \frac{[i(1+i)^n]}{[(1+i)^n - 1]} \text{ and } n = 40$$

$$\text{CRF} = 0.058$$

From overnight cost of 1000 \$/kW, the investment cost (TCR) of the plant will be:

$$\text{TCR} = 1000 \text{ \$/W} \times 30,000 \text{ kW} = \$ 30,000,000 = \text{M\$ } 30$$

Annualizing the Present value of the TCR

$$A = \text{CRF} \times \text{TCR} = \$ 1,740,000 = \text{M\$ } 1.74$$

NB: M\$ 1.74 =  $I_t$  for the first year (base) of operation

O&M cost:

$$4\% \text{ of TCR} = \$ 1,200,000 = \text{M\$ } 1.2$$

Plant yearly operational hours (PYH):

But plant capacity factor = 0.75

$$\text{PYH} = 0.75 \times 24 \times 365 = 6,570 \text{ hrs per annum}$$

Fuel cost, FC: (the total cost of fuel consumed over a specified period)

$$\text{But fuel (coal feed) cost} = \text{N7/kg} = \text{N7000/tonne} = \$ 58.3/\text{tonne}$$

$$\text{FC} = 6570 \text{ hrs} \times 12 \text{ tonnes/hr} \times \$ 58.3/\text{tonne} = \$ 4,596,372 = \text{M\$ } 4.6$$

Electricity generated (kWh):

$$30,000 \times 6570 = 197,100,000 \text{ kWh} = 197.1 \text{ GWh}$$

Therefore, the COE derived from the base year will be

$$\begin{aligned} \text{COE} &= [(\text{M\$ } 1.74 + \text{M\$ } 1.2 + \text{M\$ } 4.6)(1.05)^{-1}] / [197.1 \text{ GWh } (1.05)^{-1}] \\ &= [(\text{M\$ } 7.54) (1.05)^{-1}] / [197.1 \text{ GWh } (1.05)^{-1}] \\ &= \text{M\$ } 0.038 / \text{GWh} = \$ 0.038 / \text{kWh} \text{ (3.8 US cents/kWh)} \end{aligned}$$

#### 4.2.1.2 Base Case Retrofit Analysis

Considering the environmental setback of CO<sub>2</sub> emission on the base case and the need to capture and safely sequester the CO<sub>2</sub> out of the system. The base case plant has to be retrofitted with a proven commercially available CO<sub>2</sub> sequestration system. Integrating the Fluor Daniel Econamine FG plant (MEA-based system) on the base case, the modified gas-side process flow diagram of the power plant is as shown in figure 4.2.

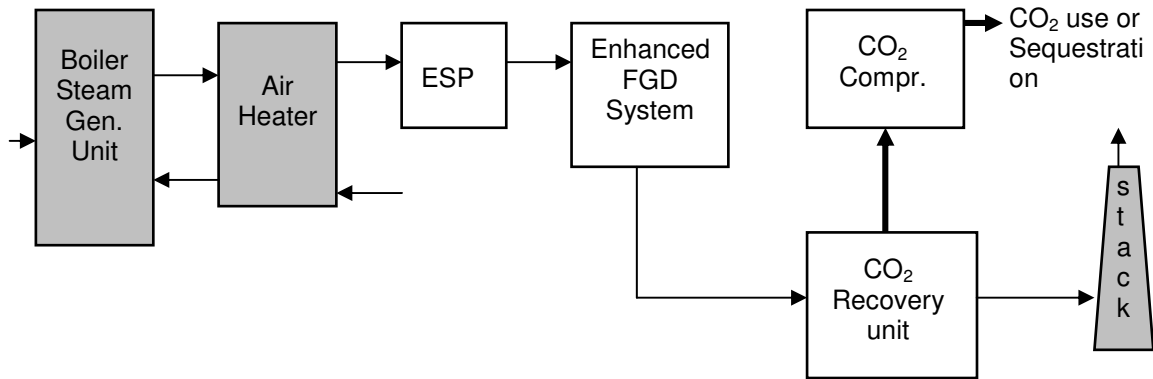

Figure 4.2 Modified Gas side Process flow diagram of Base case plant.

The integration of the CO<sub>2</sub> emission control plant into the base case causes an appreciable drop in the overall thermal efficiency and net electricity generated from the original power plant. The power consumed by the electrostatic precipitator (ESP), flue gas desulphurization system, MEA-based CO<sub>2</sub> recovery unit and the CO<sub>2</sub> compression accounts for the low net power output of the retrofitted plant. Best practice encourages generating the additional power requirement of the retrofit process equipment to maintain the base case net power output as designed originally. This make-up power is usually generated with an NGCC plant, which adds the make-up capacity at a competitive low cost with much lower emissions. [Simbeck, 2001]

### ***Assumptions***

To estimate the new cost of electricity based on the retrofitted plant, the new net output of the power station is assumed to be 25.5 MW by derating the base case by a factor of 15%. Also, taking the flue gas rate of the plant to be 86tonnes/hr

and the CO<sub>2</sub> emission rate to be 15% of the flue gas volume with capacity factor remaining as 75%, the new COE will be calculated.

***Cost Analysis of Scenario 1 Retrofitted Plant:***

From field results section; a standard Econamine FG plant applied to a low sulphur coal fired plant with a capacity of 1000 te/d of CO<sub>2</sub> costs \$ 29.50/tonne.

But the assumed Oji plant flue gas rate is 86 tonnes/hr, of which by volume CO<sub>2</sub> accounts for 12.9 tonnes/hr (15% of 86). On a daily basis, the total CO<sub>2</sub> emitted is 12.9 x 24 = 309.6 tonnes/d

Therefore applying the 6-10<sup>th</sup> rule of cost estimation to evaluate the cost of Oji Econamine FG plant:

$$C_b = C_a [Q_b/Q_a]^{0.6}$$

$$C_a = \$ 29.50/\text{tonne}, \quad Q_b = 309.6 \text{ tonnes/d}, \quad Q_a = 1000 \text{ tonnes/d}$$

$$C_a = \$ 14.60/\text{tonne}$$

$$\text{COE} = \frac{\text{Total Annualized plant cost}}{\text{Net electricity generated}}$$

$$\text{New COE} = [\text{Annualized old plant cost} + \text{Annualized Retrofit cost}] / [\text{Annualized Derated Net Electricity Generated}]$$

*Annualized Retrofit cost, in the base year:*

$$\text{With operational days/year} = 365 \times 0.75 = 274 \text{ days}$$

$$\begin{aligned} \text{Annualized retrofit cost} &= 274 \text{ days} \times \$ 14.60/\text{tonne} \times 309.6 \text{ tonne/day} \\ &= \$ 1,238,524 = M\$ 1.24 \end{aligned}$$

New Annualized Electrical Energy generated in the base year (kWh):

25.5 MW x operational yearly hours

$$= 25500 \text{ kW} \times 6570 \text{ hrs} = 167,535,000 \text{ kWh} = 167.5 \text{ GWh}$$

But the Annualized Old plant cost = M\$ 7.54 (recall from base case)

Therefore, New COE:

$$\begin{aligned} \text{New COE} &= [\text{M\$ } 7.54 + \text{M\$ } 1.24] / [167.5 \text{ GWh}] \\ &= \text{M\$ } 0.052/\text{GWh} = \$ 0.052/\text{kWh} \text{ (5.2 US cent/kWh)} \end{aligned}$$

## Summary

In this scenario 1, the cost of electricity generated without CO<sub>2</sub> emission capture is \$ 0.038/kWh while the cost of generation with CO<sub>2</sub> retrofit is \$ 0.052/kWh. The difference between the old and new COE shows an incremental cost of \$ 0.014 on each unit of electricity generated due to CO<sub>2</sub> emission control. But the result obtained is sensitive to assumptions made; therefore increasing the discount rate used in this scenario will also increase the indices above.

### 4.2.2 Scenario 2

#### Conceptual Oji Power station (500MW Plant)

This scenario considers the operation of a larger capacity coal-fired power plant in the Oji river power station environment. This conceptual plant uses modern pulverized coal low-NO<sub>x</sub> boilers with supercritical steam cycles, flue gas desulphurization system and electrostatic precipitator. This plant is built to conform to the current Nigerian environmental protection regulation: FEPA S.I.8/S.I.9 standard of 1991 [FEPA, 1991]. This current standard only regulates

emissions of SO<sub>2</sub> and NO<sub>x</sub> from power stations; as such CO<sub>2</sub> is not included. The impact of doing CO<sub>2</sub> emission control on this plant will be modeled using the IECM-cs computer software. The cost of electricity generated in this plant's non-CO<sub>2</sub> capture and CO<sub>2</sub> capture (retrofit) cases would be fully analyzed. **NB:** this scenario will be used extensively for further discussion.

#### 4.2.2.1 Conceptual Base Plant Analysis

The figure 4.3 below shows the new conceptual power plant process diagram, it contains the PC boiler, air heater, electrostatic precipitator, flue gas desulphurization system and smoke stack.

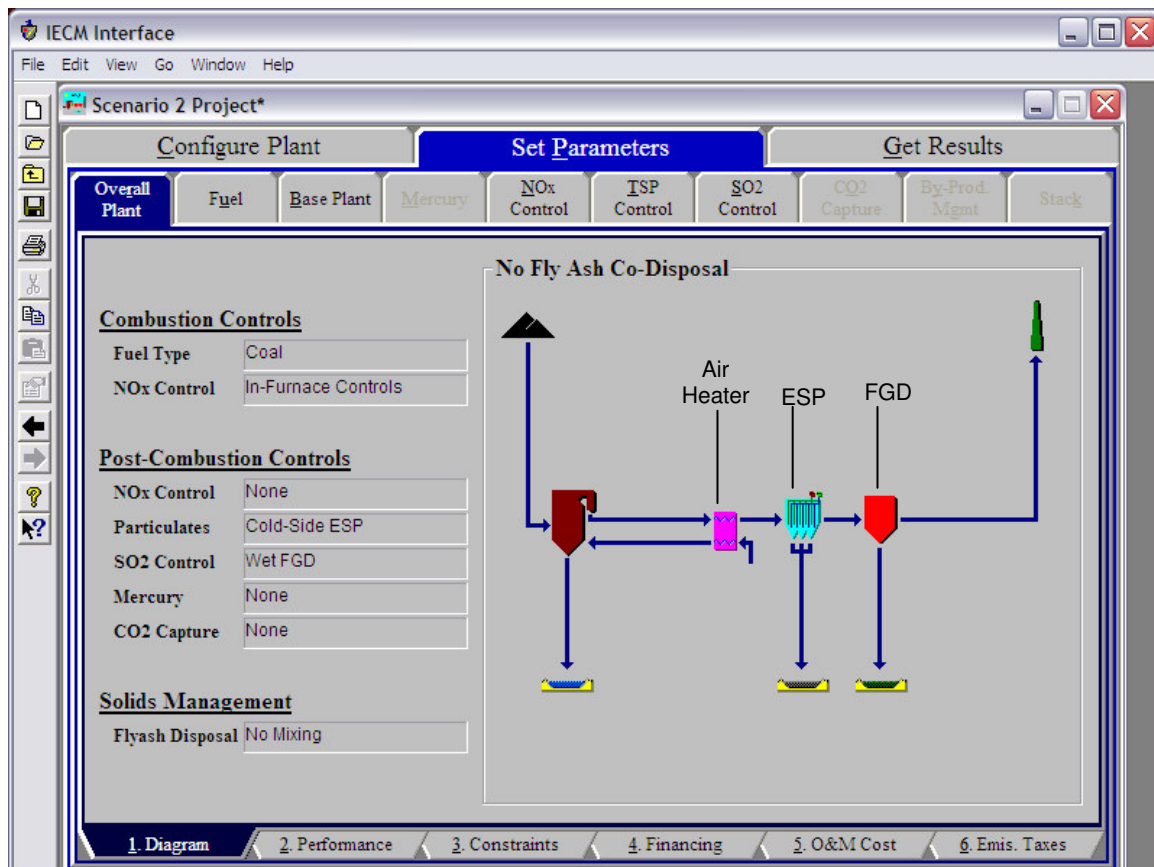

Figure 4.3 Scenario 2 Base plant process flow diagram

The following are inputs entered into the IECM-cs 5.2.2 © 2008 computer model interface. These inputs are chosen to depict as much as possible the realities of the Nigerian environment.

### ***Fuel Properties (Coal)***

Sub-bituminous coal grade: Moisture = 7.5%, Ash = 8.4%, Carbon = 45.38%

Sulphur = 0.54%, Nitrogen = 1.44%, Hydrogen = 4.11%, Oxygen = 5.11%

Calorific value = 11,930.41 Btu/lb (6628 kCal/kg), Cost = \$ 58.3/tonne (₦7/kg)

### ***Plant design***

Emission control: FEPA S.I.8/S.I.9 ( $\text{NO}_x = 500 \mu\text{g}/\text{m}^3$ ,  $\text{SO}_2 = 830 \mu\text{g}/\text{m}^3$ )

$\text{NO}_x$  control = In-furnace (LNB & SNCR) with Urea as reagent

$\text{SO}_2$  control = Wet FGD with limestone as reagent

### ***Cost factors***

Capital cost:

General facilities capital = 10% PFC (process facilities cost)

Engineering & home office fees = 6.5%PFC

Project contingency cost = 11%PFC, TCR recovery factor = 100%

Inflation rate = 5%, Discount rate = 12%, Corporate tax rate = 30%

Cost year basis = 2006, Plant life = 40years, Capacity factor = 85%

O&M cost:

Operating labour rate = \$ 15/hr, No of operating jobs = 20

Administrative & support cost = 7% total labor

Capital recovery factor (CRF):

$$\text{CRF} = \frac{i(1+i)^n}{[(1+i)^n - 1]} \text{ where } i = 0.12 (12\%); n = 40 (40\text{years})$$

CRF = 0.1213

The figure below shows some of the basic cost factor inputs to the IECM model



Figure 4.4 IECM interface showing cost factor inputs for Base Plant.

The result of running the IECM computer model shows the following costs:

1. The total capital requirement (TCR) for building the conceptual 500 MW Oji river power station is M\$ 660.4 as interpreted from figure 4.5 below
2. The cost of generating electricity with this base power plant is \$71.51/MWh (0.07151 \$/kWh) as interpreted in figure 4.5.
3. The total levelized annual cost of the plant is M\$ 247.1/Year.

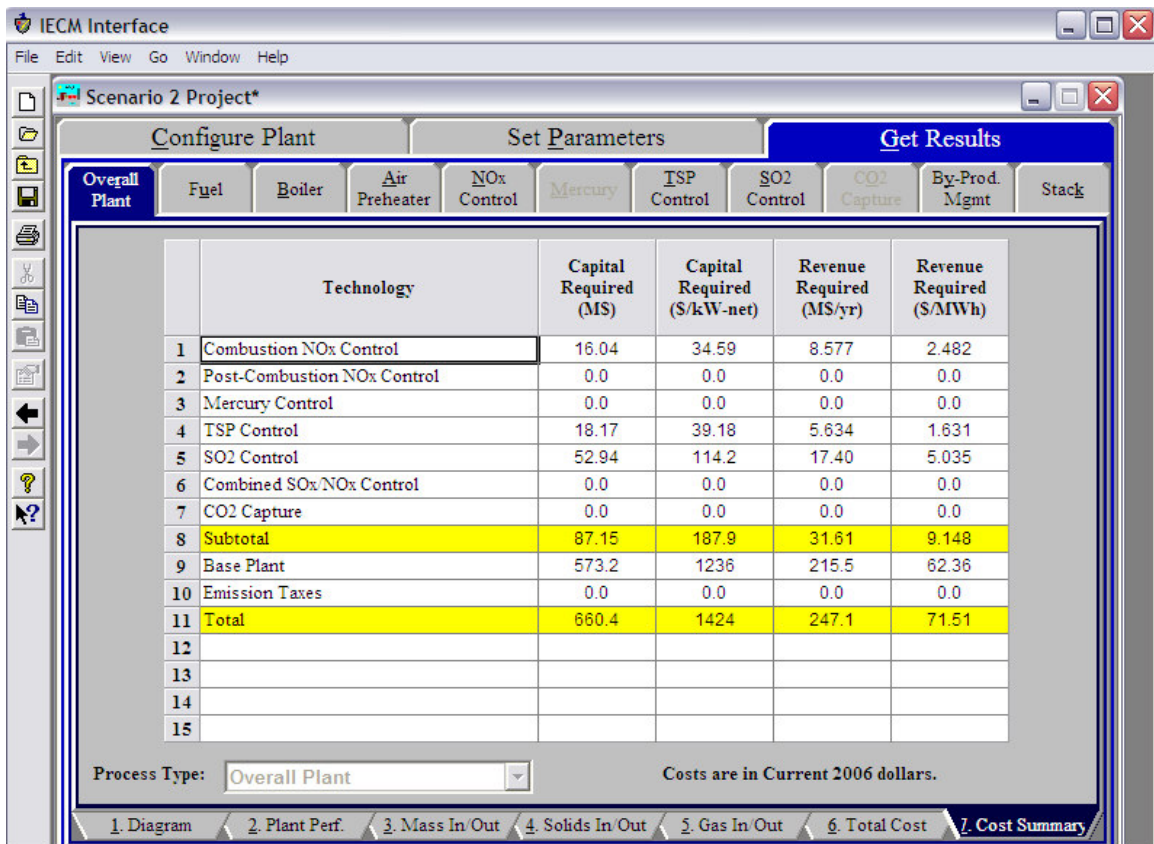
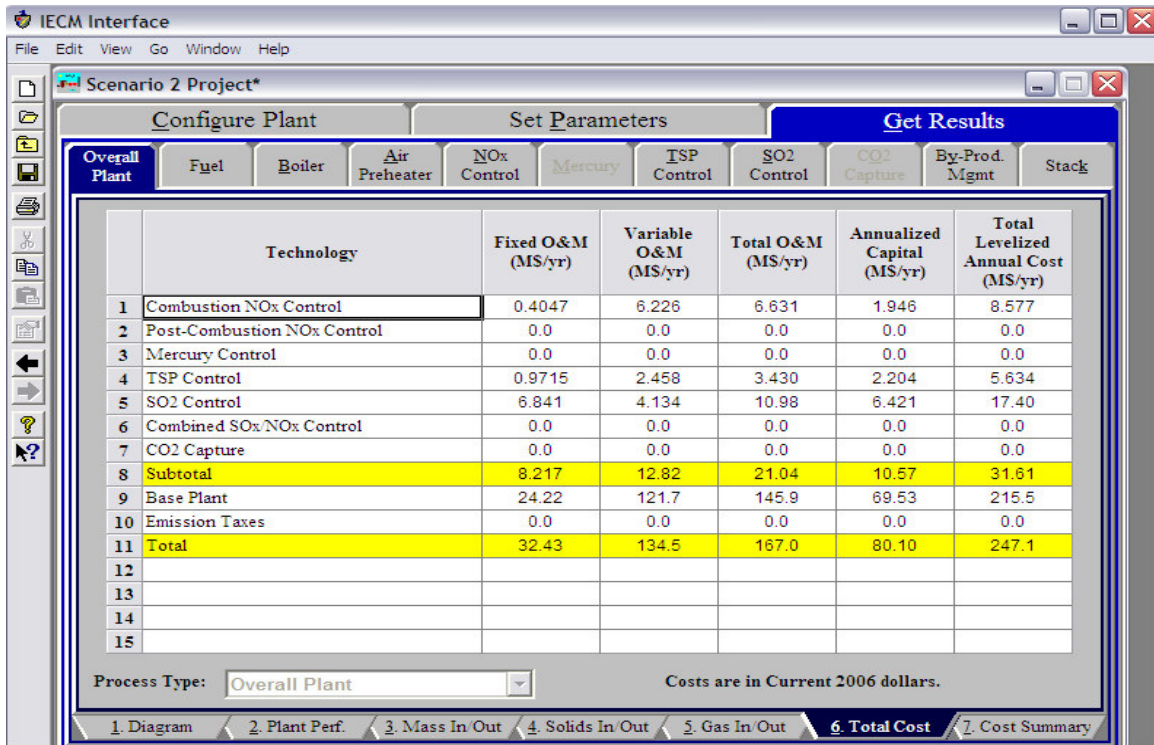

Figure 4.5 IECM interface Base Plant Cost outputs

The results of the conceptual base plant's performance are as follows:

The net generated power output is 463.7 MW with overall plant efficiency of 40.51% (HHV). The CO<sub>2</sub> emission rate from the base plant is 273.2 ton/hr as shown in the stack flue gas snap shot below.

Major Flue Gas Components	Aux. Boiler Out (lb-moles/hr)	Stack Out (lb-moles/hr)	Total Out (lb-moles/hr)	Aux. Boiler Out (tons/hr)	Stack Out (tons/hr)
1 Nitrogen (N2)	0.0	7.909e+04	7.909e+04	0.0	1108
2 Oxygen (O2)	0.0	5906	5906	0.0	94.50
3 Water Vapor (H2O)	0.0	2.069e+04	2.069e+04	0.0	186.4
4 Carbon Dioxide (CO2)	0.0	1.241e+04	1.241e+04	0.0	273.2
5 Carbon Monoxide (CO)	0.0	0.0	0.0	0.0	0.0
6 Hydrochloric Acid (HCl)	0.0	0.5541	0.5541	0.0	1.010e-02
7 Sulfur Dioxide (SO2)	0.0	16.49	16.49	0.0	0.5283
8 Sulfuric Acid (equivalent SO3)	0.0	8.065e-02	8.065e-02	0.0	3.228e-03
9 Nitric Oxide (NO)	0.0	19.55	19.55	0.0	0.2934
10 Nitrogen Dioxide (NO2)	0.0	1.029	1.029	0.0	2.367e-02
11 Ammonia (NH3)	0.0	1.670	1.670	0.0	1.422e-02
12 Argon (Ar)	0.0	943.8	943.8	0.0	18.85
13 Total	0.0	1.191e+05	1.191e+05	0.0	1681
14					
15					

Process Type: Stack

Figure 4.6 IECM interface Base Plant Flue gas output.

#### 4.2.2.2 Conceptual Base Plant's Retrofit Analysis

In this case, implementing CO<sub>2</sub> emission control on the conceptual Oji power plant with an Amine-based CO<sub>2</sub> capture system, the modified process flow diagram of the plant is shown as figure 4.7 below. The process flow diagram

highlights the removal of carbon dioxide from the flue gas before being discharged into the atmosphere through the stack.

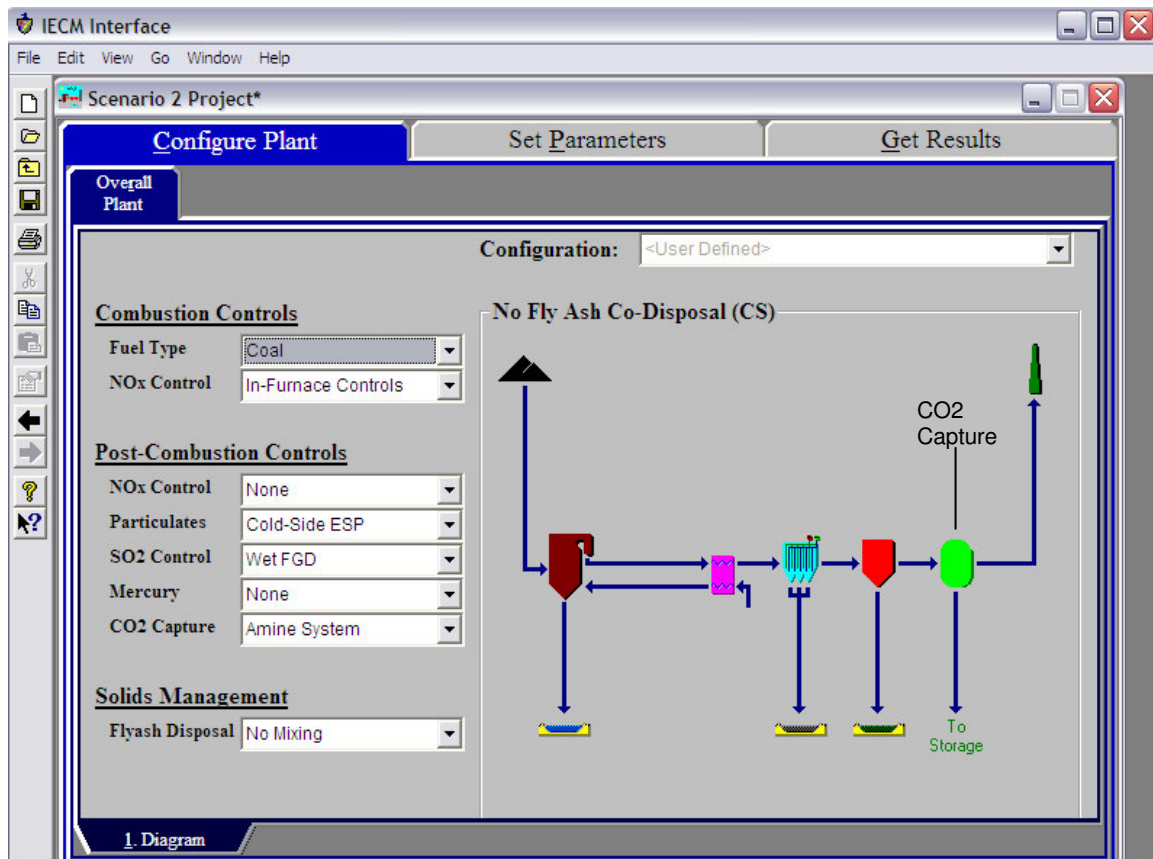

Figure 4.7 Modified process flow diagram of the scenario 2 base plant

### ***IECM Interface Inputs:***

The original (scenario 2 base plant's) inputs to the IECM model are retained as in the non- CO<sub>2</sub> emission capture case already discussed. However the total CO<sub>2</sub> removal efficiency of the MEA (Amine) based emission control system is set to 95% with other relevant CO<sub>2</sub> parameters left on their default settings. For this analysis the CO<sub>2</sub> captured is pumped to a geological reservoir for storage. There is no replacement power (make-up) scheme for the CO<sub>2</sub> emission control equipment used.

The following are the results of running the IECM computer model with the integration of the Amine-based CO<sub>2</sub> capture and sequestration system on the base plant (500MW) cost and performance:

1. The CO<sub>2</sub> emission rate of this retrofitted plant is reduced to 27.35ton/hr as interpreted from figure 4.8 below
2. The total capital requirement for achieving the plant CO<sub>2</sub> retrofit is M\$147.1 (M\$ 807.5 - M\$ 660.4) as interpreted from figure 4.9
3. The new cost of electricity generated is \$ 108.9/MWh (0.1089 \$/kWh)
4. The net power output obtained from the retrofitted plant is 388.9MW with overall plant efficiency of 33.98% (HHV)

Scenario 2 Project\*

Configure Plant      Set Parameters      Get Results

Overall Plant   Fuel   Boiler   Air Preheater   NOx Control   Mercury   TSP Control   SO2 Control   **CO2 Capture**   By-Prod. Mgmt   Stack

	Major Flue Gas Components	Flue Gas In (lb-moles/hr)	Flue Gas Out (lb-moles/hr)	Flue Gas In (tons/hr)	Flue Gas Out (tons/hr)
1	Nitrogen (N <sub>2</sub> )	7.909e+04	7.909e+04	1108	1108
2	Oxygen (O <sub>2</sub> )	5900	5900	94.39	94.39
3	Water Vapor (H <sub>2</sub> O)	2.009e+04	2.009e+04	186.4	186.4
4	Carbon Dioxide (CO <sub>2</sub> )	1.243e+04	1243	273.5	27.35
5	Carbon Monoxide (CO)	0.0	0.0	0.0	0.0
6	Hydrochloric Acid (HCl)	0.5541	2.771e-02	1.010e-02	5.051e-04
7	Sulfur Dioxide (SO <sub>2</sub> )	1.067	5.333e-03	3.417e-02	1.708e-04
8	Sulfuric Acid (equivalent SO <sub>3</sub> )	8.065e-02	4.032e-04	3.228e-03	1.614e-05
9	Nitric Oxide (NO)	19.55	19.55	0.2934	0.2934
10	Nitrogen Dioxide (NO <sub>2</sub> )	1.029	0.7718	2.367e-02	1.775e-02
11	Ammonia (NH <sub>3</sub> )	1.670	7.155	1.422e-02	6.093e-02
12	Argon (Ar)	943.8	943.8	18.85	18.85
13	Total	1.191e+05	1.079e+05	1681	1435
14					
15					

Process Type: **Amine System**

1. Diagram   2. Flue Gas   3. Bypass   4. Capital Cost   5. O&M Cost   6. Total Cost   7. Misc.

Figure 4.8 Scenario 2 Flue gas analysis for the Retrofitted plant

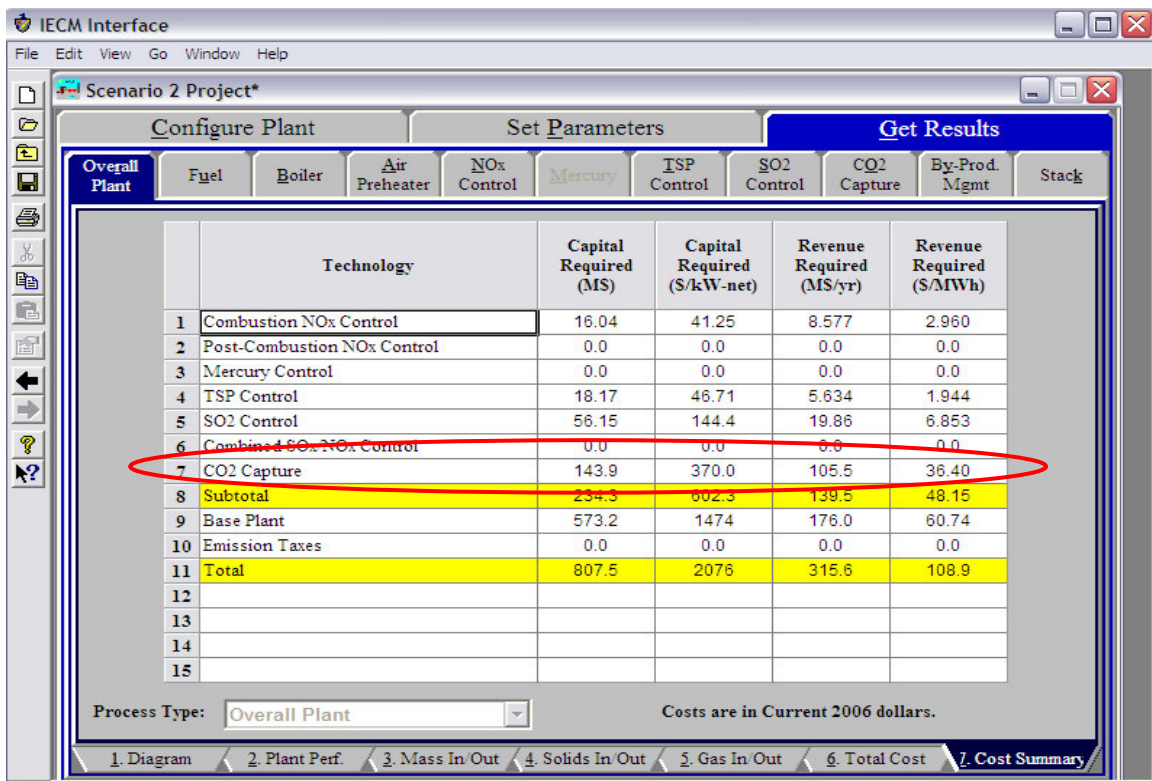
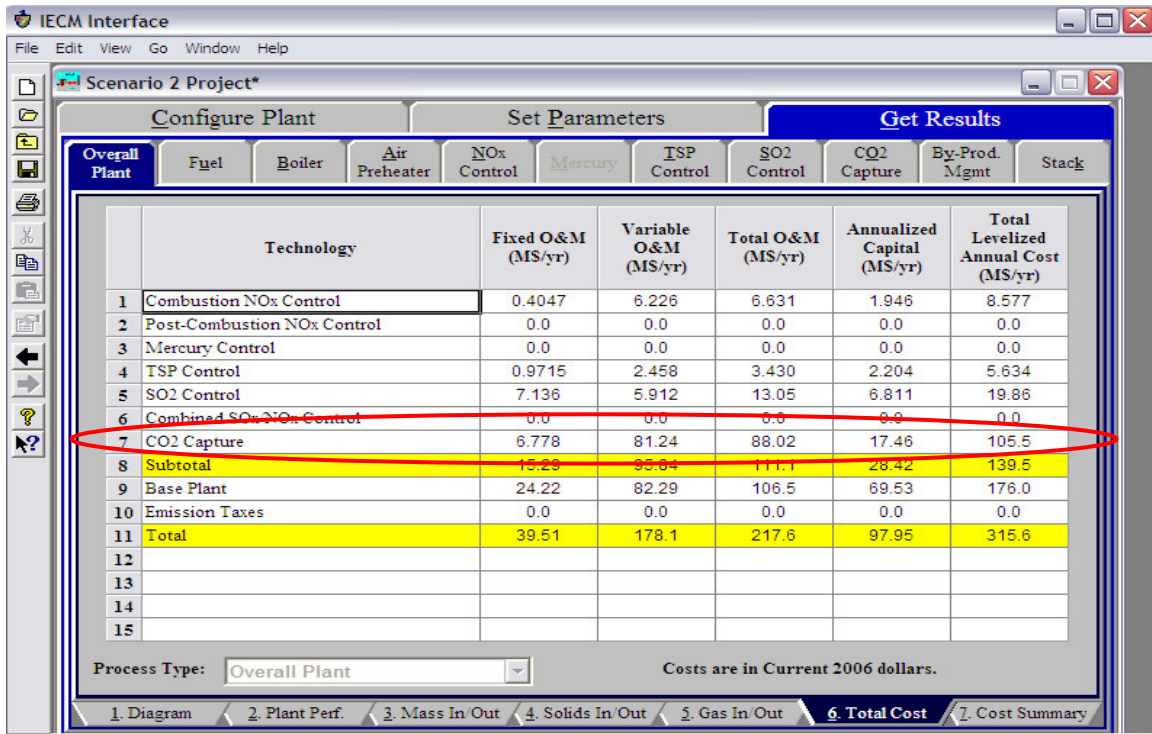

Figure 4.9 Effect of CO<sub>2</sub> retrofit cost on Scenario 2 Base Plant

## Comparison of the Base and Retrofitted Plants (Scenario 2)

Table 4.2 Comparison of the Base and Retrofitted plants (Scenario 2)

Parameter	Units	Base Plant	Retrofitted Plant	Percentage change
Net Power output	MW	463.7	388.9	16.13
Net Thermal Efficiency	%	40.51	33.98	16.12
CO <sub>2</sub> Emission Rate	tonnes/hr	273.2	27.35	90
Cost of Electricity	\$/kWh	0.0715	0.1089	52.3
CAPEX (TCR)	M\$	660.4	147.1	22.3

### 4.2.3 Cost of CO<sub>2</sub> Avoided

For environmental analysis the cost of an environmental control system is given in terms of its cost per tonne of the pollutant removed or avoided. The cost of CO<sub>2</sub> avoided is an economic indicator that shows the CO<sub>2</sub> emission reduction of a capture unit on the basis of per net kWh delivered by a power plant. The cost of CO<sub>2</sub> avoided is calculated from the given formula below:

$$\text{Cost of CO}_2 \text{ Avoided (\$/tonne)} = \frac{(\$/\text{kWh})_{\text{retrofit}} - (\$/\text{kWh})_{\text{base}}}{(\text{tonne CO}_2/\text{kWh})_{\text{base}} - (\text{tonne CO}_2/\text{kWh})_{\text{retrofit}}}$$

From the table 4.2, the energy delivered in one hour by each of the plants is 463,700 kWh and 388,900 kWh for the base and retrofit cases respectively. Therefore the CO<sub>2</sub> emission in tonne/kWh for the plants are  $5.892 \times 10^{-4}$  and  $7.033 \times 10^{-5}$  for the base and retrofit cases respectively. Applying the CO<sub>2</sub> emission in tonne/kWh into the above formula, the Cost of CO<sub>2</sub> avoided will be:

$$\text{Cost of CO}_2 \text{ Avoided (\$/tonne)} = [0.1089 - 0.0715] / [5.892 \times 10^{-4} - 7.033 \times 10^{-5}]$$

**Cost of CO<sub>2</sub> Avoided = 72.08 \\$/tonne**

The slope of the graph of COE (\\$/kWh) vs. CO<sub>2</sub> emission rate (tonne/kWh) also defines the cost of CO<sub>2</sub> avoided by an emission control system, as shown below.

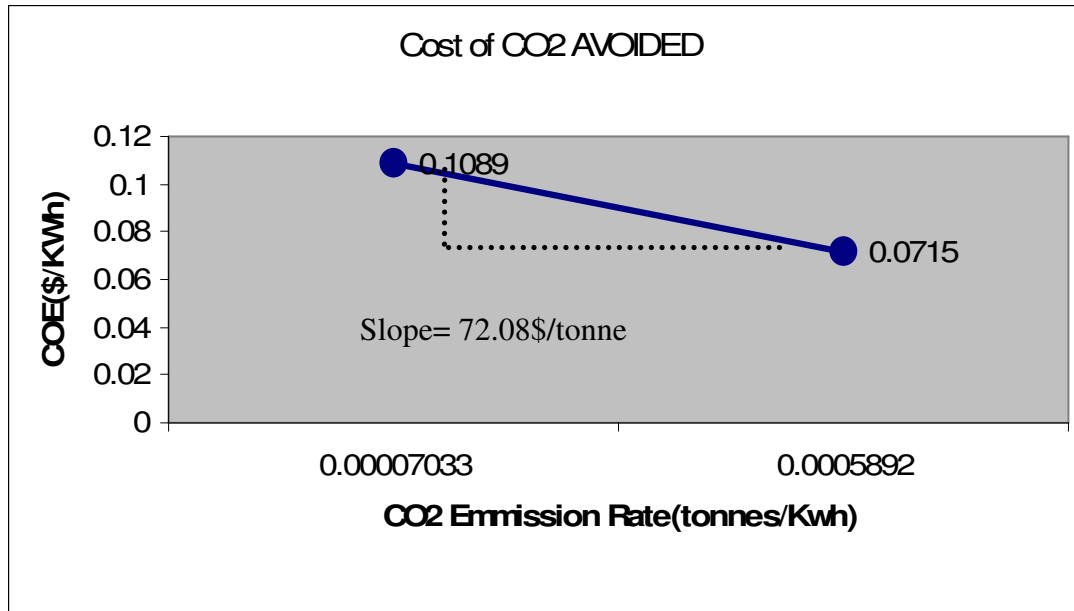

Figure 4.10 Graph of Cost of CO<sub>2</sub> avoided.

## 4.3 Discussion of Results

### 4.3.1 Future of Nigerian coal power stations

The following sections discuss the future of coal-based power generating stations in Nigeria with global warming constraints. The competitiveness of the coal resource for power generation will be discussed alongside other resources available for power generation in the Nigerian economy.

#### 4.3.1.1 GHG Emission Control in Nigeria

“Article 4 of the United Nations Framework Convention on Climate Change (UNFCCC) requires each party to periodically report the emissions of greenhouse gases (GHGs)” in their first national communication. This report is developed according to IPCC guidelines which documents the inventory of GHGs by sources and sinks. [ELAW, 2008]

Based on this initiative, the Nigerian government submitted its first national communication under the UNFCCC in 2003. The federal government shows a level of commitment to the pursuit of GHG emissions reduction through some of its programme as outlined in the communication report. For the energy sector the following are outlined as Nigerian mitigation approaches:

- *“Efficiency improvement options in the residential, industrial and commercial sectors*
- *Increased use of renewable resources, consisting of the introduction of small-scale hydro plants and solar-electric options*
- *Supply-side options, especially rehabilitation of some existing oil refineries and power plants, and the introduction of newer technologies*
- *Options for increased use of natural gas”*

As outlined, some of them will be achieved at a ‘net negative cost’; typical is the introduction of compact fluorescent lamps against the use of incandescent lamps, while others will attract additional cost. [MOE, 2003; ELAW, 2008]

The following charts show the sources of CO<sub>2</sub> emissions in Nigeria and the potential on global warming if uncontrolled in the next few years.

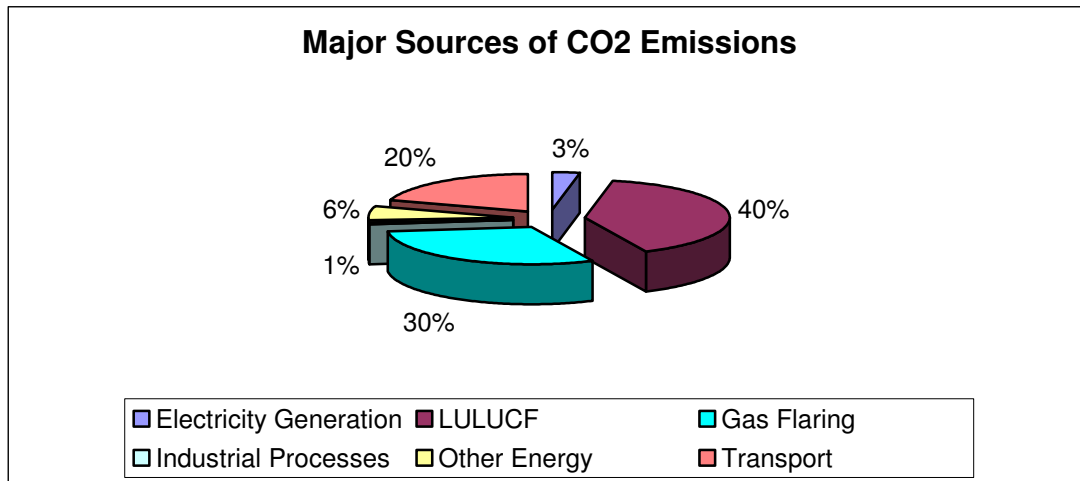

Figure 4.11 Major sources of CO<sub>2</sub> emission in Nigeria [Source: MOE, 2003]

NB: LULUCF = Land use, Land-use Change and Forestry [UNFCCC, 2007]

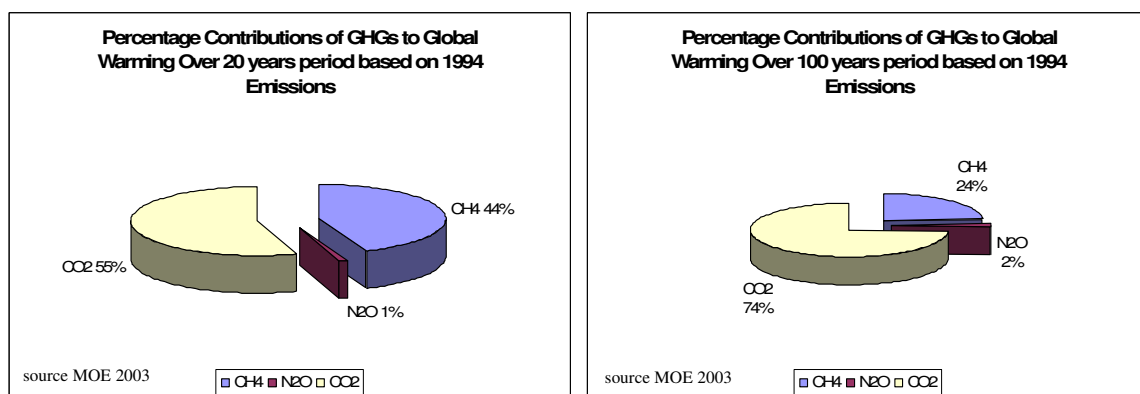

Figure 4.12 Projected effect of CO<sub>2</sub> on Global warming in Nigeria

From figure 4.11, the 3% contribution of electricity generation to CO<sub>2</sub> emission is attributable to gas-fired power generating stations as there is no operational coal based power station as at then. But from the projected (figure 4.12) effect of CO<sub>2</sub> on global warming, there is an increase in the contribution made by CO<sub>2</sub>. This is partly due to the need to increase power generation capacity of the Nigerian

economy. Presently, the per capita energy consumption of Nigeria is 7.9million BTU/person which is a far cry compared to what is obtainable in developed countries. [Miller BG, 2005]

## **Kyoto Protocol Compliance - CO<sub>2</sub> Emission in Nigeria Coal Power Stations**

The Kyoto protocol sets a binding target for all Annex 1 (industrialized nations) parties to reduce their GHG emissions by an average of 5 percent within the first compliance period of 2008 - 2012 against their 1990 levels. [United Nations, 1998] This emission reduction target is expected of all the non-Annex 1 parties alike as a way of commitment but not as a binding regulation, this is where Nigeria falls in, following its ratification of the protocol. According to Article 10 of the Kyoto protocol “Both Annex I and non-Annex I Parties must cooperate in the areas of:

- *The development, application and diffusion of climate-friendly technologies;*
- *Research on and systematic observation of the climate system;*
- *Education, training, and public awareness of climate change;*
- *The improvement of methodologies and data for greenhouse gas inventories.”*

From the field results (section 4.1.1.1) the only coal-fired power station in Nigeria is currently not generating power. However following its operations history, the

industry does not comply with CO<sub>2</sub> emission control. As such the provisions of Kyoto protocol is not met in the plant.

However with the need to boost Nigeria's power generation vis-à-vis building new power stations and rehabilitating old ones, the deployment of the coal option has to be considered alongside its CO<sub>2</sub> emission constraints. This is because of the fact that coal power stations are long lasting in service, CO<sub>2</sub> intensive and are prone to tightening GHG emission regulation.

With the expiration of the first compliance period of the Kyoto protocol, a possible re-negotiation can place more stringent demands on its non-Annex 1 parties. This will portend a more rigorous search for affordable means of attaining sustainable development merits.

### **Kyoto Mechanisms**

As a means of controlling for the quantity of GHGs emitted, each of the Annex 1 parties to the Kyoto protocol is given an emission limit called the assigned amount. This assigned amount unit serves like the party's reserves for emission, under no circumstance is a party supposed to exceed its assigned amount. This is the aspect of the Kyoto protocol that binds each Annex 1 party to a responsibility (commitment) under the implementation period [United Nations, 1998]

However, the Kyoto protocol is made flexible in some ways to accommodate coordinated interactions among the parties to foster emission management. The levels of emission allowed for each party can only be changed under the commitment period by the trading of Kyoto protocol unit with other parties through any of these Kyoto mechanisms:

- Emissions trading
- Clean development mechanism (CDM)
- Joint implementation (JI)

Under emissions trading, an Annex I Party is entitled to transfer/acquire Kyoto protocol units to/from another Annex I Party. This engagement is usually done by the party in order to stay within the limits of its assigned amount. However if a party acquire units from another party, the acquiring party will add the additional units to its assigned amount while the transferring party will subtract that units for its own assigned amount. By so doing, the entire emission trading scheme is regulated as not to exceed the reserves allowed under the protocol. [UNFCCC, 2007]

The clean development mechanism is a project-based approach of interaction among parties. However this mechanism is not limited to the Annex 1 parties alone, it is extended to the non-Annex 1 parties alike. “The main purpose of the clean development mechanism is to assist non-Annex I parties in achieving sustainable development”. It also contributes to the ultimate objective of the protocol by assisting the Annex I parties in generating emission credits through

the implemented CDM projects. The emission allowances from CDM projects are called “certified emission reductions (CERs)”. The CER represents an allowance to emit GHG of 1 metric tonne of CO<sub>2</sub> equivalent. [UNFCCC, 2007]

Joint implementation (JI) is similar to the CDM, but it differs from CDM in that it is restricted to Annex 1 parties only. The Joint implementation is a mechanism through which an “Annex I Party can invest in an emission reduction project in another Annex 1 party, and receive credit for the emission reductions or removals achieved through that project”. The unit associated with JI is usually called an “emission reduction unit (ERU)”. [UNFCCC, 2007]

#### **4.3.1.2 Power Generation Options**

The Nigerian electricity generation is currently based on hydro and gas-fired thermal power generation. Of the reported 3750MW of electricity generated in 2005, natural gas, hydro, oil and coal contributed 68.63, 31.01, 0.36, and 0 percents respectively. [Sambo et al, 2006; MSMD, 2006a]

However, according to the Energy Commission of Nigeria, (ECN) coal will be responsible for 6.93% of the estimated (31,758MW) future installed electricity generation capacity of the country by 2030. [Sambo et al, 2006] This implies about 2.2GigaWatts of electricity derivable from coal-fired power stations and approximately an additional 12 million metric tons of CO<sub>2</sub> emission in the

absence of emission controls. The table 4.3 below the shows ECN reference scenario for future installed electricity generation capacity mix by fuel types.

Table 4.3 Estimated future installed electricity generation capacity by fuel mix

Year	MW	Coal	Natural Gas	Oil	Hydro
		<b>Shares, %</b>			
2005	3750	0.00	68.63	0.36	31.01
2010	10556	0.00	76.41	4.36	19.23
2015	15308	5.23	67.40	4.31	23.06
2020	18858	7.54	70.36	3.50	18.72
2025	24208	8.26	70.92	4.38	16.44
2030	31758	6.93	75.31	5.32	12.53

[Source: ECN, 2006]

The table above shows an increasing potential for coal alongside natural gas. But natural gas-fired thermal power stations are more emission controlled (efficient) compared to its coal-fired counterpart of the same capacity. Though at the moment, the existing natural gas-fired power stations are not CO<sub>2</sub> retrofitted, they are relatively less carbon intensive.

### ***What then is the fate of coal?***

Drawing from the results obtained in the CO<sub>2</sub> mitigation analyses (section 4.2): scenario 1 shows a 36% increase in unit cost of electricity generated with CO<sub>2</sub> emission control while scenario 2 gave a 52% increase. The variation in these results are attributable to the cost factors used in the analyses, a discount rate of 5% was used for scenario 1, while 12% was applied to the scenario 2. Scenario 2 analyzed a more modern coal-fired power station which is multi-pollutant emission compliant. The number of pollutants controlled in any coal-fired power plant and the levels to which the pollutants are controlled are key cost factors.

## **Coal Vs Natural Gas**

In the Nigerian economy, gas-fired power stations seems to be favoured over other options, this is evident in the ECN projected future energy generation capacity for the country. Statistics (table 4.3) shows that gas contributes the highest percentage of power on the grid and will continue in that trend. The hydro-power potentials of Nigeria seem to be dwindling; as such the competitiveness of coal in the electricity generation mix will be compared with natural gas.

Natural gas is fast becoming a fuel of choice in Nigeria, following many efforts at monetizing the resource which was formerly being wasted through flaring. OGJ (Oil & Gas Journal) "estimates that Nigeria had an estimated 182 trillion cubic feet (Tcf) of proven natural gas reserves as of January 2007, which makes Nigeria the seventh largest natural gas reserve holder in the world and the largest in Africa" [EIA, 2007]

Natural gas is being managed by the Nigerian Gas Company, NGC a subsidiary of the NNPC. The price of Natural gas in Nigeria has been ₦21.05/Mcf (approximately \$ 0.20/Mcf). But there is a current 221.28 percent price hike which now places the price of natural gas at ₦67.63/Mcf (\$ 0.56/Mcf). This recent increase in price is causing some agitation in the economy [Ejiofor, 2008]

Applying the IECM-cs computer model to a 500 MW gas-fired (NGCC) power plant with a capacity factor of 85% using the prevailing cost of gas at \$ 0.56/Mcf; and other cost factor as employed in the scenario 2 CO<sub>2</sub> mitigation analysis, the following results were obtained.

***For the base NGCC plant without CO<sub>2</sub> recovery:***

Net power output = 506.2 MW

Net plant efficiency = 50.15%

CO<sub>2</sub> emission rate = 205.1 tonne/hr

Total capital requirement = M\$ 342

Levelized COE = \$ 19.53/MWh (\$ 0.02/kWh)

***For the base NGCC plant with Amine-based CO<sub>2</sub> recovery system:***

Net power output = 432.3 MW

Net plant efficiency = 42.80%

CO<sub>2</sub> emission rate = 20.51 tonne/hr

Total capital requirement = M\$ 478.2

Levelized COE = \$ 39.38/MWh (\$ 0.04/kWh)

Doing a side by side comparison of the coal and natural gas electricity generation options based on 500MW capacity generation in Nigeria, the following table is obtained. The table 4.4 below summarizes the base indicators for evaluation of the two generation options.

Table 4.4 Comparison of CO<sub>2</sub> sequestration of Coal and Gas stations

Parameter	Units	Coal without Retrofit	Coal with Retrofit	Gas without Retrofit	Gas with Retrofit
Net Power output	MW	463.7	388.9	506.2	432.3
Net Thermal Efficiency	%	40.51	33.98	50.1	42.8
CO <sub>2</sub> Emission Rate	tonnes/hr	273.2	27.35	205.1	20.51
Cost of Electricity	\$/KWh	0.0715	0.1089	0.0195	0.0394
Overall CAPEX (TCR)	Million \$	660.4	807.5	342	478.2

From the table above the chart of the impact of the CO<sub>2</sub> capture system is shown on the net power output from the plants. The coal based generation option shows a greater percentage (16.1%) loss of net output as compared with the gas station (14.5%). This net output reduction has a bearing also on the plant thermal efficiency.

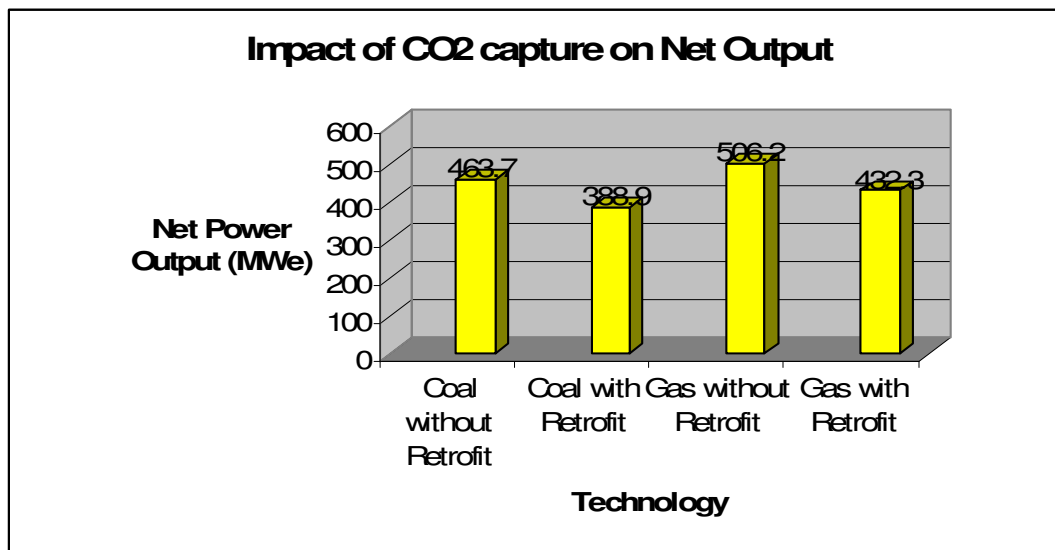

Figure 4.13 Impact of CO<sub>2</sub> Capture on Net Power Output

However, the two energy options showed similar characteristics with the amount of CO<sub>2</sub> emission reduction achieved. This is because the same emission control

system was implemented in the two cases. The percentage emission reduction achieved using the Amine-based CO<sub>2</sub> capture system shows consistency for both coal and gas power plant application (approximately 90%).

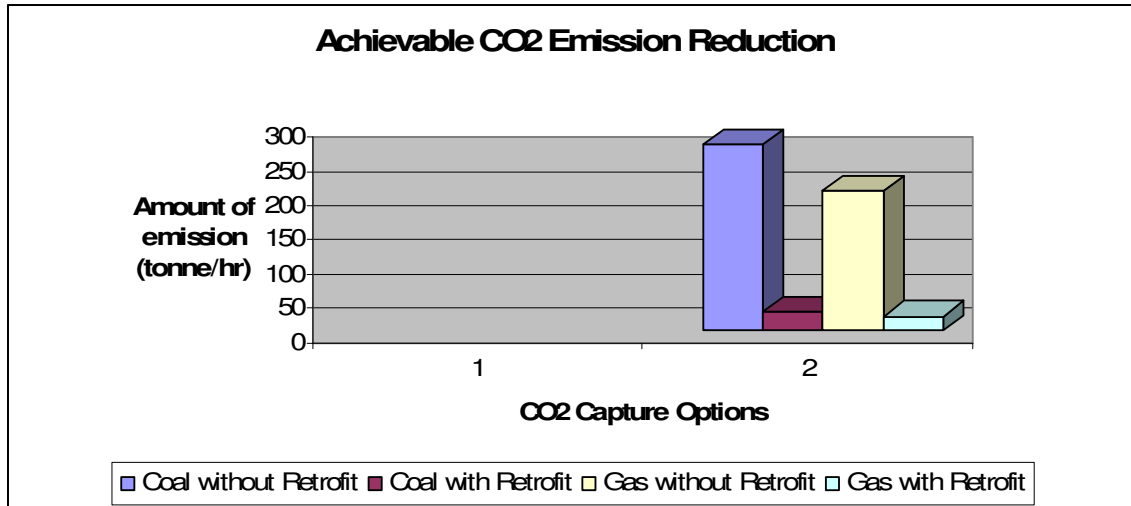

Figure 4.14 Achievable CO<sub>2</sub> Emission Reduction

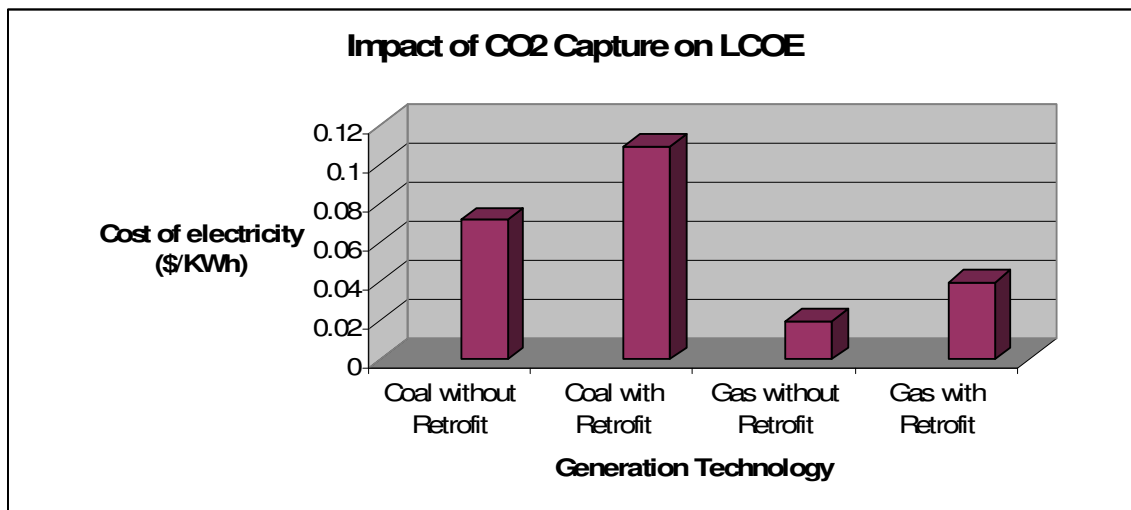

Figure 4.15 Impact of CO<sub>2</sub> Capture on levelized cost of electricity

From chart above figure 4.15, the levelized cost of electricity shows a marked difference between the two options. For both base cases and retrofit cases of

the two energy options natural gas proved to be the cheaper technology for generating power under the conditions of the analysis.

However, the levelized cost of electricity comparison further shows that the coal option requires a cost of \$ 72.1/tonne for CO<sub>2</sub> avoided (recall cost of CO<sub>2</sub> avoided in 4.2.3). For natural gas, the cost of CO<sub>2</sub> avoided is \$ 55.6/tonne. This cost is cheaper compared to coal; the reason is simply because of the carbon intensities of the energy options. Gas is less carbon intensive.

Based on this economic analysis for CO<sub>2</sub> mitigation, in the Nigeria economy natural gas is preferable. Except if there is a mechanism in place to reduce the cost of coal drastically, in the face of natural gas option and need to reduce emission of GHGs in Nigeria, economically speaking coal is not a cost-effective option for power generation. With the new electricity tariff of ₦11/kWh (\$0.0917/kWh), it is only the base case of scenario 2 that can be accommodated for coal at \$ 0.0715/kWh. The coal station retrofit of scenario 2 defies economic principles at \$ 0.1089/kWh.

In Nigeria, natural gas is quite cheap compared to what obtains in the international scene; as such the low price of \$ 0.56/Mcf is by far cheaper than global gas prices of about \$ 10/Mcf. Whereas, the price of coal as supplied by the Nigerian coal corporation is expensive relative to international coal market. Nigerian coal stands at \$ 58.3/tonnes (3.1 \$/GJ) as against global prices ranges

of (0.1 – 3.18 \$/GJ). Typically, South African coal is about the cheapest in the coal market, with its price remaining at 0.1 \$/GJ for the next 40years projected period. [IEA, 2005]

### **The Coal Option**

Coal-fired power plants due to their high investment costs require consistent operation at their rated capacity to have a competitive cost of electricity generated. As a result, “coal-fired plants are better used as base load components of electricity generation in an extensive grid system. The base load is defined as the average minimum demand in a 24-hour period”. [MSMD, 2006a]

It is uneconomical to use coal power stations for supporting ‘peak-time’ demand or intermittent power generation, as such, “the Nigerian grid system requires a combination of coal-fired plants to carry the base load and gas-fired plants that can be started up and shut down as the peaking loads increase and decrease during a 24-hour cycle”. This scenario can be achievable under the projected future growth in the Nigerian electricity supply. [MSMD, 2006a]

More so, coal based power generation is not a write off in the Nigerian environment due to the government’s role on electricity tariff subsidy and equalization through the regulatory arm, NERC (Nigerian Electricity Regulatory Commission). The selling price of electricity to the public (domestic, commercial

and industrial consumers) is regulated by NERC; as such the general public does not feel the impact of the cost variations as per the different generation sources.

Typically, under the MYTO (Multi Year Tariff Order), NERC is determined to bear the additional cost of ₦5/kWh (\$ 0.042/kWh) increment on the electricity tariff which is now placed at ₦11/kWh against the previous price of ₦6/kWh before July 1, 2008. The public will only pay this new tariff rate after three years, 2011, when the government would have ensured an appreciable increase in the MW output of the Nigerian power sector. [Daily Sun, 2008]

#### **4.3.1.3 Clean Coal Technology**

Technology growth and development has been the trend for industrialization. The need to control CO<sub>2</sub> emission from coal power stations has seen various technology approaches/applications for its realization. Some of the technologies have been fully developed to maturity with commissioned plants available for validation while others are at their primal stages of study or validation.

##### **Existing coal stations**

For existing power stations, the options of CO<sub>2</sub> emission control are limited to retrofit technologies of adding CO<sub>2</sub> absorbers on flue gas path and complete combustion re-configuration. The later entails substituting air with pure oxygen for combustion of the coal and managing the heat/mass flow of the entire system.

Fluor Daniel has done much work on improving the MEA (monoethanolamine) based CO<sub>2</sub> absorption system, thus the Econamine FG system. It has the capacity to capture more than 90% of the CO<sub>2</sub> entrained in flue gases.

### **New Coal stations**

Improving the thermal efficiency of the coal combustion system has a direct impact on its CO<sub>2</sub> emission reduction as discussed in literature survey (2.2.4). The advancement in Pulverized coal technology has seen the state-of-the-art ultra-supercritical and supercritical steam cycles being preferred to the subcritical steam cycle PC plants. An efficiency range of 43 - 48% is achievable with the new ultra-supercritical steam cycle with a consequent CO<sub>2</sub> emission reduction of 10 – 15%. [Kraemer & Beck, 2006]

Integrated gasification combined cycle IGCC also has significant improvement in efficiency and emission reduction compared to the traditional pulverized coal plant technology. IGCC plants share the same efficiency range with ultra-supercritical steam cycles PC plants.

However, the selection of clean coal generation technologies in an economy is a rigorous iterative process that depends on many factors, they include:

1. Capital investment cost
2. Operating and maintenance costs
3. Overall energy efficiency

4. Fuel prices
5. Cost of electricity (COE)
6. Availability, reliability and environmental performance
7. Current and potential pollution/emission regulations
8. Clean coal technologies maturity and commercial-scale demonstrations

The combination of these factors will have to be worked out at an optimum point necessary to close down on the most viable option.

For cost and performance evaluation of some of these clean coal technologies on existing plants, *see the works of Simbeck, D. (2001) and Vogel et al, (2001) for further reading.*

#### **4.3.1.4 Economy of Scale**

Economy of scale is a tool that lends credence to the economic viability of an option under certain conditions. Generally speaking, economy of scale refers to the understanding of increasing cost efficiency of production of goods/services as the number of goods/services being produced increases. For coal power facilities, the idea of economy of scale is well applied. The unit cost of electricity generated drops appreciably as the total units generated increases. For this reason it is better to build higher capacity coal power stations than smaller scale as the case usually is for gas turbine generators. The figure 4.16 below models the cost-delta of subcritical pulverized coal plants, showing economy of scale.

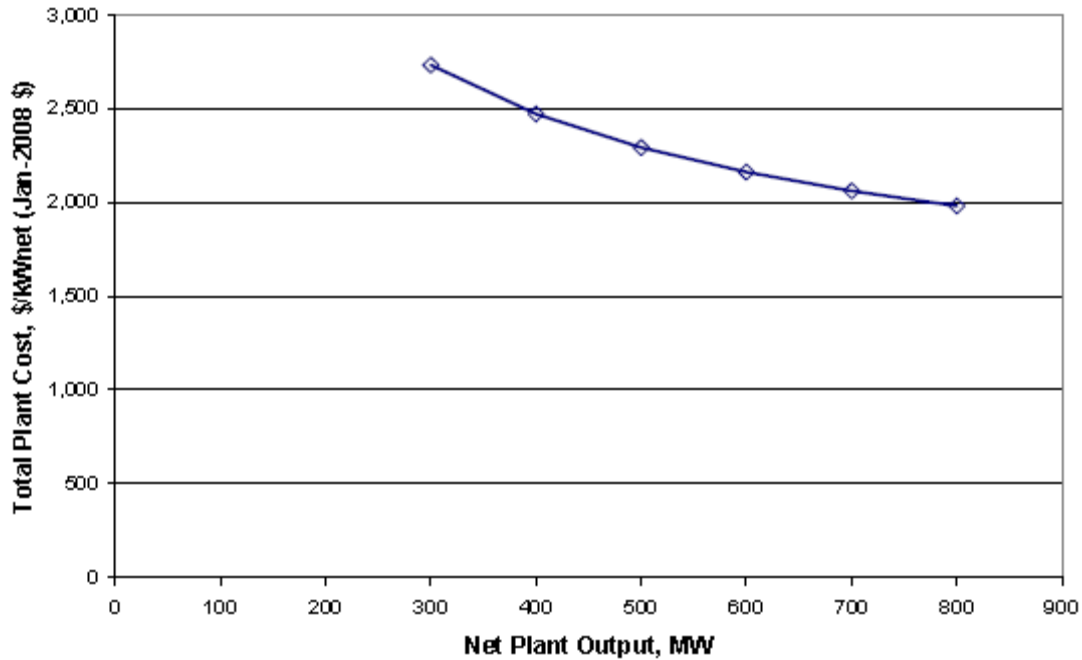

Figure 4.16 Estimated Subcritical PC Plant cost

[Source: EPRI PCCost Program as cited in ESMAP, 2008]

## 4.4 Validation of Results

In an attempt to test the correctness of the IECM-cs model used in cost estimation for the CO<sub>2</sub> mitigation analysis, the results obtained were checked against the work of International Energy Agency (IEA) on projected cost of electricity. The results of the IEA Projected Costs of Generating Electricity 2005 Update is an outcome of cost data gathered from more than 130 operational power plants around the world. The report covers different power generation technology applications in different countries. The charts (IEA) below summarize the levelized cost of electricity and overnight construction cost of coal-fired power stations. The results of the IECM-cs model validate the IEA data ranges.

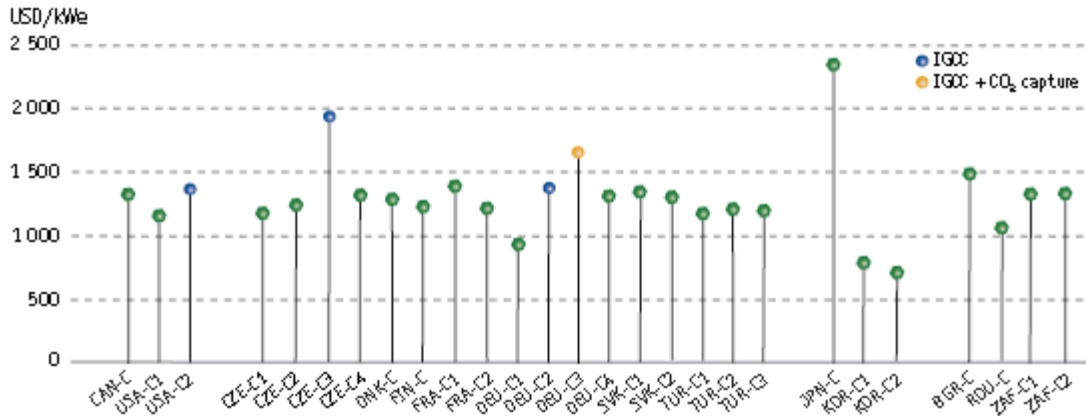

Figure 4.17 Specific overnight construction costs of coal-fired power plants

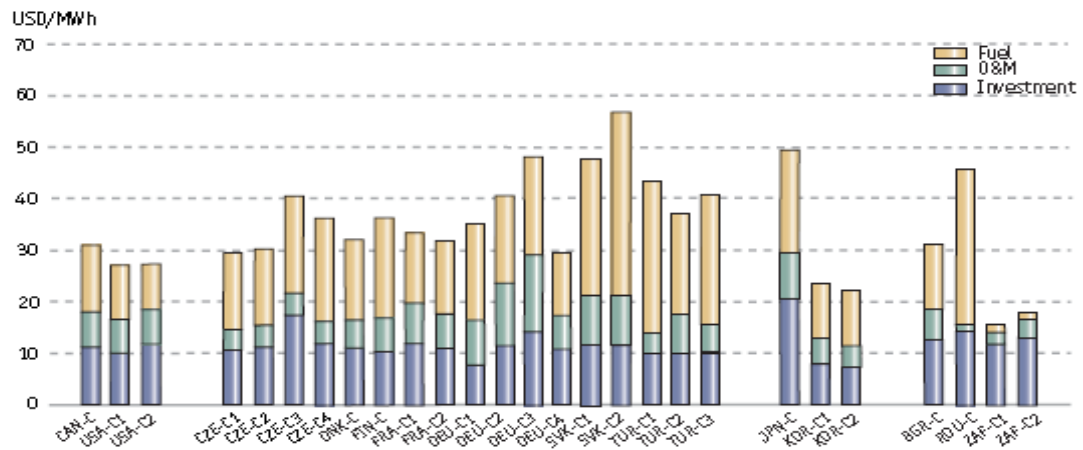

Figure 4.18 Levelized costs of coal generated electricity at 5% discount rate

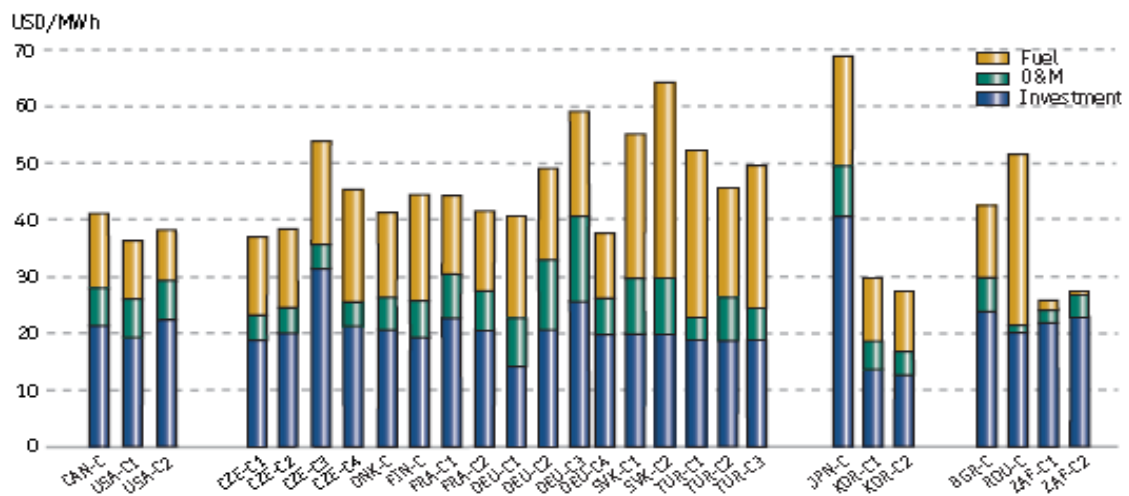

Figure 4.19 Levelized costs of coal generated electricity at 10% discount rate [Source: IEA, 2005]

## **GHG Emission Reduction**

Kyoto protocol was adopted in this study as the moving standard for checking the conformance of the power plants to GHG emissions control. Kyoto protocol is an outcome of more than 180 countries joint action plan under the United Nations Framework Convention on Climate Change (UNFCCC) to stabilize the concentration of greenhouse gases (GHG) in the atmosphere. This is borne out of the recognised need to combat global warming (climate change).

The retrofit analysis of the applied Amine (MEA-based) CO<sub>2</sub> capture and sequestration systems to the coal power stations showed a great score of compliance to the Kyoto protocol. Although Kyoto specifies cutting back emissions by a relative 5% mark, the MEA-based CO<sub>2</sub> emission control achieves above 90% emission reduction on existing power plant. This is a marked achievement in the pursuit of sustainable environment ideals.

The MEA-based emission control technology has attained a level of maturity over the years and has been widely tested and applied in various industries as a means of demonstrating its merits. The figure 4.20 below summarizes some of the notable applications of the MEA based CO<sub>2</sub> absorption system.

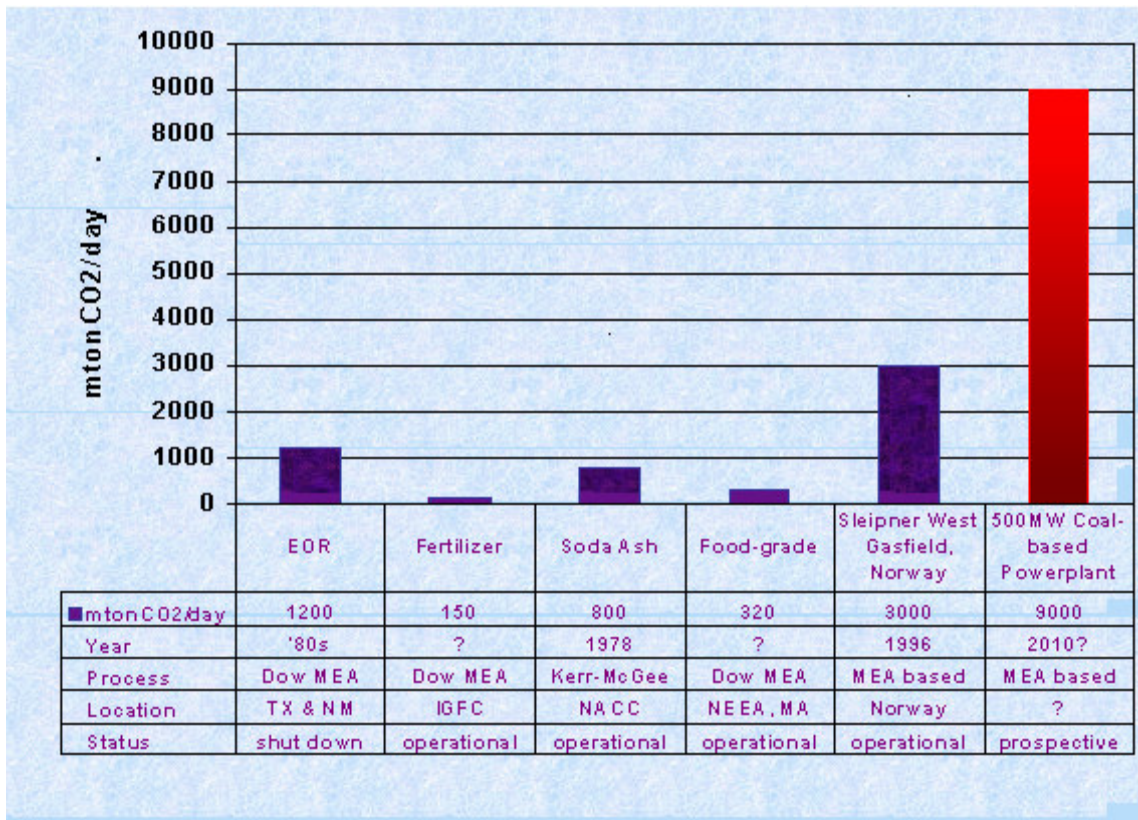

Figure 4.20 Industrial application of the MEA-based CO<sub>2</sub> Capture system

[Source: as cited in Rubin & Rao 2002]

## Summary

This chapter has dealt extensively with the presentation of field results gathered in the study, the results analyses and discussion. It showed the cost impact of doing CO<sub>2</sub> emission control on Nigerian coal power station and the bearing of this cost on the industry future.

The next chapter presents a brief overview of the work done and conclusions made based on the results established in this study. It will also submit a set of recommendations necessary for achieving the proposed solution (CO<sub>2</sub> emission control) while highlighting areas of further research as knowledge continuum.

## **CHAPTER FIVE**

### **CONCLUSION AND RECOMMENDATION**

#### **5.1 Conclusion**

##### **5.1.1 Introduction**

The growing demand for energy pulled by population growth and industrialization is an issue that requires proper management to ensure sustainable development. The need to stabilize and eventually reduce the concentration of greenhouse gases in atmosphere is a current challenge. Utilizing energy resources therefore requires a greater level of responsibility and commitment to environmental conservation. Coal as already discussed in the literature review (2.2.2.1), has huge environmental consequences when combusted in traditional steam boilers for power generation. The need to adjust positively in preserving the environment while using coal has led to recent research into the application of clean coal technology.

##### **5.1.2 Continued Coal Utilization**

As discussed in 4.3.1.1, the current emission level of carbon dioxide into the atmosphere from the Nigerian coal power stations is 100 percent. This emission rate does not comply with the specifications of the UNFCCC Kyoto protocol for greenhouse gases emission reduction.

Therefore, with the tightening situation for greenhouse gases emission regulation as championed by proponents of 'green environment', Kyoto protocol, the continued use of carbon intensive fuel is being challenged. As such, from an environmental integrity point of view, coal power stations will only have a future right of existence if their GHG emission is drastically reduced or eliminated.

However, implementing GHG emission control on coal power stations involve substantial capital outlay and may entail overall plant performance reduction. This additional cost factor needs to be justified economically in any economy for the sustained usage of coal to be upheld. Doing this will involve trade-off analysis in choosing the best scheme for realizing emission reduction in that economy.

### **5.1.3 The way forward for Nigerian Coal Power Stations**

As already discussed (2.2.3, 4.1.1), coal based power generation is almost non-existent in Nigeria, following the inoperable state of the existing Oji river power station. From a technical and economic point of view, Oji's capacity is small; it will cost a prohibitive amount to implement CO<sub>2</sub> mitigation measures on the plant. Add to this, the need to do major rehabilitation work (more cost) on the plant to bring it back online. More so, the age and technology implemented at the Oji power station will require many modifications to integrate the Amine (MEA) based CO<sub>2</sub> retrofit system. Consequently the upgrading of Oji river power station is not a viable economic option. Therefore, the emphasis should rather be on new coal power stations.

The future of the coal power stations in Nigeria can be viewed from two perspectives: a situation where the current national environmental standard is being retained and another where it is revised to classify CO<sub>2</sub> as a pollutant. In view of these two possible scenarios, the future as contemplated by the research reported in this dissertation holds the following.

### **5.1.3.1 Under the Current Standards**

Going by the current Nigerian standard, the national environmental protection regulation FEPA S.I.8/S.I.9; new coal power stations will be built without any obligation to control CO<sub>2</sub> emission. Though, as discussed (4.3.1.1), under the current implementation window (2008-2012) of the Kyoto protocol, developing countries are not obliged to reduce emission of GHGs. The effect of this will be an overall increase of the Nigerian carbon footprint in the interim. However, the post 2012 implementation of Kyoto protocol may require otherwise for developing countries, and as such there may be a hurried need to do emission control.

A good action plan following this scenario will be, to build modern large capacity pulverized coal-fired power plants with improved steam cycles. Such plants have the capacity to be retrofitted easily in future with minimal modifications to capture CO<sub>2</sub> emission. But this will be at a cost as discussed in section 4.2.2, CO<sub>2</sub> mitigation economics

### **5.1.3.2 The Reviewed Standards**

With Nigeria's acceptance of the Kyoto protocol and its subscription to the idea of sustainable development as highlighted in 1.2 and discussed in 4.3.1.1, Nigeria will develop extensive programmes for the pursuit of sustainable environment. In view of this, the regulation of CO<sub>2</sub> will become enshrined in its national environmental standards.

The effect of a revised standard will mean that new coal power stations will be obliged to control CO<sub>2</sub> emission. The bearing of this will be such that investors will integrate CO<sub>2</sub> capture and sequestration into the choice of their plant from the planning stages of the investment. This path will not limit the choice of emission control to retrofits (after-thoughts) and it is more cost-efficient as there exists technology approaches that have integrated emission control.

More so, following the operation of the Kyoto protocol, Nigeria stands to gain some advantages by building 'CO<sub>2</sub>-ready' power plants. As highlighted (2.1.5) and discussed under the Kyoto mechanism in section 4.3.1.1; the Kyoto protocol's clean development mechanism (CDM), permits industrialized nations to generate emission credits by investing in sustainable development projects which reduce emissions in developing countries. Potential coal power station projects in Nigeria can be beneficiary under this CDM scheme. Also, with the future expansion of the Kyoto emission trading scheme to non-Annex 1 parties, Nigeria can gain foreign exchange by participating.

Carbon dioxide (CO<sub>2</sub>) once captured can be used for other economic purposes; however its usage will determine the kind of treatment it will require. For example, as the Nigerian oil wells deplete, pressurized CO<sub>2</sub> will become handy for enhanced oil recovery activities in line with literature review on CCS (2.2.4.1)

## **5.2 Recommendation**

### **5.2.1 Government Policy**

In view of the Nigerian electricity supply gap and the need to mobilize its energy resources for expanded power generation following ECN projections (table 4.3), coal-based power is an option. In the use of coal for power generation while considering the negative impacts of increased global warming the Nigerian government should engage a new policy framework. The policy should be directed towards the use of clean coal technologies in power generation to achieve greenhouse gas emission reductions.

The policy guidelines to be used should include:

- specifying emission limits for CO<sub>2</sub> from coal power stations
- putting a price on carbon emission
- removing barriers to behavioral change by introducing continuous emission monitoring systems
- and granting of extended tax holiday period to encourage massive investment

To achieve a sustainable use of coal for power generation, the current national environmental protection regulation standard will have to be reviewed to accommodate the above listed. Also an implementation arm should be set up by the government to monitor the compliance of the coal power plants.

## **5.2.2 Other Recommendations**

Following the operation of the Nigerian grid system for generated power distribution as discussed in 4.3.1.2 and the economy of scale idea (4.3.1.4), the government should encourage the building of high capacity coal power stations. And also, these new coal power stations should be meant to serve for baseload purposes on the grid.

## **5.2.3 Further Research**

This research study has succeeded in showing the incremental cost index of using Nigerian coal for power generation under the need for CO<sub>2</sub> emission control using commercially available Amine (MEA) based capture and sequestration system.

More research work needs to be done in determining the cost profiles of implementing other candidate clean coal technologies and their impact on the unit cost of electricity generated. This will present the best judgement parameters

for the most suited approach to be adopted for doing CO<sub>2</sub> emission control in Nigerian coal power station.

The cost of electricity generated from coal in Nigeria is relatively high compared to other countries. This is due to the current high price of coal in the Nigerian market. To foster price reduction for the coal feedstock, more research needs to be done on the coal mining processes.

In line with building new coal power plants, more work has to be done in selecting the plant sites. This is in view of the need to consider the location of the Nigerian coal fields, access to the electricity distribution network, nearness to CO<sub>2</sub> sequestration sites and proximity to densely populated areas to be supplied. Also further research has to be carried out in selecting the oil fields, geological sites and formations in order to enhance proper sequestration of the CO<sub>2</sub> captured. The choice of sequestration sites should also be made as to reduce the cost of transporting the CO<sub>2</sub>. An extension of this research is to find other useful applications/markets for the CO<sub>2</sub> captured.

## Appendix A - NIGERIAN COAL PRODUCTION HISTORY

### Coal Production in Nigeria, 1916 - 2002 (Tonnes)

Year	Production	Year	Production	Year	Production
1916	25,511	1945	314,576	1974	277,753
1917	83,405	1946	607,652	1975	271,397
1918	145,400	1947	572,354	1976	282,729
1919	137,844	1948	607,759	1977	243,318
1920	180,122	1949	550,517	1978	201,601
1921	187,027	1950	583,425	1979	163,000
1922	194,073	1951	562,270	1980	118,317
1923	112,818	1952	613,374	1981	114,812
1924	175,137	1953	679,437	1982	56,017
1925	220,161	1954	675,919	1983	52,730
1926	242,583	1955	750,058	1984	83,461
1927	353,274	1956	790,030	1985	139,744
1928	345,303	1957	846,526	1986	144,411
1929	363,743	1958	905,397	1987	110,161
1930	347,115	1959	684,800	1988	82,487
1931	327,681	1960	565,681	1989	80,973
1932	263,548	1961	596,502	1990	77,502
1933	259,860	1962	615,681	1991	100,074
1934	234,296	1963	600,229	1992	55,855
1935	258,892	1964	698,562	1993	27,686
1936	257,289	1965	730,183	1994	13,153
1937	310,308	1966	630,126	1995	19,505
1938	323,266	1967	Civil War	1996	18,374
1939	300,091	1968	Civil War	1997	17,797
1940	318,594	1969	Civil War	1998	11,934
1941	402,640	1970	24,404	1999	13,621
1942	463,978	1971	176,927	2000	10,668
1943	528,421	1972	323,007	2001	2,800
1944	668,158	1973	314,457	2002	2,480

[Source: Nigerian Coal Corporation statistics]

## Nigeria's Average Annual Coal Production

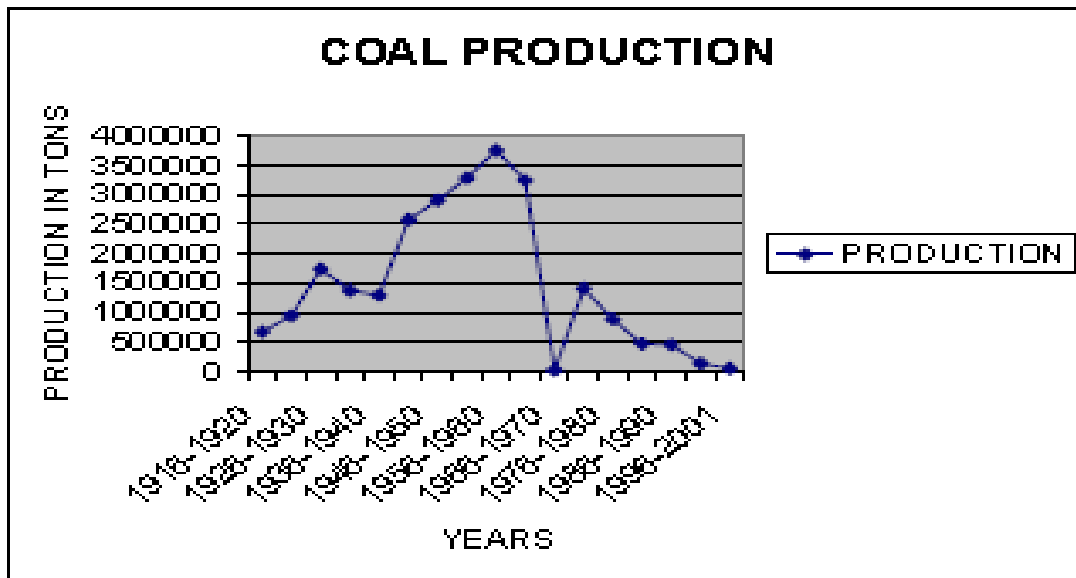

## Appendix B - NIGERIAN COAL AND LIGNITE DEPOSITS

### Predominant Coal regions in Nigeria

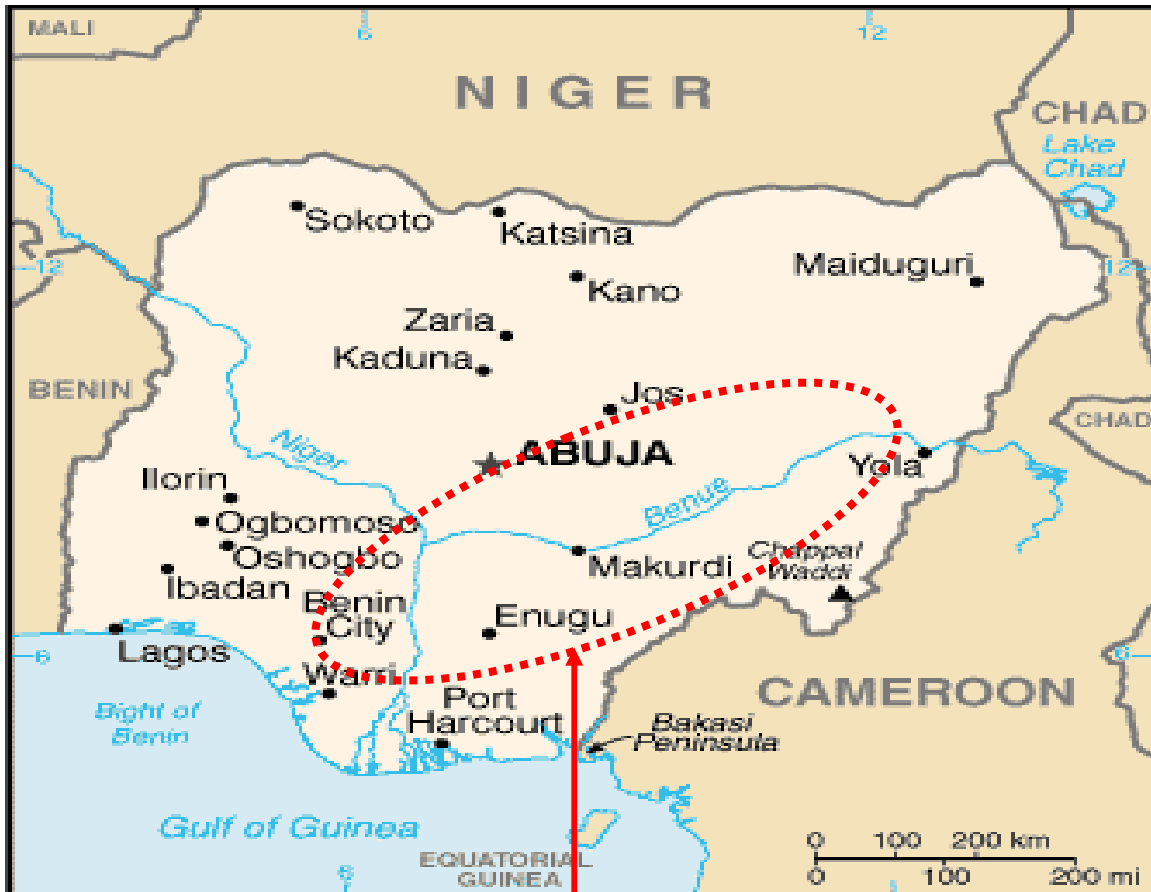

Source: CIA maps

Nigerian coal deposits are located predominantly within this circle

The map is adapted from [<http://geography.about.com/library/cia/blcnigeria.htm>]

## Nigerian Coal and Lignite Bearing Areas

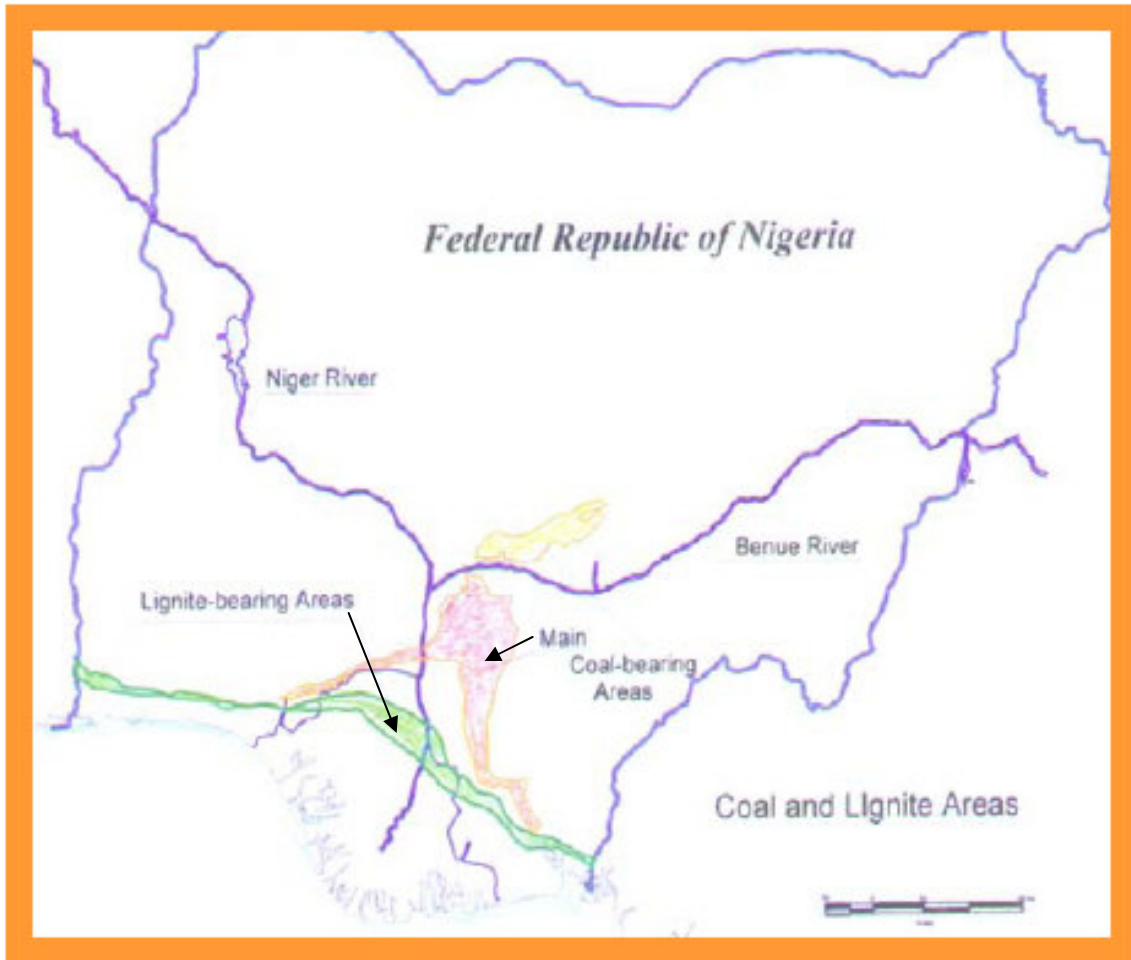

[Source: MSMD, 2006a]

## Appendix C - NIGERIAN POTENTIAL CO<sub>2</sub> SEQUESTRATION SITES

### Potential Enhanced Oil Recovery Sites

Map: Niger Delta Oil Infrastructure

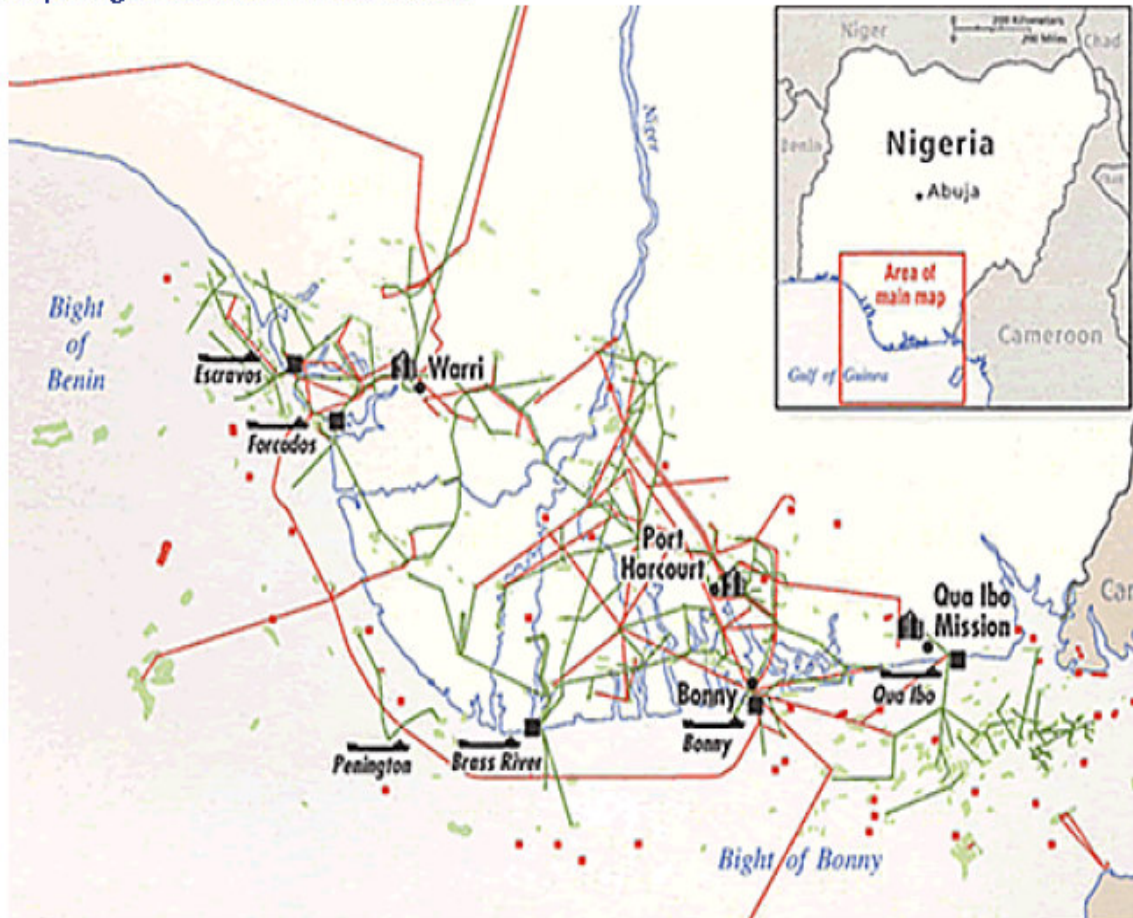

Source: CIA maps

## Bibliography

**APS**, 2007. NIGERIA - Part 2 - The Oil & Gas Fields and Foreign Operators, APS Review - Oil Market Trends, August 6, 2007. Available from: <http://www.entrepreneur.com/tradejournals/article/167520418.html> (Accessed 26 August 2008).

**Barrett et al**, 1971. Modern Power Station Practice – Mechanical (Boilers, Fuel and Ash Handling Plant) Vol. 2, Oxford, Pergamon Press, ISBN 0080160603

**Bellman D. K.**, 2007. Power Plant Efficiency Outlook - Working Document of the NPC Global Oil & Gas Study, July 18, 2007. Available from: <http://www.npc.org> (Accessed 1 March 2008).

**Berkenpas M. B., Fry J. J., Kietzke K., Rubin E. S.**, 2000. Integrated Environmental Control Model Tutorial: Prepared for the National Energy Technology Laboratory - U. S. Department of Energy, Pittsburgh, Center for Energy and Environmental Studies, Carnegie Mellon University. PA 15213.

**Bentley M. and Bersano C.**, 2007. Global Warming: University of St. Francis, Illinois, 60435 (800) 735-7500, Available from: <http://www.stfrancis.edu/ns/bromer/earthsci/student1/globalwarming.html> (Accessed 24 August 2007).

**Berlin K. and Sussman R. M.**, 2007. Global Warming and The Future Of Coal: The Path to Carbon Capture and Storage, Center for American Progress, May 31, 2007. [http://www.americanprogress.org/issues/2007/05/coal\\_report.html](http://www.americanprogress.org/issues/2007/05/coal_report.html) (Accessed 25 August 2007).

**Bolin B., Jager J., Doos B. R.**, 2007. Scope 29 - The Greenhouse Effect, Climatic Change, and Ecosystems: A Synthesis of Present Knowledge, Available from: <http://www.icsu-scope.org/downloadpubs/scope29/chapter01.html> (Accessed 5 February 2008).

**BPE** (Bureau of Public Enterprises), 2006. Federal Government of Nigeria - BPE Initiatives on Solid Minerals, Available from: <http://www.bpeng.org/CGI-BIN/NCC%20advert.doc> (Accessed 26 August 2008).

**Bradbrook A. J., Lyster R., Ottinger R. L., Xi W.**, 2005. The Law Of Energy For Sustainable Development, Cambridge University Press. ISBN 0521845254

**Chapel D., Mariz C., Ernest J.**, 1999. Recovery of CO<sub>2</sub> from Flue Gases: Commercial Trends, Originally presented at the Canadian Society of Chemical Engineers annual meeting October 4-6, 1999, Saskatoon Canada, Available from: [http://www.netl.doe.gov/publications/proceedings/01/carbon\\_seq/2b3.pdf](http://www.netl.doe.gov/publications/proceedings/01/carbon_seq/2b3.pdf) (Accessed 26 August 2008).

**Chevron Corporation**, 2007. Seven Principles of Addressing Climate Change, <http://www.chevron.com/globalissues/climatechange/sevenprinciples> (Accessed 11 February 2008)

**Coal Conference**, 2008. Senate Energy and Natural Resources Committee - Coal Conference March 10, 2008 - Natural Resources Defense Council, Available from: <http://www.energy.senate.gov/conference/Question1.doc> (Accessed 26 August 2008).

**ConocoPhillips**, 2007. Energy Guide, Available from: [http://www.conocophillips.com/social/energy\\_tomorrow/publicoutreach/guide/index.htm](http://www.conocophillips.com/social/energy_tomorrow/publicoutreach/guide/index.htm) (Accessed 13 February 2008).

**Daily Sun**, 2008. Sun News Publishing-The new electricity tariff, Available from: <http://www.sunnews.com/webpages/opinion/editorial/2008/may/12/editorial-12-05-2008> (Accessed 10 June 2008).

**EIA** (Energy Information Authority) 2006. Emissions of Greenhouse Gases in the United States 2006, DOE/EIA-0573(2006), Available from: [http://eia.doe.gov/oiaf/1605/ggrpt/pdf/0573\(2006\).pdf](http://eia.doe.gov/oiaf/1605/ggrpt/pdf/0573(2006).pdf) (Accessed 22 November 2007).

**EIA** (Energy Information Authority), 2007. Nigeria Energy Data, Statistics and Analysis - Oil, Gas, Electricity, Coal, Available from: <http://www.eia.doe.gov/emeu/cabs/Nigeria/Full.html> (Accessed 2 Feb. 2008).

**Ejiofor A**, 2008. NGC's 221 percent gas price increase, Available from: <http://www.businessdayonline.com/energy/14358.html> (Accessed 12 August 2008).

**ELAW** (Environmental Law Alliance Worldwide) 2008. Climate Justice: Enforcing Climate Change Law, <http://www.climatelaw.org/> (Accessed 26 August 2008).

**Elliot, L.**, 1998. The Global Politics of the Environment, UK, Macmillan Press Ltd.

**EPA** (Environmental Protection Agency) 2002. Greenhouse Gases And Global Warming Potential Values: Excerpt from the Inventory of U.S. Greenhouse Emissions and Sinks: 1990-2000, EPA 430-R-02-003, Available from: <http://www.epa.gov/globalwarming/publications/emissions> (Accessed 2 Feb 2008).

**EPA** (Environmental Protection Agency) 2006. Global Warming, Available from: <http://www.epa.gov/globalwarming/climate/index.html> (Accessed 19 Oct. 2007)

**EPA** (Environmental Protection Agency) 2008. Climate Change - Greenhouse Gas Emissions, Available from <http://epa.gov/climatechange/emissions/index.htm> (Accessed 31 January 2008).

**ESMAP** (Energy Sector management Assistance Program) 2008. Study of Equipment Prices in the Power Sector (Work in Progress), Available from: [http://esmap.org/filez/pubs/724200833229\\_power\\_prices.pdf](http://esmap.org/filez/pubs/724200833229_power_prices.pdf) (Accessed 2 August 2008)

**Eskom**, 2007. Partnering for Growth, Annual Report 2007, Available from: [www.eskom.co.za](http://www.eskom.co.za) (Accessed 15 February 2008).

**FEPA** (Federal Environmental Protection Agency) 1991. Federal Republic of Nigeria Official Gazette - National Environmental Protection Regulation: S.I.8 & S.I.9, Lagos, FGPL 211/991/12,000.

**Figueroa J. D., Fout T, Plasynski S, McIlvried H, Srivastava R. D.** 2007 Advances in CO<sub>2</sub> capture technology - The U.S. Department of Energy's Carbon Sequestration Program, International Journal of Greenhouse Gas control, Vol. 2, Elsevier Ltd

**Franz W. E.**, 1997. "The Development of an International Agenda for Climate Change: Connecting Science to Policy." International Institute for Applied Systems Analysis Interim Report IR-97-034/August, Available from: <http://www.iiasa.ac.at> (Accessed 26 August 2008).

**Gore A**, 2006. An Inconvenient Truth: The Planetary Emergency of Global Warming and What We can Do about it, London, Bloomsbury Publishing Plc, ISBN 0 7475 89062.

**Hawkins D. G.**, 2005. Coal and Global Warming, Natural Resources Defense Council, Submission to Senate Energy Committee, February 16, 2005, Available: <http://www.e2.org/ext/doc/hawkinscoal.pdf> (Accessed 29 January 2008).

**Howe A.**, 2007. The future of new coal-fired power stations: Position Statement, Available from: [www.environment-agency.gov.uk](http://www.environment-agency.gov.uk) (Accessed 22 March 2008).

**IEA** (International Energy Agency) 2004. World Energy Outlook, Available from: [https://www.iea.org/textbase/speech/2004/WEO2004\\_Electricity.pdf](https://www.iea.org/textbase/speech/2004/WEO2004_Electricity.pdf) (Accessed 12 February 2008).

**IEA** (International Energy Agency) 2005. IEA/OECD: Projected Costs of Generating Electricity 2005 Update, Paris, Head of Publications Service, 75739 Cedex 15, France.

**IPCC** (Intergovernmental Panel on Climate Change) **2001**. Climate Change 2001: The Scientific Basis. Contribution of Working Group I to the Third Assessment Report of the Intergovernmental Panel on Climate Change [Houghton, J.T., Ding Y., Griggs D.J., Noguer M., van der Linden P.J., Dai X.,

Maskell K., and Johnson C.A. (eds.]. Cambridge University Press, Cambridge, United Kingdom and New York, NY, USA.

**Iwuagwu L. C.**, 2004. Final Report on the Rehabilitation, Commissioning and Reliability Test of the Oji River Power Station Plant, Ref: 0646/264/003.

**Jeantheau M.** 2007. Climate Change vs. Global Warming, *Issue Number 166*  
Available from: <http://www.grinningplanet.com> (Accessed 3 February 2008).

**Jones M. L.**, 2007. CO<sub>2</sub> Separation and Capture: Status, Issues, and Opportunities, Presented At Carbon Capture And Sequestration Conference, Austin - Texas United States, November 13-15, 2007. Available from: <http://www.netl.doe.gov/technologies/coalpower/ewr/pubs/MLJ-Carbon-Capture-and-Storage-111307.pdf> (Accessed 13 May 2008).

**Keepin W., Mintzer I., Kristoferson L.**, 2007. Scope 29 - The Greenhouse Effect, Climatic Change, and Ecosystems: Emission of CO<sub>2</sub> into the Atmosphere, The Rate of Release of CO<sub>2</sub> as a Function of Future Energy Developments. Available from: <http://www.icsu-scope.org/downloadpubs/scope29/chapter02.html> (Accessed 5 February 2008).

**Kraemer T. G. and Beck R.A.** 2006. Coal: America's Energy Future, The National Coal Council, volume 1. 2006924747, Available from: [www.nationalcoalcouncil.org](http://www.nationalcoalcouncil.org) (Accessed 1 December 2006)

**Lee S.**, 1996. Alternative Fuels, Washington DC, Taylor & Francis, ISBN 1-56032-361-2.

**Lutgens F. K. and Tarbuck E. J.**, 2002. Foundations of Earth Science, 2nd ed. Upper Saddle River NJ, Prentice-Hall Inc.

**Manchester Metropolitan University**, 2007. Global Warming Potentials (GWPs) Available: [http://www.ace.mmu.ac.uk/eae/Global\\_Warming/Older/GWPs.html](http://www.ace.mmu.ac.uk/eae/Global_Warming/Older/GWPs.html) (Accessed 16 February 2008).

**Microsoft Encarta**, 2006. Microsoft Encarta Premium DVD Library, Redmond, WA 98052-6399 USA, Version 15.0.0.0603

**Miller B.G.**, 2005. Coal Energy Systems, California, Elsevier Academic Press, ISBN 0-12-497451-1

**Miller T. G. Jr**, 1996. Living in the Environment: Principles, connections and solutions, 9<sup>th</sup> Ed, Wadsworth Publishing Company, ISBN 0-534-23898

**MOE** (Ministry of Environment) 2003. Federal Republic of Nigeria: Nigeria's First National Communication Under The United Nations Framework Convention on Climate Change, Abuja, NIR/97/G31

**MSMD** (Ministry of Solid Minerals Development) 2006. Federal Republic of Nigeria: Ministry Of Solid Minerals Development and The Bureau Of Public Enterprises, Invitation For Expression Of Interest As Investor In Coal Properties

**MSMD** (Ministry Of Solid Minerals Development) 2006a. Federal Republic of Nigeria, Owukpa Coal Concession - Information Memorandum June 2006. Available from: <http://msmd.gov.ng/Okaba.pdf> (Accessed 12 February 2008)

**NEEDS** (National Economic Empowerment and Development Strategy) 2004. National Planning Commission, Nigerian National Economic Empowerment and Development Strategy, Abuja, Document 051904.qxd, March 2004.

**NCC** (Nigeria Coal Corporation) 2007. Federal Government Official Gazette

**Nyajo C. A.**, 2004. Special Event Diary (Generation Sector), NEPA News, ISSN 0331-3074

**Okolo H. C. and Mkpadi M. C.**, 1996. Nigerian Coal: A resource for Energy and Investments, Lagos, Mufadenic Nig Ltd, ISBN 978-2043-23-0

**Rao A.B.**, 2002. Details of A Technical, Economic and Environmental Assessment of Amine-based CO<sub>2</sub> Capture Technology for Power Plant Greenhouse Gas Control, U.S. Department of Energy, DE-FC26-00NT40935

**Rubin E.S. and Rao A.B.**, 2002. A Technical, Economic and Environmental Assessment of Amine-based CO<sub>2</sub> Capture Technology for Power Plant Greenhouse Gas Control- Annual Technical Progress Report, DOE/DE-FC26-00NT40935. Available from: [http://www.iecm-online.com/documentation/tech\\_01\\_B.pdf](http://www.iecm-online.com/documentation/tech_01_B.pdf) (Accessed 16 June 2008).

**Rubin E.S.**, 2007. A New Virtual Engineering Tool for Modeling Advanced Power Plants with Near-Zero Emissions- Paper Presented at the Sixth Annual Carbon Capture and Sequestration Conference Pittsburgh, Pennsylvania. May 8, 2007

**Sambo A. S., Iloeje O. C., Ojosu J. O., Olayande J. S., Yusuf A. O.**, 2006. Nigeria's Experience On The Application Of IAEA's Energy Models (MAED & WASP) For National Energy Planning, Energy Commission of Nigeria, Paper presented during the Training Meeting / Workshop on Exchange of Experience in Using IAEA's Energy Models and Assessment of Further Training Needs, held at the Korea Atomic Energy Research Institute, Daejeon, Republic of Korea, 24 – 28 April, 2006

**SCOPE 29**, 2008. The Greenhouse Effect, Climatic Change, and Ecosystems - The Assessment of the Role of Carbon dioxide and of other Greenhouse Gases in Climate Variations and Associated Impacts Villach, Austria, 9-15 October

1985, Available: <http://www.icsu-scope.org/downloadpubs/scope29/statement.html> (Accessed 16 February 2008).

**Simbeck D**, 2001. CO<sub>2</sub> Mitigation Economics For Existing Coal-Fired Power Plants, Presented at the US Dept. of Energy National Energy Technology Laboratory (NETL), First National Conference on Carbon Sequestration, Washington DC May 14-17, 2001.

**Smith R**. 2007. Coal's Doubters Block New Wave of Power Plants. Wall Street Journal July 25, 2007. Available from: <http://news.mongabay.com/2007/0725-coal.html> (Accessed 25 August 2007).

**Smoot D. I. and Smith P. J.**, 1985. Coal Combustion and Gasification, New York, Plenum Press, ISBN 0-306-41750-2

**UN-NGLS** (United Nations Non-Governmental Liaison Service) 2000. UN News - Go Between 78, Dec. 1999 - Jan. 2000, Available from: <http://www.un-ngls.org/documents/pdf/go.between/gb78.pdf> (Accessed 26 August 2008).

**United Nations**, 1998. Kyoto Protocol to The United Nations Framework Convention On Climate Change.

**UNFCCC**, 2006. United Nations Framework Convention on Climate Change Handbook, Bonn, Germany: Climate Change Secretariat, ISBN: 92-9219-031-8

**UNFCCC** (United Nations Framework Convention On Climate Change), 2007. Kyoto Protocol Reference Manual on Accounting of Emissions and Assigned Amounts, UNFCCC secretariat.

**Vogel et al**, 2001. Technical And Economic Feasibility Of CO<sub>2</sub> Capture On An Existing Us Coal-Fired Power Plant, Presented at the 2001 International Joint Power Generation Conference, New Orleans, June 4-7, 2001. Available from: [http://www.netl.doe.gov/energy-analyses/pubs/CO<sub>2</sub>%20Retrofit%20From%20Existing%20Plants%20Revised%20November%202007.pdf](http://www.netl.doe.gov/energy-analyses/pubs/CO2%20Retrofit%20From%20Existing%20Plants%20Revised%20November%202007.pdf) (Accessed 4 June 2008).

**WCI** (World Coal Institute), 2008. The Coal Resource: A Comprehensive Overview of Coal, Cambridge House, 180 Upper Richmond Road, Putney, London SW15 2SH, UK. Available from: [http://www.worldcoal.org/assets\\_cm/files/PDF/howiscoalused.pdf](http://www.worldcoal.org/assets_cm/files/PDF/howiscoalused.pdf) (Accessed 10 June 2008).

**WCI** (World Coal Institute), 2008a. Coal: Meeting Global challenges, Cambridge House, 180 Upper Richmond Road, Putney, London SW15 2SH, UK. Available: <http://www.worldcoal.org/pages/content/index.asp> (Accessed 12 June 2008).

**WCI** (World Coal Institute), 2008b. Coal: Meeting the Climate Challenge, Available from:  
[http://www.worldcoal.org/assets\\_cm/files/PDF/coal\\_meeting\\_the\\_climate\\_challenge.pdf](http://www.worldcoal.org/assets_cm/files/PDF/coal_meeting_the_climate_challenge.pdf) (Accessed 26 August 2008).

**White C. M, Strazisar B. R, Granite E. J, Hoffman J. S, Pennline H. W**, 2003 Separation and Capture of CO<sub>2</sub> from Large Stationary Sources and Sequestration in Geological Formations - Coalbeds and Deep Saline Aquifers, Journal of the Air & Waste Management Association, June 2003 Issue. ISSN 1047-3289, 53:645–715

**Wikipedia**, 2007. Global warming, Available from:  
[http://en.wikipedia.org/wiki/Global\\_warming](http://en.wikipedia.org/wiki/Global_warming) (Accessed 26 August 2008).

**WMO** (World Meteorological Organisation) 1986. Report Of The International Conference On The Assessment Of The Role Of Carbon Dioxide And Of Other Greenhouse Gases In Climate Variations And Associated Impacts, Villach, Austria, 9-15 October 1985, WMO No.661