

Appendix A - List of assumptions

Steady-state simulations

Influence of temperature is negligible.

Heat exchanger central plane taken as symmetry plane.

Differential window-zone flow area in square and rotated triangular configurations is negligible.

Simulations are split into three separate sections.

Nozzle connections are omitted, as they have negligible influence.

Baffle rod supports are omitted, as they have negligible influence.

Baffle-shell and baffle-tube leakages are omitted.

Smooth wall roughness has negligible influence.

Convergence is reached when residuals and change in pressure drop fall below 10^{-3} and 0,1 Pascal per iteration, respectively.

Transient simulations

The geometry is simplified in order to lessen computational requirements.

The majority of the deposition of particles will be concentrated in the first four compartments and transportation of sediment downstream will only commence after significant deposits have already formed in the initial compartments.

A comparison of trends within simplified geometries will be sufficient.

Inlet velocity that is decreased, enhances convergence behaviour.

150 internal iterations sufficient to allow for general convergence

Sediment is modelled as fired clay.

Sediment inlet concentration is assumed to be 30%.

Particle size is assumed to be 1 mm.

Standard k- ϵ will have negligible discrepancies in accuracy.

Variables	
ΔP	33249.2
ΔP_Q	1432.214
ΔP_{QE}	2304.447
ΔP_F	3413.612
ΔP_S	997.561
N_u	6
$\Delta P_{Q,0}$	1432.214
f_L	1
f_B	1
ξ	0.483992
n_w	14
W_e	0.650978
ρ	997.561
V	0.14522
A_E	0.22308
S	0.858
L_E	0.26
d_s	0.43
A_{inlet}	0.14522
e	0.007
e_t	0.024
e_c	0.022
a	1.28
b	1.108513
s_q	0.032
s_t	0.027713
d_a	0.025
D_i	0.91
n_{tubes}	26
ξ_j	0.012227
ξ_t	0.471765
$f_{z,l}$	1
$f_{z,t}$	1
Re	18267.77
$f_{a,l,v}$	223.3609
$f_{a,t,v}$	5.484626
η	0.000889
η_w	0.000889
R_M	0.231714
R_L	0.079708
A_{SMU}	0.00412
A_{SG}	0.017781
A_{SRU}	0.013661
n	556
n_f	256
d_B	0.0258
D_L	0.9055
Y_{Rad}	2.248605
Y_{Deg}	128.8356
H	0.25725
r	0.615243
β	3.7
R_B	0
R_S	0
A_B	0
D_B	0.890647
S_E	0.89
n_{WE}	24
$\Delta P_{QE,0}$	2304.447
$A_{E,E}$	0.2314
$W_{e,E}$	0.627572
Re_E	17610.95
ξ_E	0.488787
$\xi_{E,E}$	0.012683
ξ_{IE}	0.476103
$f_{z,IE}$	1
$f_{z,IE}$	1
W_z	1.029629
n_{WF}	7.426168
d_g	0.032203
A_F	0.089173
U_F	11.07621
A_{FG}	0.152004
A_{FR}	0.062832
W_P	1.628528
ξ_S	2
W_S	1

Triangular	
ΔP	33249.2

Crossflow	
ΔP_Q	1432.214
$\Delta P_{Q,0}$	1432.214
W_e	0.650978
A_E	0.22308
A_{inlet}	0.14522
V	0.14522
a	1.28
b	1.108513
e	0.007
e_t	0.024
L_E	0.26
ξ_l	1.22E-02
ξ_t	0.471765
$f_{z,l}$	1.00E+00
$f_{z,t}$	1
Re	1.83E+04
$f_{a,l,v}$	223.3609
$f_{a,t,v}$	0.696263
$f_{a,t,v}$	5.484626
ξ_t	4.84E-01
ξ_v	4.84E-01
f_L	0.707826
f_B	1
R_M	0.231714
R_L	0.079708
A_{SMU}	0.00412
A_{SG}	0.017781
A_{SRU}	0.013661
γ	2.248605
r	0.615243
R_B	0
A_B	0
D_B	0.890647

Validity					
S/D	0.942857	Valid	t/d	1.28	Valid
H/D	0.282692	Valid	D/d	36.4	Valid
R_B	0	Valid	Re	18267.77	Valid

End Crossflow	
ΔP_{QE}	2304.447
$\Delta P_{QE,0}$	2304.447
$A_{E,E}$	0.2314
$W_{e,E}$	0.627572
Re_E	1.76E+04
$\xi_{E,f}$	0.488743
$\xi_{E,v}$	0.488787
ξ_{IE}	0.012683
ξ_{IE}	0.476103
$f_{z,IE}$	1
$f_{z,IE}$	1

Window	
ΔP_F	3413.612
n_{WF}	7.426168
d_g	0.032203
A_F	0.089173
U_F	11.07621
A_{FG}	0.152004
A_{FR}	0.062832
W_z	1.029629
W_P	1.628528

Nozzle	
ΔP_S	997.561
W_S	1

Appendix C

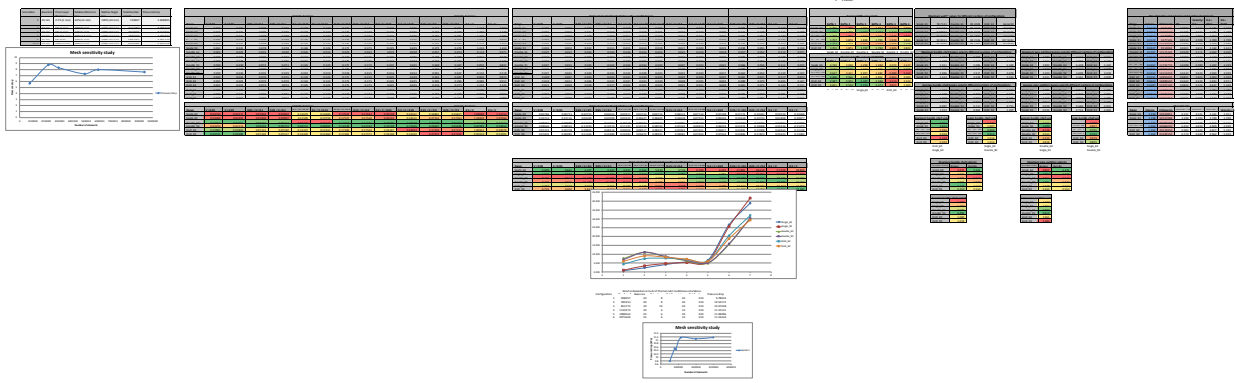

	BS	CF	PP	Out	Total	
s61	15.64	47.04	11.88	72.40	74.56	1.03
s62	21.32	38.99	12.24	72.55	72.55	1.00
s63	21.39	39.31	11.13	73.17	71.83	0.98
s91	13.83	45.54	13.83	72.40	73.19	1.01
s92	17.03	46.70	8.94	72.67	72.67	1.00
s93	16.60	47.14	7.77	72.90	71.51	0.98
D61	11.95	51.62	8.06	72.40	71.62	0.99
d62	20.92	38.26	11.34	72.59	70.52	0.97
d63	20.15	40.64	10.27	73.08	71.06	0.97
d91	9.75	57.17	7.45	72.40	74.36	1.03
d92	15.12	48.41	9.07	72.40	72.59	1.00
d93	8.52	55.84	8.77	72.41	73.13	1.01
dd61		63.67	8.50	72.43	72.18	1.00
dd62	0.00	62.88	10.13	72.78	73.01	1.00
dd63	0.00	59.08	13.52	72.65	72.60	1.00
dd91		67.58	5.15	72.40	72.73	1.00
dd92	0.00	64.52	6.65	72.26	71.17	0.98
dd93	0.00	63.16	9.13	72.25	72.29	1.00

BS	CF	PP
0.21	0.63	0.16
0.29	0.54	0.17
0.30	0.55	0.15
0.19	0.62	0.19
0.23	0.64	0.12
0.23	0.66	0.11
0.17	0.72	0.11
0.30	0.54	0.16
0.28	0.57	0.14
0.13	0.77	0.10
0.21	0.67	0.12
0.12	0.76	0.12
0.00	0.88	0.12
0.00	0.86	0.14
0.00	0.81	0.19
0.00	0.93	0.07
0.00	0.91	0.09
0.00	0.87	0.13

S60	26.7%	57.2%	16.1%
S90	21.8%	64.1%	14.0%
D60	24.9%	61.2%	13.9%
D90	15.2%	73.3%	11.5%
DD60	0.0%	85.2%	14.8%
DD90	0.0%	90.3%	9.7%

Total volume for threshold above the specified range														
Range	v<0.05	v<0.05	0.05<v<0.05	0.05<v<0.15	0.15<v<0.15	0.15<v<0.15	0.15<v<0.15	0.15<v<0.15	0.15<v<0.15	0.15<v<0.15	0.15<v<0.15			
Single_60	0.68970	0.66958	2.41878	2.39292	4.95181	4.16378	5.92966	5.71750	8.28931	6.99287	27.89076	26.81205	51.93992	38.89243
Single_90	1.94824	0.93163	11.03839	1.91204	4.84161	0.71761	0.02683	0.78817	0.01319	5.78119	27.25172	26.65345	53.99272	48.70209
Double_60	8.16931	7.61151	11.18994	11.02374	9.66431	6.56753	7.00894	6.21780	5.80228	4.83431	17.68848	15.52600	19.77486	30.46434
Double_90	7.48806	6.84271	12.24011	11.18486	10.82321	9.39980	7.90850	6.55110	5.80708	4.73772	18.83000	16.87650	18.86844	30.18890
DnD_60	4.74880	4.18251	8.03780	7.45480	6.18996	7.72524	7.05026	6.09760	6.58344	6.18751	22.66611	20.42241	12.24011	11.86165
DnD_90	6.74324	6.00161	8.81350	9.05184	8.90251	8.30830	7.72498	7.20112	6.53197	6.03444	21.93015	18.79218	18.86860	28.28377

Total percentage of volume of cells within specified velocity range						
Range	Single_60	Single_90	Double_60	Double_90	DnD_60	DnD_90
v<0.05	0.00070	0.04071	0.16031	0.40063	0.76669	0.76324
0.05<v<0.05	0.68958	0.93188	7.61158	6.92470	4.31676	0.05168
0.05<v<0.15	2.41878	2.39292	12.18994	12.24011	12.24011	8.81780
0.15<v<0.15	3.92966	3.82616	11.07074	11.06661	7.45480	0.01184
0.15<v<0.4	4.35138	4.94440	8.56839	9.62321	8.18996	9.02027
0.4<v<0.4	4.01978	4.71780	6.05051	6.20669	7.72824	8.30830
0.4<v<1	5.57995	5.51681	7.00586	7.56292	7.01010	7.72498
0.15<v<0.15	5.71390	6.39891	6.23786	6.05186	7.99780	7.20112
0.15<v<0.4	6.39891	6.02283	6.00830	5.80708	6.08861	6.51667
0.15<v<0.4	6.50687	5.78151	4.93439	5.17977	6.18751	6.03444
0.25<v<0.4	27.89076	27.25172	17.68848	18.83000	22.66611	21.93015
0.15<v<0.4	38.89243	38.84245	15.52600	15.87628	30.42241	18.79218
0.5<v<0.4	51.93992	51.93992	19.77486	18.86844	42.24011	38.86860
0.5<v<0.4	38.86860	41.71780	30.46434	30.31890	31.89165	28.28377

Total percentage of volume of cells within specified velocity range						
Range	Single_60	Single_90	Double_60	Double_90	DnD_60	DnD_90
v<0.05	0.005	0.111	0.151	0.534	0.450	0.792
0.05<v<0.05	0.114	0.327	1.114	1.144	0.583	0.820
0.15<v<0.15	0.188	0.228	1.027	0.914	0.462	0.524
0.15<v<0.4	0.212	0.237	0.501	0.765	0.403	0.524
0.2<v<0.4	0.198	0.231	0.688	0.687	0.403	0.498
0.25<v<0.4	0.278	0.268	1.113	0.765	0.244	0.268
0.5<v<0.4	13.072	8.821	8.170	6.584	10.358	9.573

Average baffles cut velocity (m/s)						
	Baffle 1	Baffle 2	Baffle 3	Baffle 4	Baffle 5	Baffle 6
Single_60	1.789	1.982	1.612	1.884	1.840	1.871
Single_90	1.168	1.028	1.254	1.279	1.284	1.278
Double_60	1.787	1.999	1.813	1.924	1.971	2.020
Double_90	1.757	1.870	1.818	1.799	1.820	1.843
DnD_60	1.727	1.818	1.813	1.824	1.905	1.793
DnD_90	1.751	1.875	1.747	1.782	1.905	1.821

Maximum baffles cut velocity (m/s)						
	Baffle 1	Baffle 2	Baffle 3	Baffle 4	Baffle 5	Baffle 6
Single_60	2.200	2.340	2.068	2.084	2.070	2.131
Single_90	2.624	2.550	3.022	2.886	2.690	2.758
Double_60	2.617	3.018	2.797	2.881	4.481	3.242
Double_90	2.680	2.560	2.828	2.893	4.261	3.061
DnD_60	2.397	2.501	2.307	2.586	3.113	3.122
DnD_90	2.621	2.610	2.270	2.679	4.621	2.926

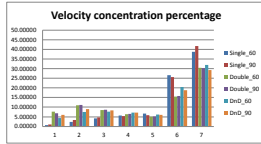

#Why does average Ruck20? - maybe combination of mass flow discrepancy and residual/convergence stuff
 #Why does maximum increase

the maxima of the double and disc and doughnut configs are not to be misinterpreted as good, look at SP to see low velocities on bottom

	P In	P Out	S In	S Out	T In	T Out
s61	-384.42	-7493.10	-7365.91	-10533.30	114.36	-5462.28
s62	12239.25	-1412.94	9199.56	1627.47	14262.31	550.90
s63	10550.18	-5.37	13590.11	6874.33	12509.49	907.87
s91	-316.05	-7483.20	-7044.27	-10514.16	182.73	-5826.33
s92	10553.82	-1422.80	7523.23	1607.41	12206.03	158.33
s93	10298.72	-11.47	13329.01	6697.43	11875.56	979.00
d61	-1603.72	-4454.04	-6252.11	-4454.17	-1104.94	-2385.14
d62	7717.21	-4429.73	7716.92	-4397.72	9786.08	-1641.26
d63	10349.83	-6.82	10380.63	4641.56	13133.35	1549.35
d91	-1450.51	-4456.12	-6098.89	-4456.09	-951.73	-2608.24
d92	7095.59	-4452.46	7096.11	-4445.16	8941.17	-1770.12
d93	9321.38	-0.79	9321.31	4647.60	12002.62	1377.61
dd61	-1565.67	-4454.67	-6214.06	-4455.23	-1066.89	-2731.41
dd62	6628.62	-4467.73	6628.41	-4467.97	8396.64	-1755.26
dd63	9772.03	-8.47	9771.74	4639.92	12471.85	1587.10
dd91	-918.41	-4454.58	-5566.79	-4454.41	-419.63	-2653.11
dd92	6991.24	-4470.63	6991.04	-4472.18	8793.06	-1809.97
dd93	9874.00	0.08	9872.61	4648.47	12529.79	1457.76

	Pressure	1	2	3
s6	31316.4	7108.7	13652.2	10555.5
D9	29454.0	7167.2	11976.6	10310.2
D6	25353.9	2850.3	12146.9	10356.7
D9	23875.8	3005.6	11548.0	9322.2
DD6	23765.8	2889.0	11096.3	9780.5
DD9	24872.0	3536.2	11461.9	9873.9

1664.51
2233.48

	Total	1	2	3
S6	30889.7	5576.6	13711.4	11601.6
D9	28953.3	6009.1	12047.7	10896.6
D6	24291.5	1280.2	11427.3	11584.0
D9	22992.8	1656.5	10711.3	10625.0
DD6	22701.2	1664.5	10151.9	10884.8
DD9	23908.5	2233.5	10603.0	11072.0

	Static	1	2	3
S6	17455.3	3167.4	7572.1	6715.8
D9	16017.3	3469.9	5915.8	6631.6
D6	16055.8	-1797.9	12114.6	5739.1
D9	14572.2	-1642.8	11541.3	4673.7
DD6	14469.4	-1758.8	11096.4	5131.8
DD9	15575.0	-1112.4	11463.2	5224.1

	Pressure	1	2	3
S6	29784.4	7108.7	13652.2	10555.5
D9	29454.0	7167.2	11976.6	10310.2
D6	25353.9	2850.3	12146.9	10356.7
D9	23875.8	3005.6	11548.0	9322.2
DD6	23765.8	2889.0	11096.3	9780.5
DD9	24872.0	3536.2	11461.9	9873.9

Correlation pressure drop [kPa]		
	G&G	Simulated
Single 60	33.249	30.88
Single 90	27.839	28.95

Percentage differences
7.10% 9.86%
-4.00% 3.33%

Dynamic	Total	Percentage Difference
16350.0	S6	30.89 -
16517.9	D9	28.95 93.73%
17118.1	D6	24.29 78.64%
15455.2	D9	22.99 74.44%
15534.1	DD6	22.70 73.49%
16538.4	DD9	23.91 77.40%

Surface Average of Pressure on Volume Mesh

Part	Value (Pa)
Body 01:00 Inlet	-3.84E+02
Body 01:00 Outlet	-7.49E+03
Total:	-3.10E+03

Surface Average of Total Pressure on Volume Mesh

Part	Value (Pa)
Body 01:00 Inlet	1.14E+02
Body 01:00 Outlet	-5.46E+03
Total:	-2.02E+03

.....

.....

.....

.....

.....

.....

.....

.....

.....

.....

.....

.....

.....

.....

[REDACTED]

[REDACTED]

[REDACTED]

[REDACTED]

[REDACTED]

Appendix D

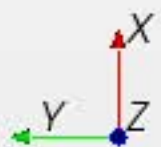
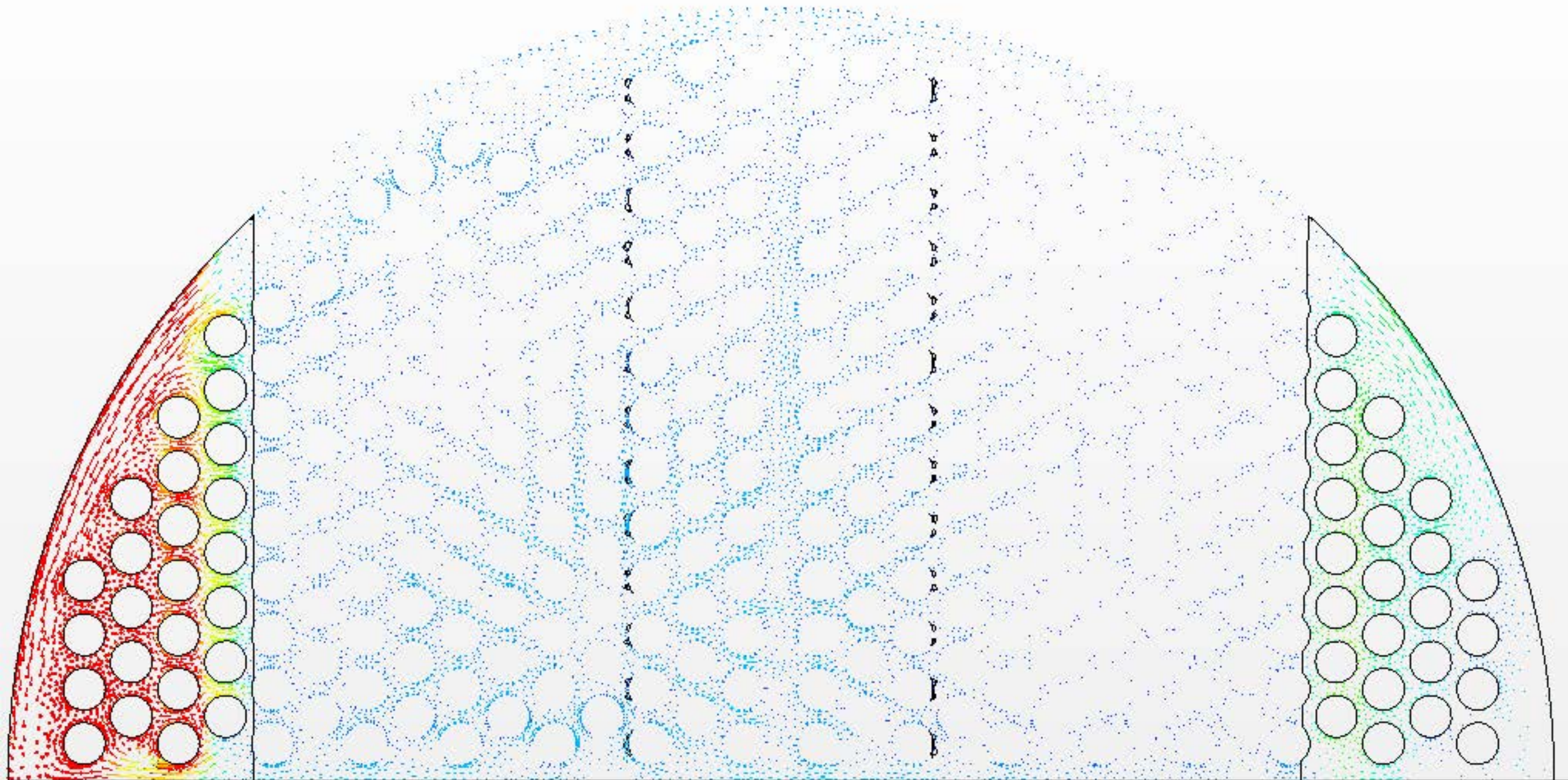

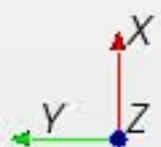
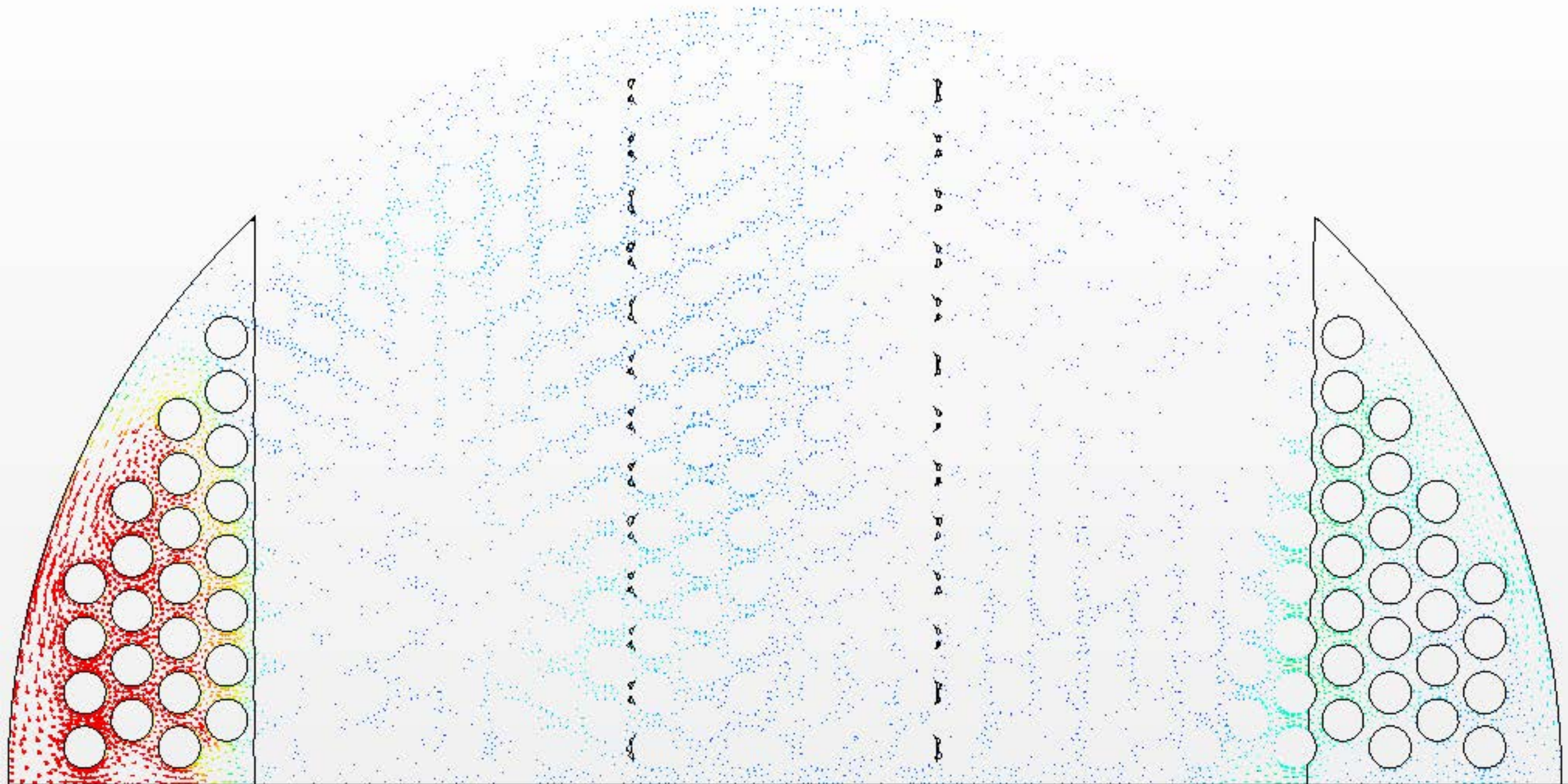

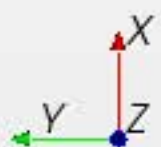
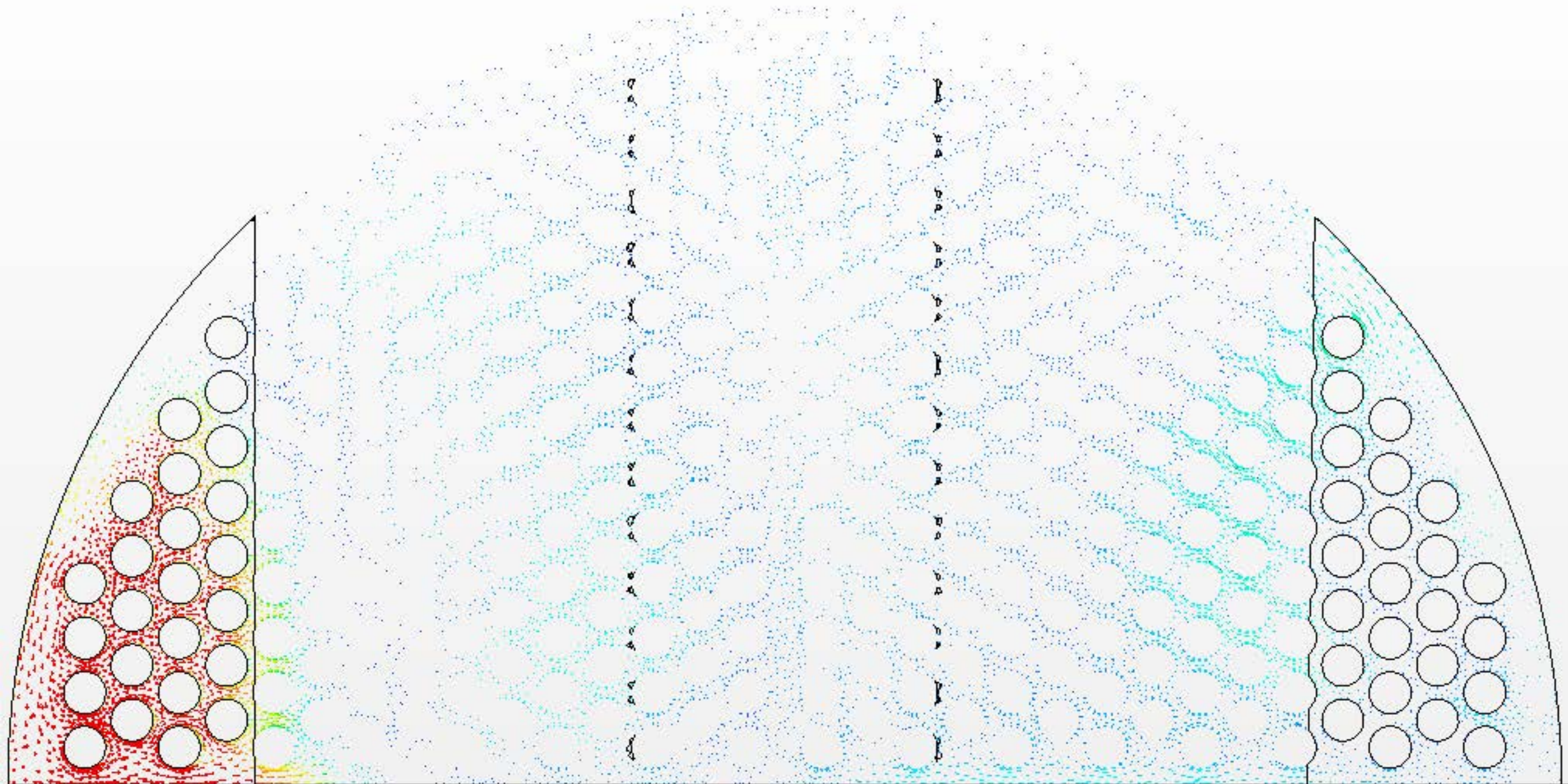

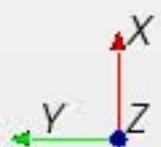
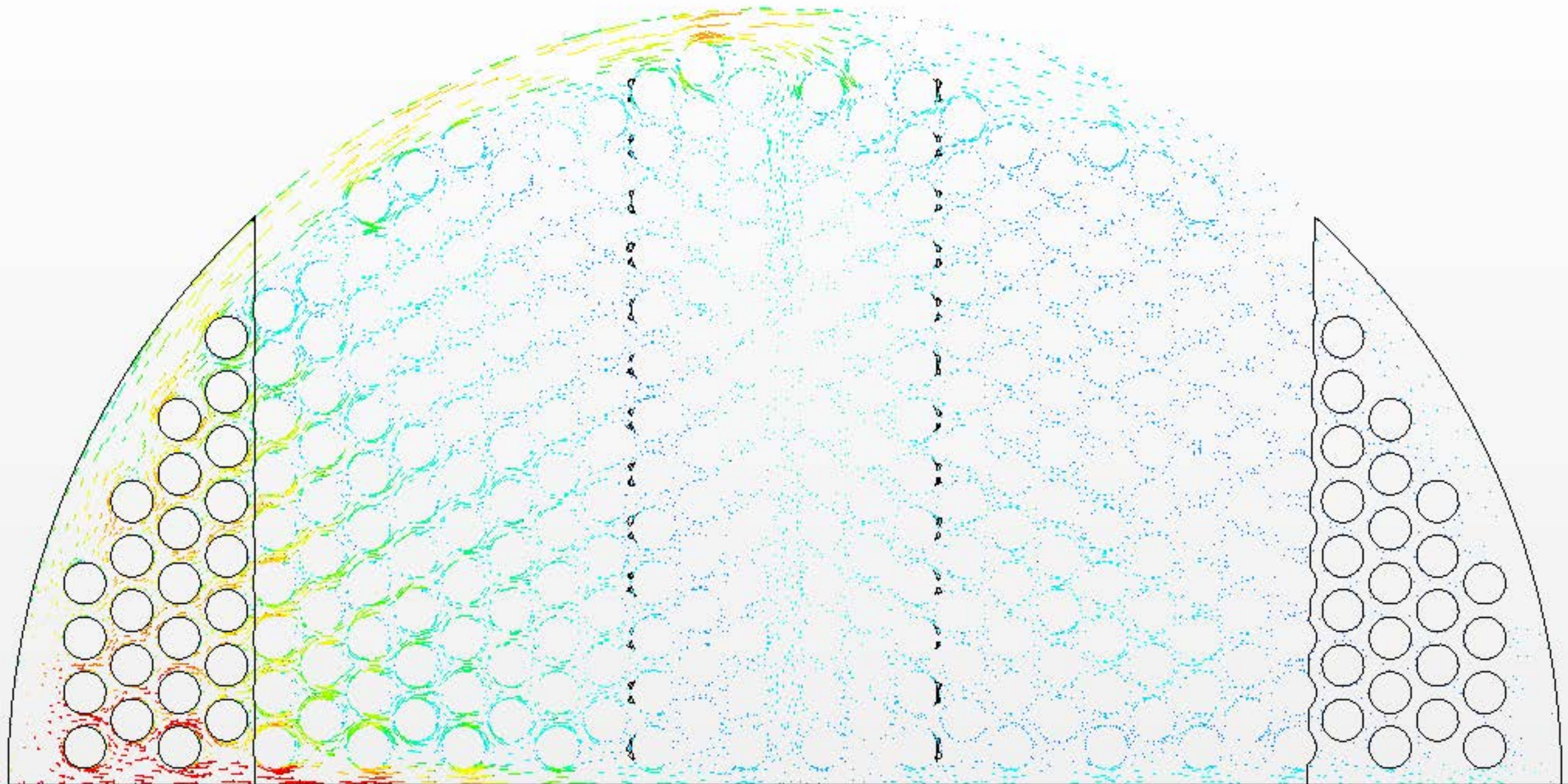

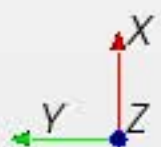
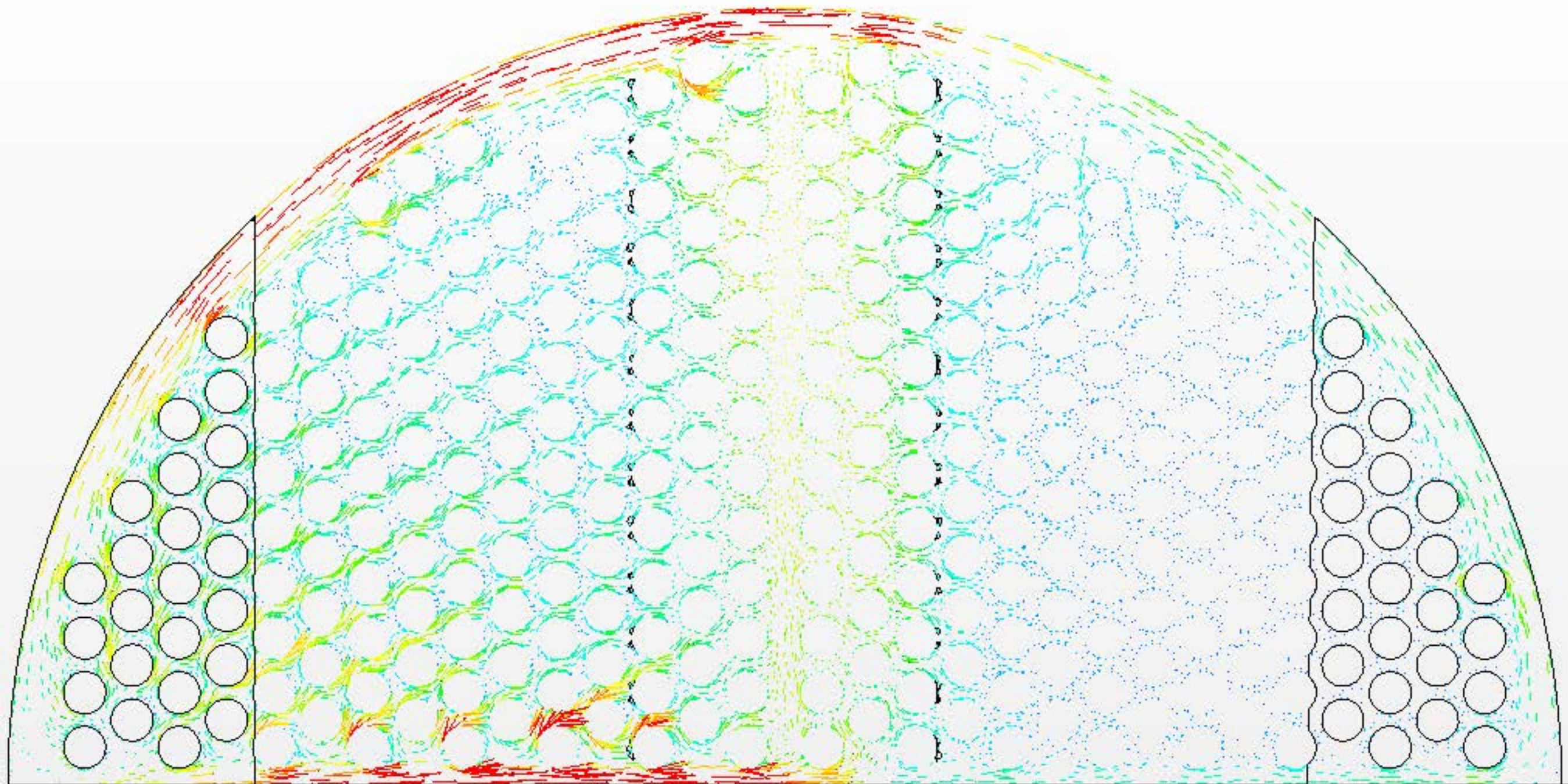

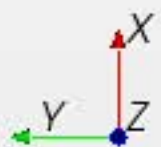
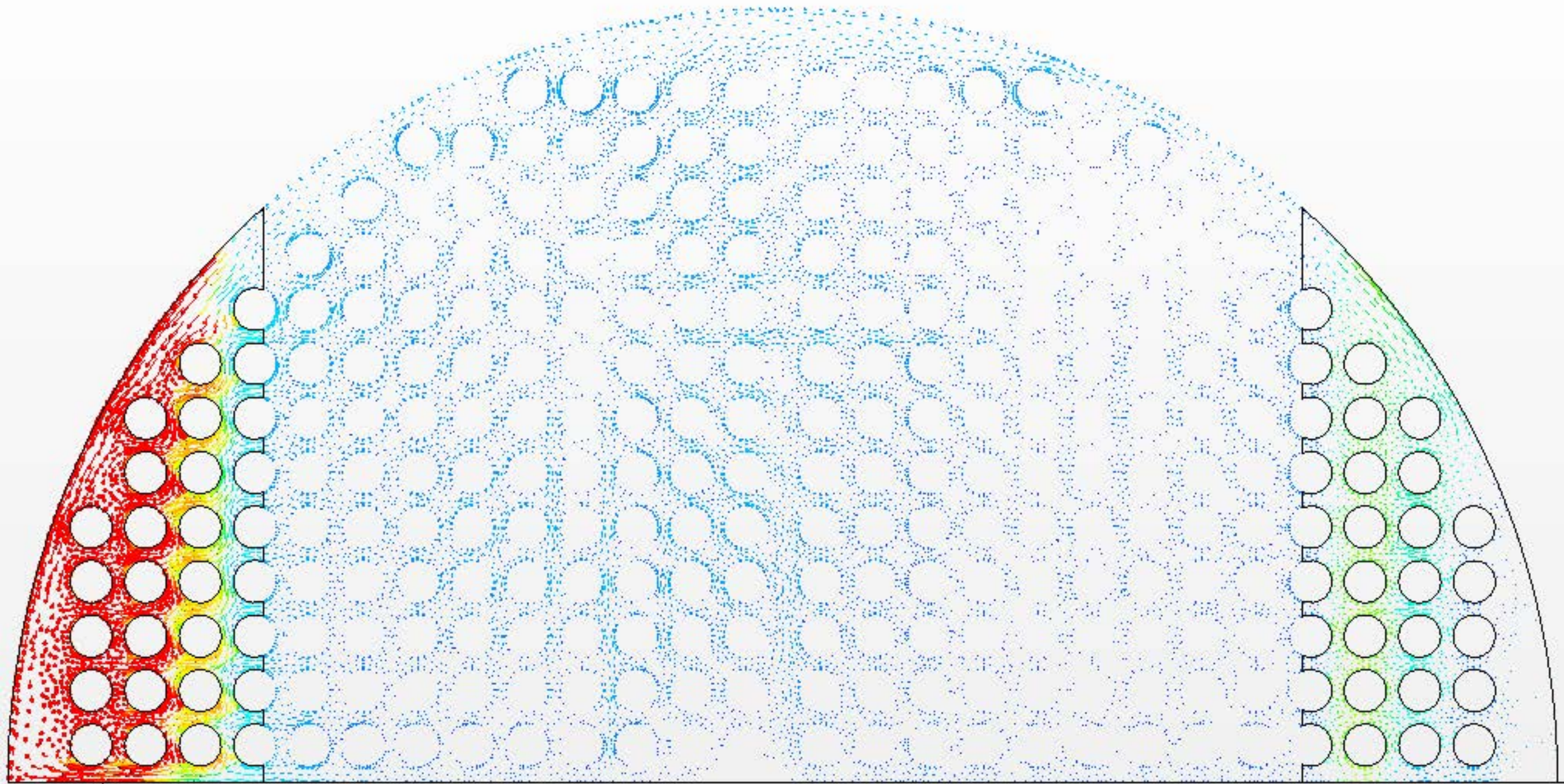

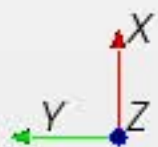
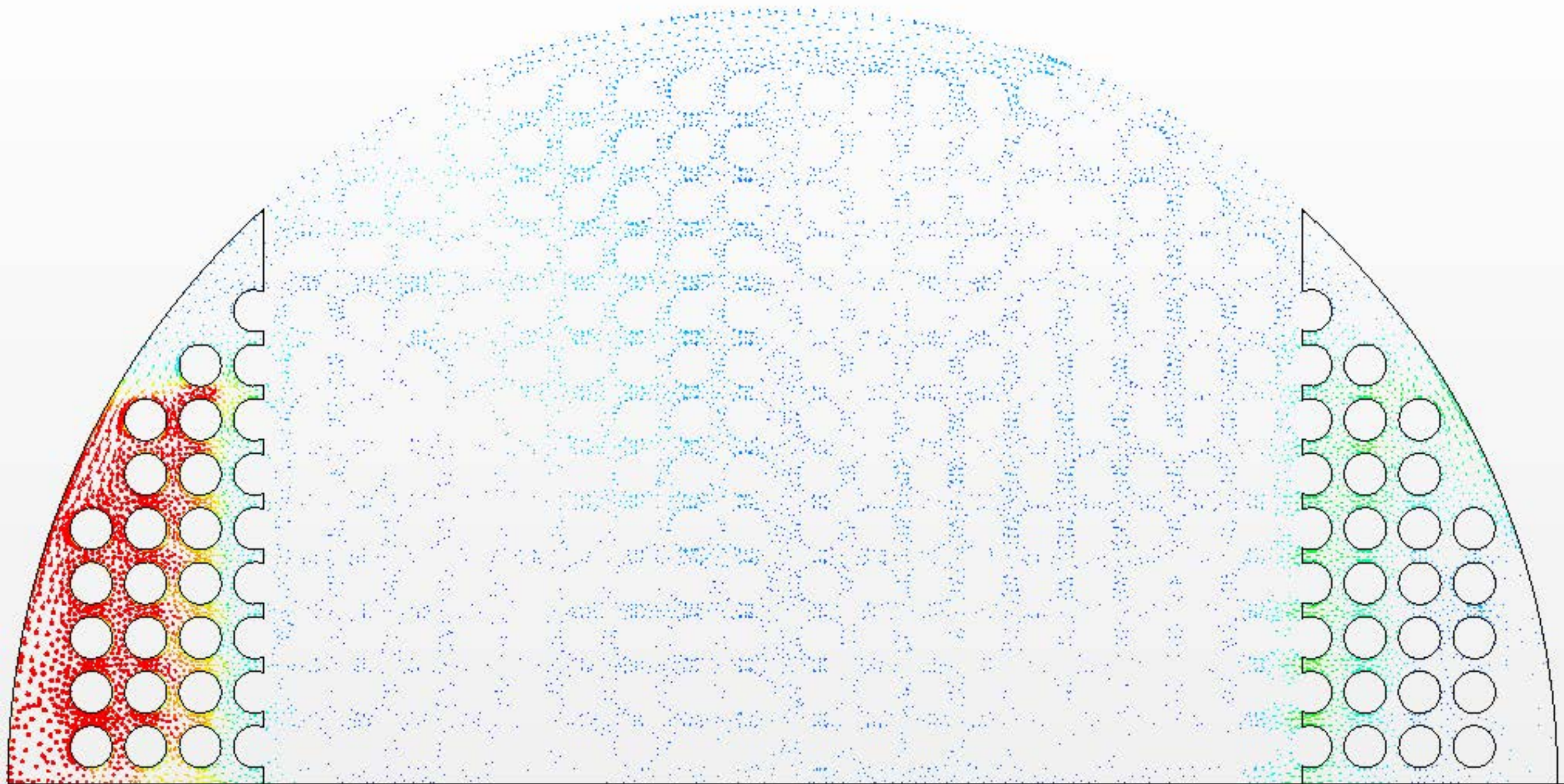

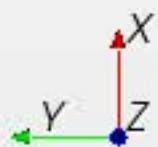
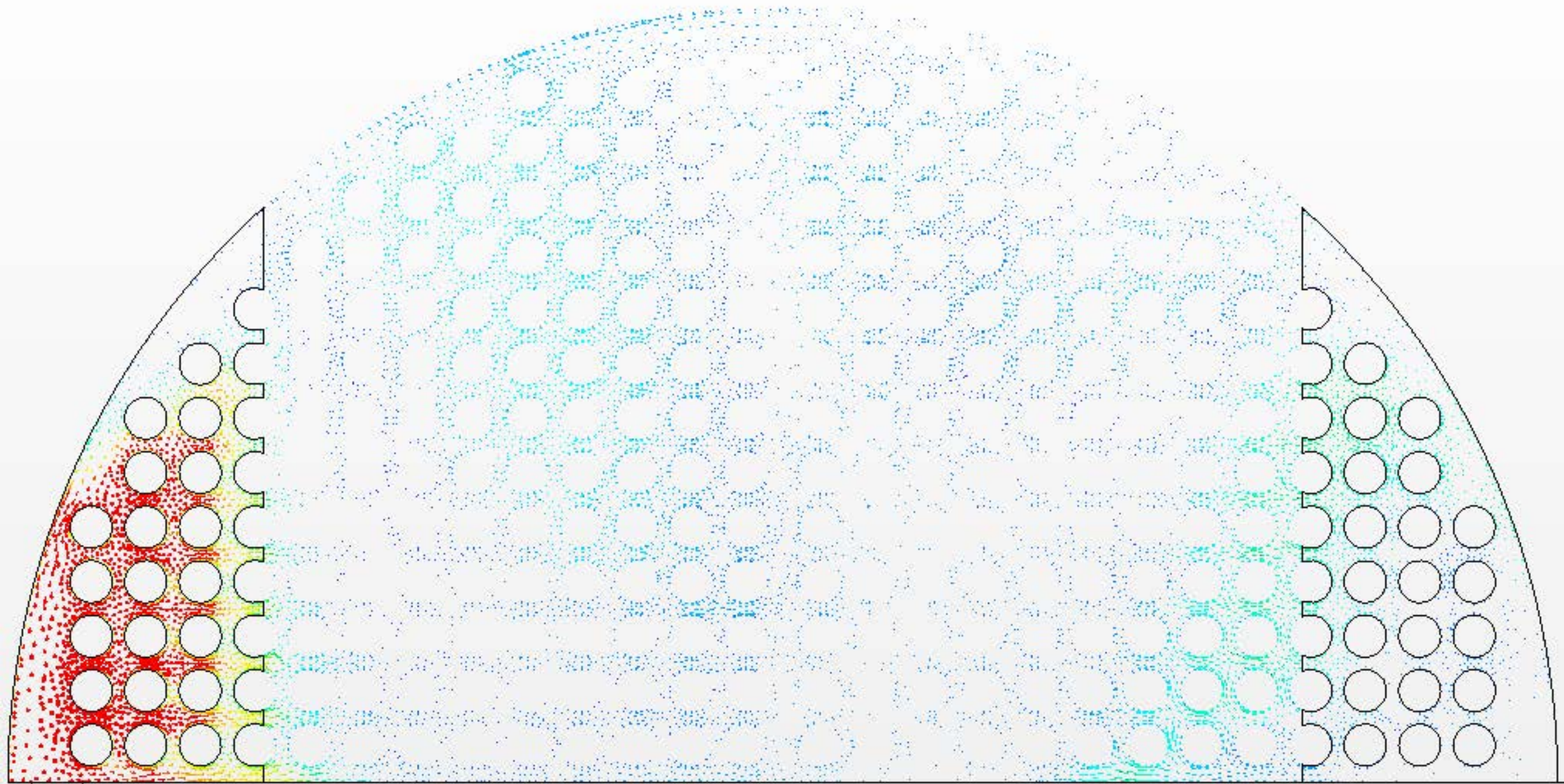

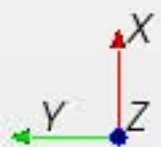
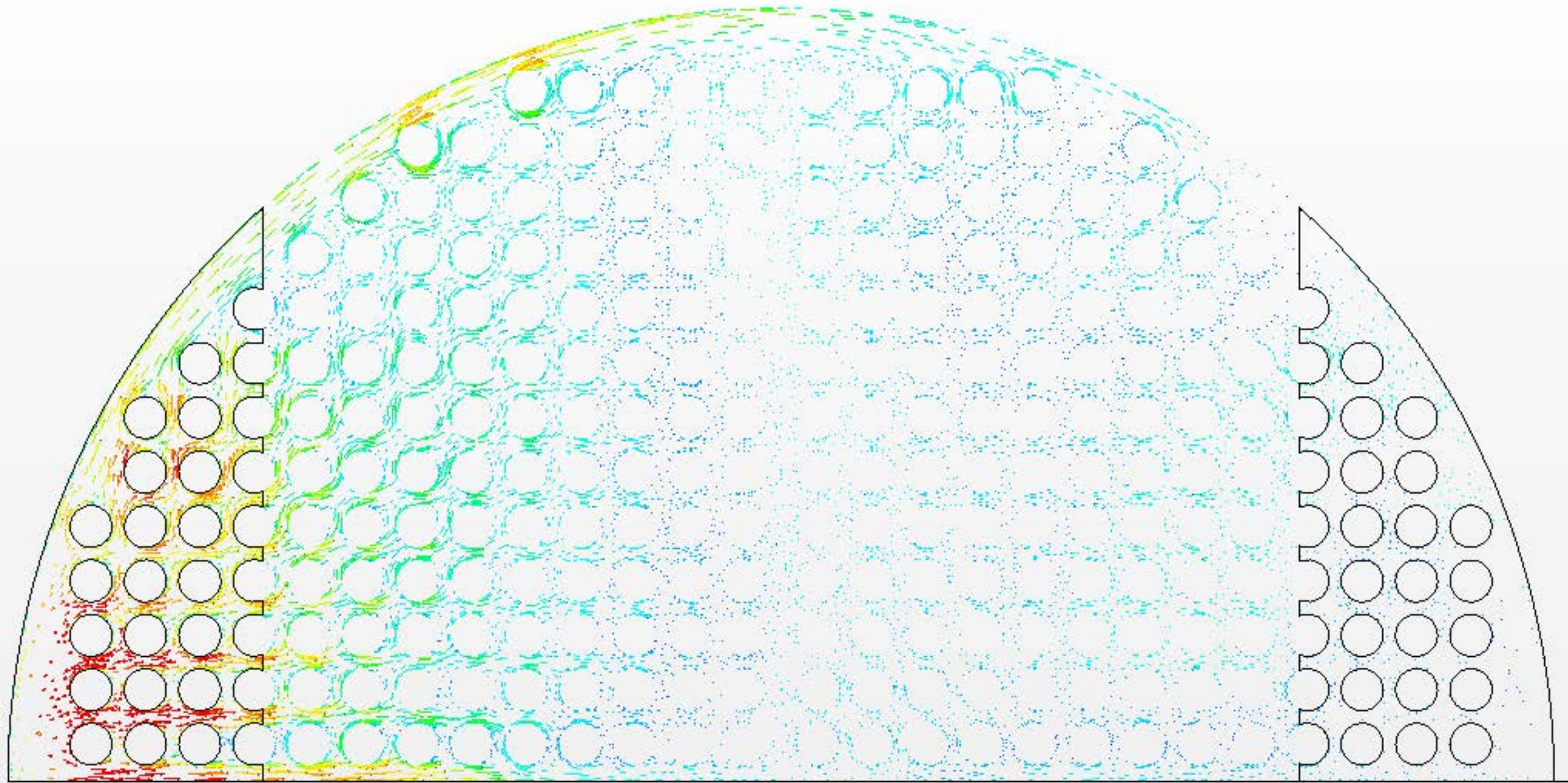

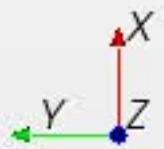
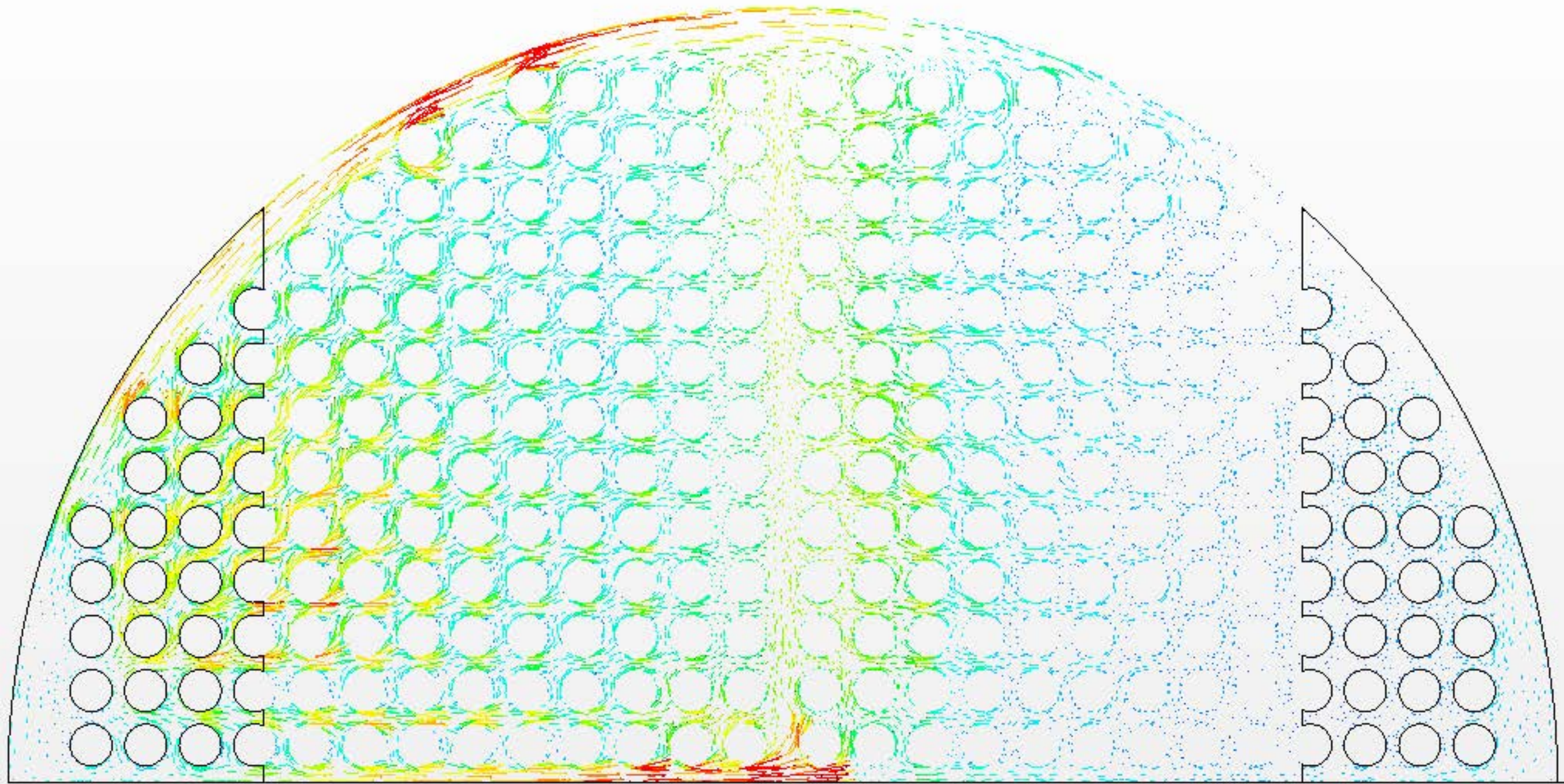

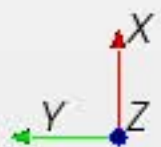
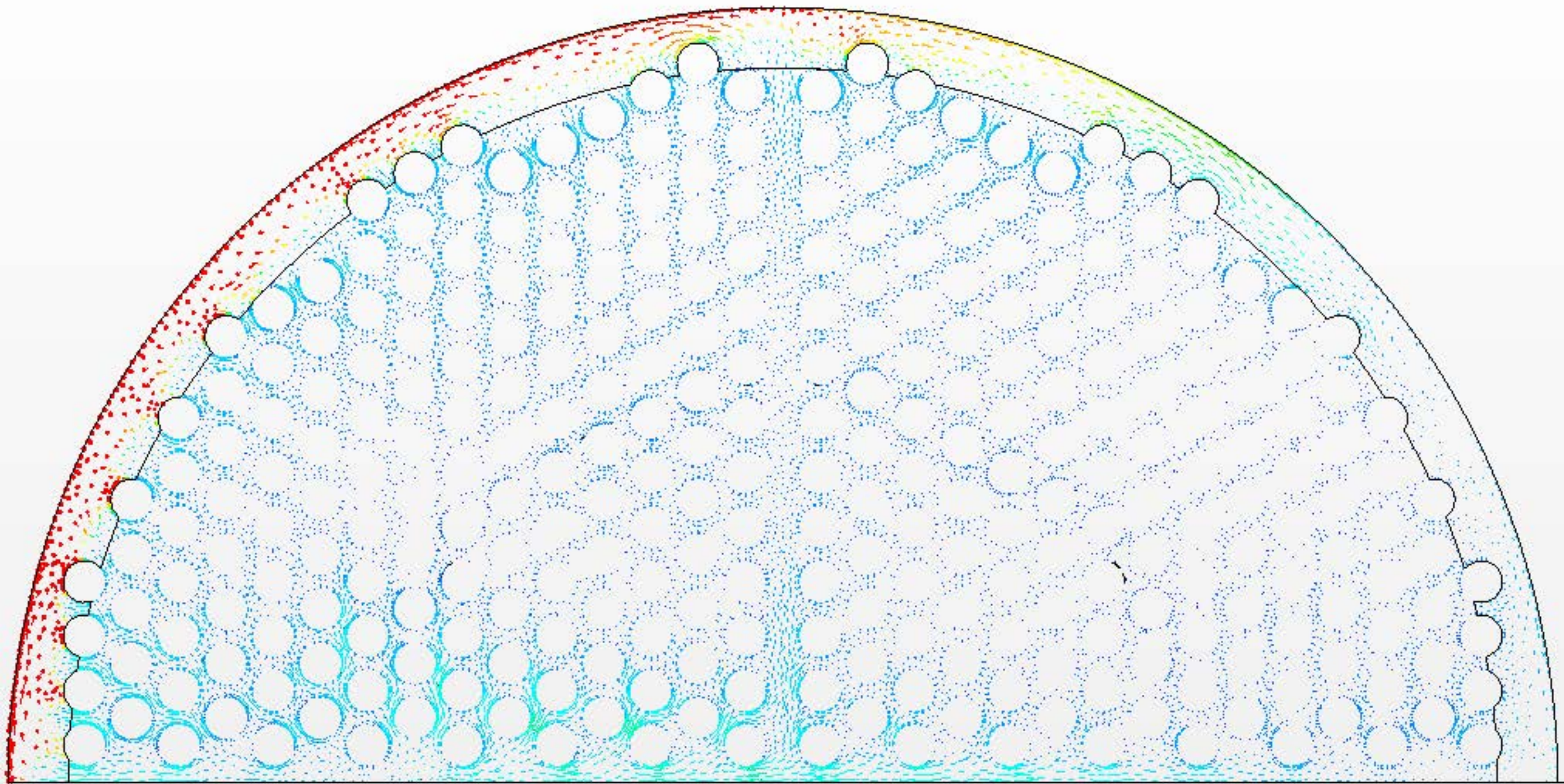

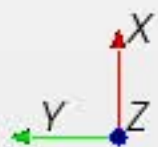
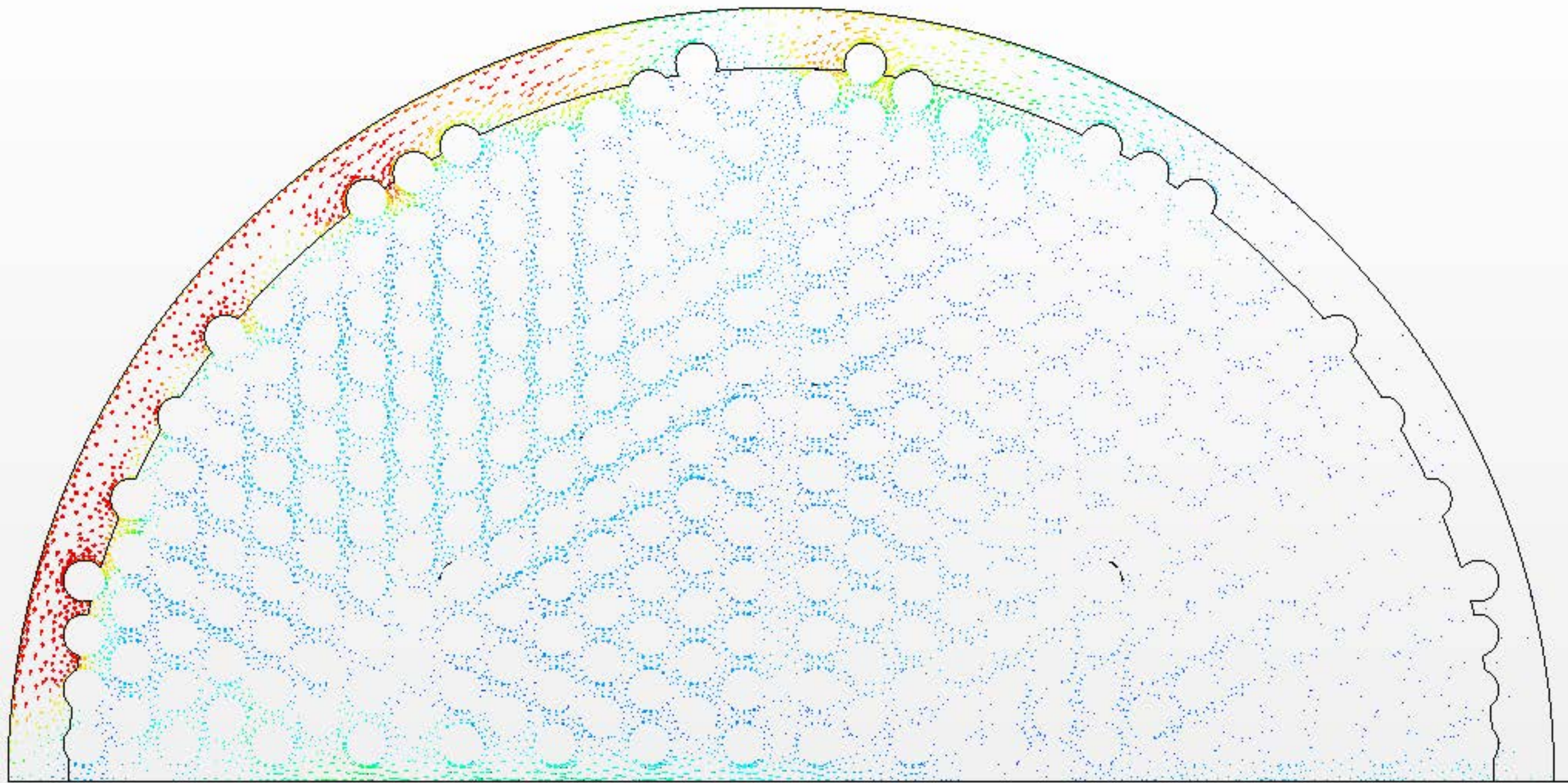

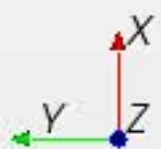
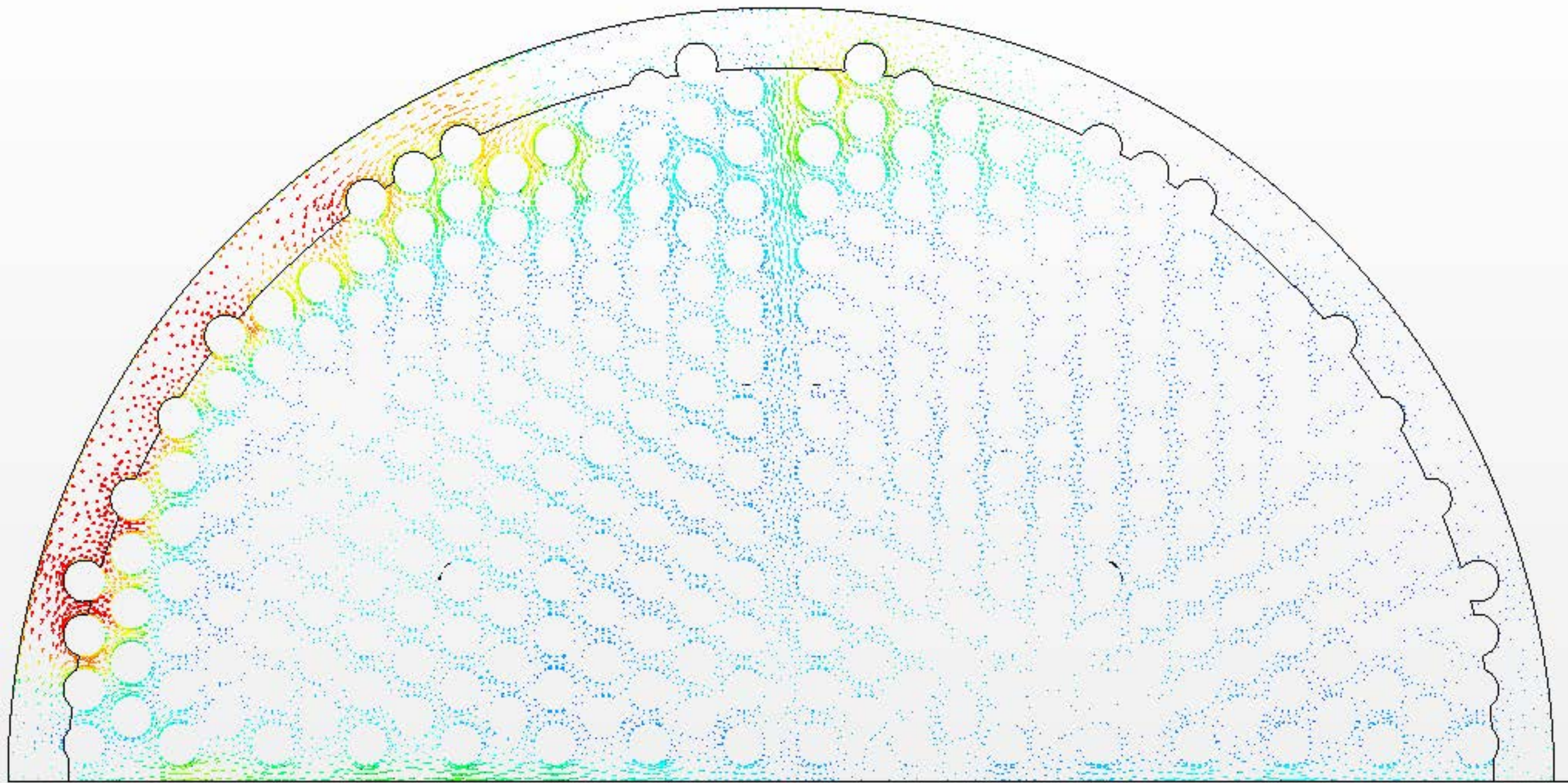

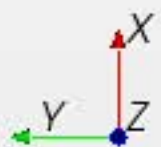
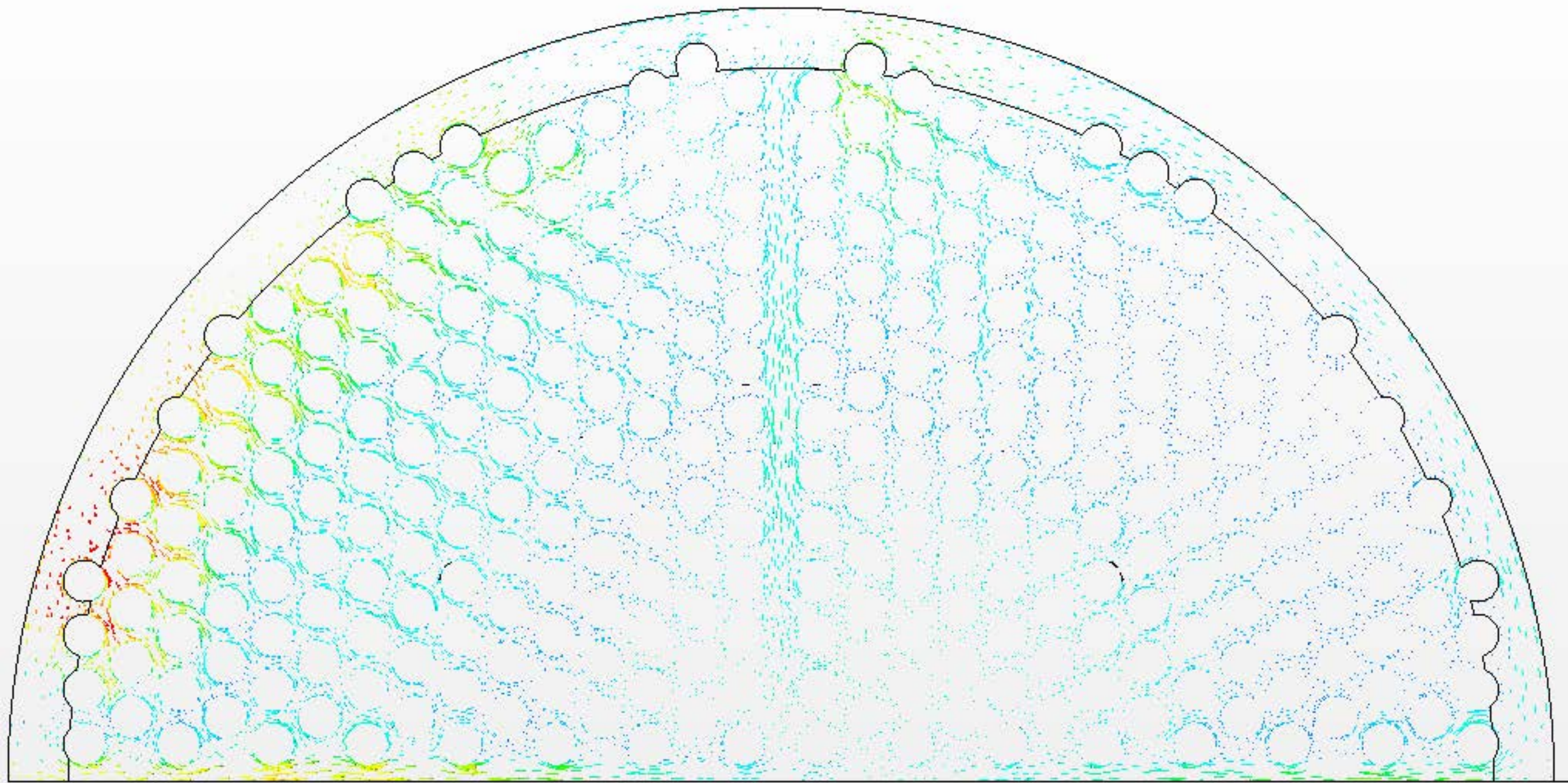

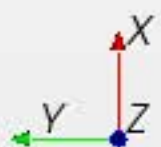
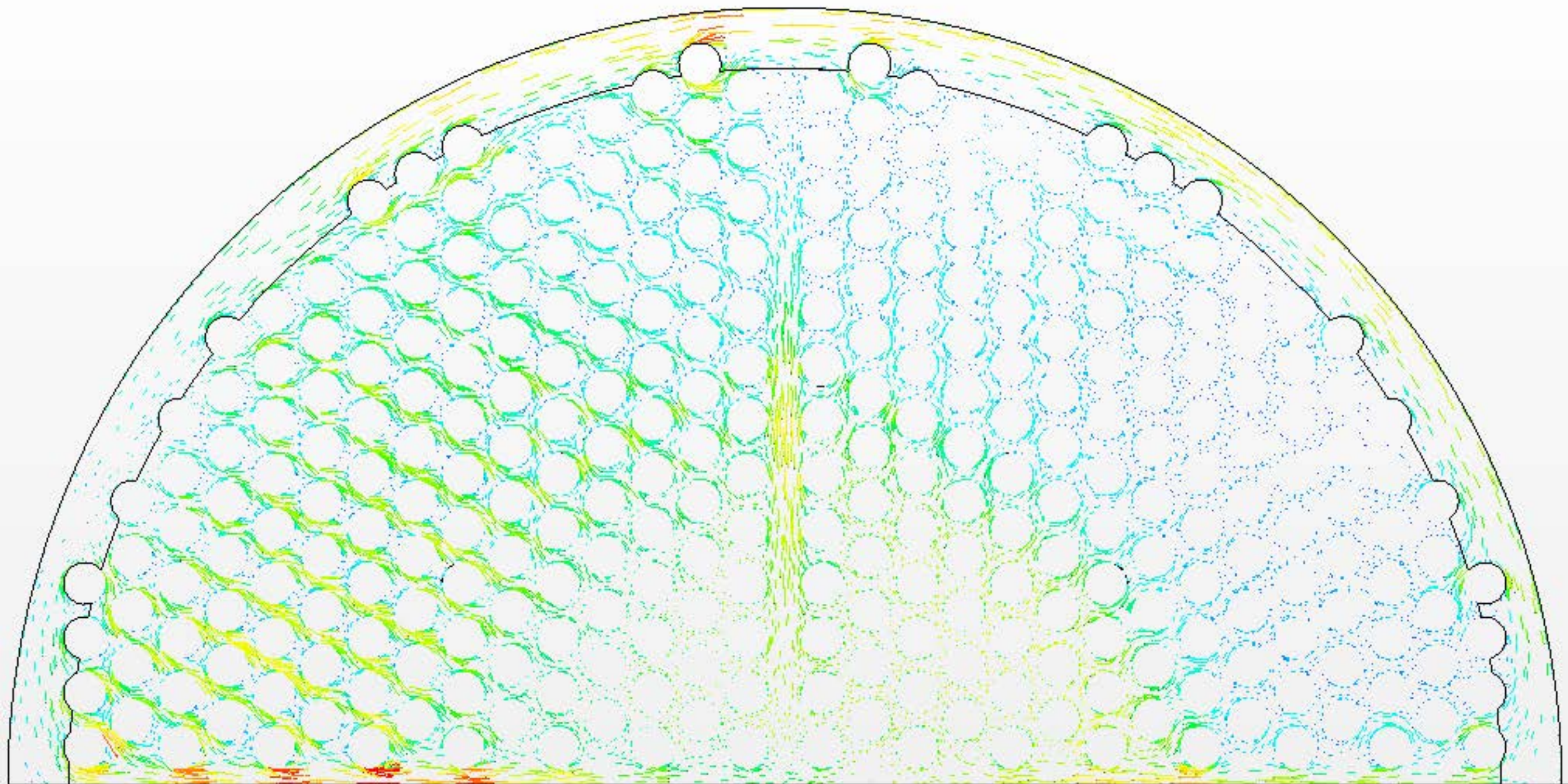

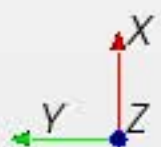
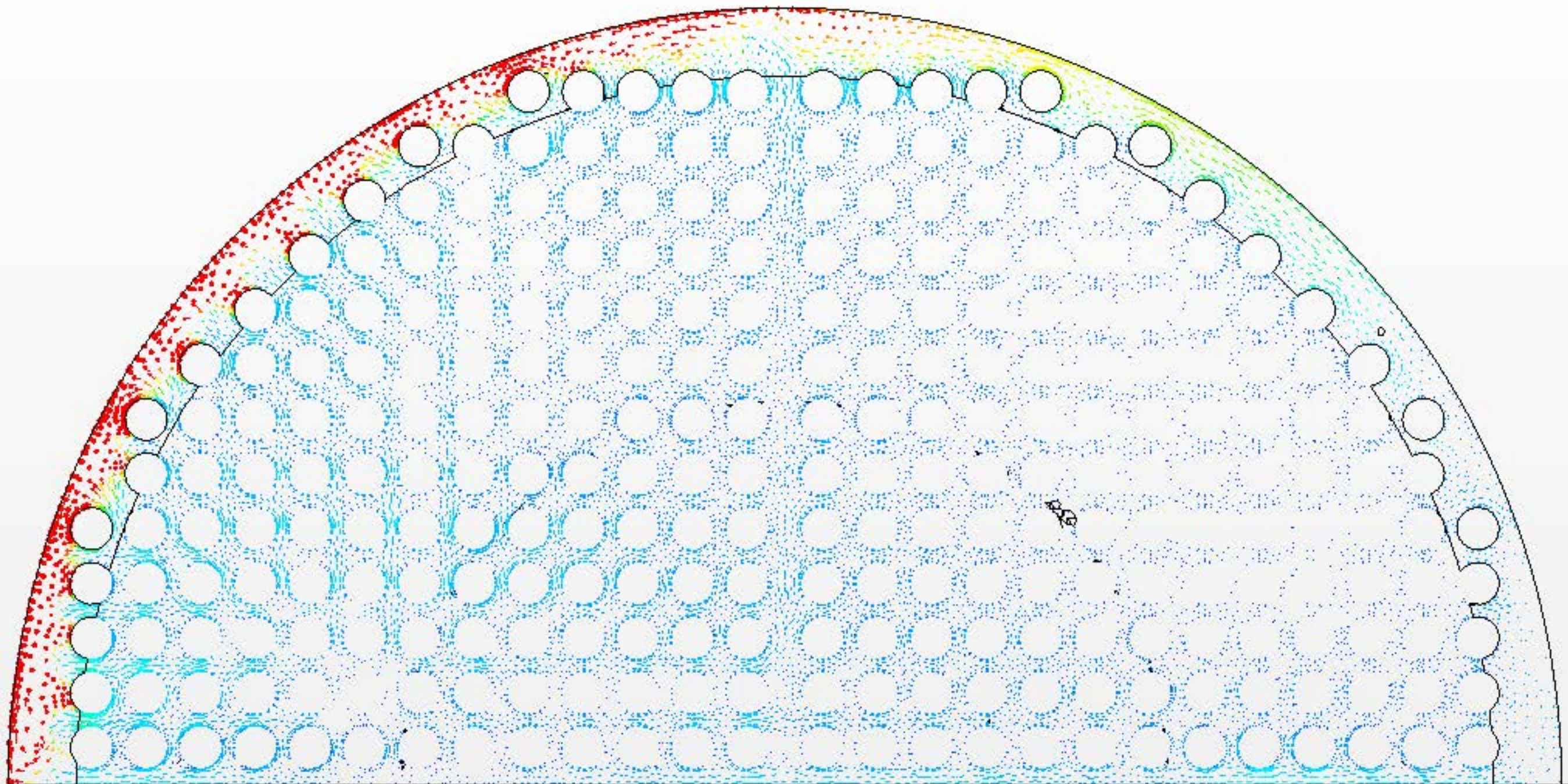

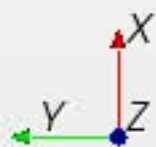
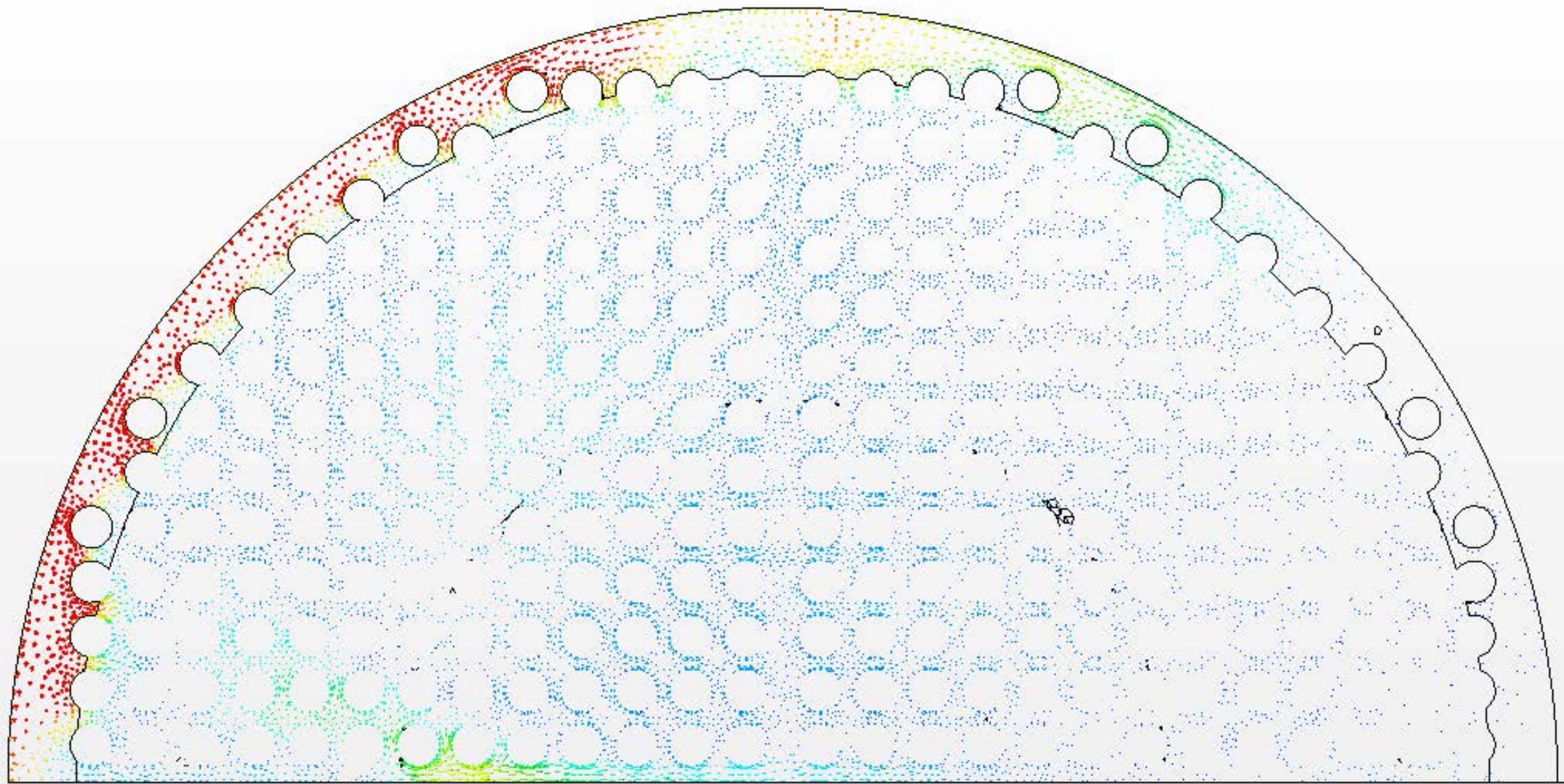

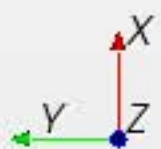
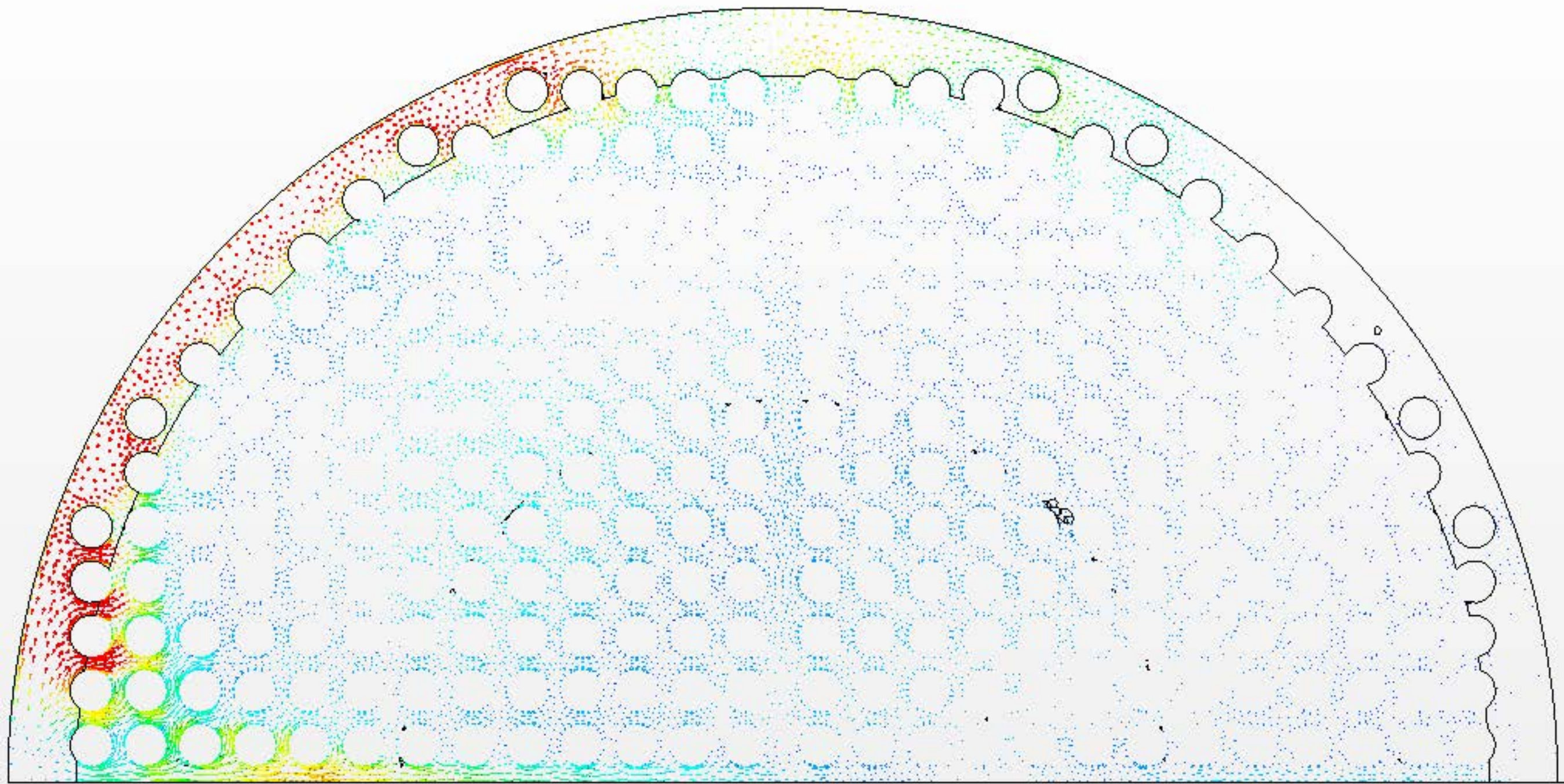

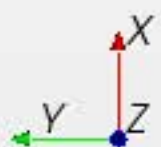
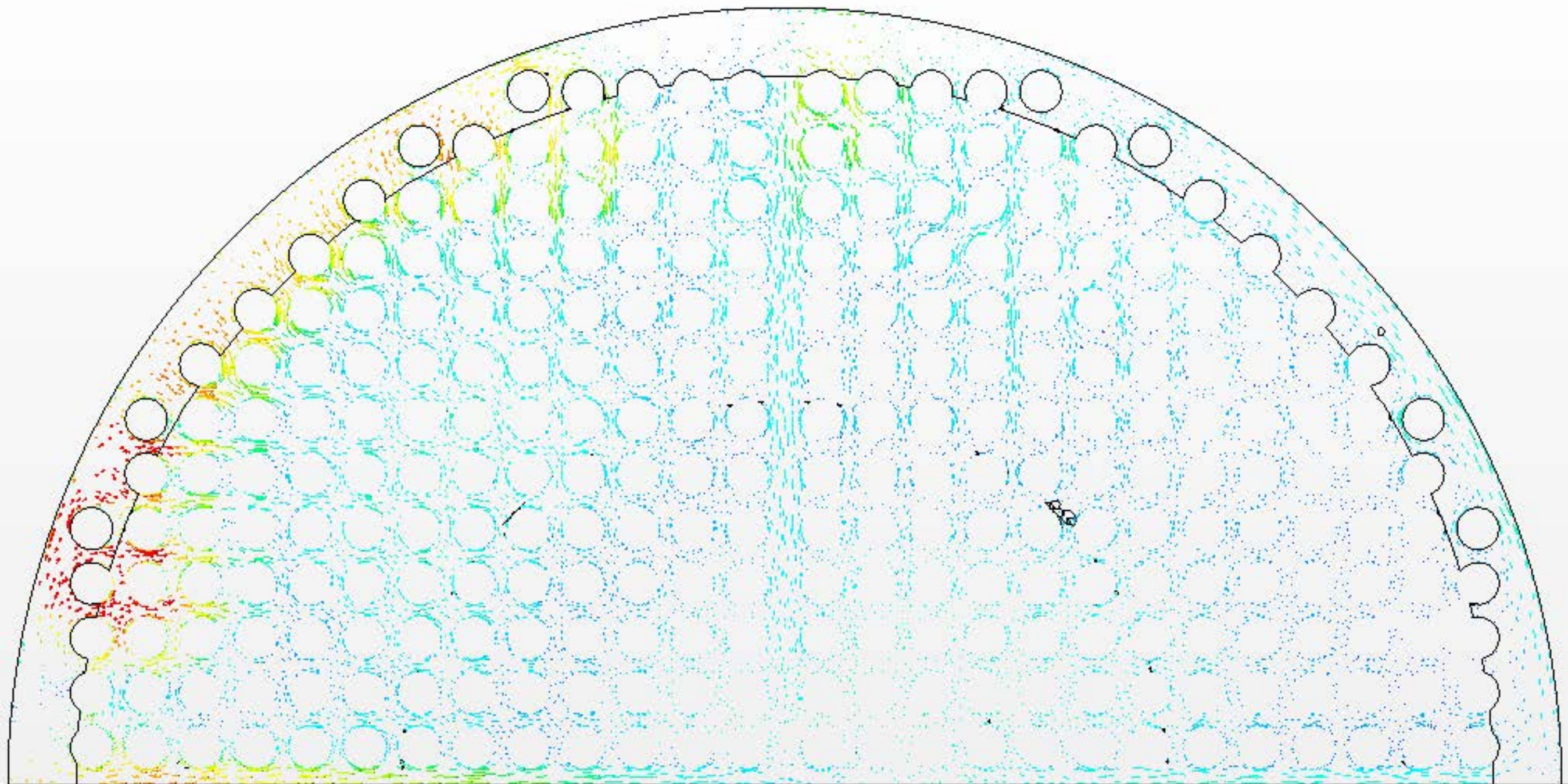

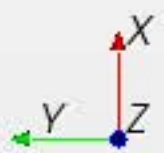
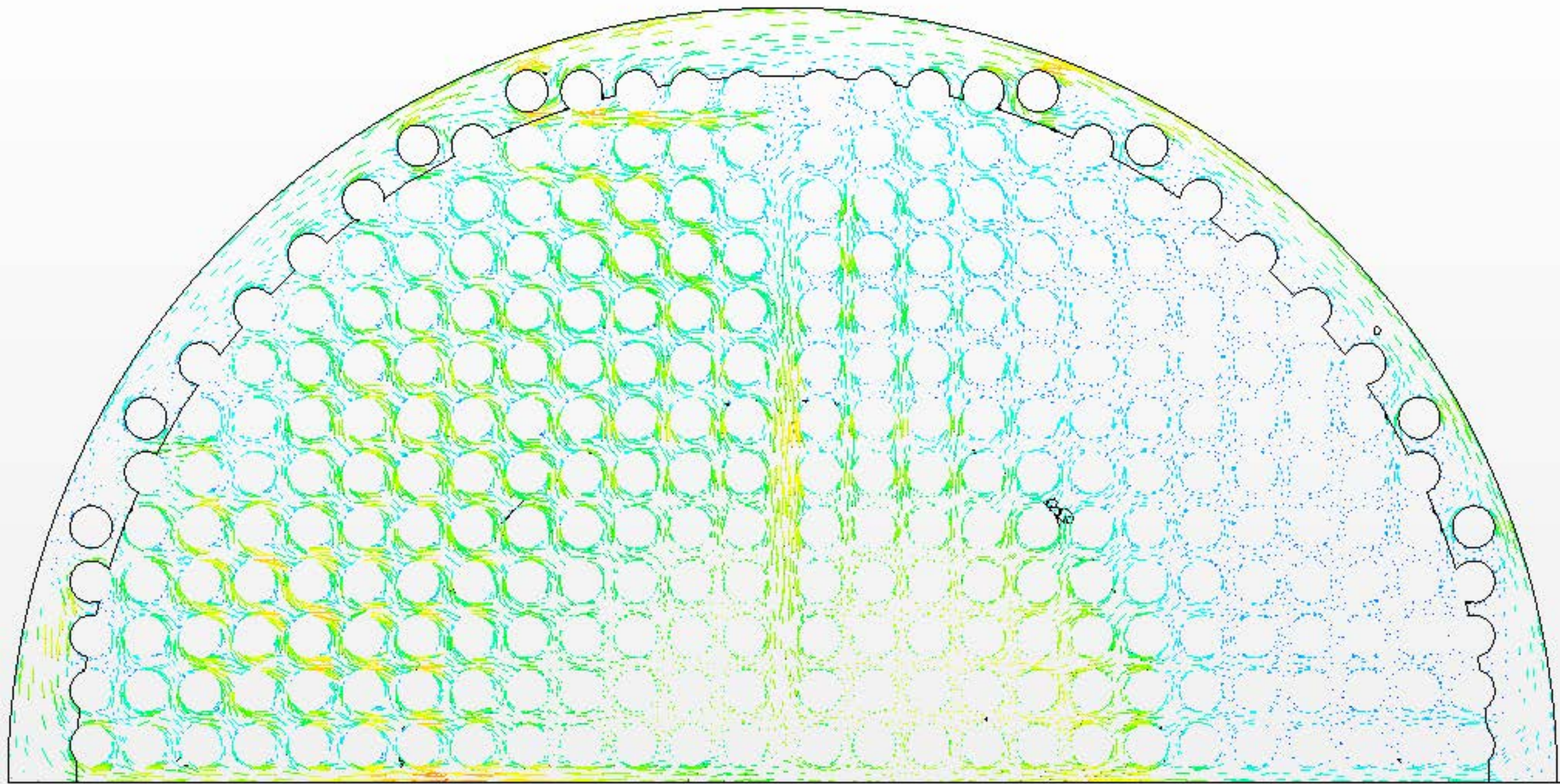

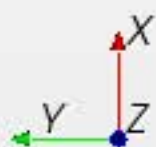
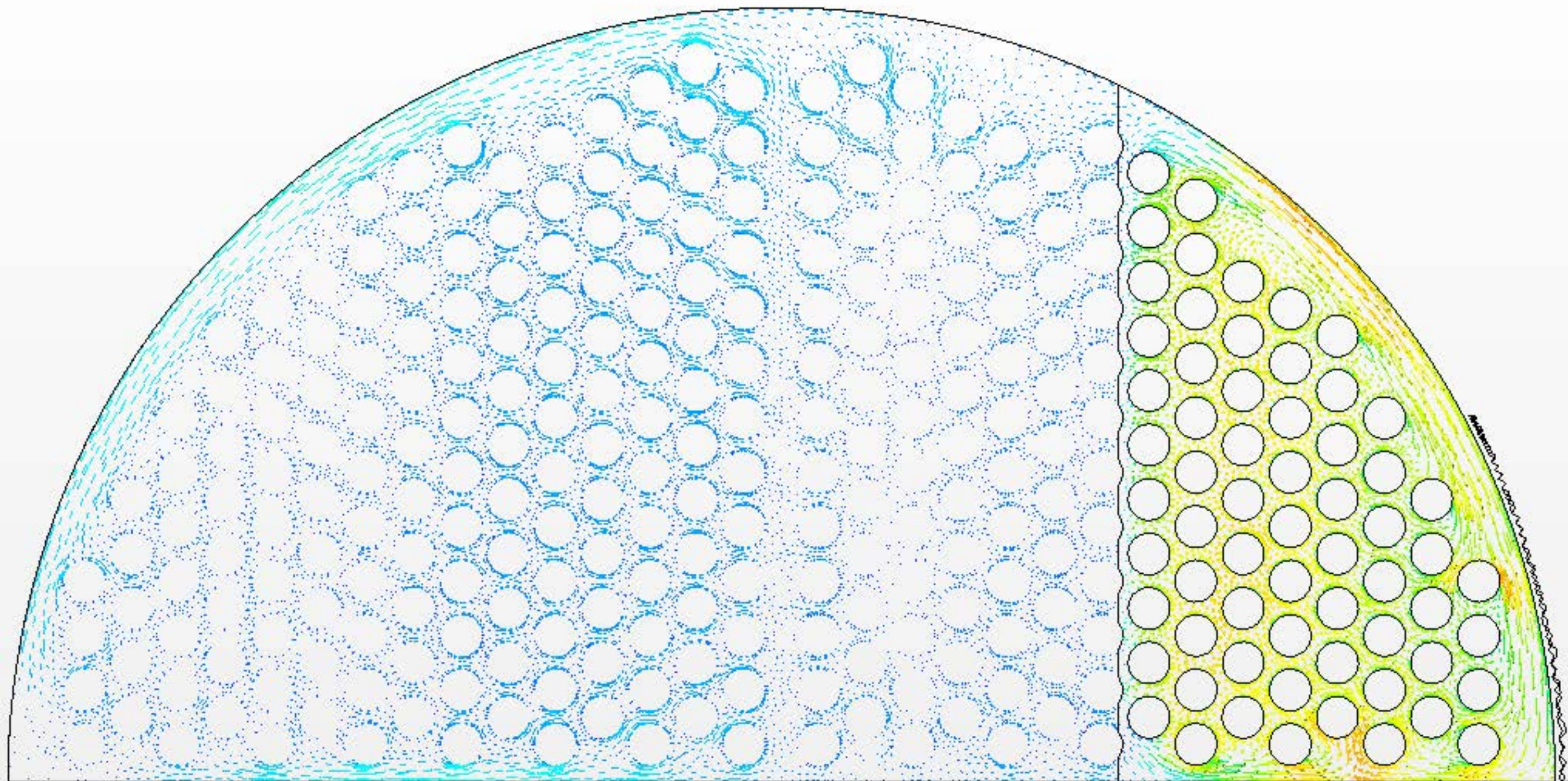

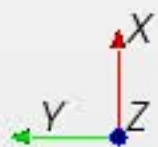
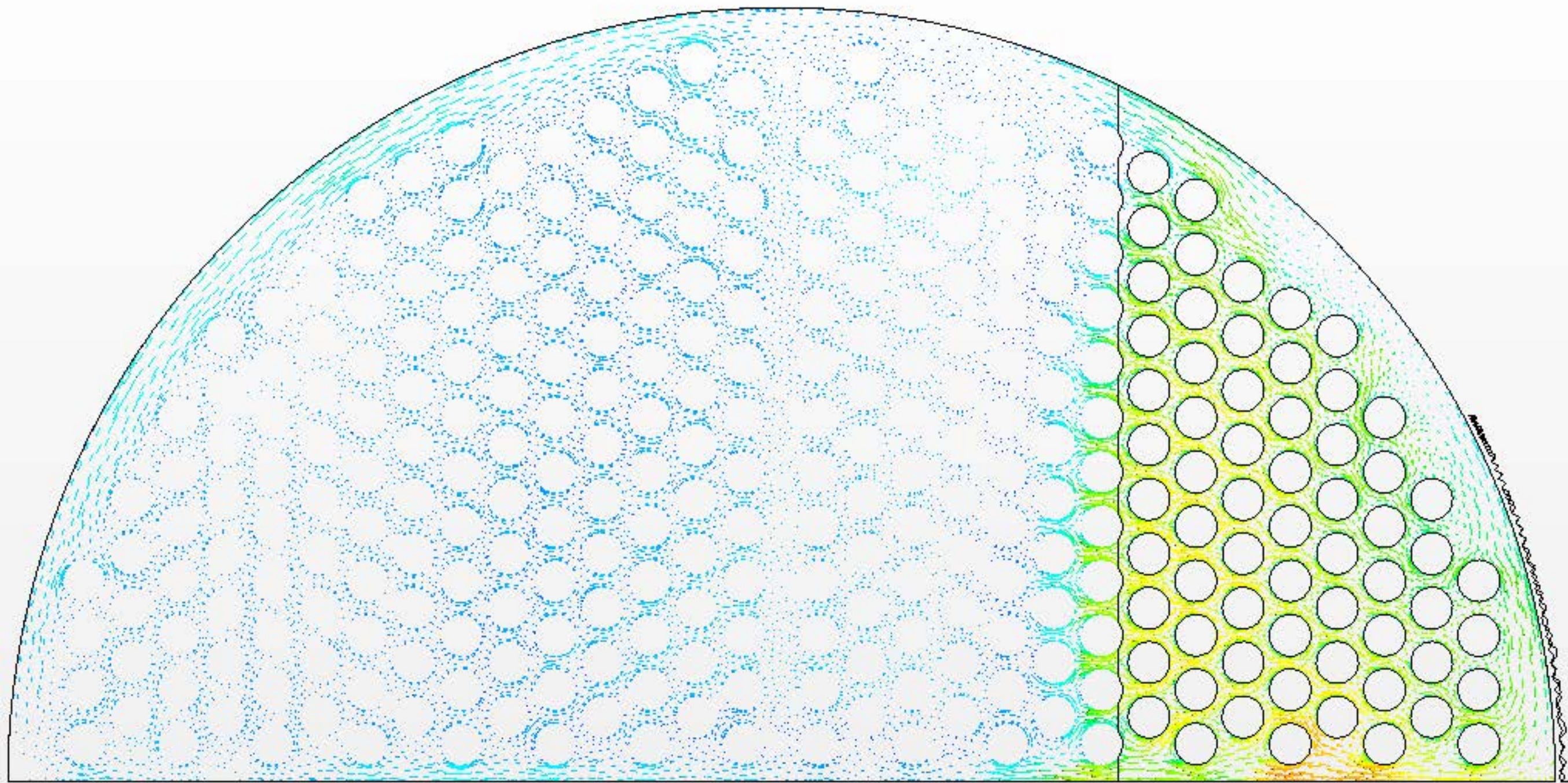

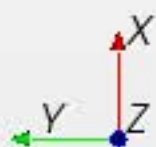
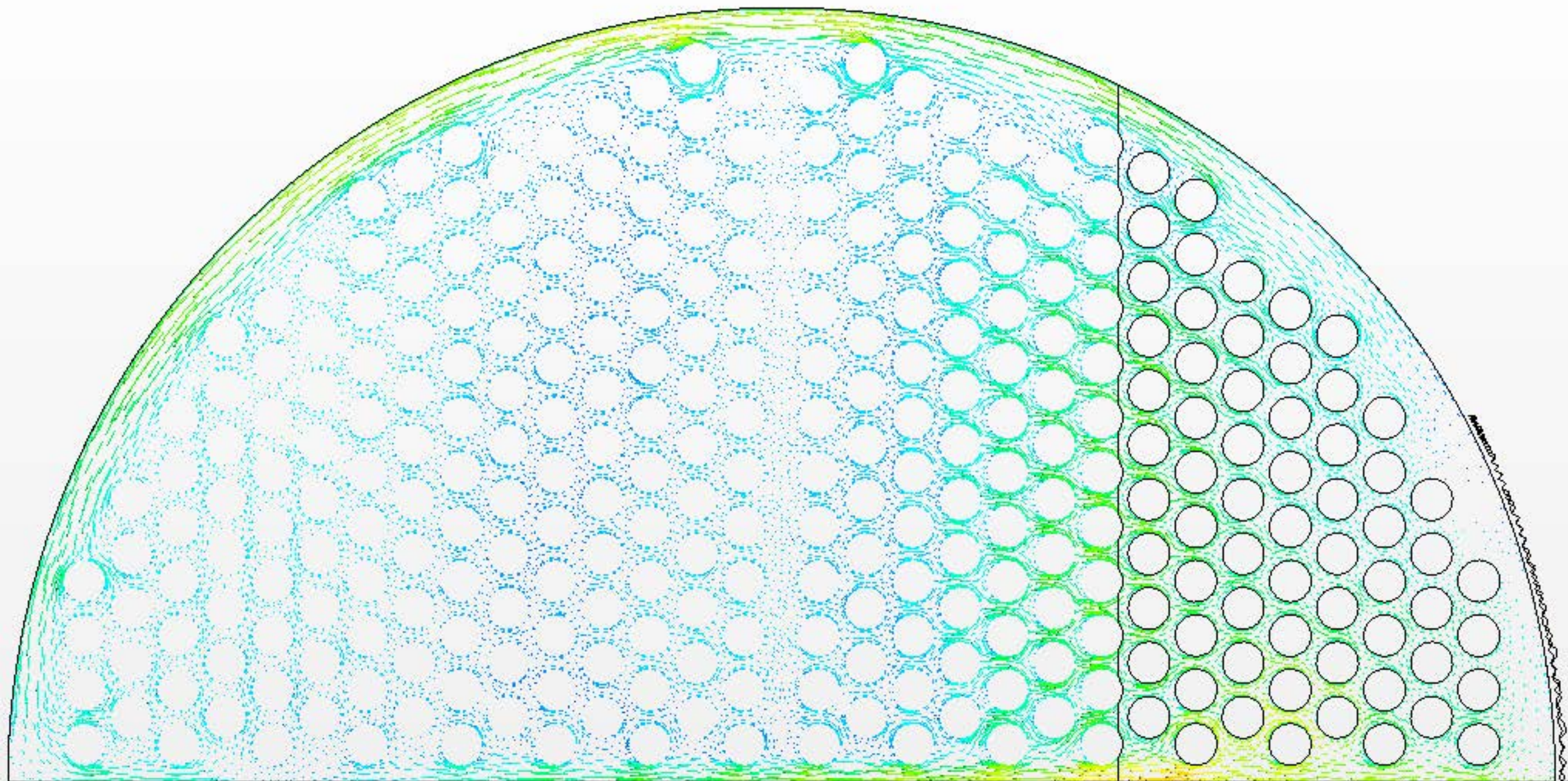

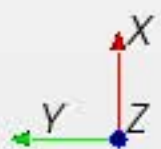
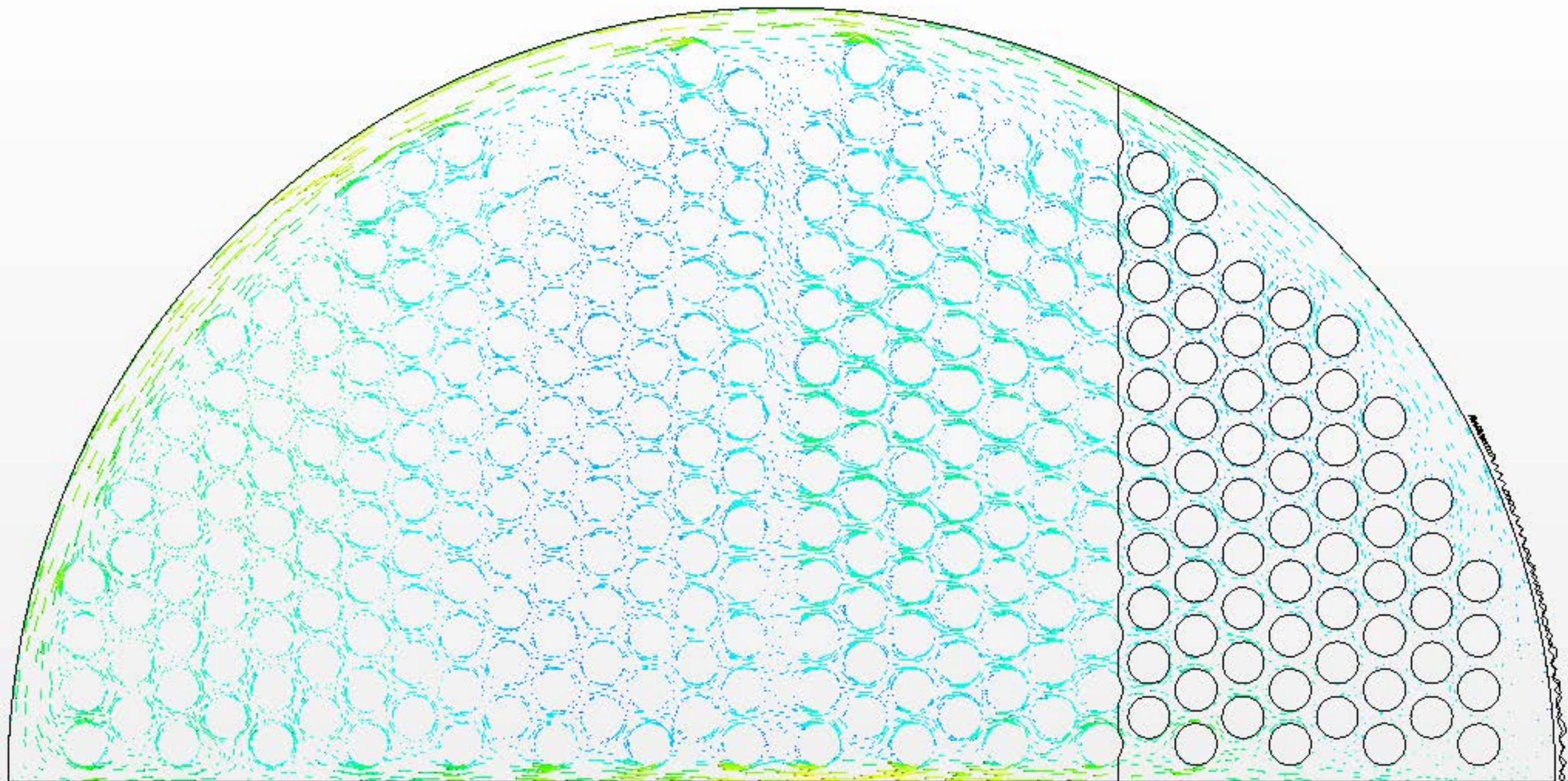

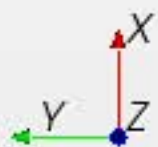
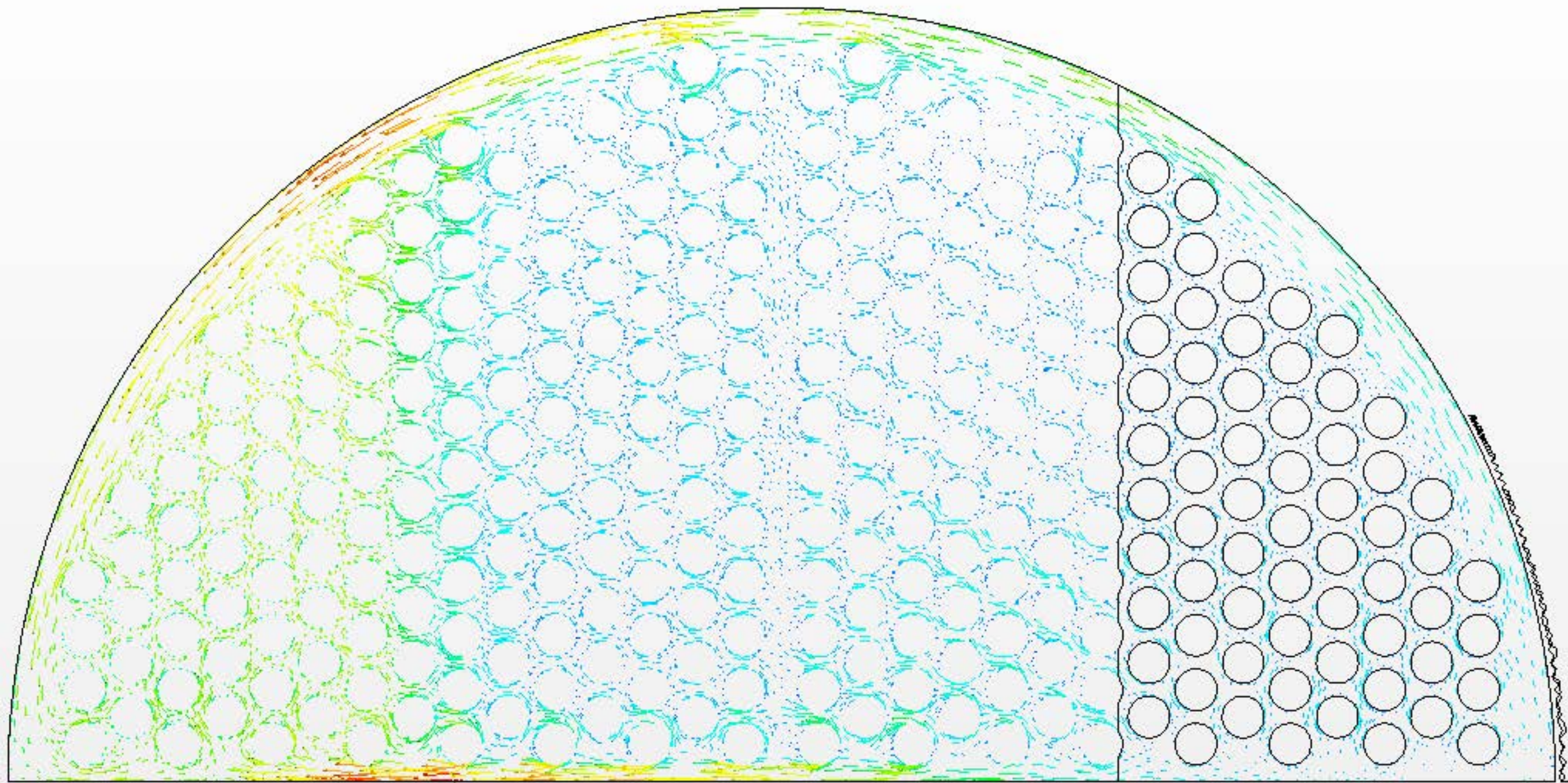

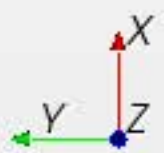
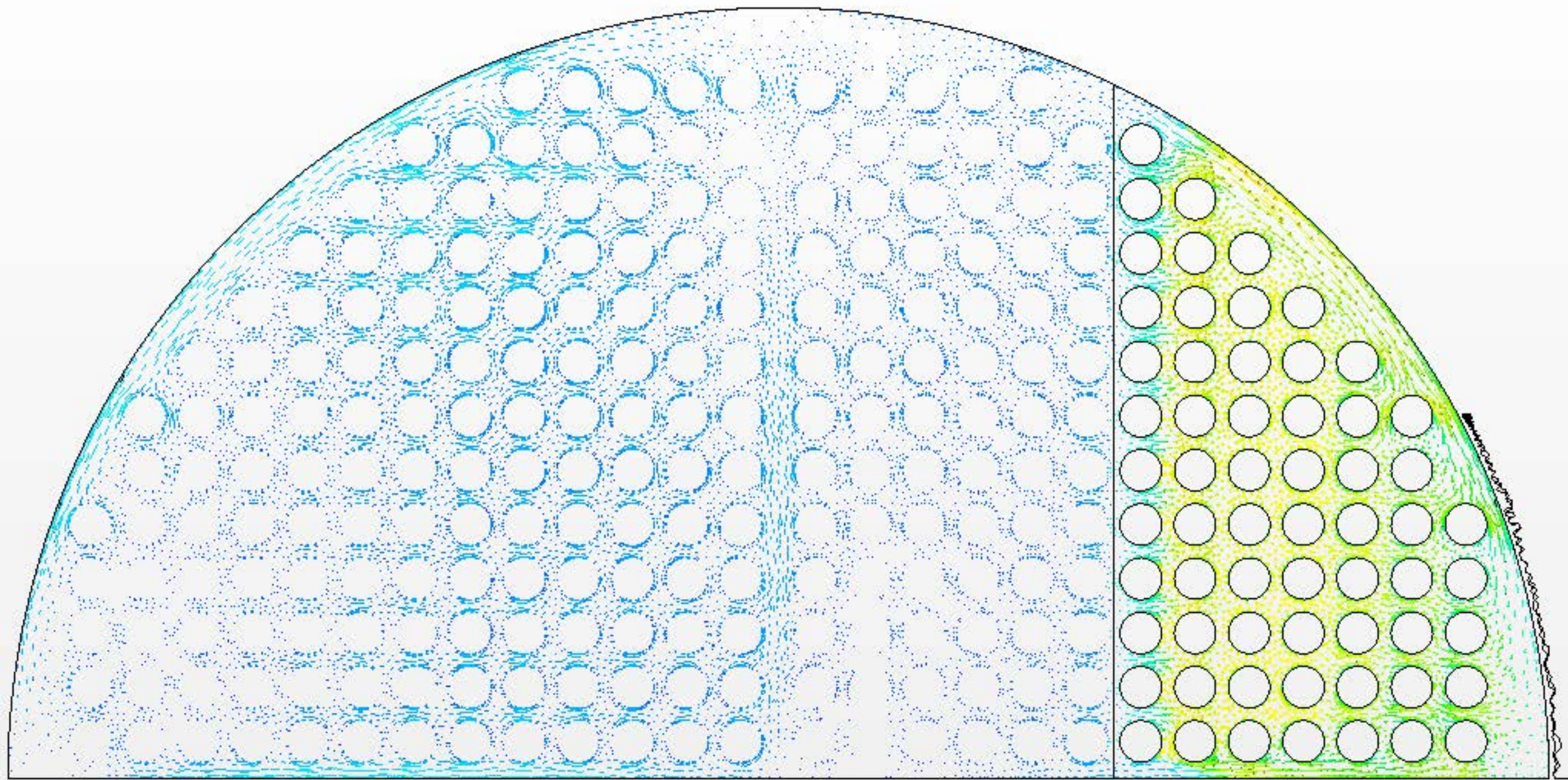

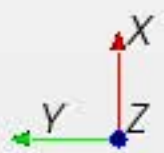
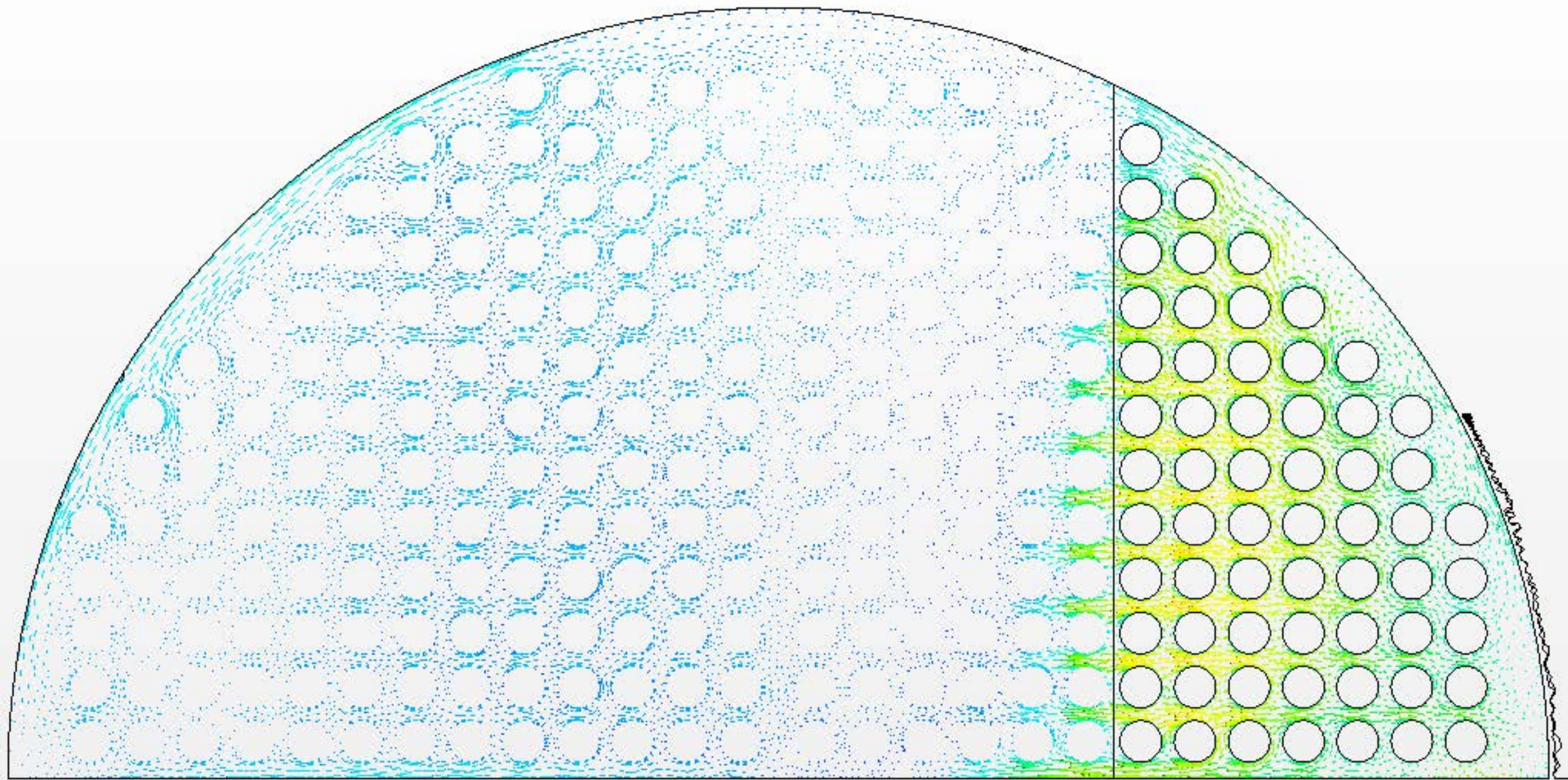

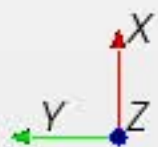
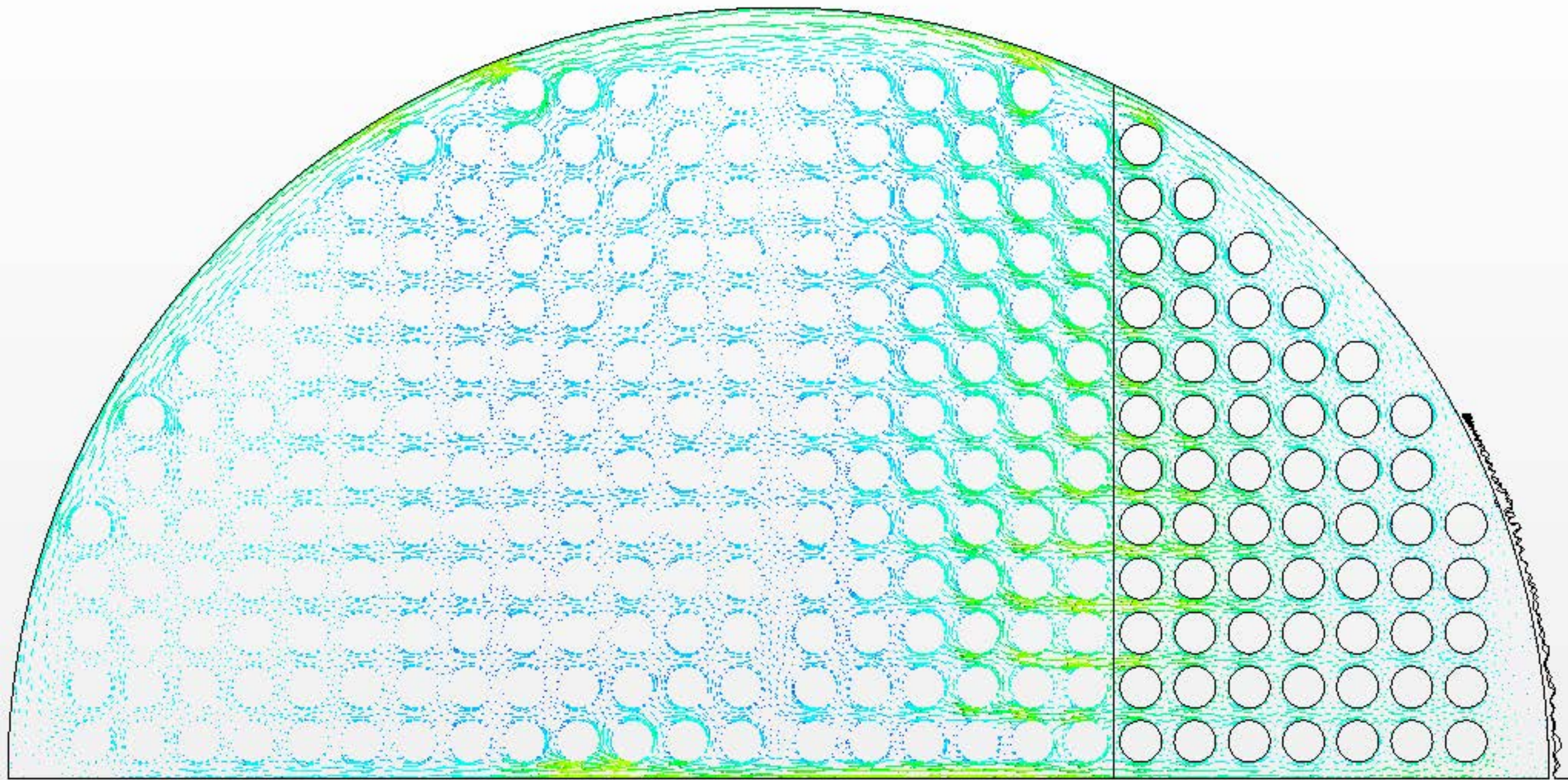

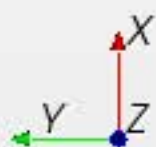
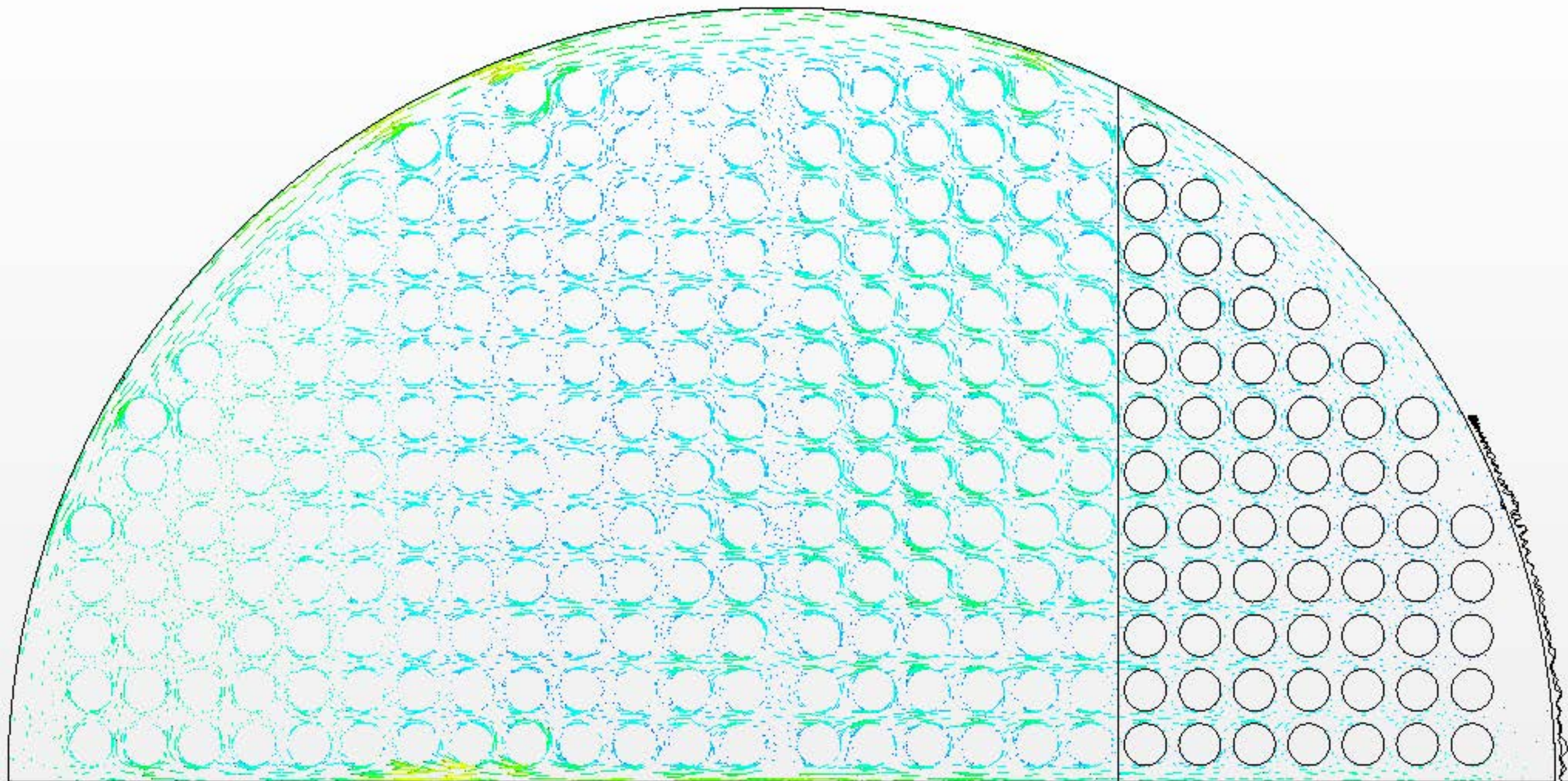

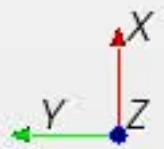
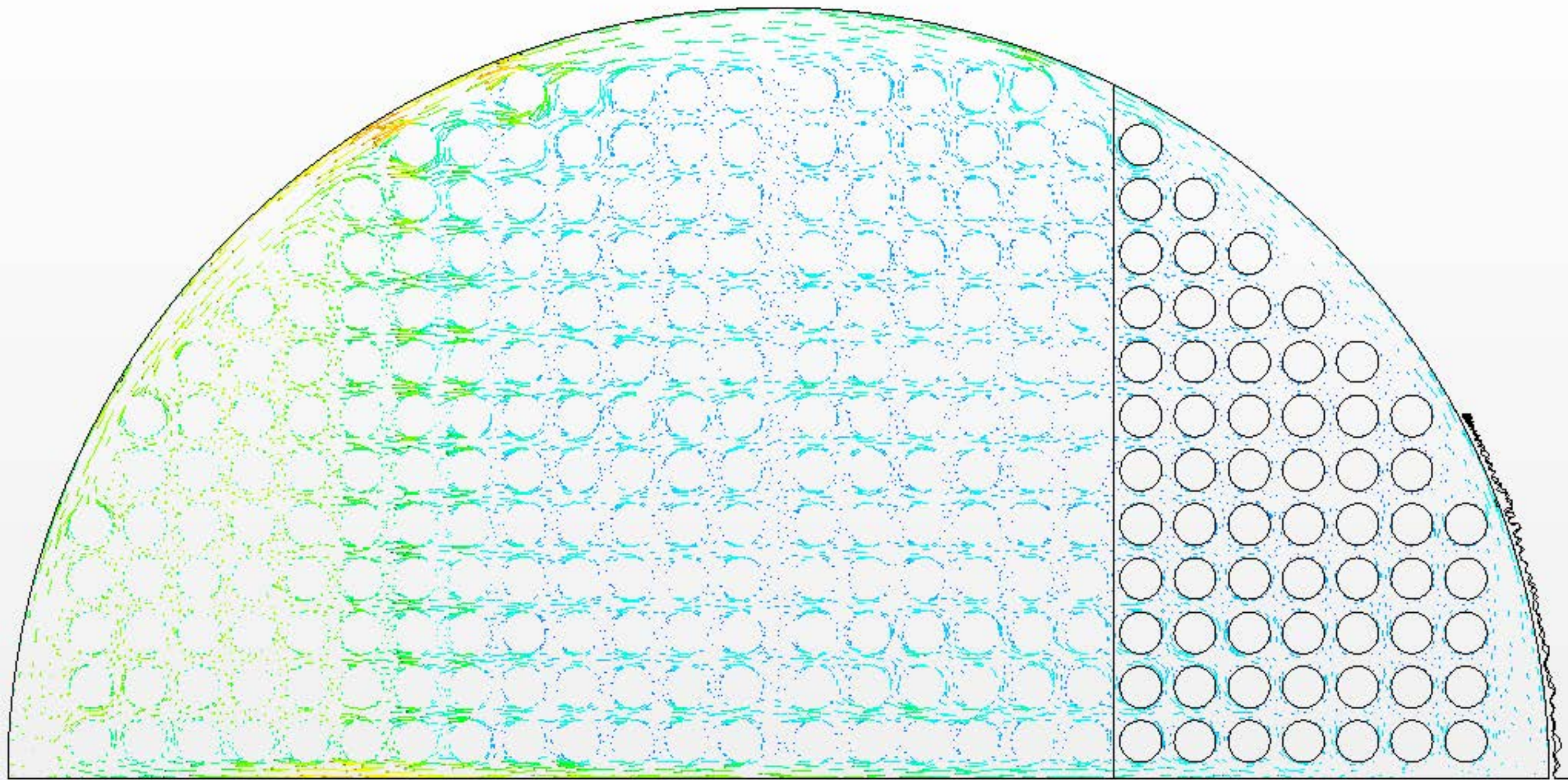

Velocity: Magnitude (m/s)



Appendix E

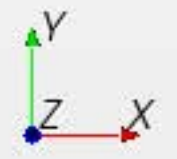
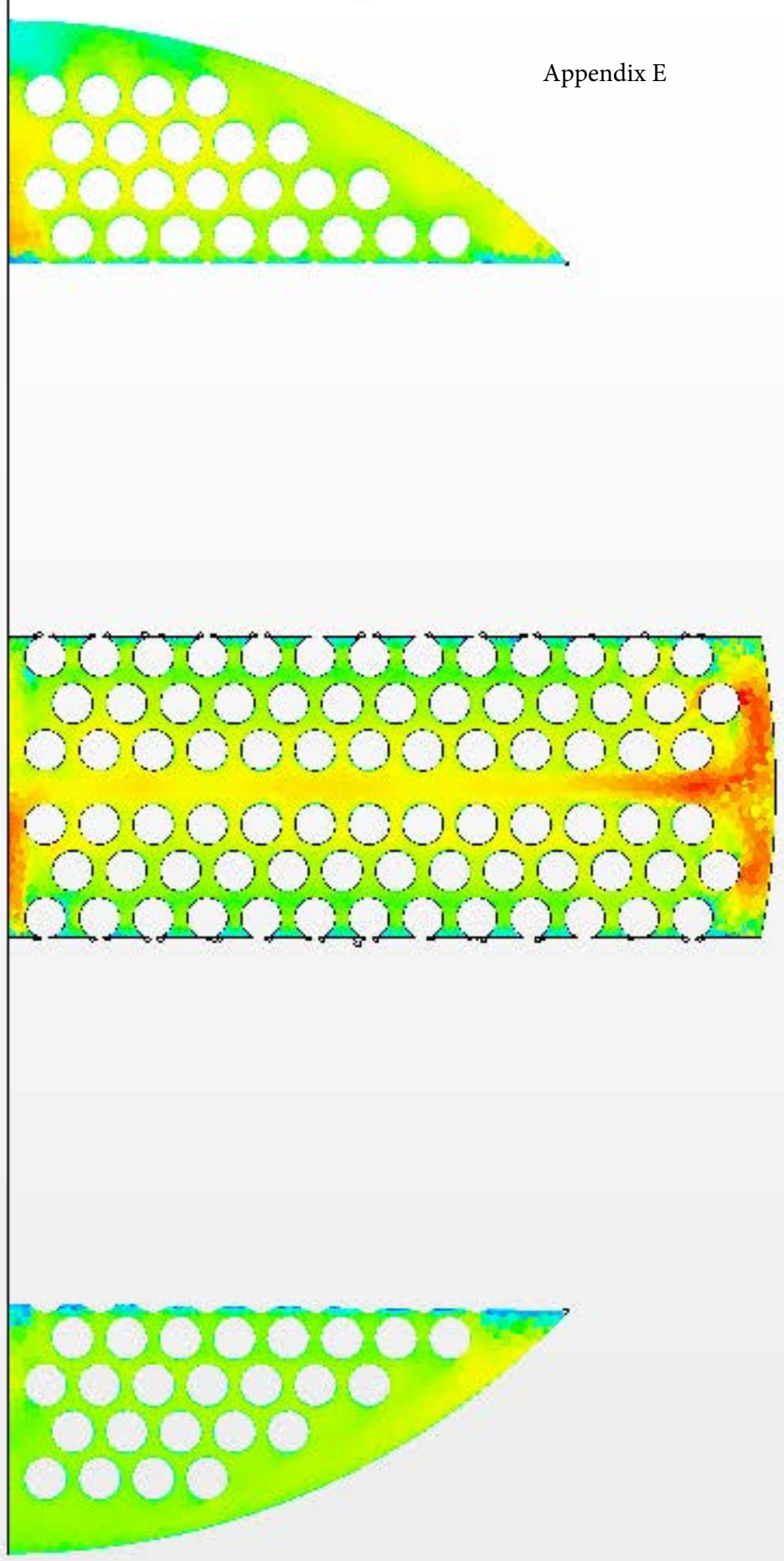

Velocity: Magnitude (m/s)

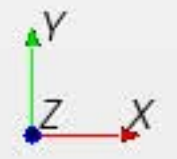
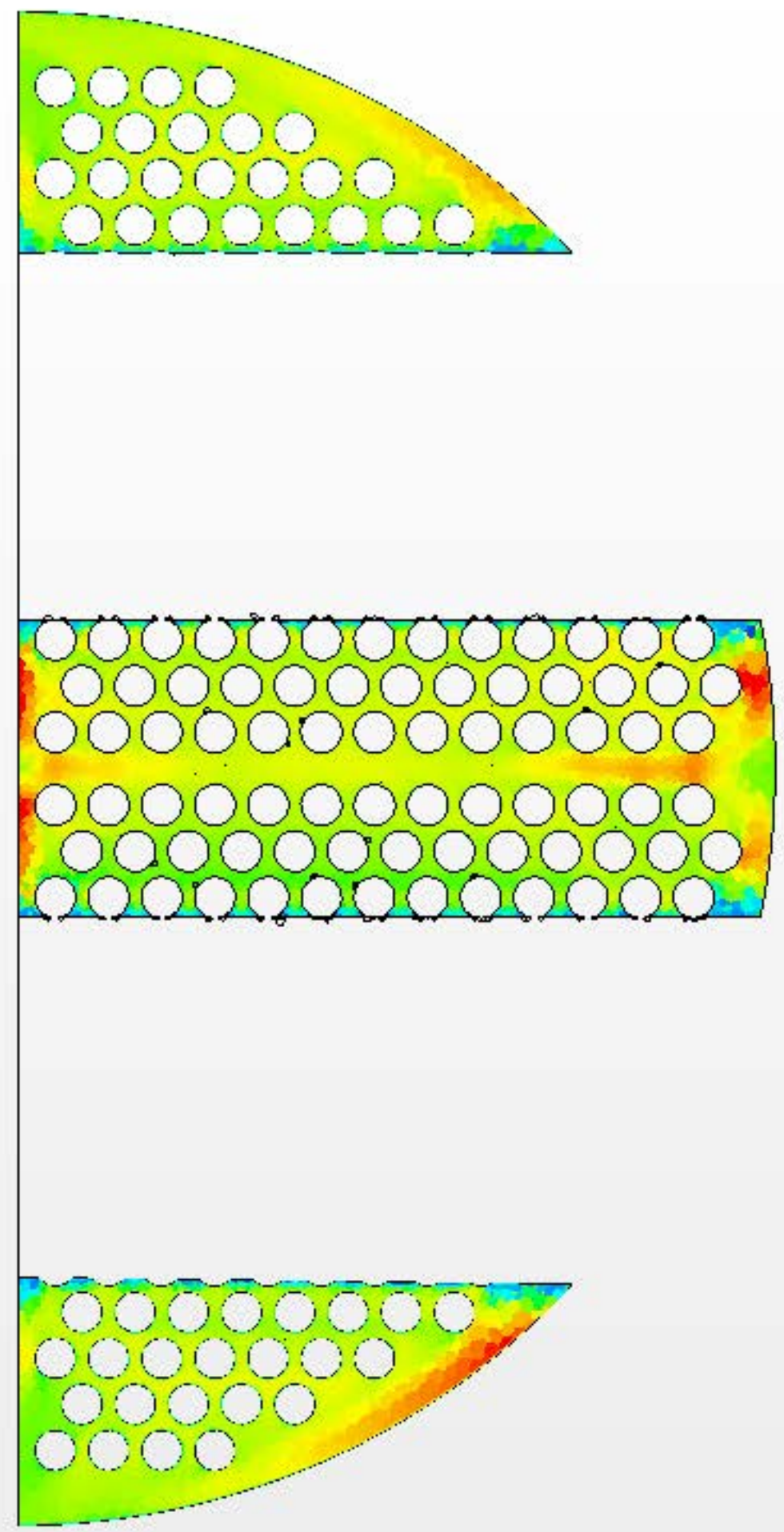

Velocity: Magnitude (m/s)

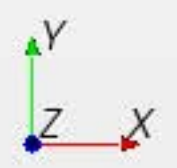
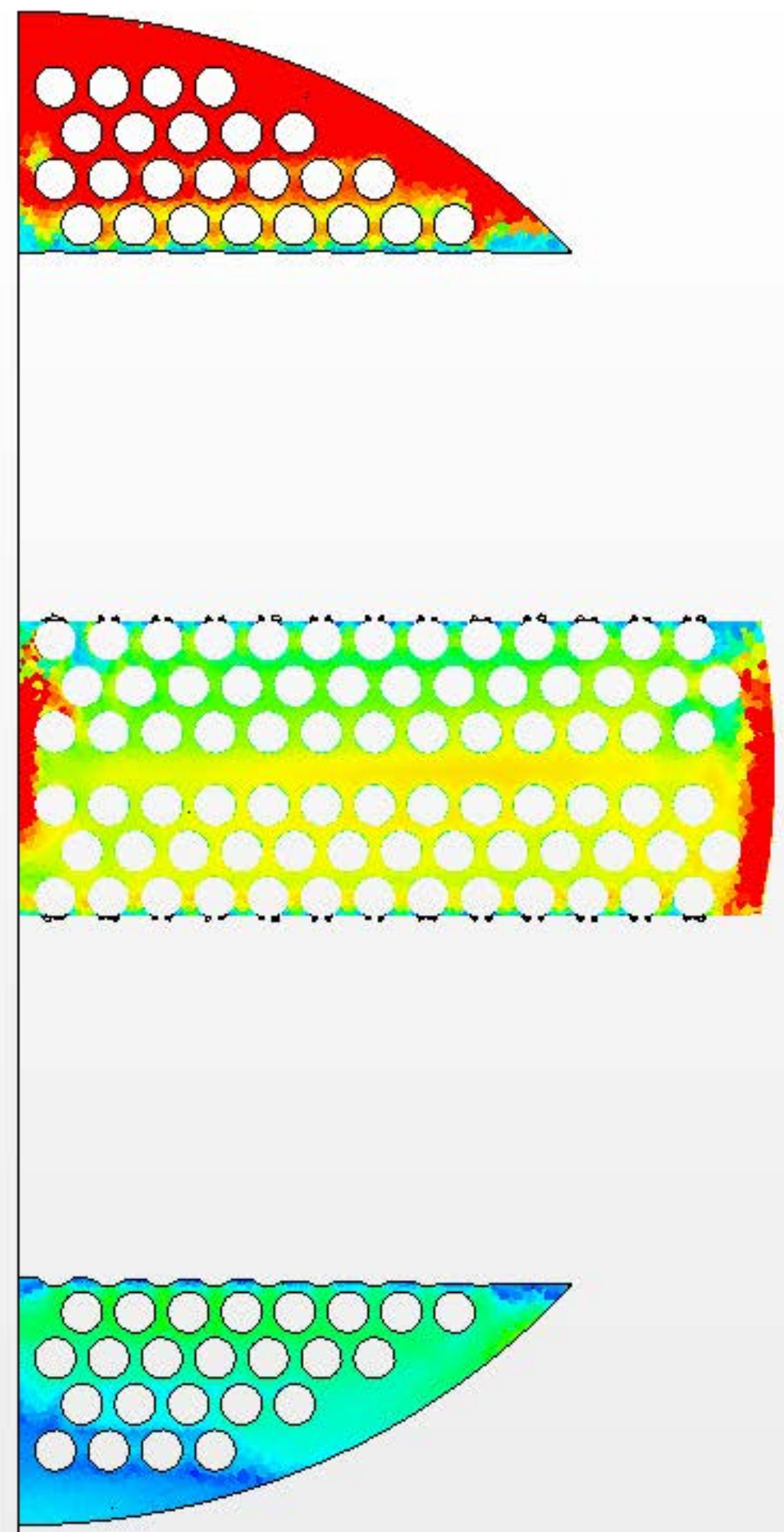

Velocity: Magnitude (m/s)

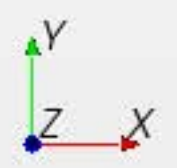
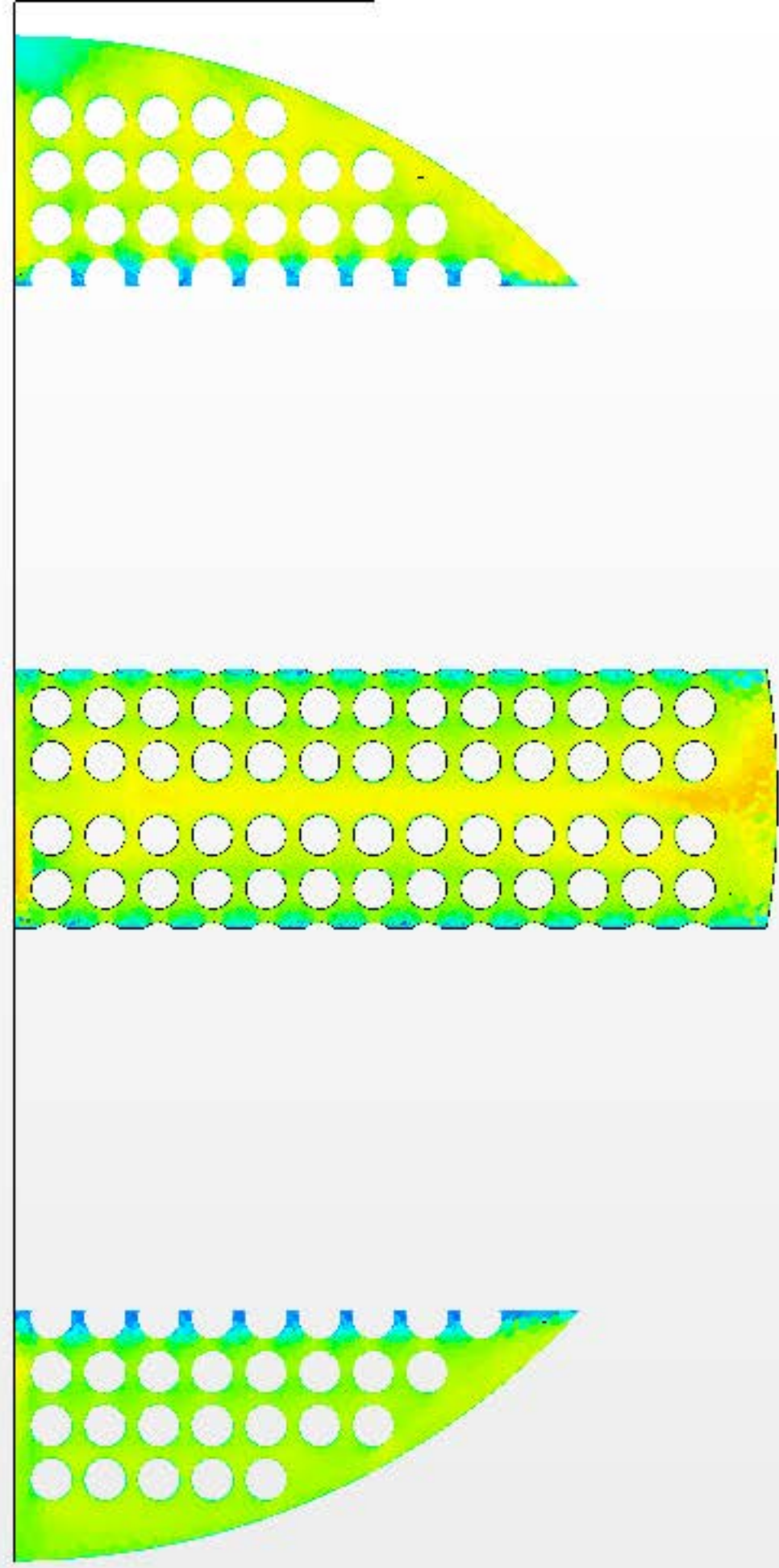

Velocity: Magnitude (m/s)

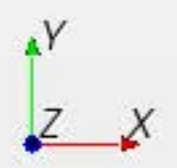
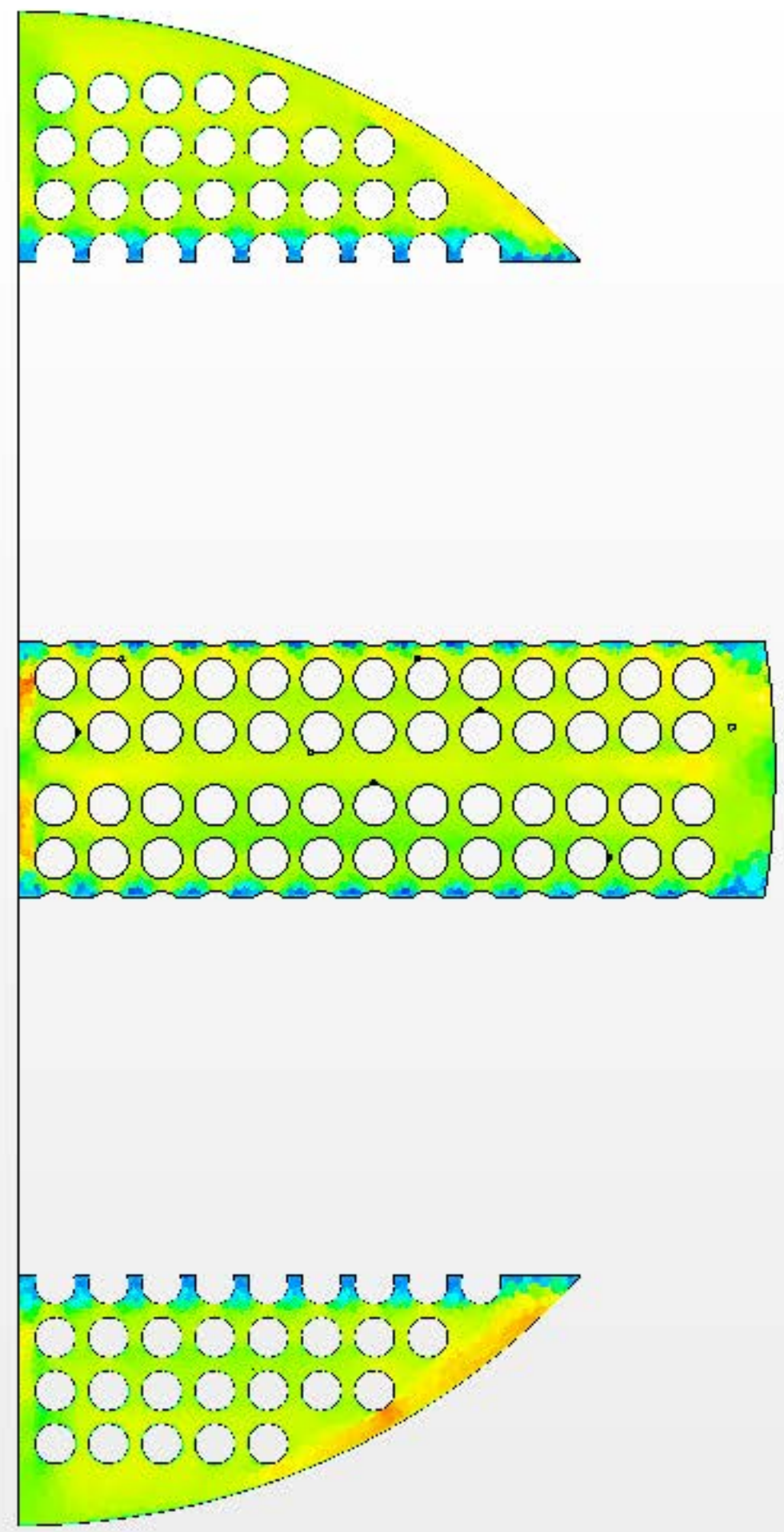

Velocity: Magnitude (m/s)

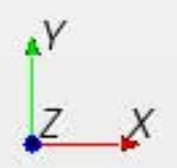
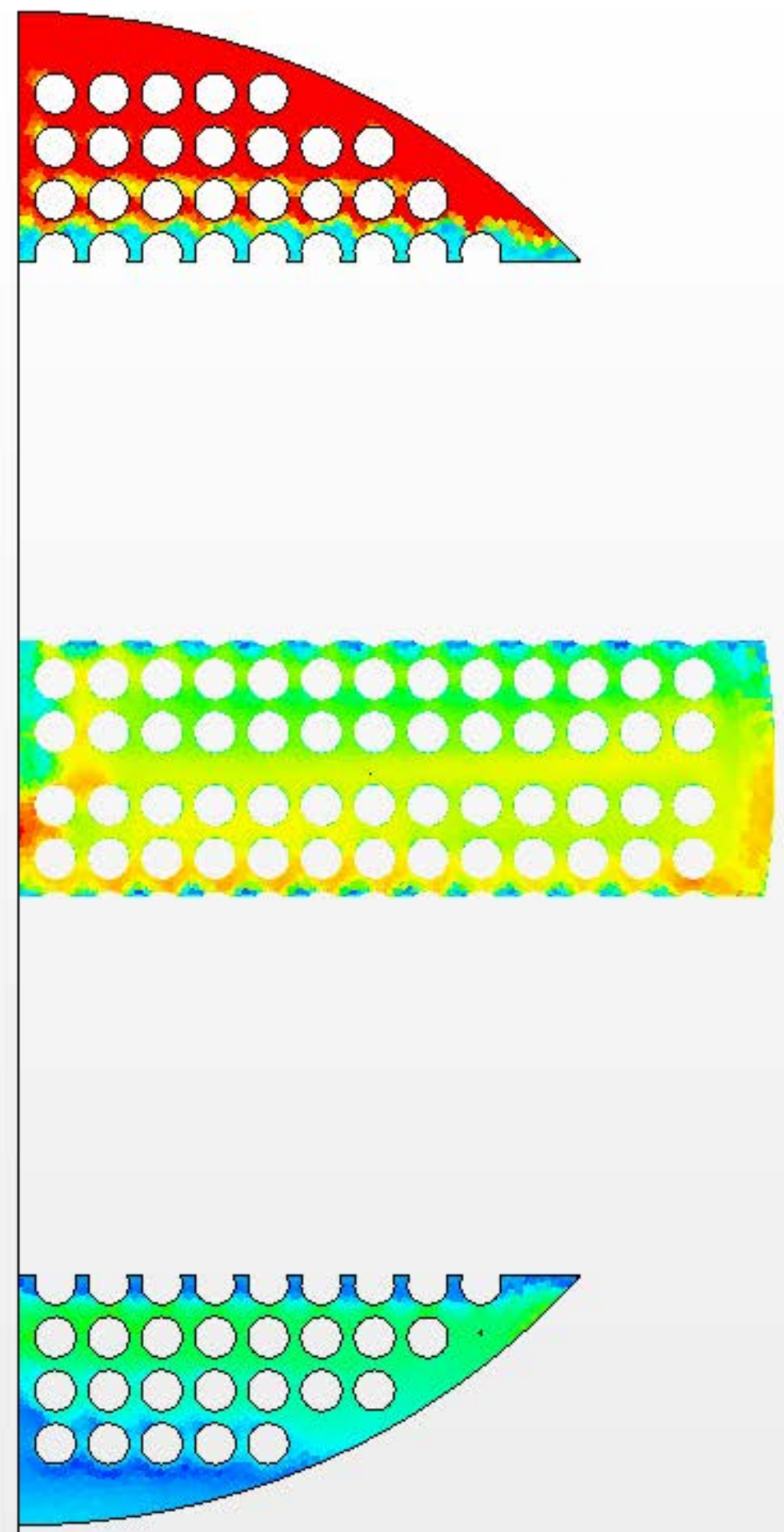

Velocity: Magnitude (m/s)

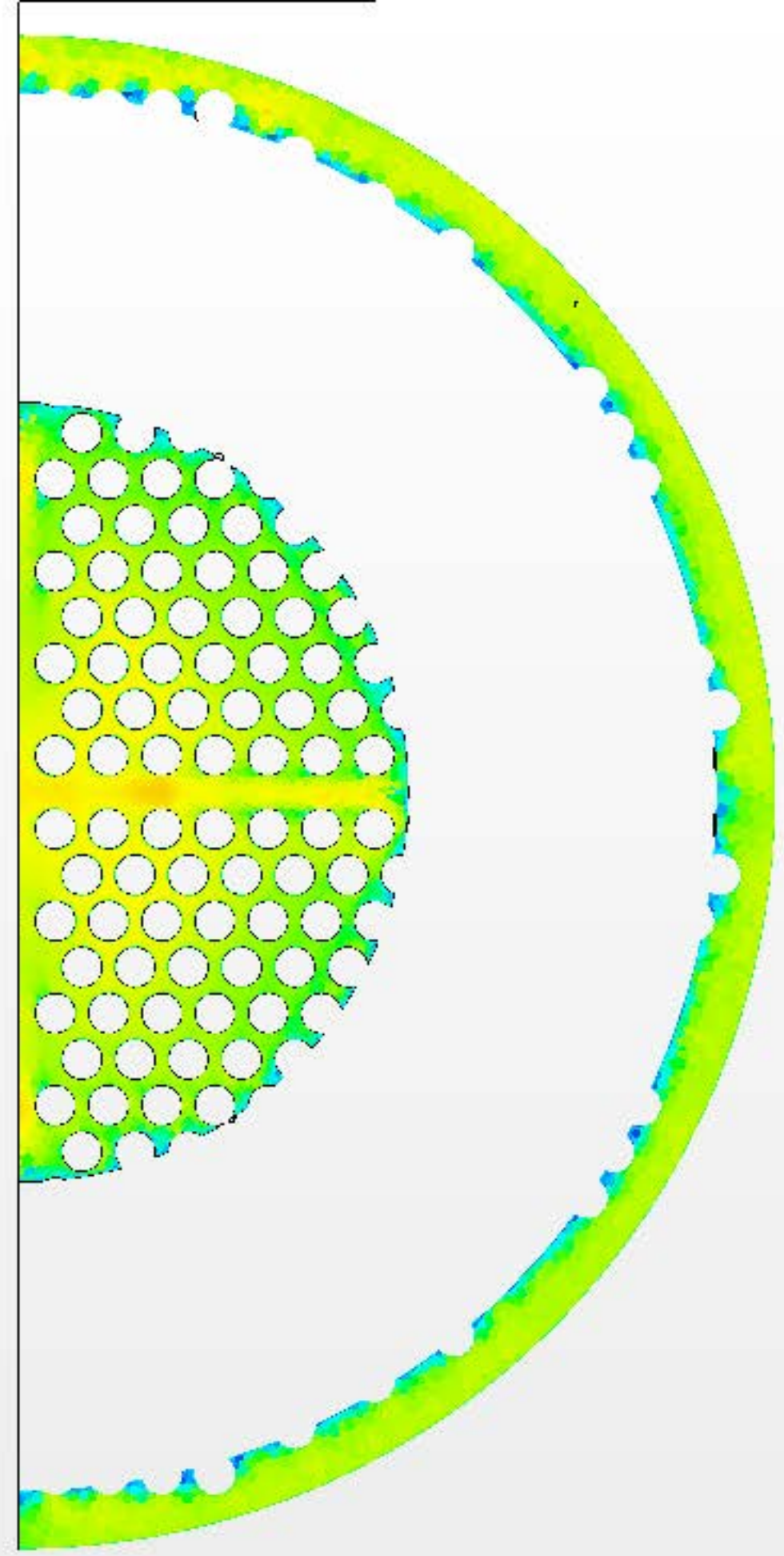
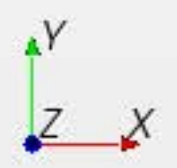

Velocity: Magnitude (m/s)

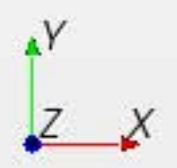
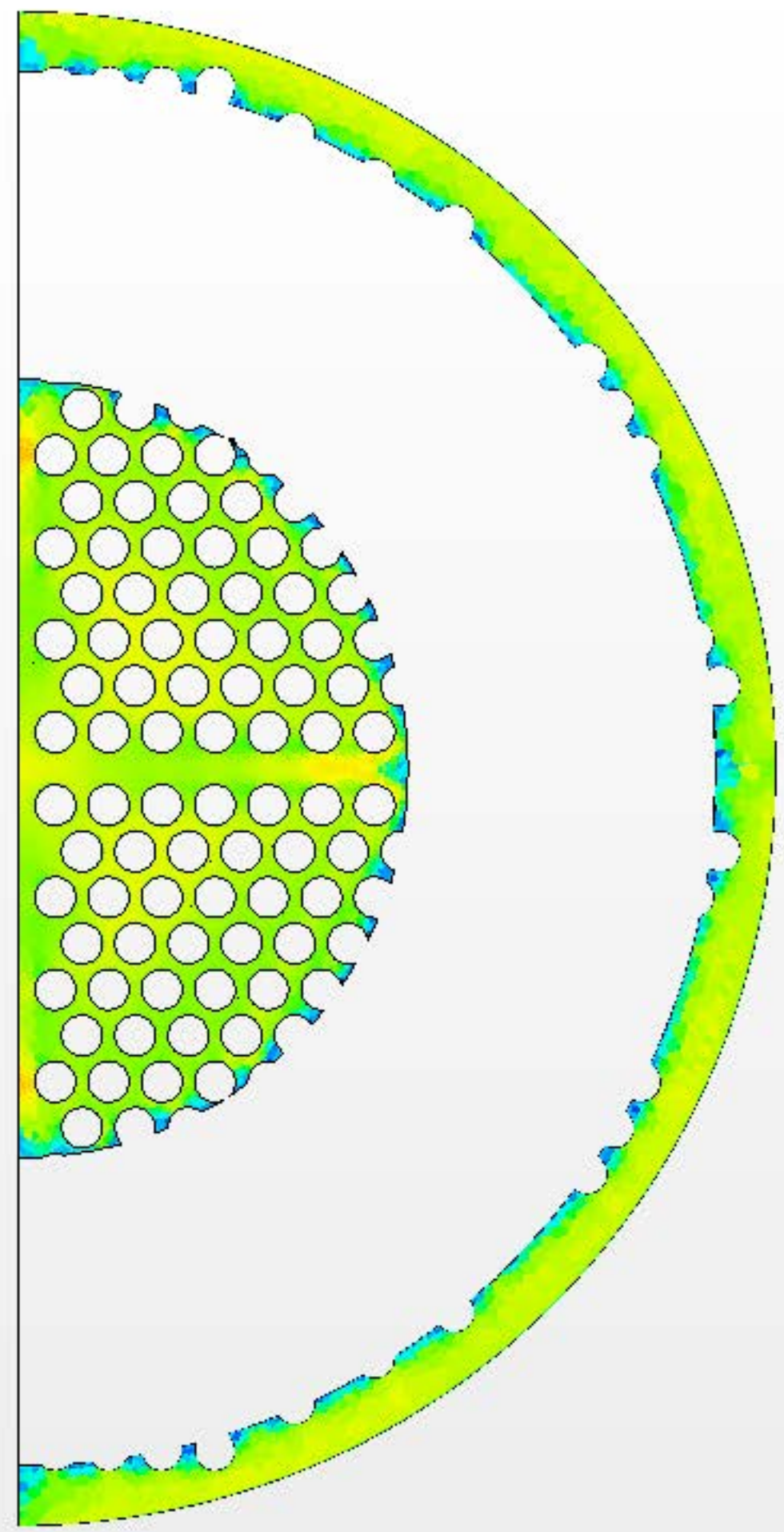

Velocity: Magnitude (m/s)

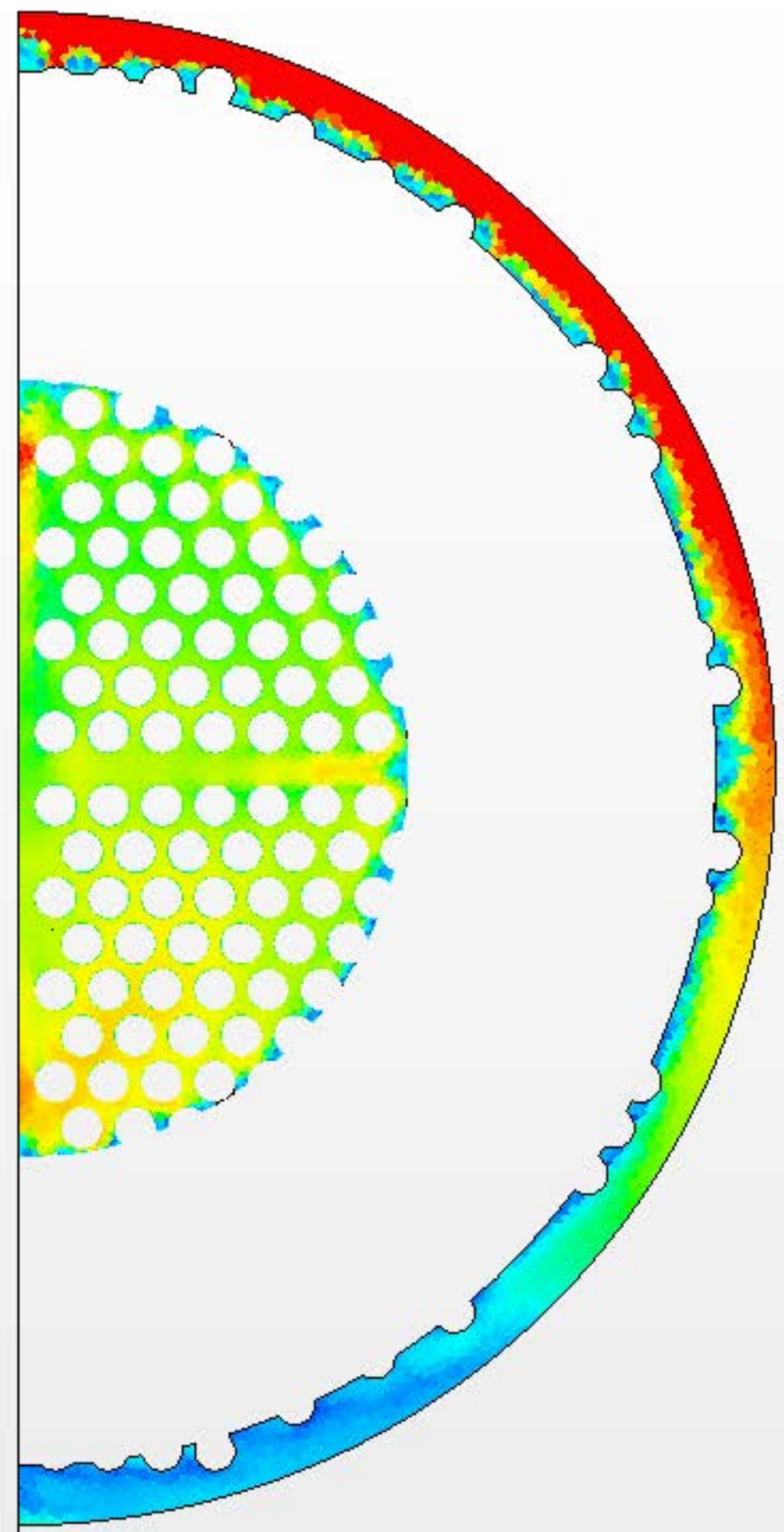
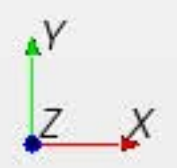

Velocity: Magnitude (m/s)

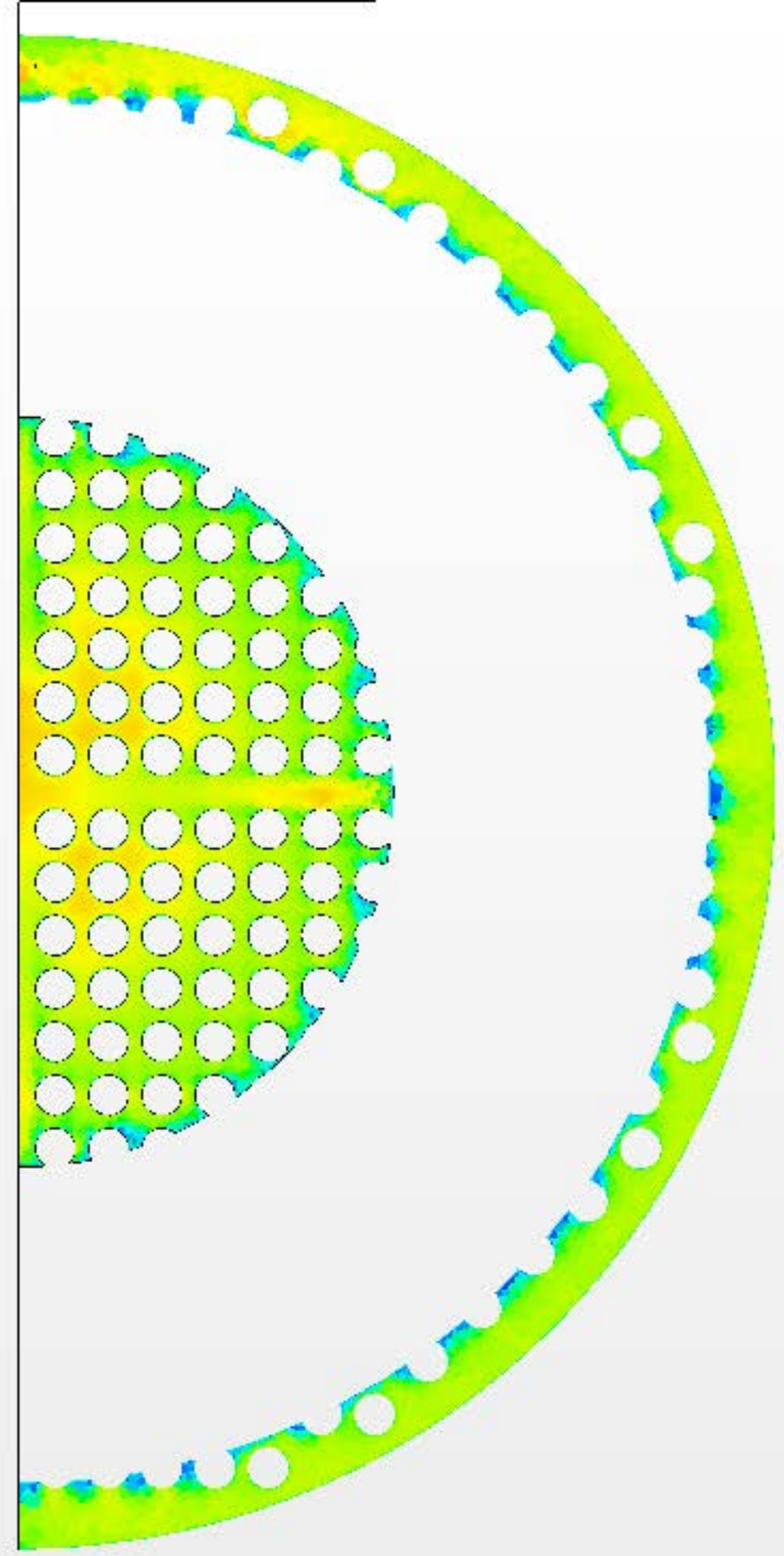
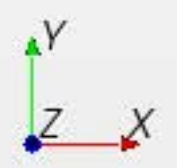

Velocity: Magnitude (m/s)

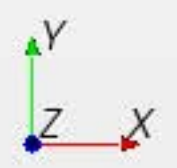
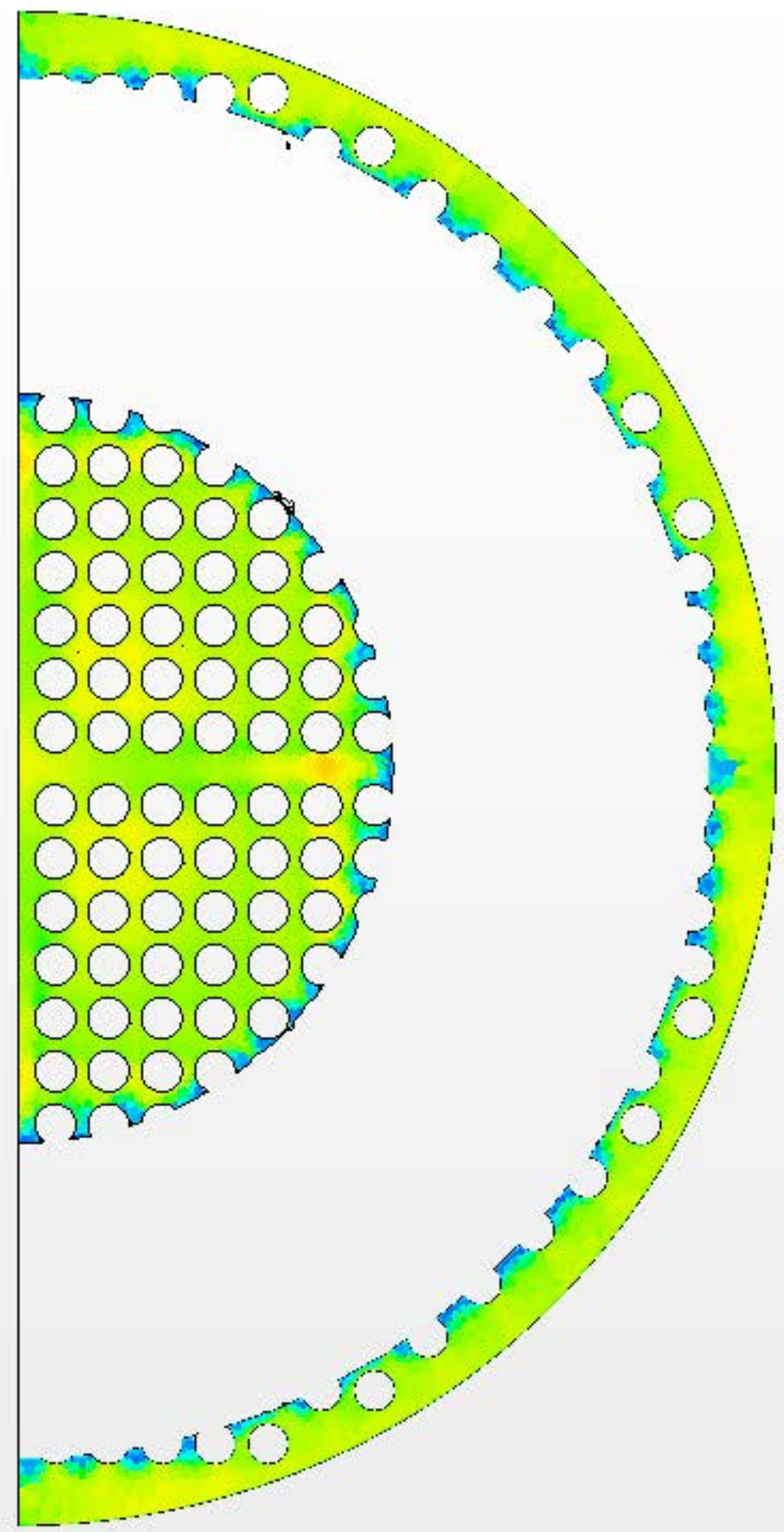

Velocity: Magnitude (m/s)

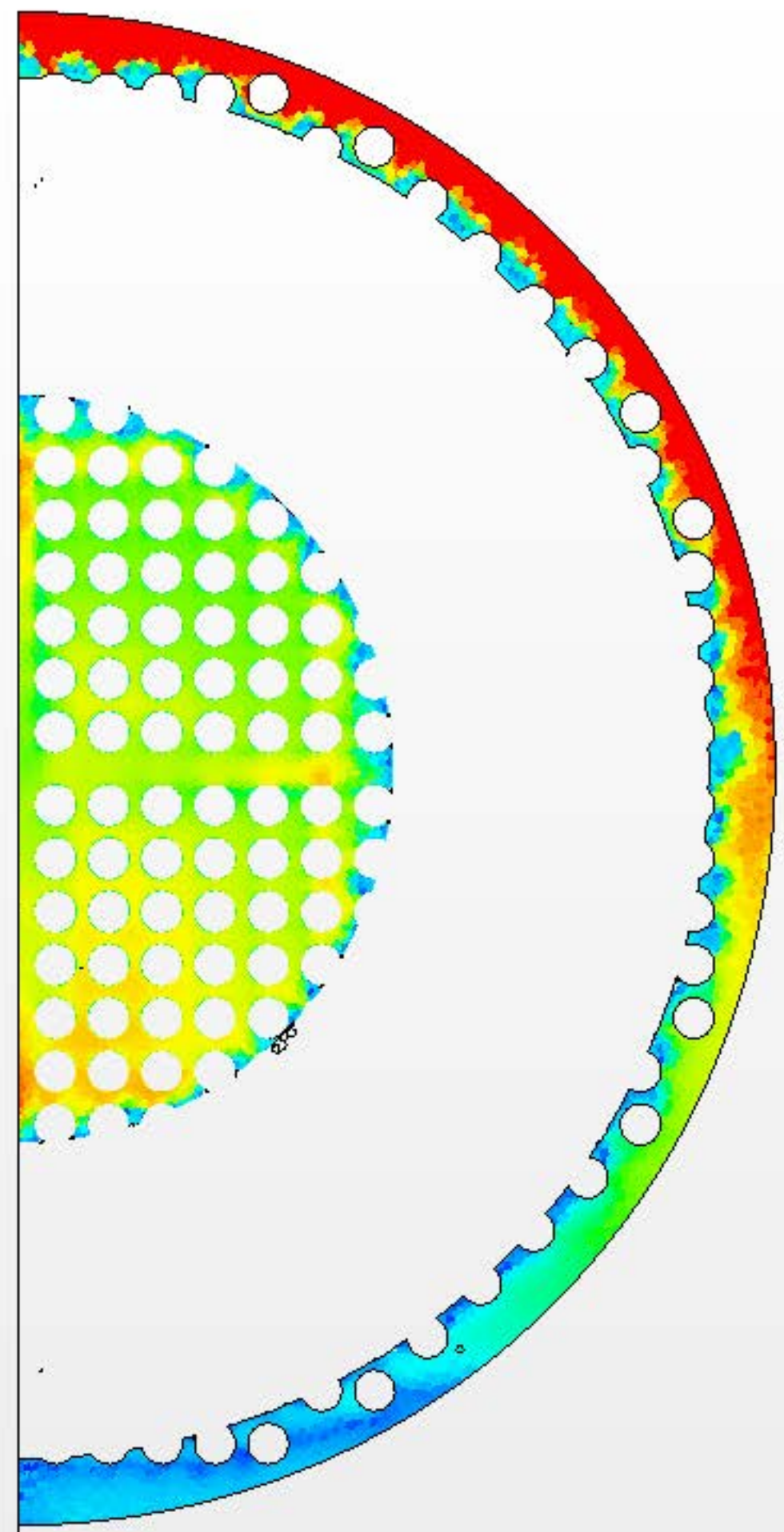
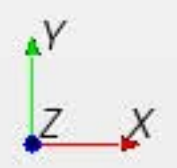

Velocity: Magnitude (m/s)

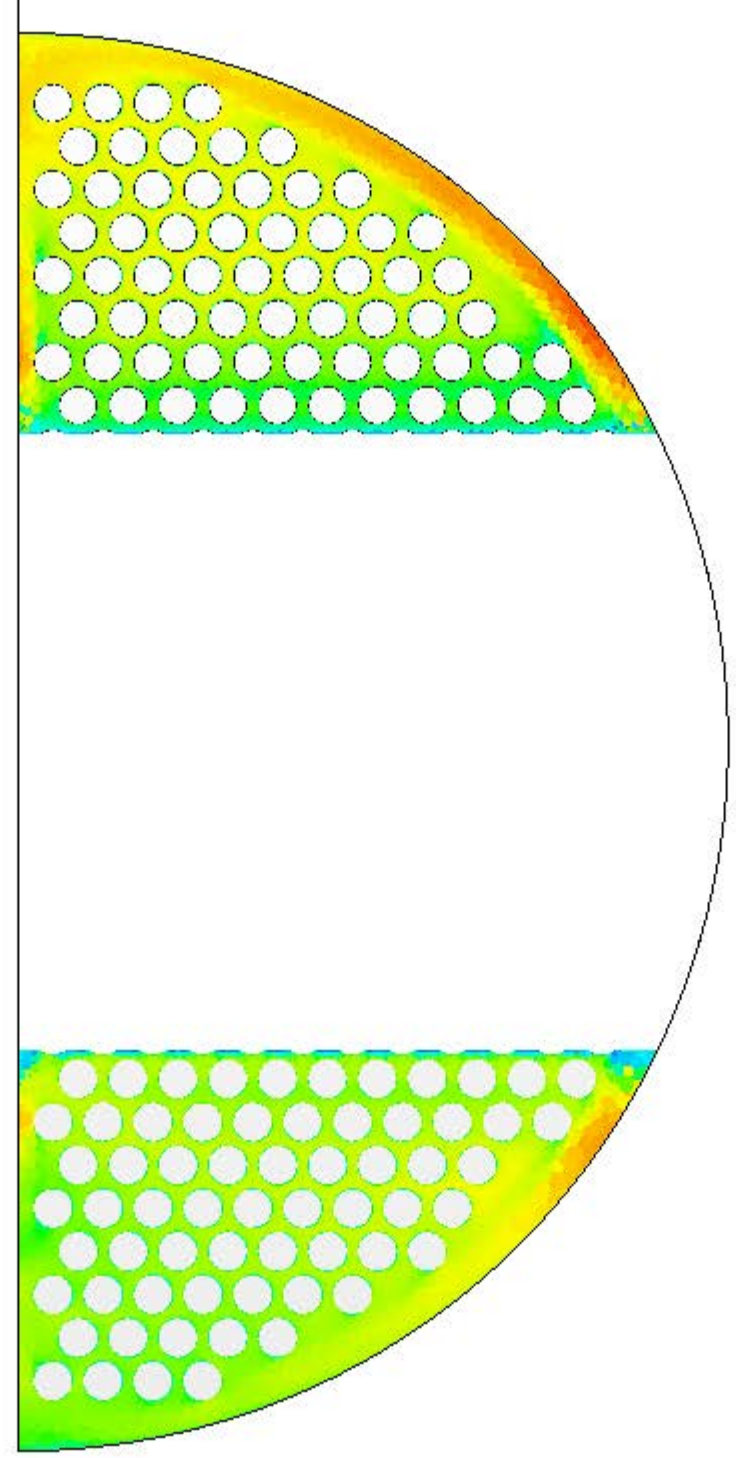
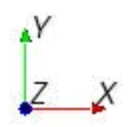
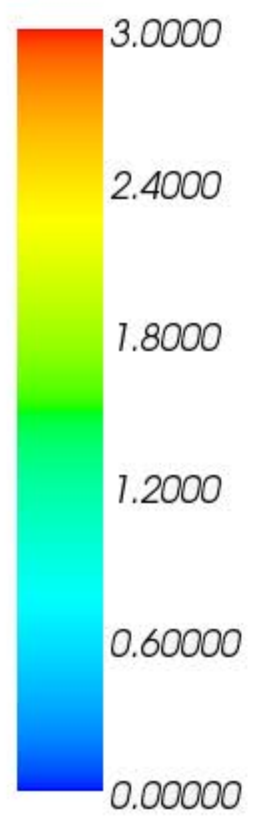

Velocity: Magnitude (m/s)

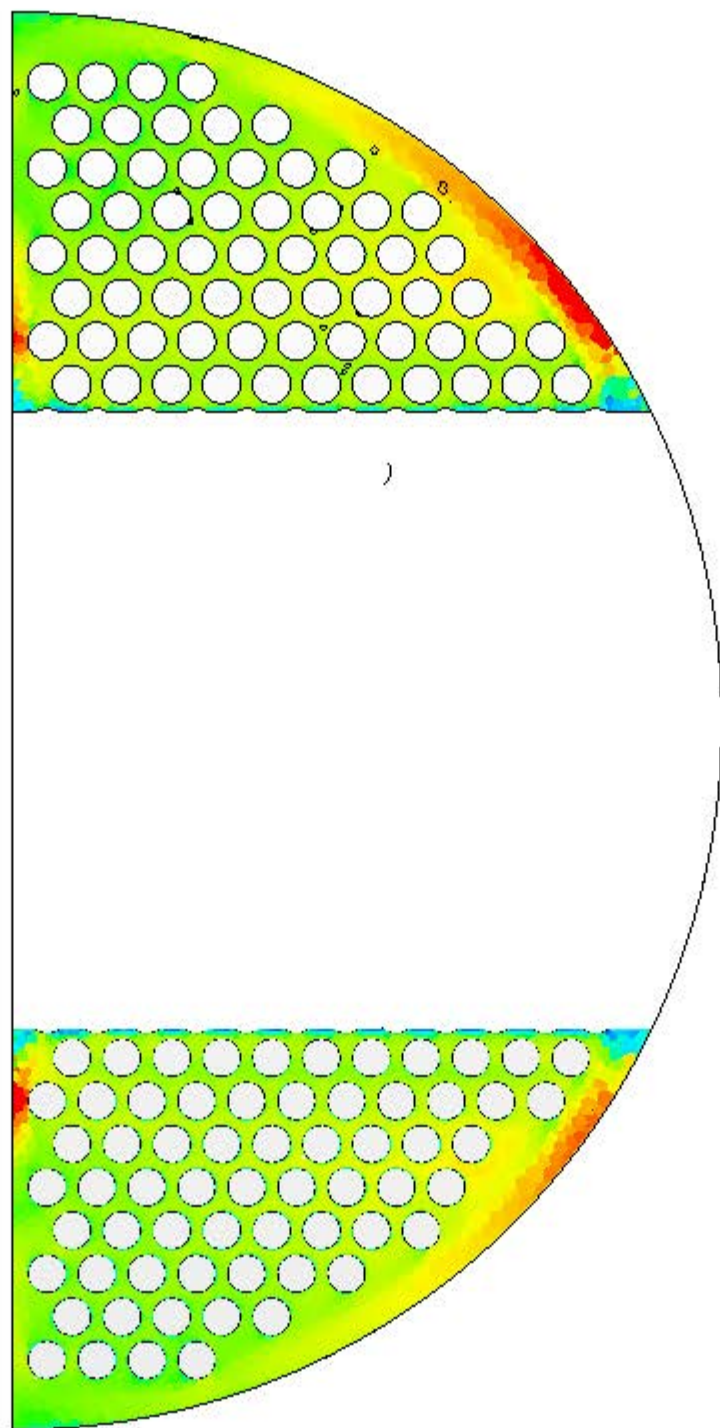
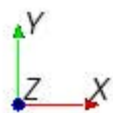
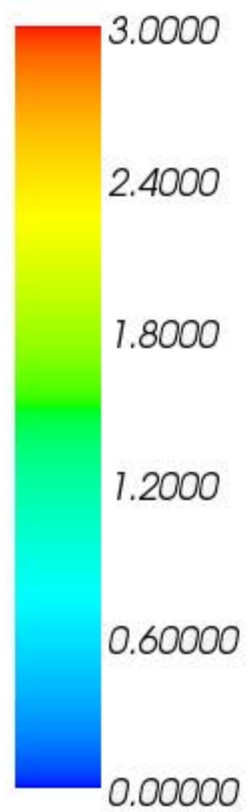

Velocity: Magnitude (m/s)

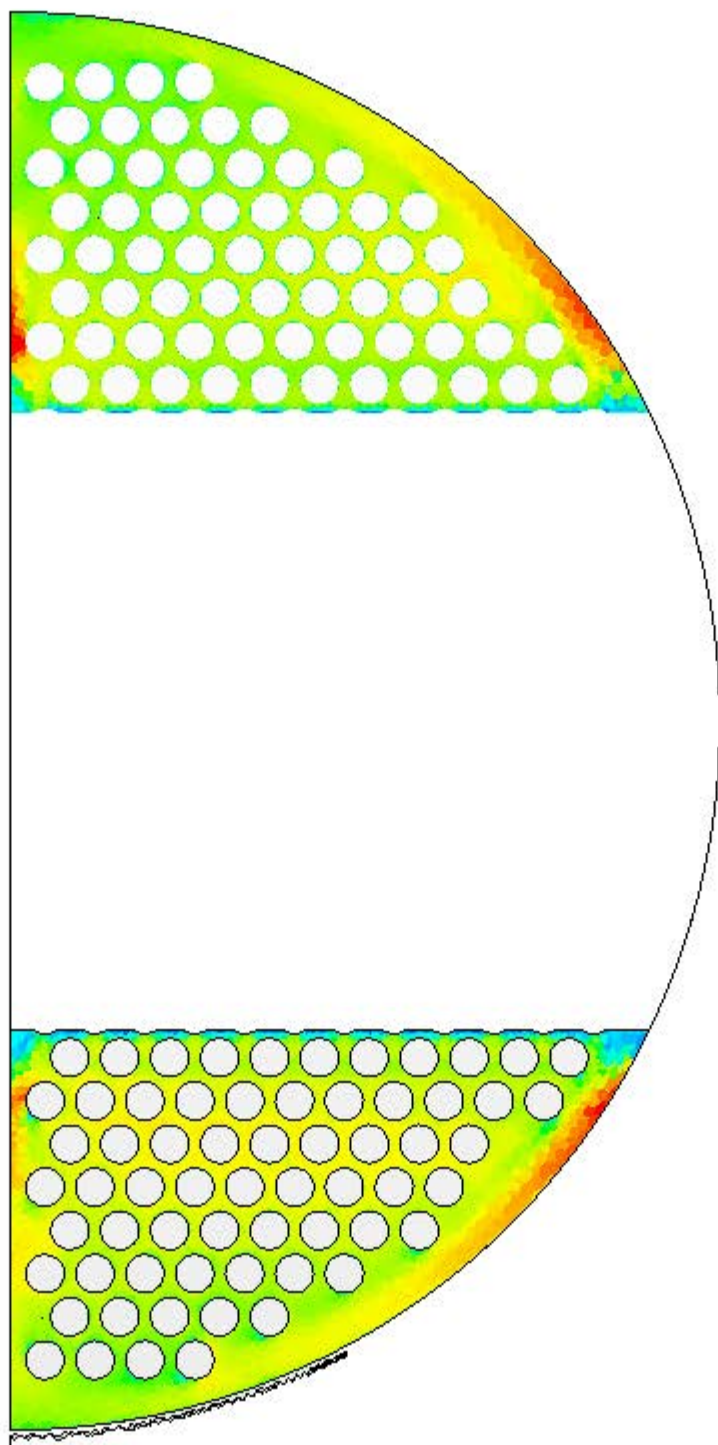
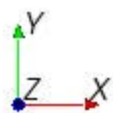
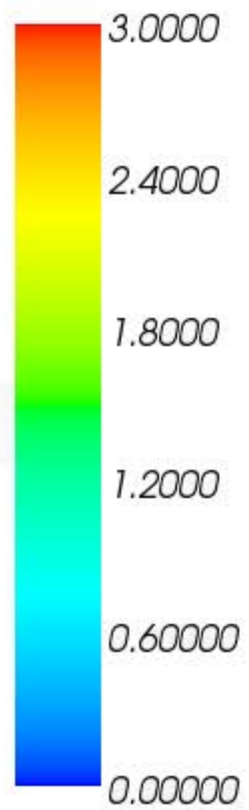

Velocity: Magnitude (m/s)

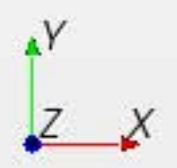
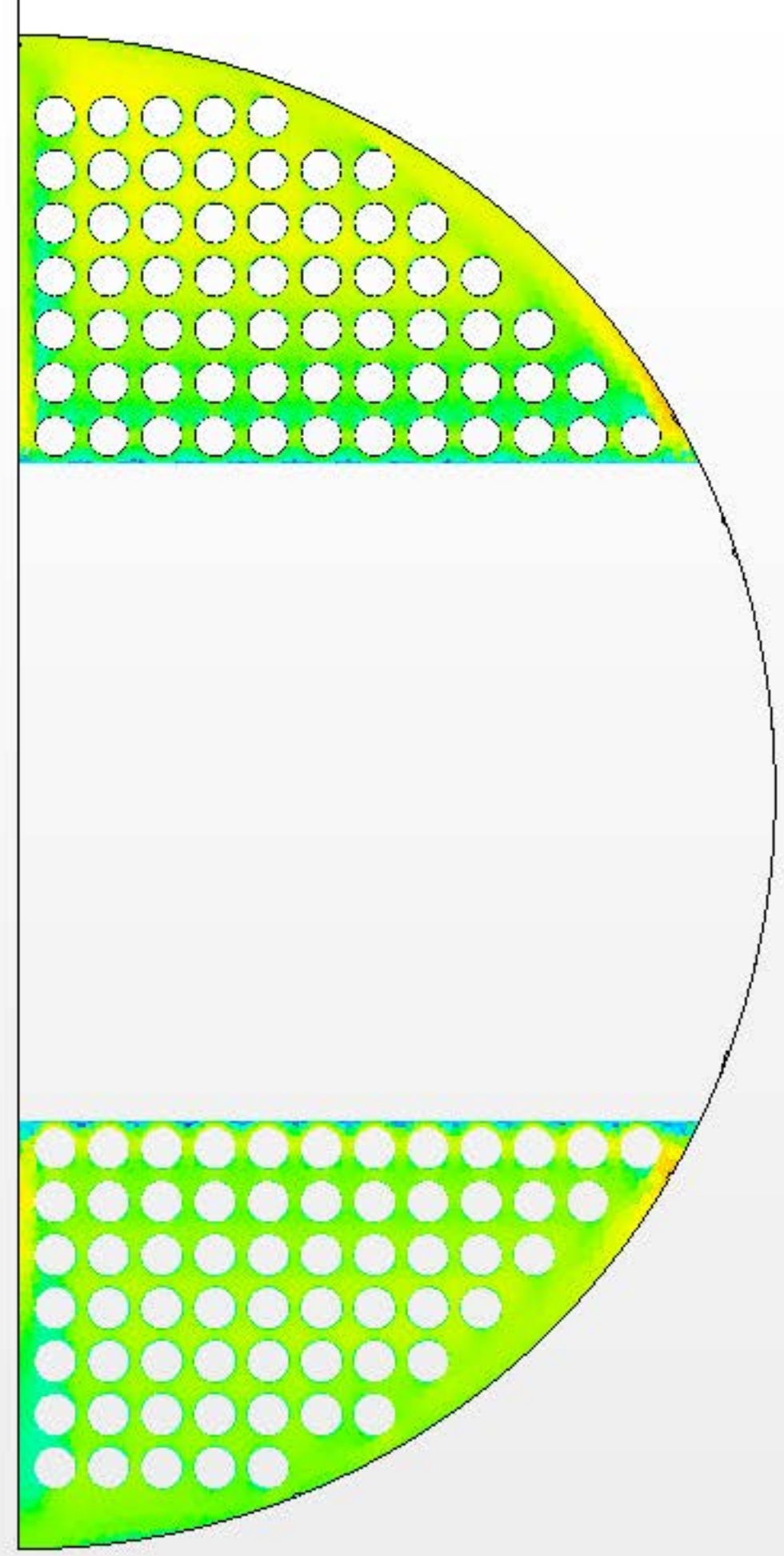

Velocity: Magnitude (m/s)

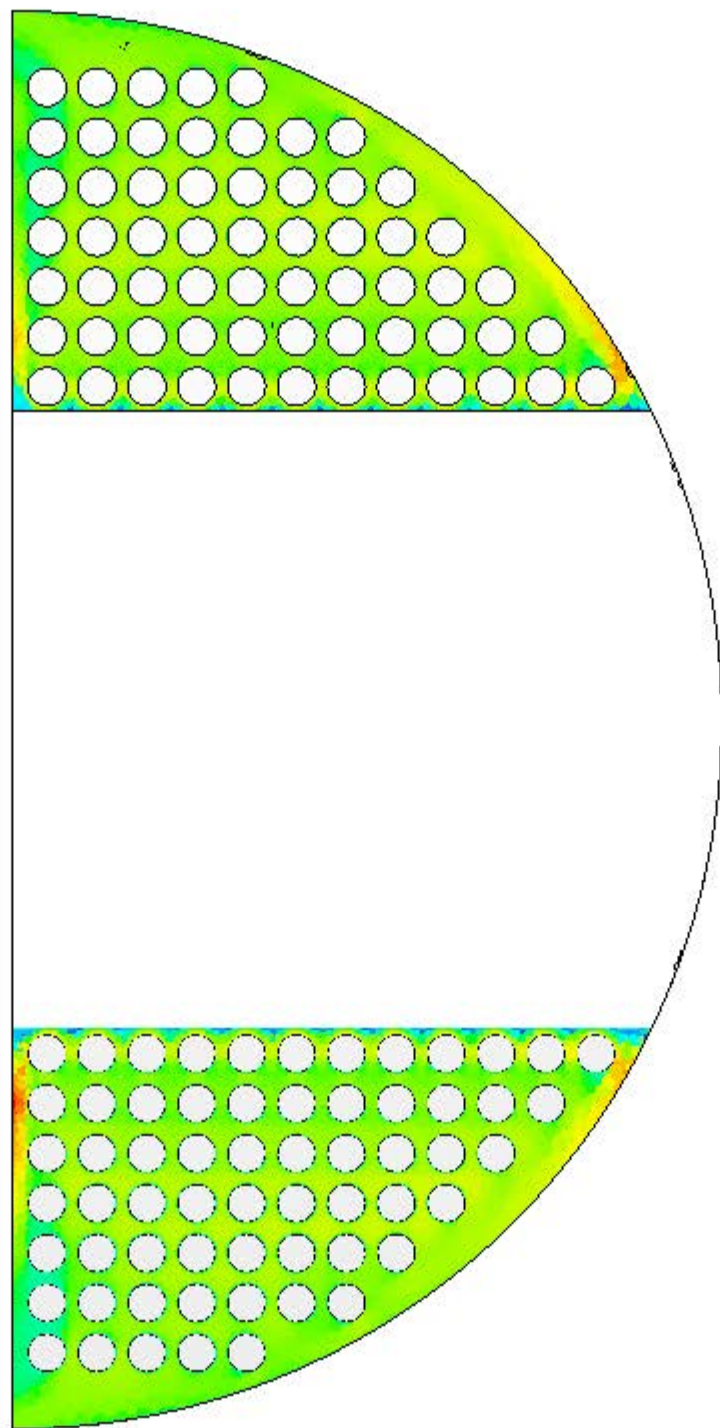
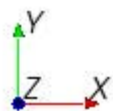
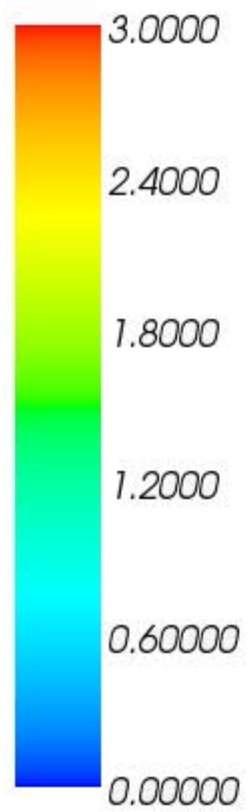

Velocity: Magnitude (m/s)

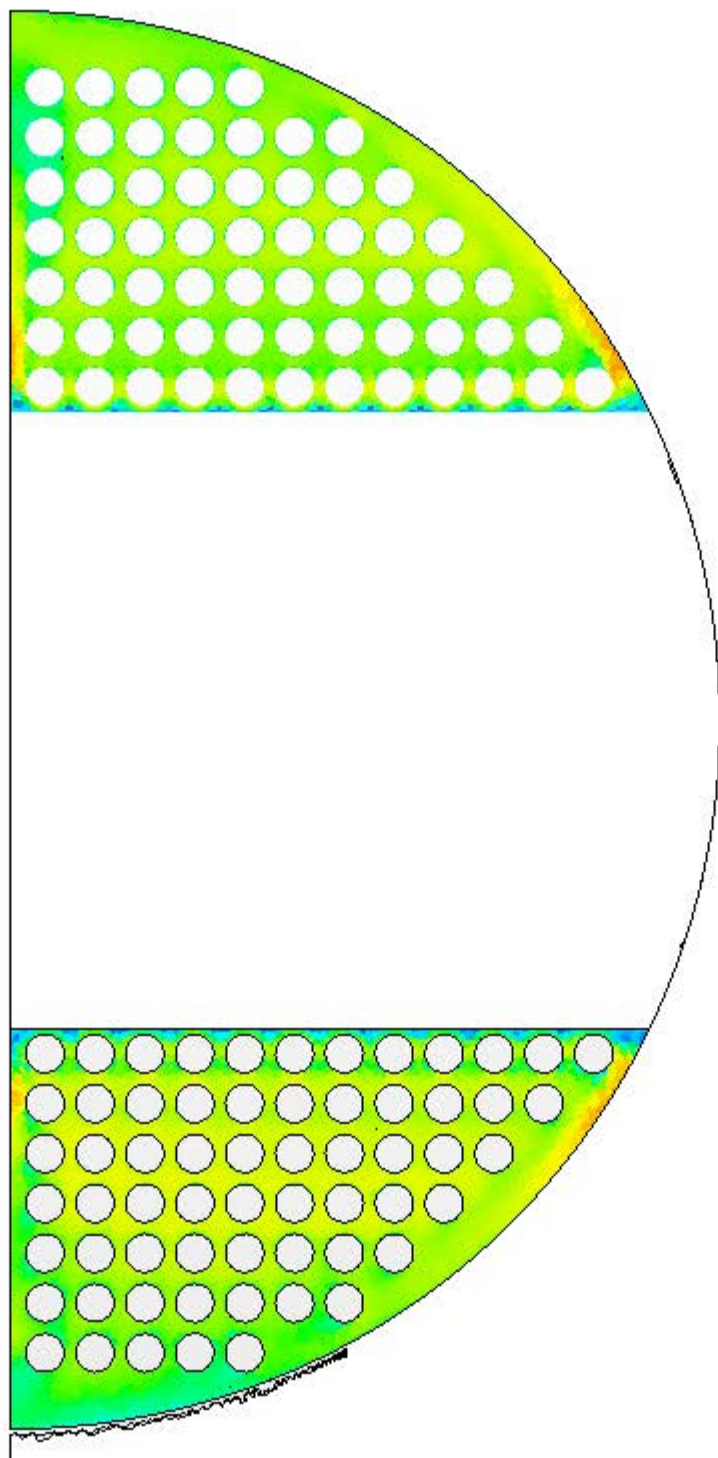
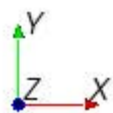
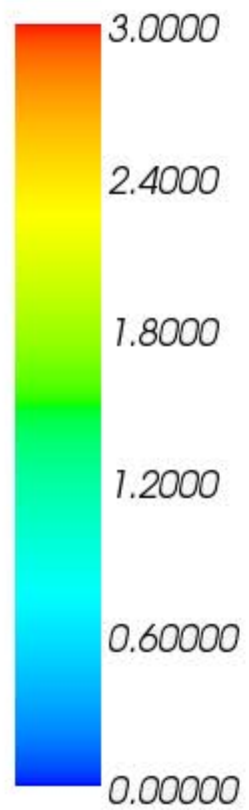

Velocity: Magnitude (m/s)

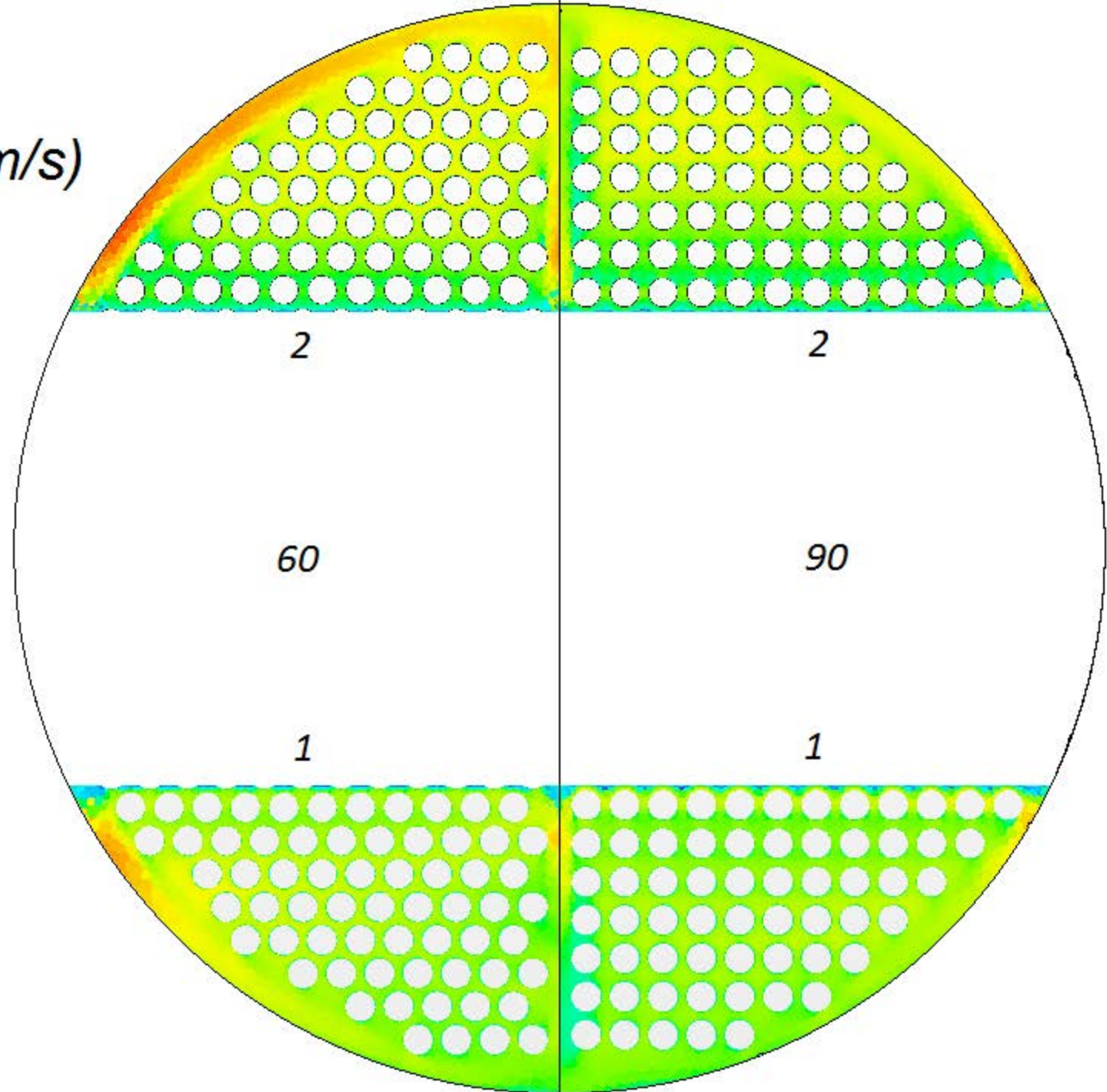
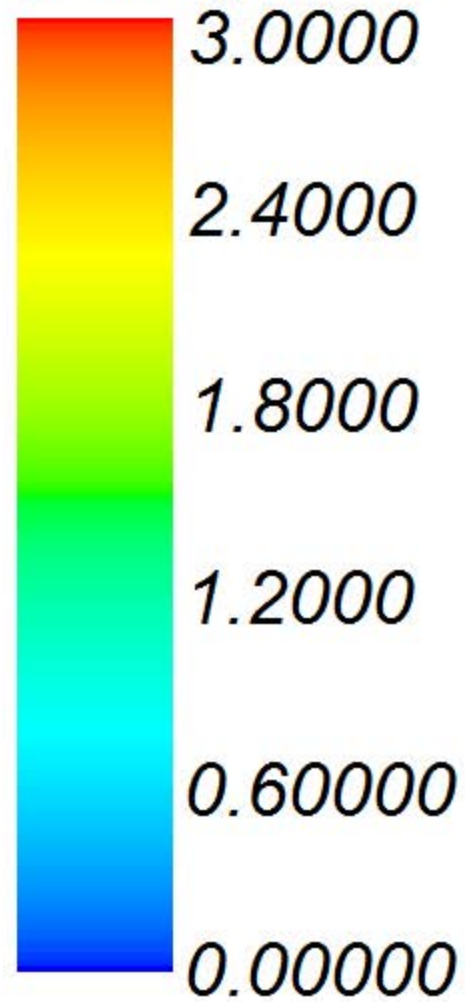

Velocity: Magnitude (m/s)

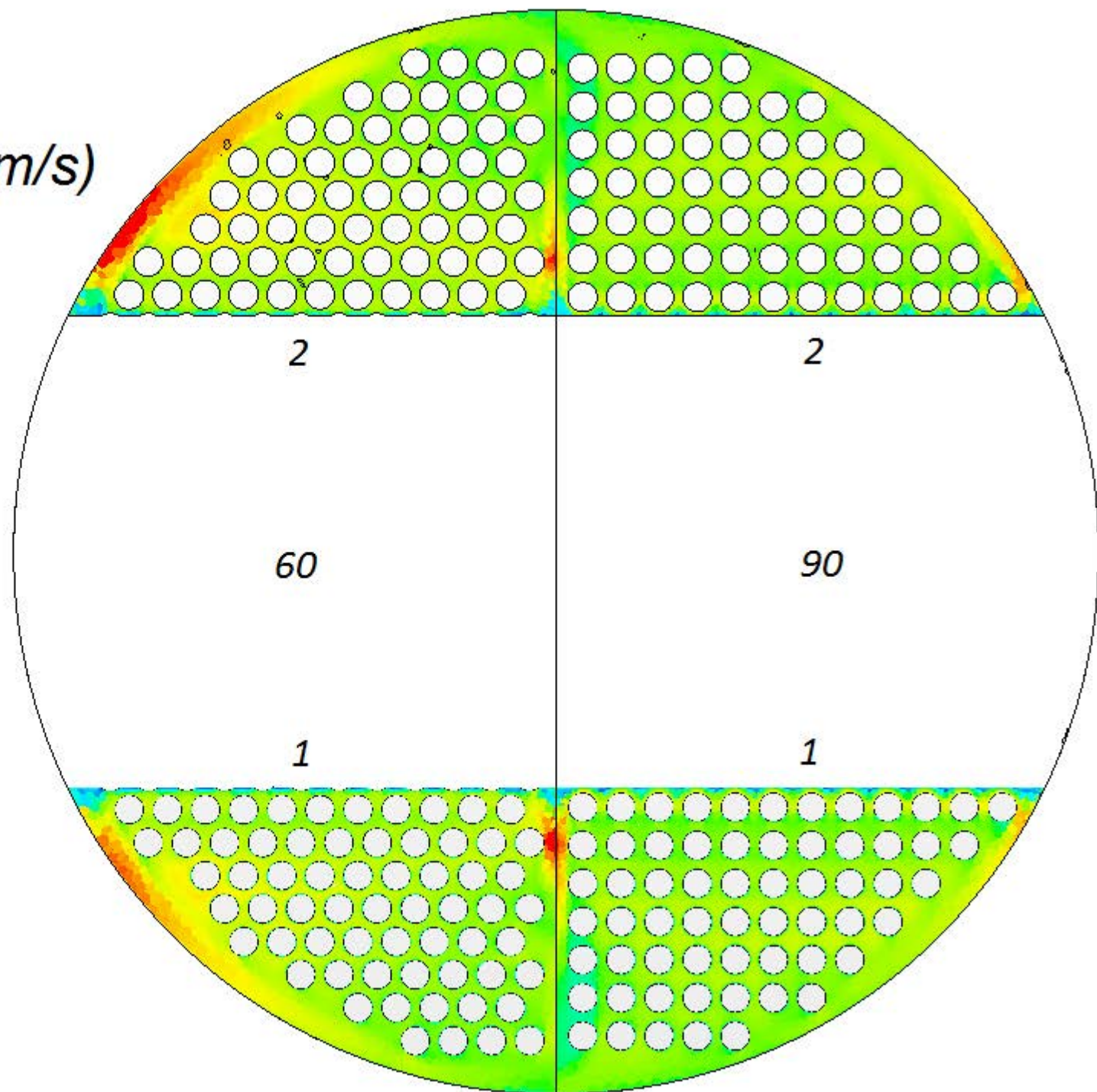
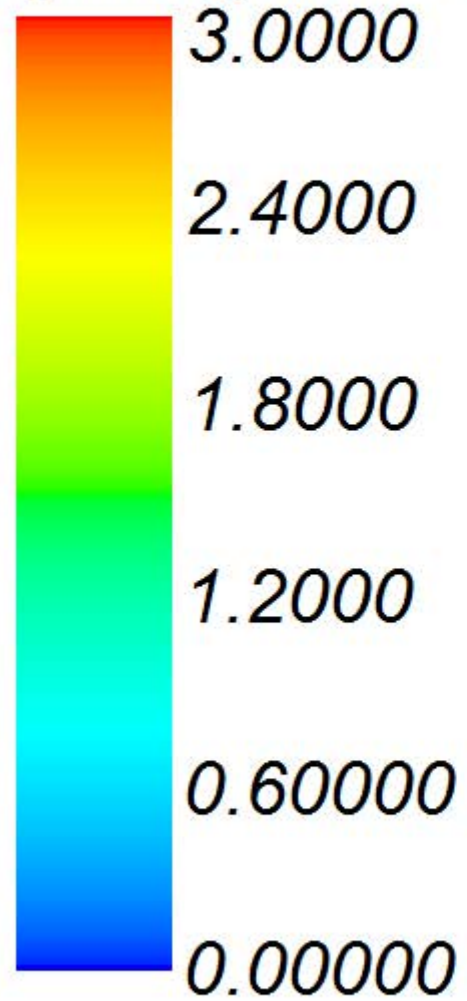

Velocity: Magnitude (m/s)

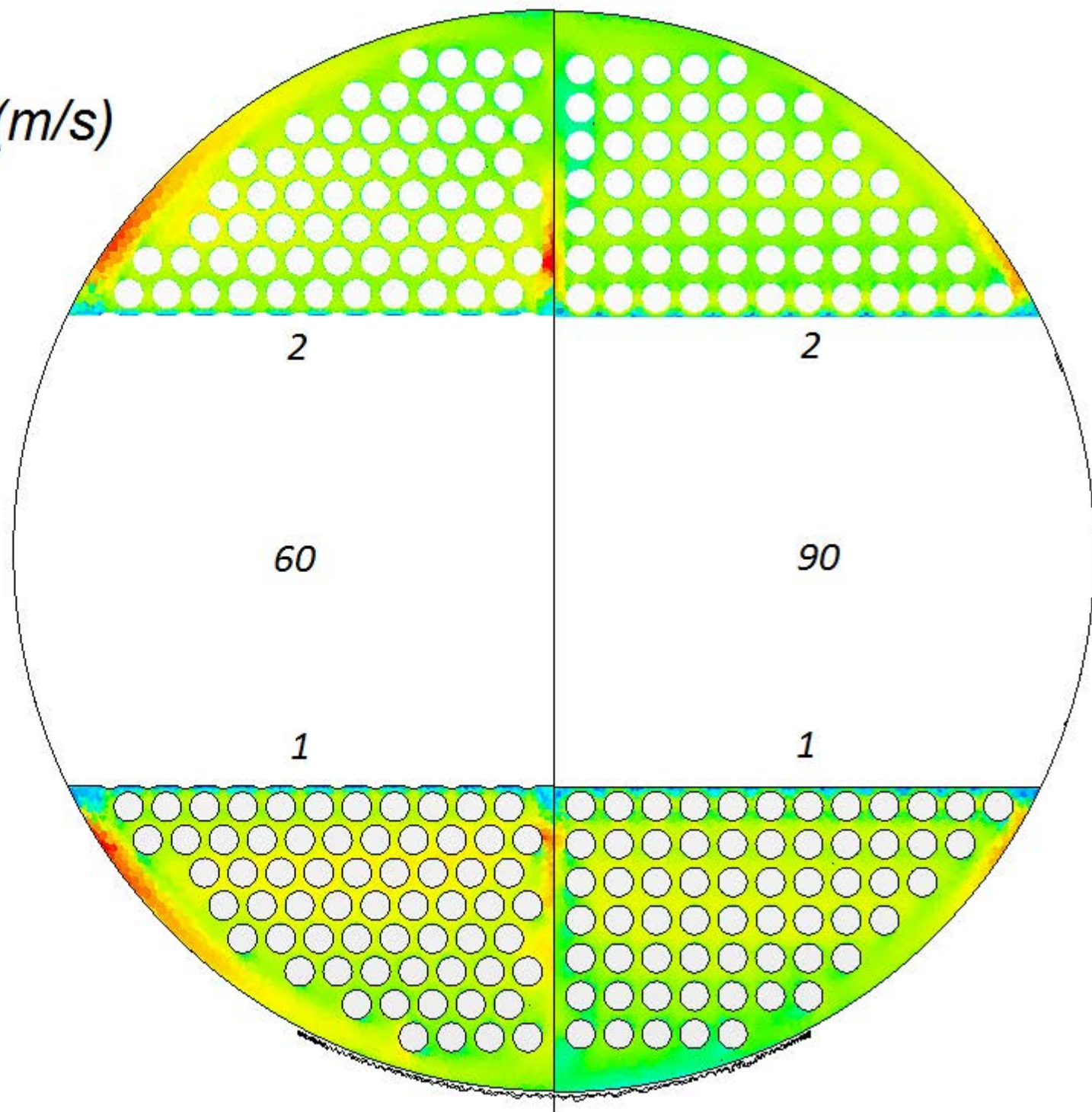
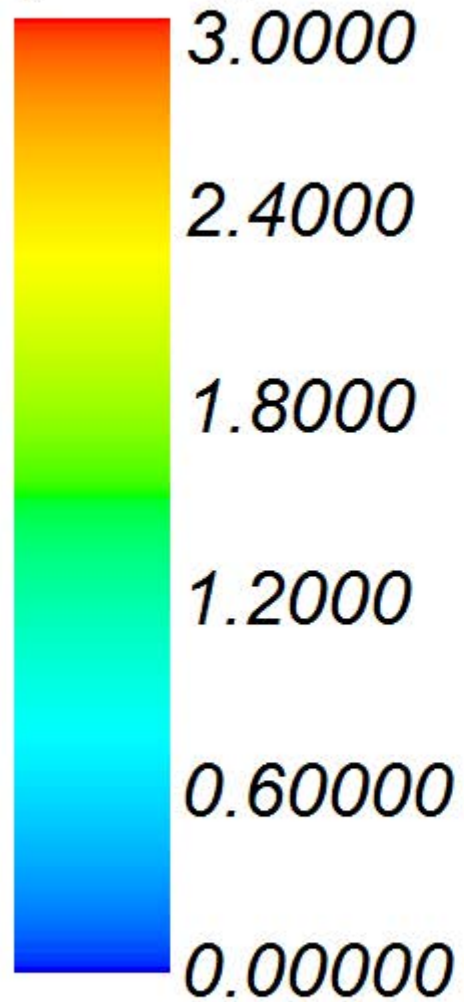

Appendix F

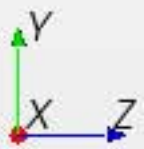
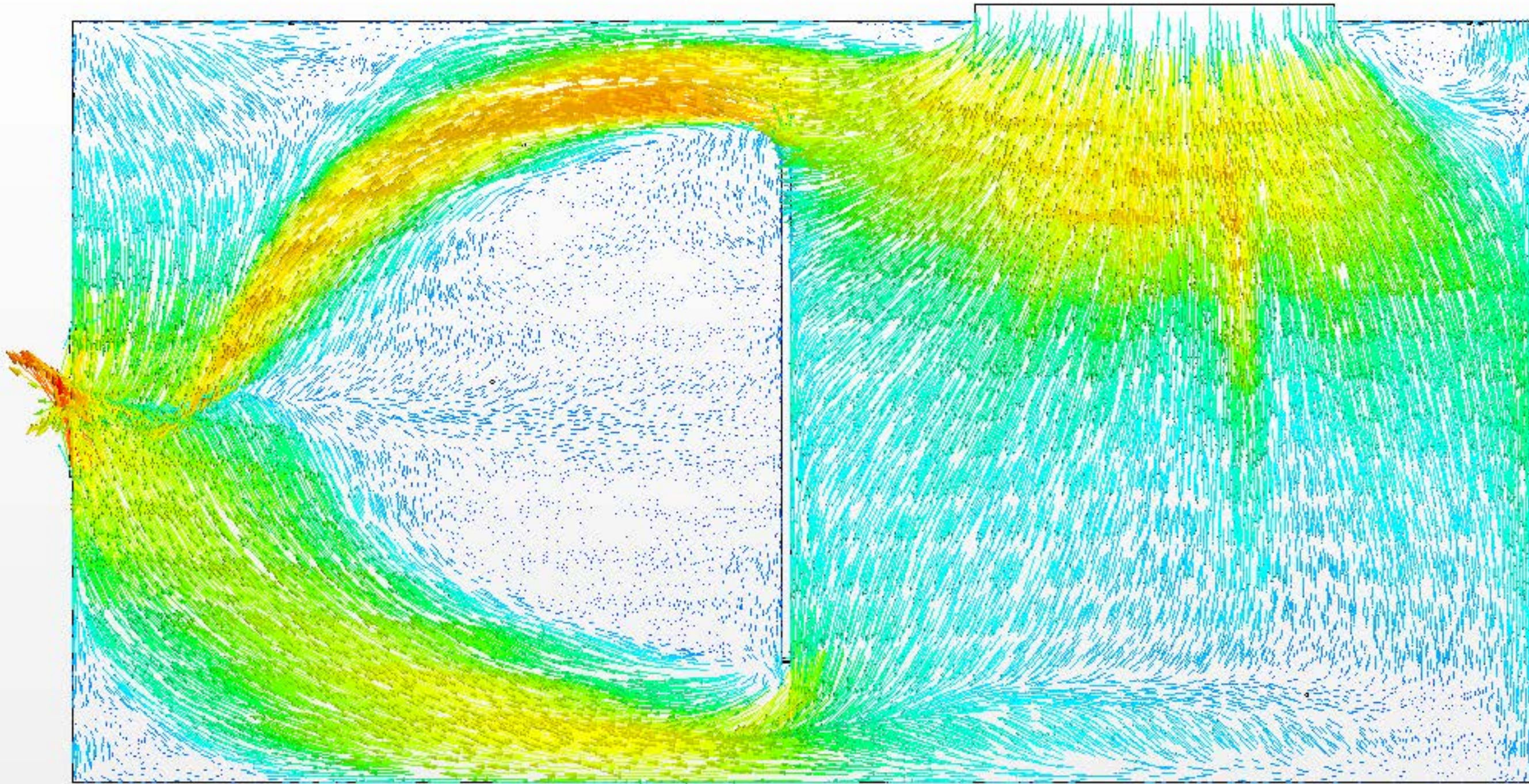

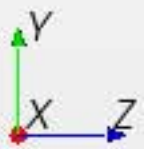
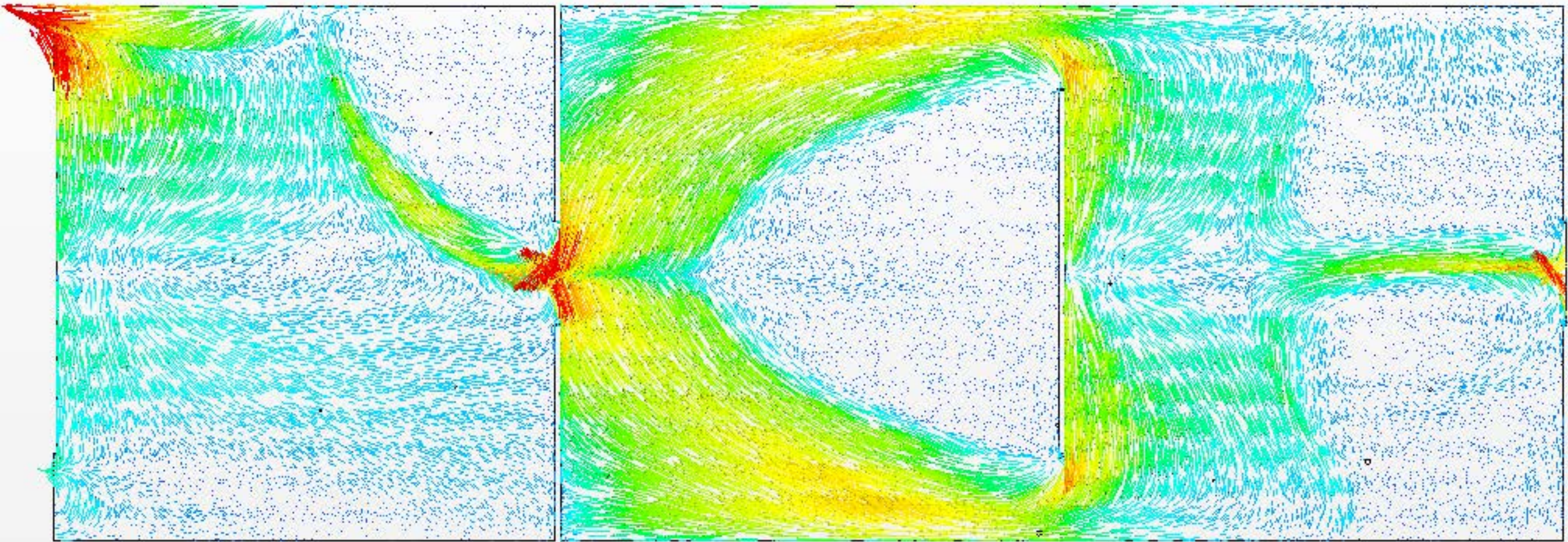

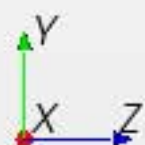
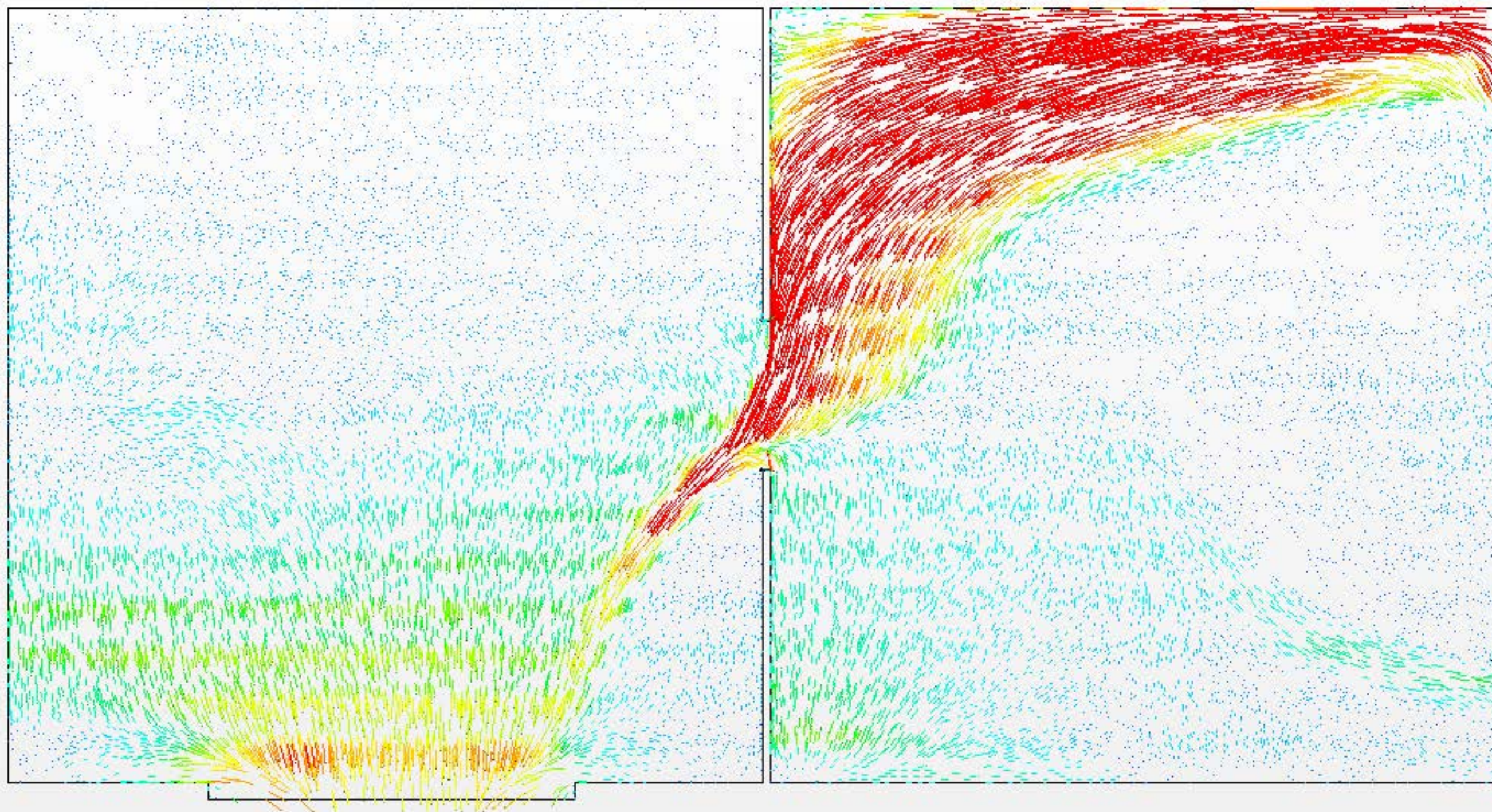

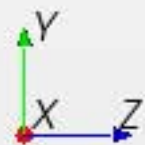
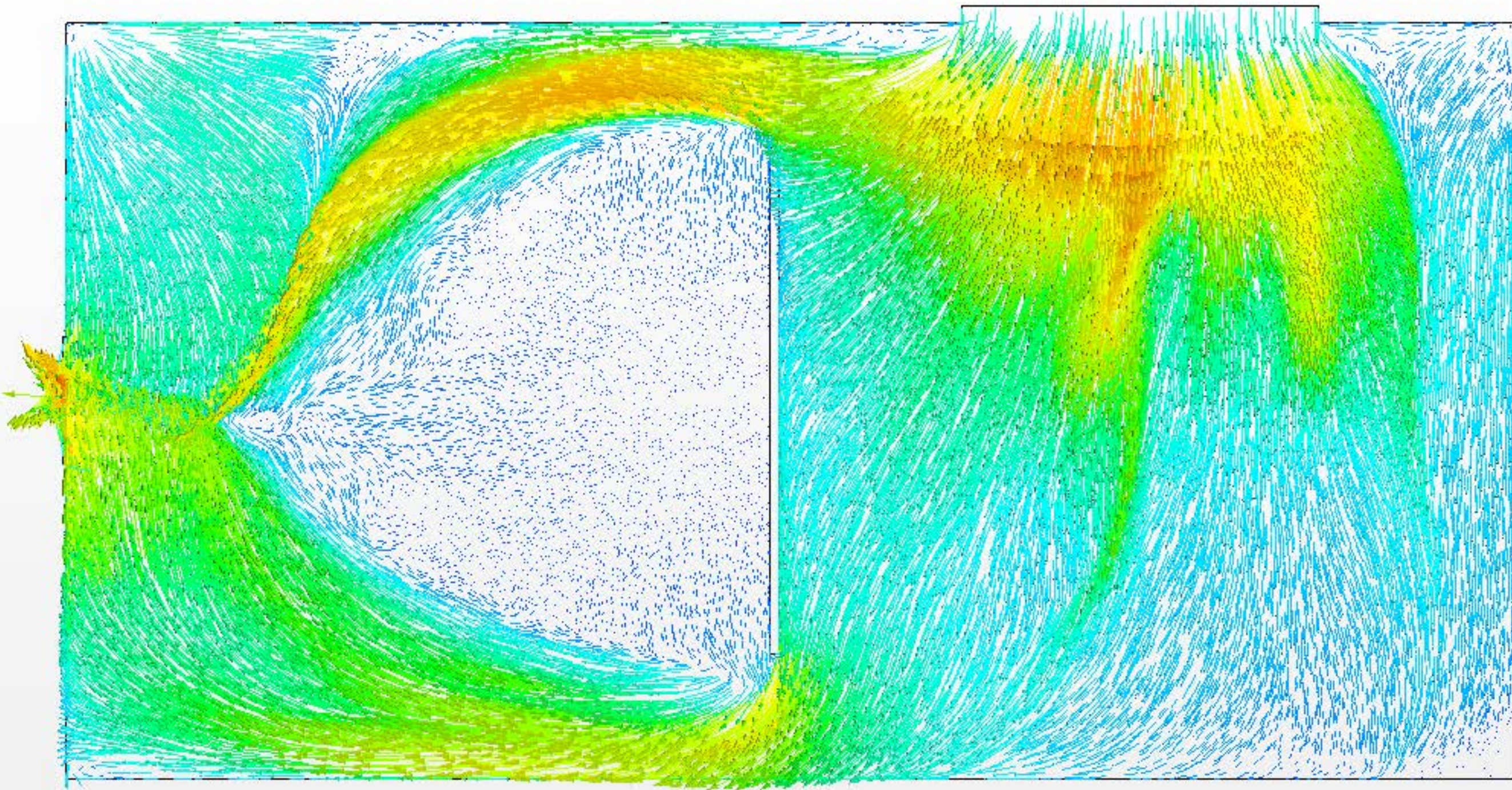

Velocity (m/s)

0.00000 0.60000 1.2000 1.8000 2.4000 3.0000



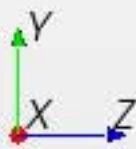
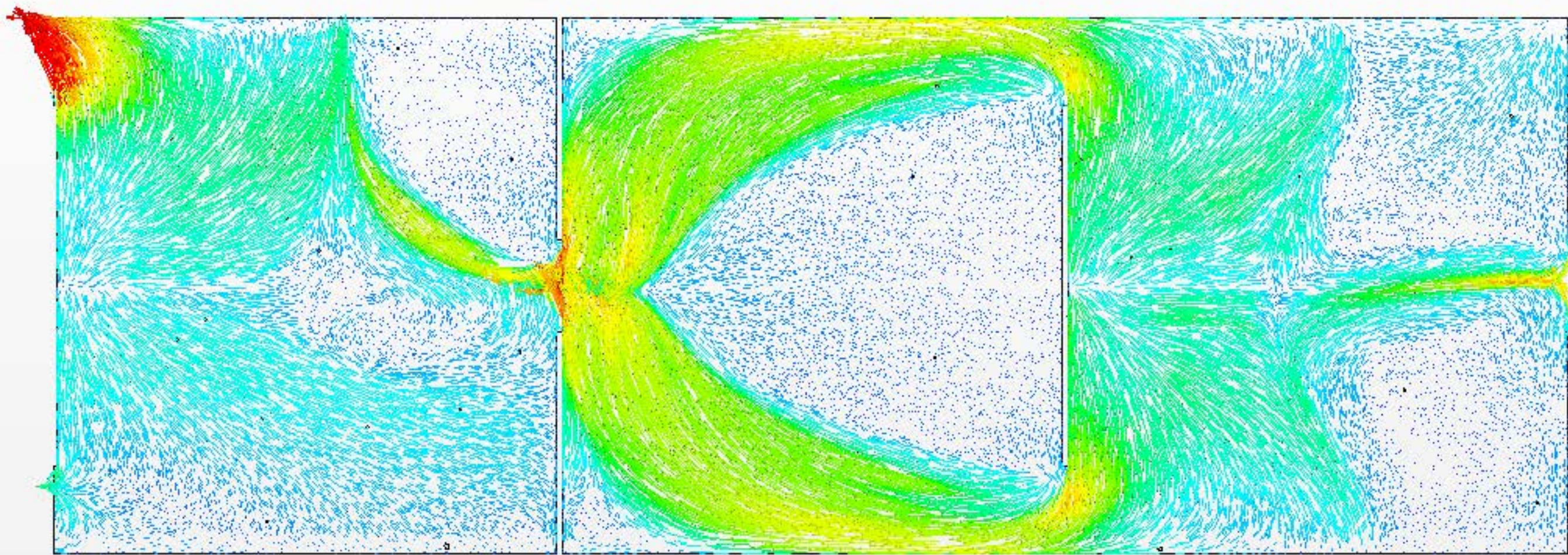

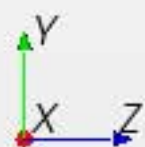
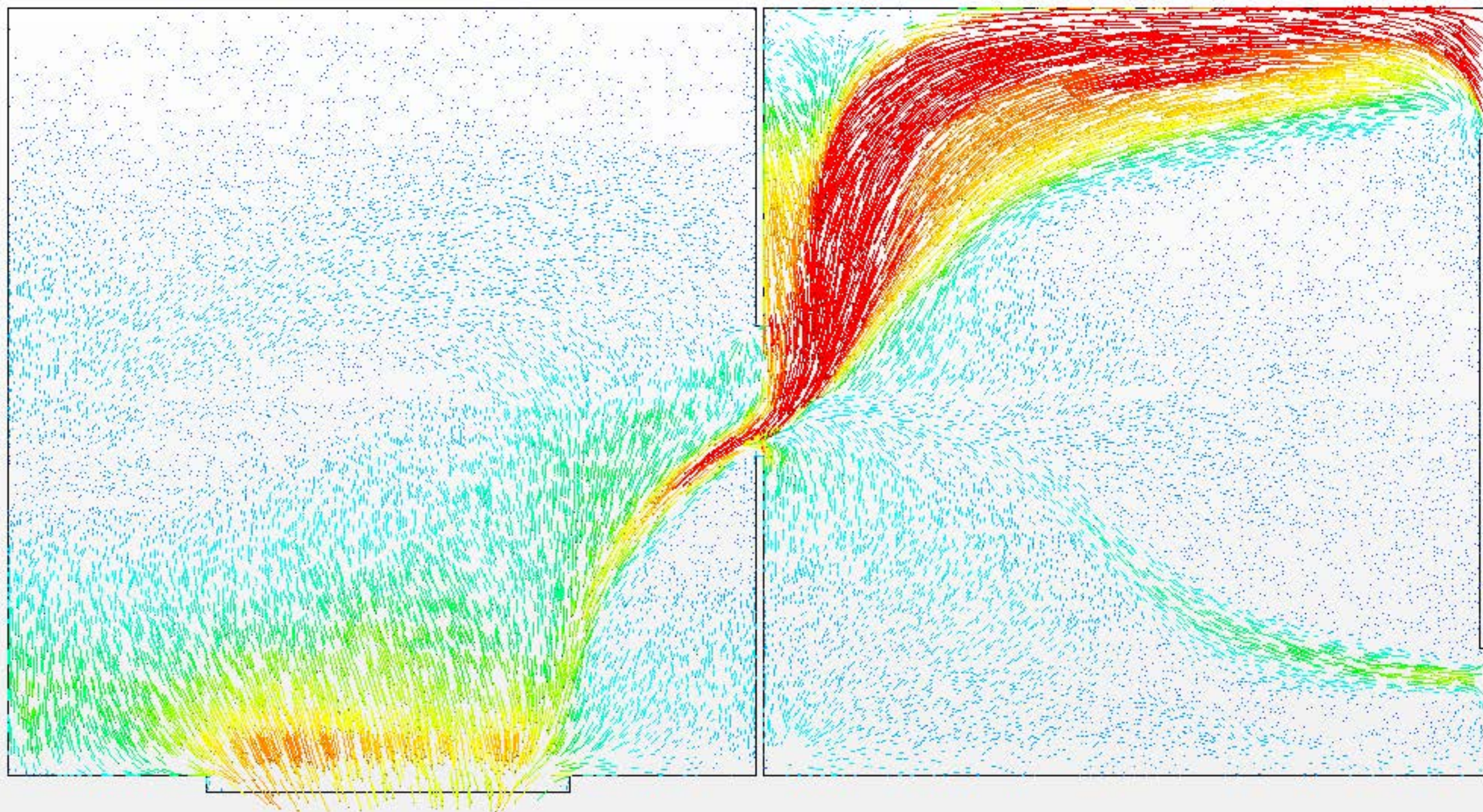

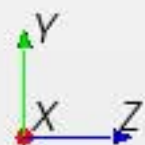
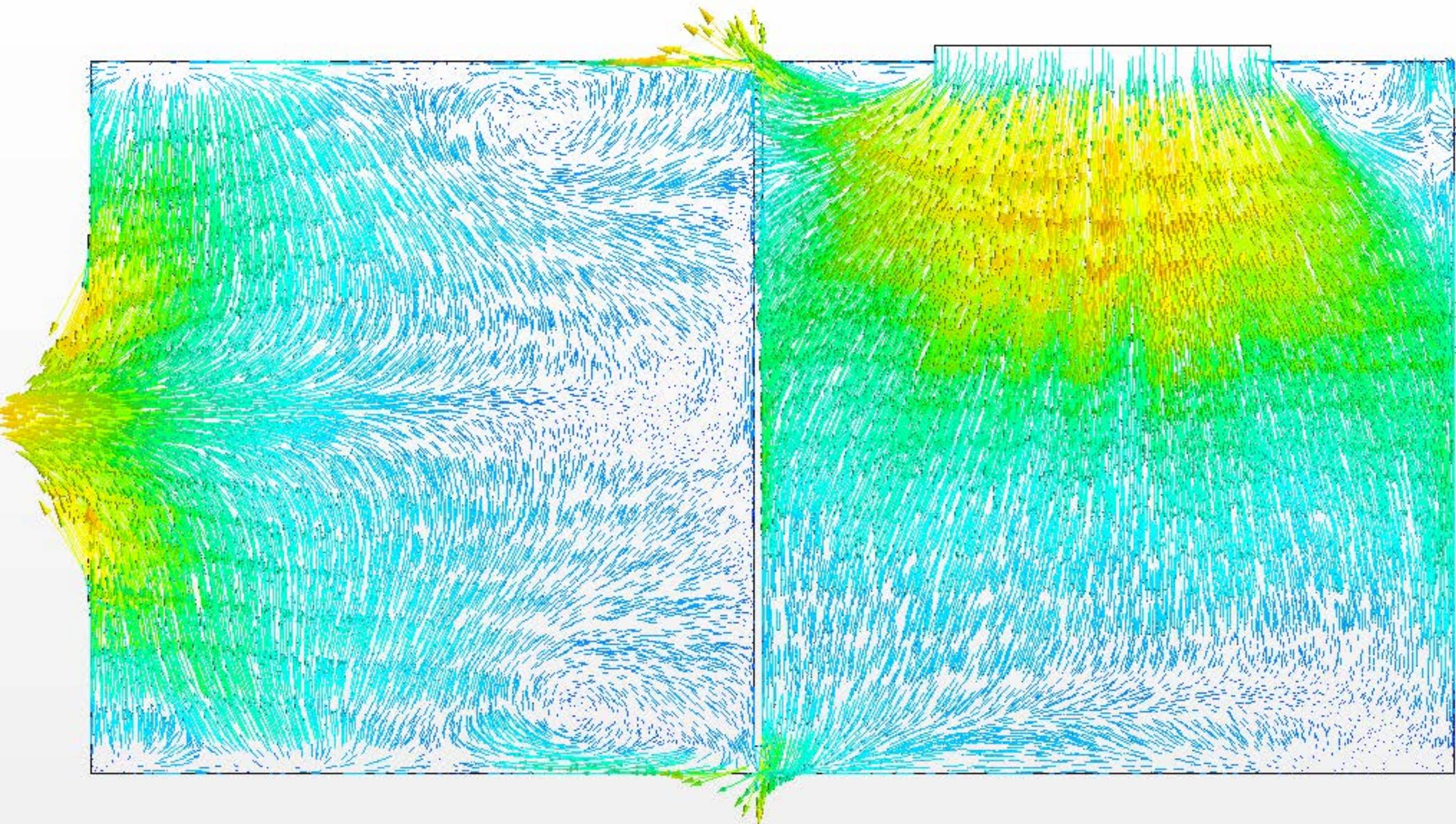

Velocity (m/s)

0.00000	0.60000	1.2000	1.8000	2.4000	3.0000
---------	---------	--------	--------	--------	--------



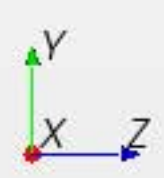
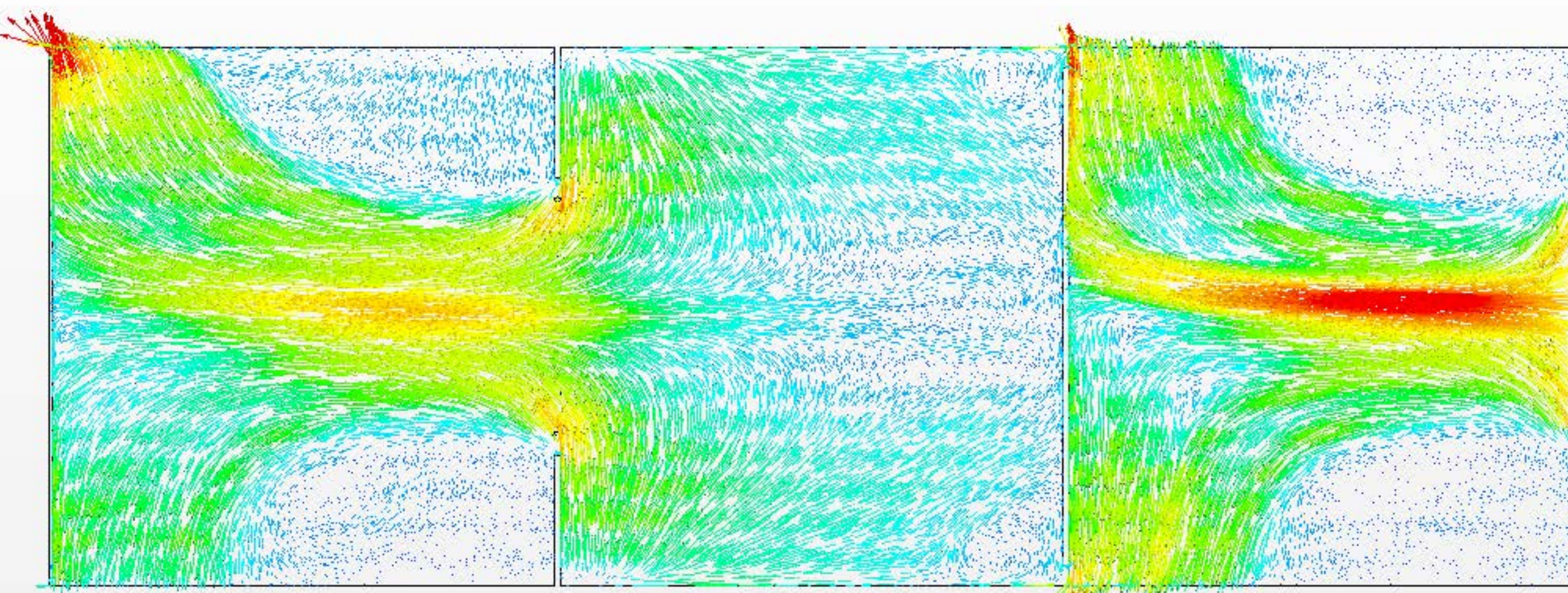

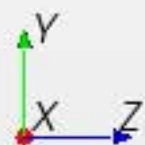
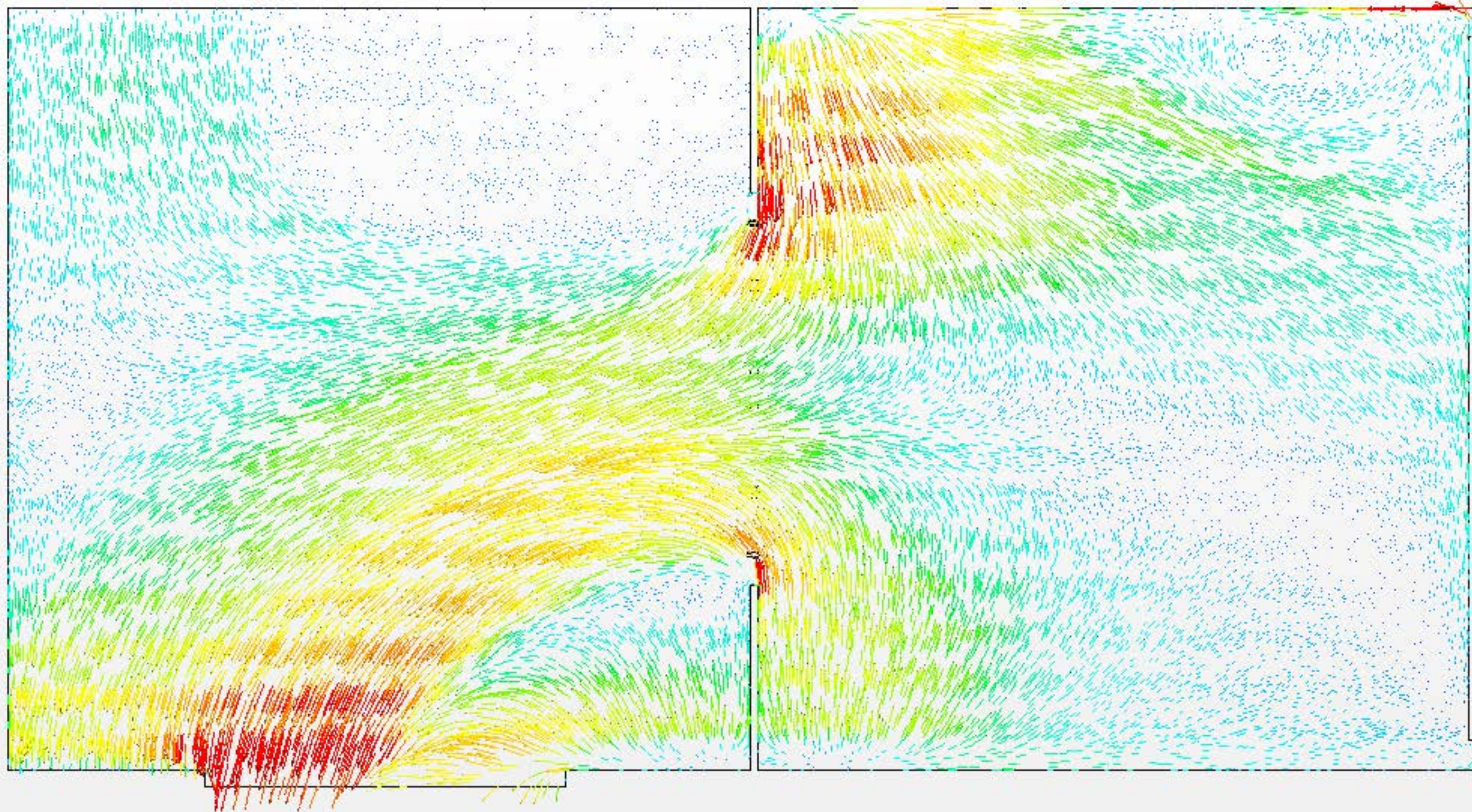

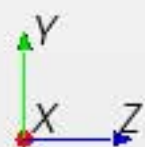
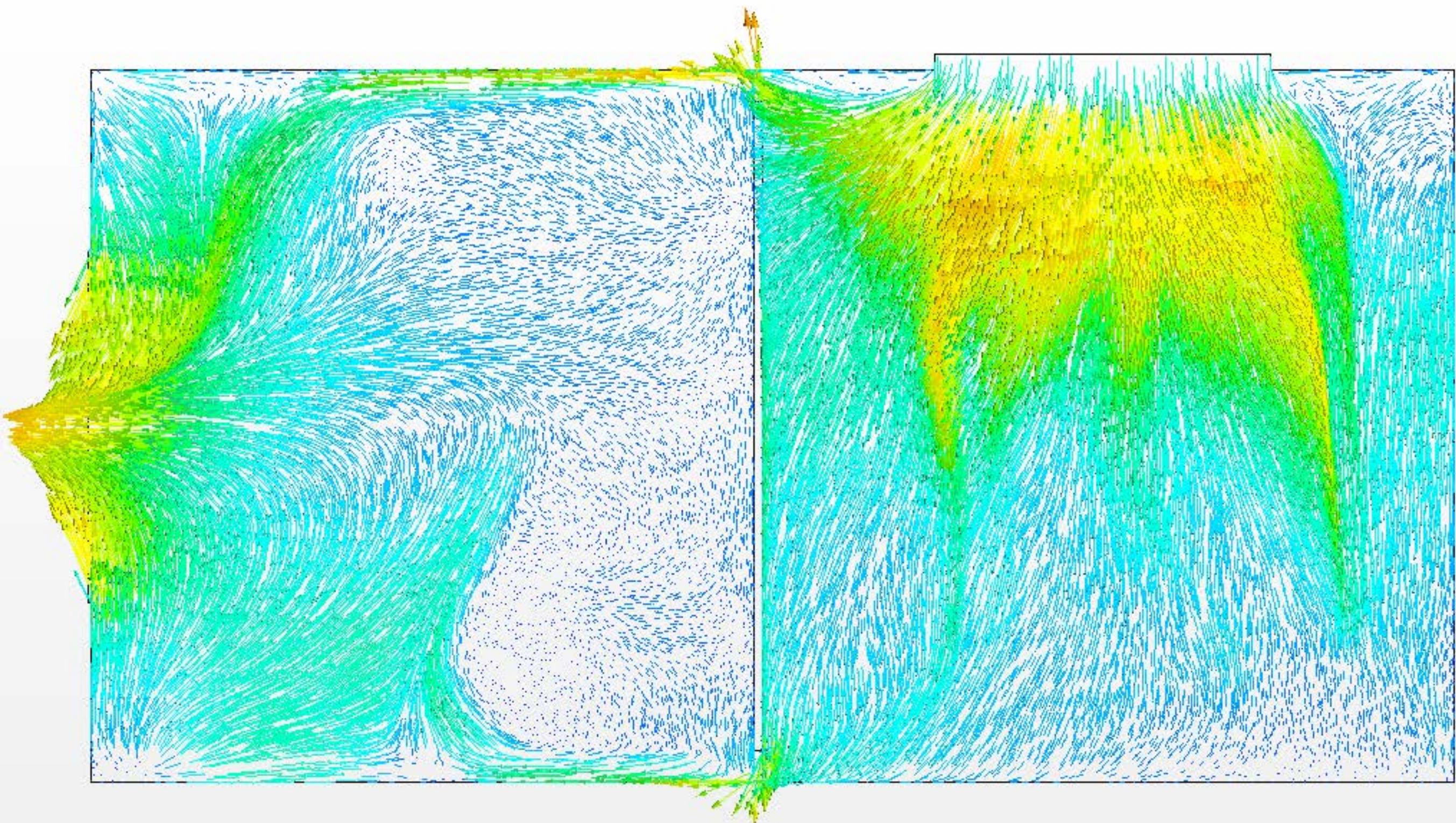

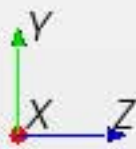
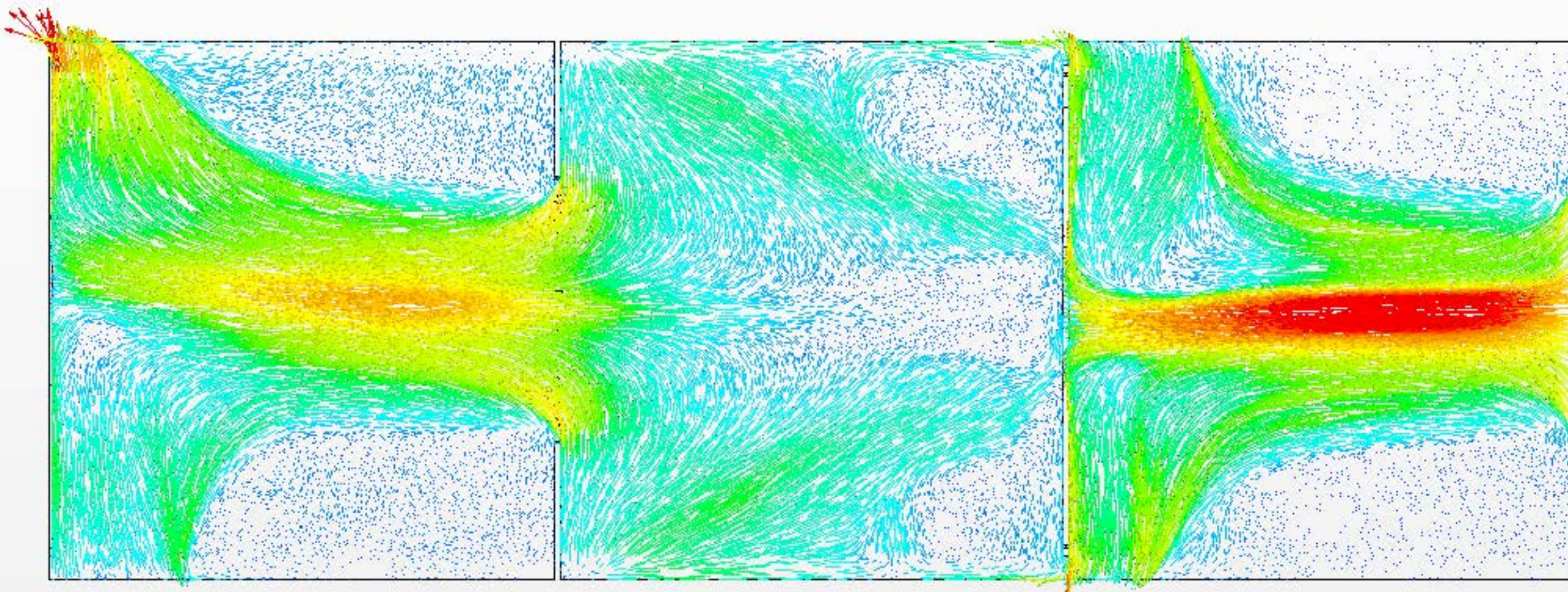

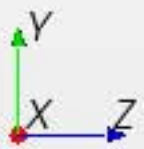
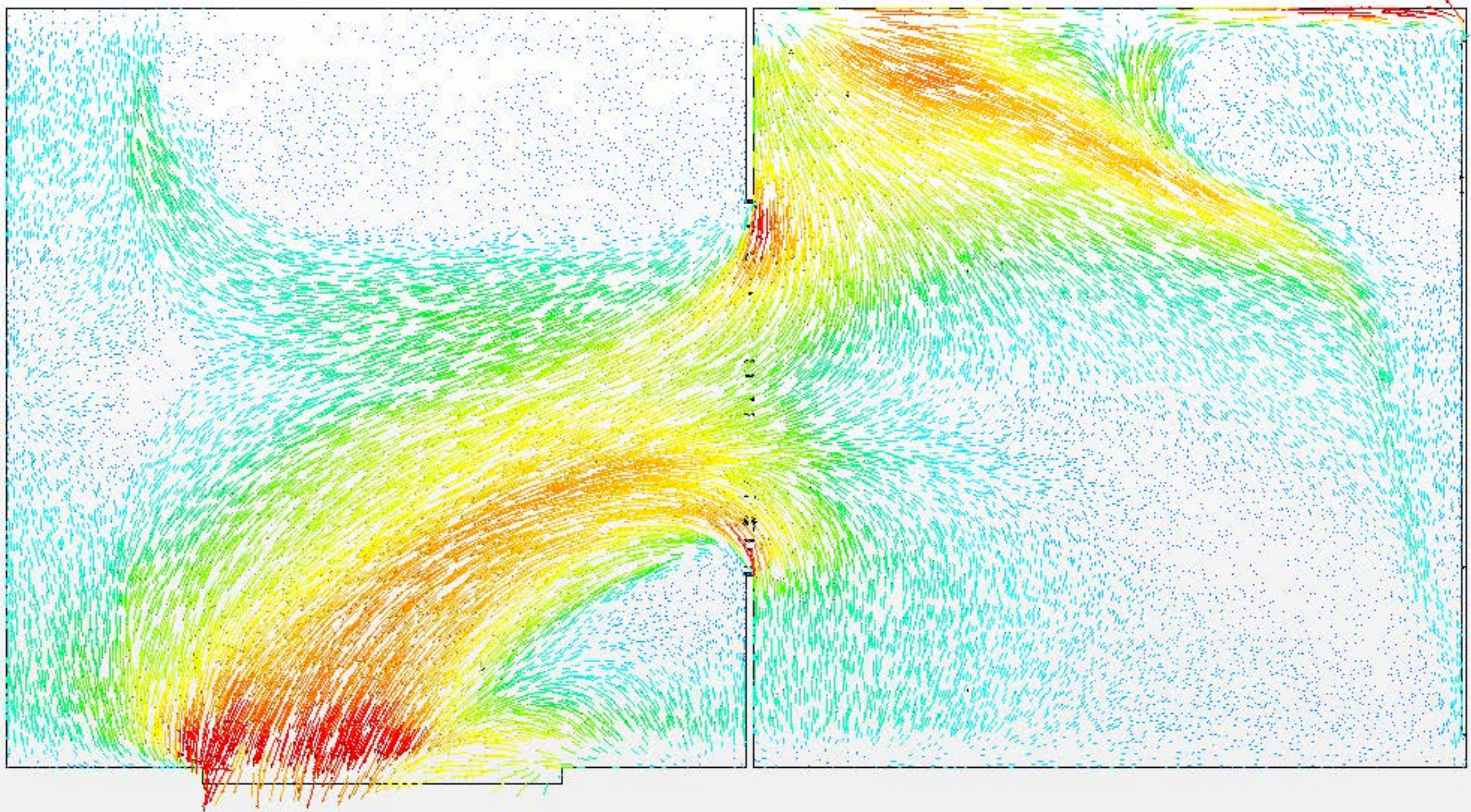

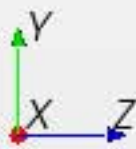
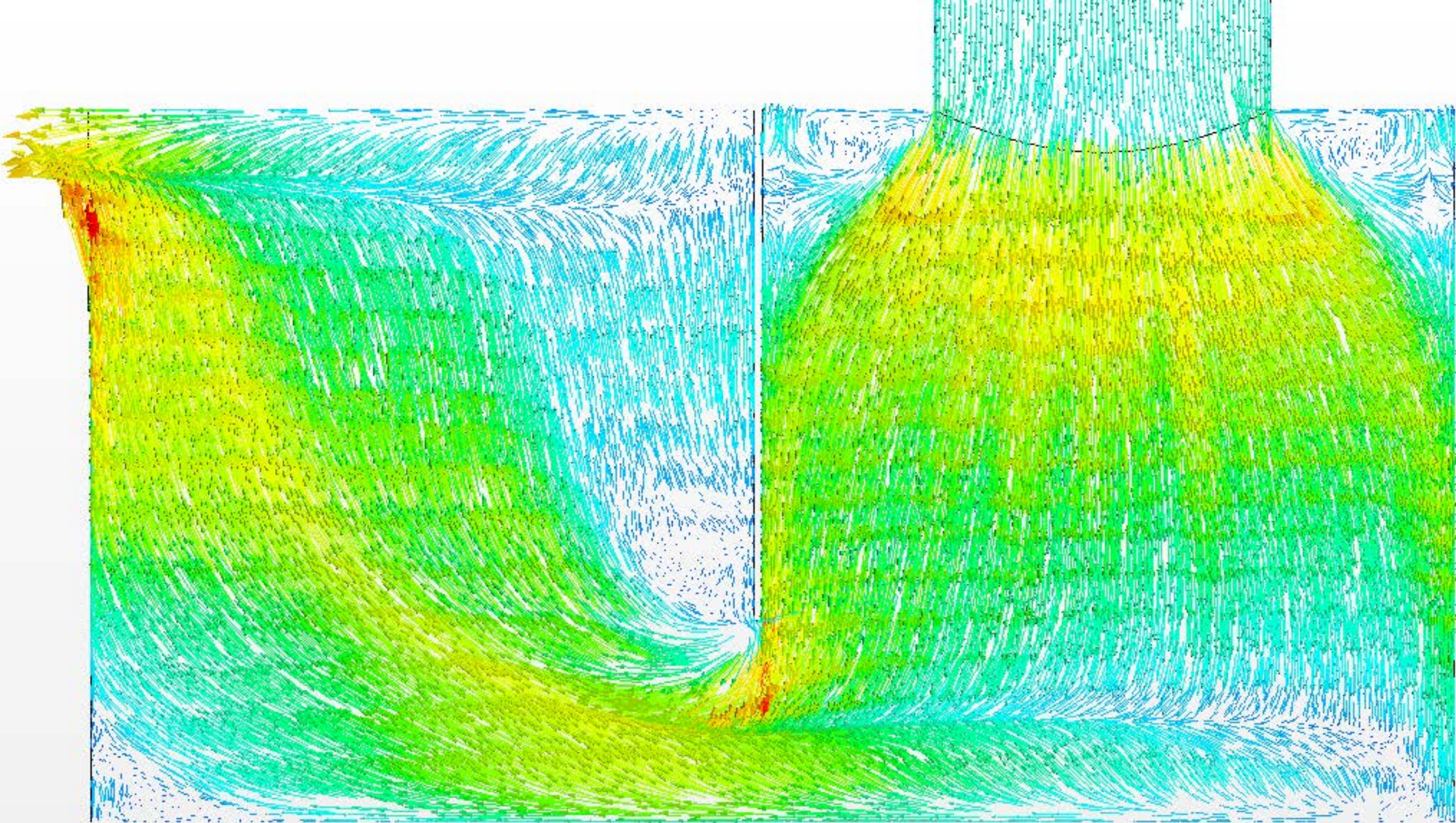

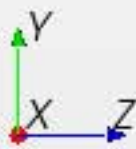
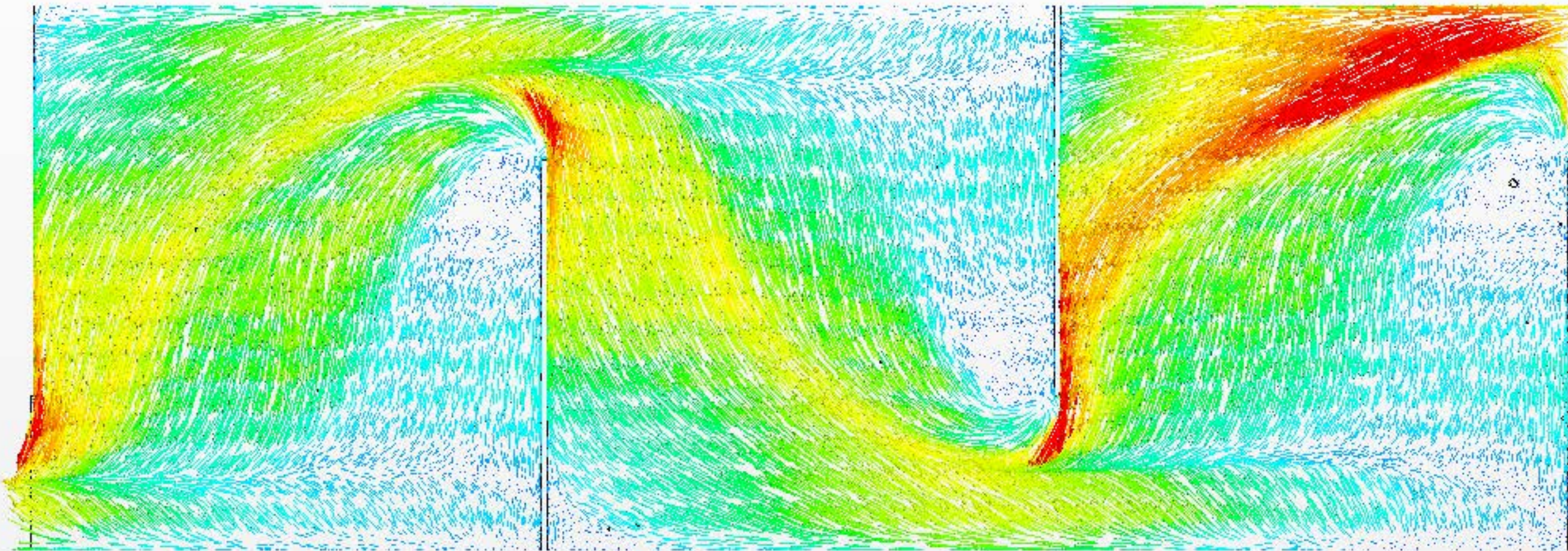

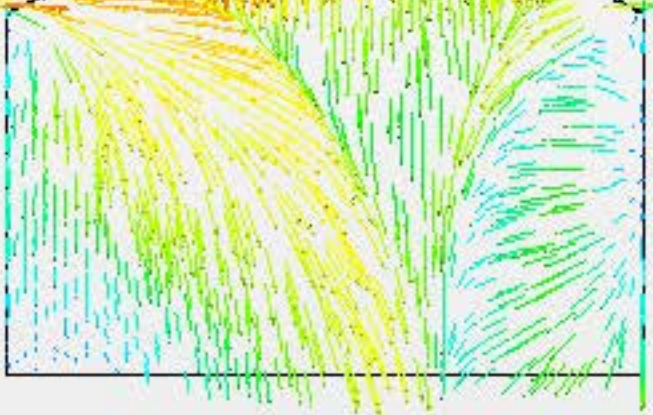
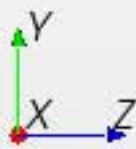
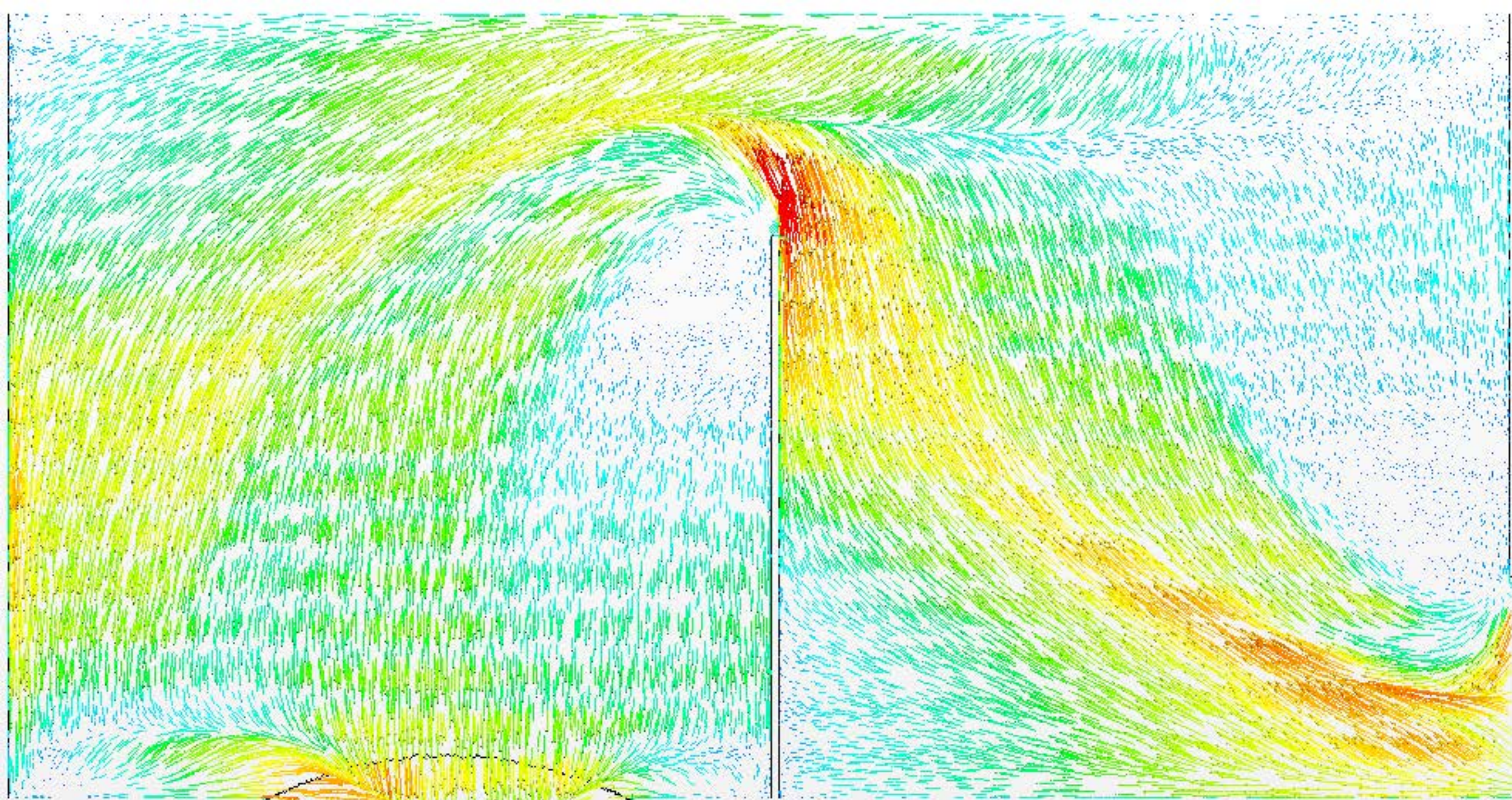

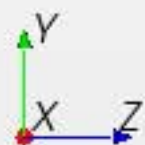
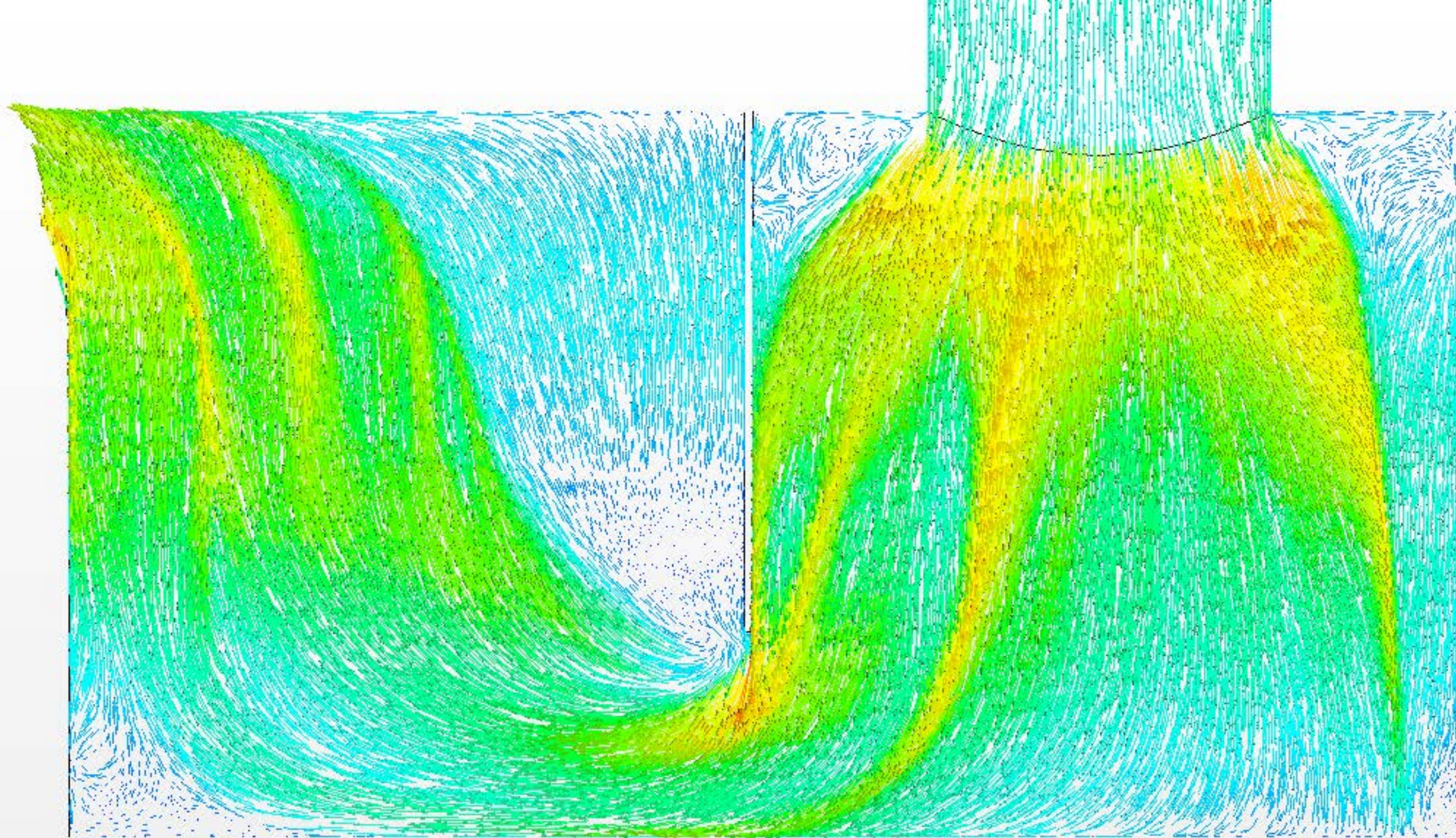

Velocity (m/s)

0.00000	0.60000	1.2000	1.8000	2.4000	3.0000
---------	---------	--------	--------	--------	--------



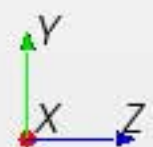
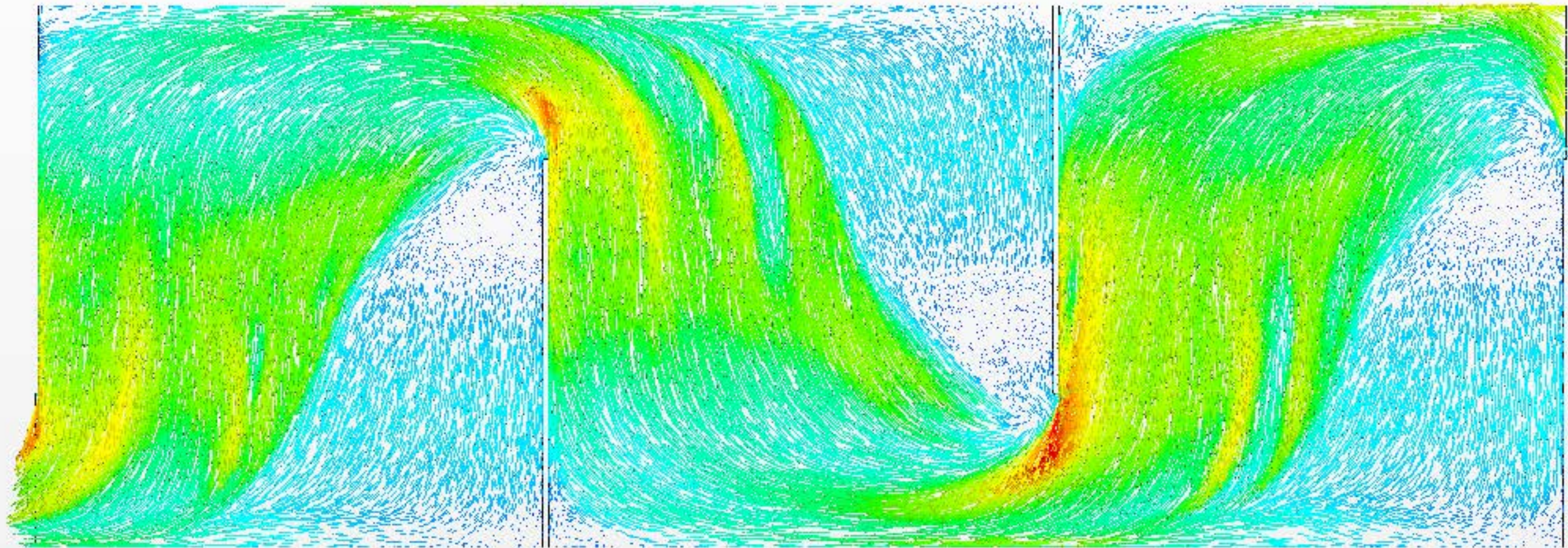

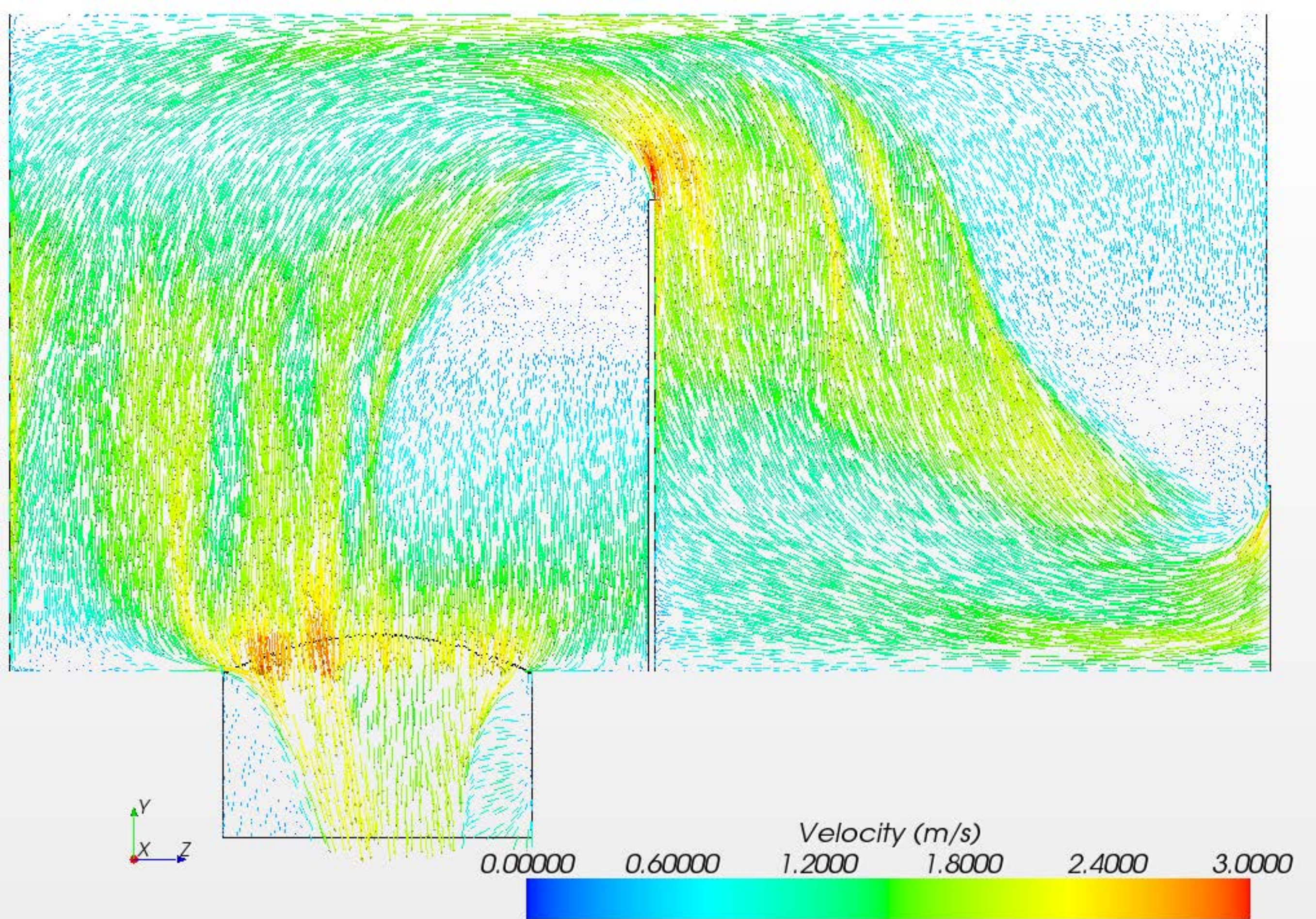

Velocity (m/s)

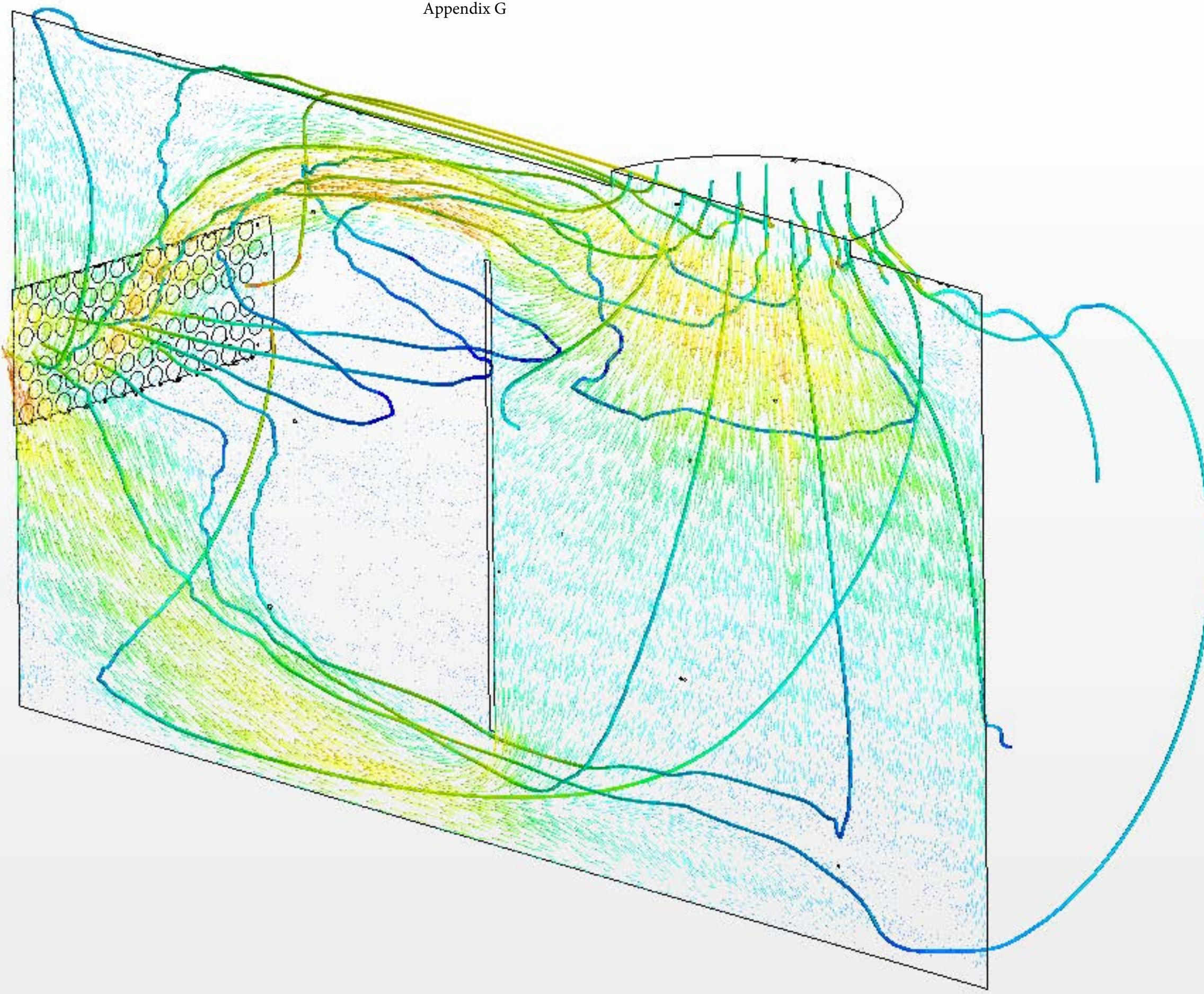

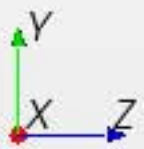
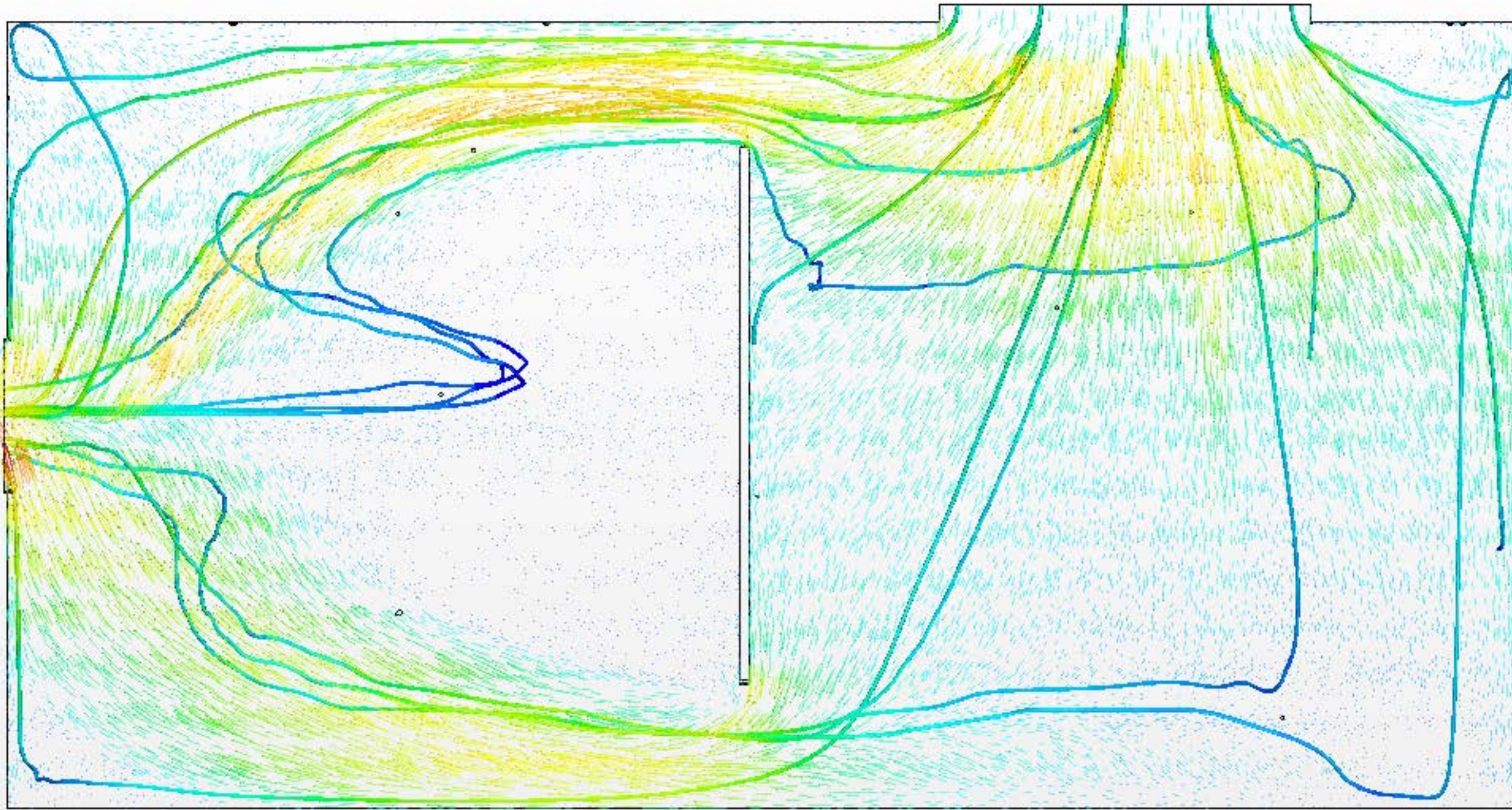

Velocity (m/s)

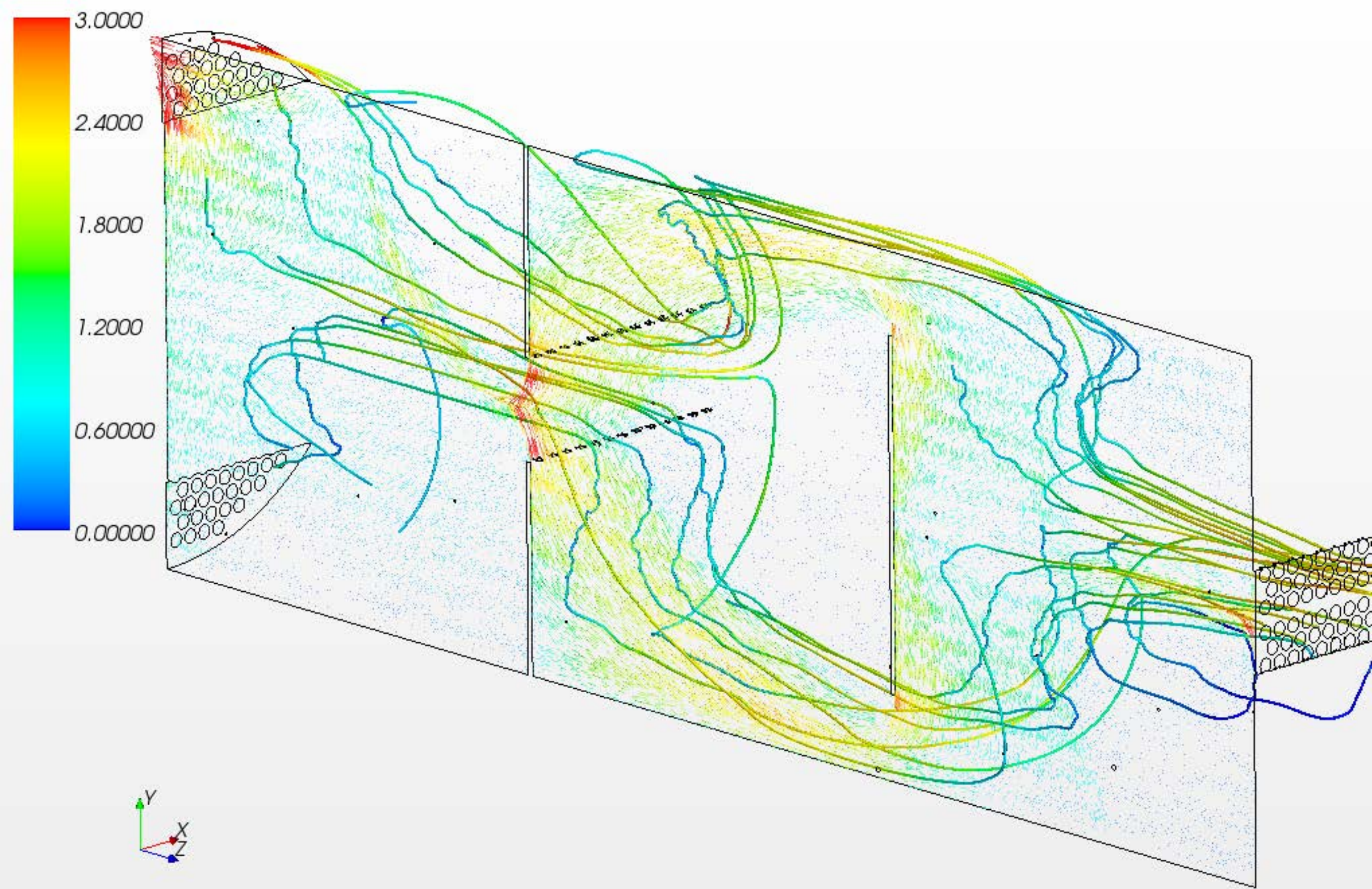

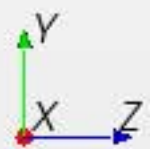
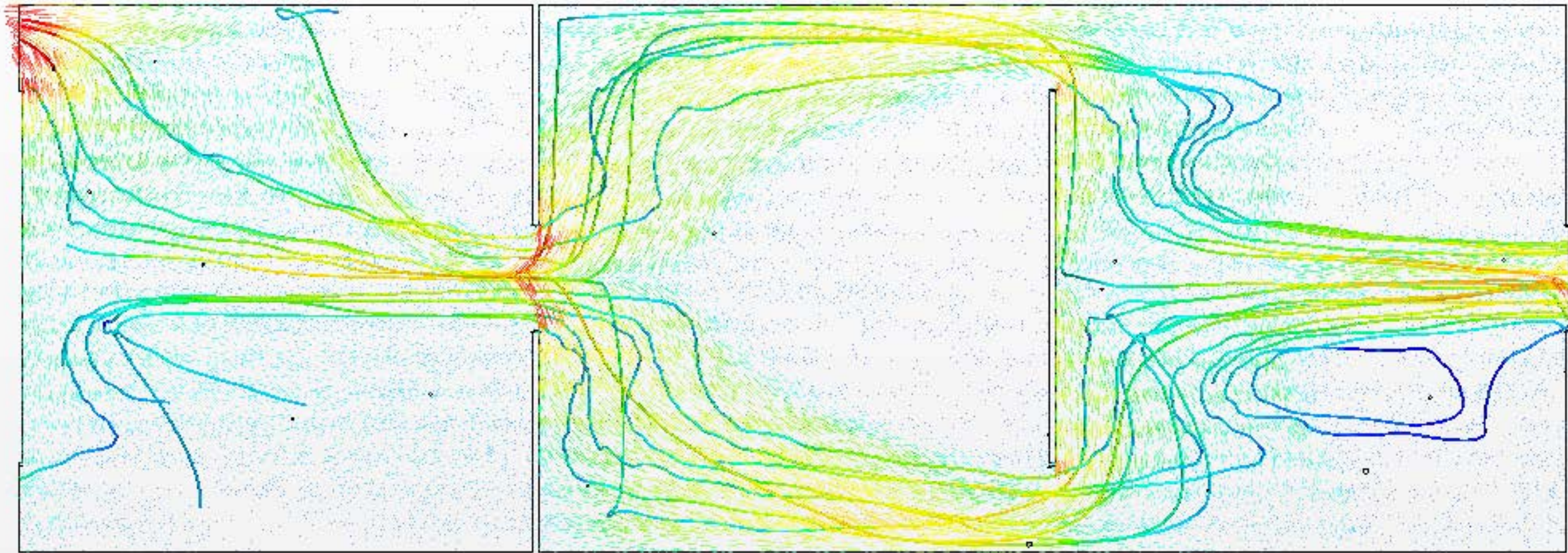

Velocity (m/s)

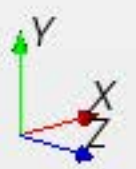
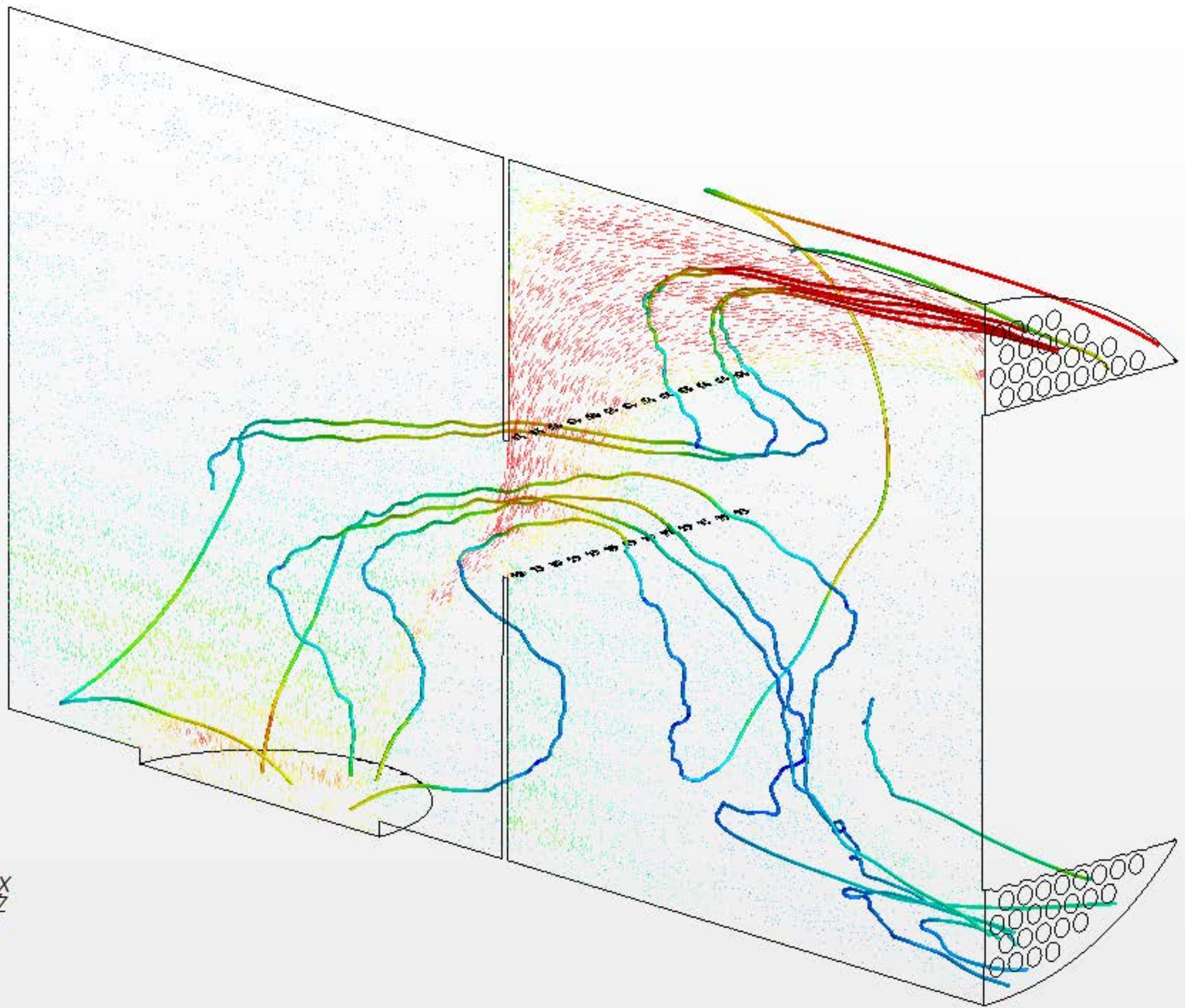

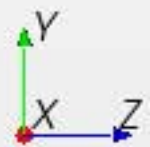
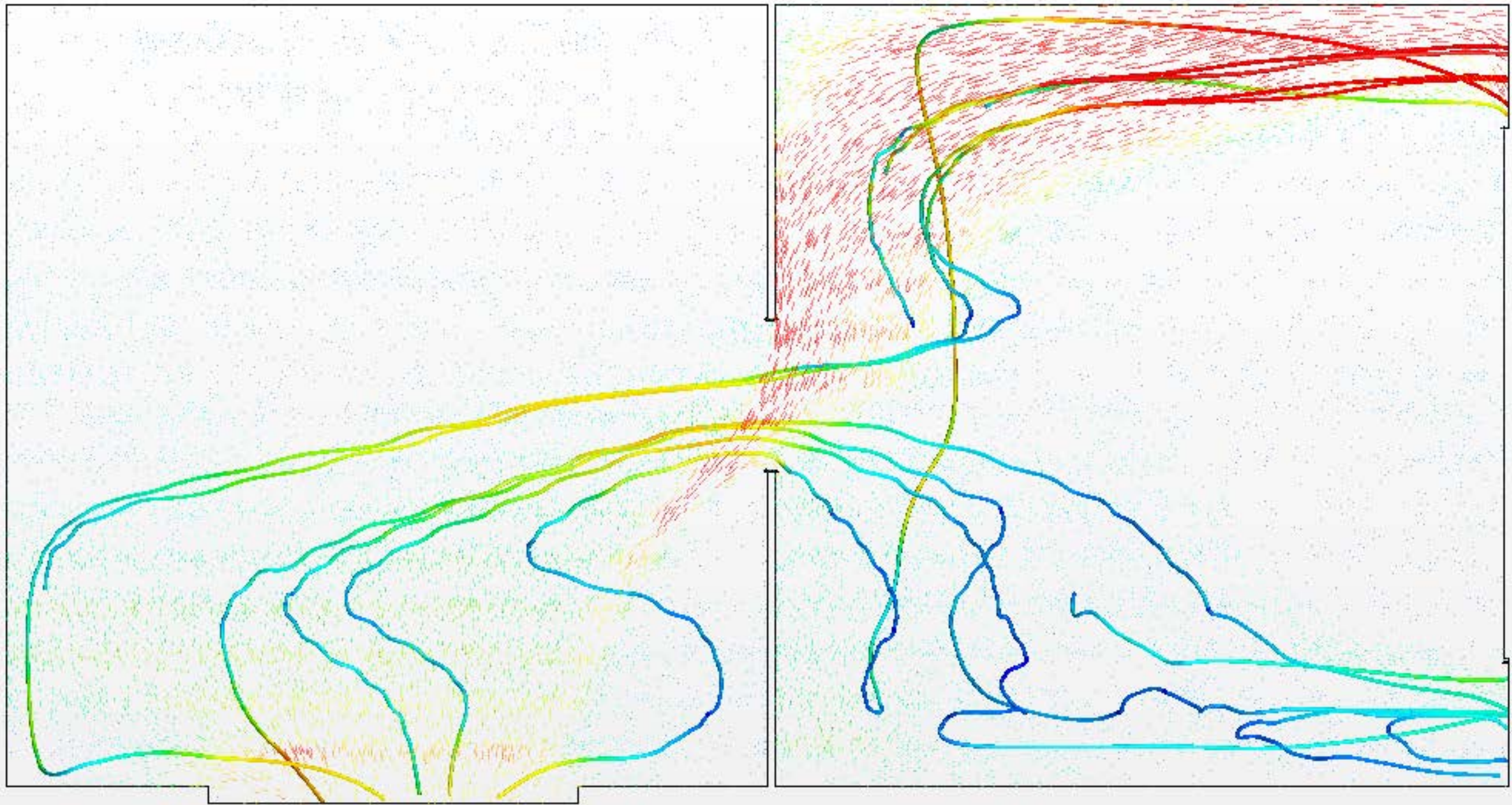

Velocity (m/s)

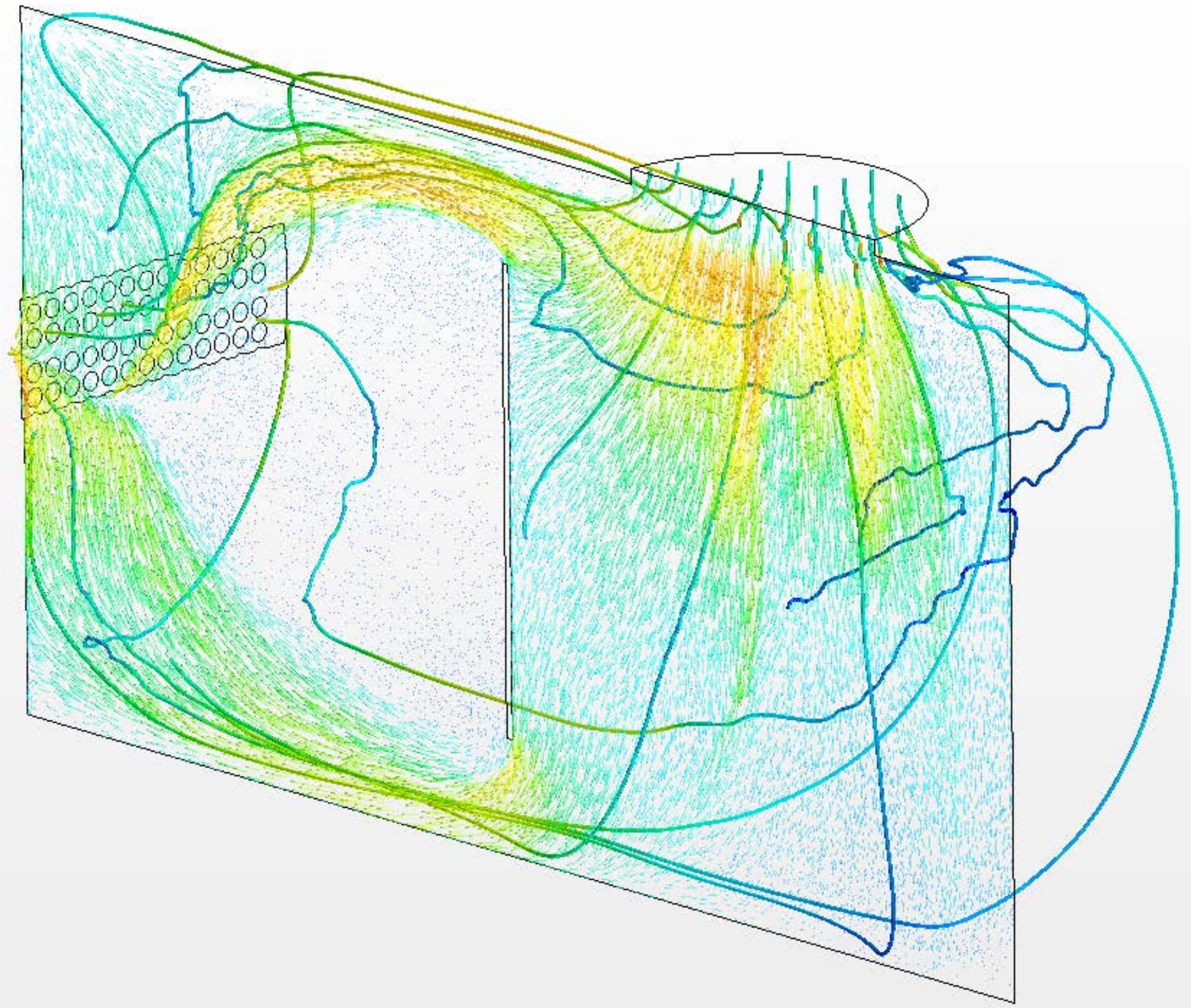

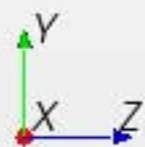
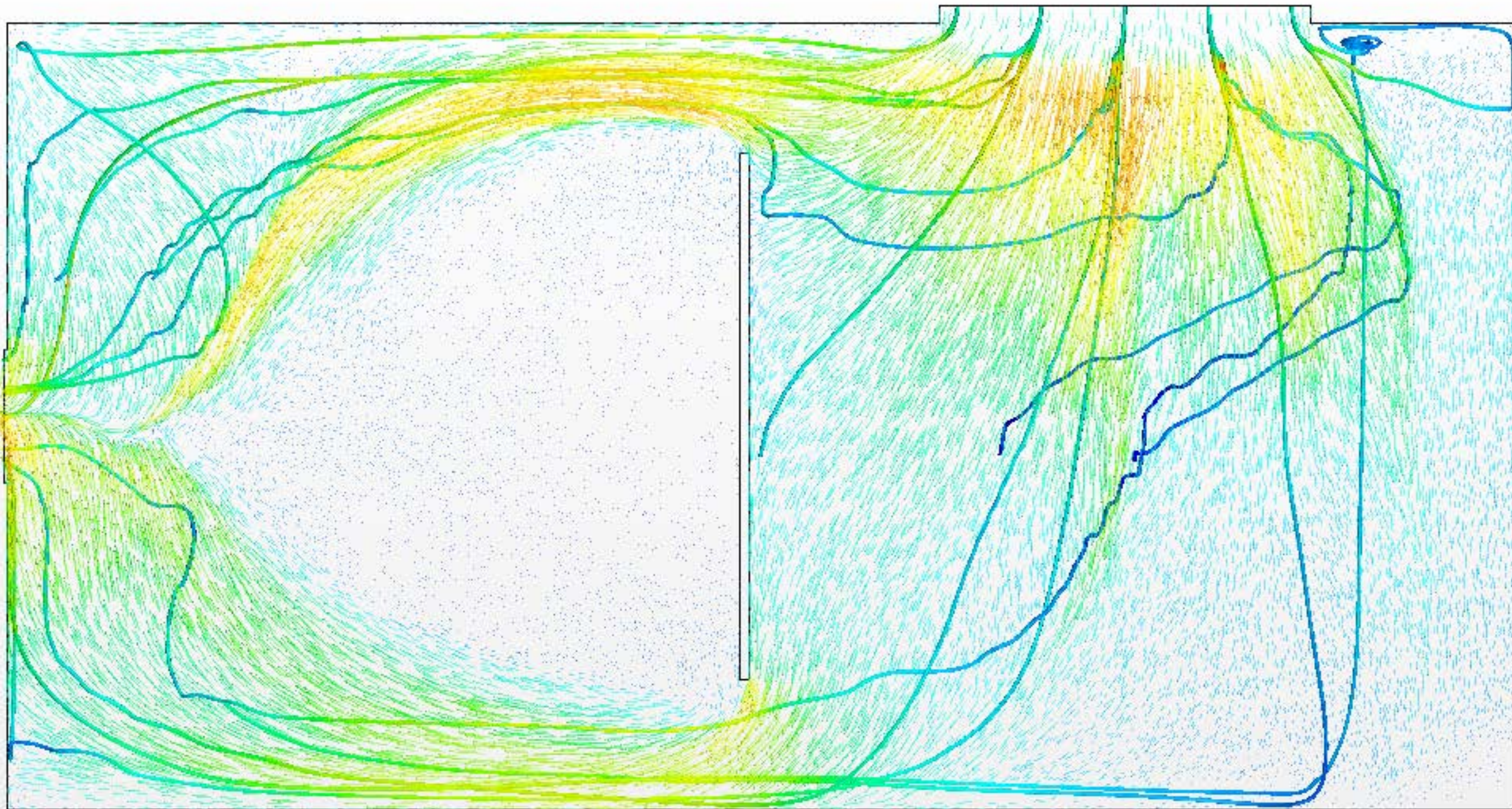

Velocity (m/s)

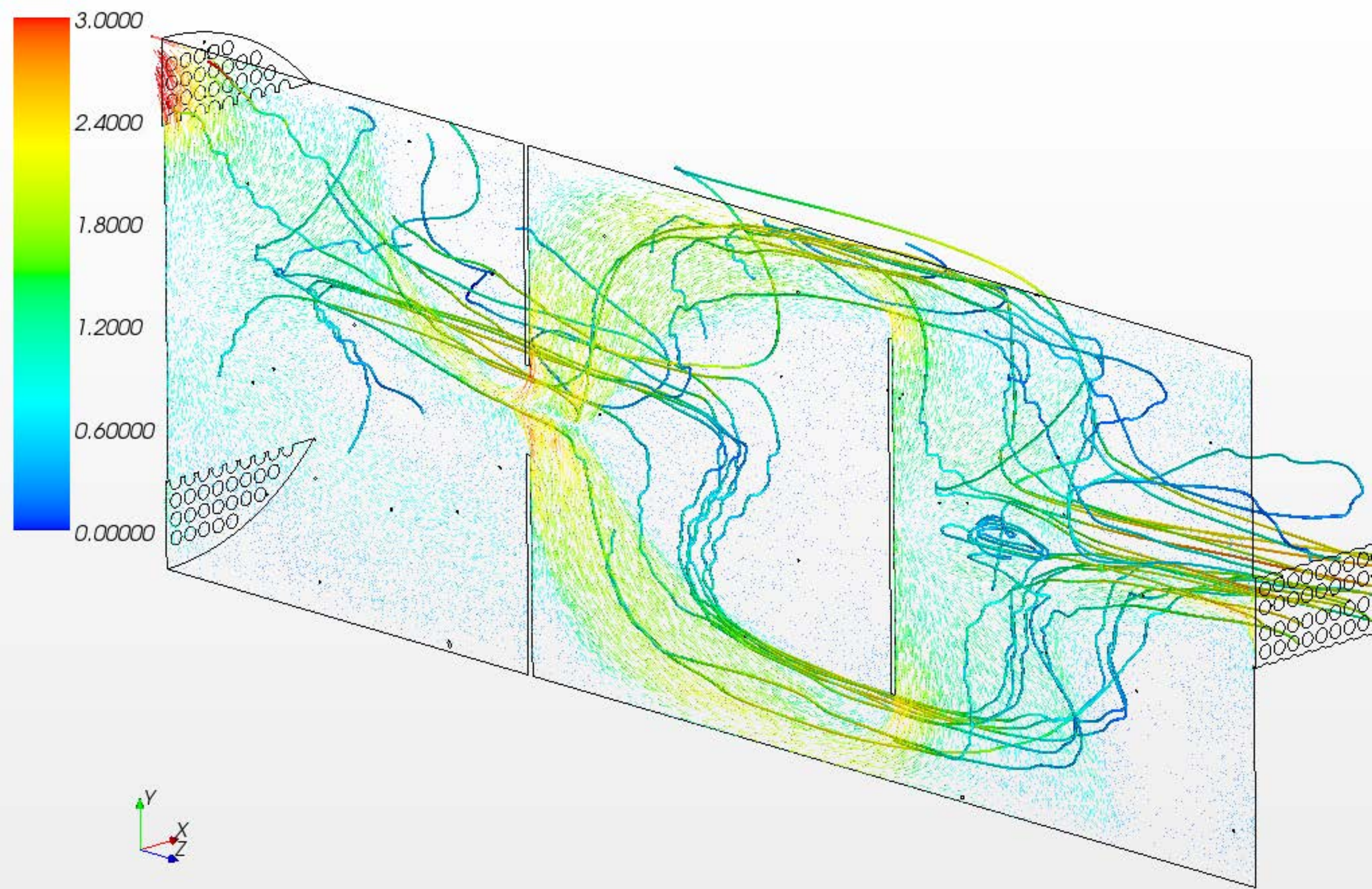

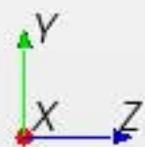
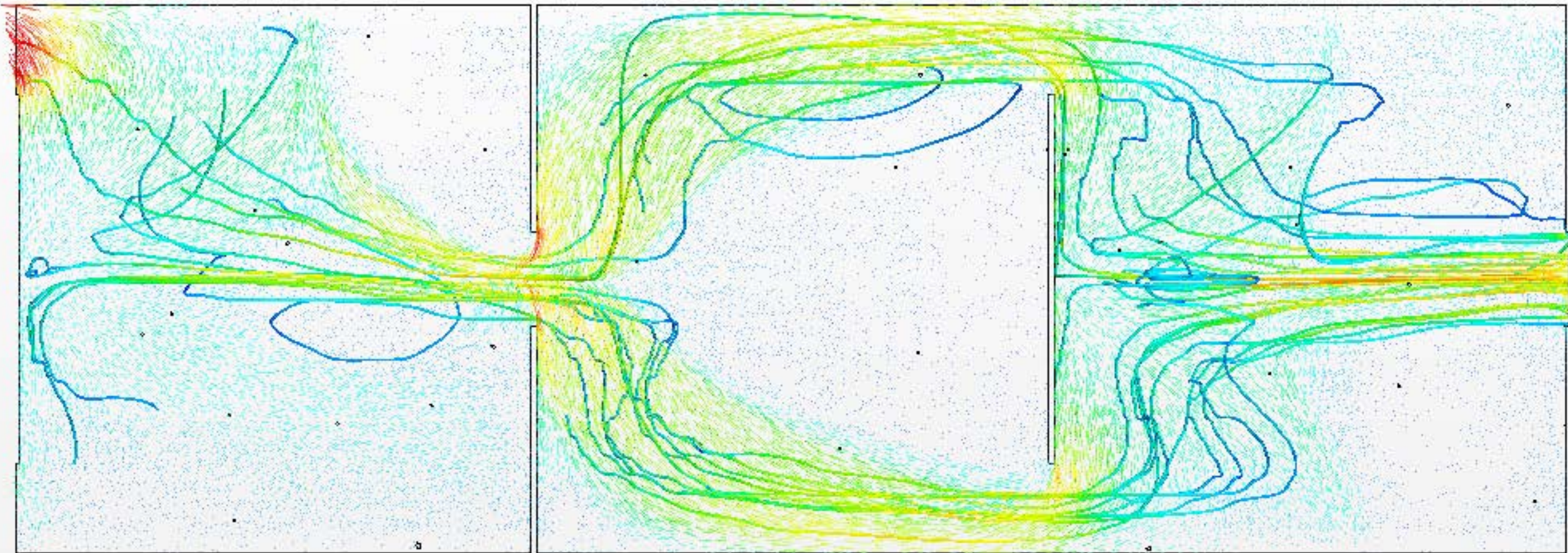

Velocity (m/s)

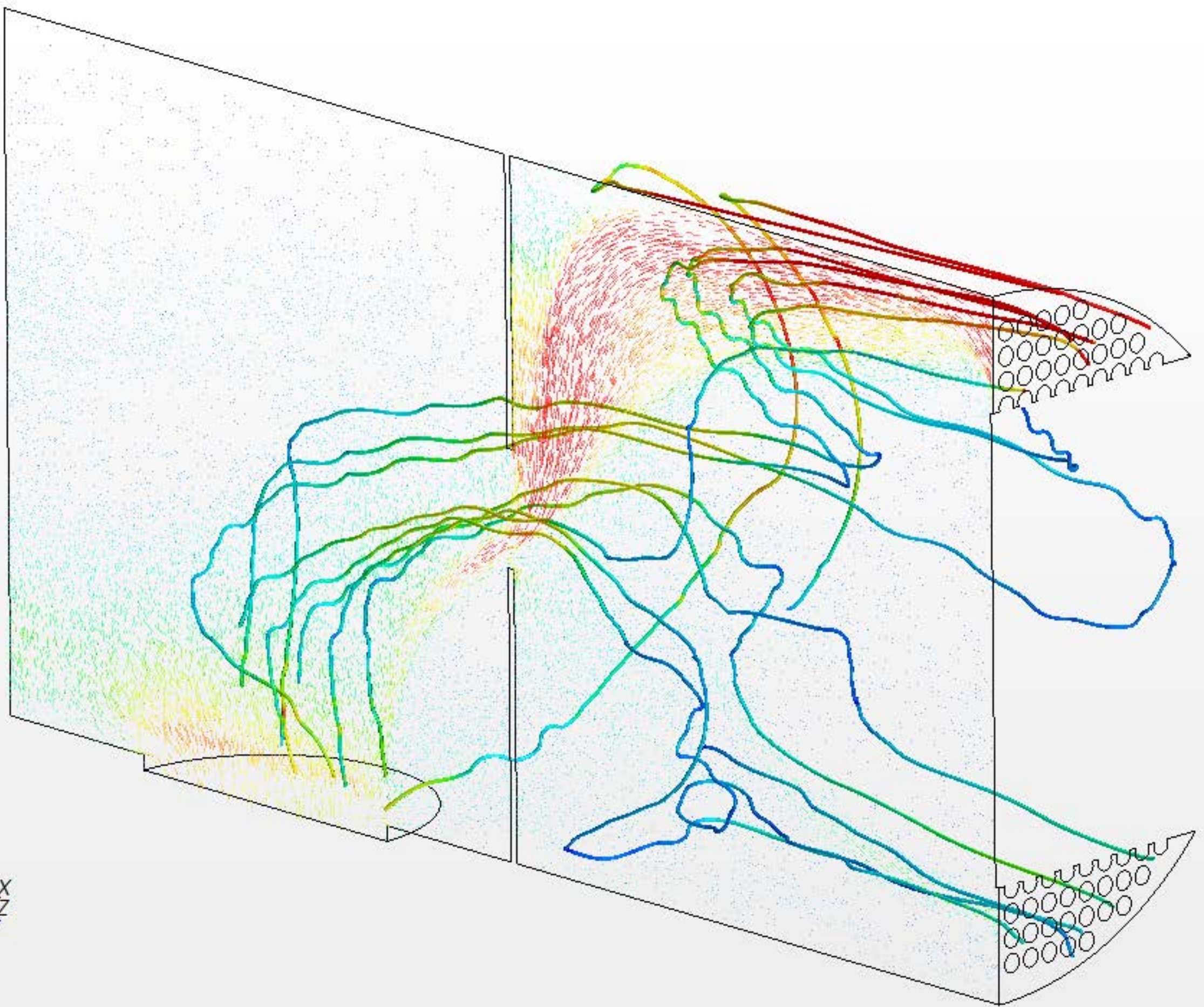

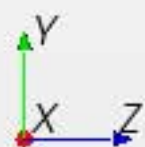
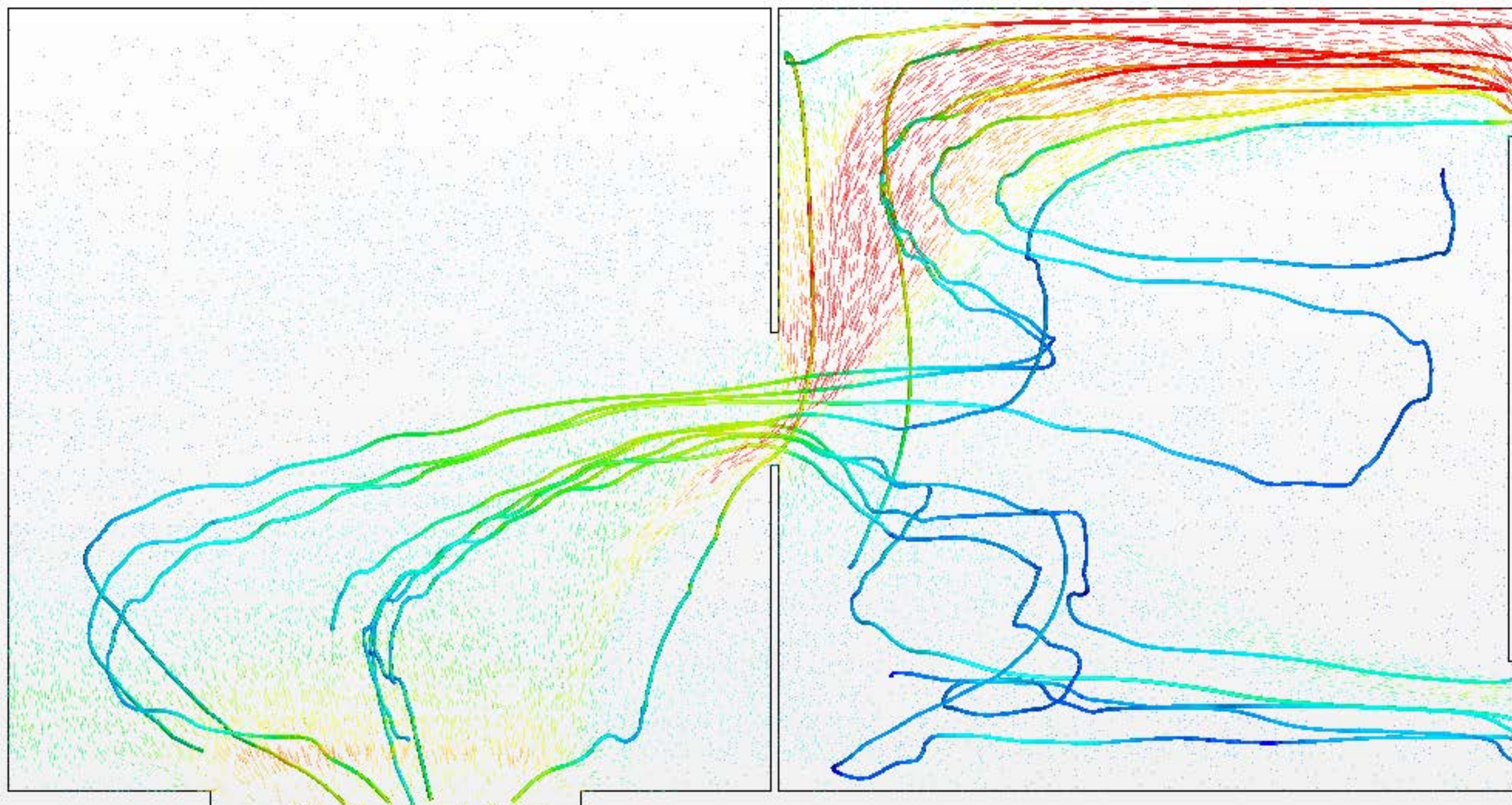

Velocity (m/s)

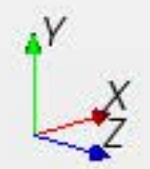
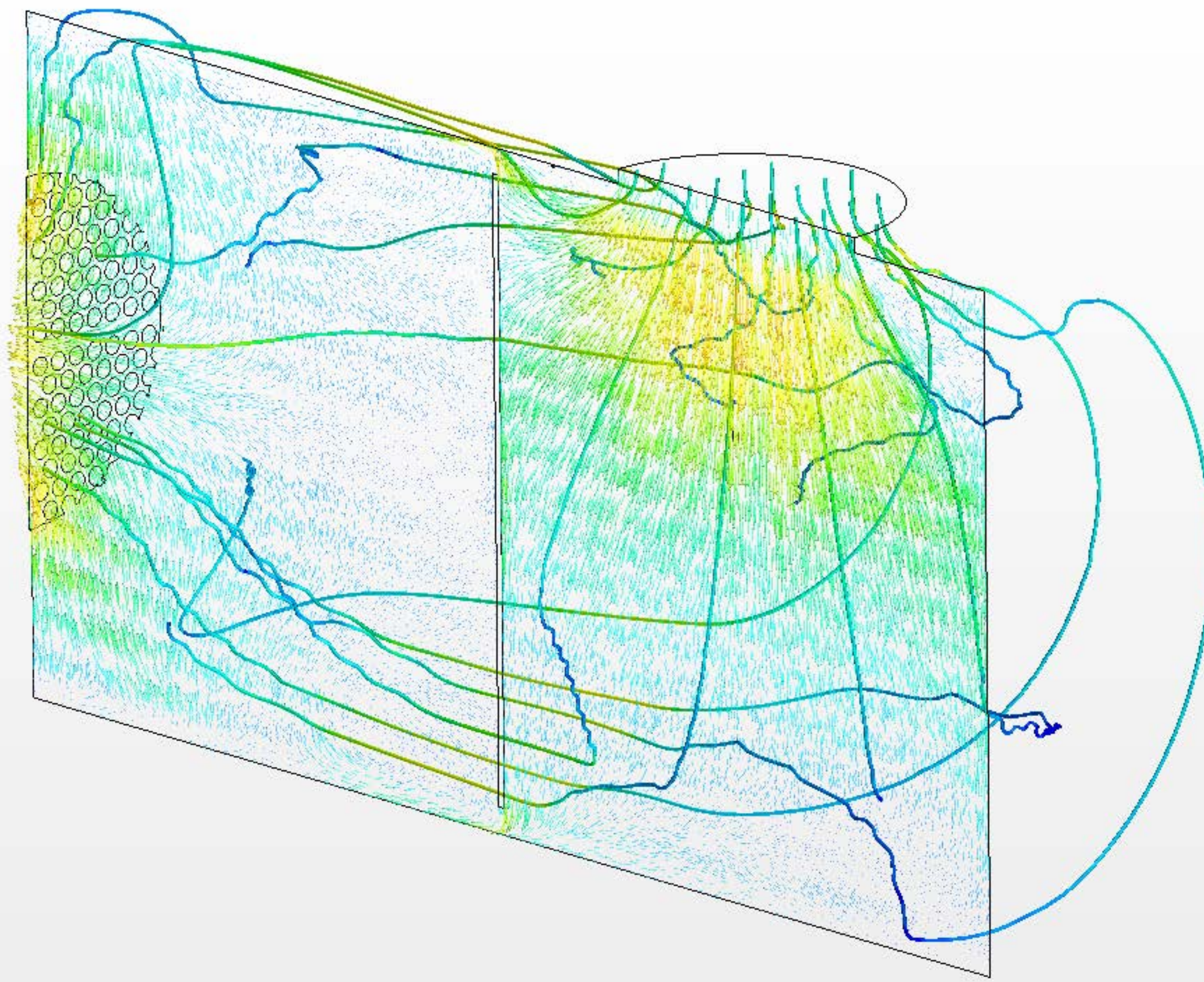

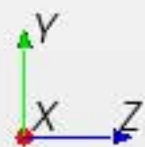
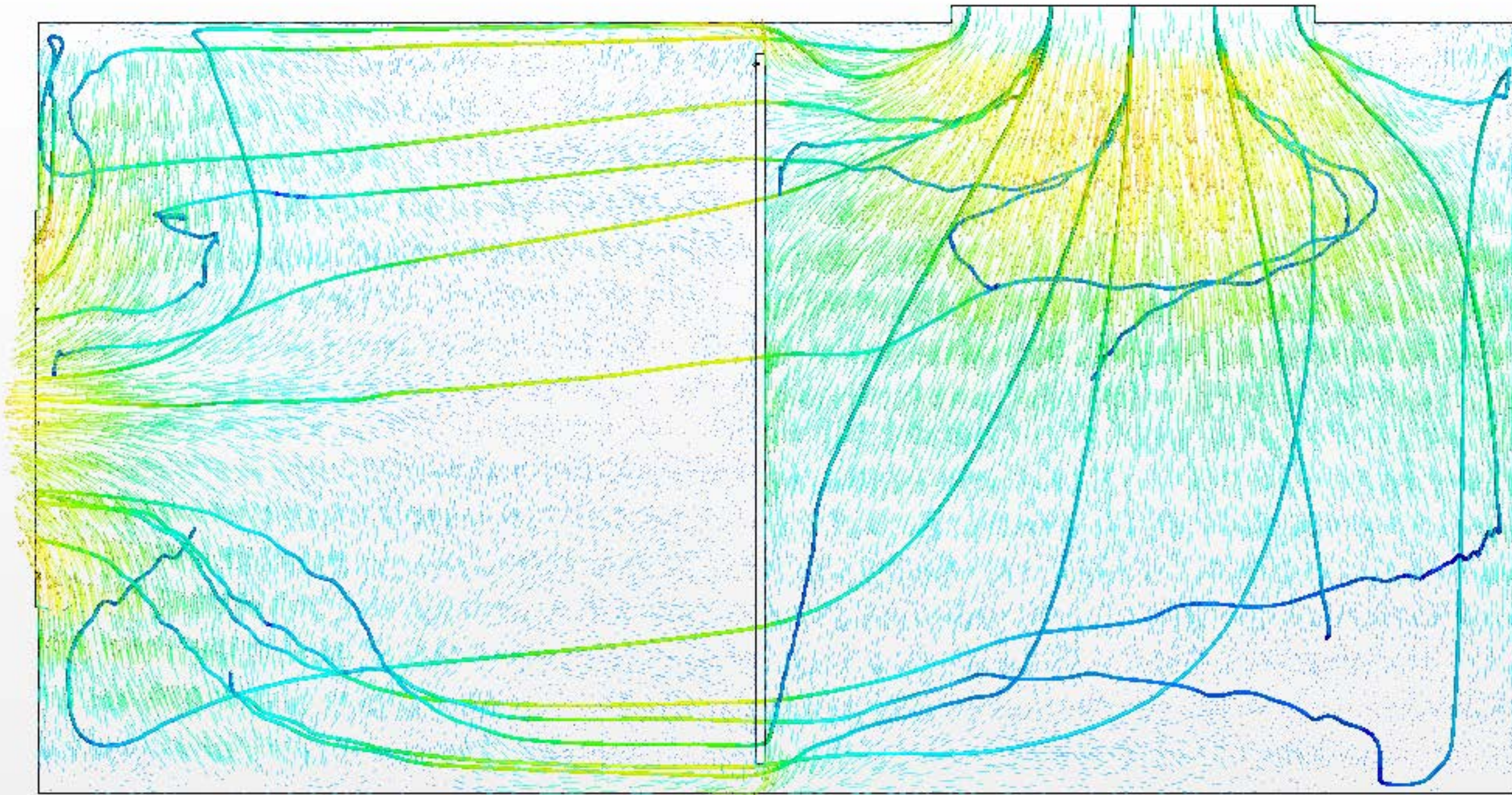

Velocity (m/s)

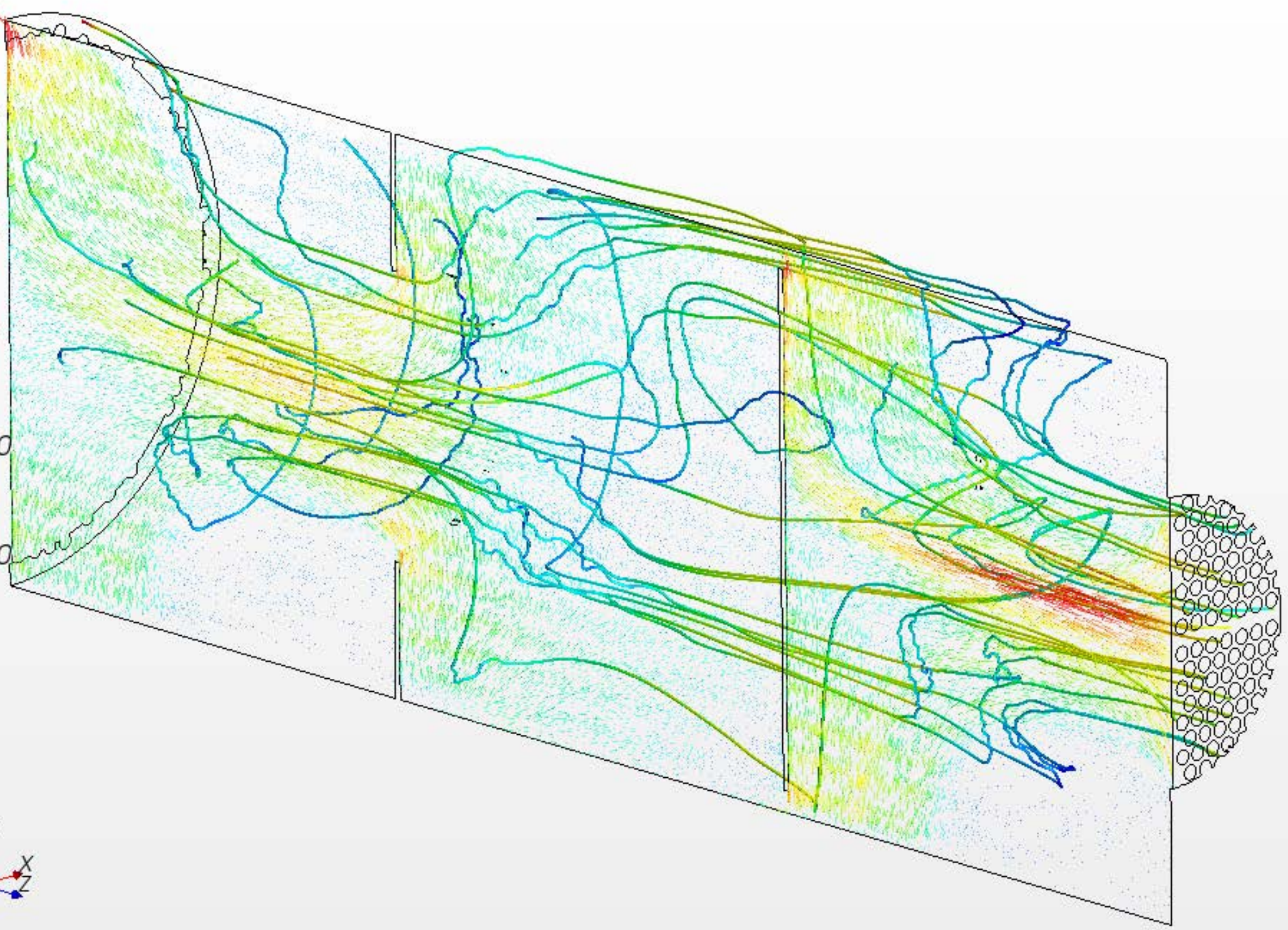
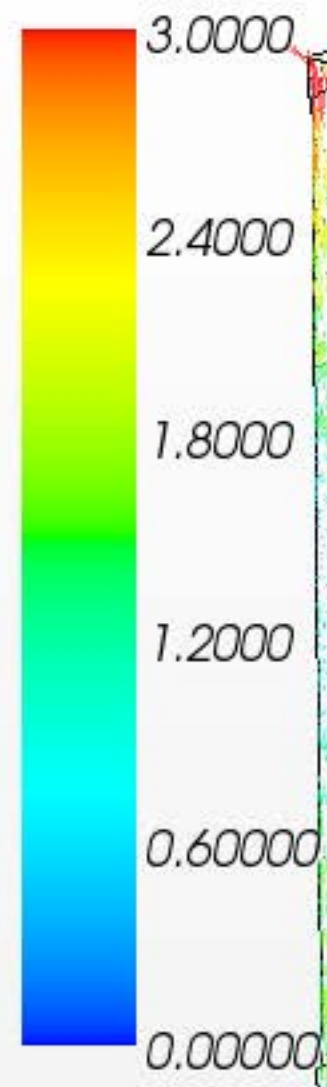

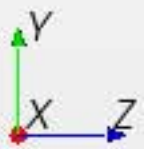
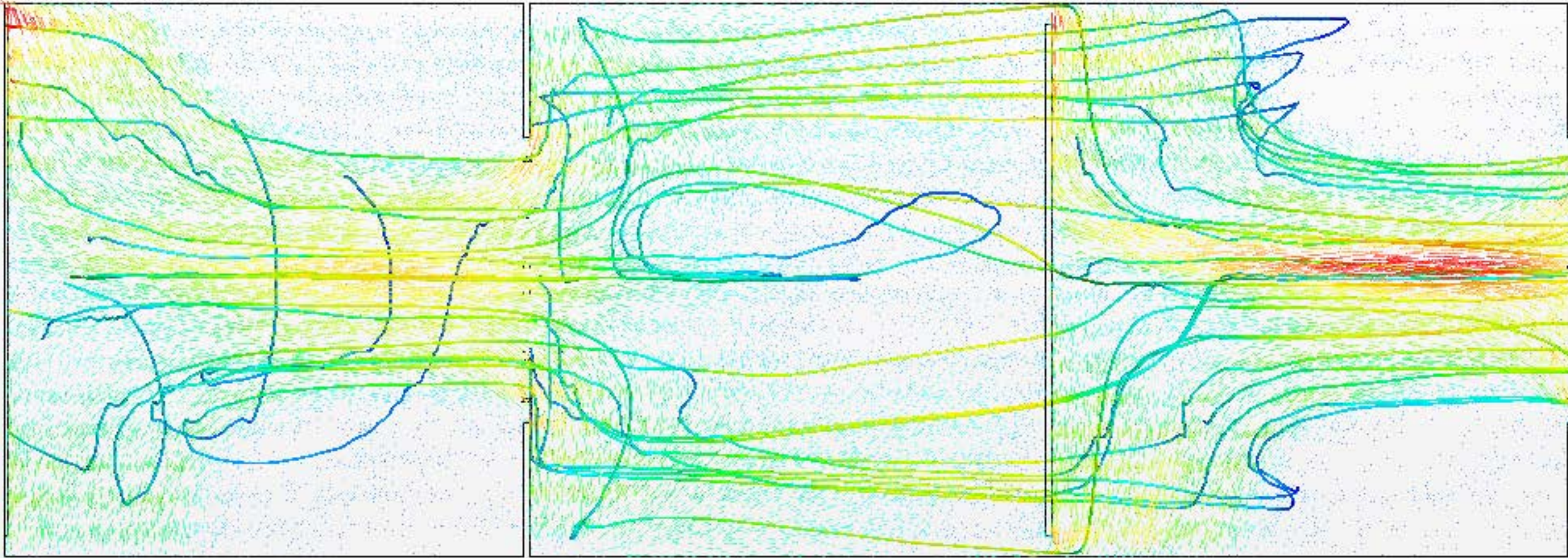

Velocity (m/s)

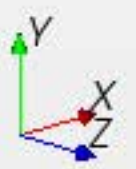
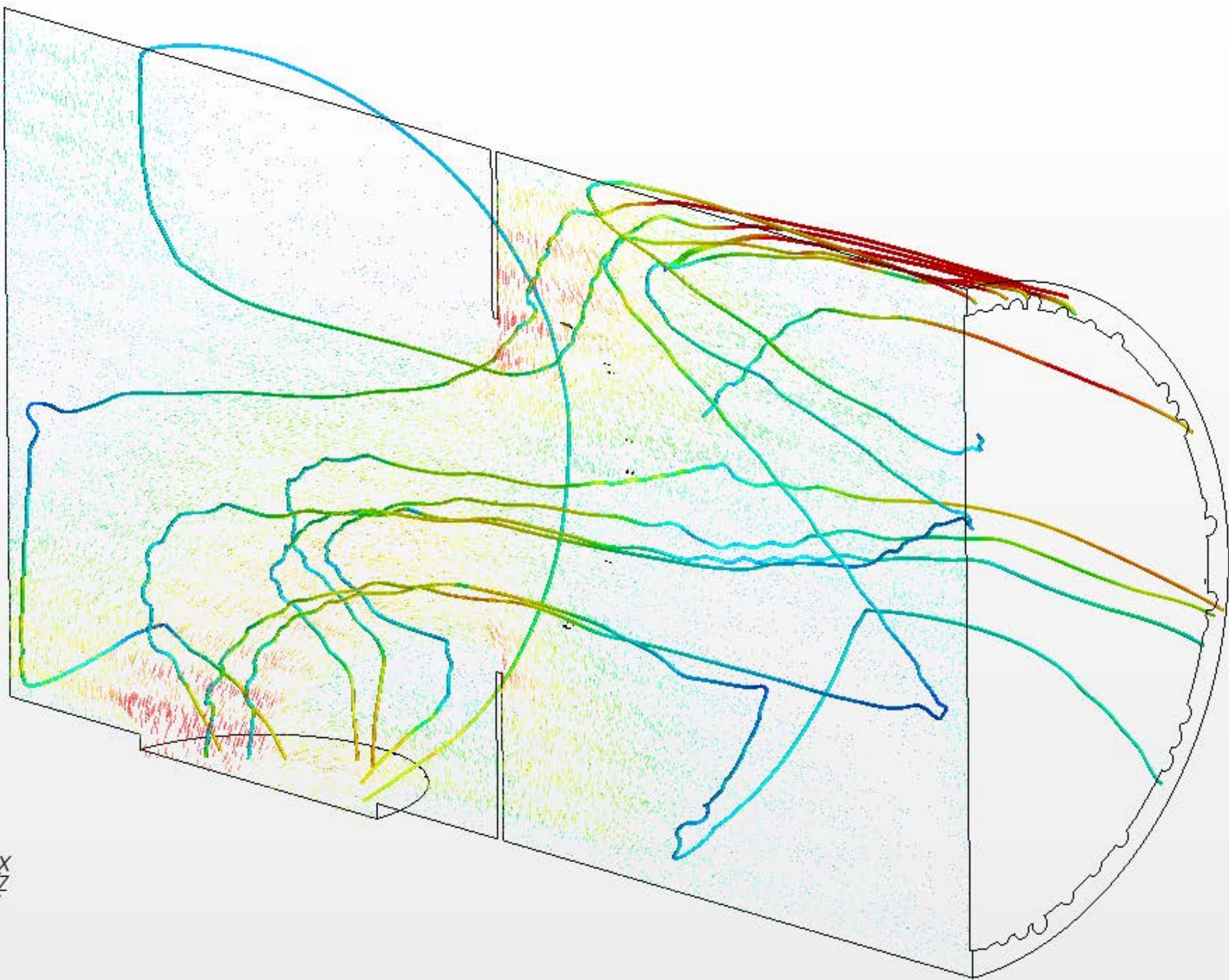

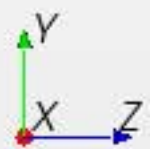
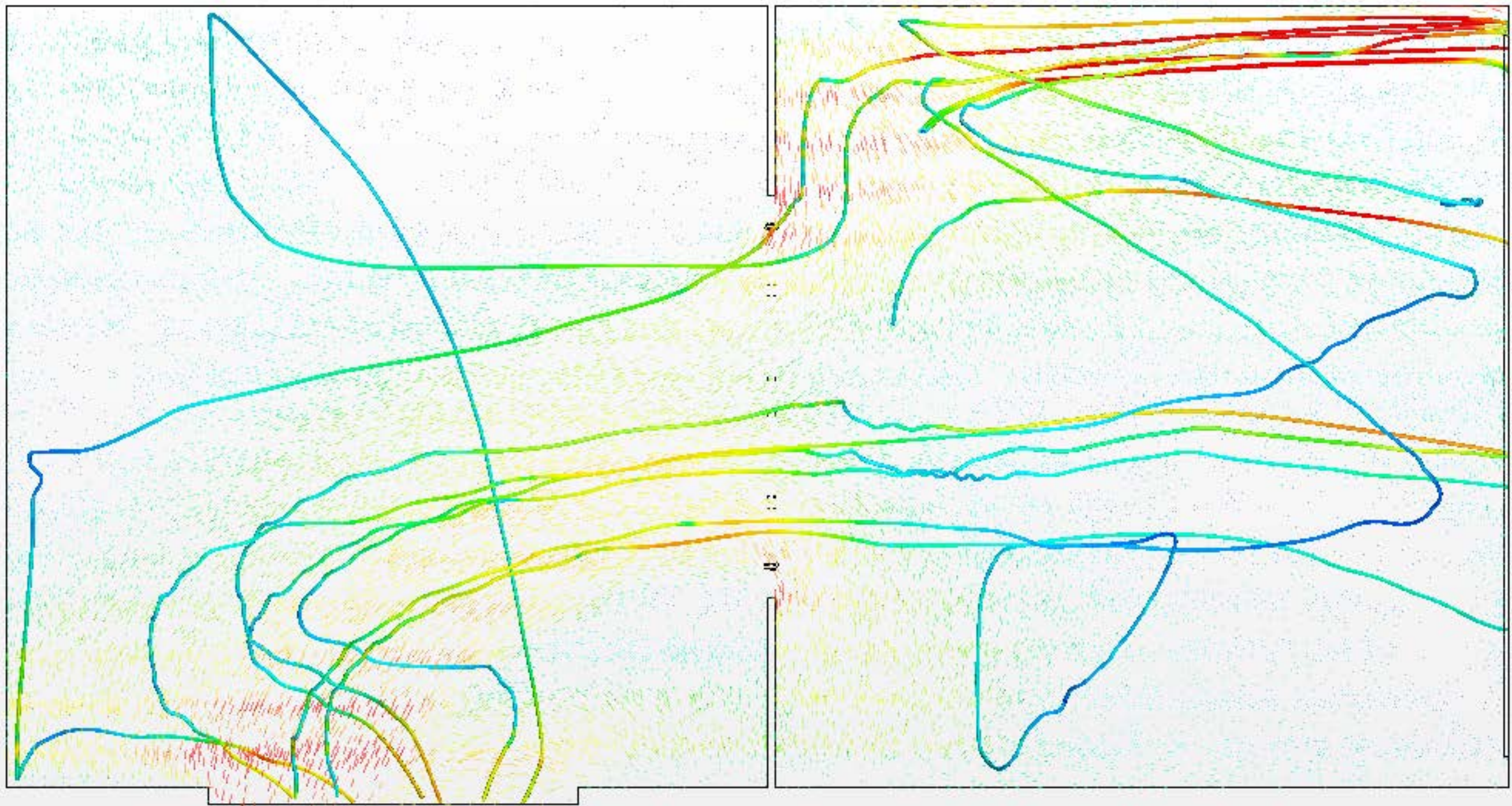

Velocity (m/s)

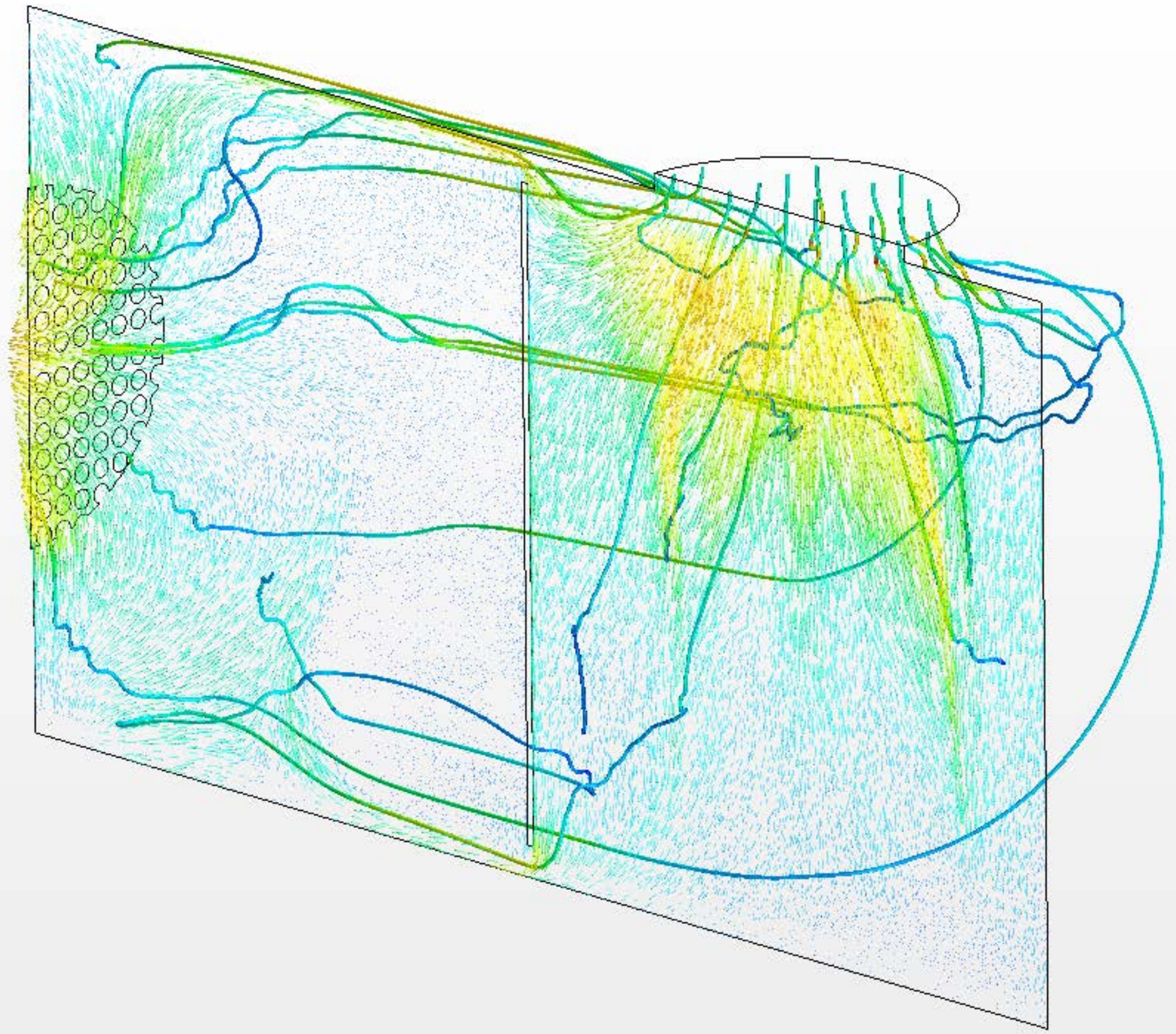

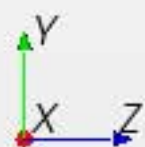
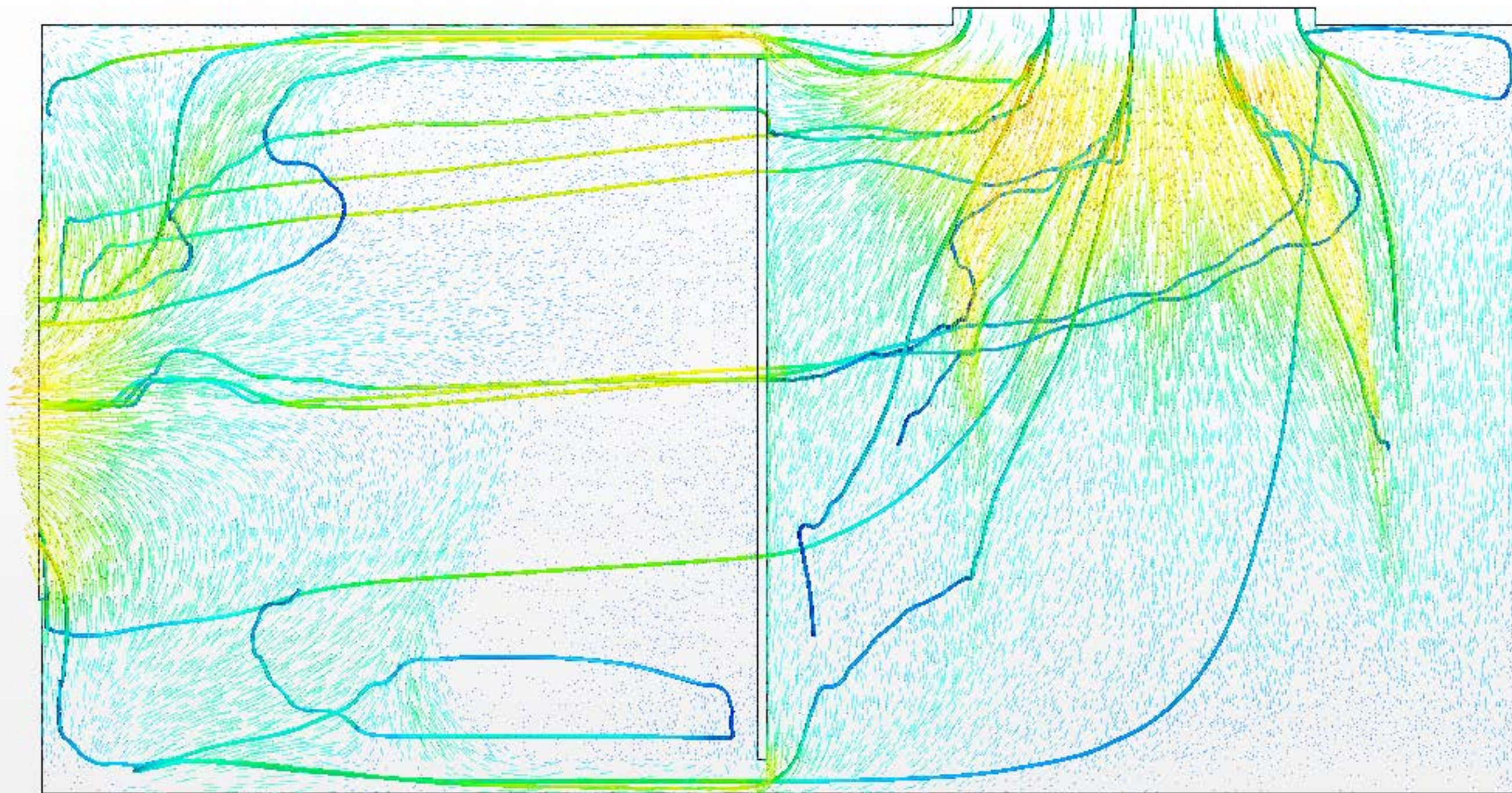

Velocity (m/s)

0.00000 0.60000 1.2000 1.8000 2.4000 3.0000



Velocity (m/s)

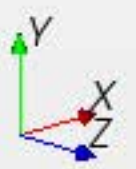
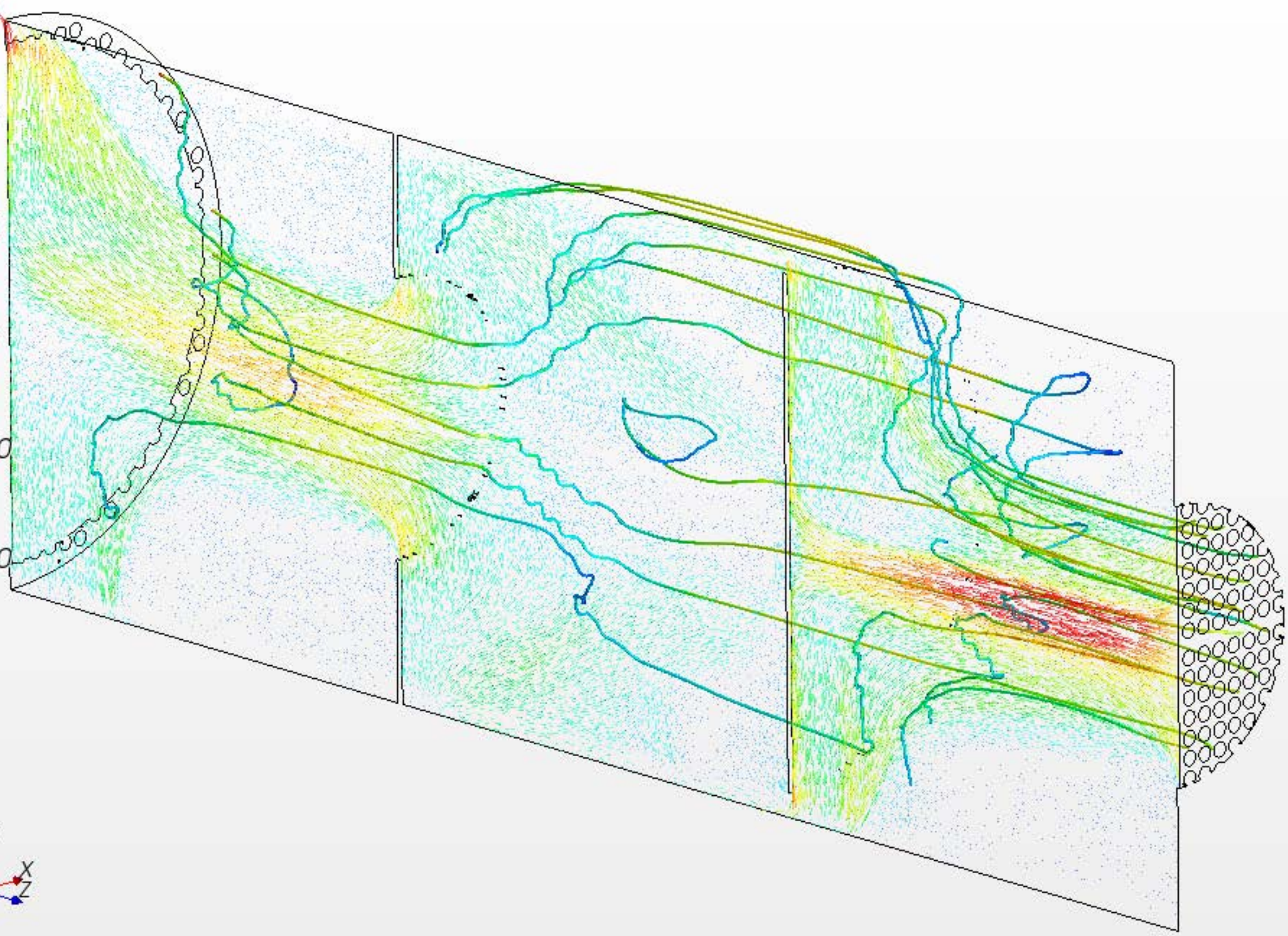
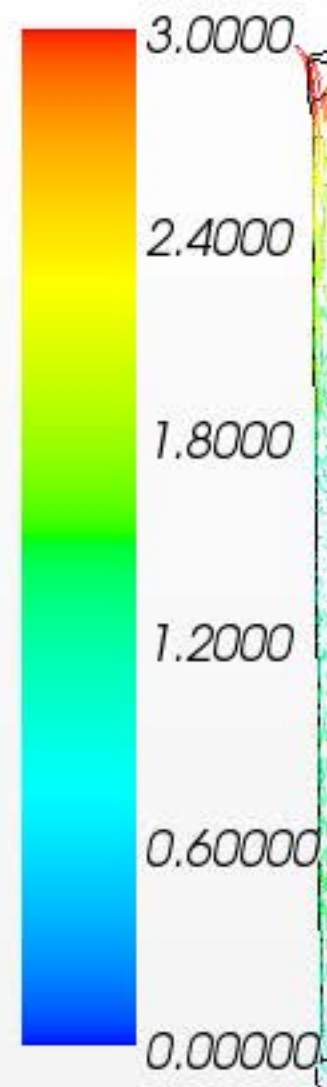

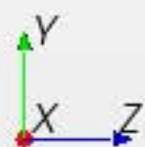
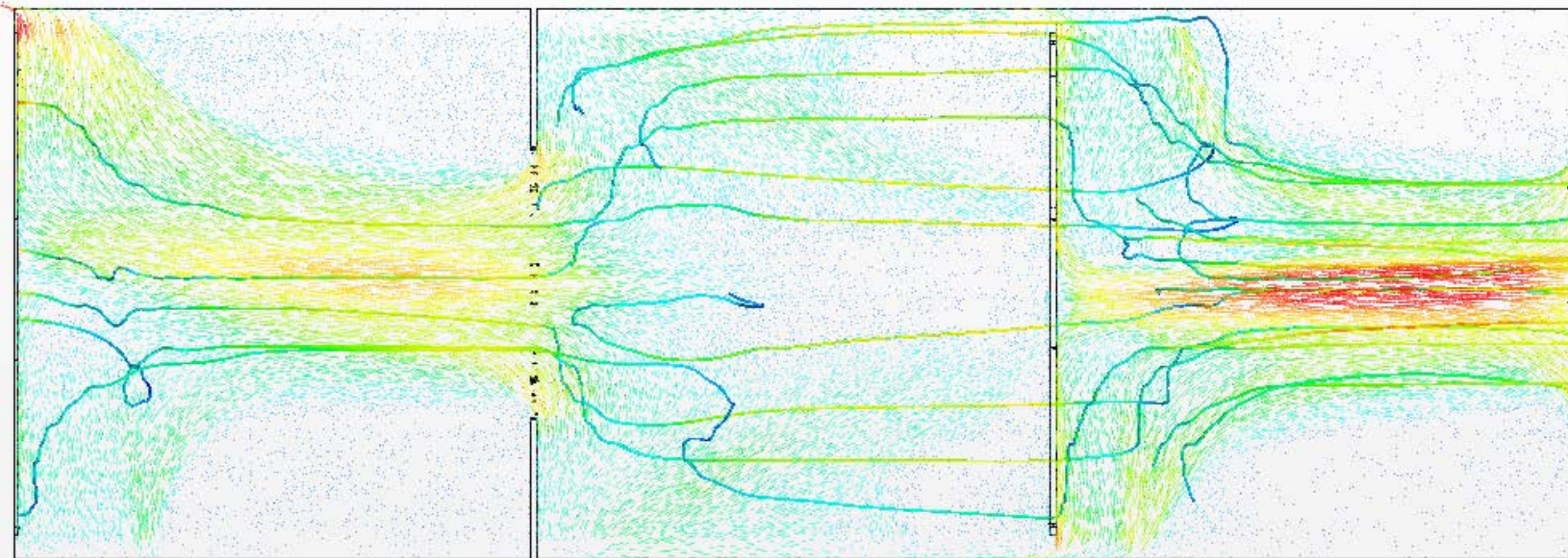

Velocity (m/s)

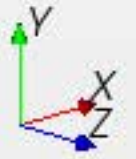
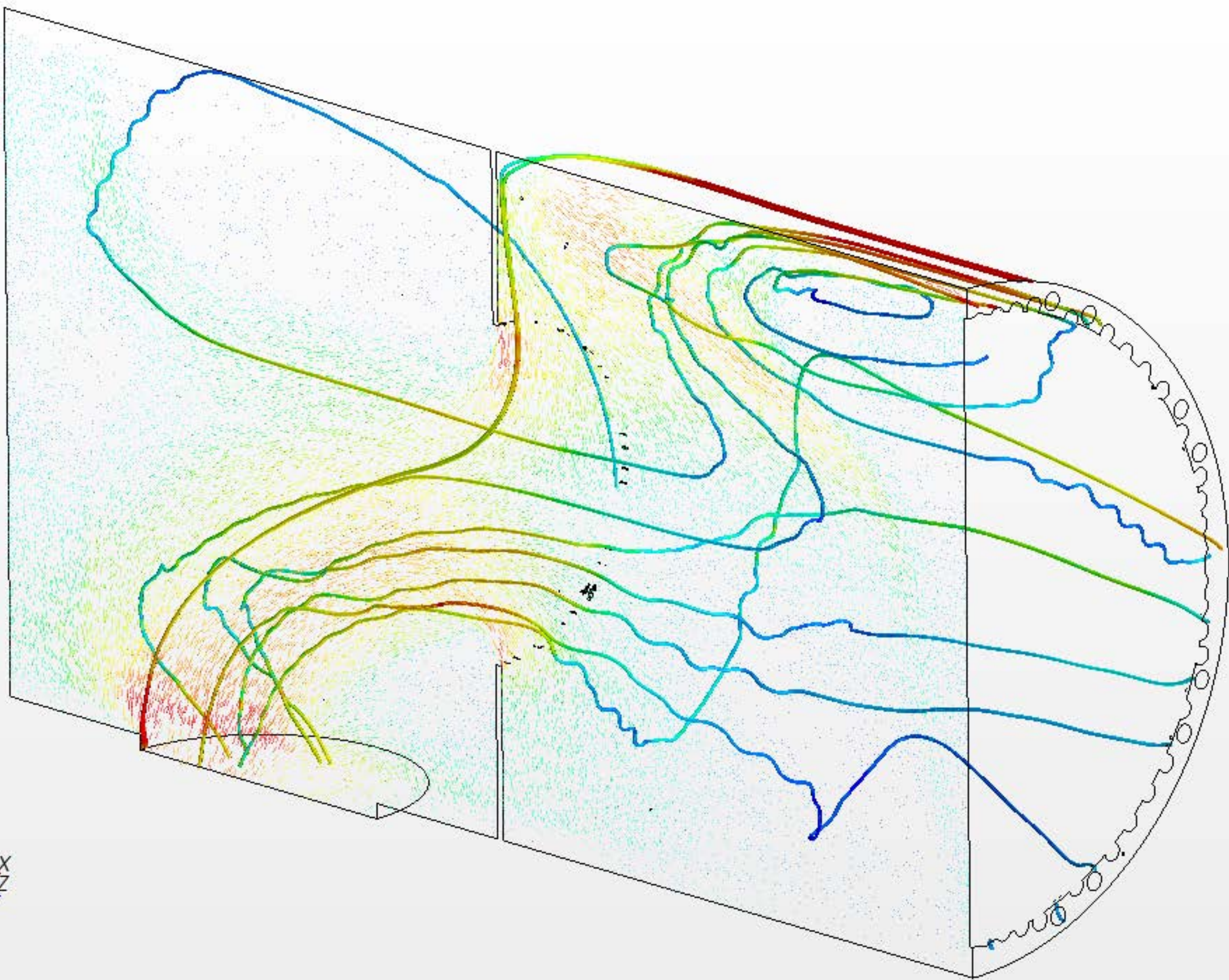

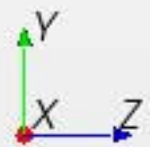
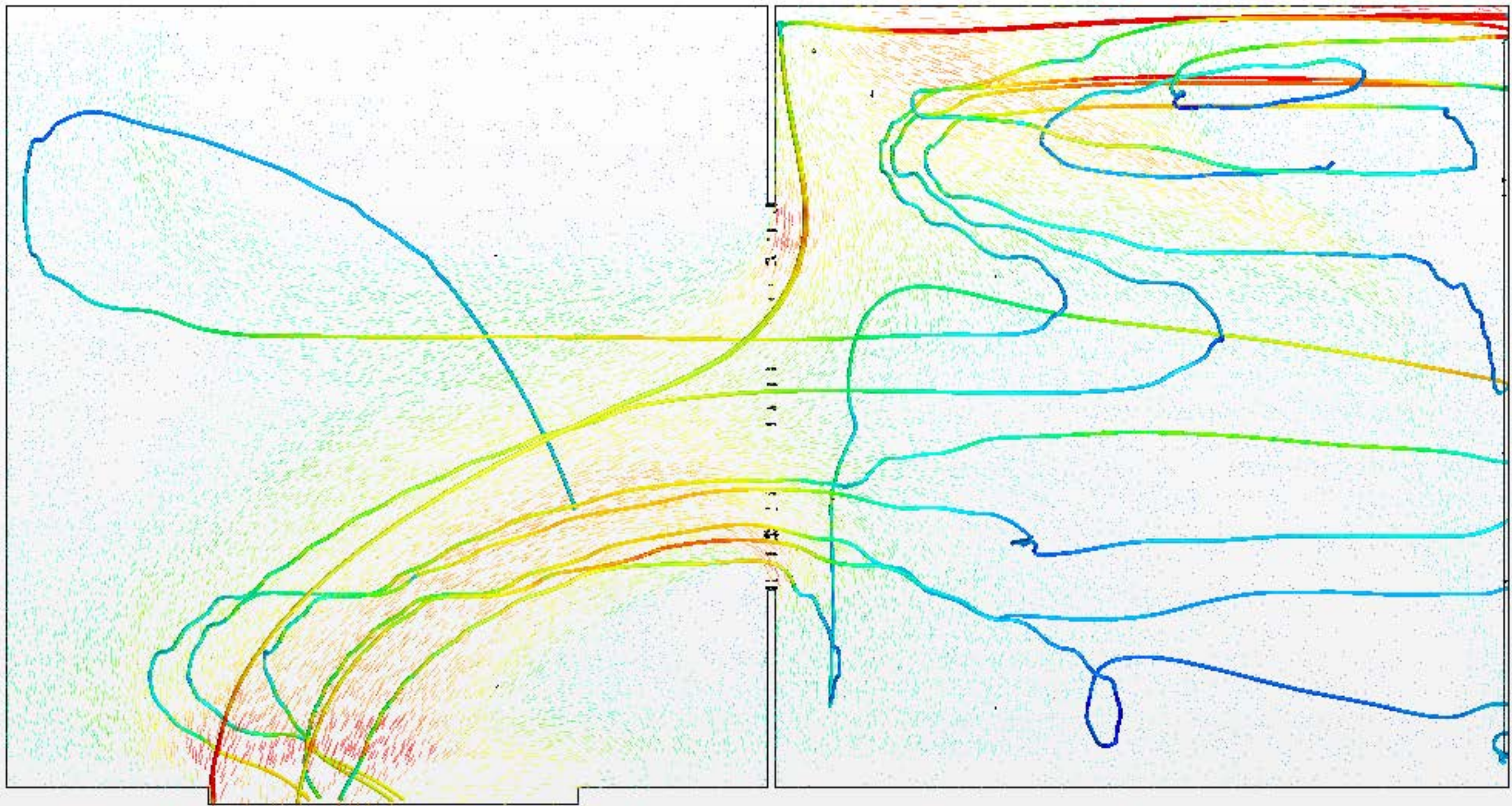

Velocity (m/s)

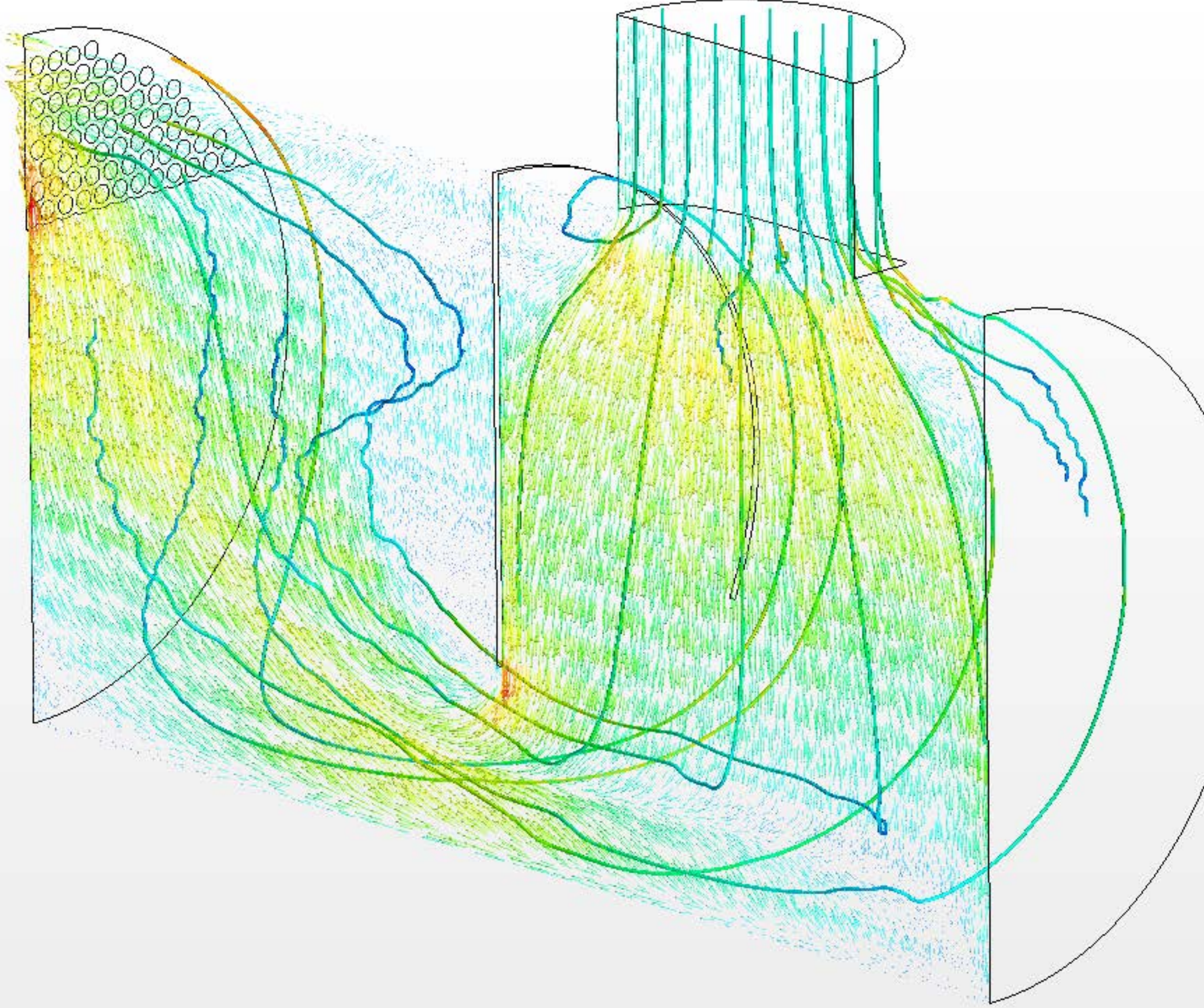

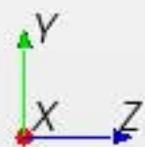
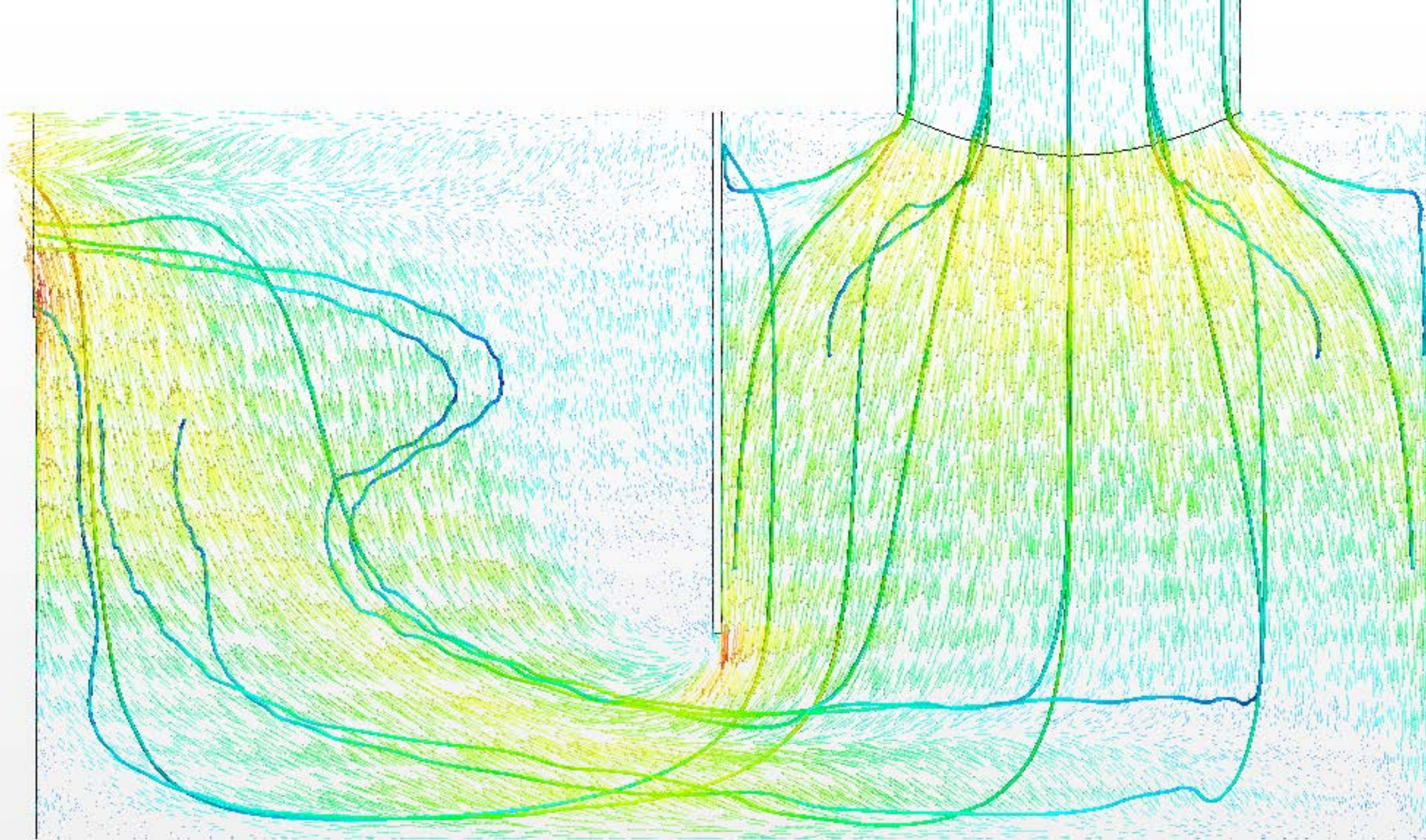

Velocity (m/s)

0.00000	0.60000	1.2000	1.8000	2.4000	3.0000
---------	---------	--------	--------	--------	--------



Velocity (m/s)

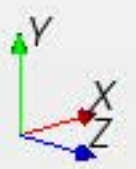
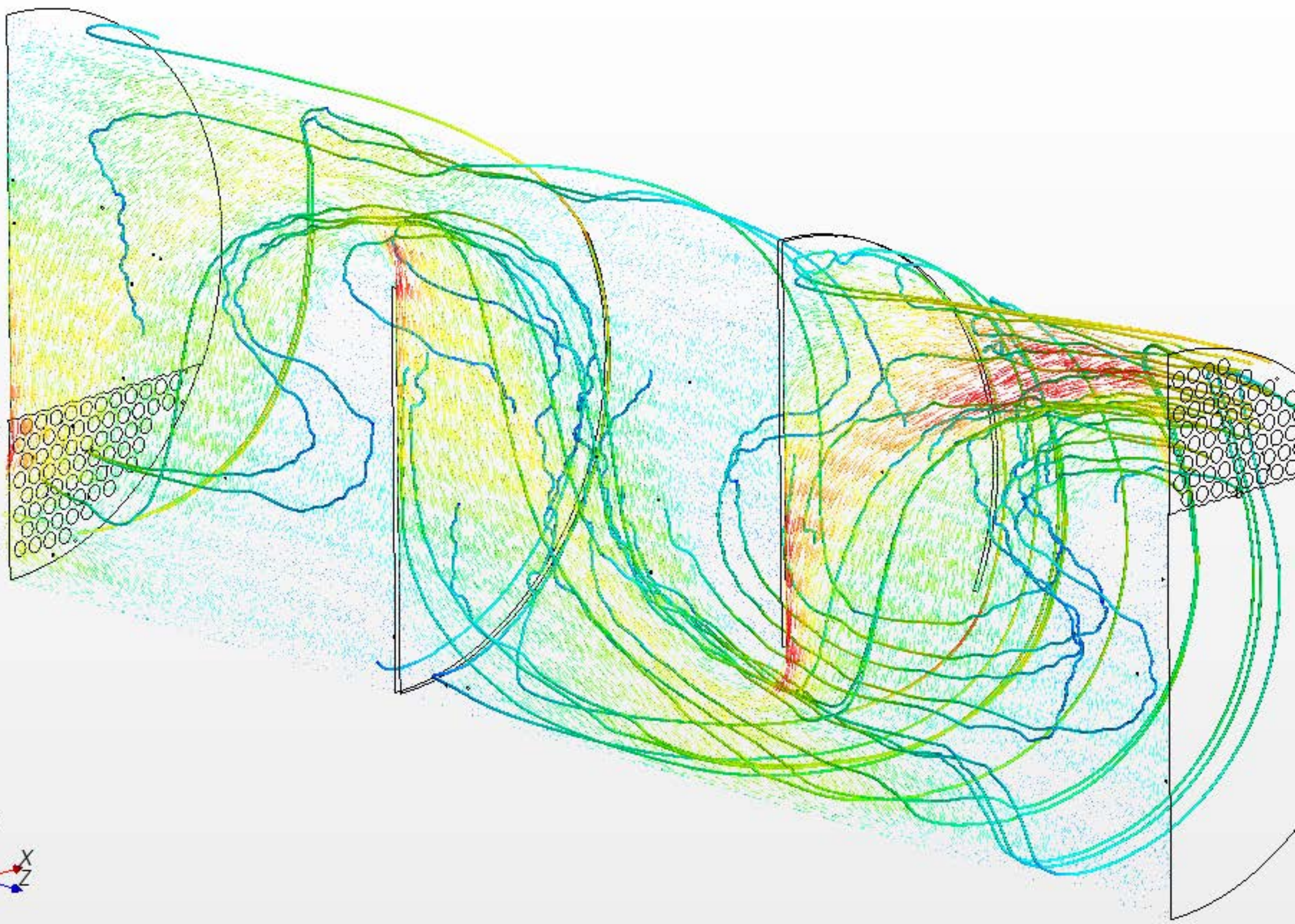
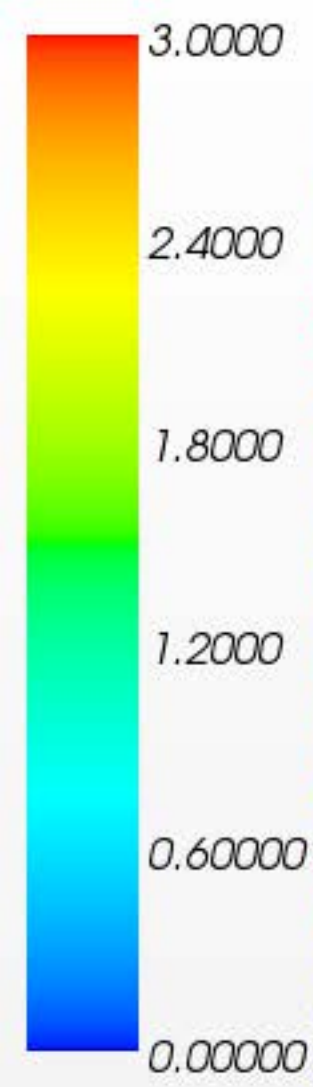

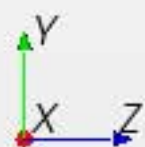
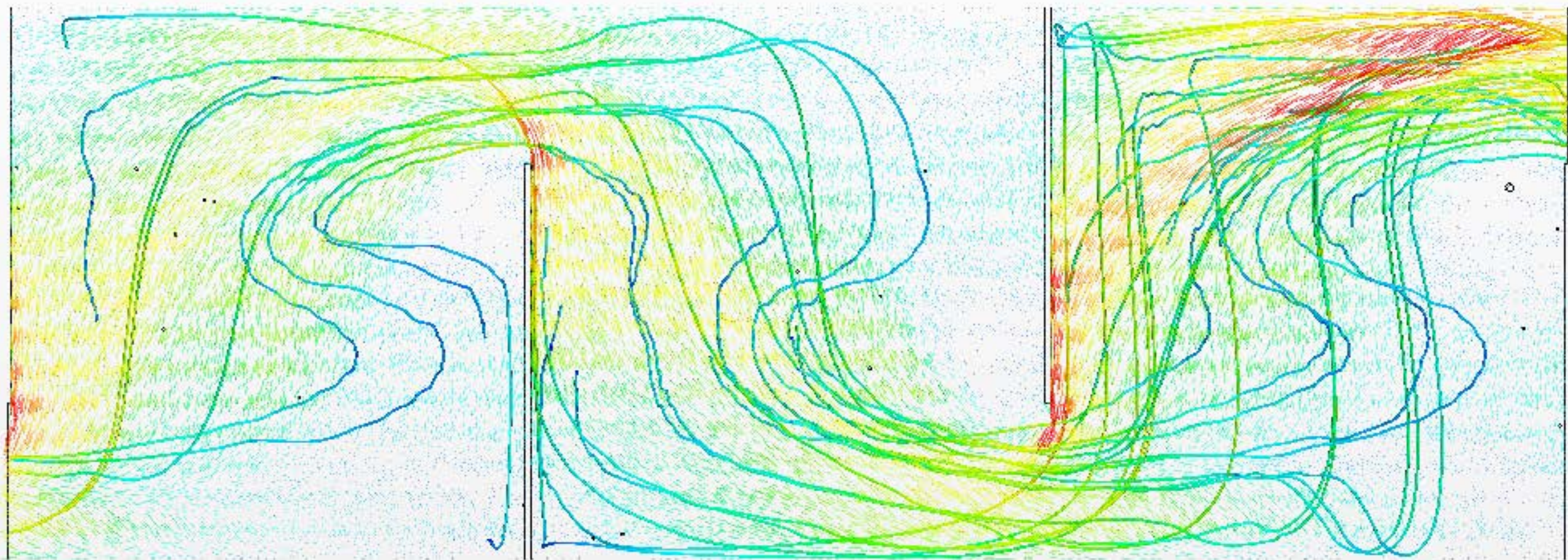

Velocity (m/s)

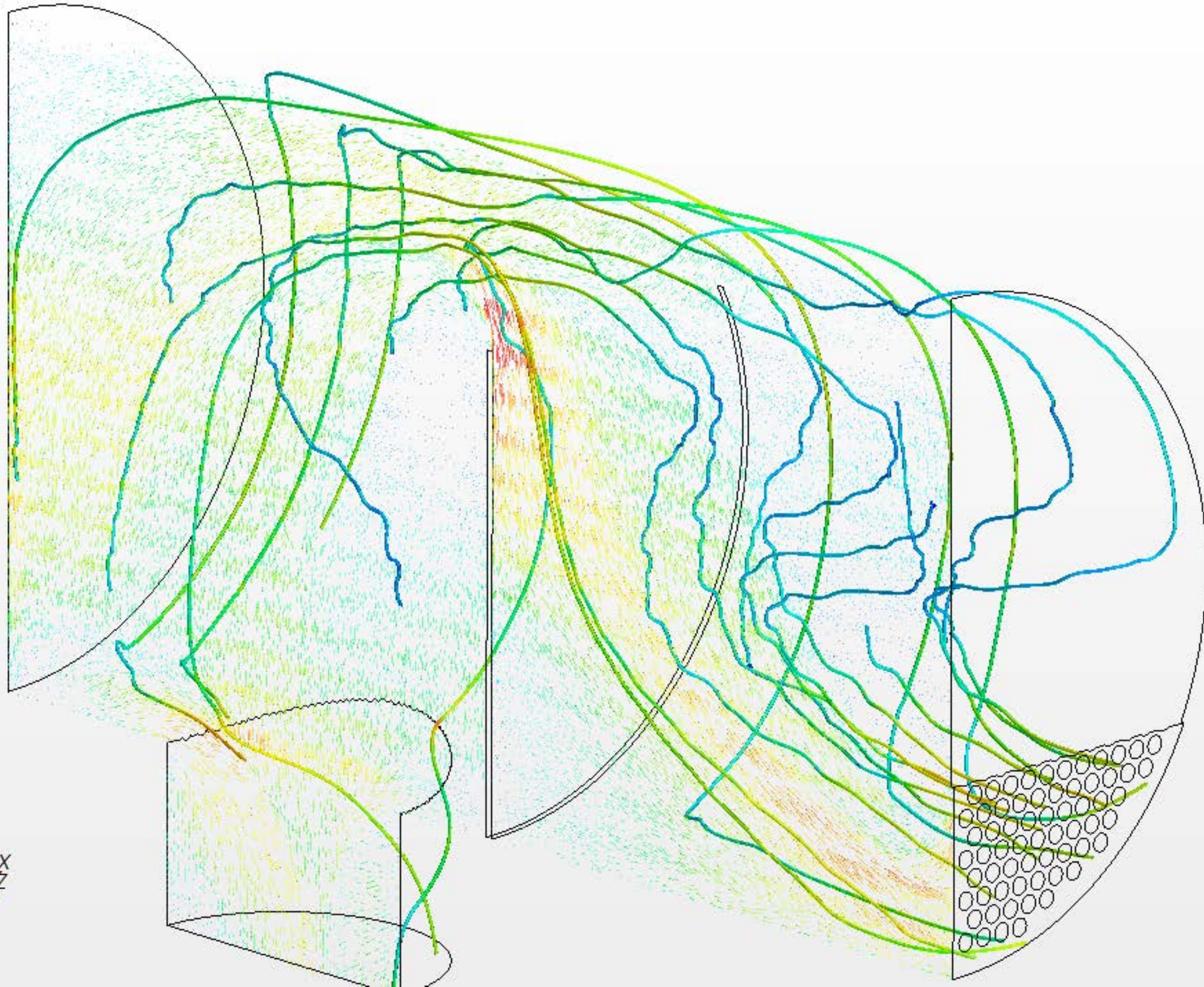
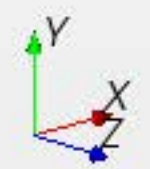

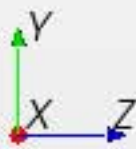
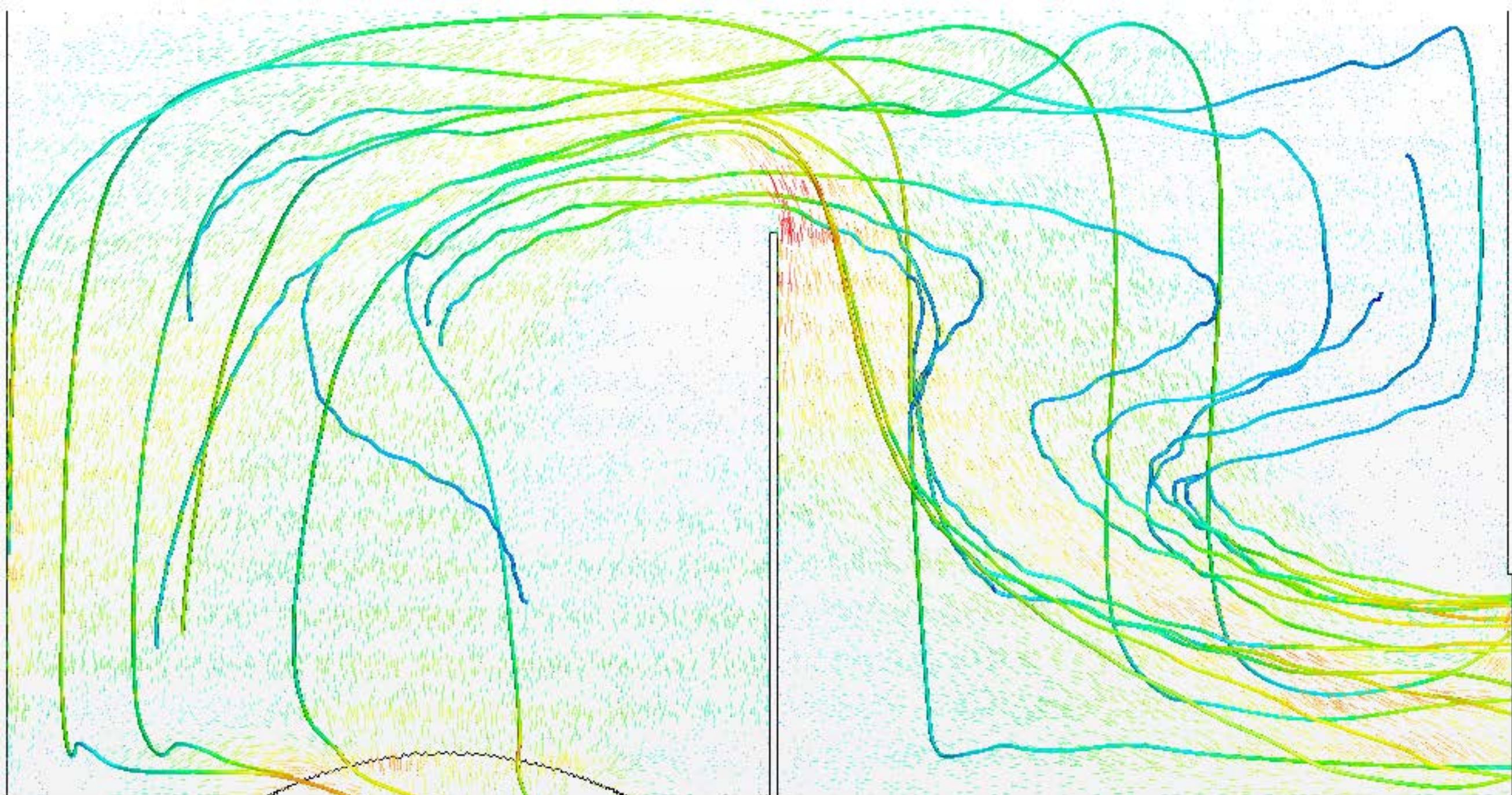

0.00000 0.60000 1.2000 1.8000 2.4000 3.0000



Velocity (m/s)

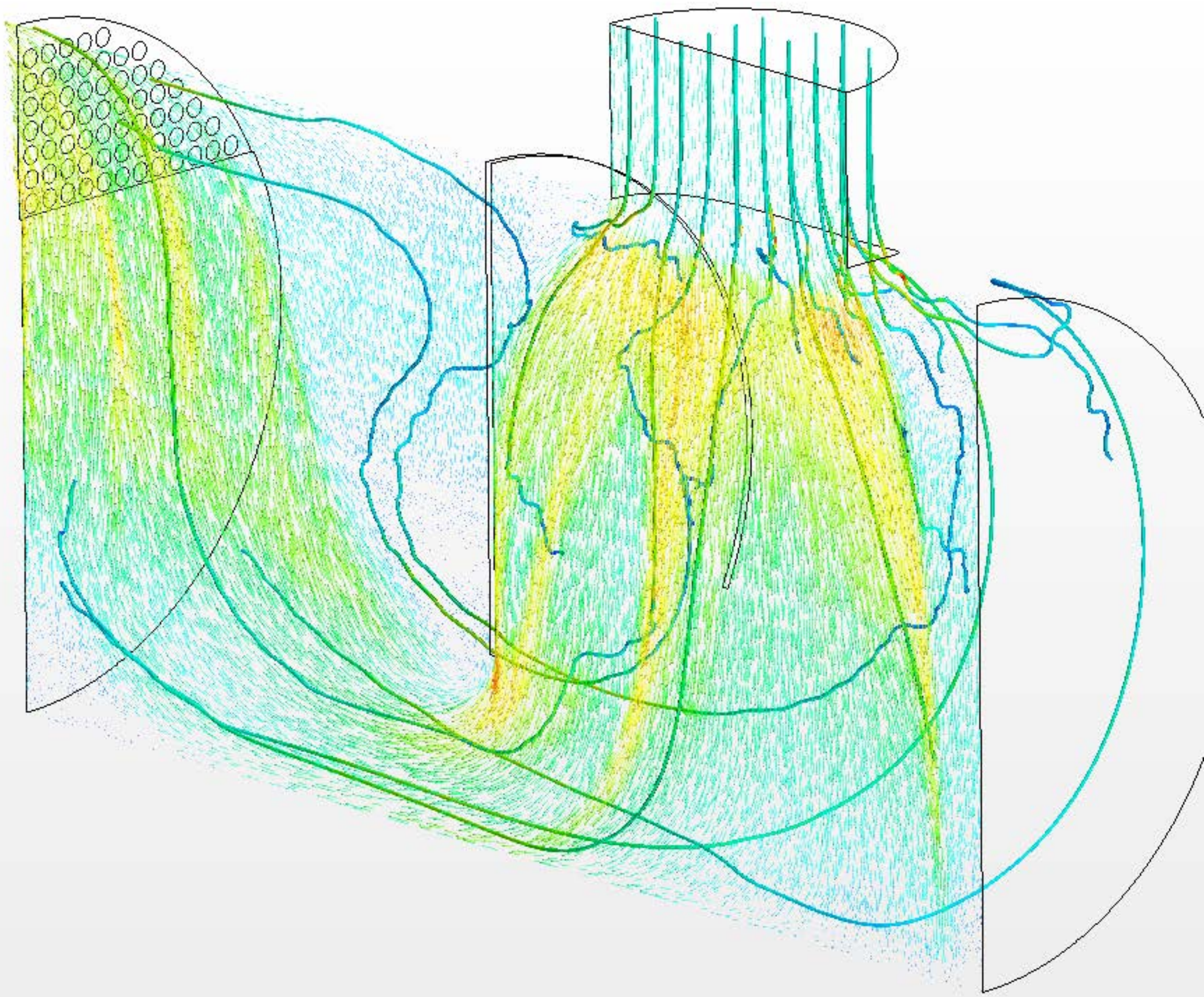

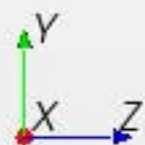
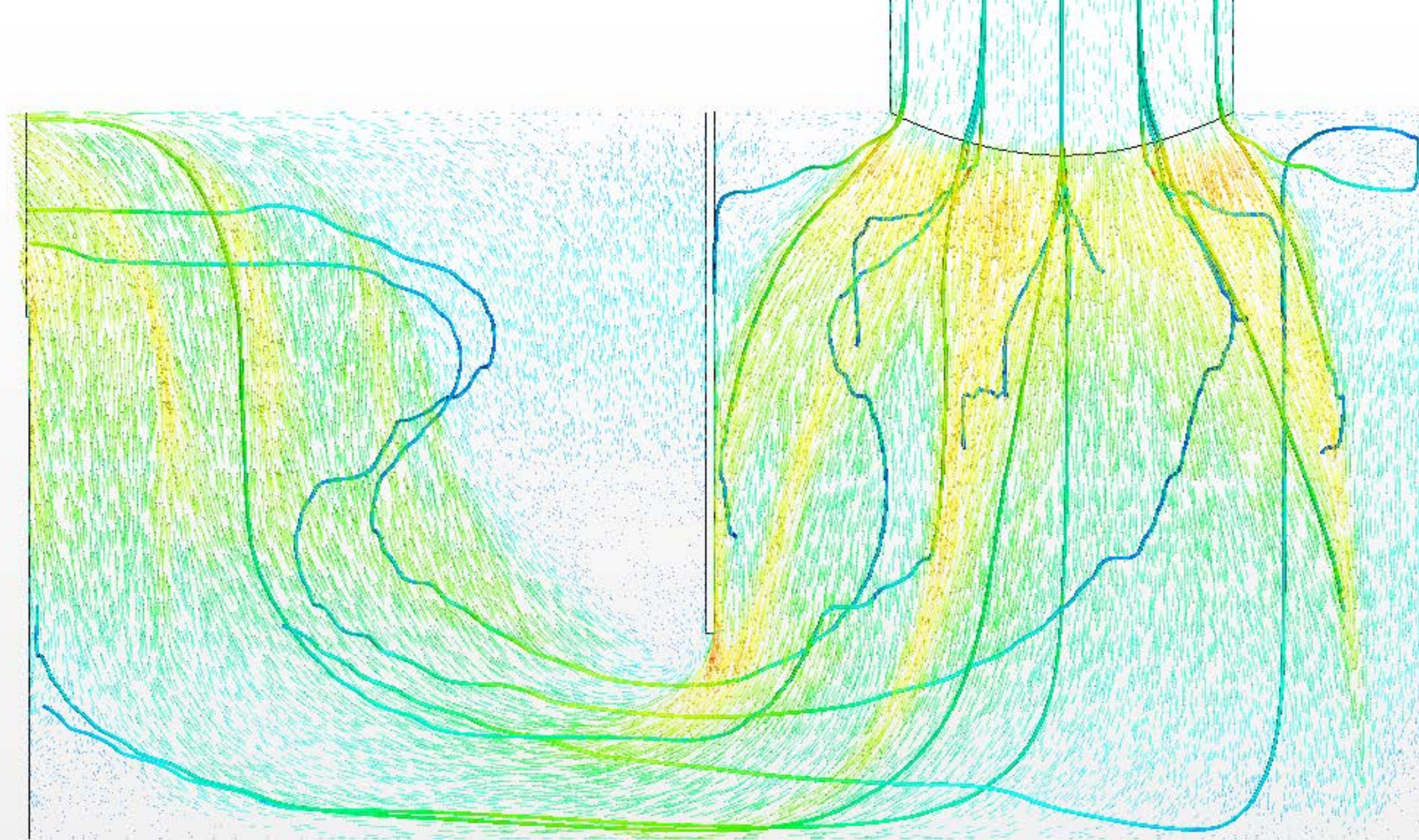

Velocity (m/s)

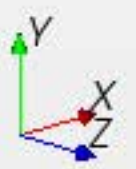
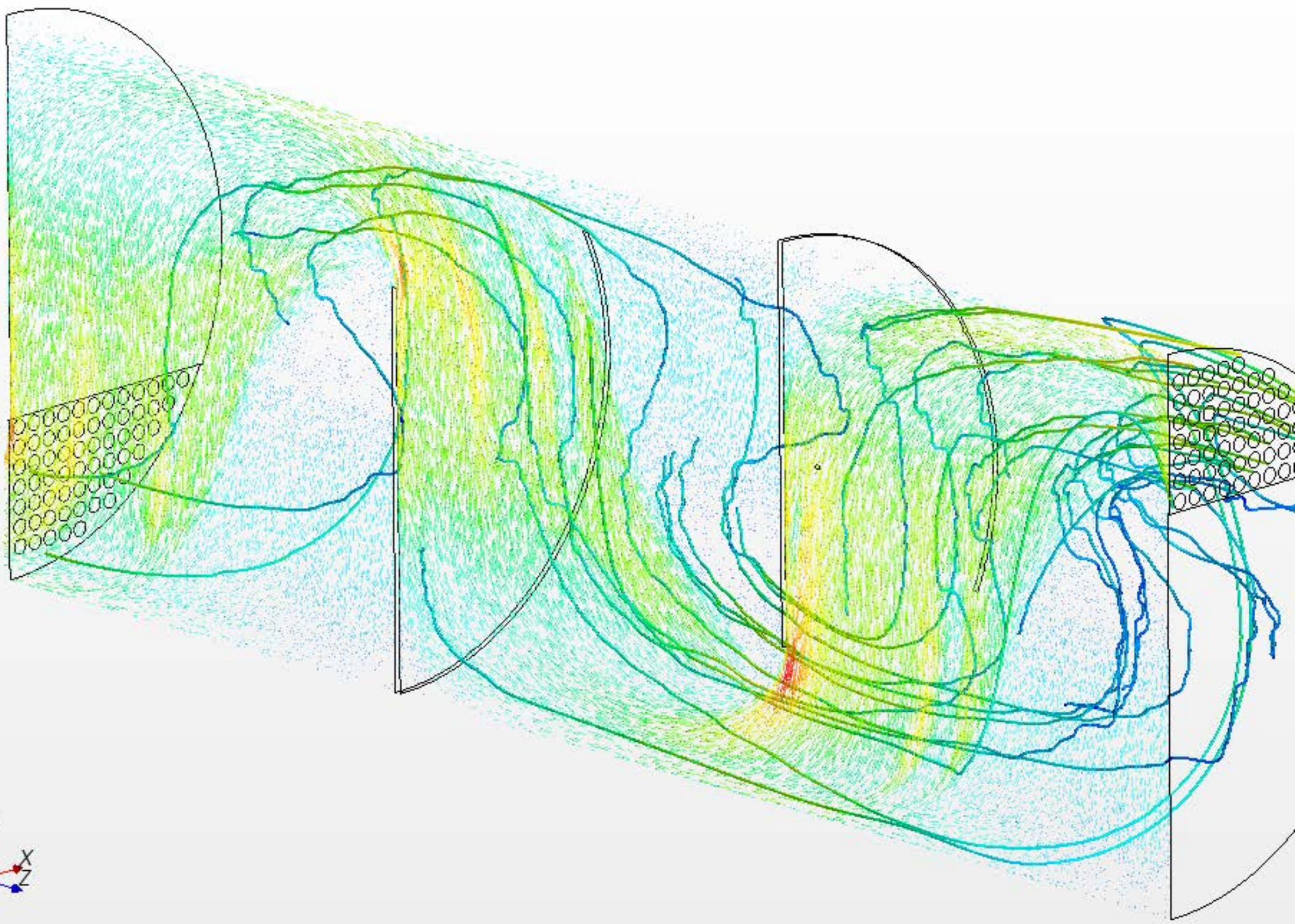
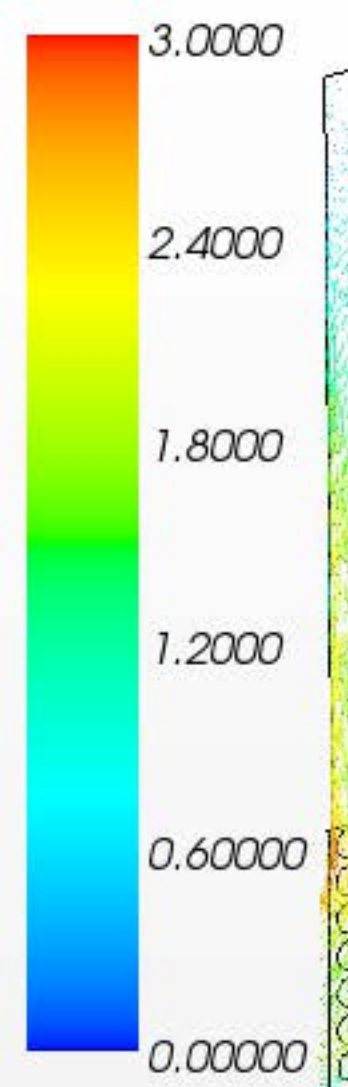

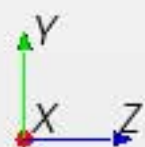
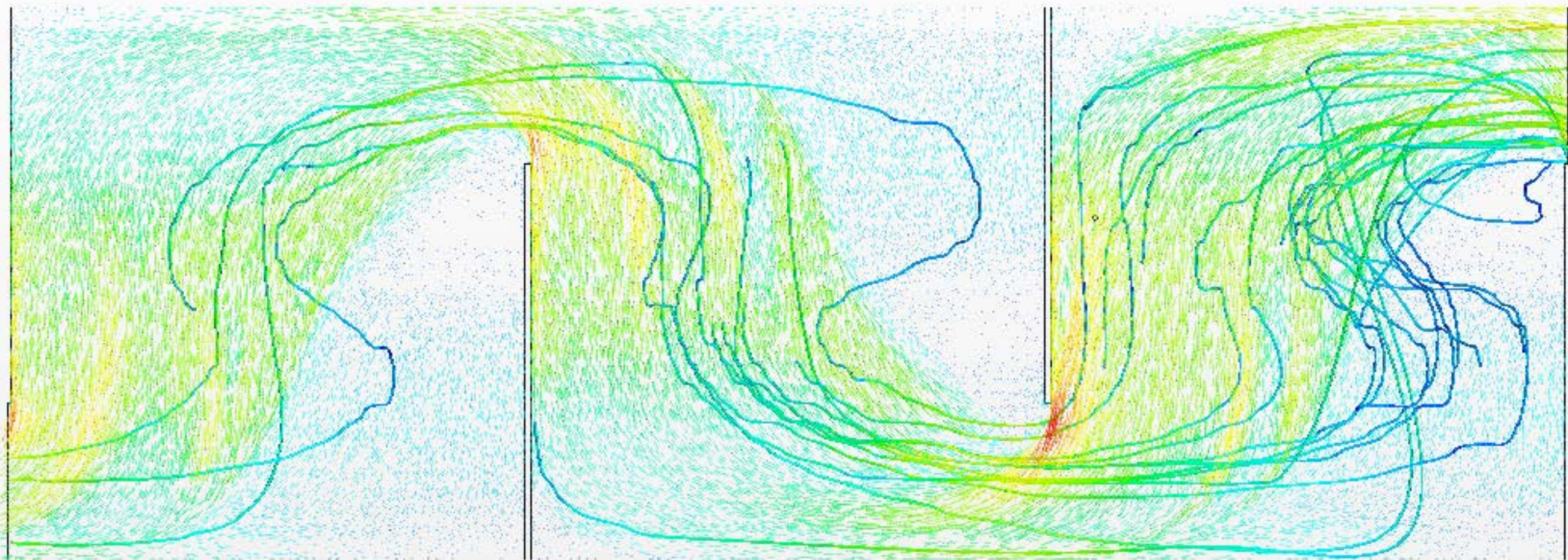

Velocity (m/s)

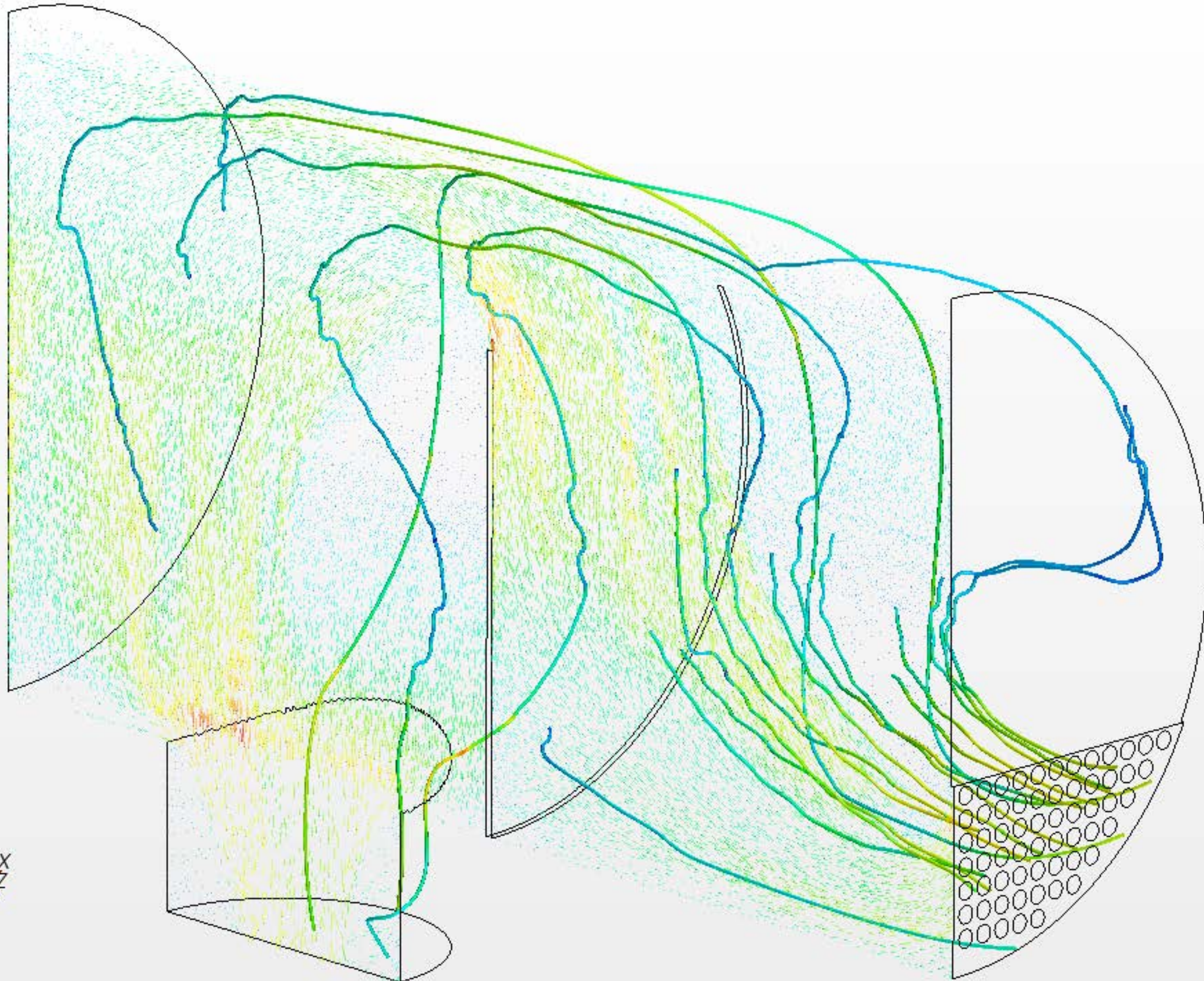
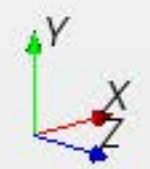

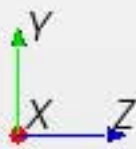
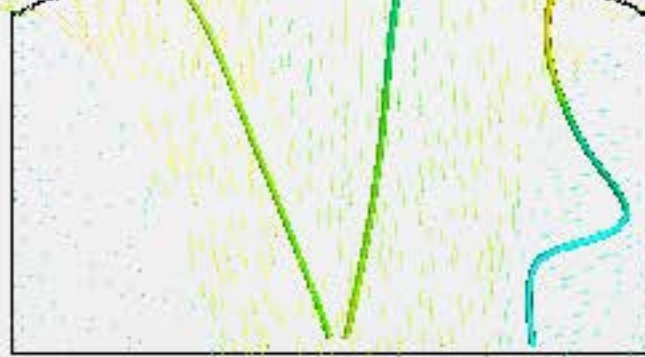
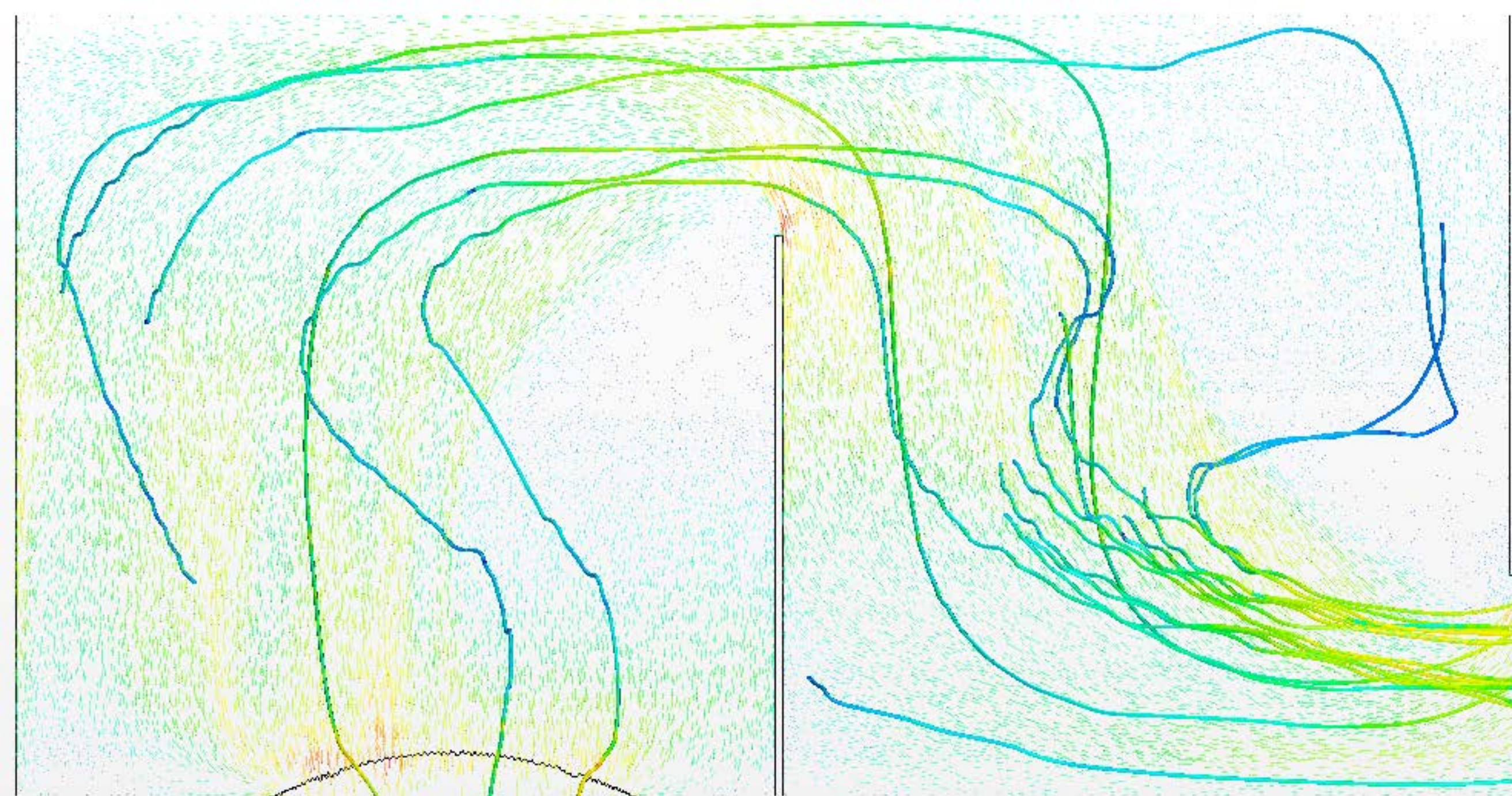

0.00000 0.60000 1.2000 1.8000 2.4000 3.0000

Velocity (m/s)



Velocity: Magnitude (m/s)

Appendix H

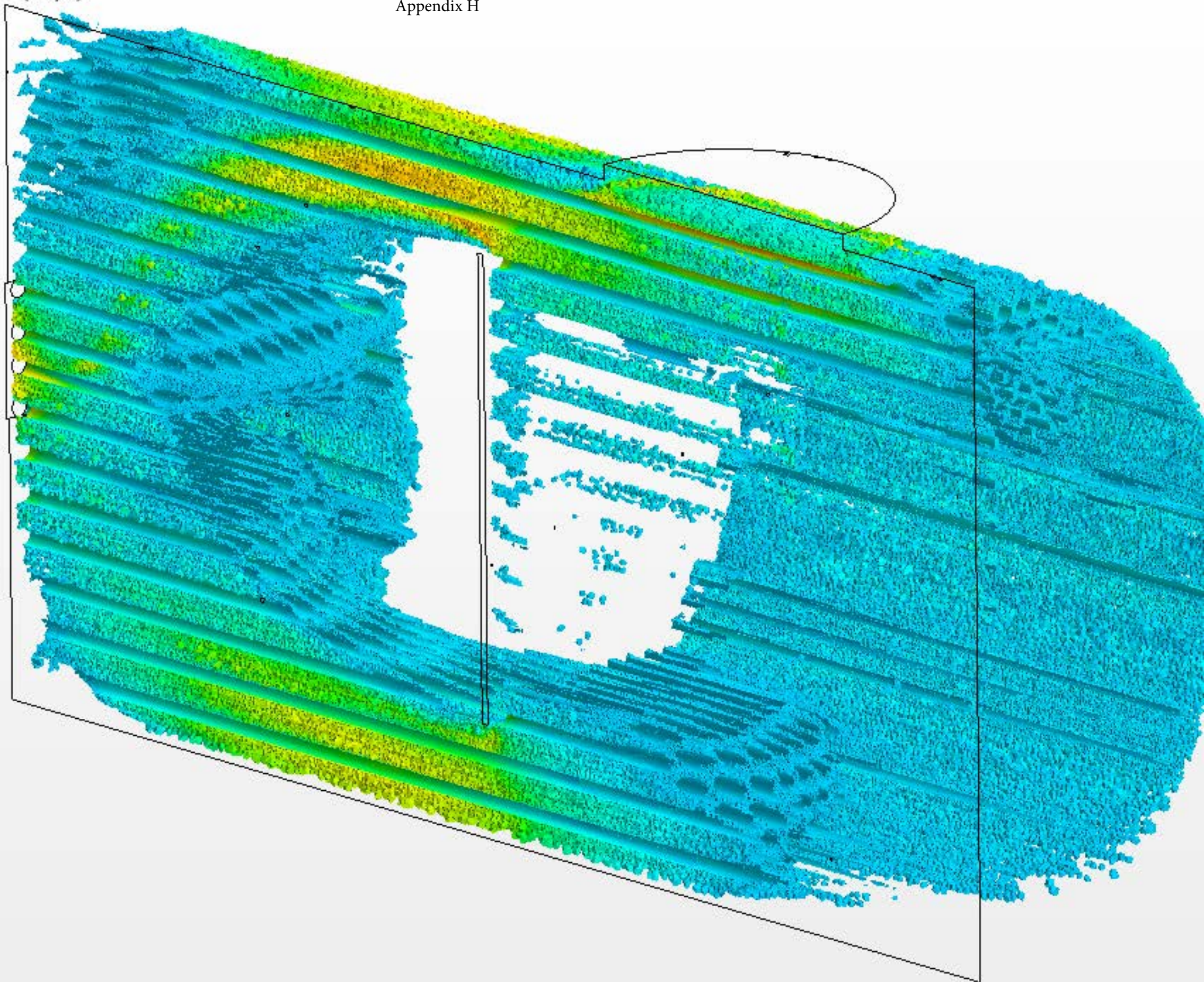

Velocity: Magnitude (m/s)

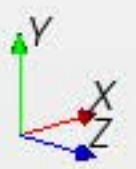
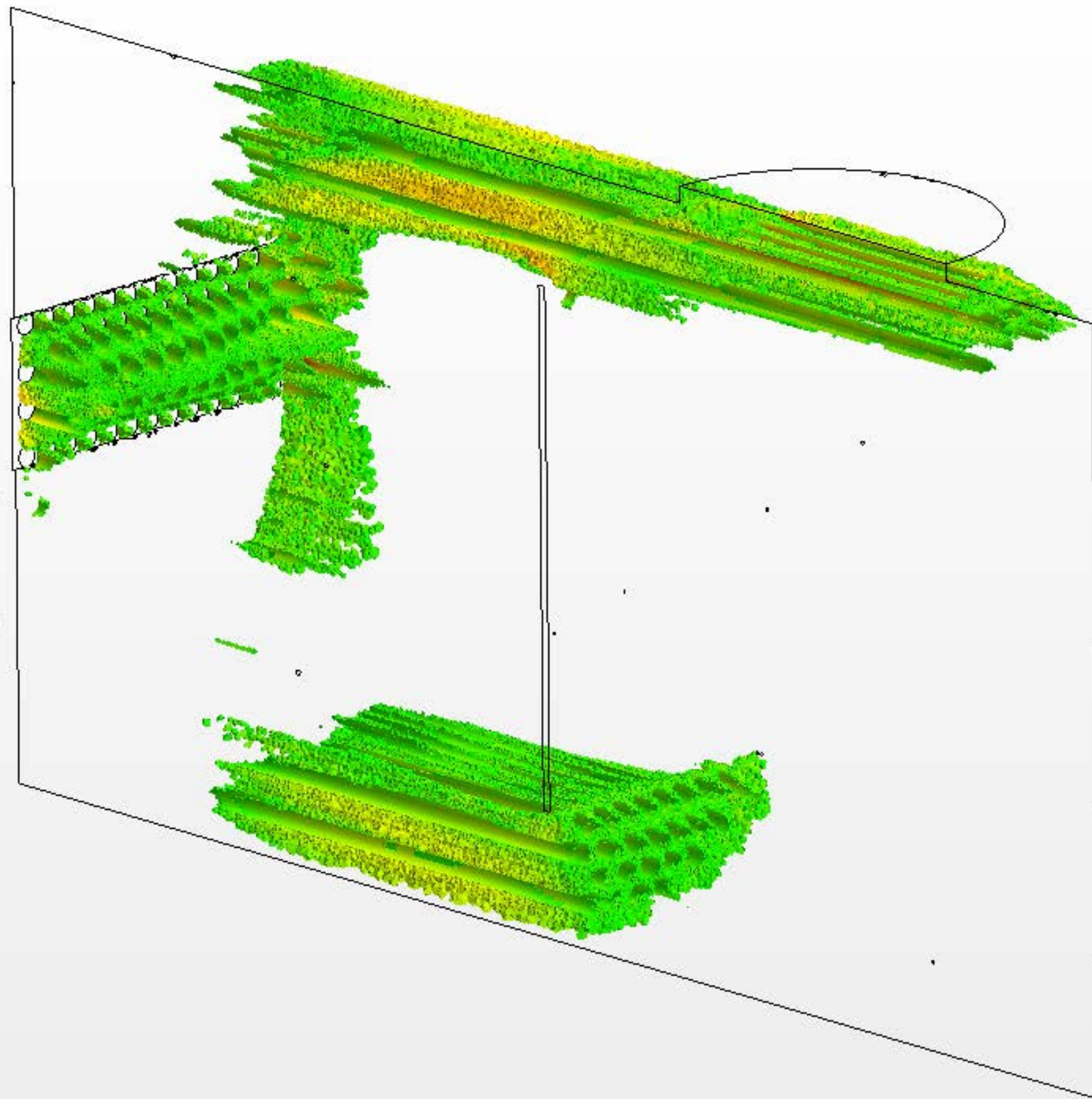
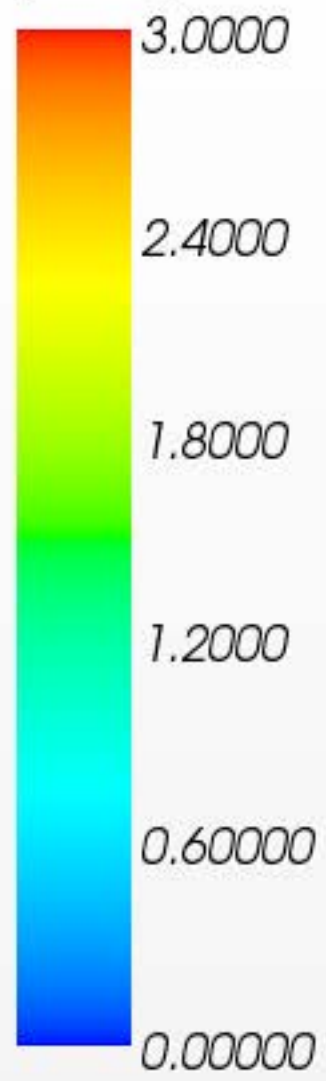

Velocity: Magnitude (m/s)

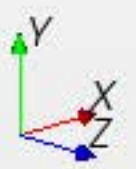
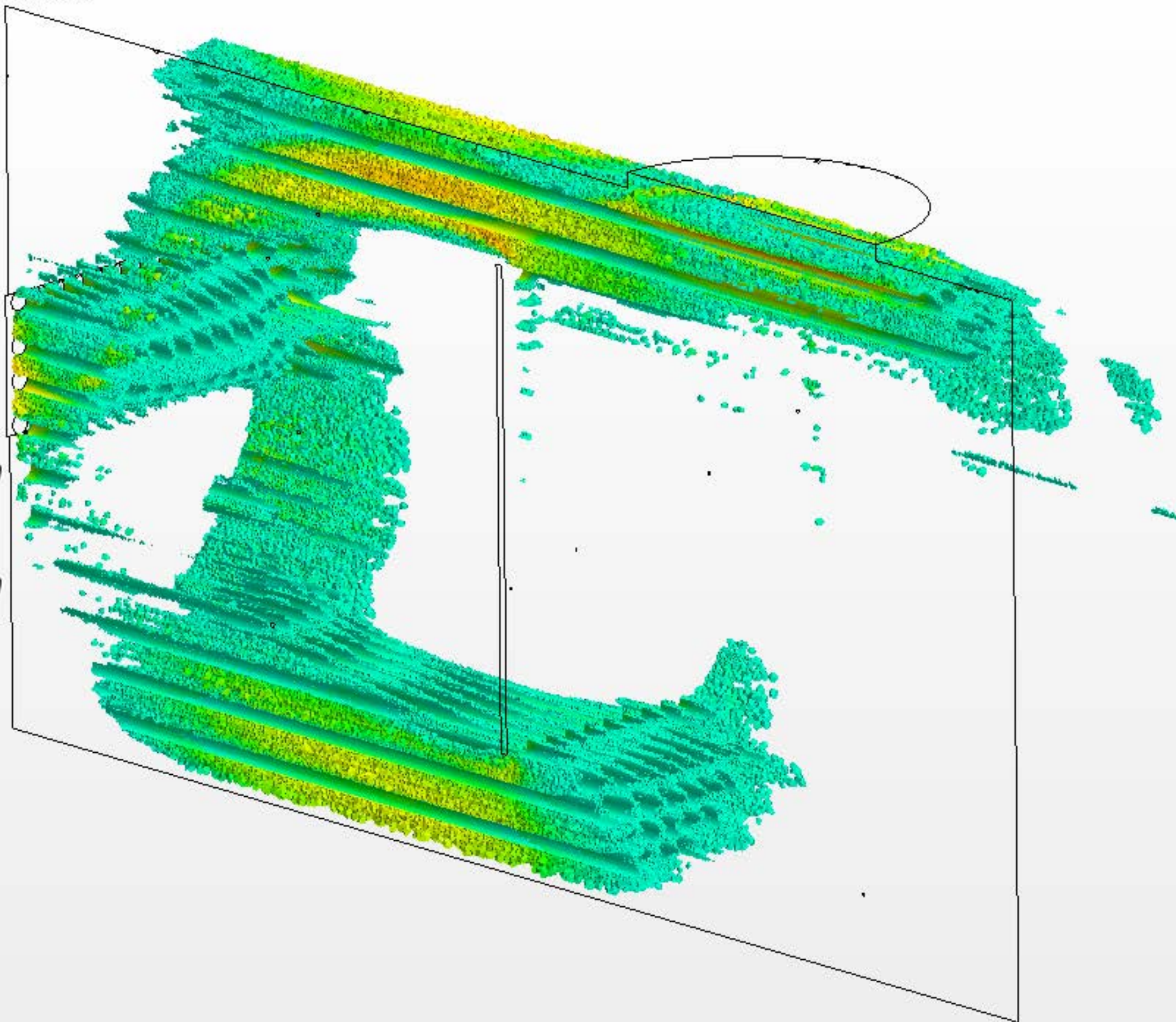

Velocity: Magnitude (m/s)

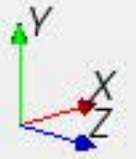
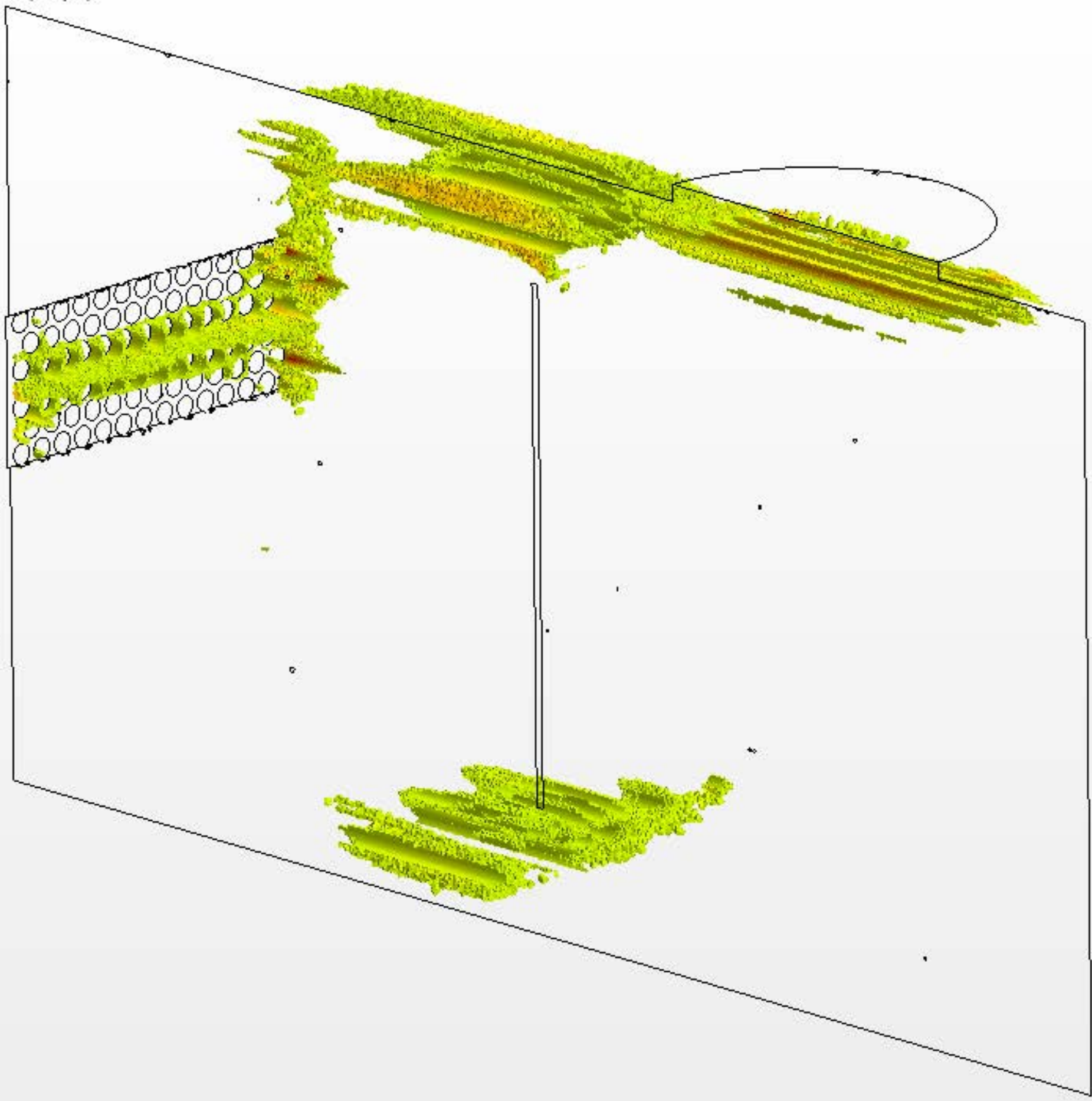
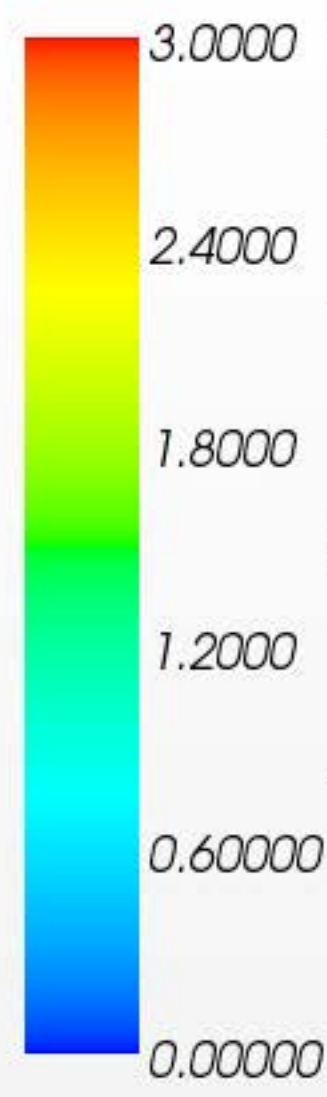

Velocity: Magnitude (m/s)

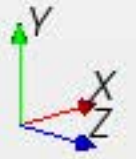
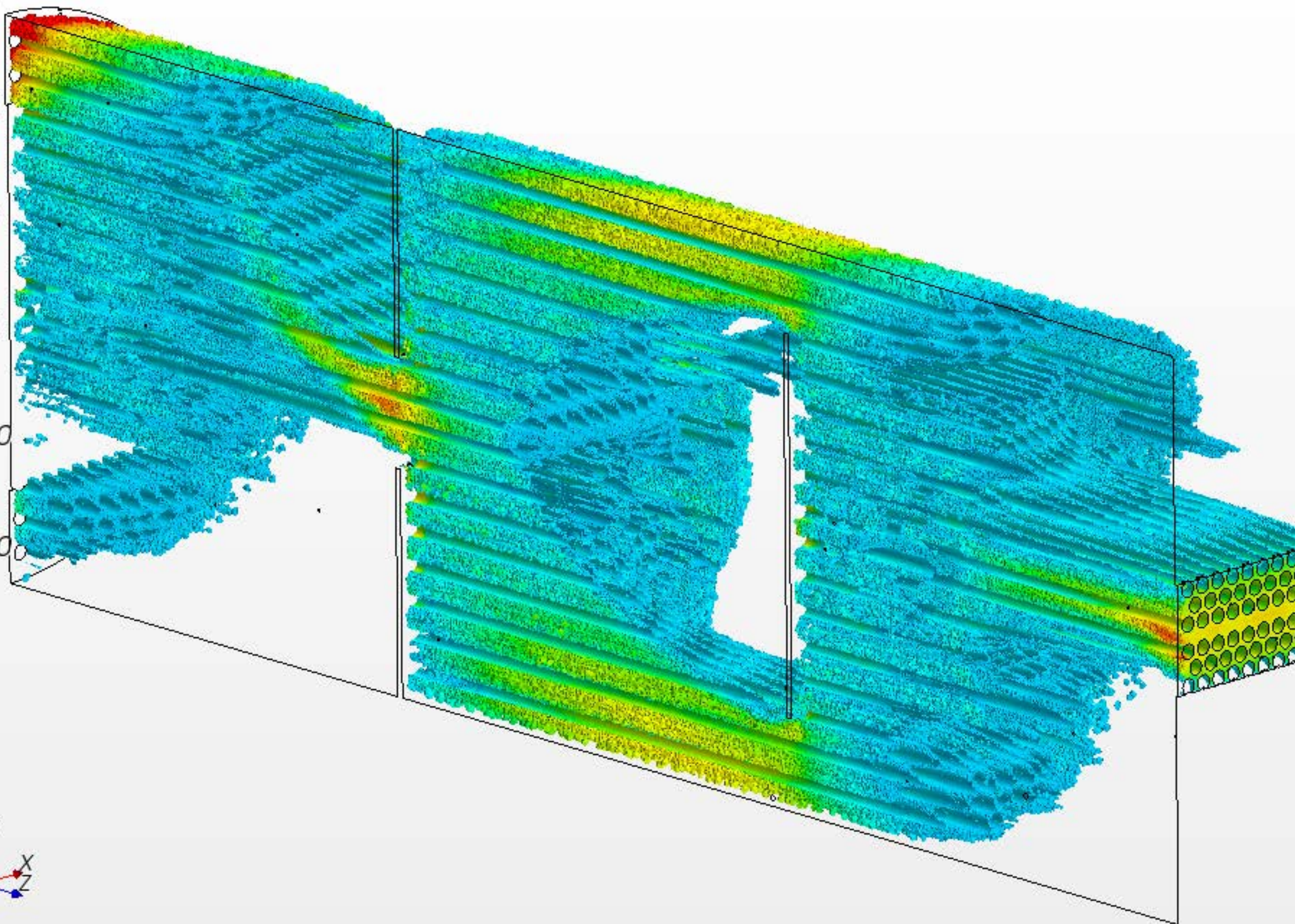
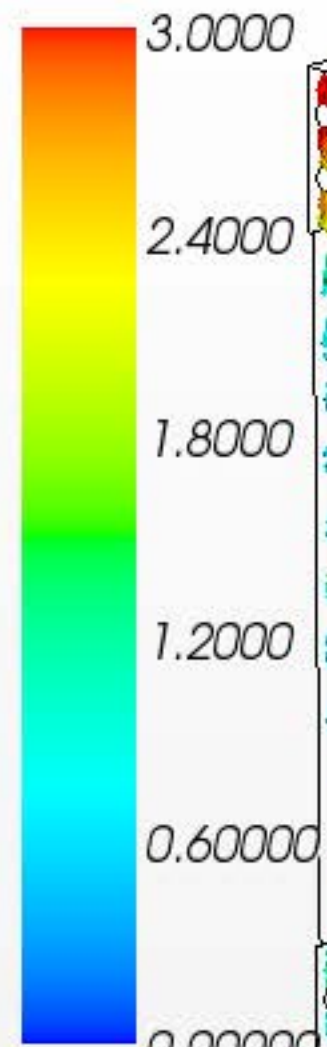

ity: Magnitude (m/s)

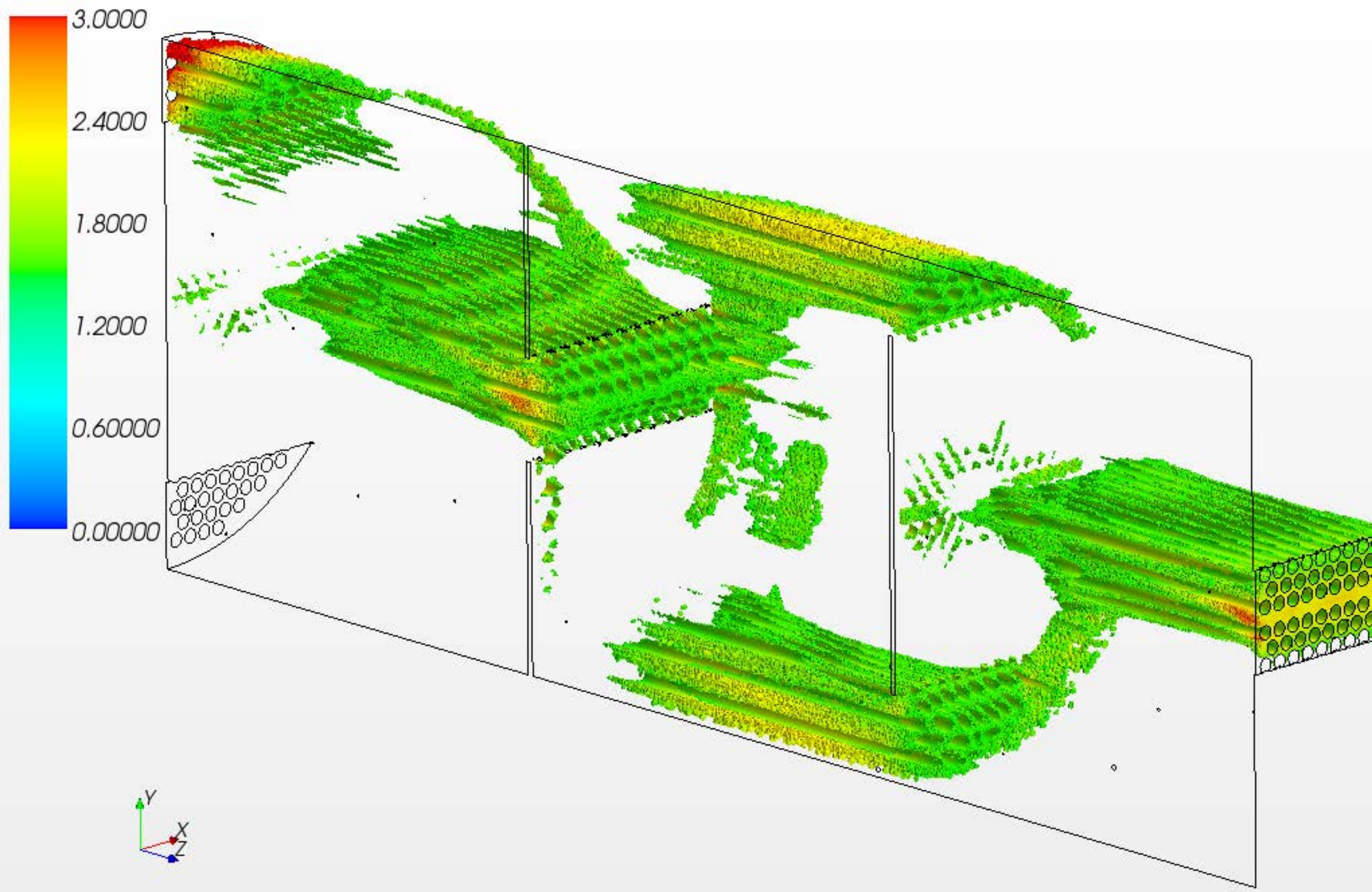

Velocity: Magnitude (m/s)

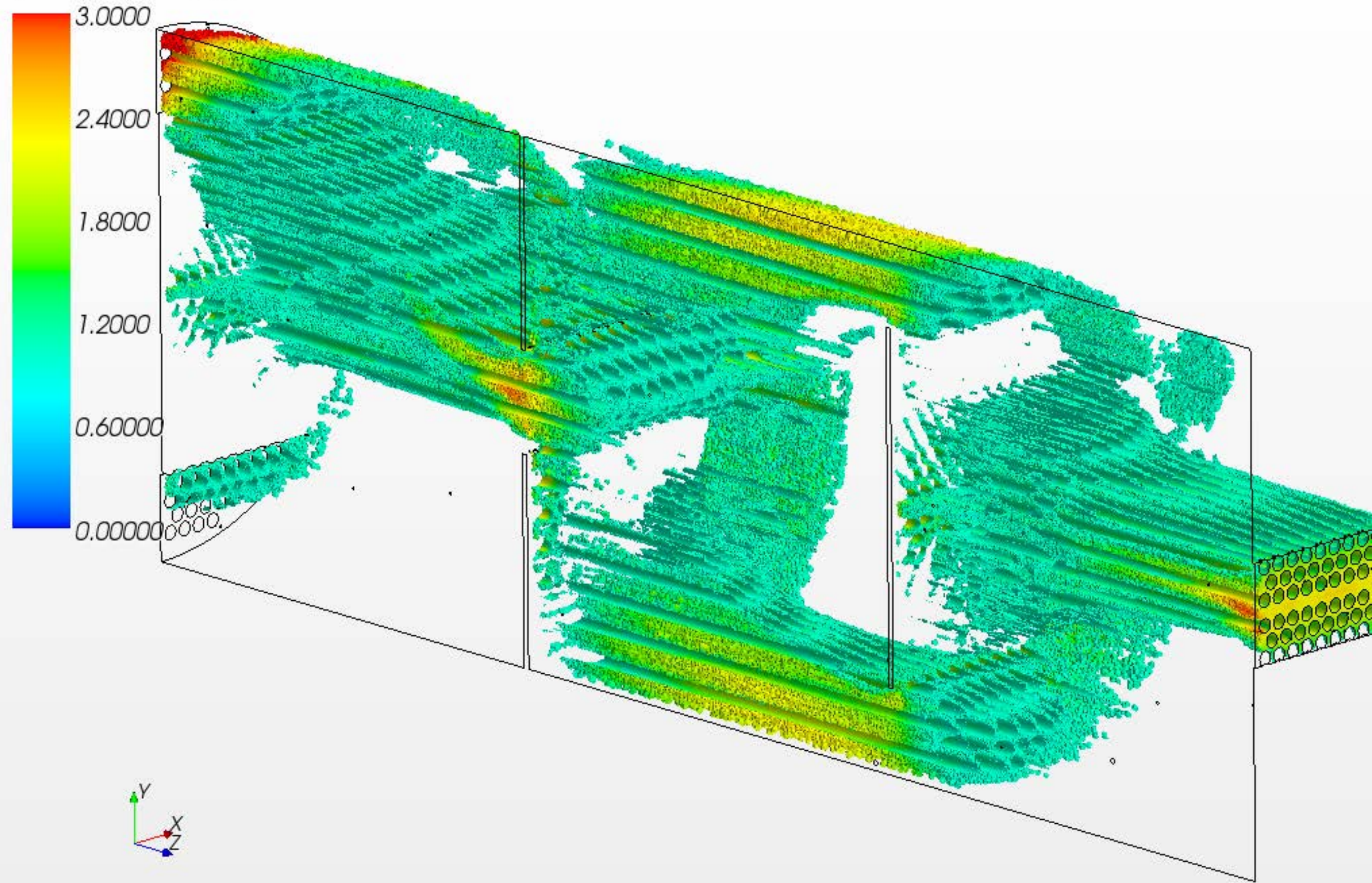

Velocity: Magnitude (m/s)

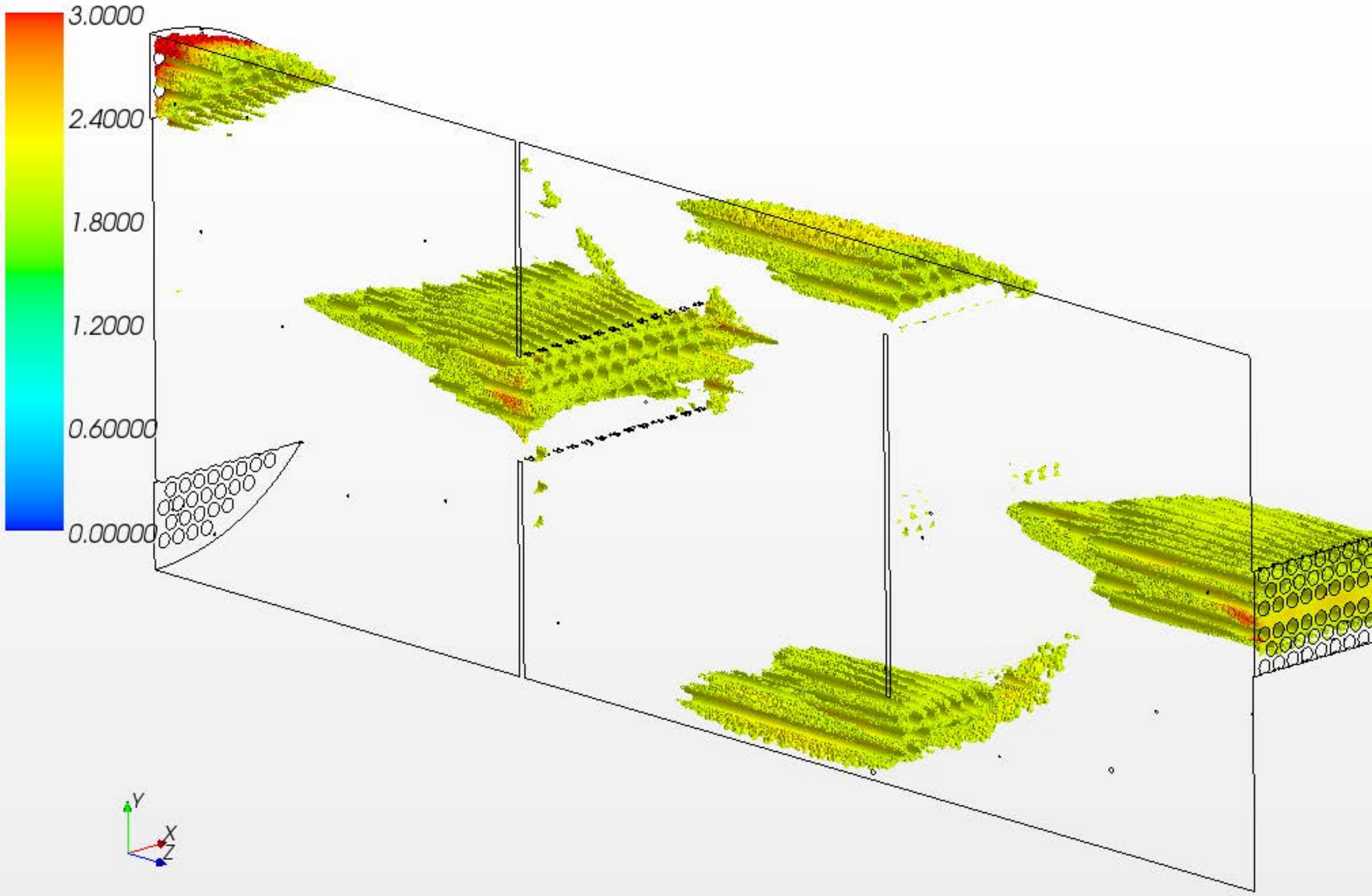

Velocity: Magnitude (m/s)

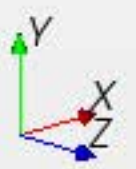
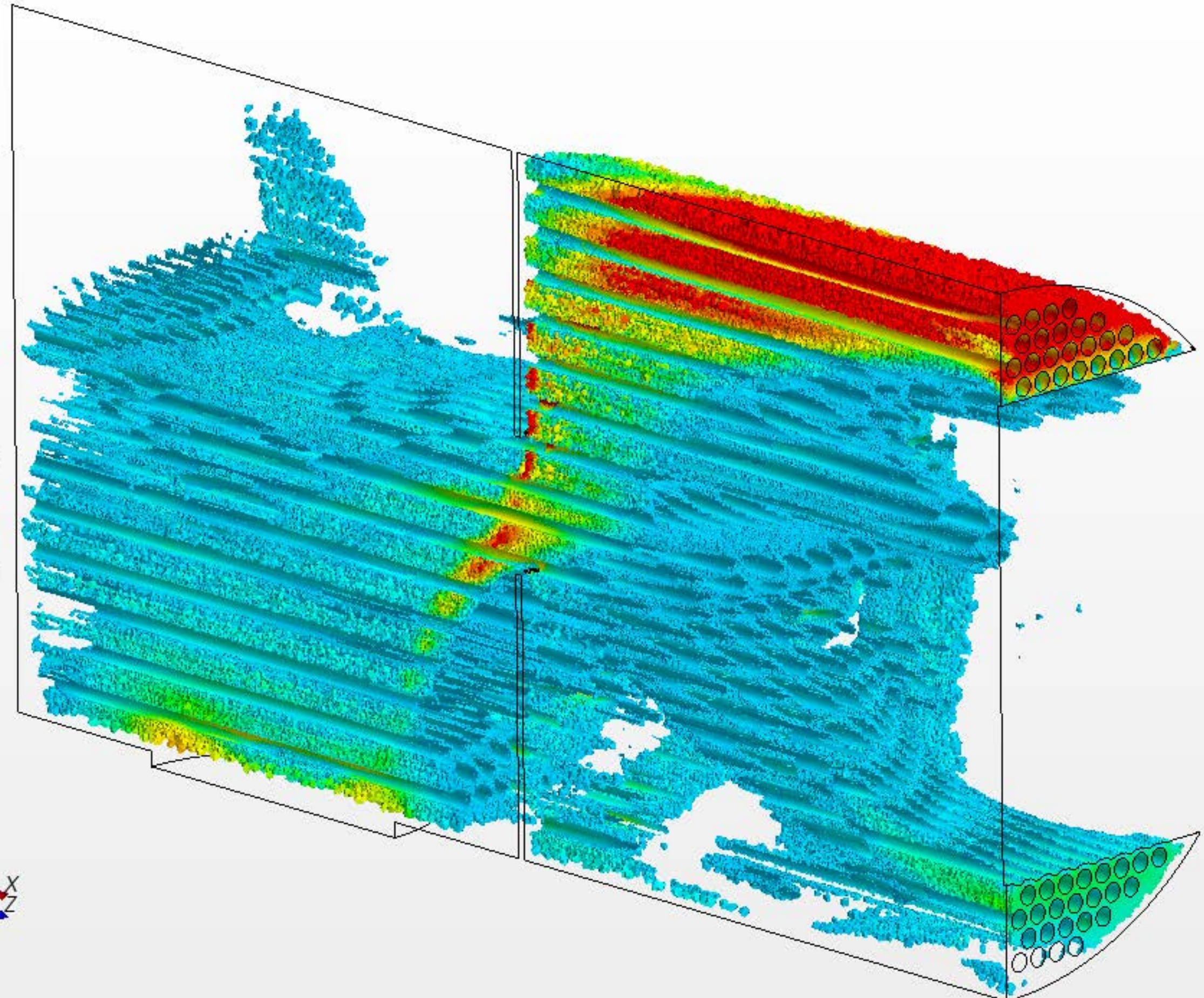

Velocity: Magnitude (m/s)

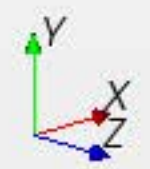
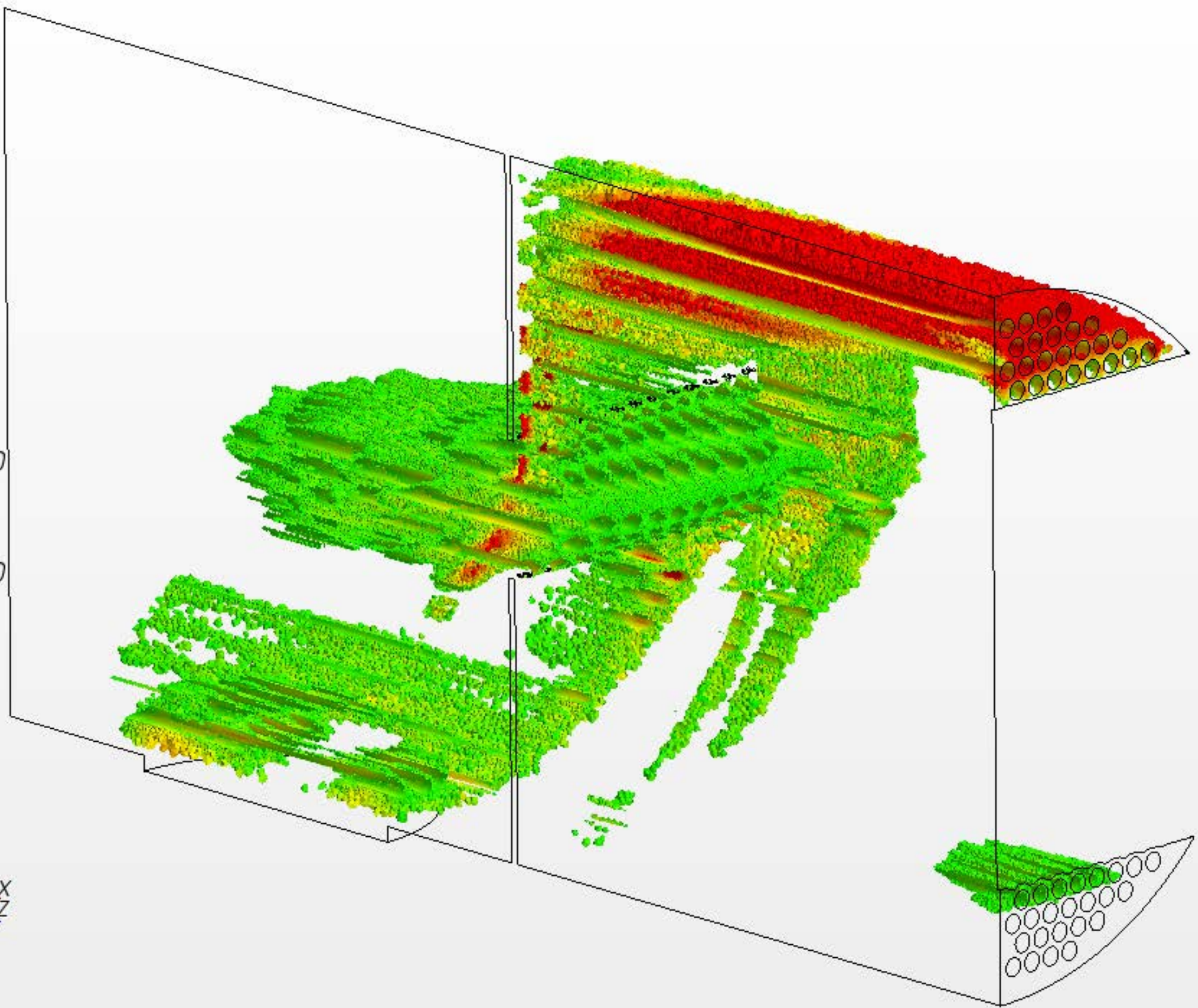
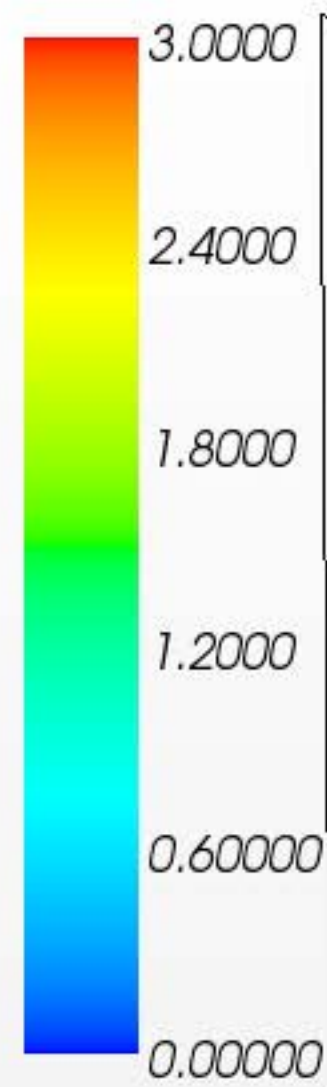

Velocity: Magnitude (m/s)

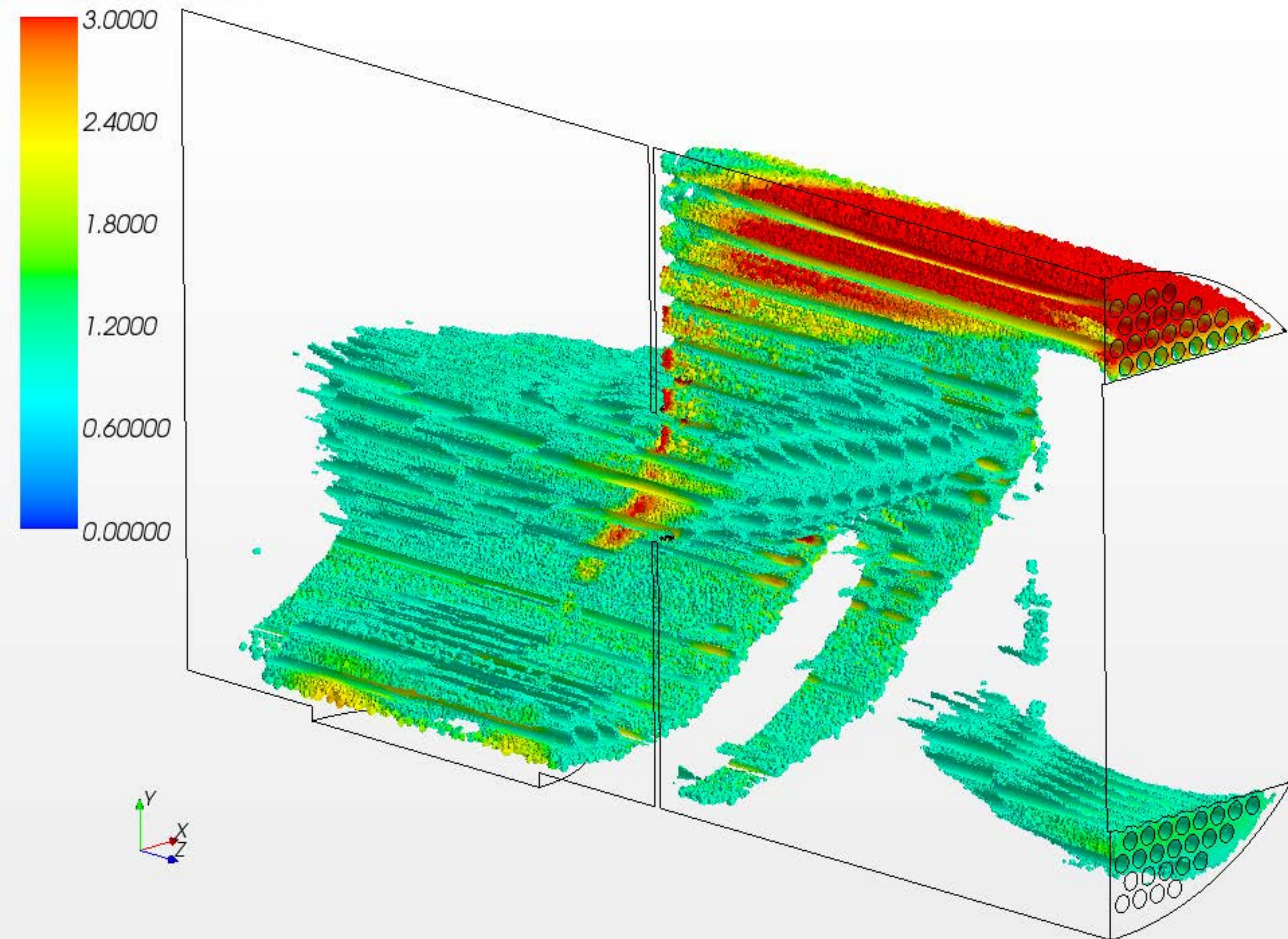

Velocity: Magnitude (m/s)

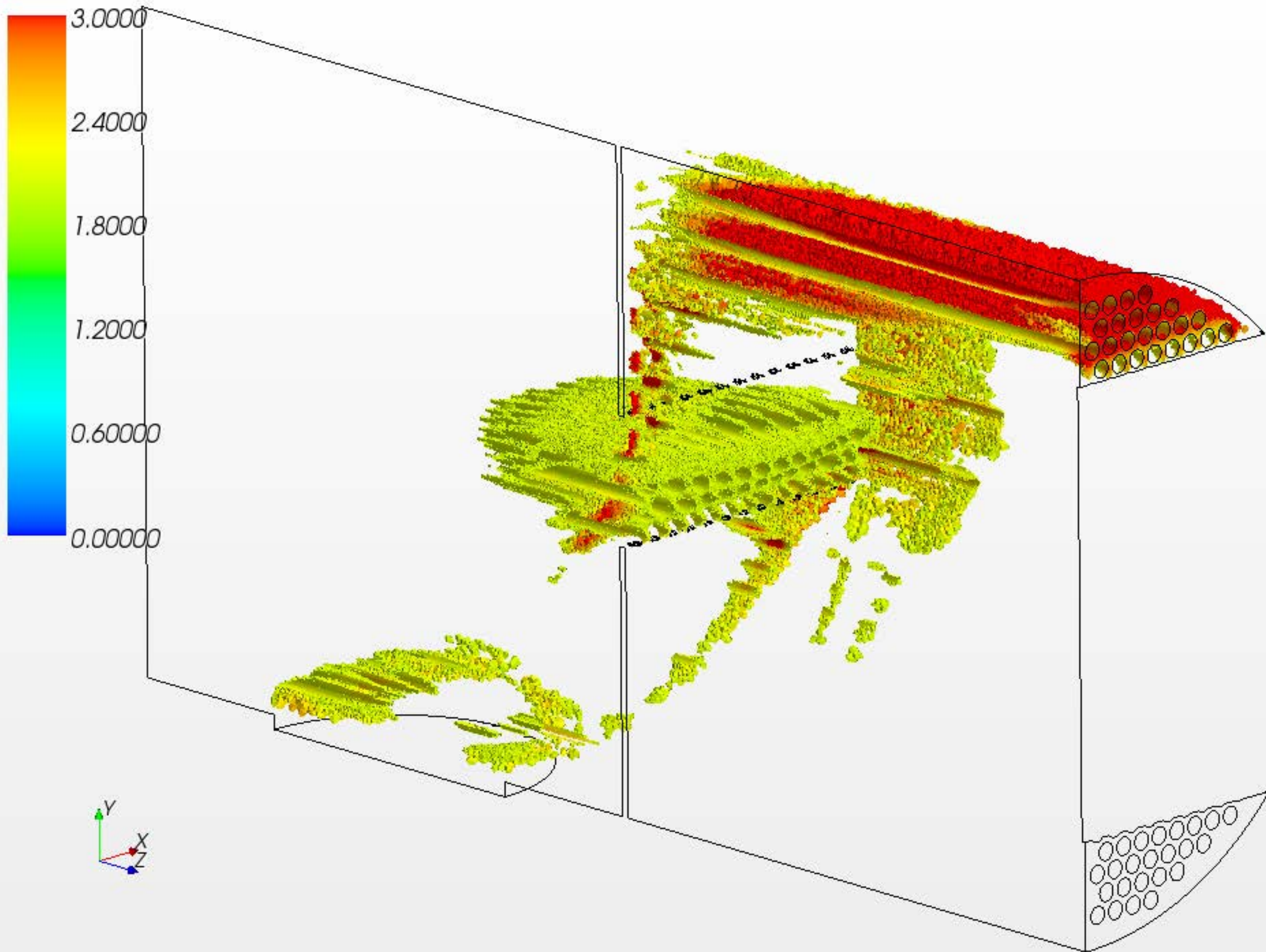

Velocity: Magnitude (m/s)

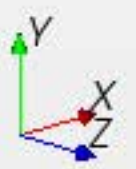
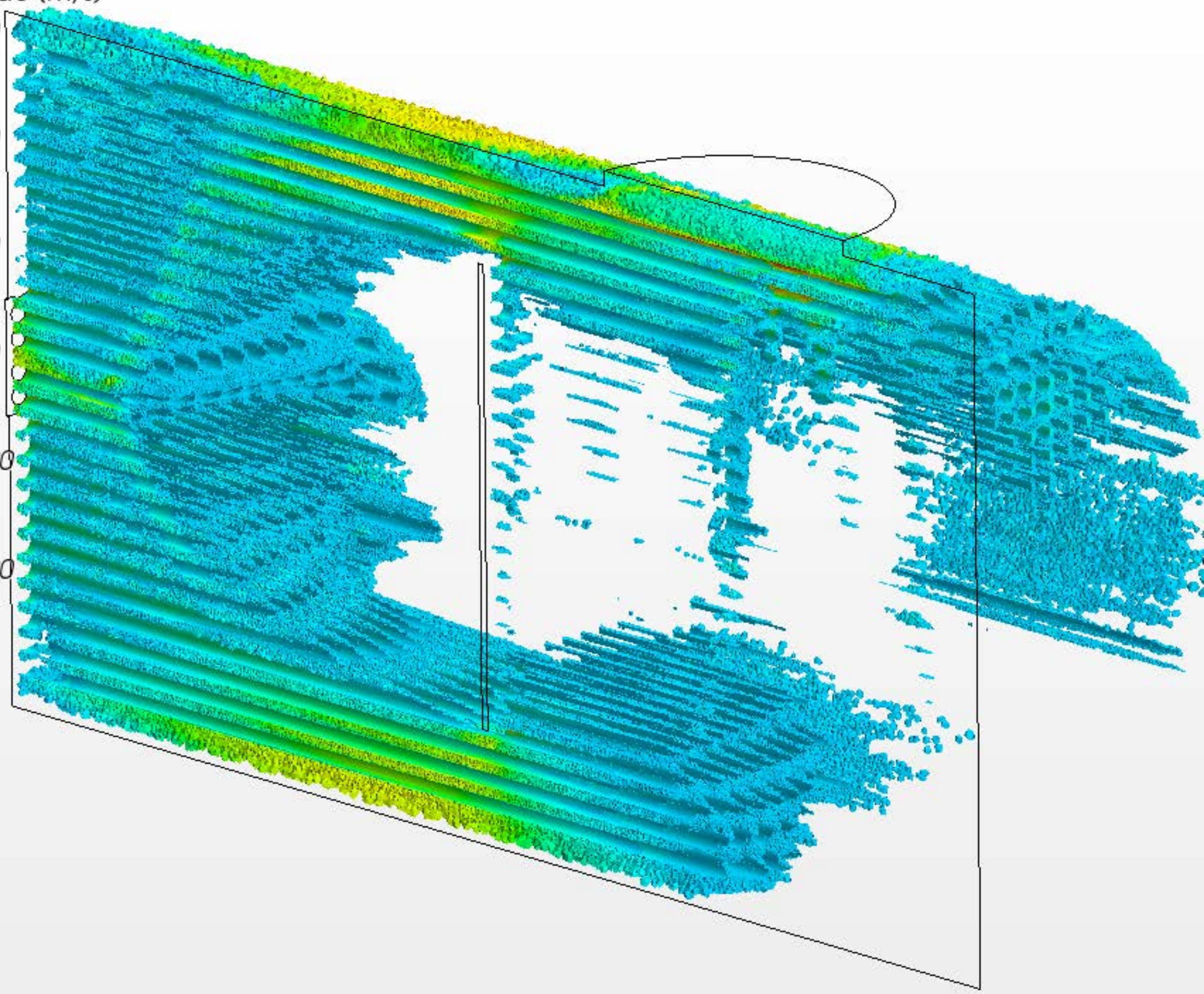
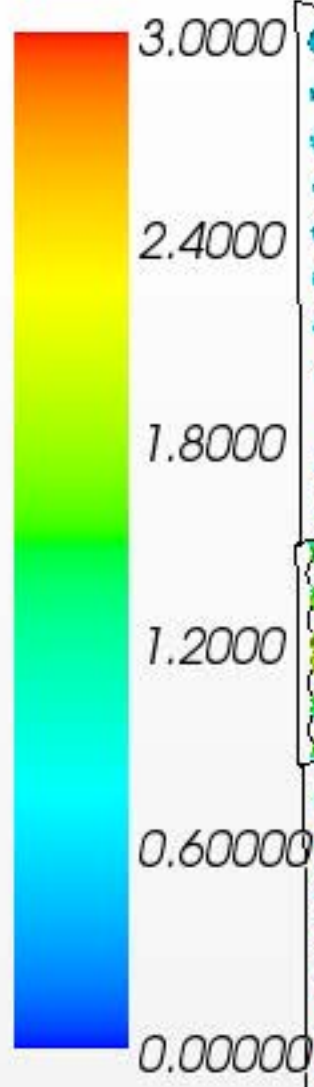

Velocity: Magnitude (m/s)

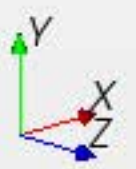
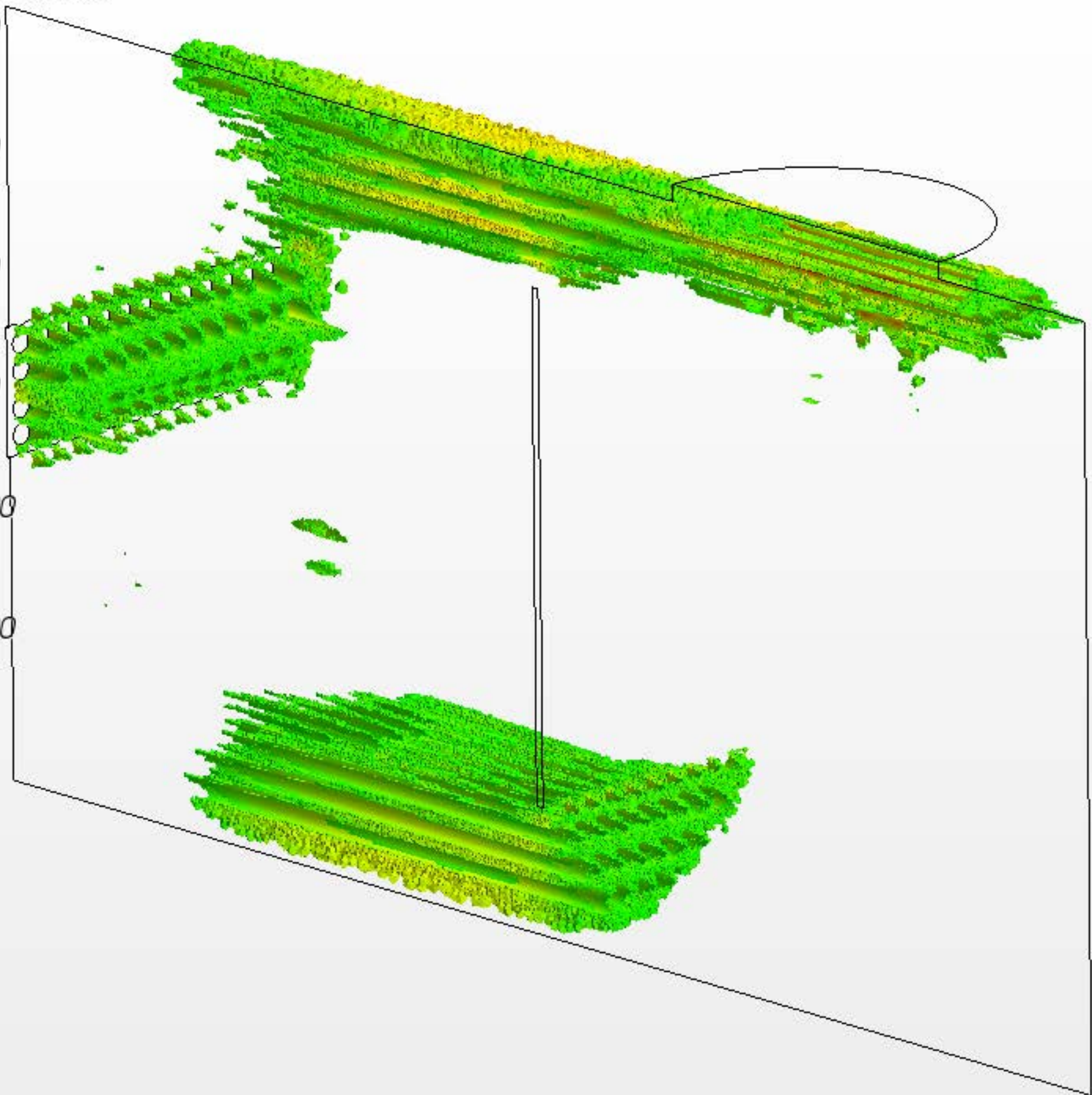
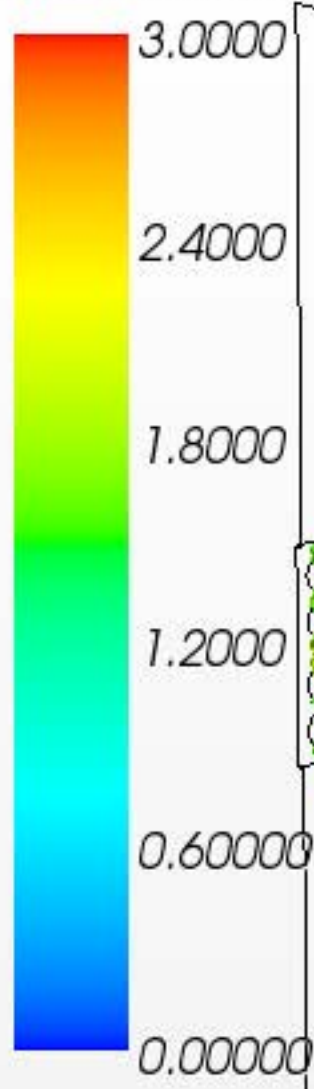

Velocity: Magnitude (m/s)

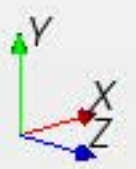
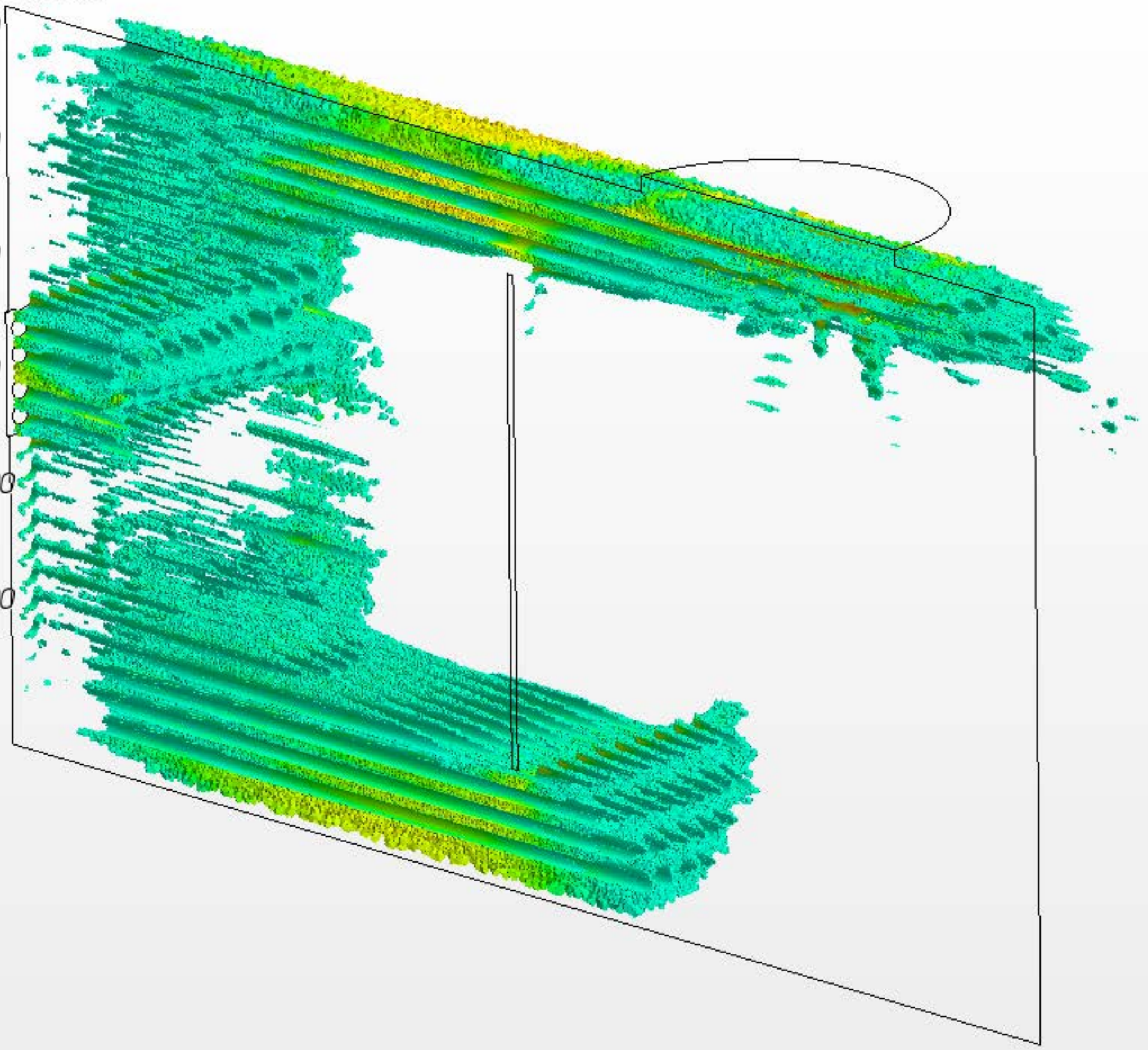
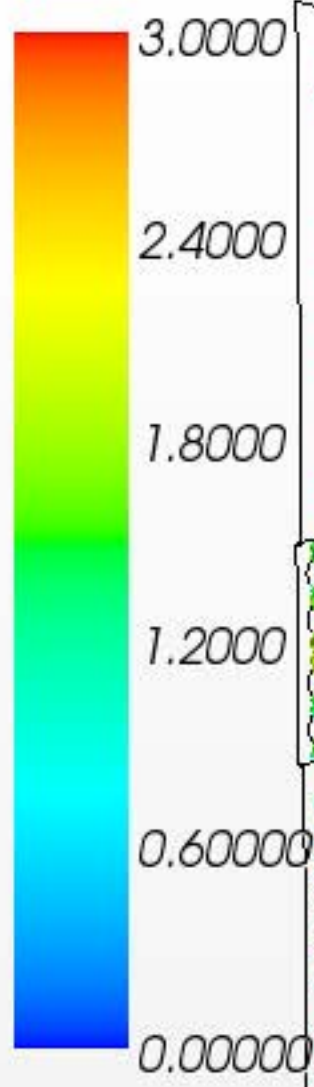

Velocity: Magnitude (m/s)

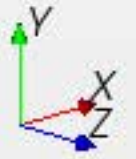
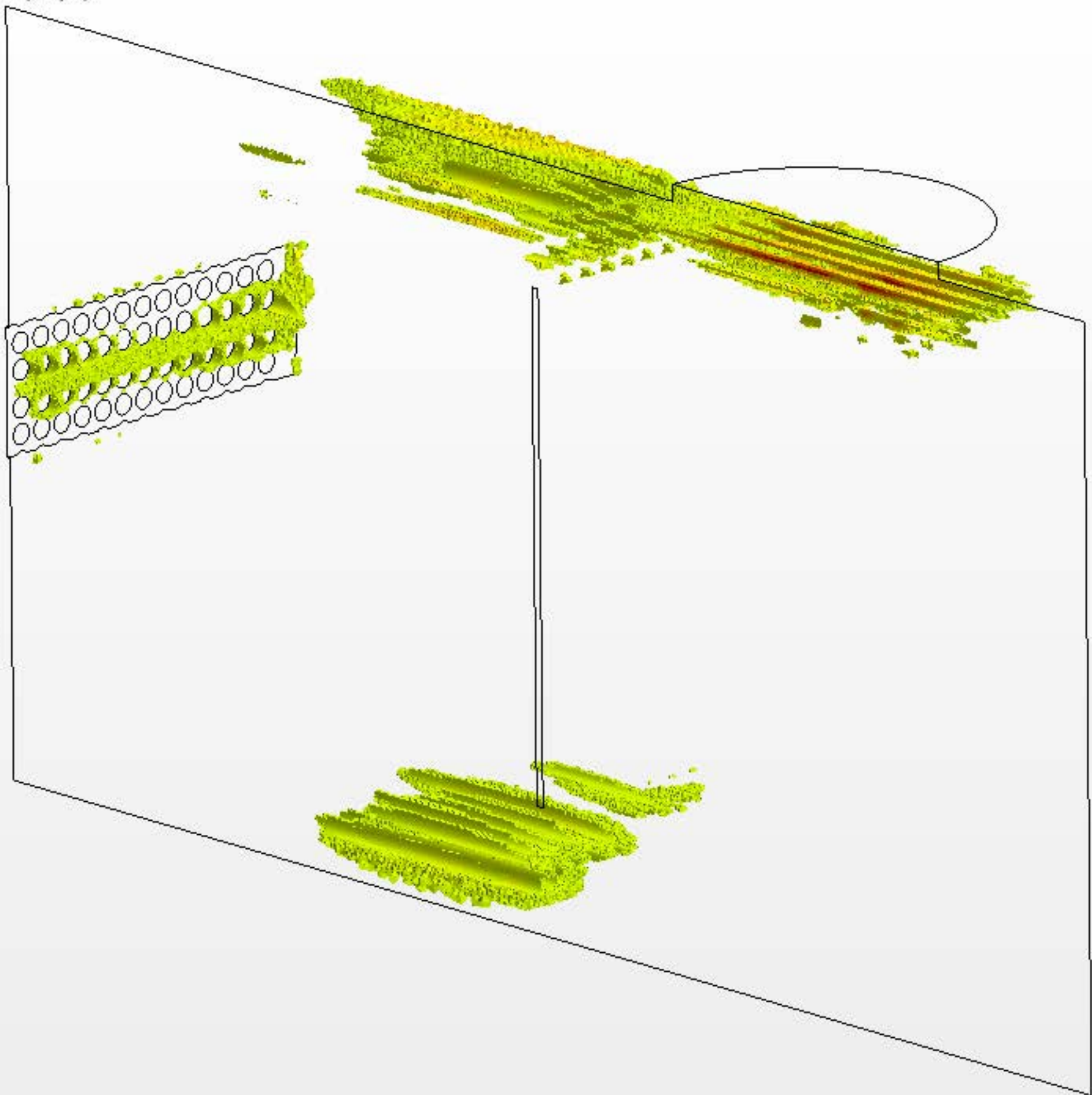
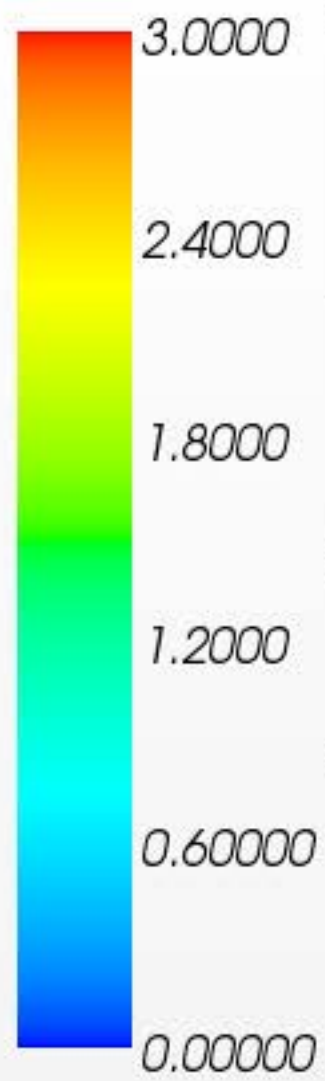

Velocity: Magnitude (m/s)

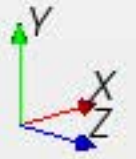
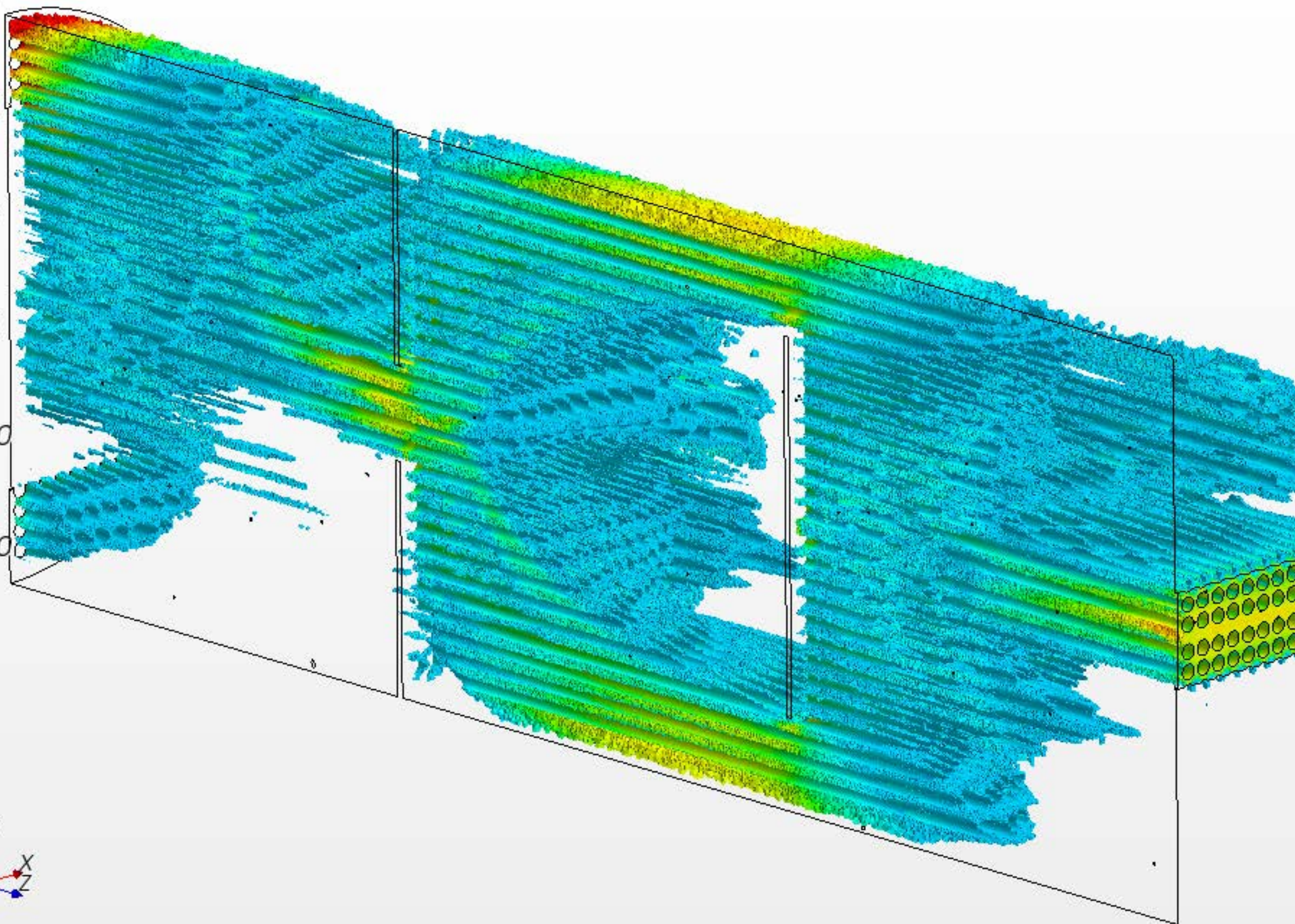
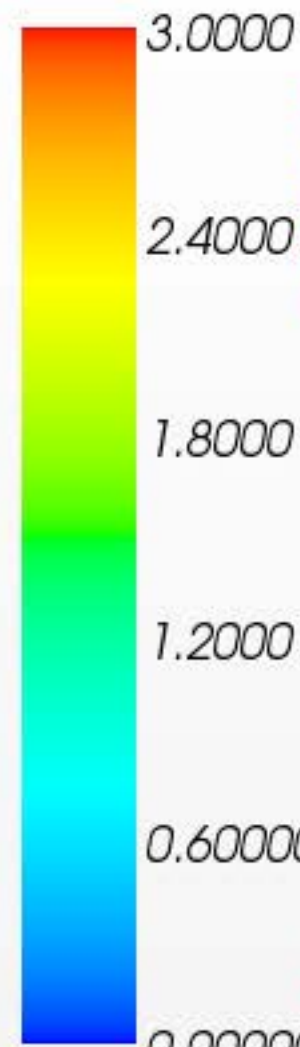

Velocity: Magnitude (m/s)

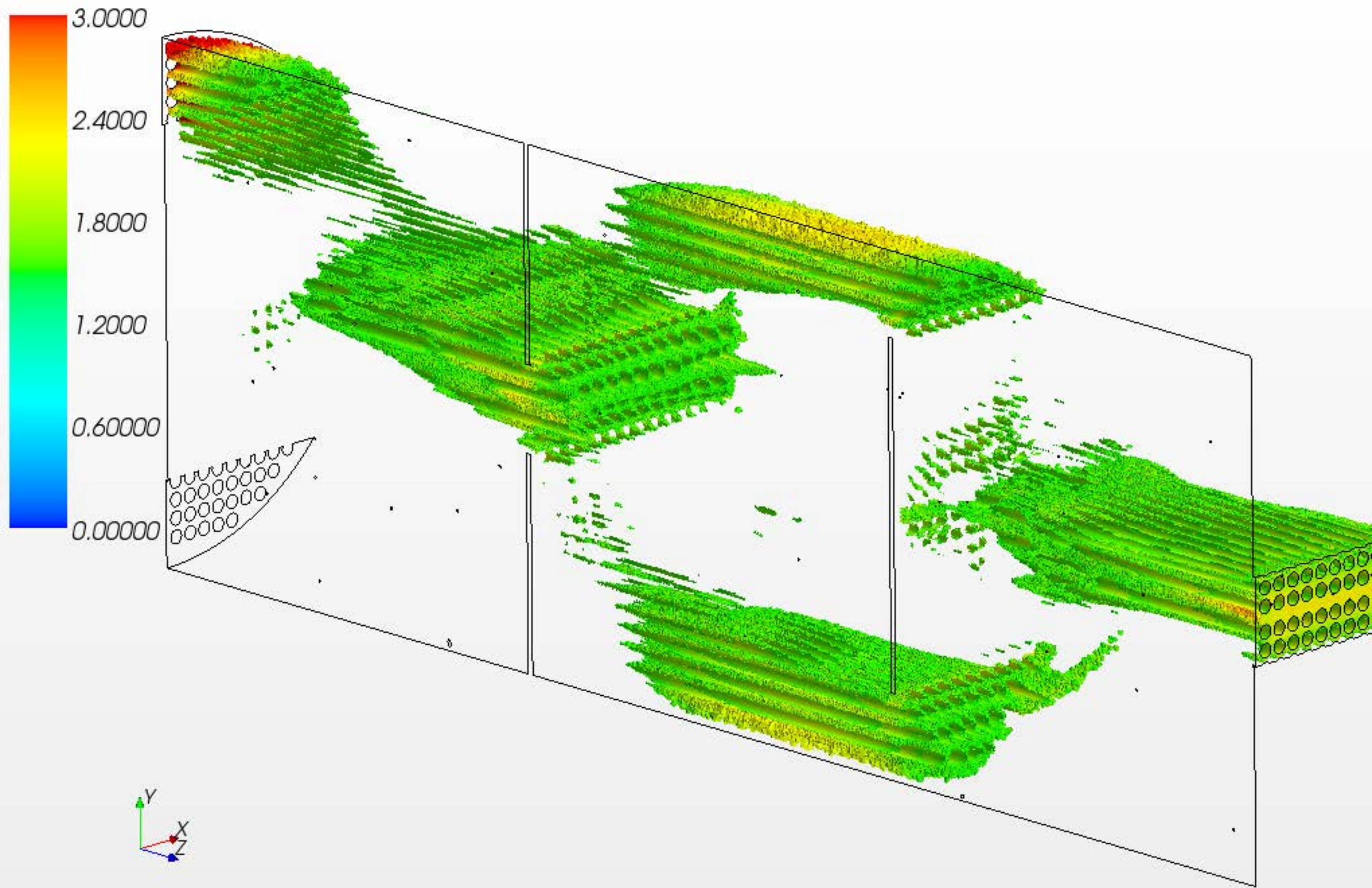

Velocity: Magnitude (m/s)

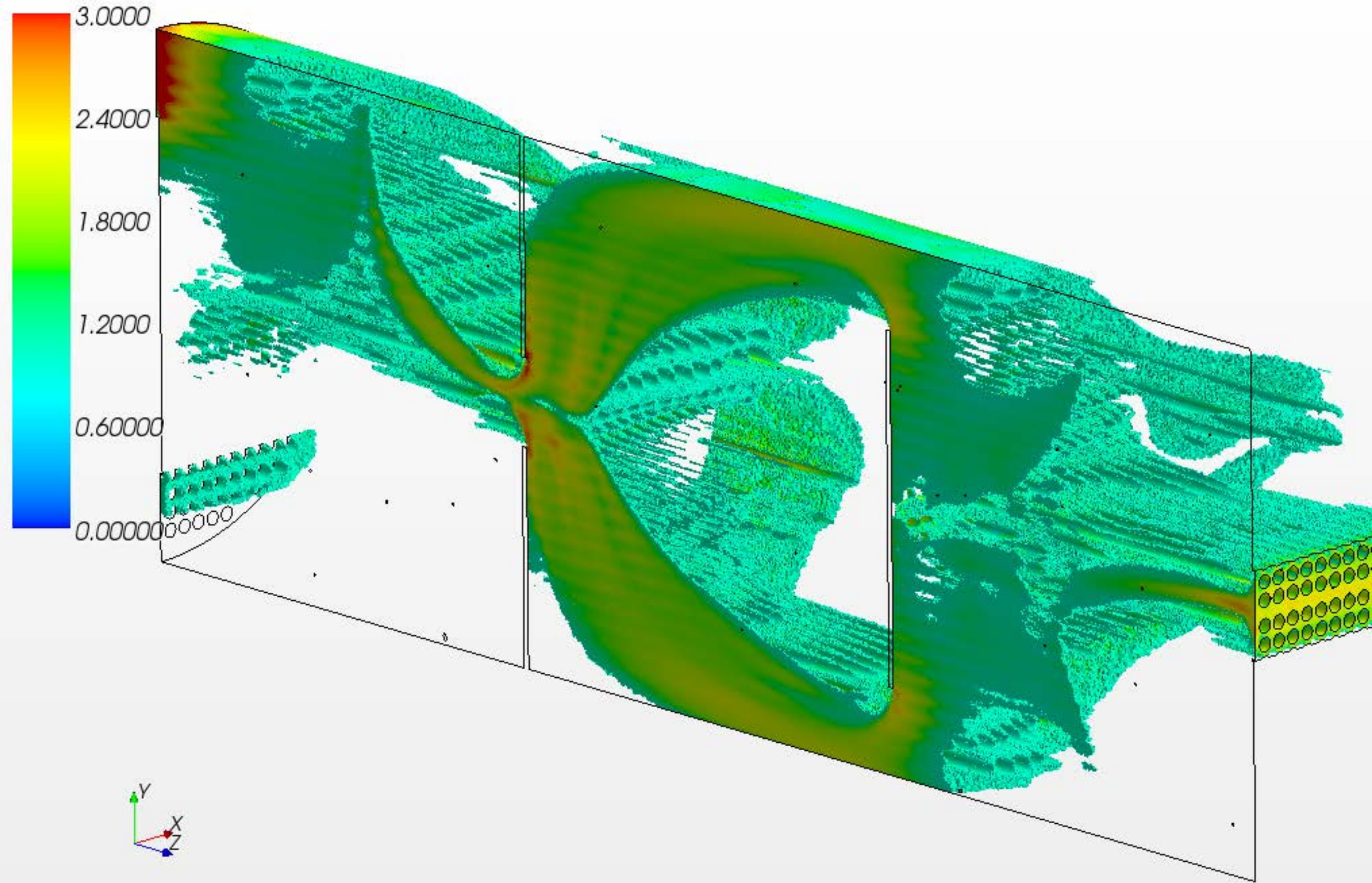

Velocity: Magnitude (m/s)

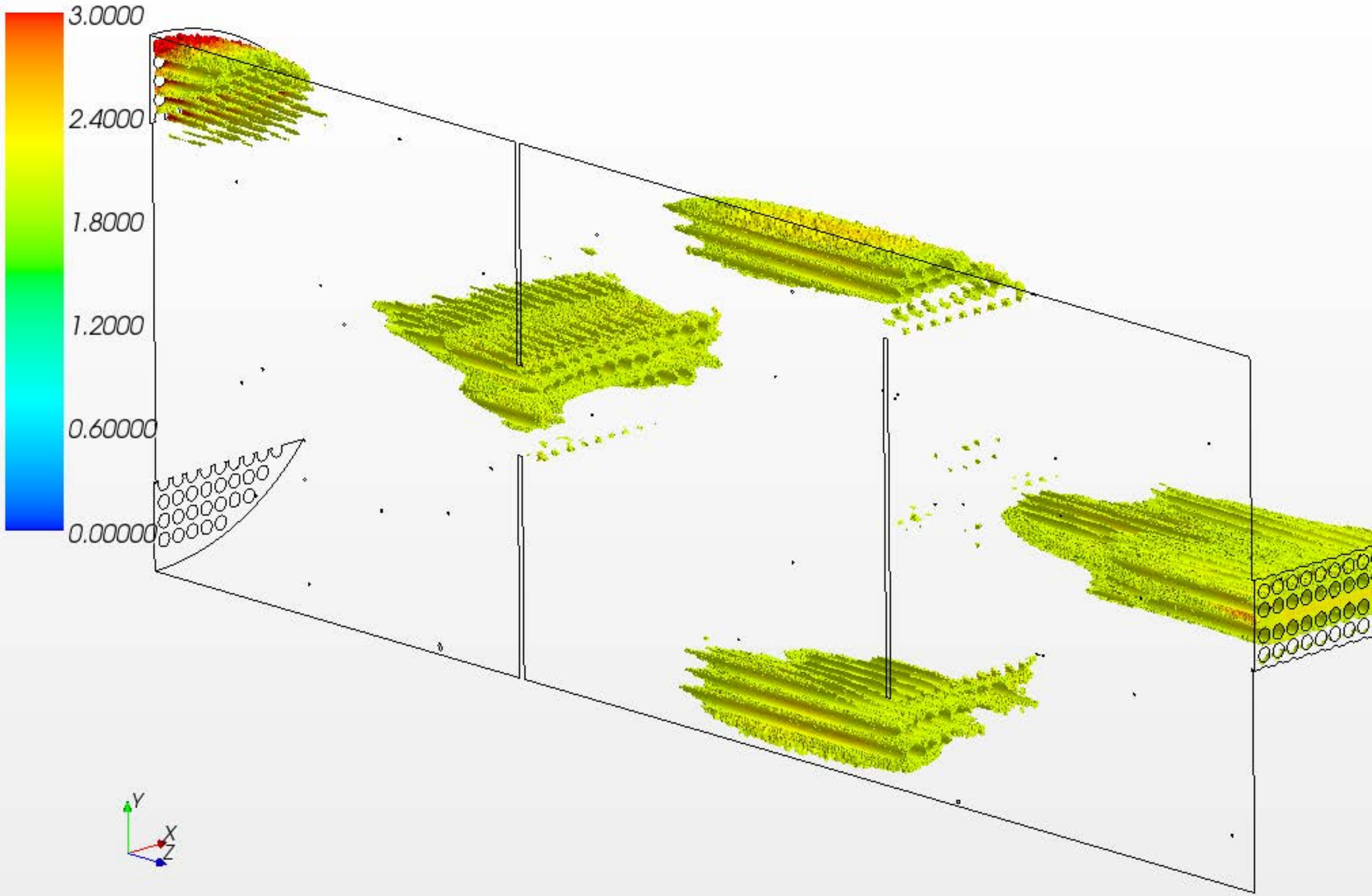

city: Magnitude (m/s)

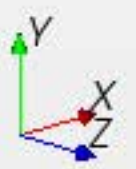
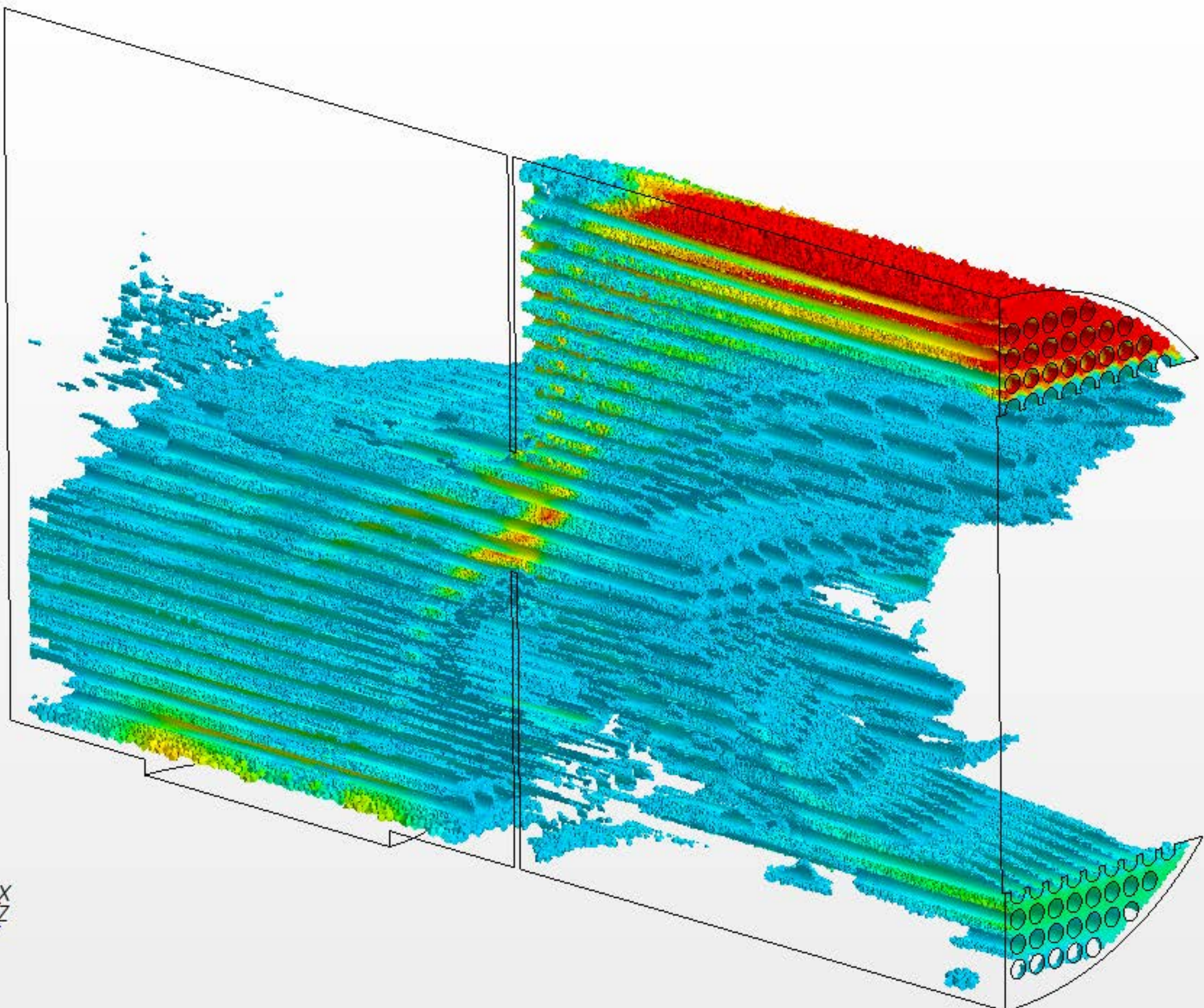
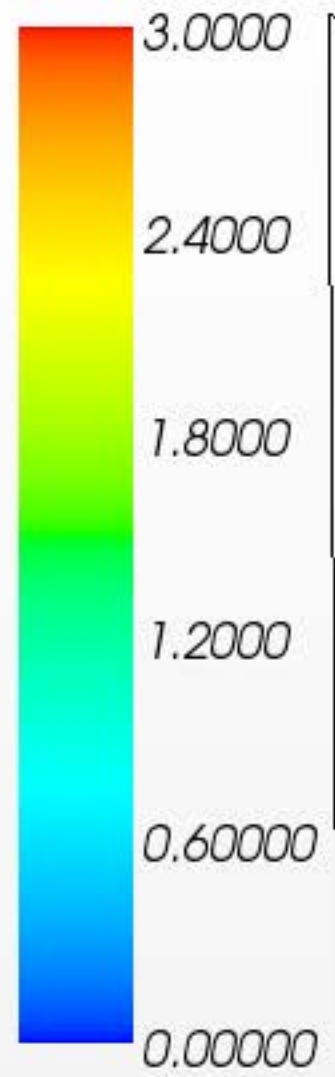

Velocity: Magnitude (m/s)

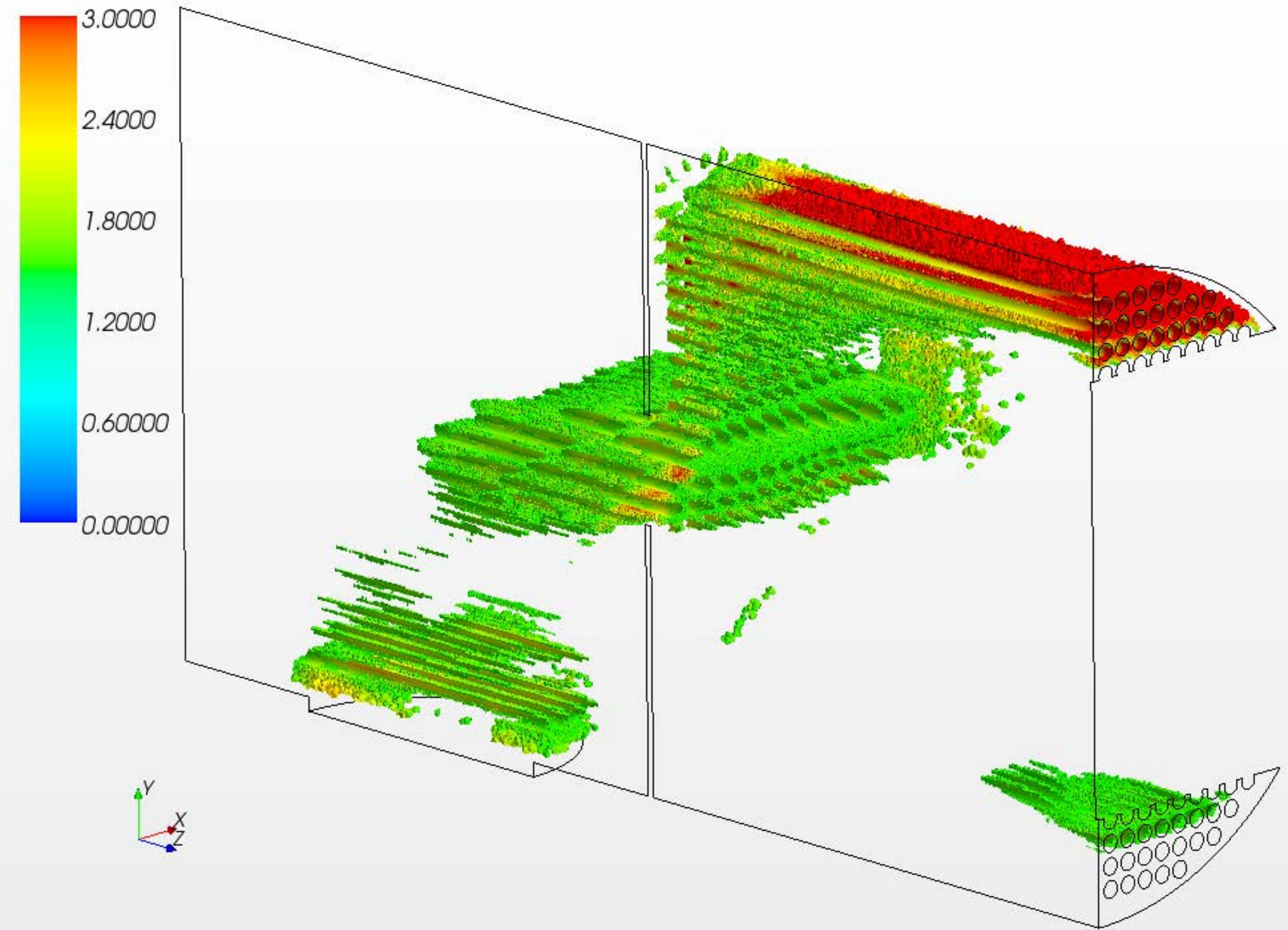

city: Magnitude (m/s)

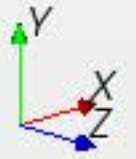
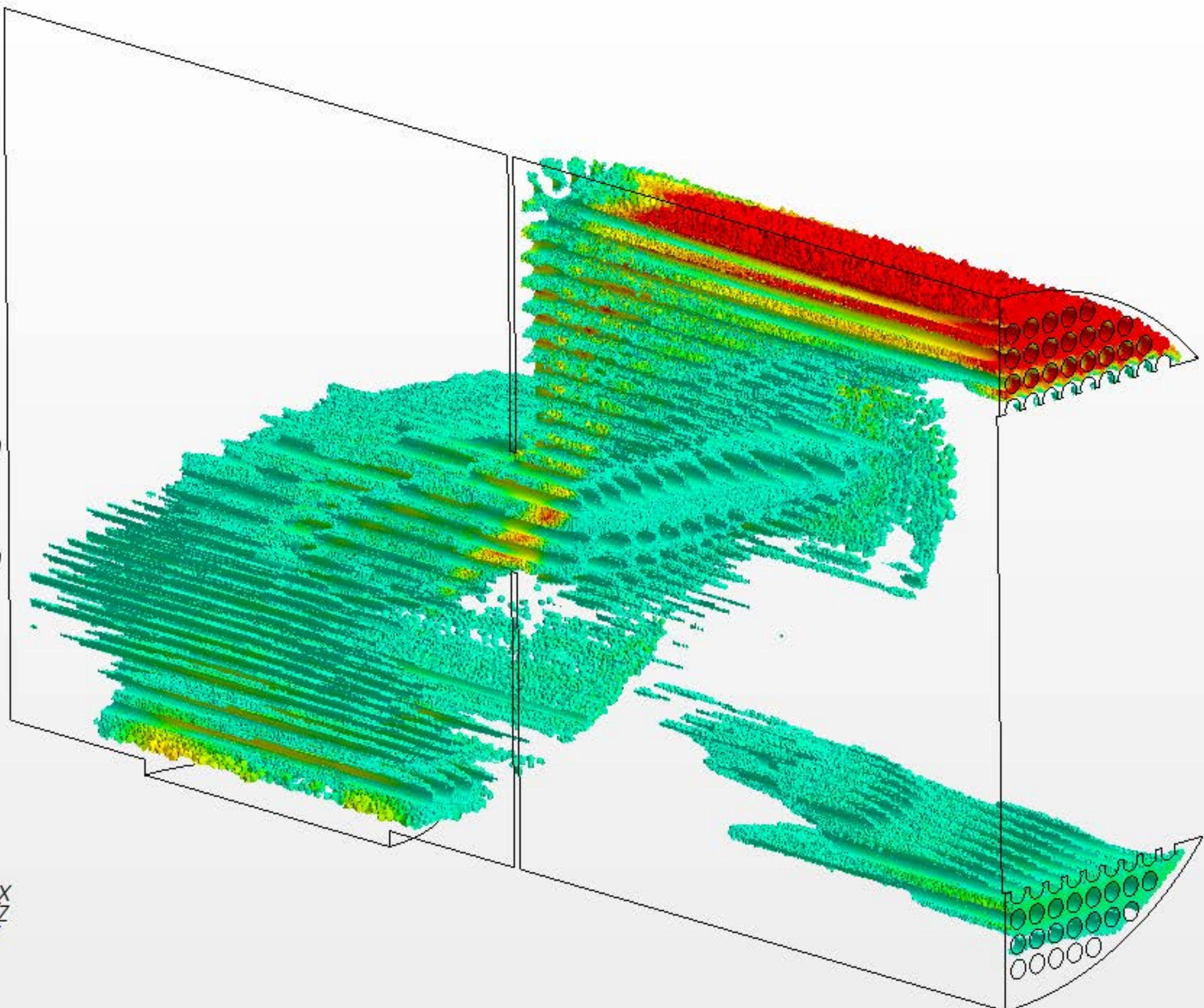
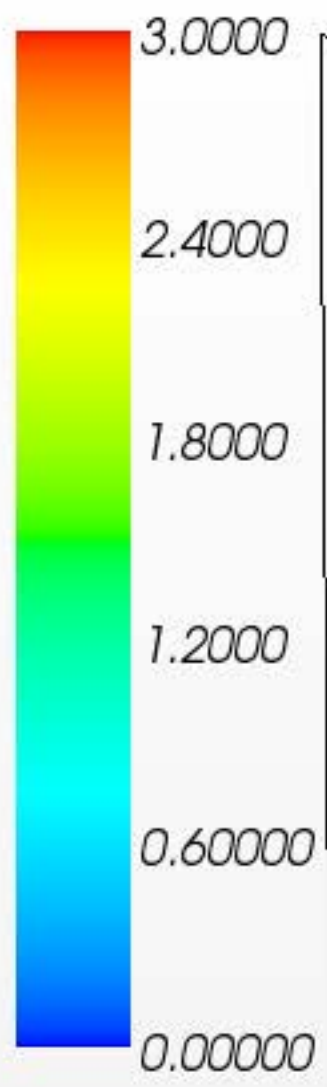

Velocity: Magnitude (m/s)

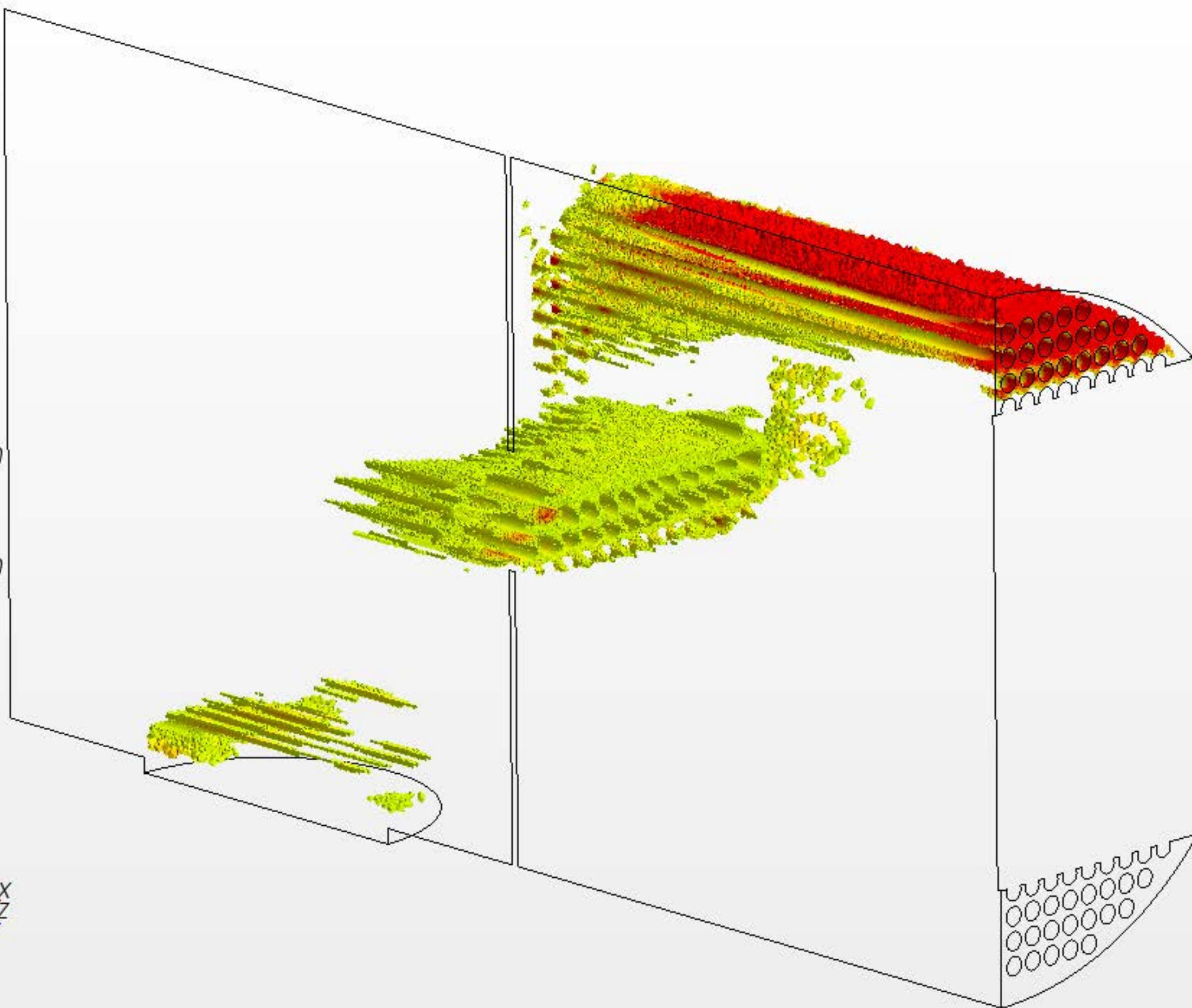
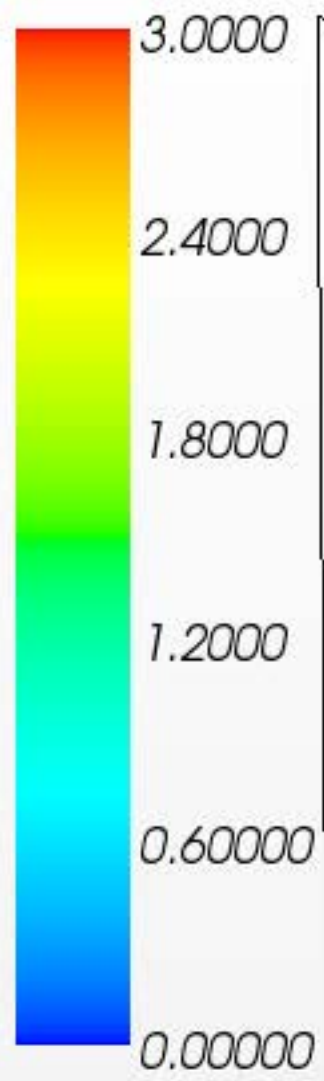

Velocity: Magnitude (m/s)

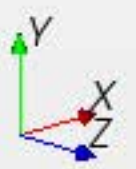
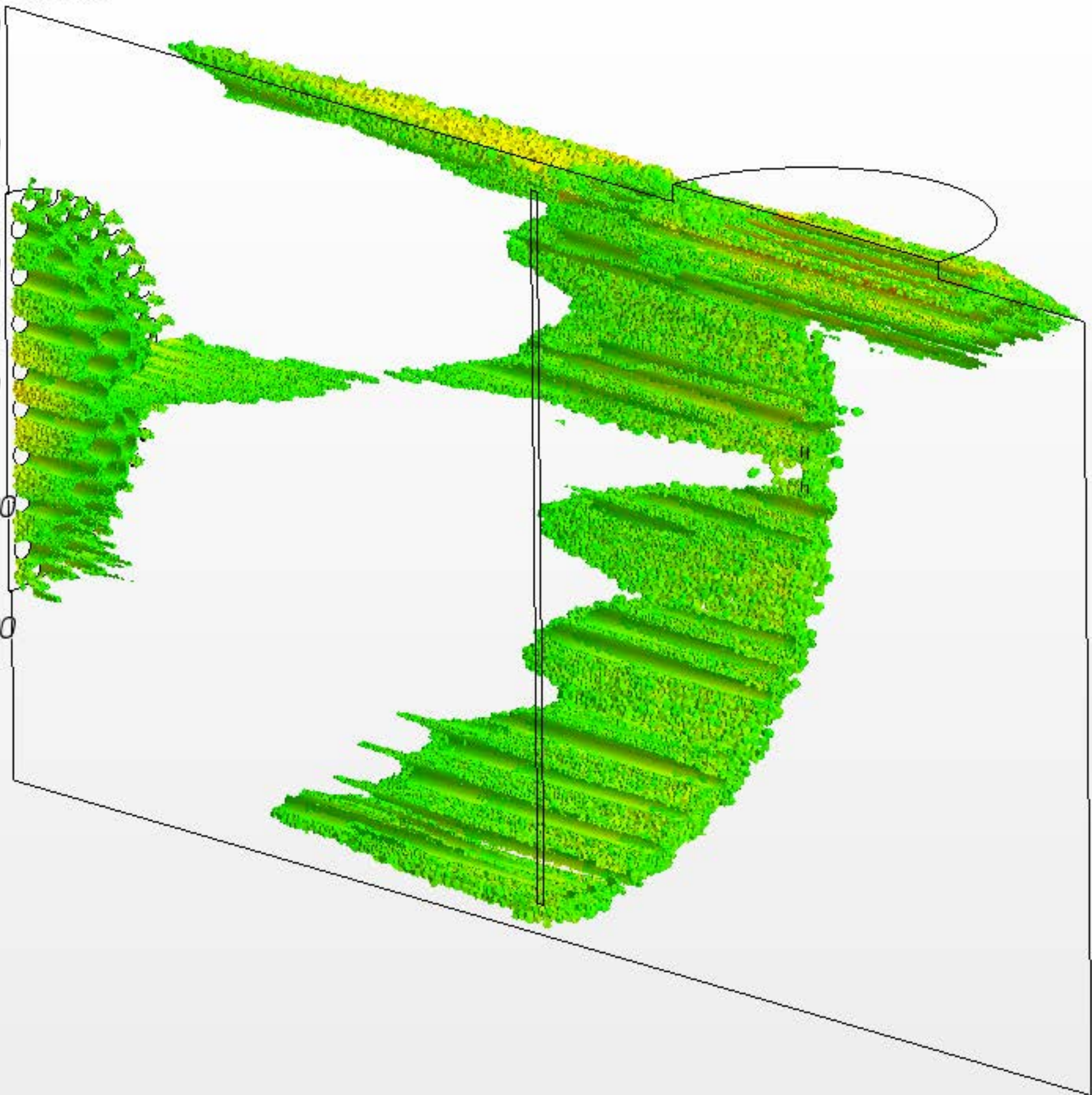
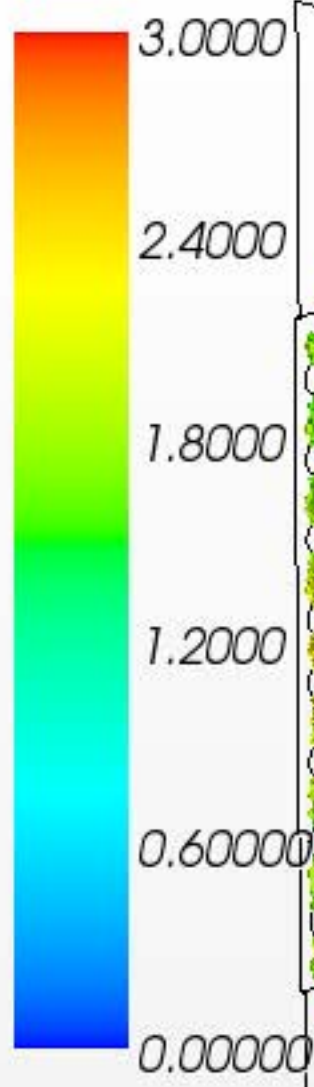

Velocity: Magnitude (m/s)

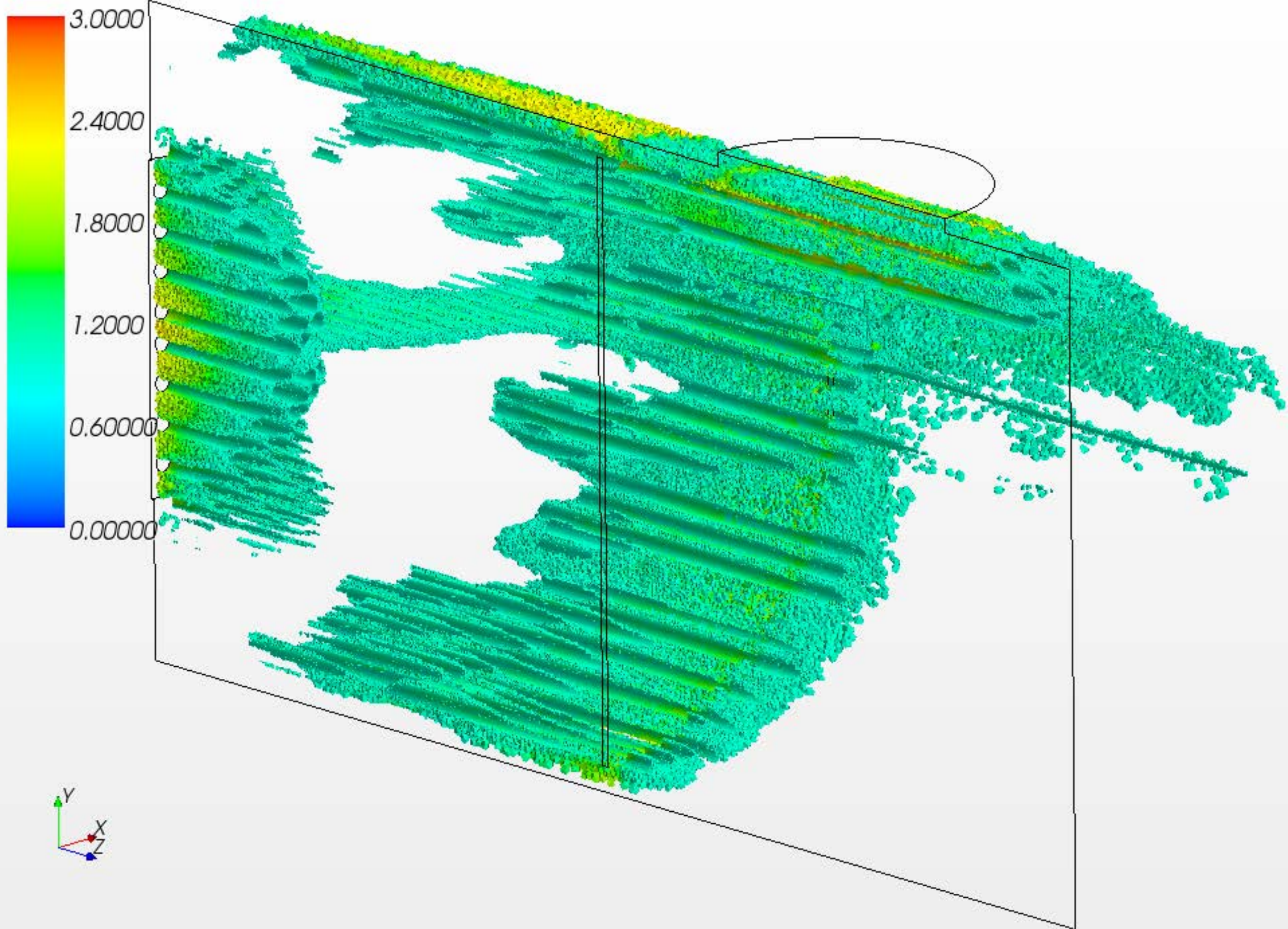

Velocity: Magnitude (m/s)

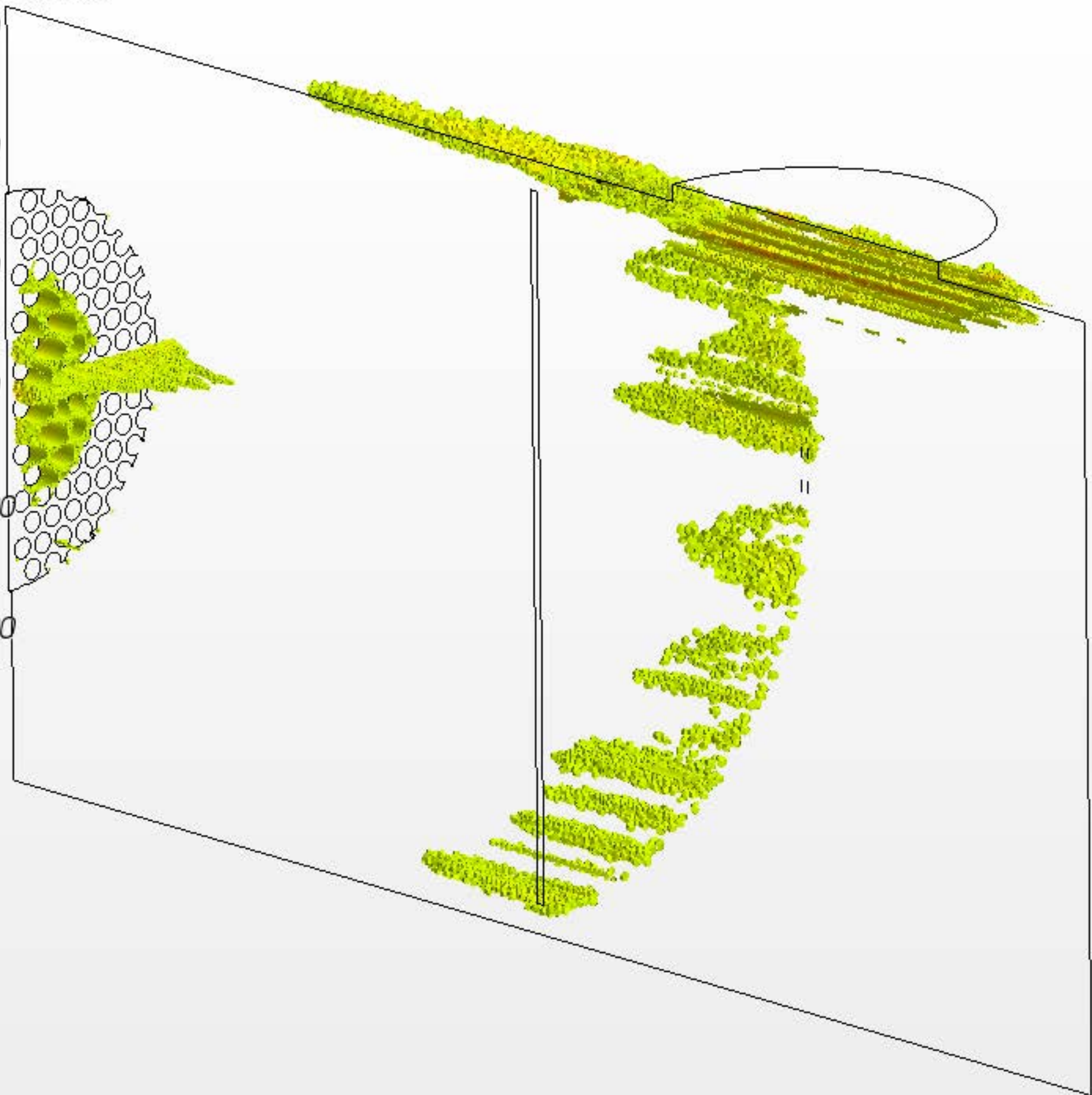
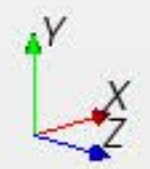
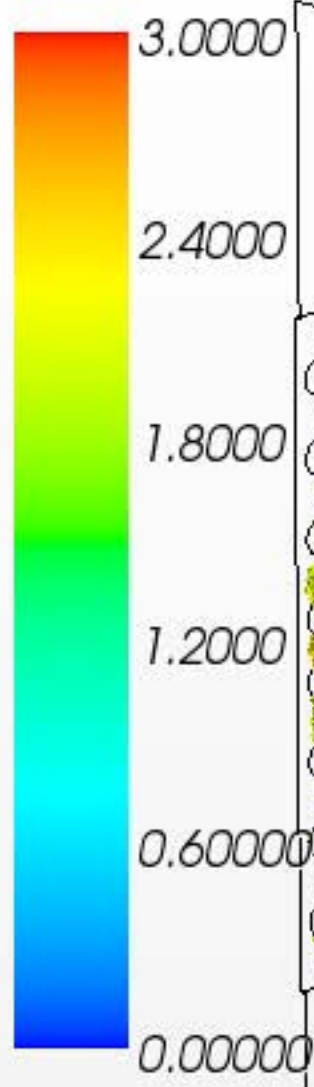

Velocity: Magnitude (m/s)

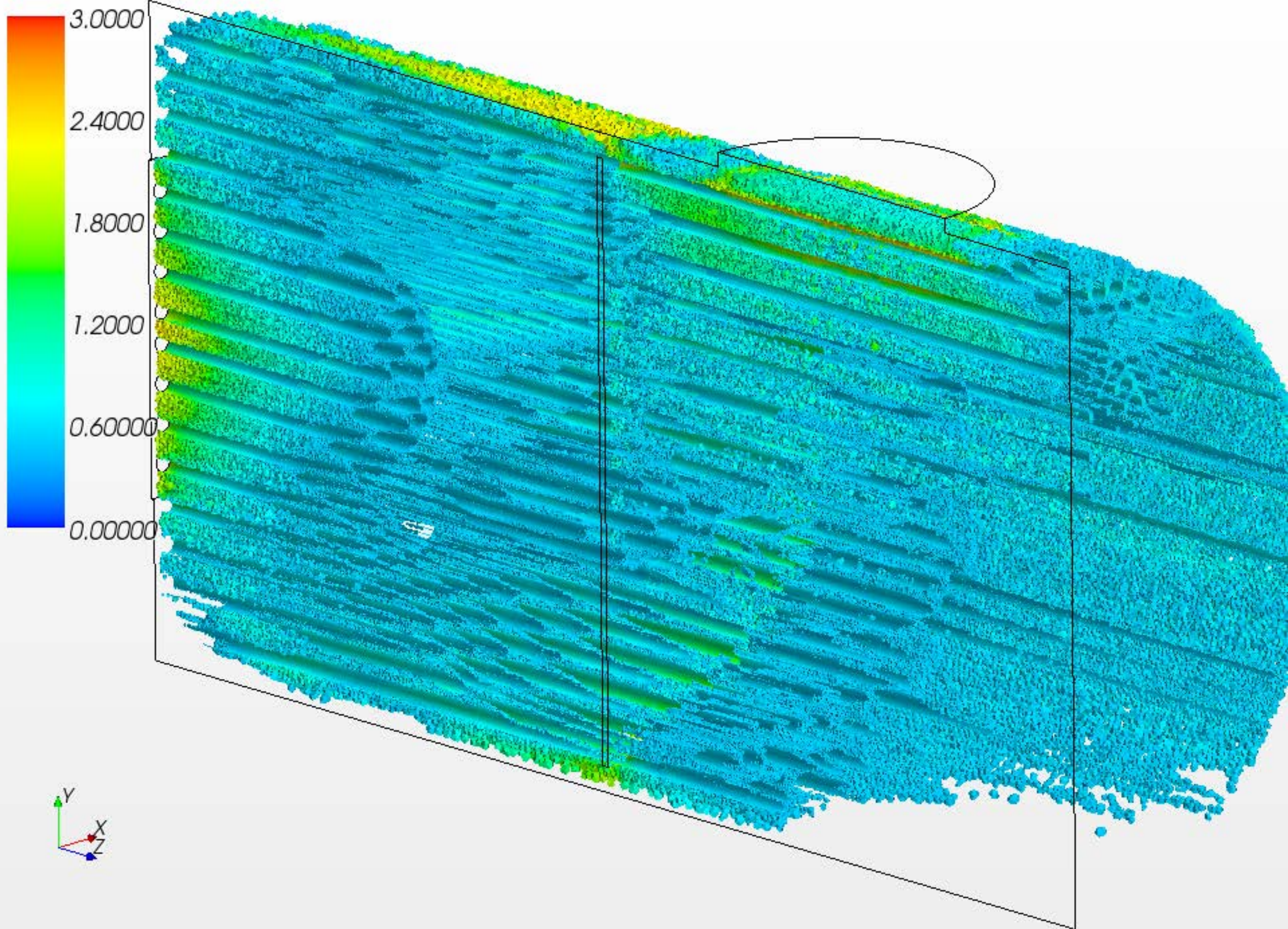

Velocity: Magnitude (m/s)

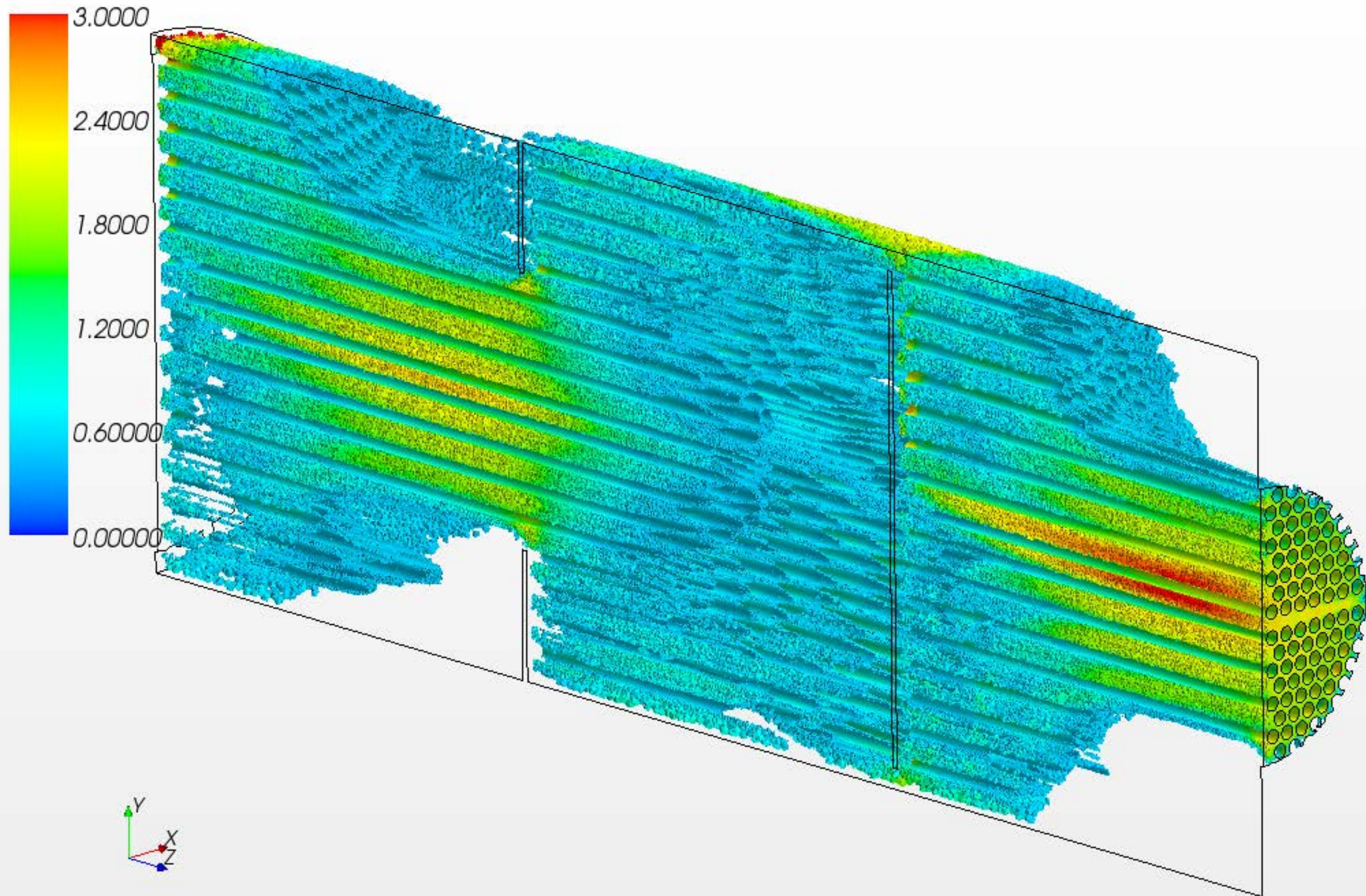

Velocity: Magnitude (m/s)

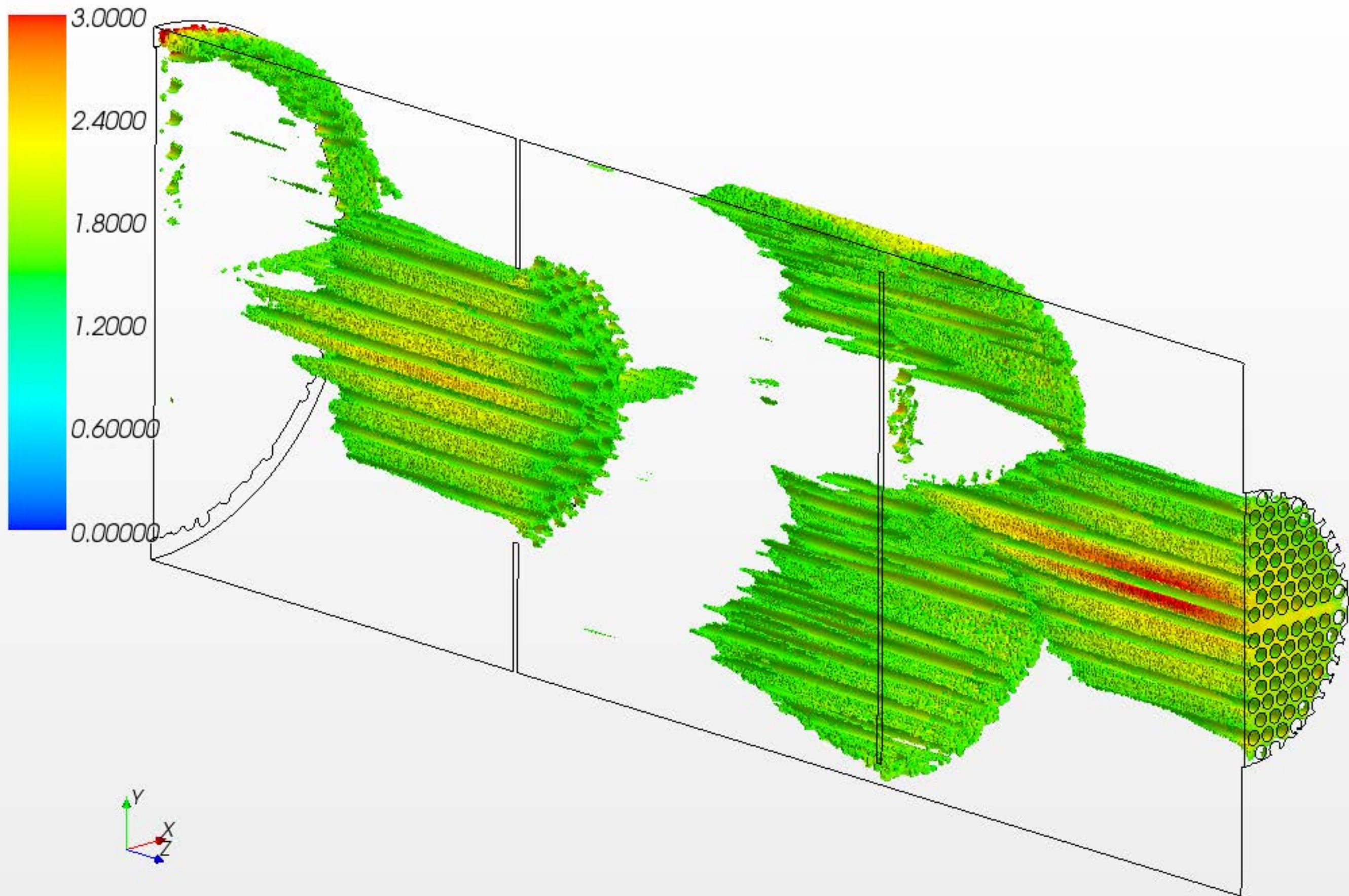

Velocity: Magnitude (m/s)

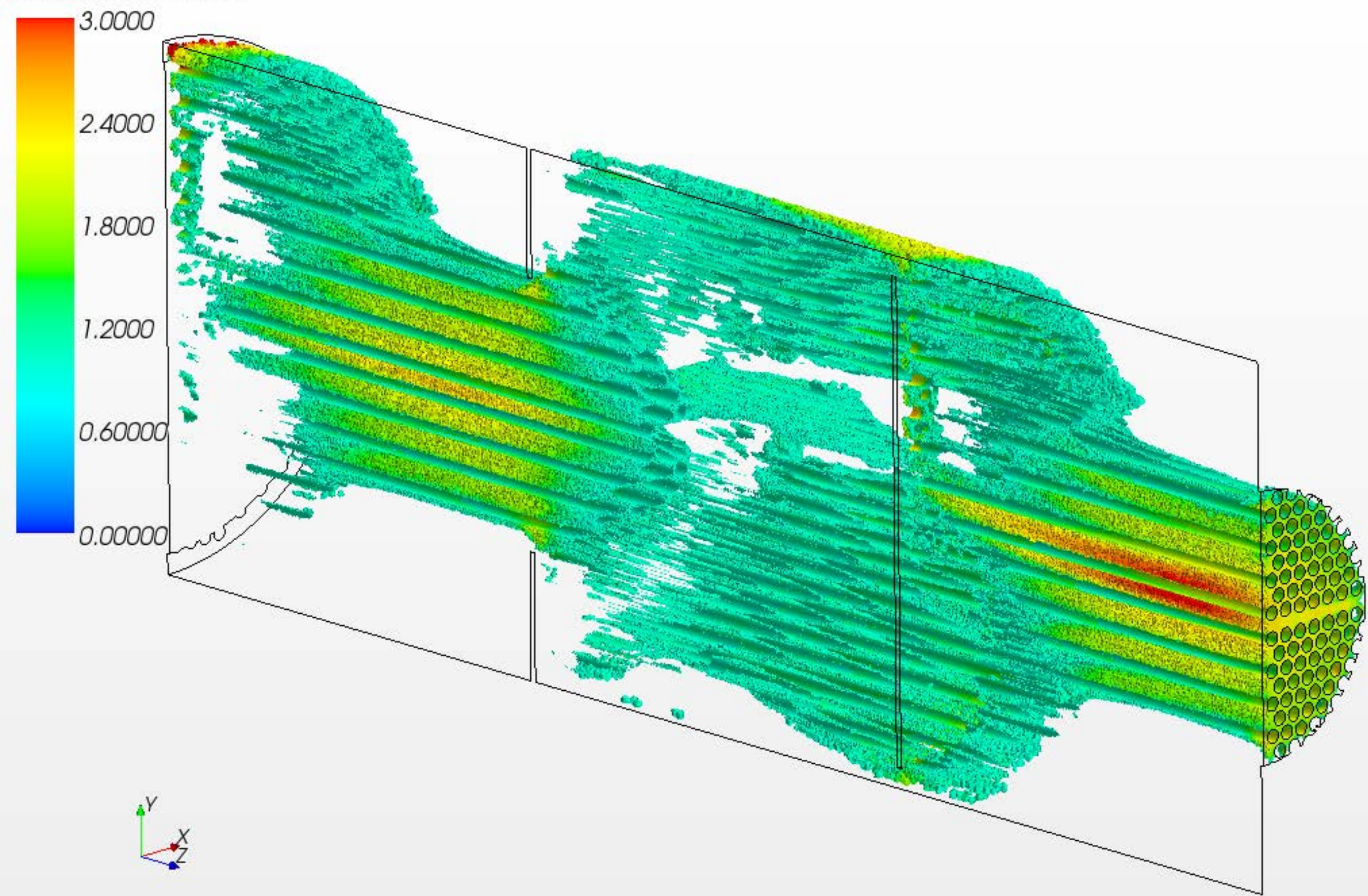

Velocity: Magnitude (m/s)

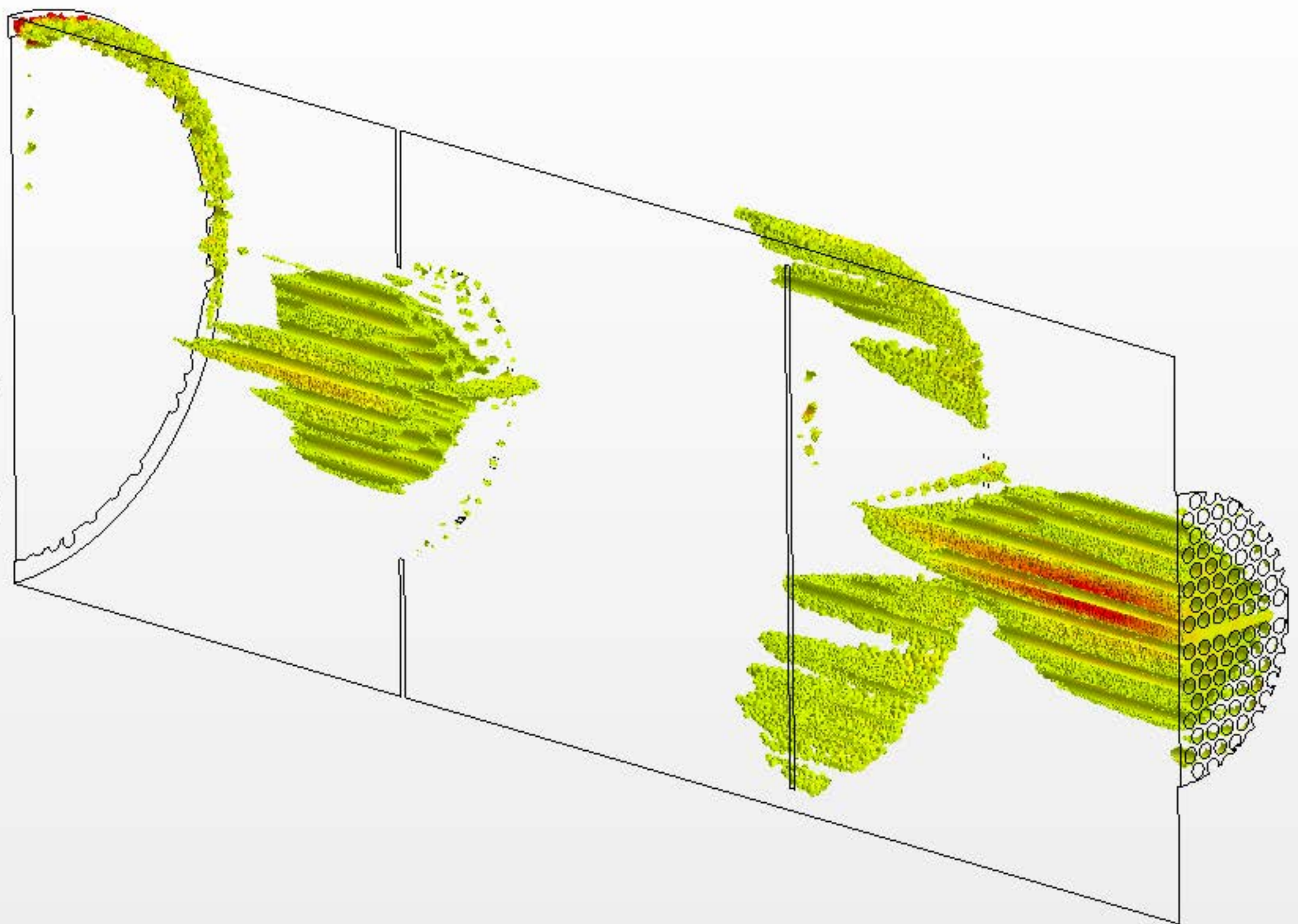
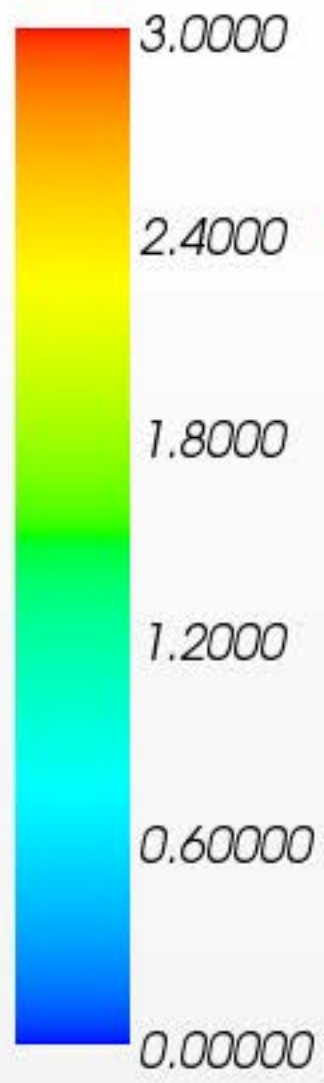

Velocity: Magnitude (m/s)

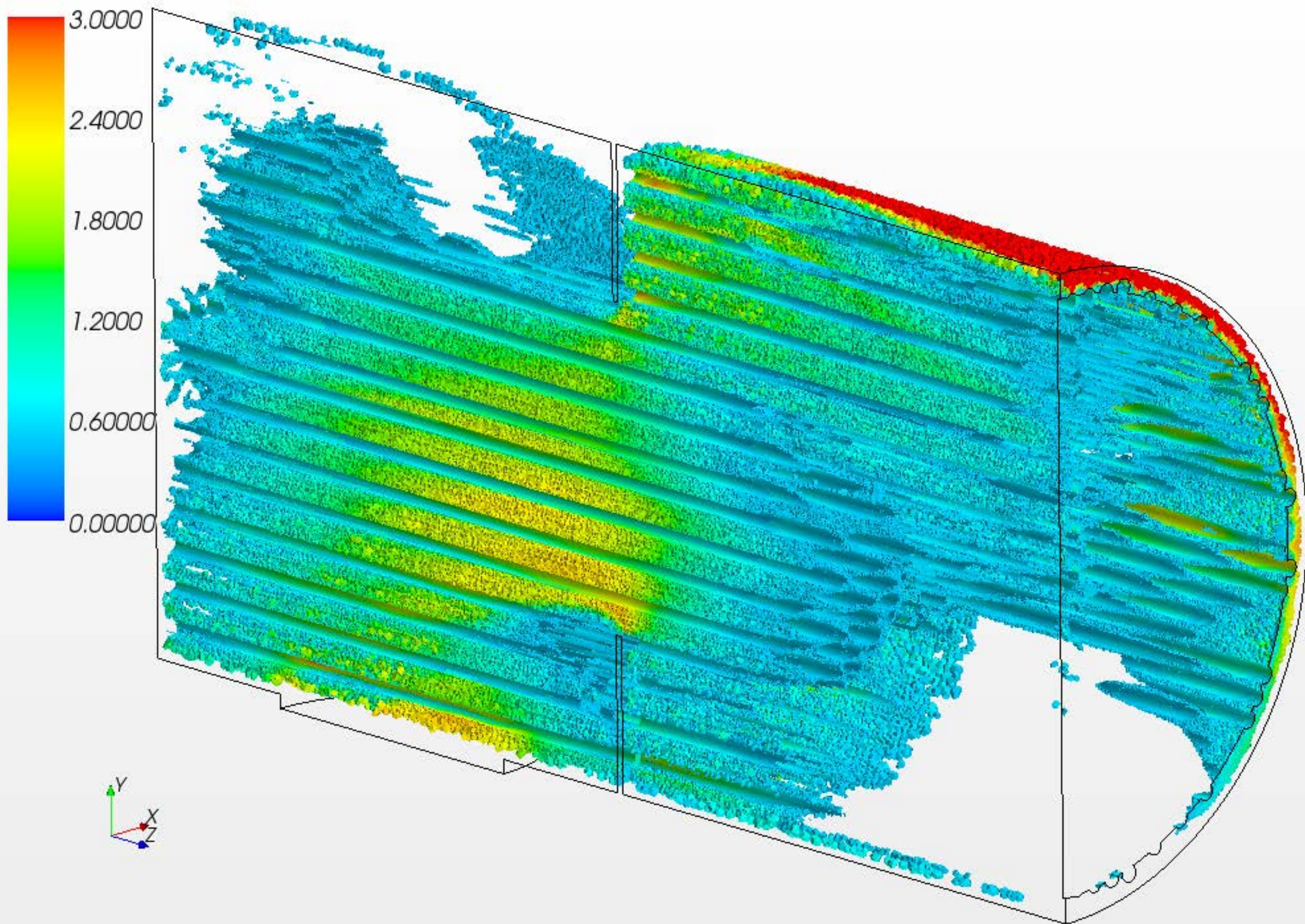

Velocity: Magnitude (m/s)

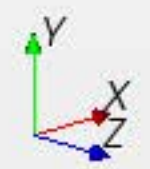
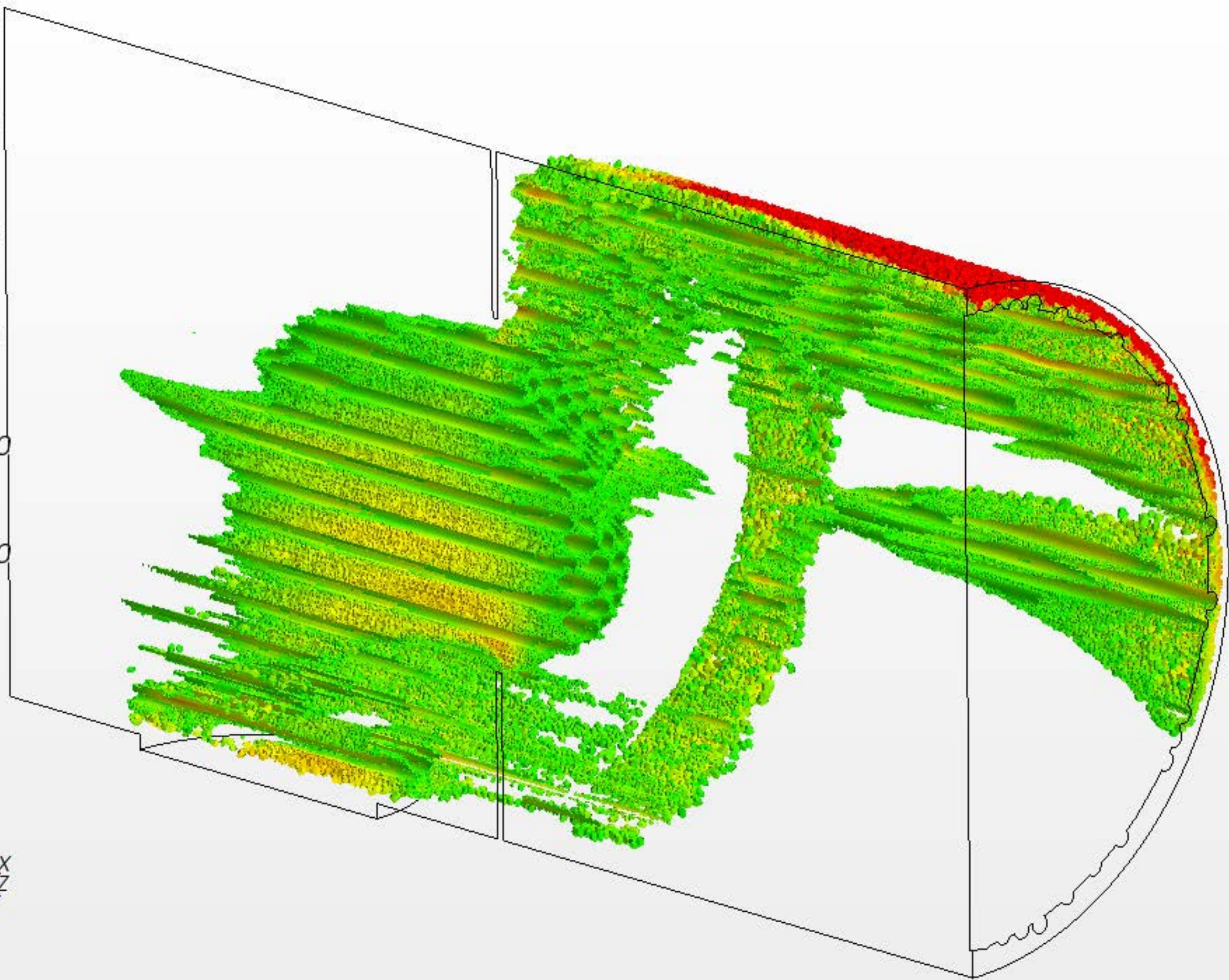
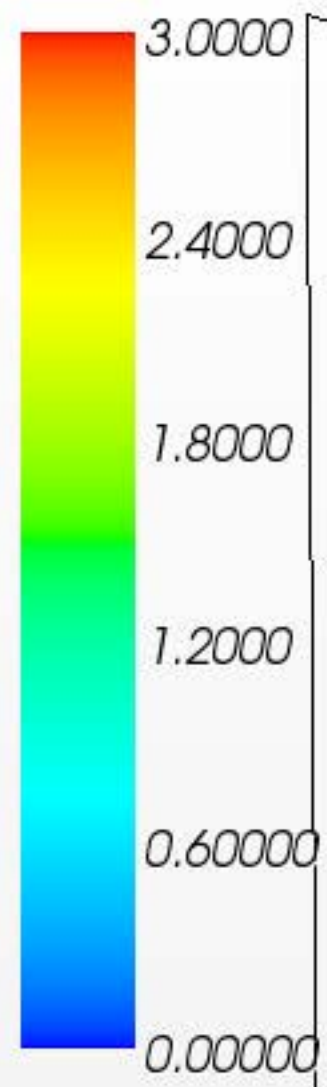

city: Magnitude (m/s)

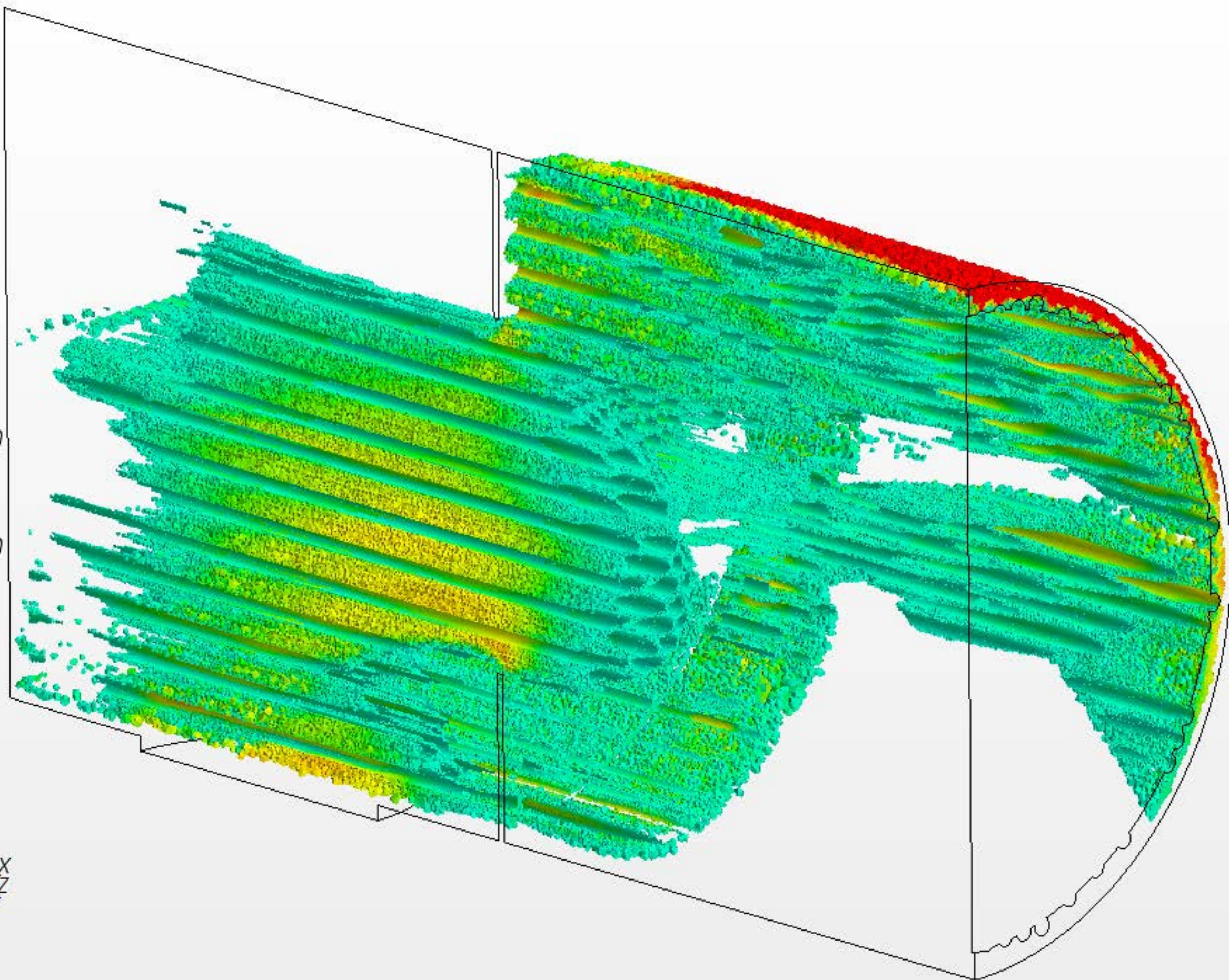
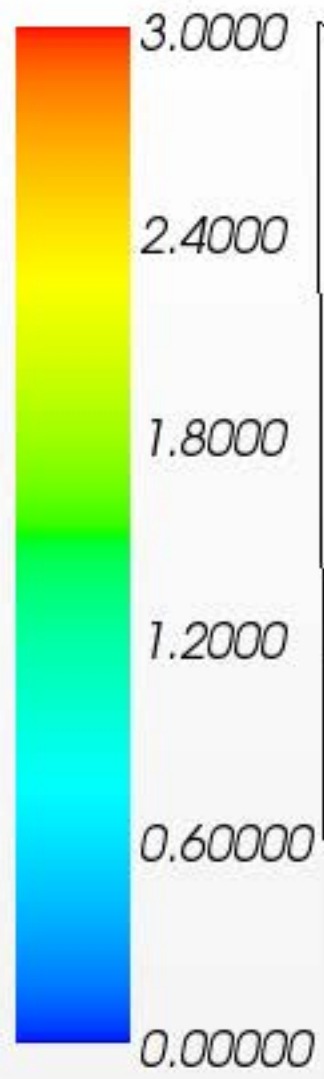

Velocity: Magnitude (m/s)

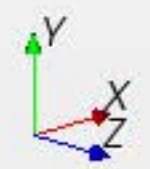
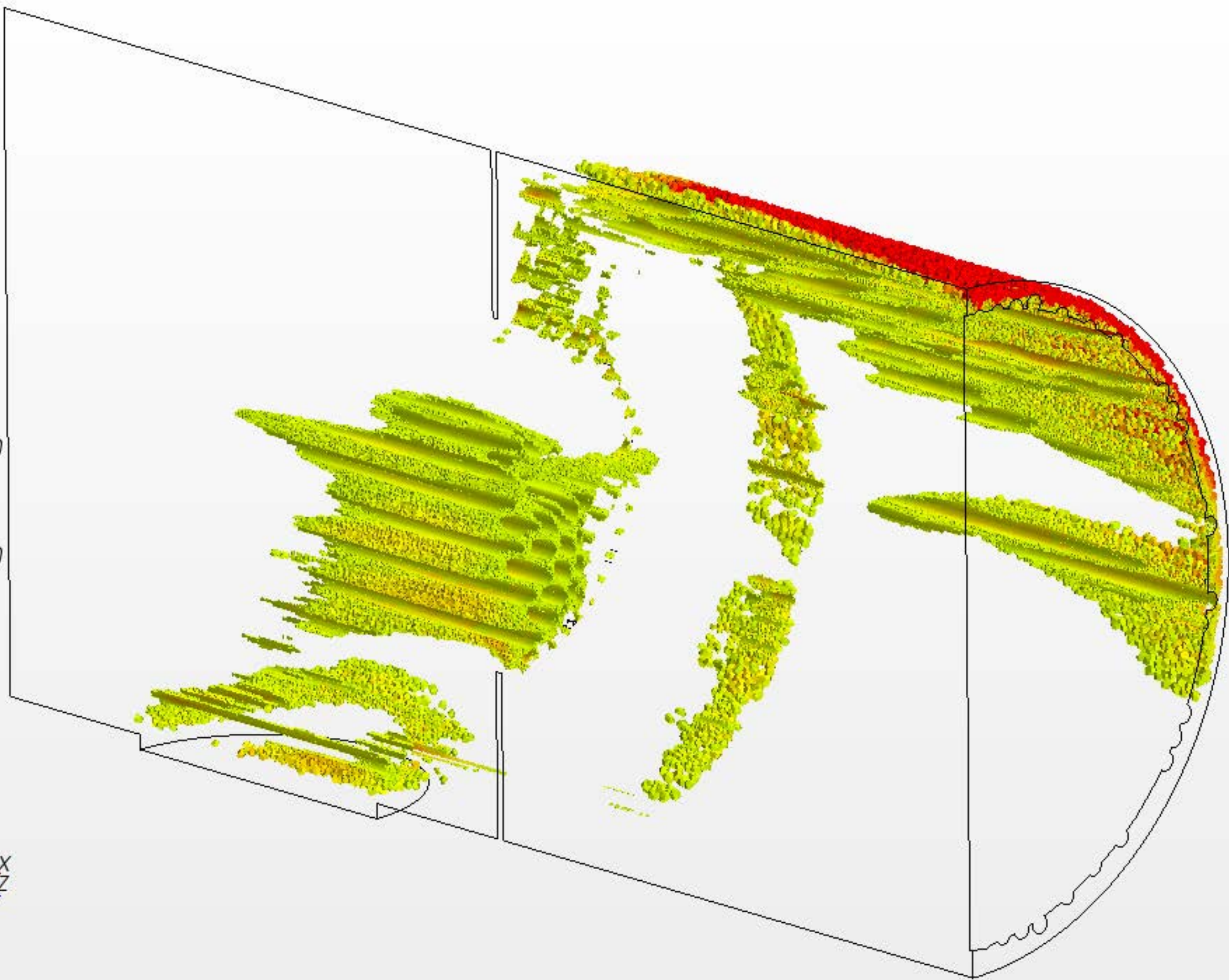
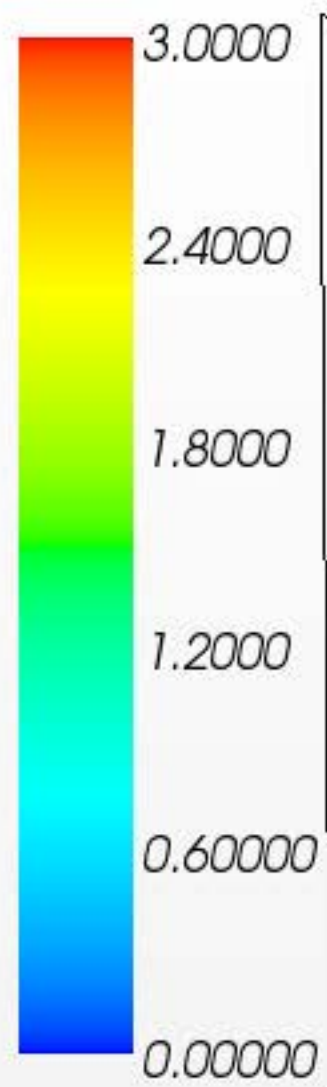

Velocity: Magnitude (m/s)

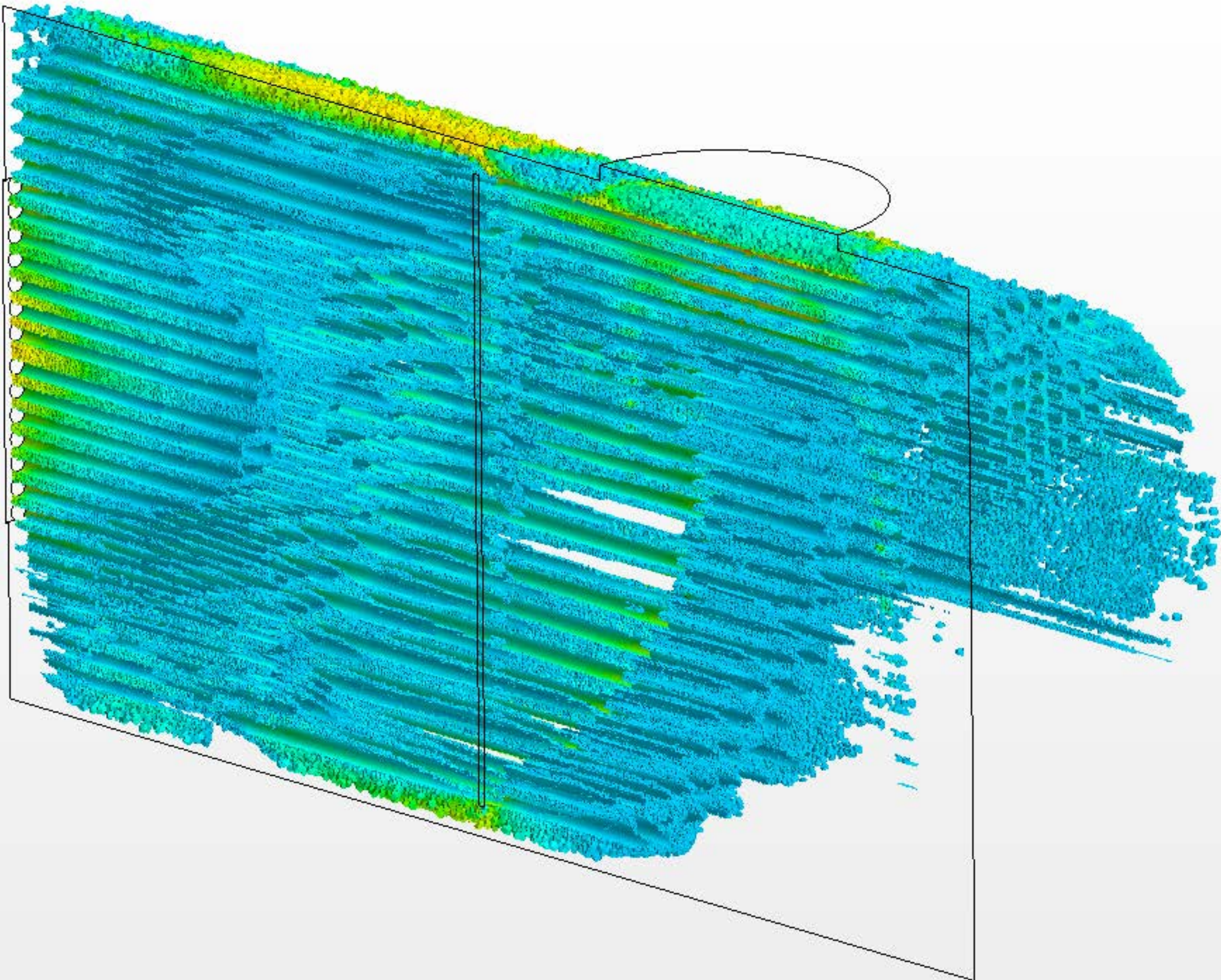
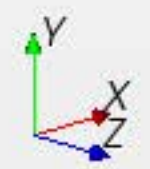

Velocity: Magnitude (m/s)

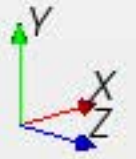
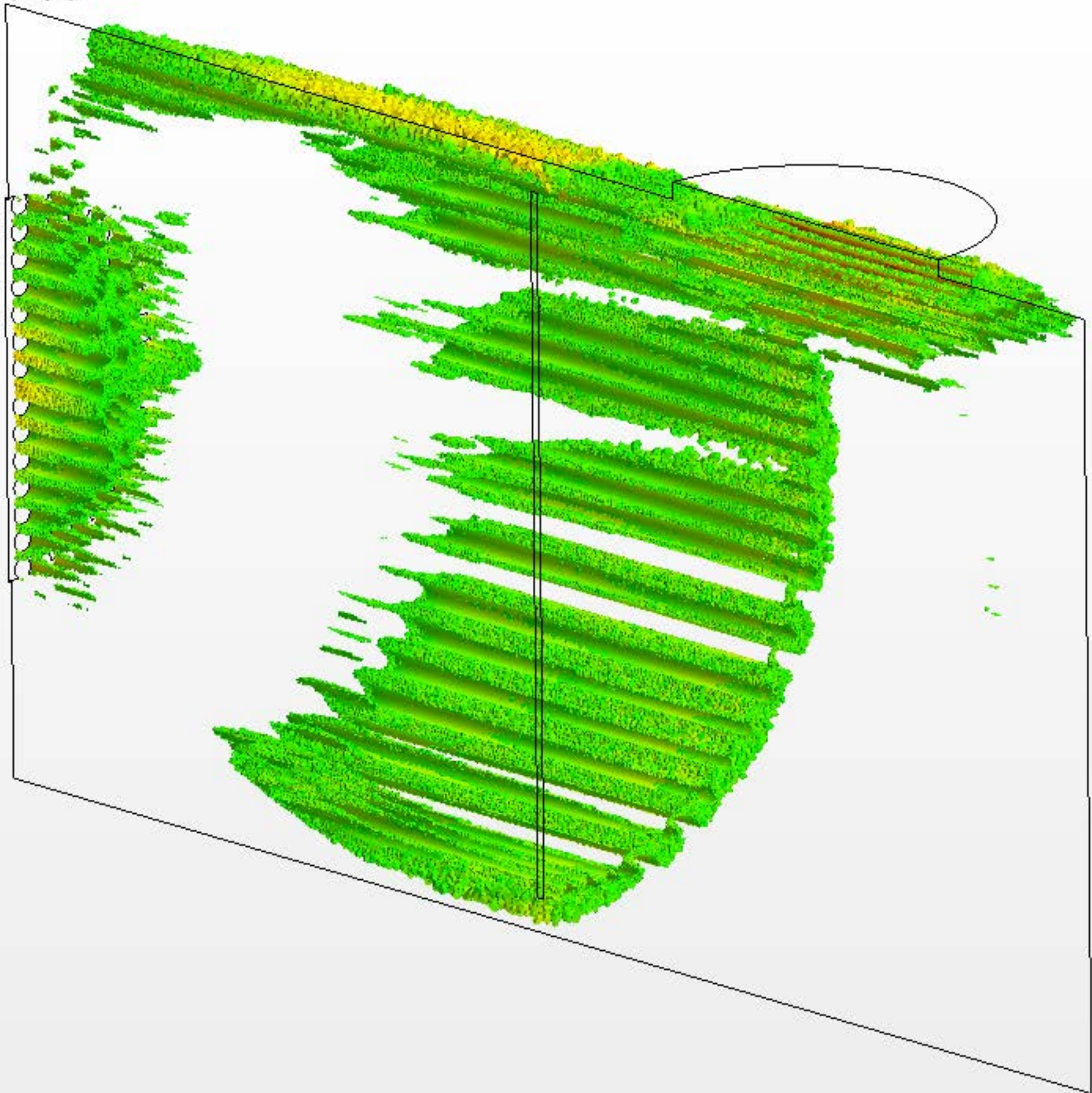

Velocity: Magnitude (m/s)

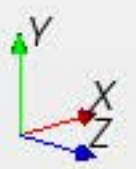
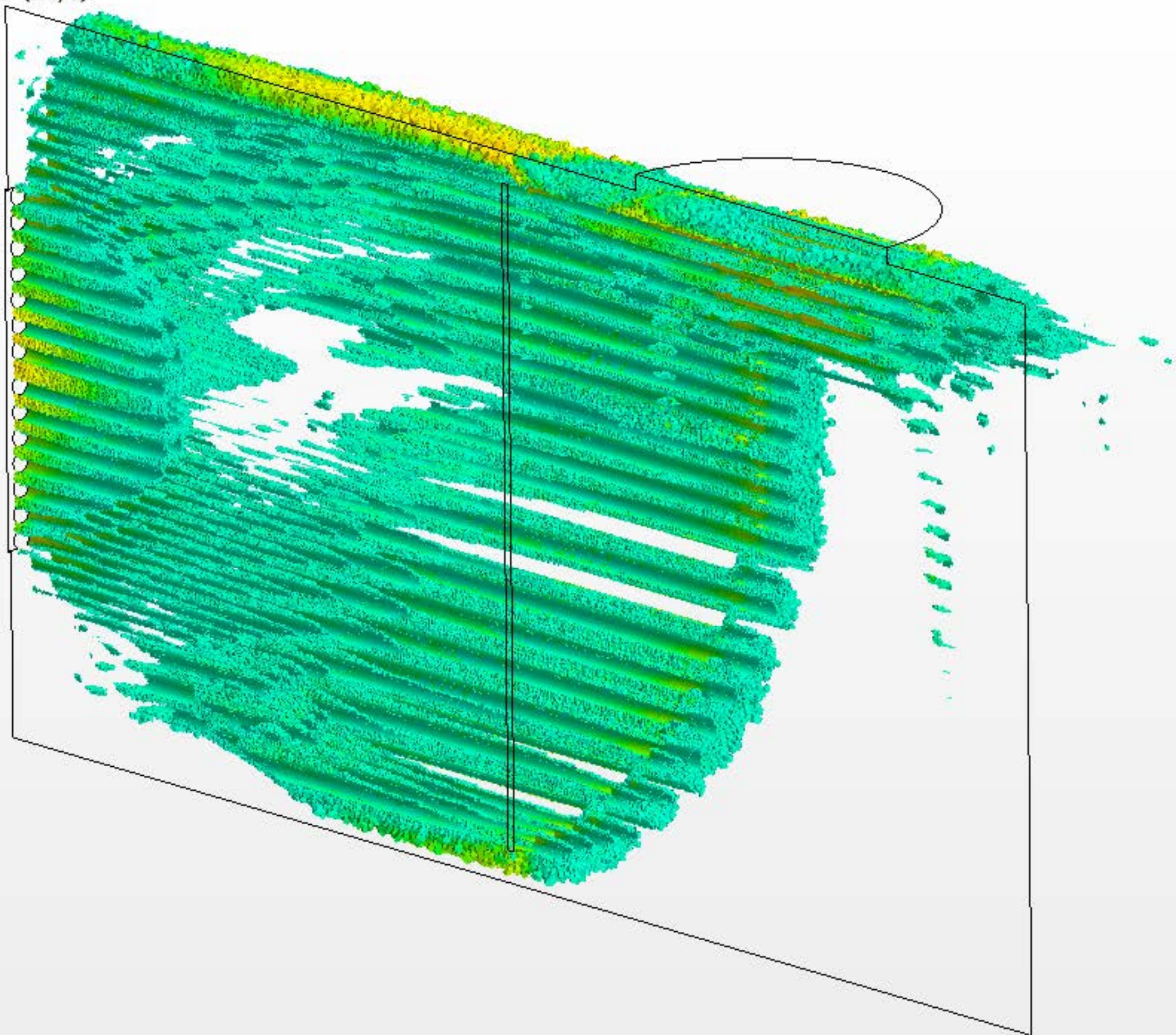

Velocity: Magnitude (m/s)

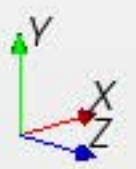
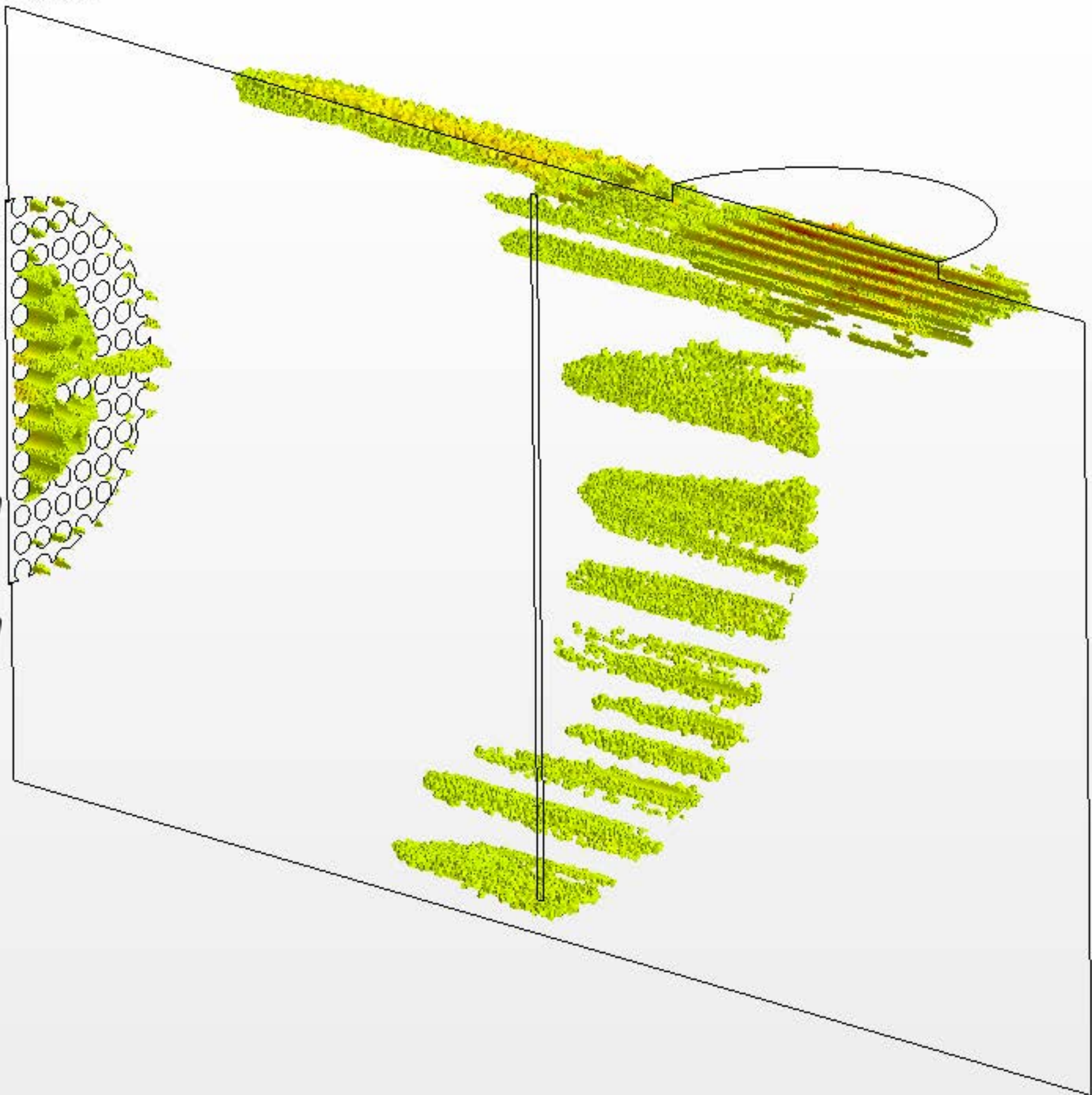
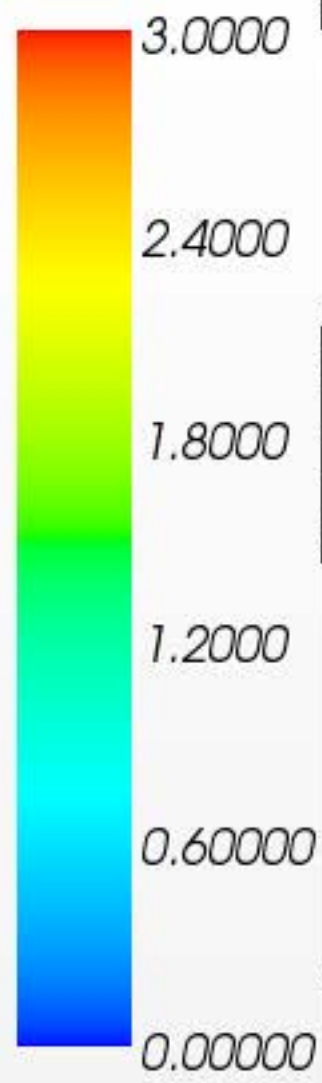

Velocity: Magnitude (m/s)

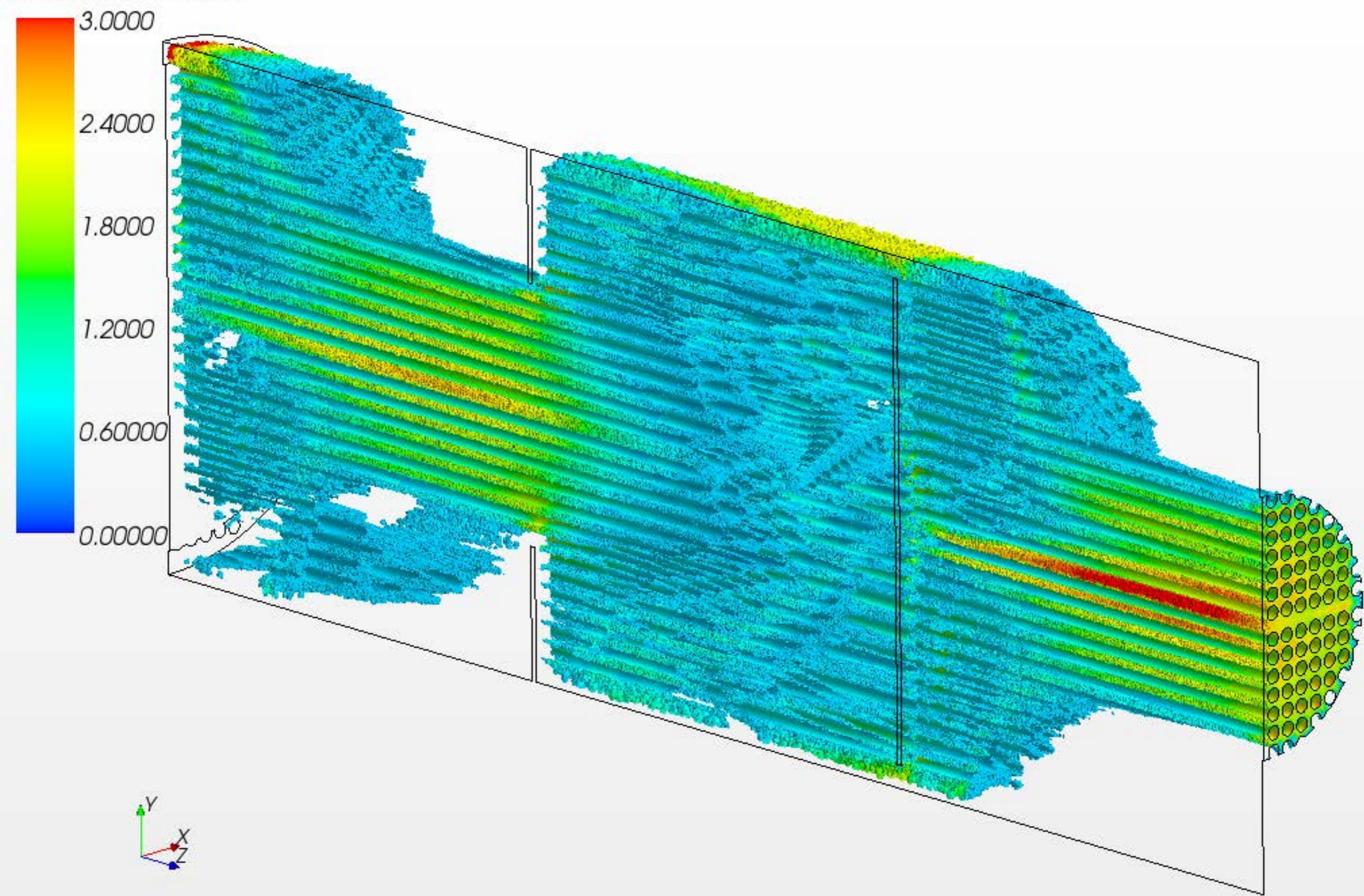

Velocity: Magnitude (m/s)

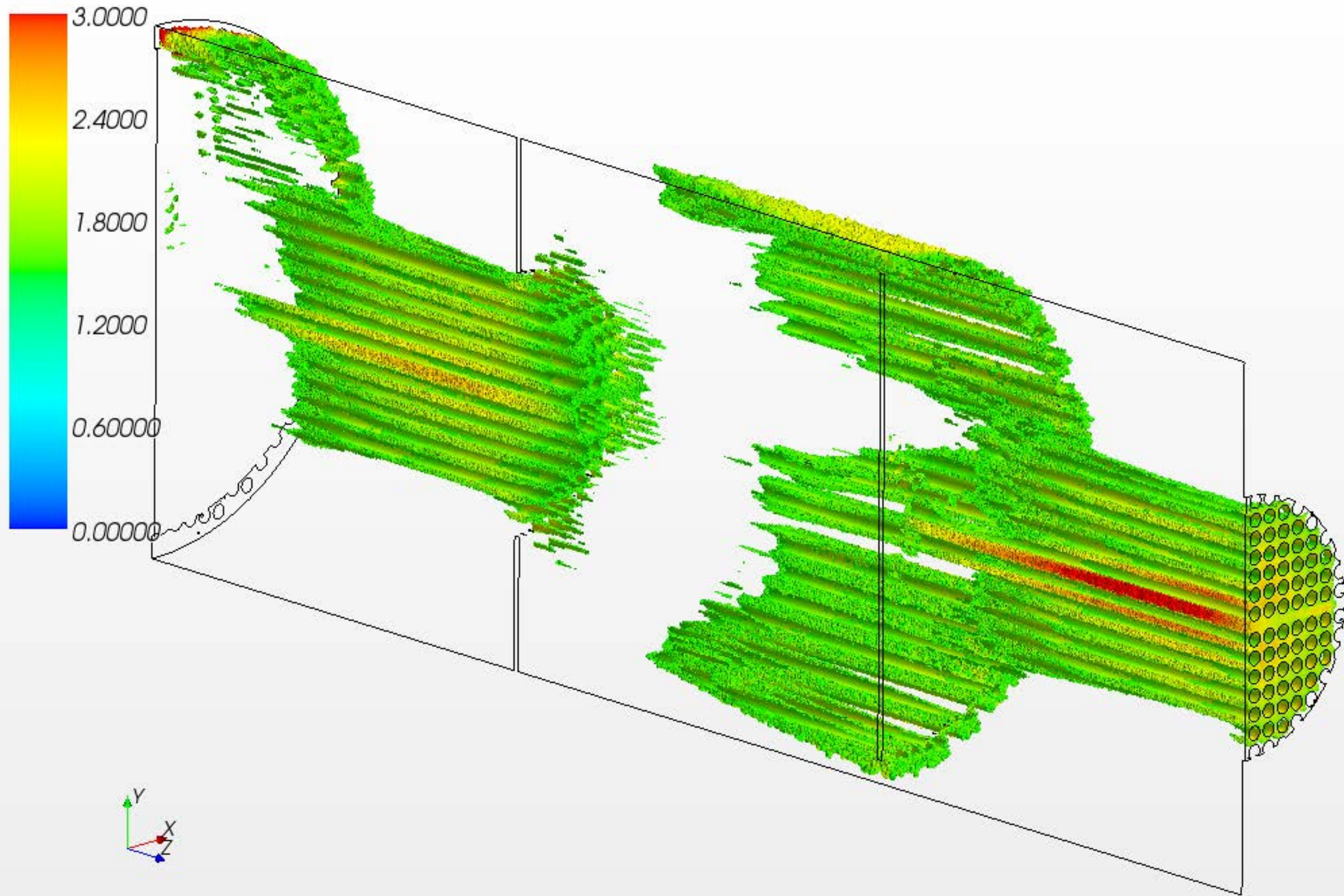

Velocity: Magnitude (m/s)

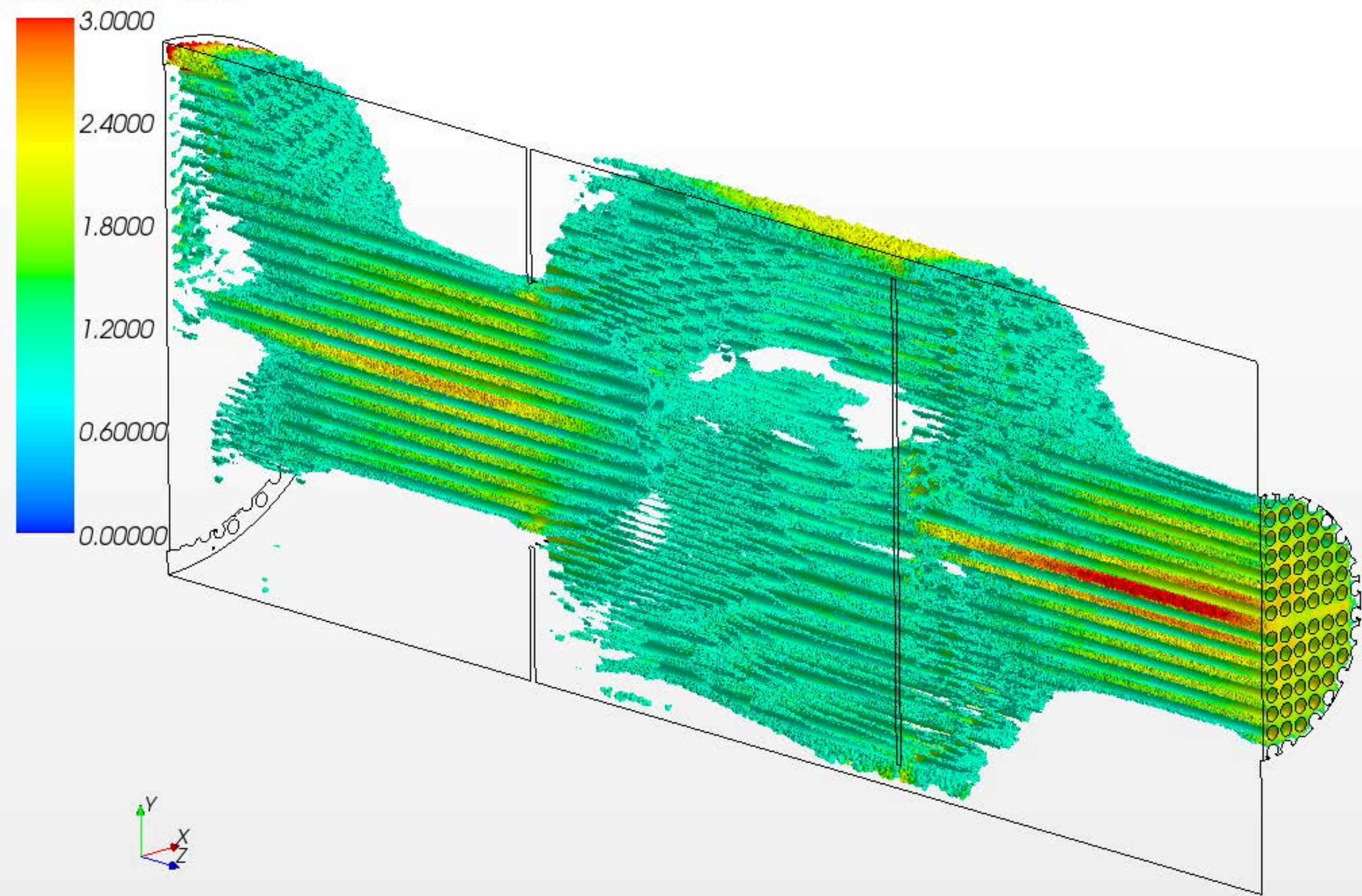

Velocity: Magnitude (m/s)

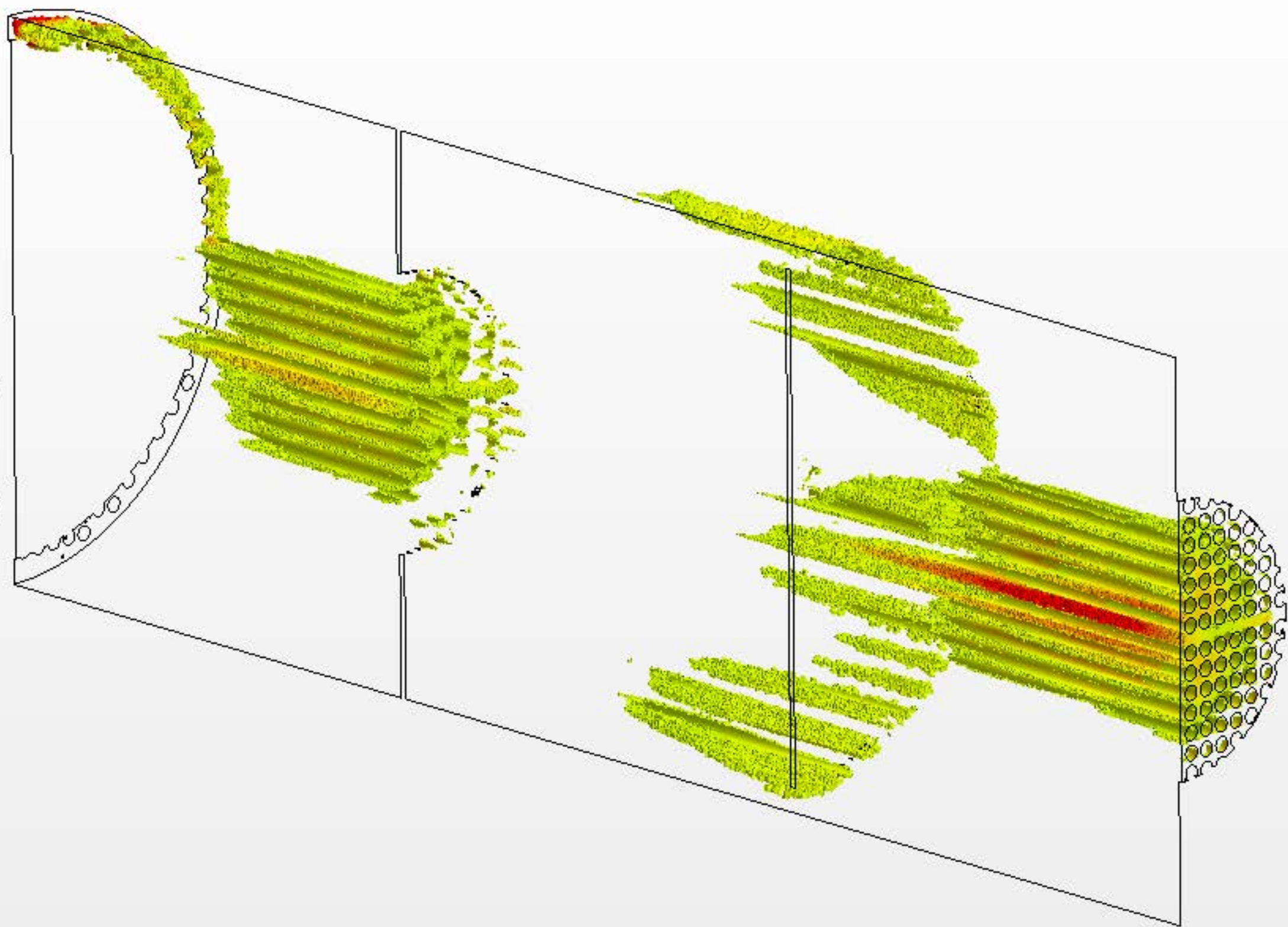
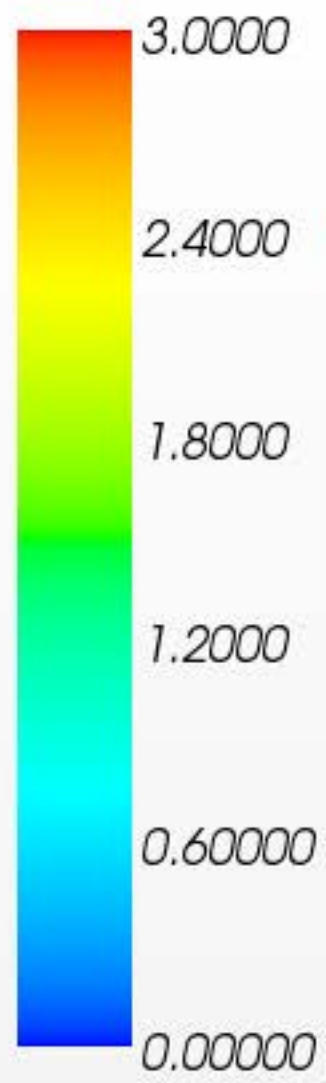

Velocity: Magnitude (m/s)

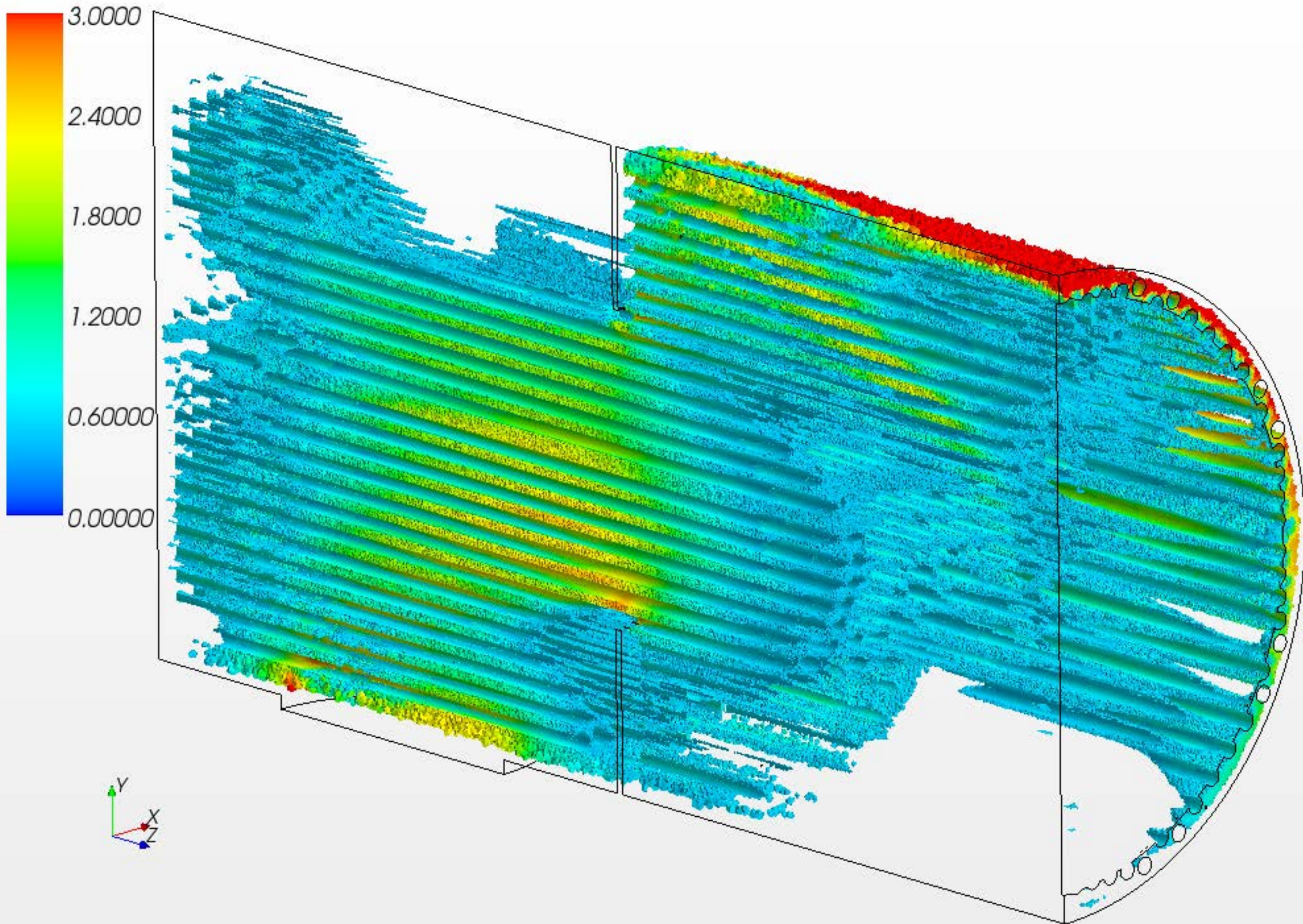

Velocity: Magnitude (m/s)

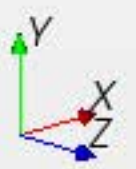
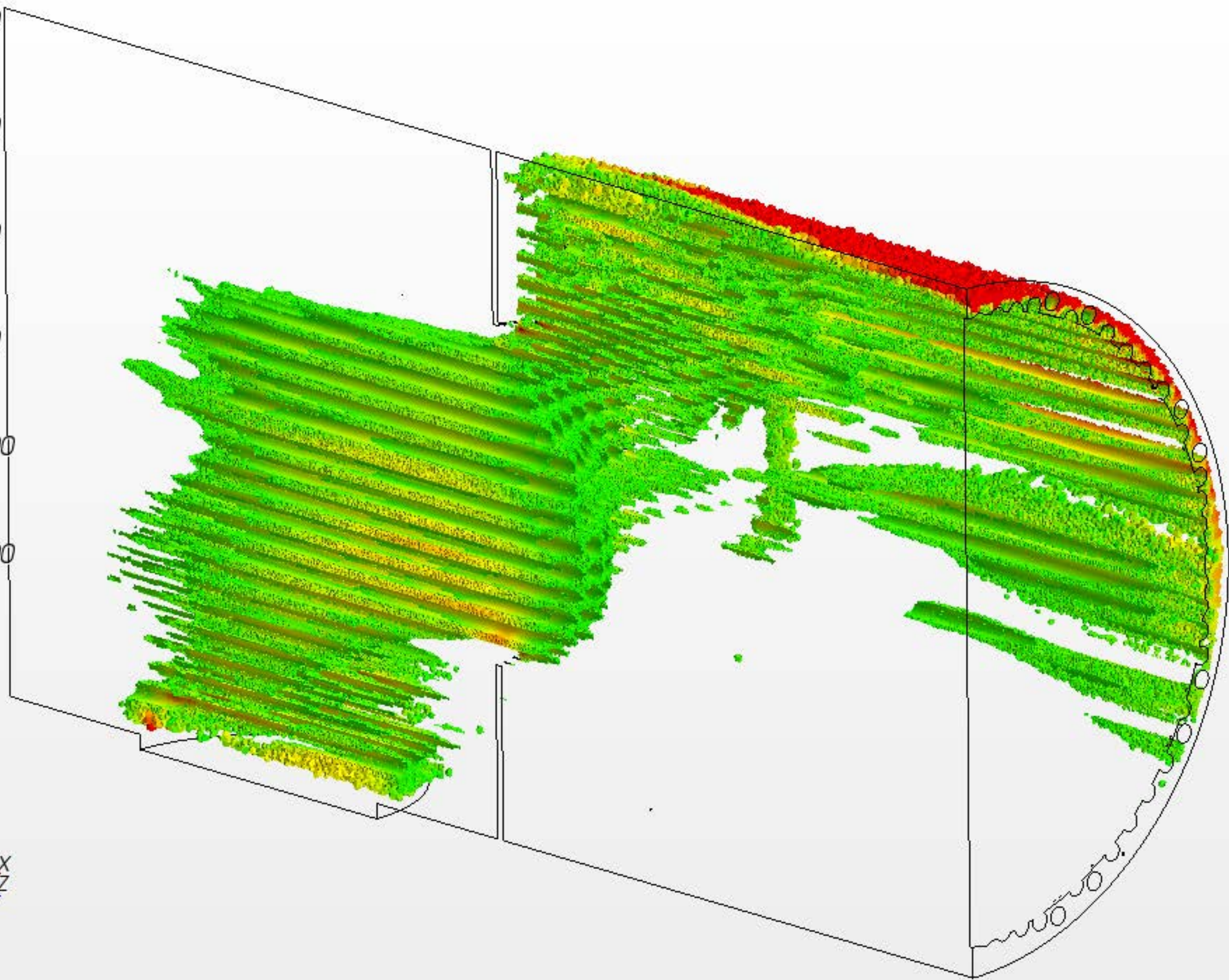
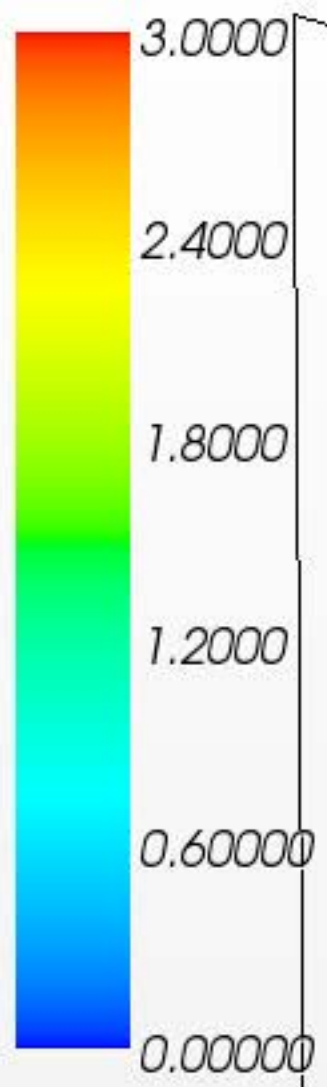

city: Magnitude (m/s)

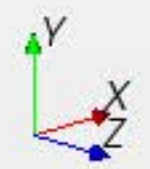
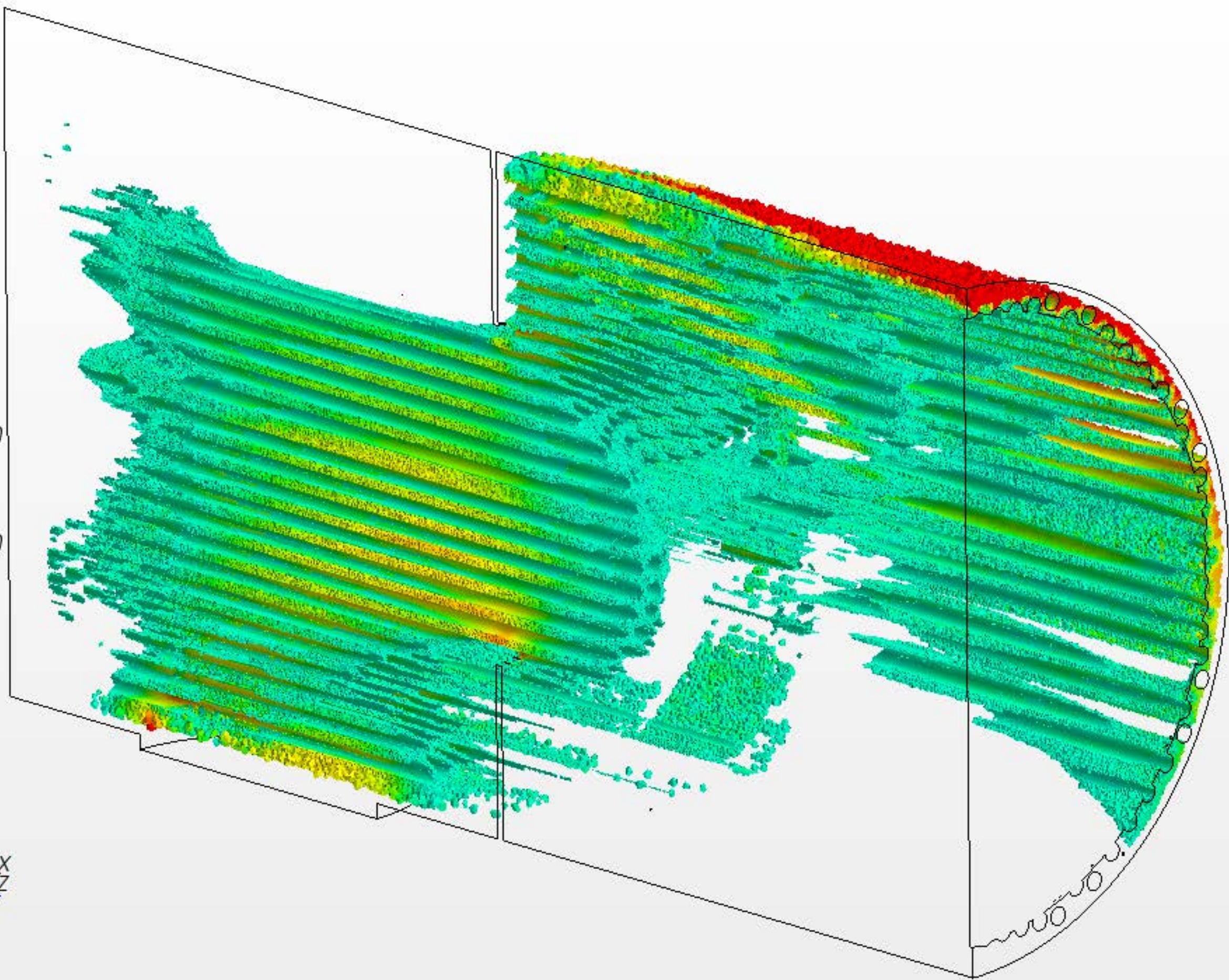
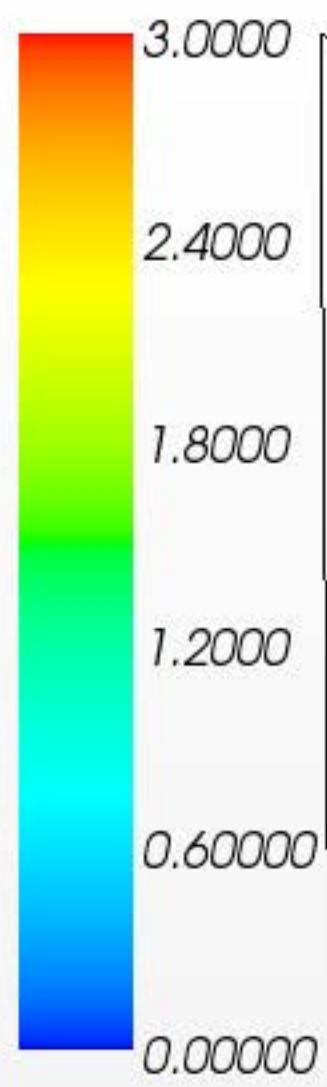

city: Magnitude (m/s)

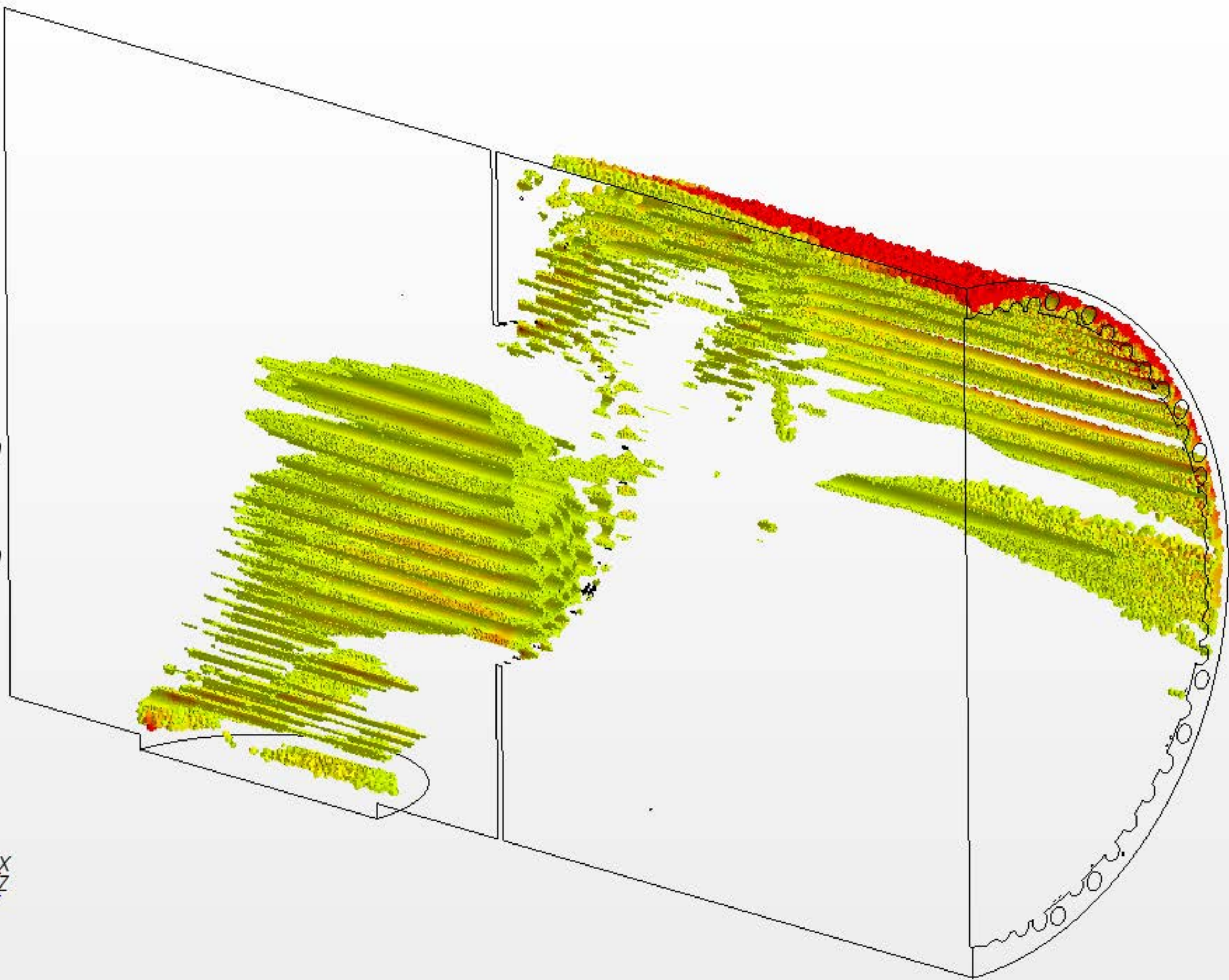
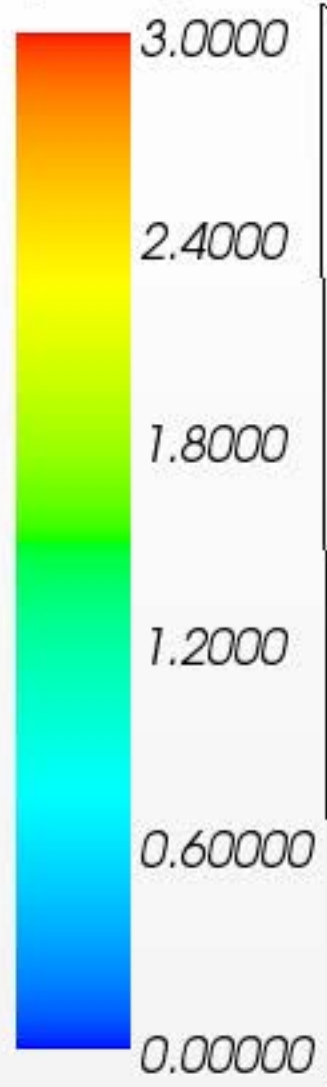

Velocity: Magnitude (m/s)

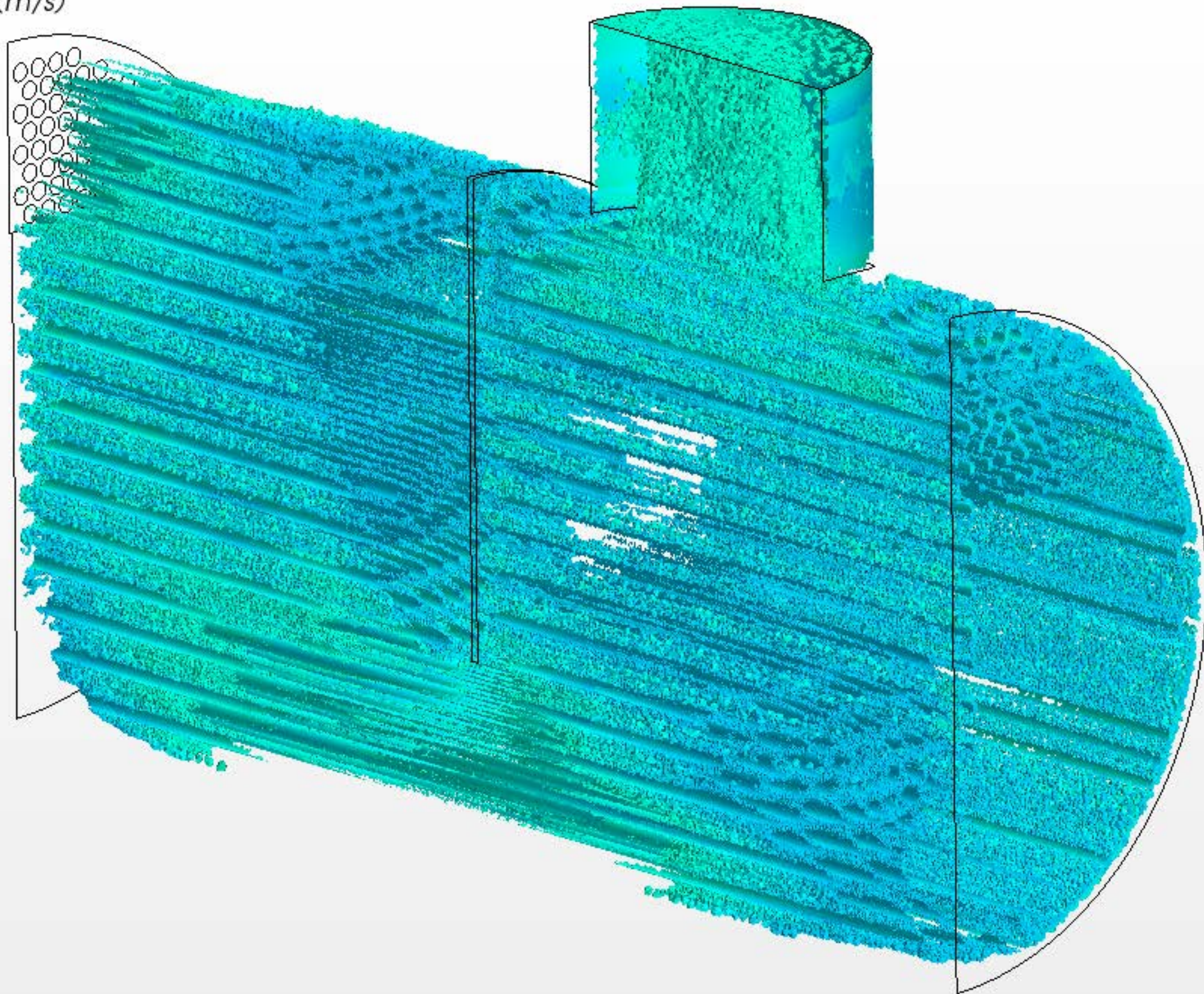

Velocity: Magnitude (m/s)

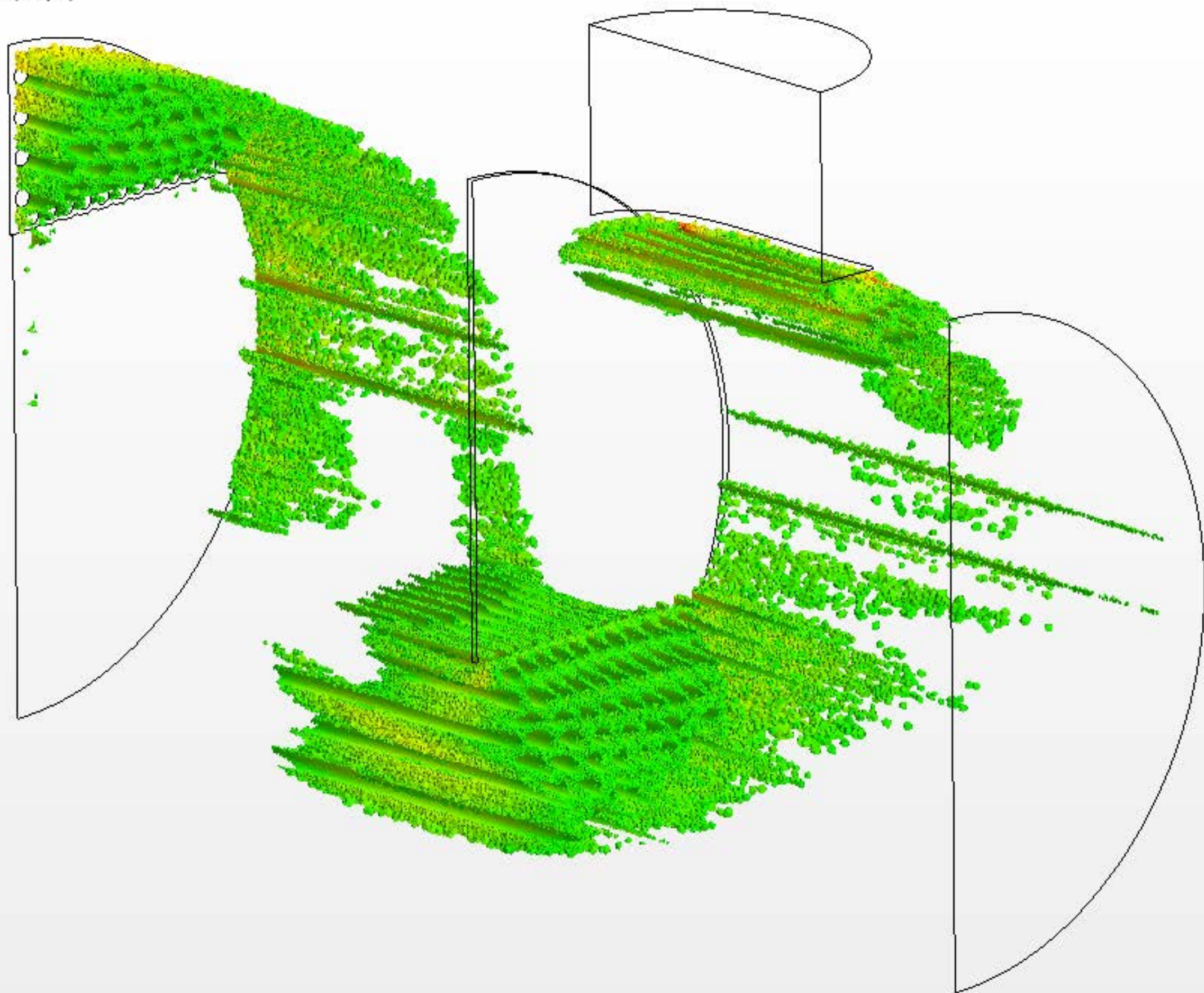
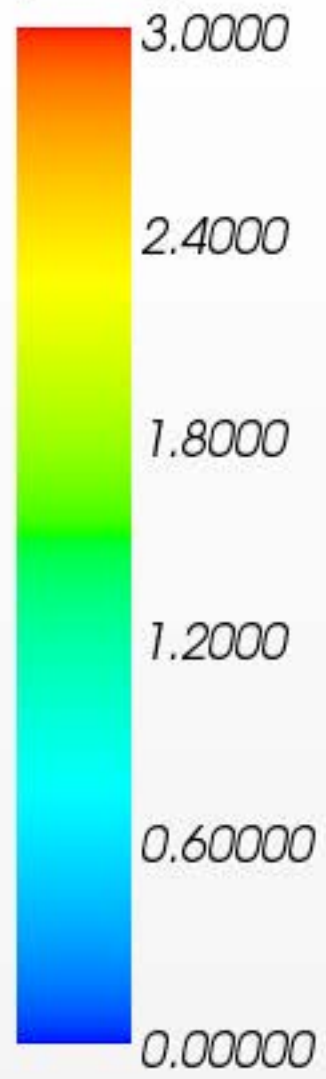

Velocity: Magnitude (m/s)

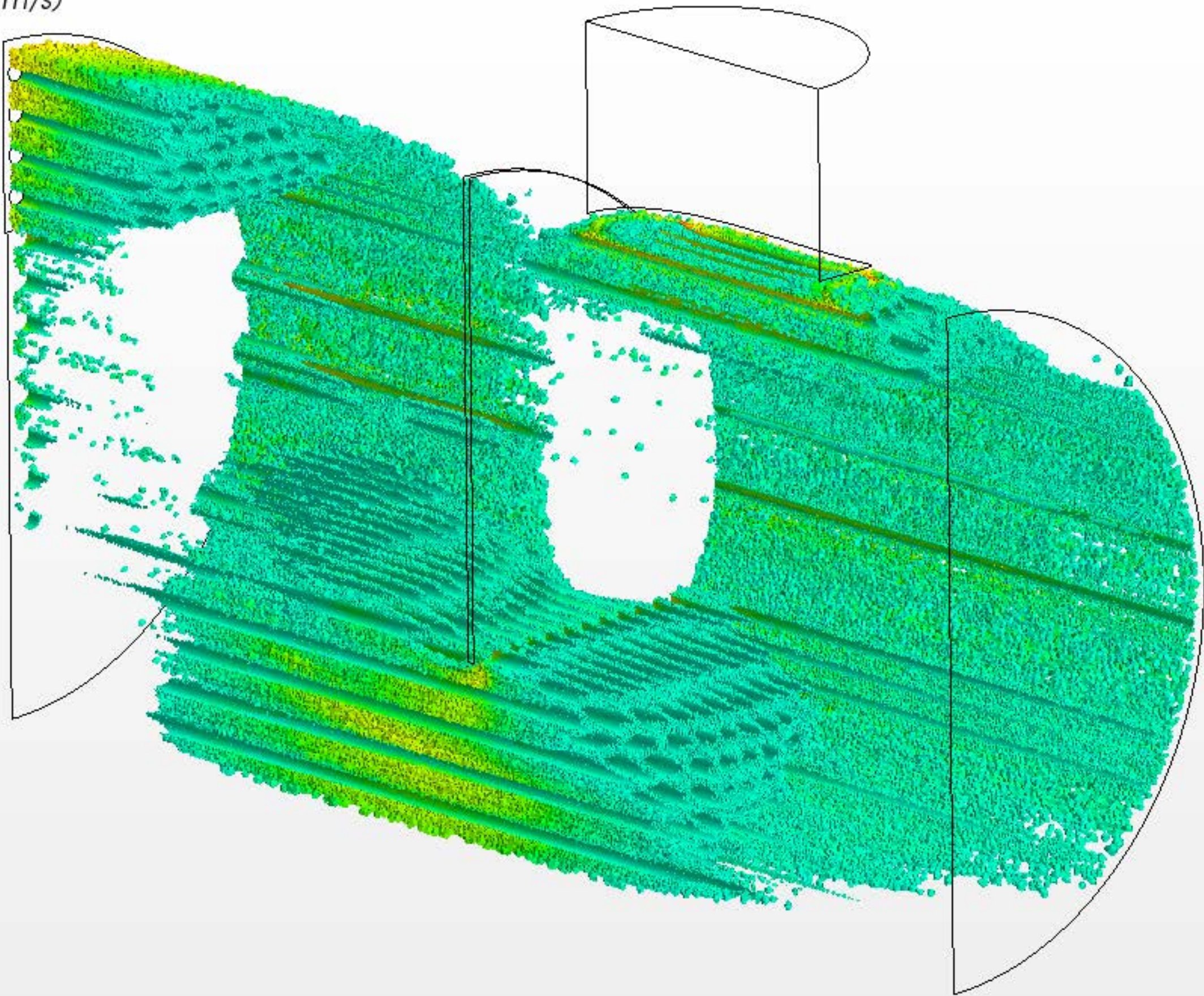
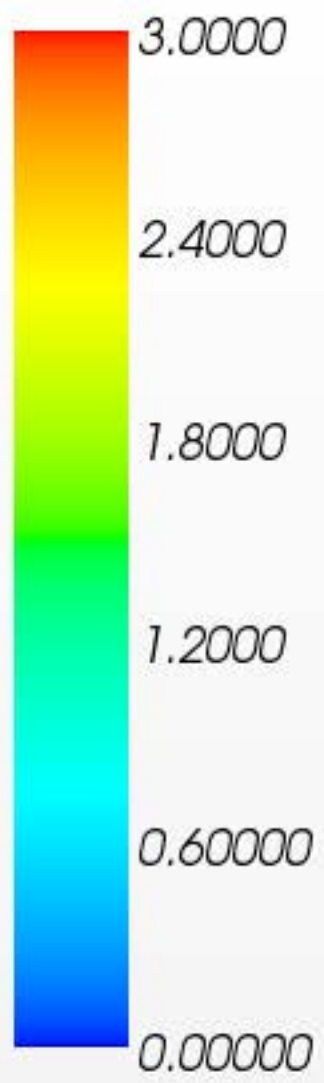

Velocity: Magnitude (m/s)

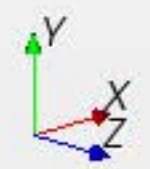
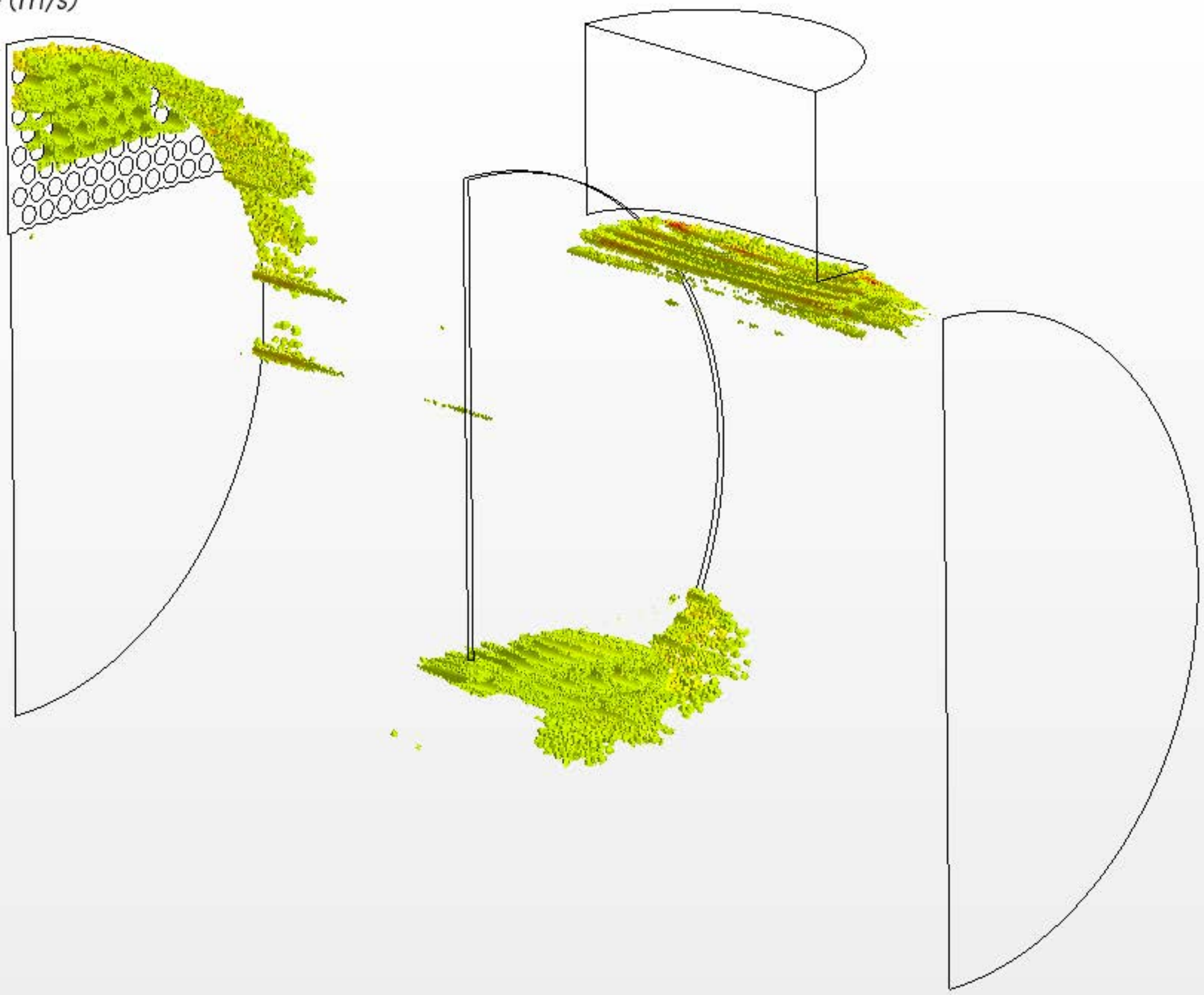

Velocity: Magnitude (m/s)

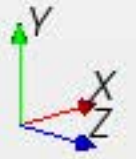
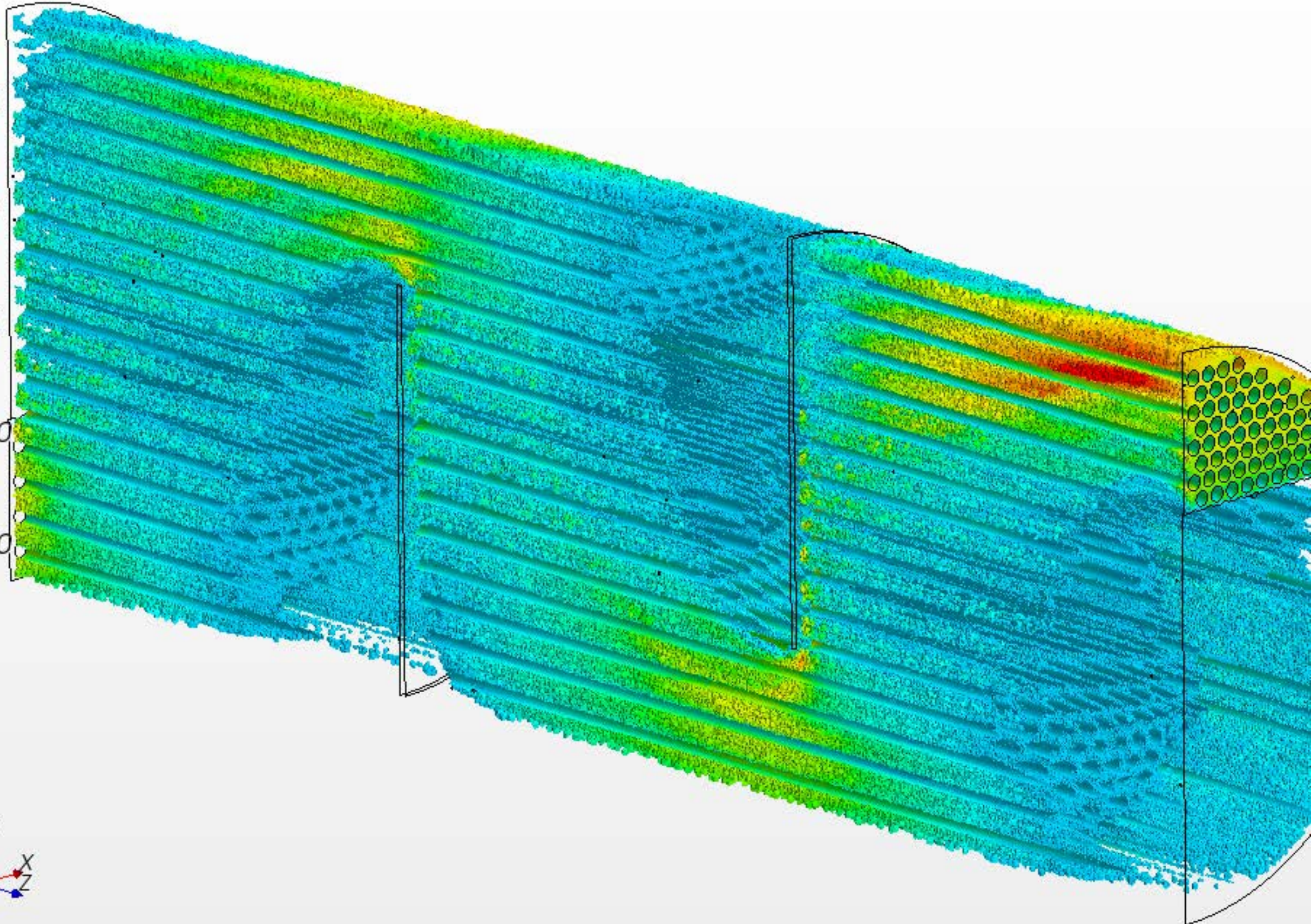
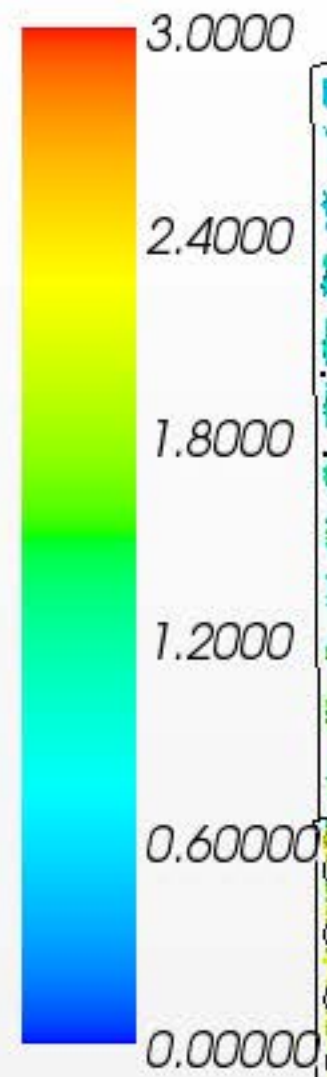

Velocity: Magnitude (m/s)

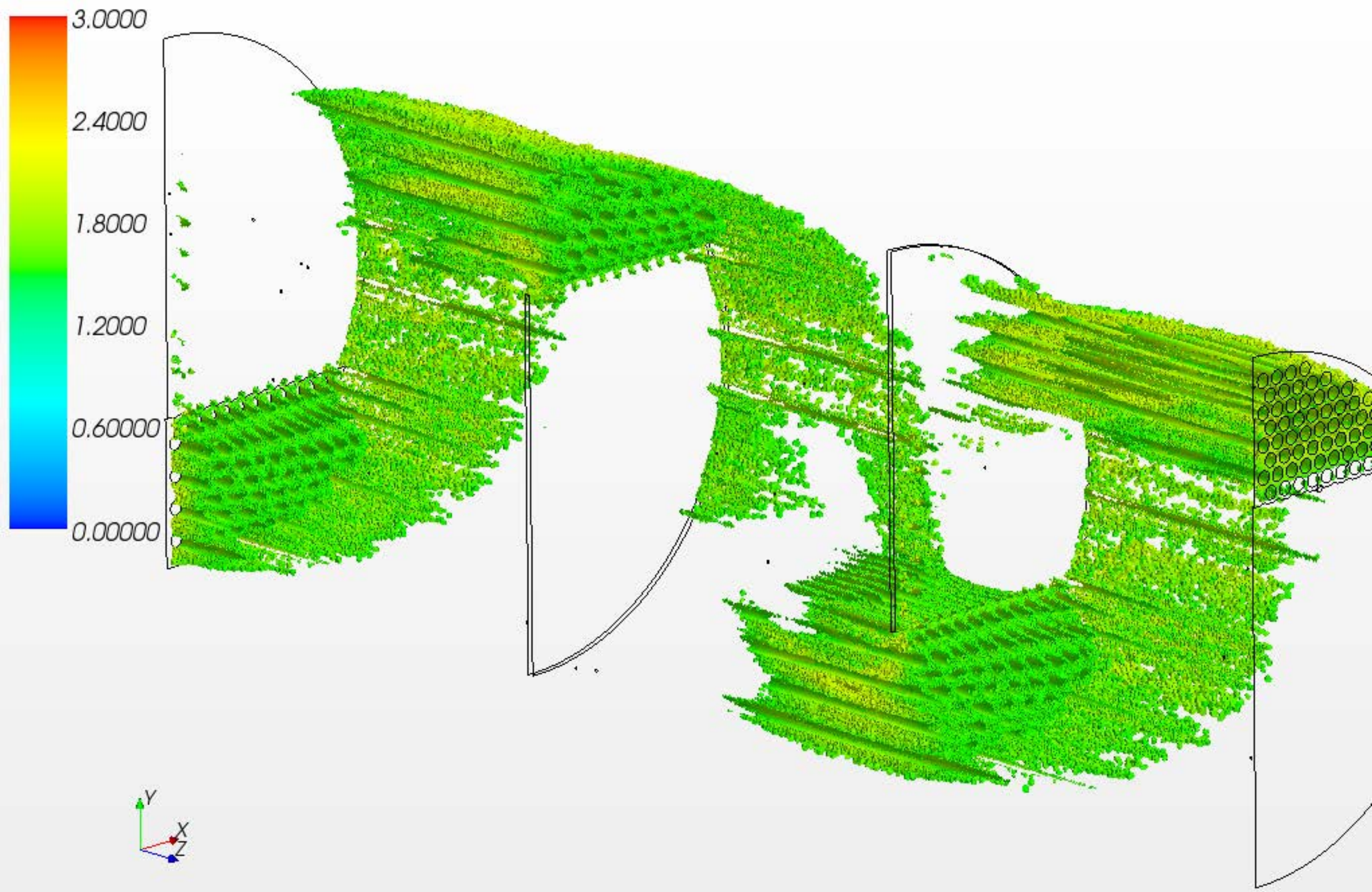

Velocity: Magnitude (m/s)

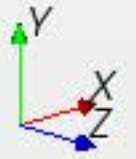
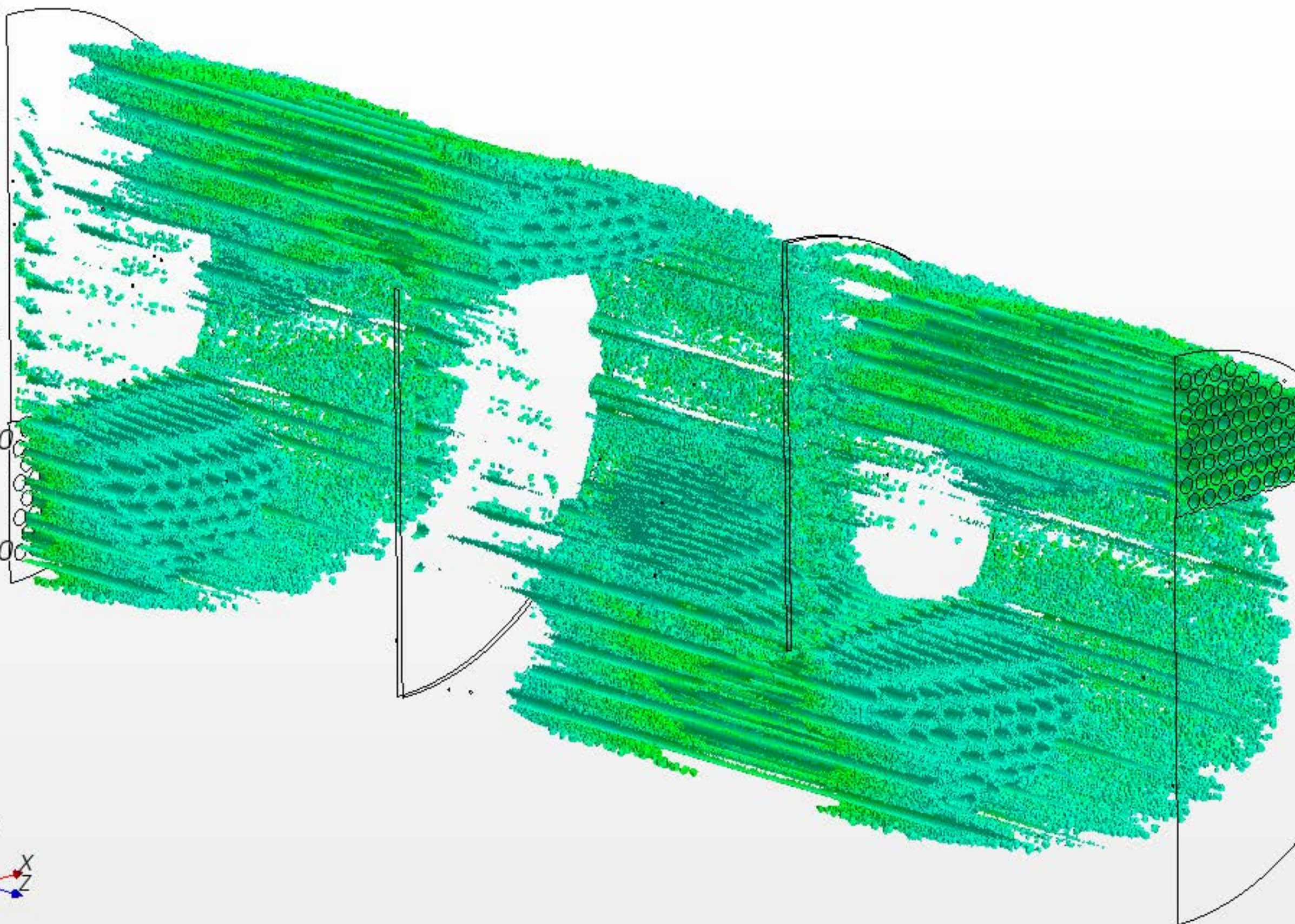

Velocity: Magnitude (m/s)

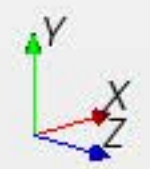
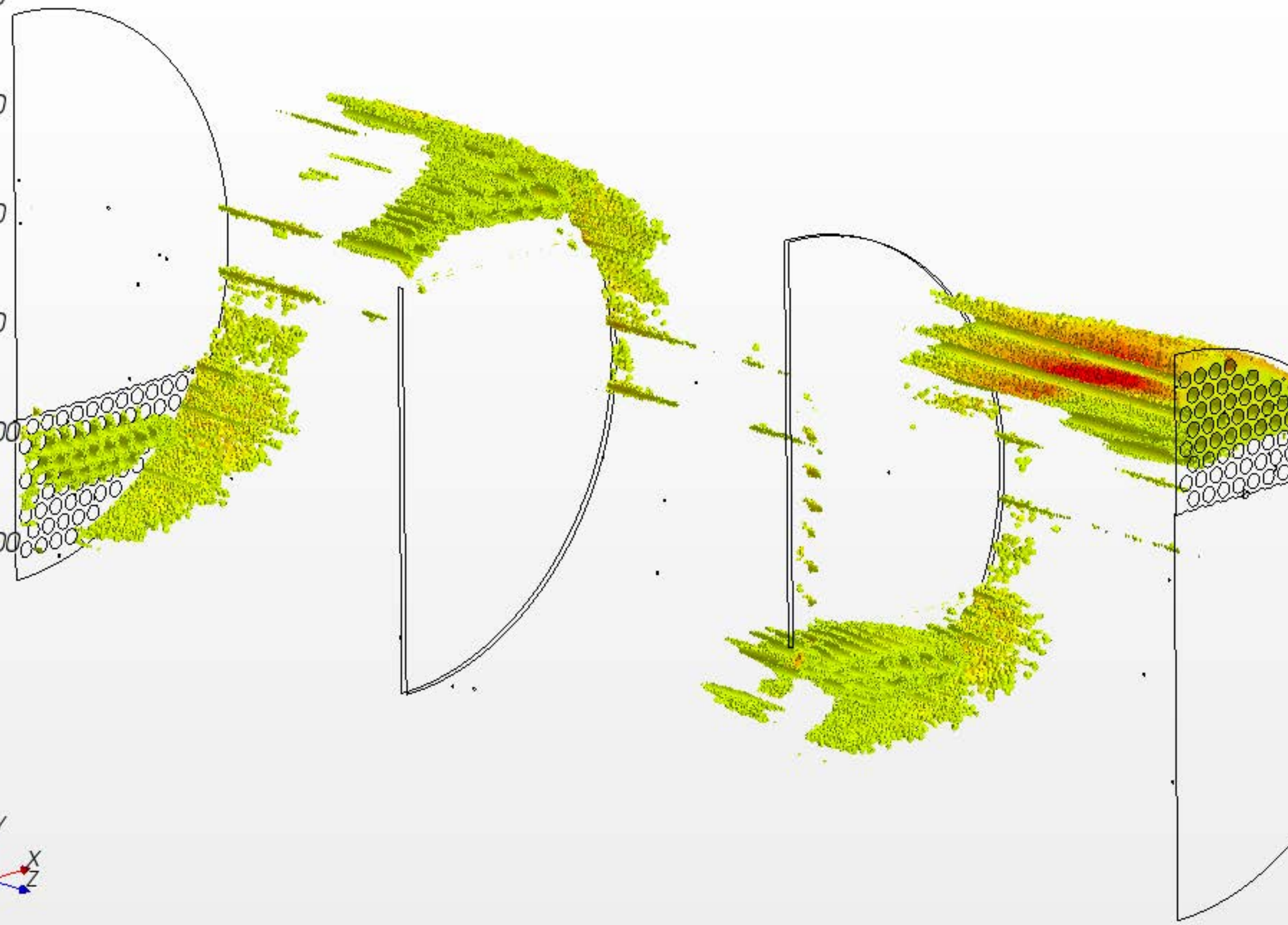
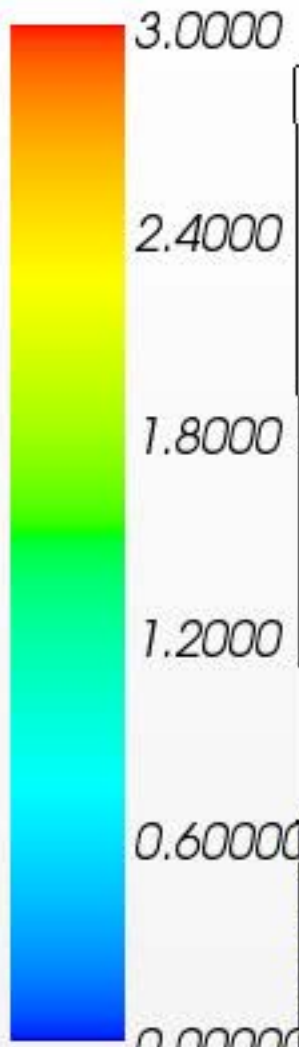

Velocity: Magnitude (m/s)

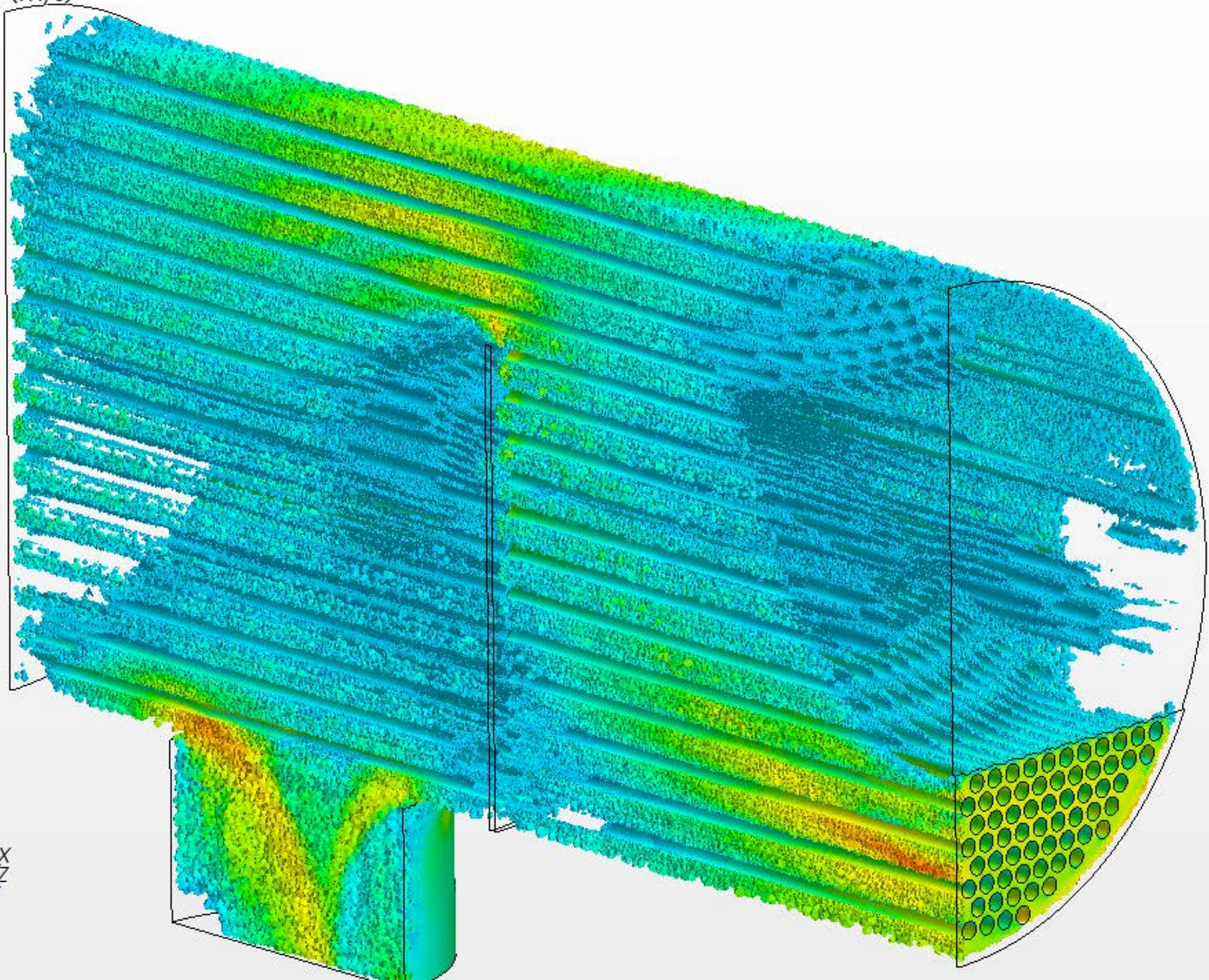
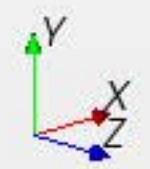

Velocity: Magnitude (m/s)

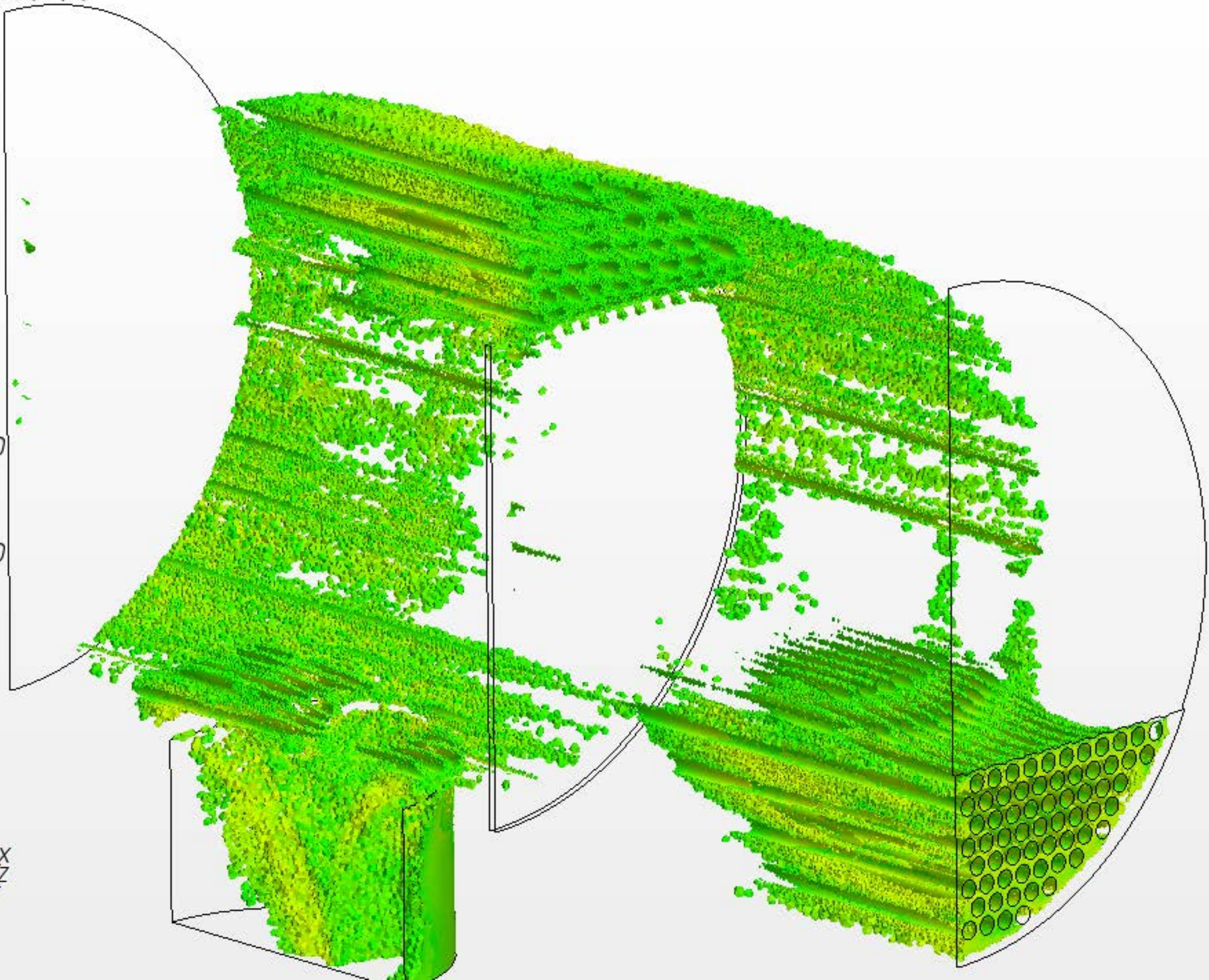
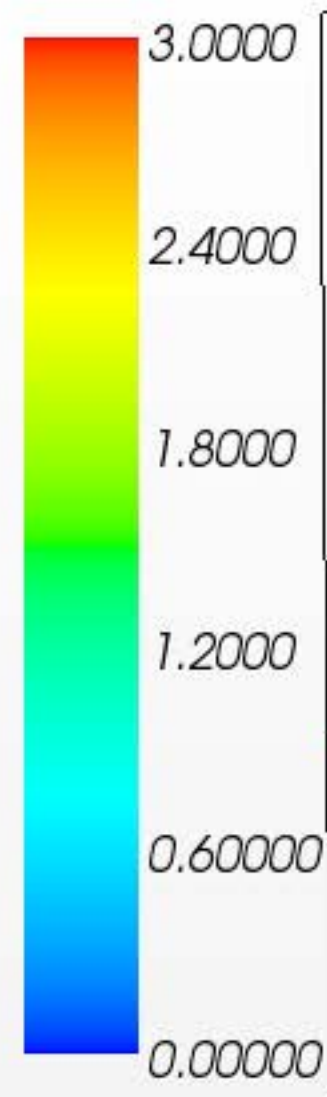

Velocity: Magnitude (m/s)

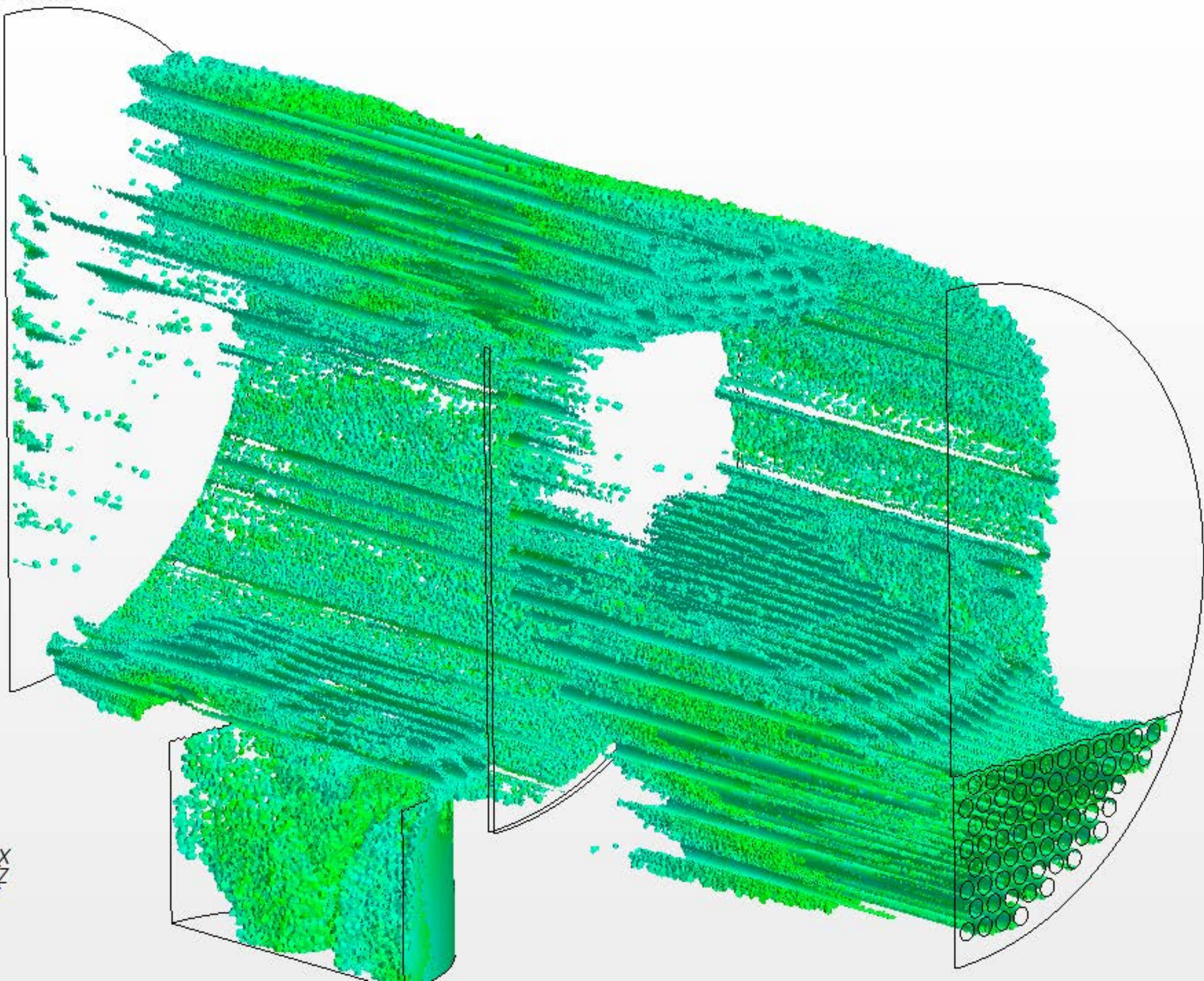
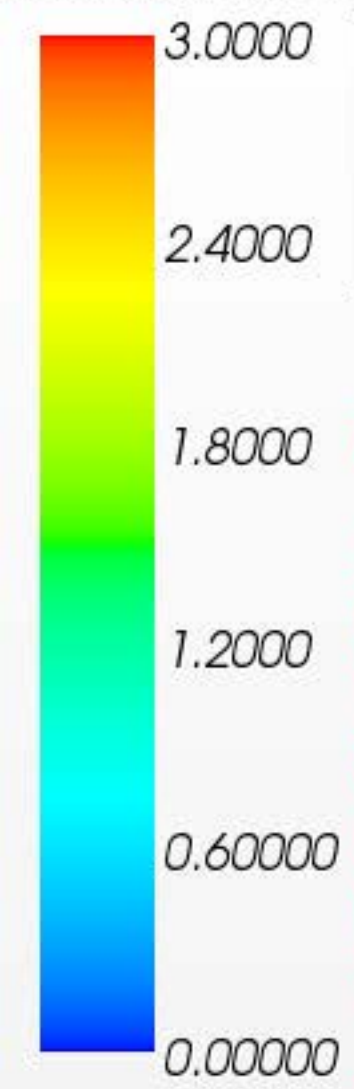

Velocity: Magnitude (m/s)

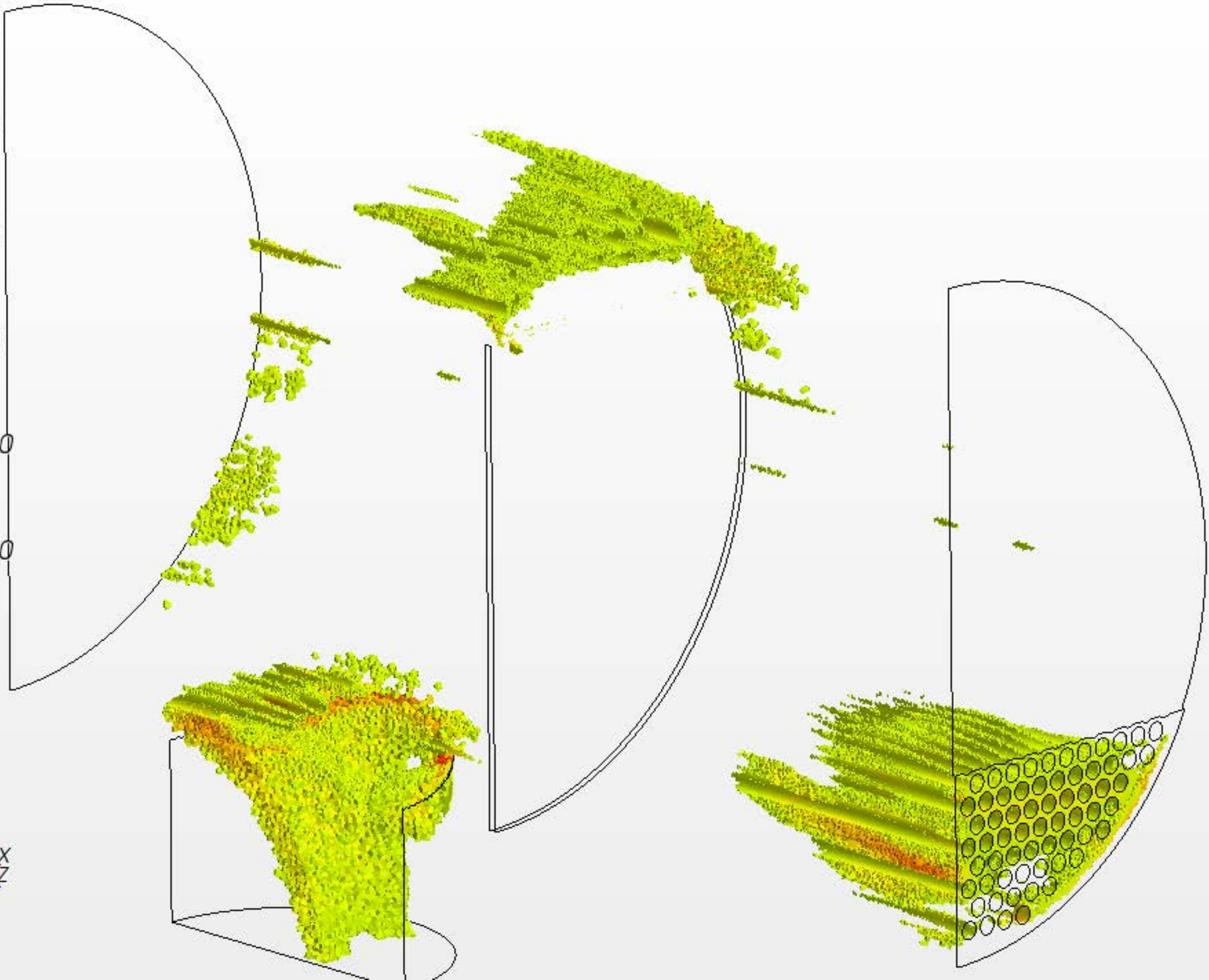
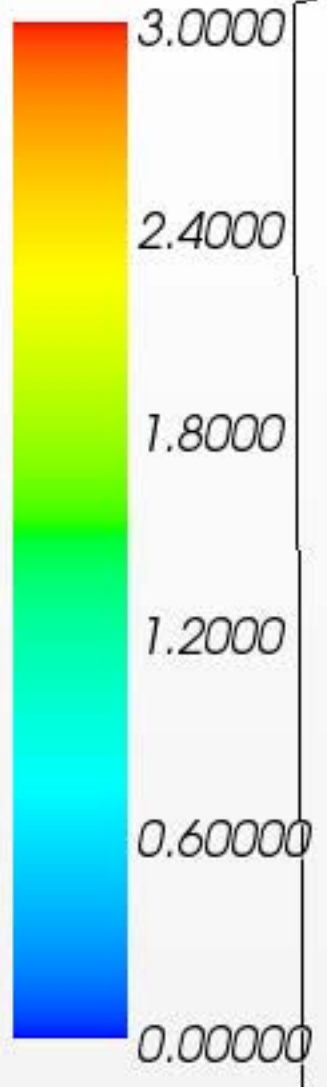

Velocity: Magnitude (m/s)

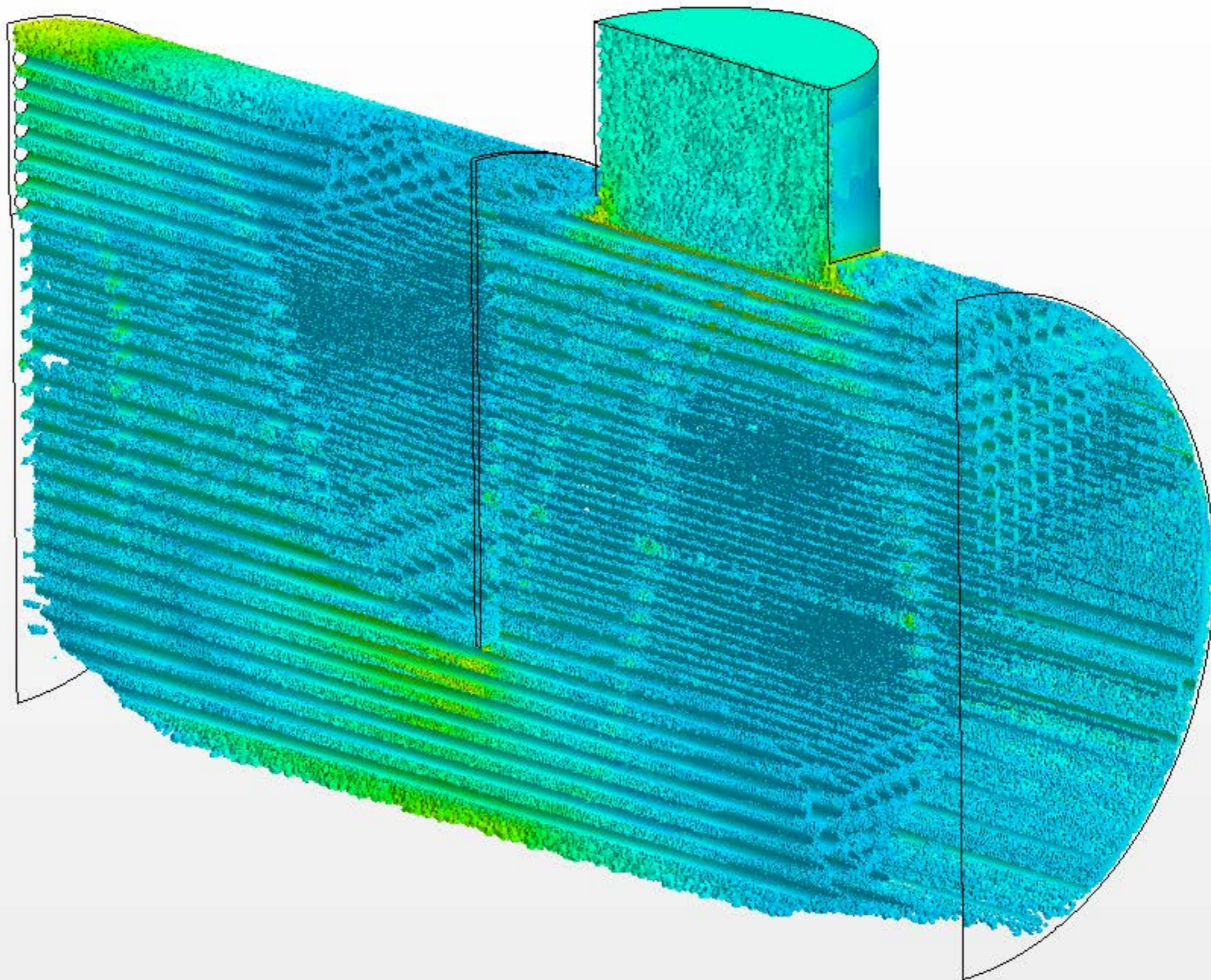

Velocity: Magnitude (m/s)

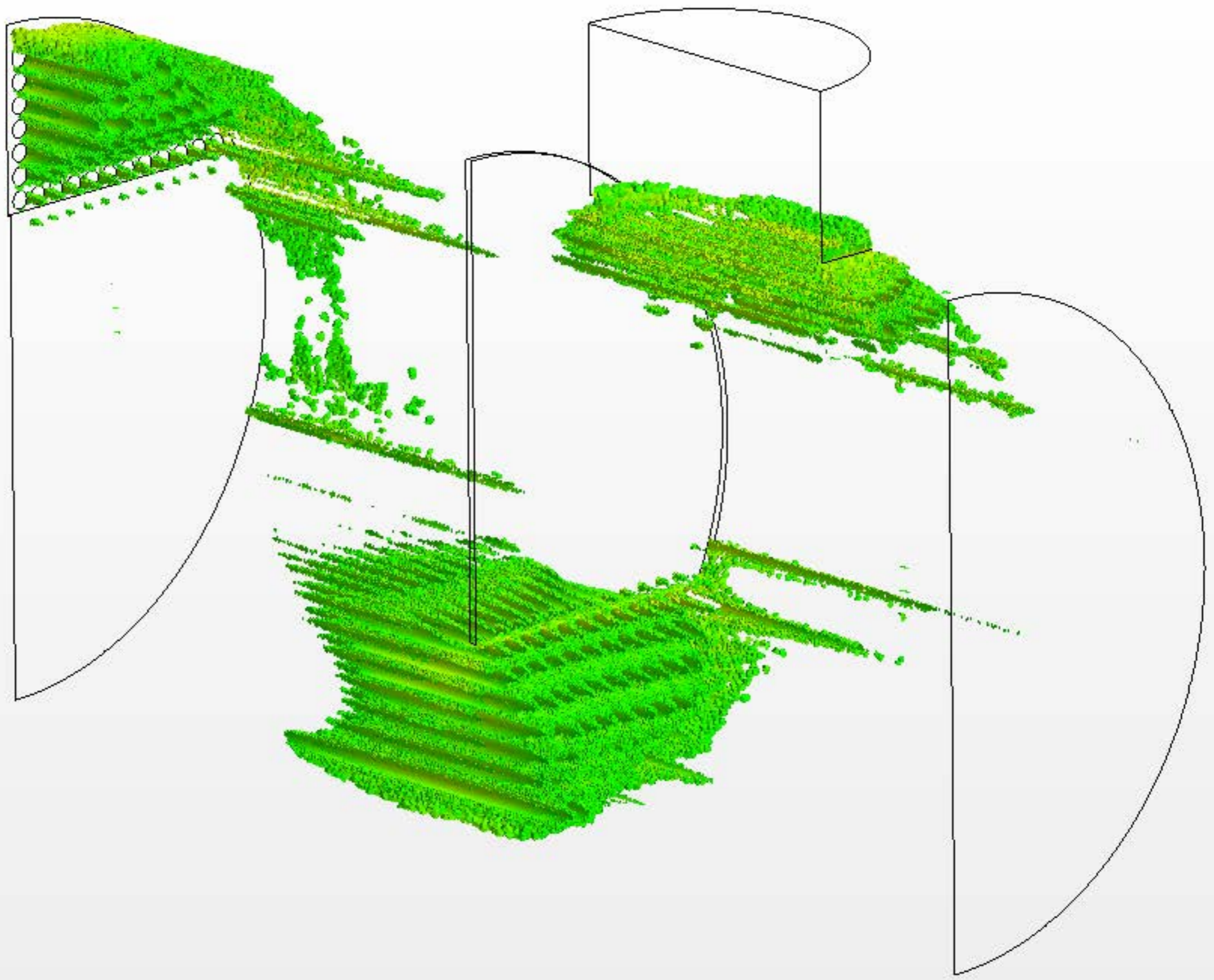

Velocity: Magnitude (m/s)

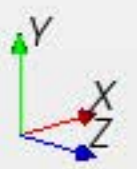
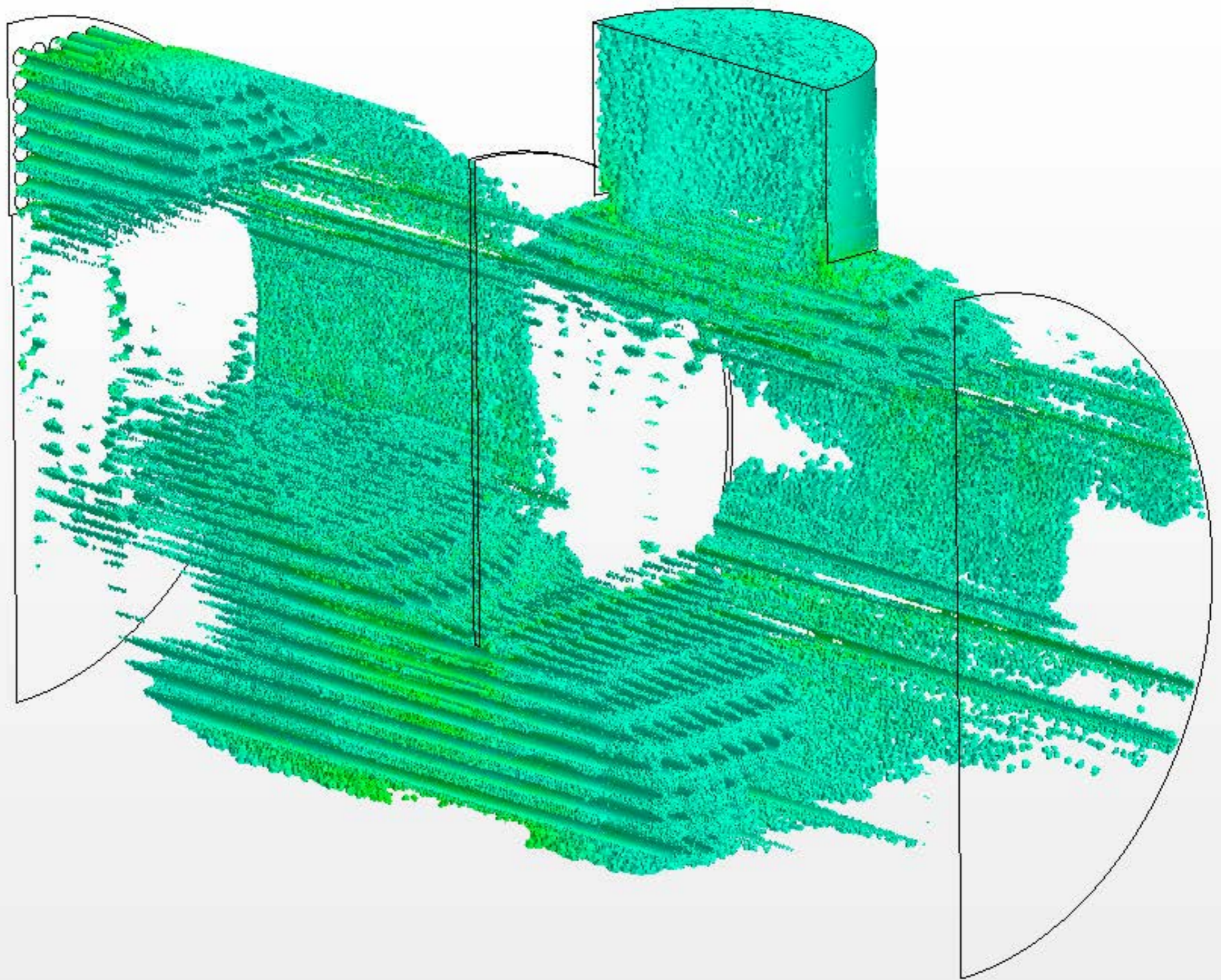
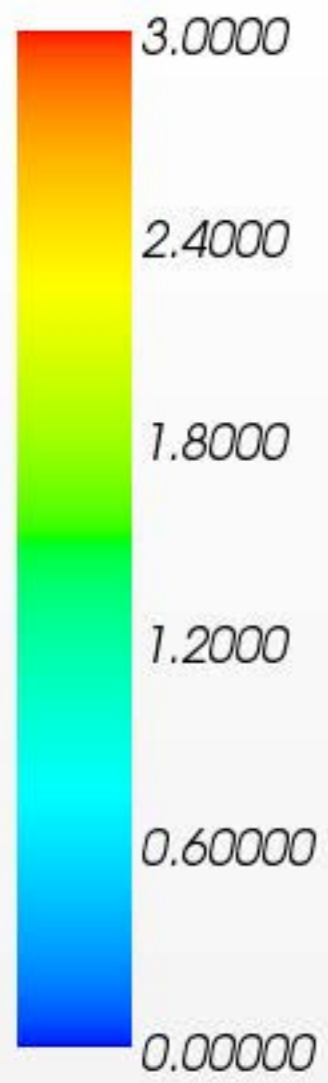

Velocity: Magnitude (m/s)

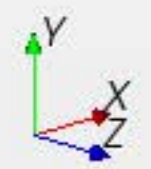
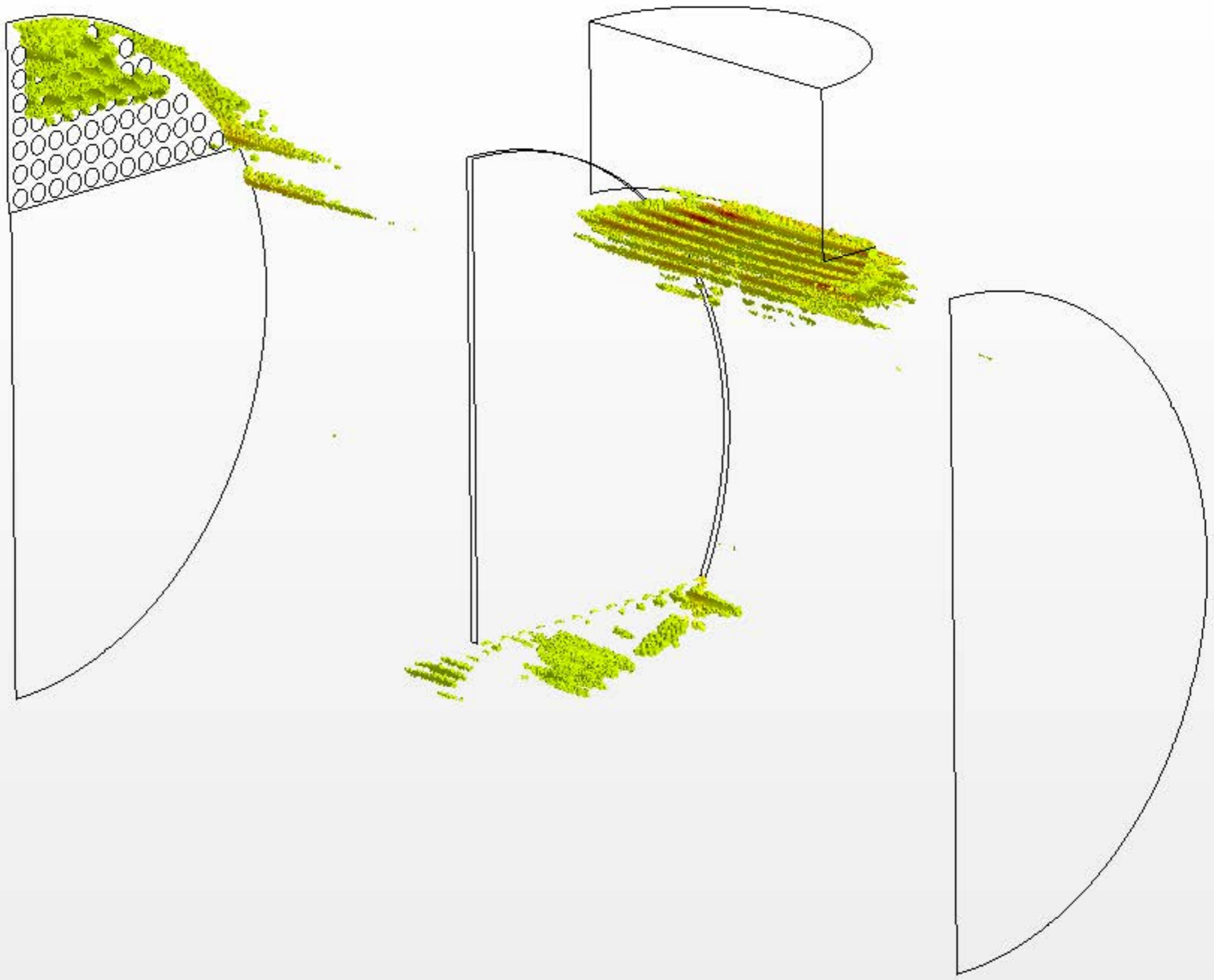

Velocity: Magnitude (m/s)

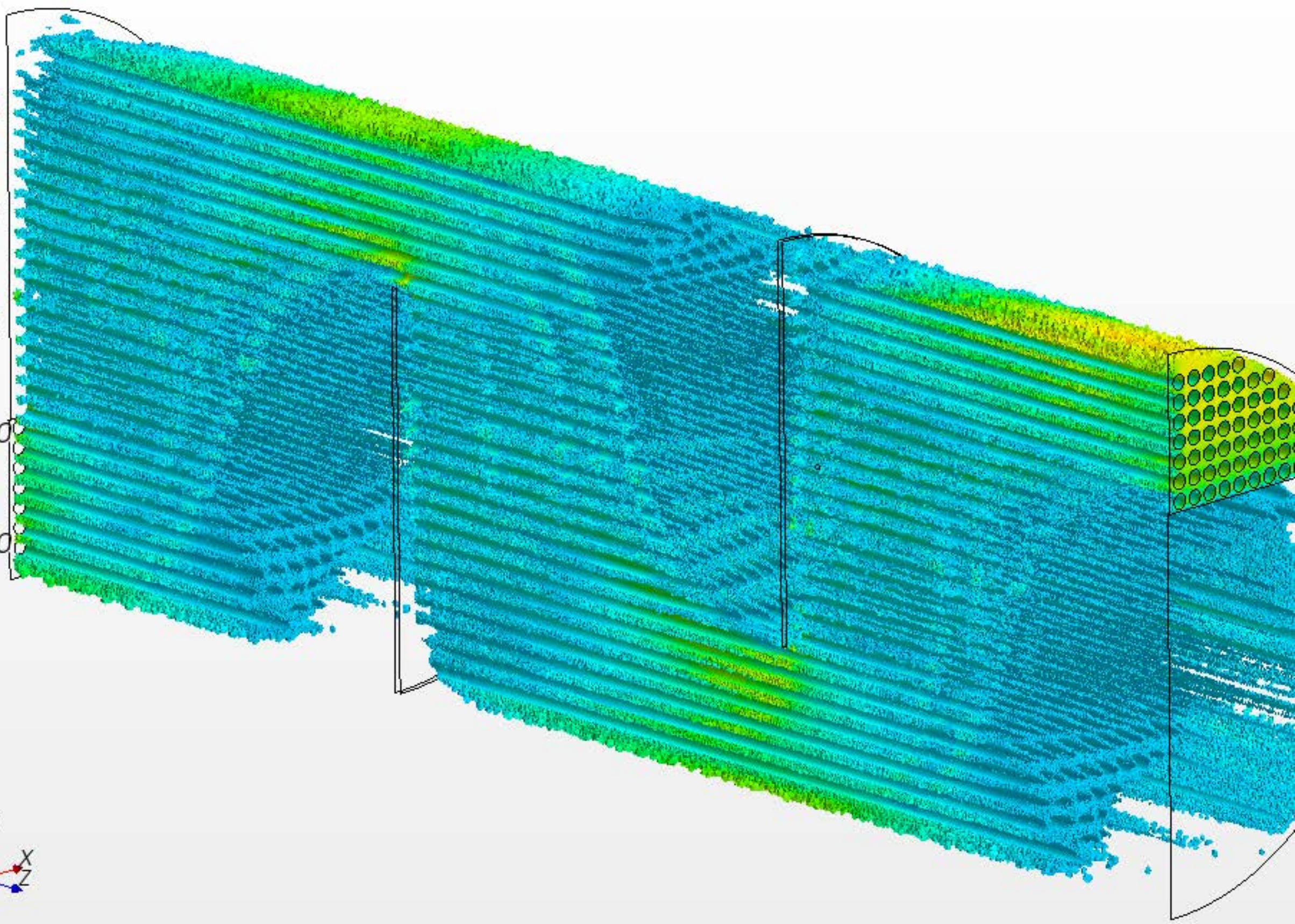
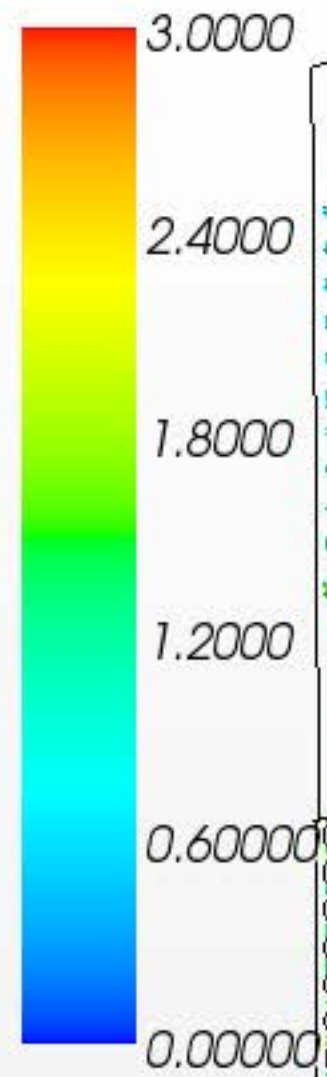

Velocity: Magnitude (m/s)

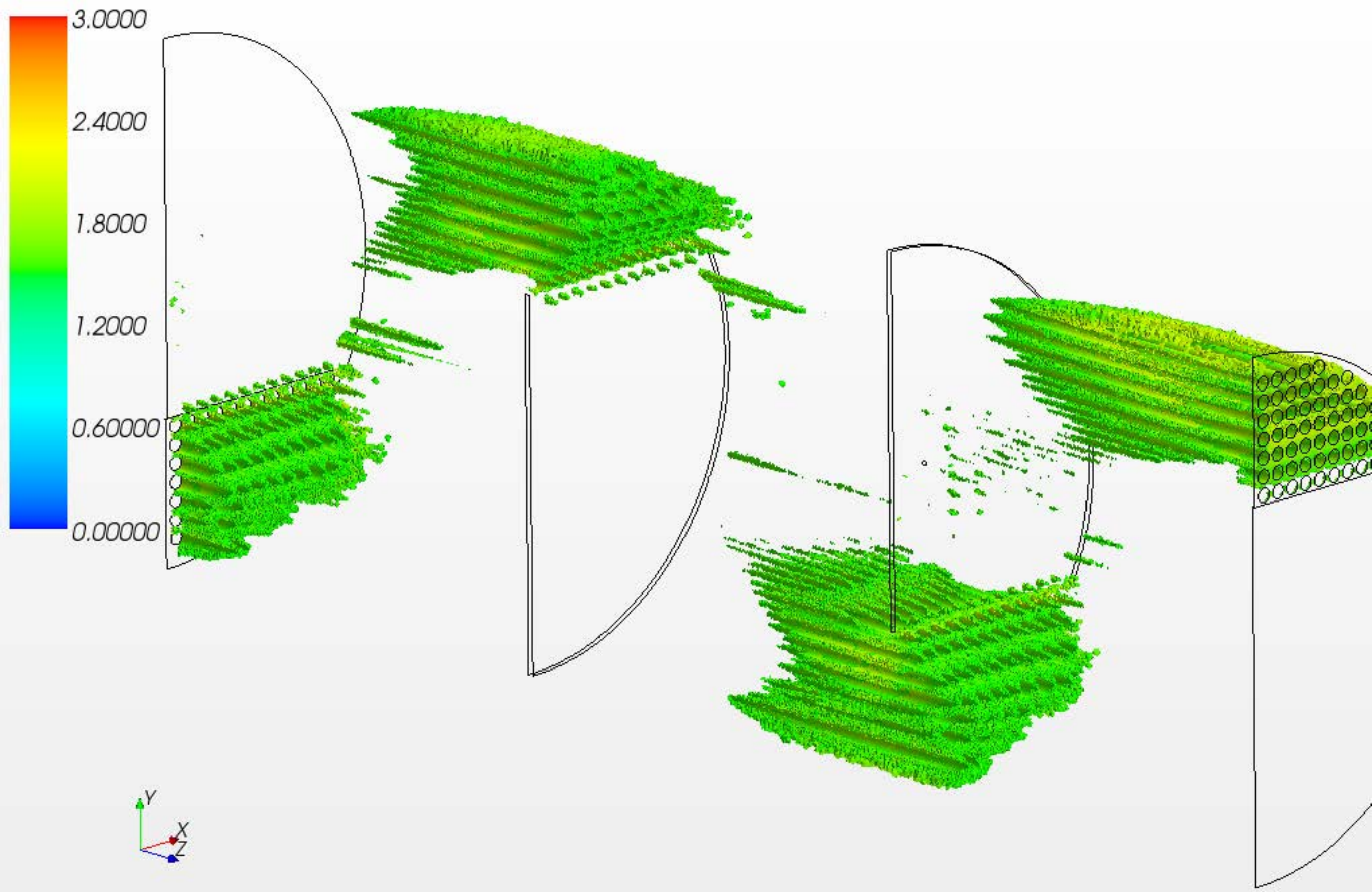

Velocity: Magnitude (m/s)

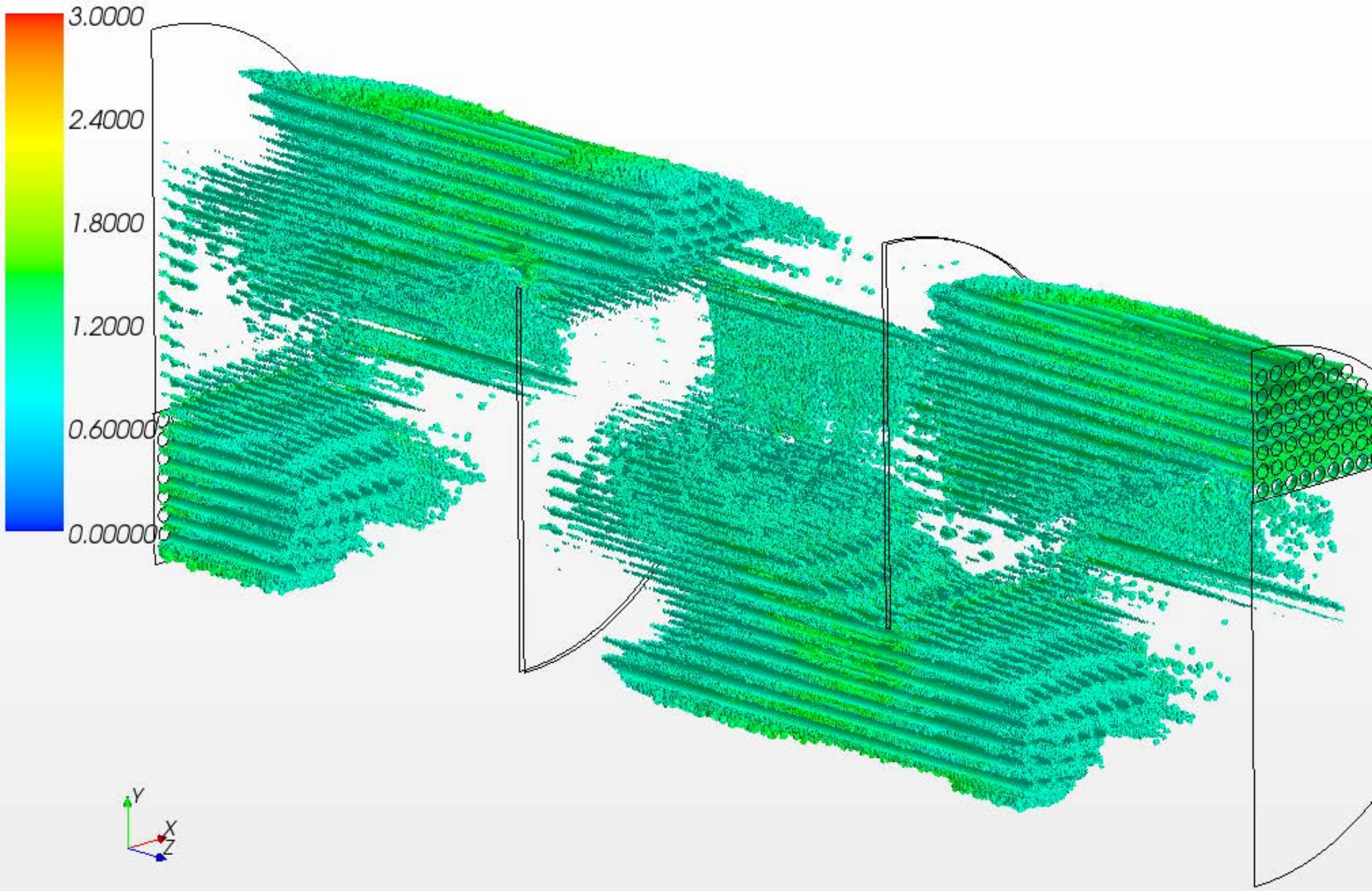

Velocity: Magnitude (m/s)

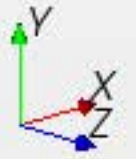
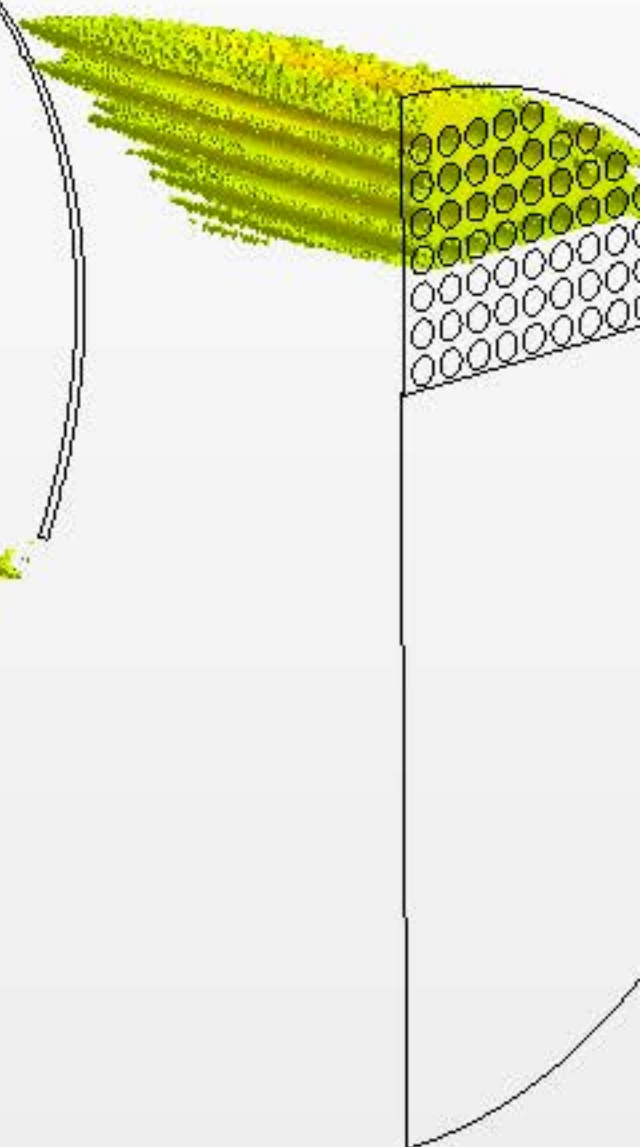
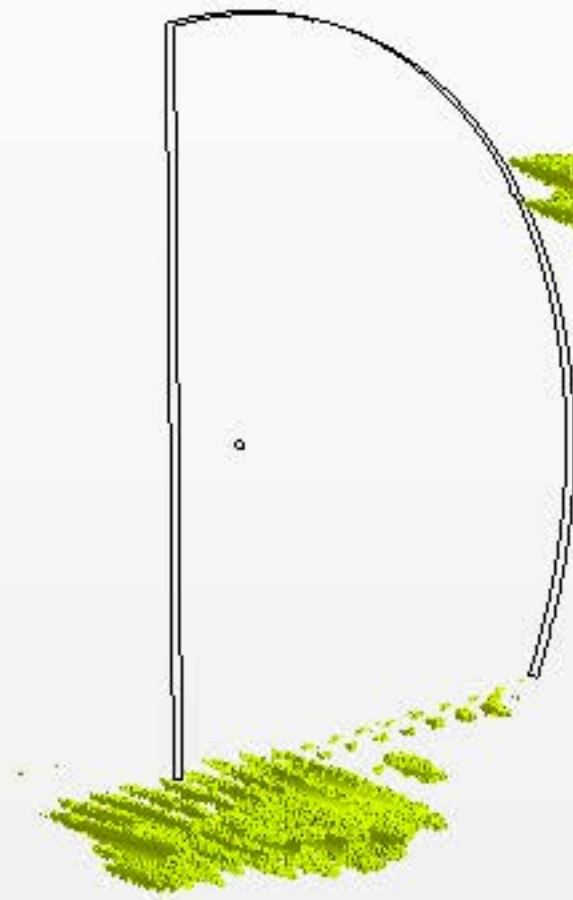
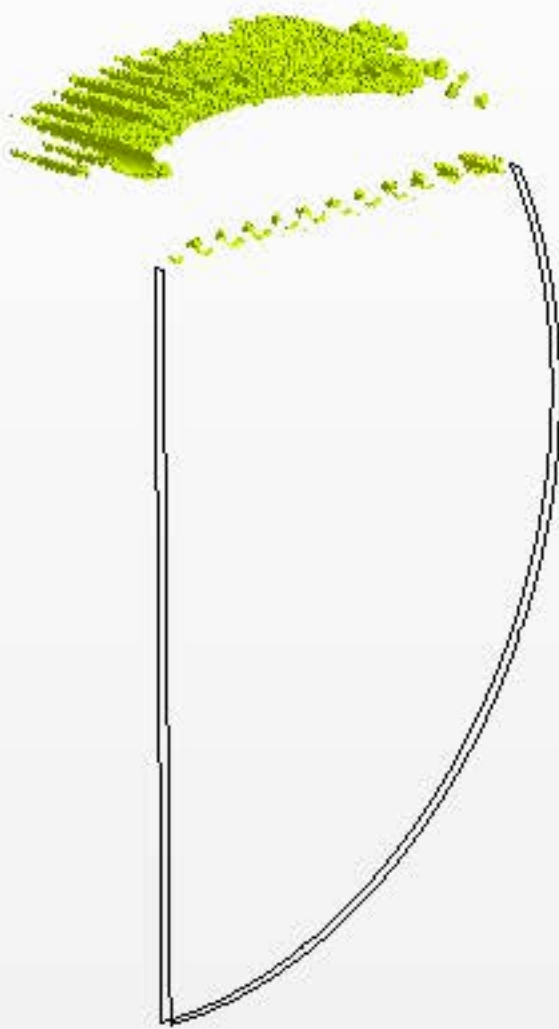
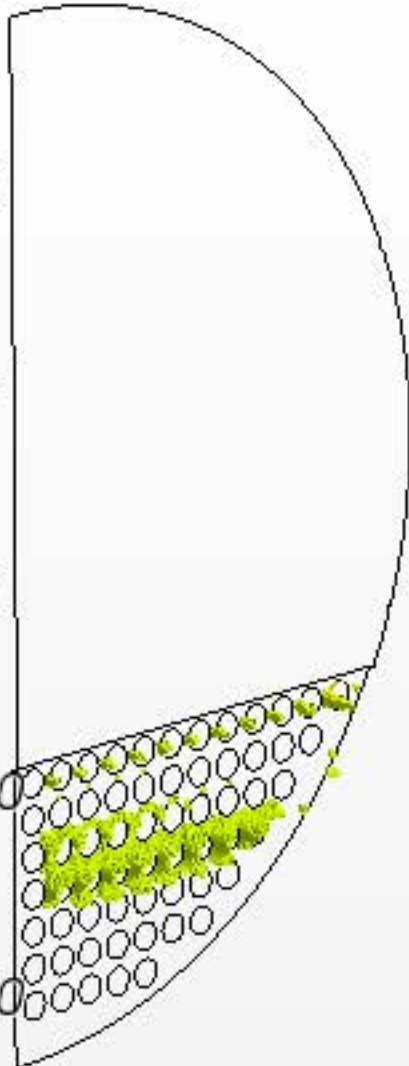
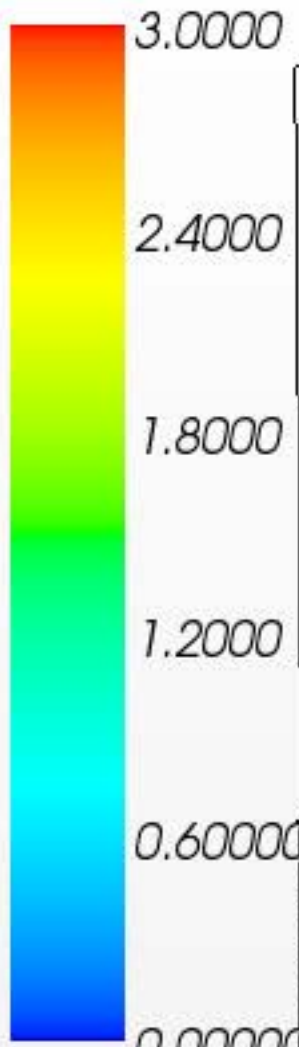

Velocity: Magnitude (m/s)

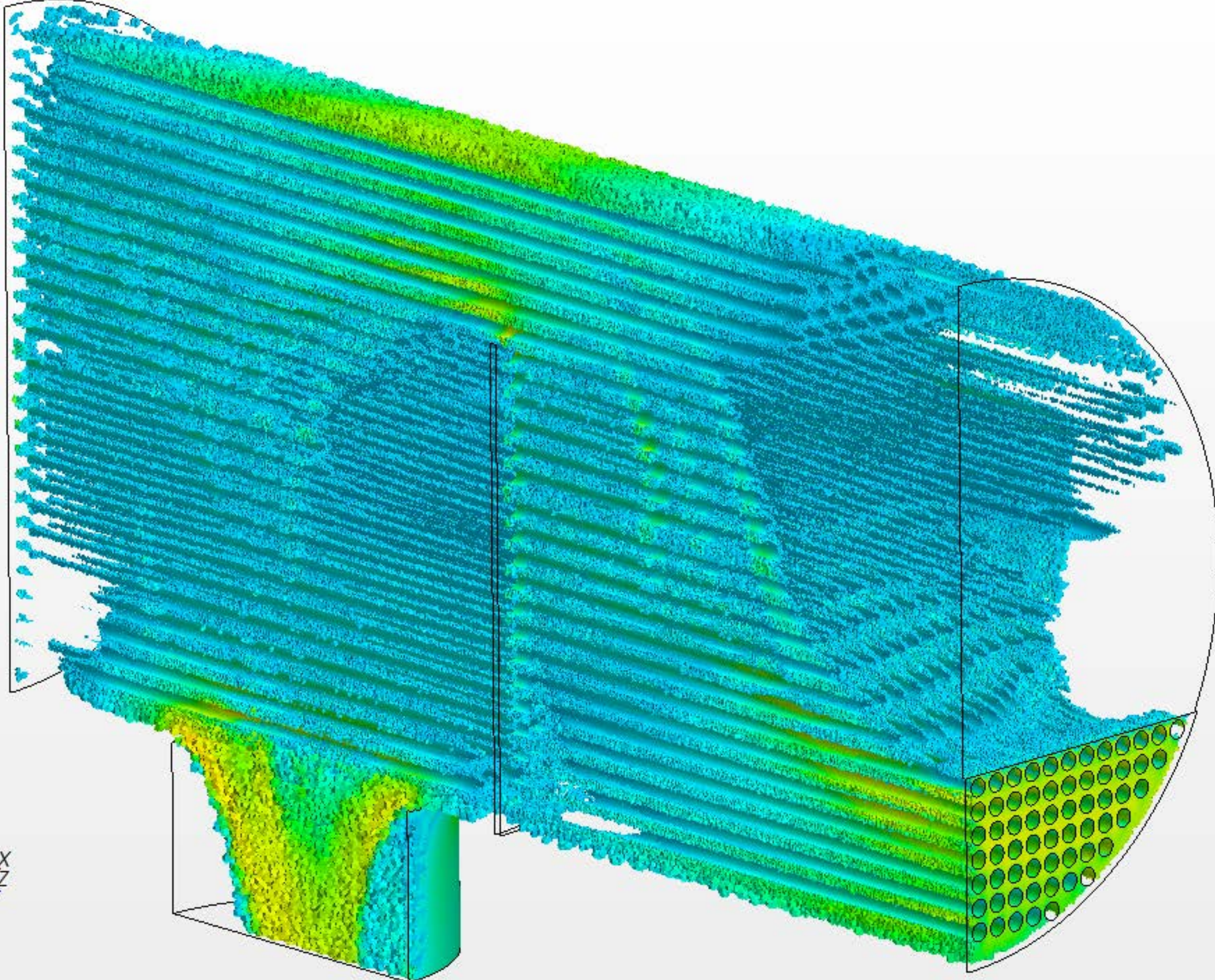
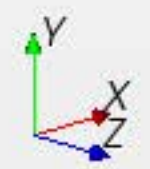

Velocity: Magnitude (m/s)

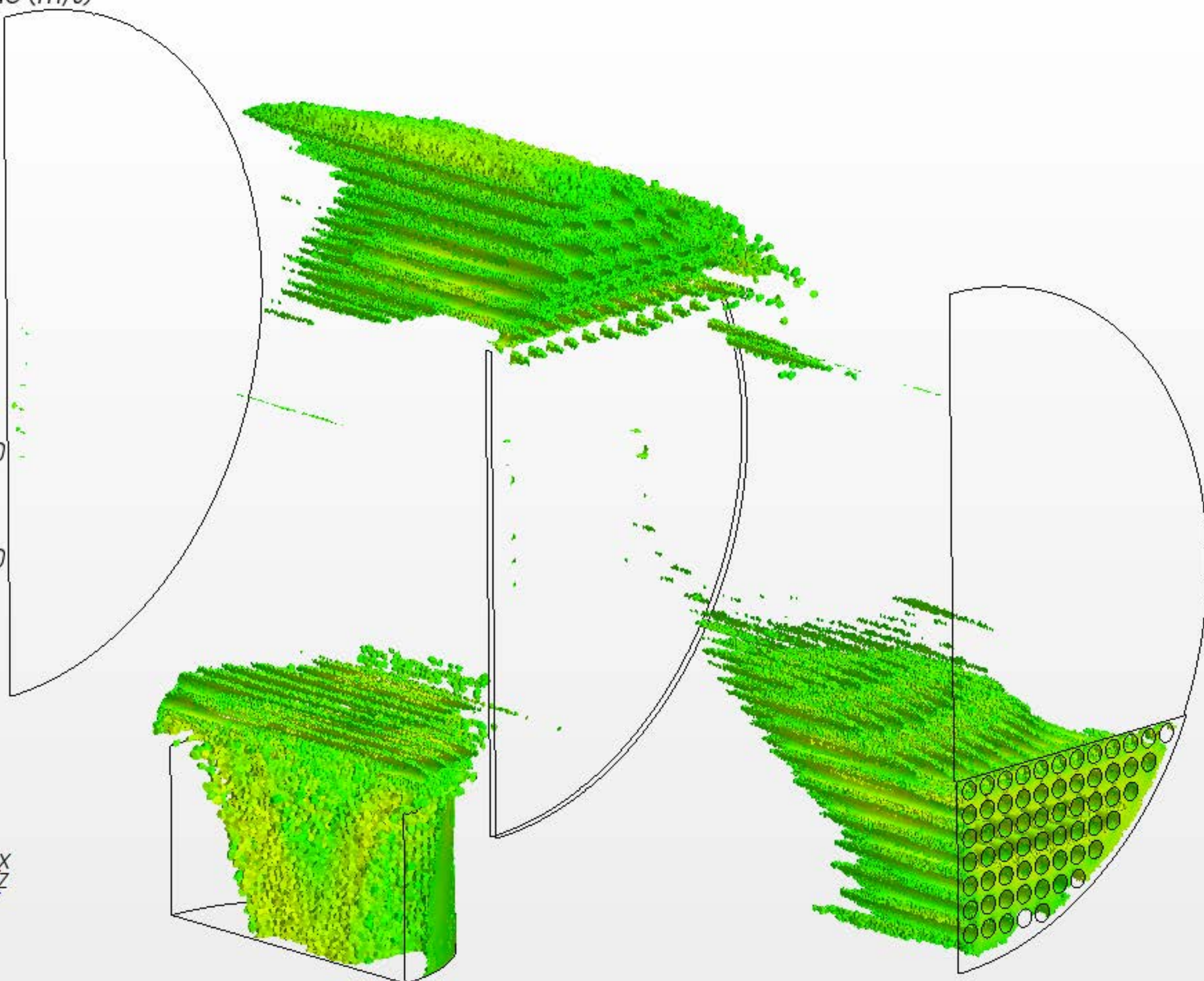
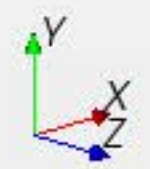
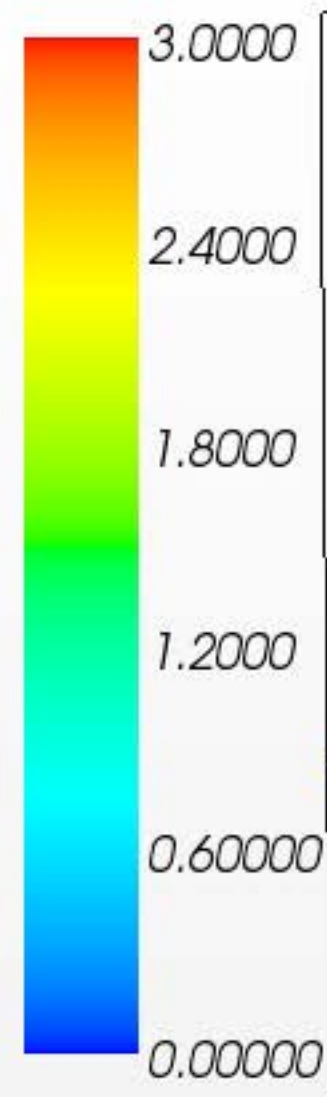

Velocity: Magnitude (m/s)

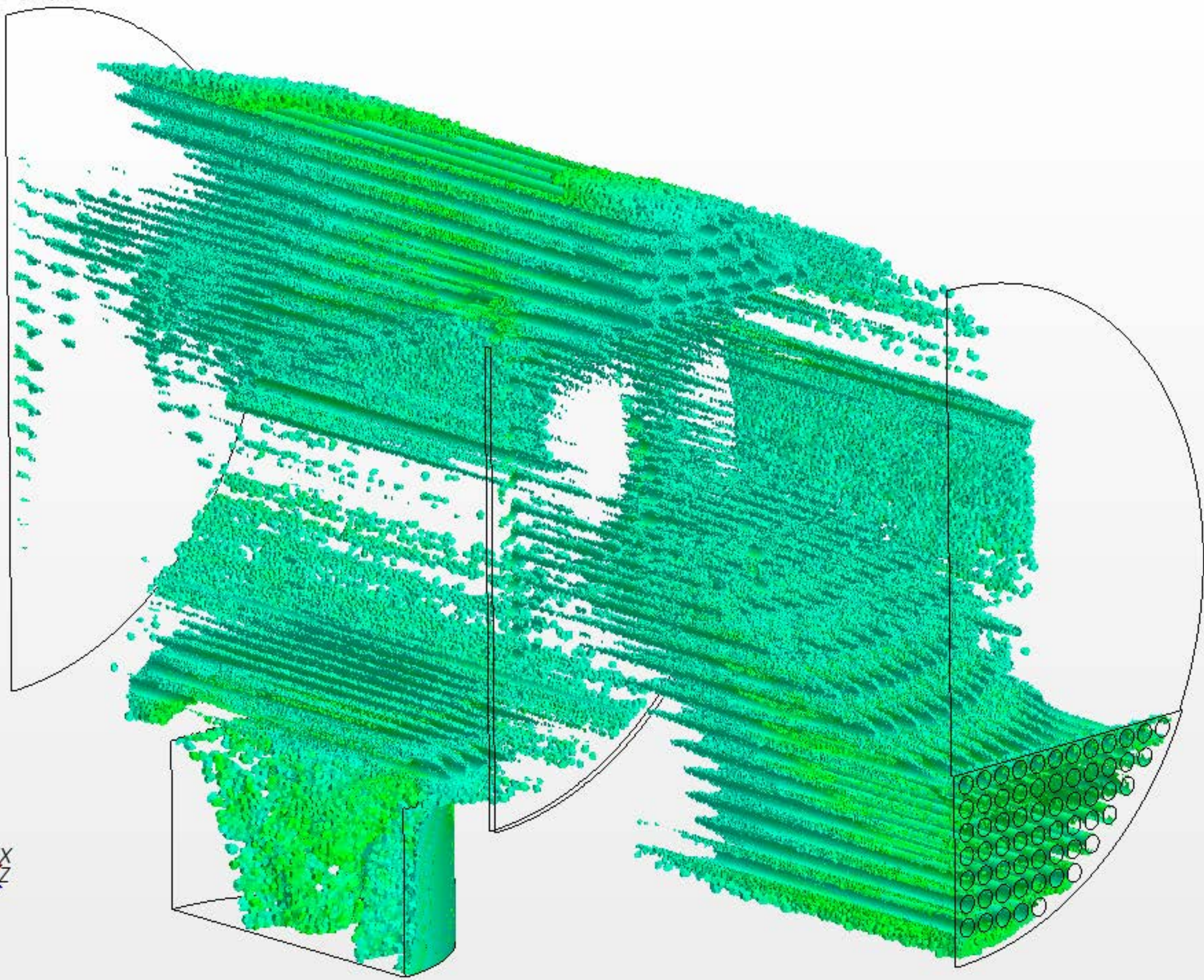
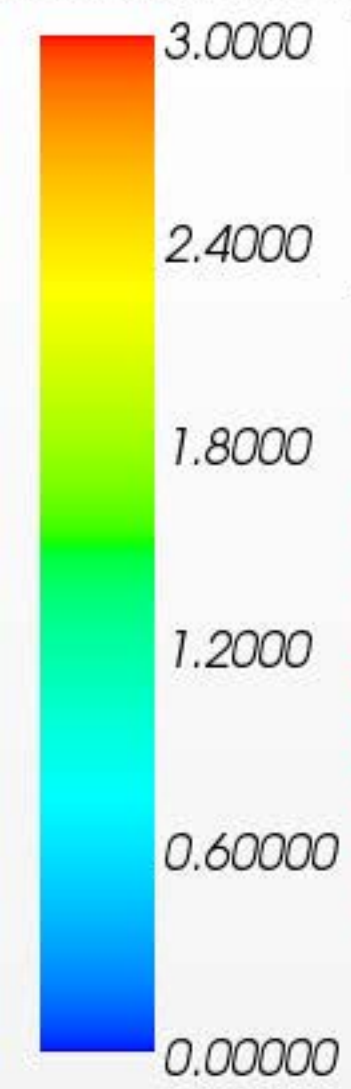

Velocity: Magnitude (m/s)

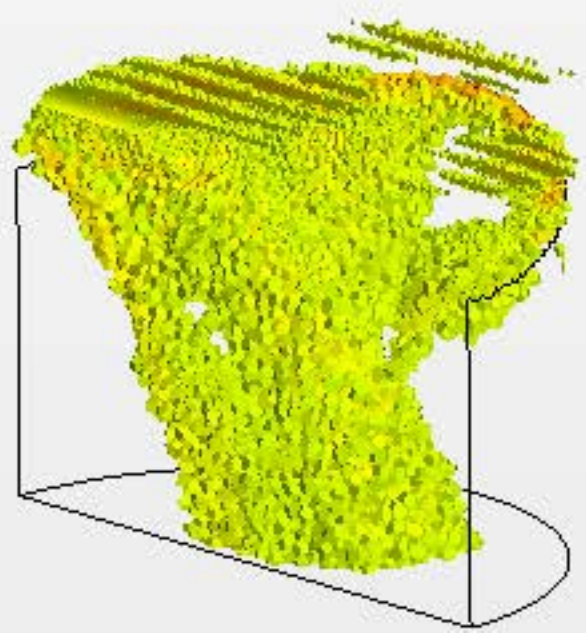
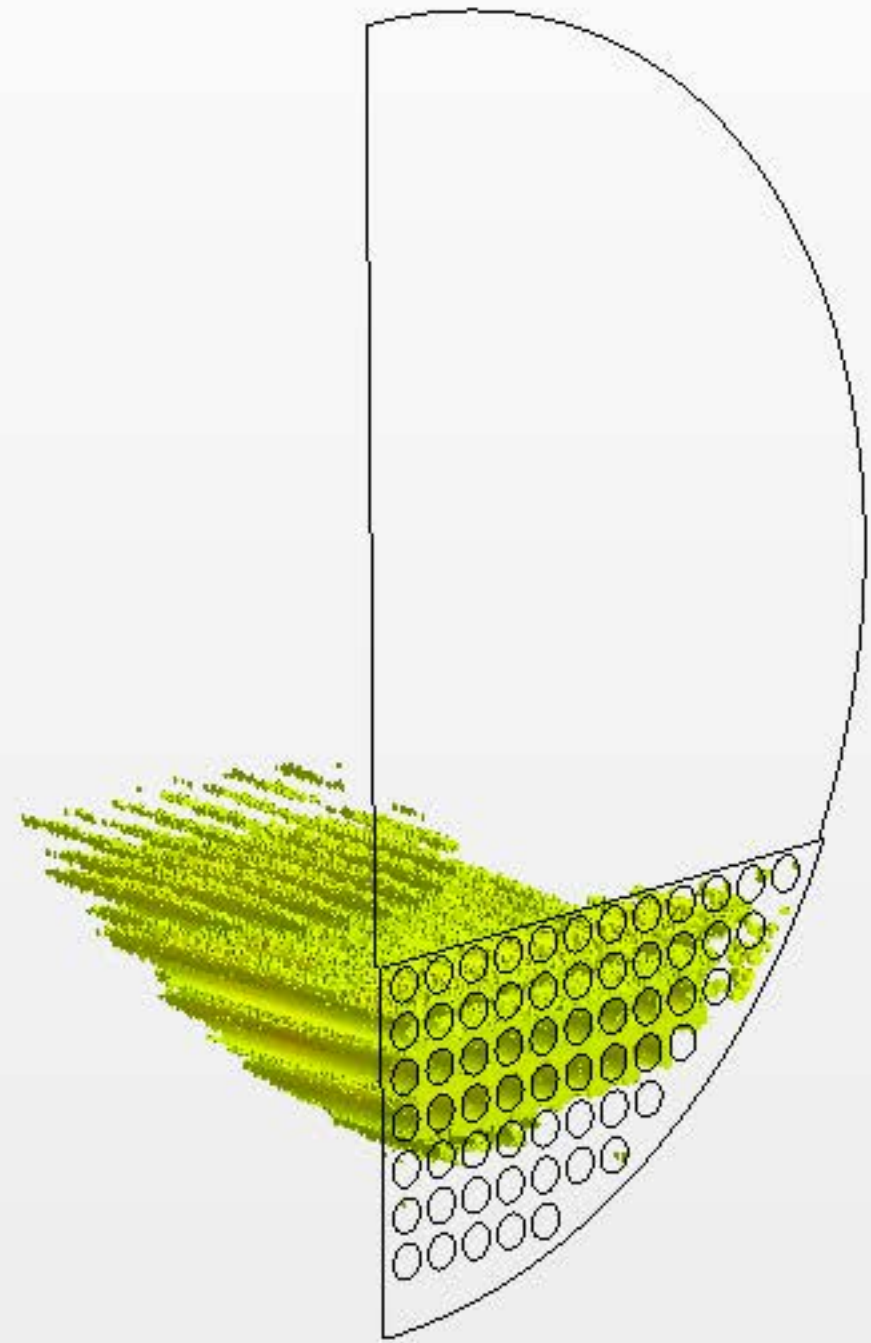
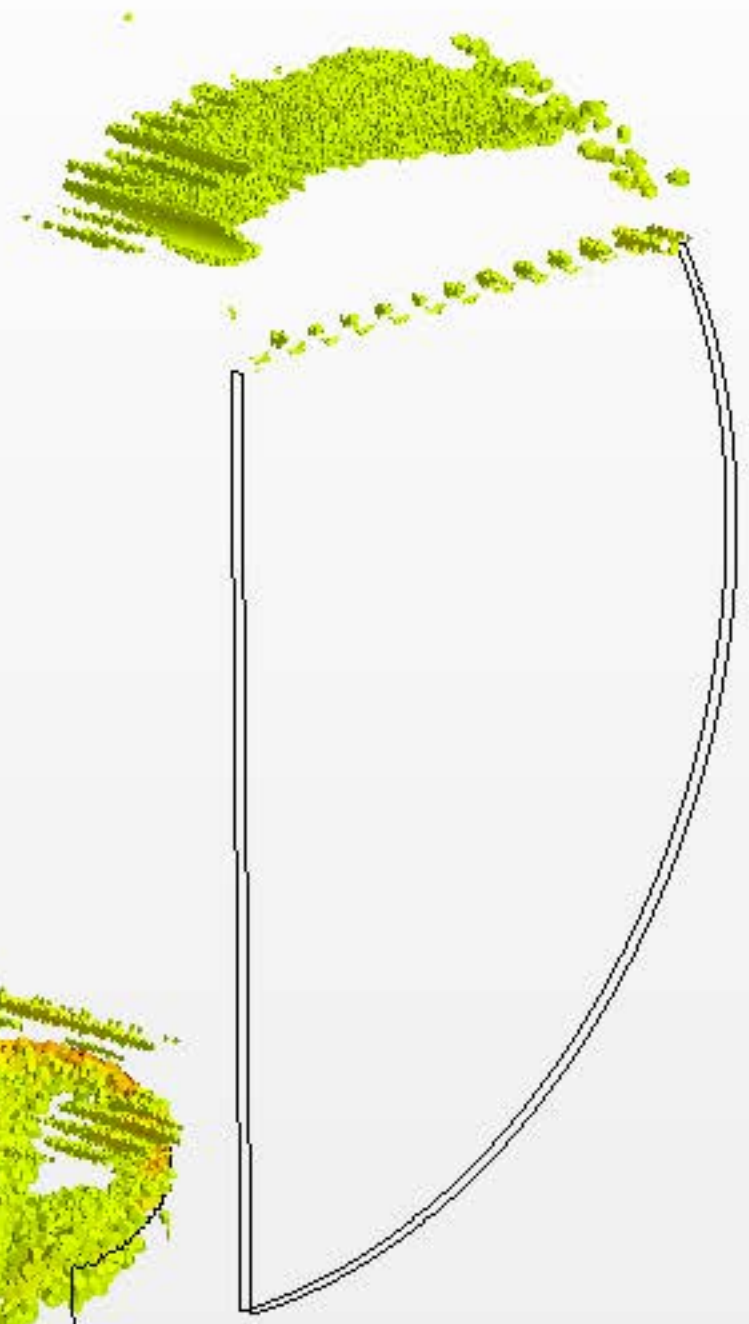
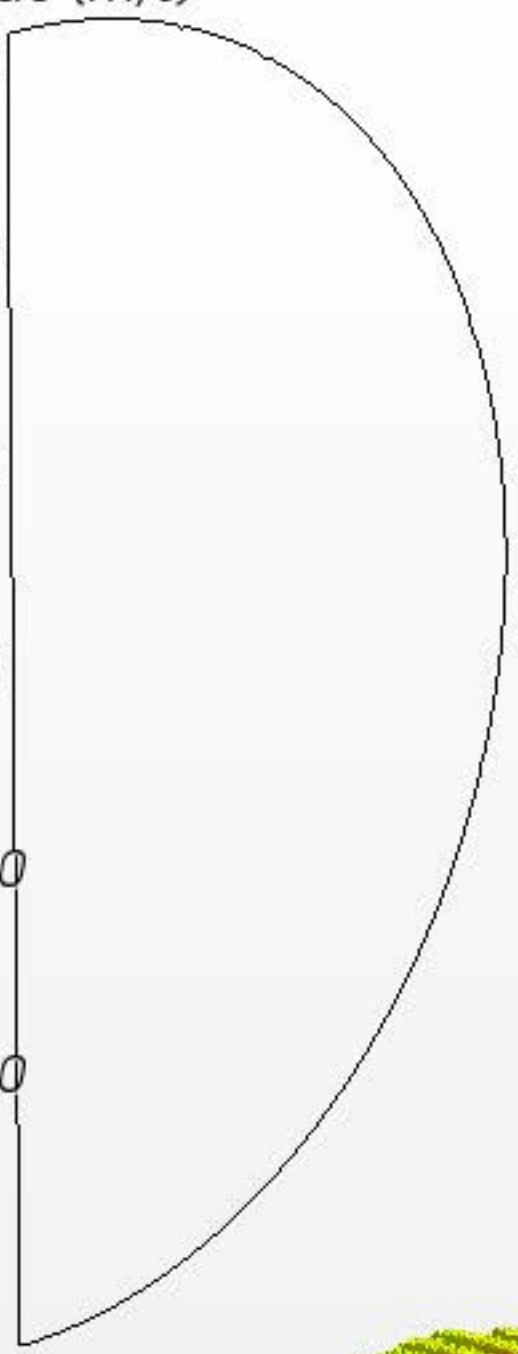
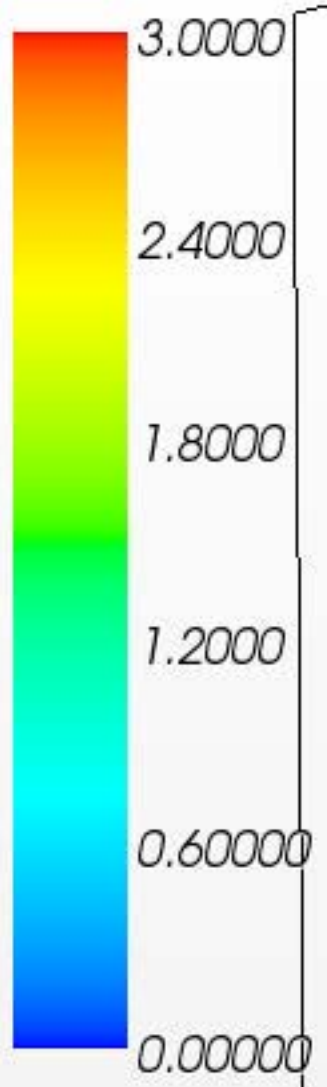

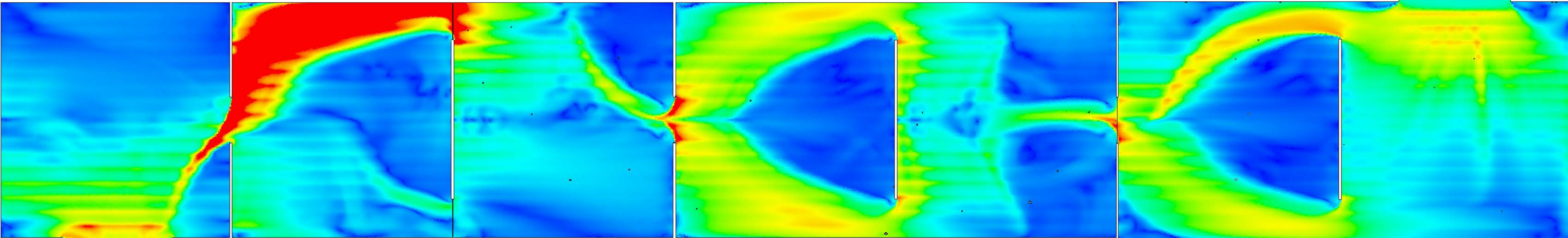

Velocity: Magnitude (m/s)

0.00000 0.60000 1.2000 1.8000 2.4000 3.0000



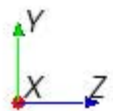
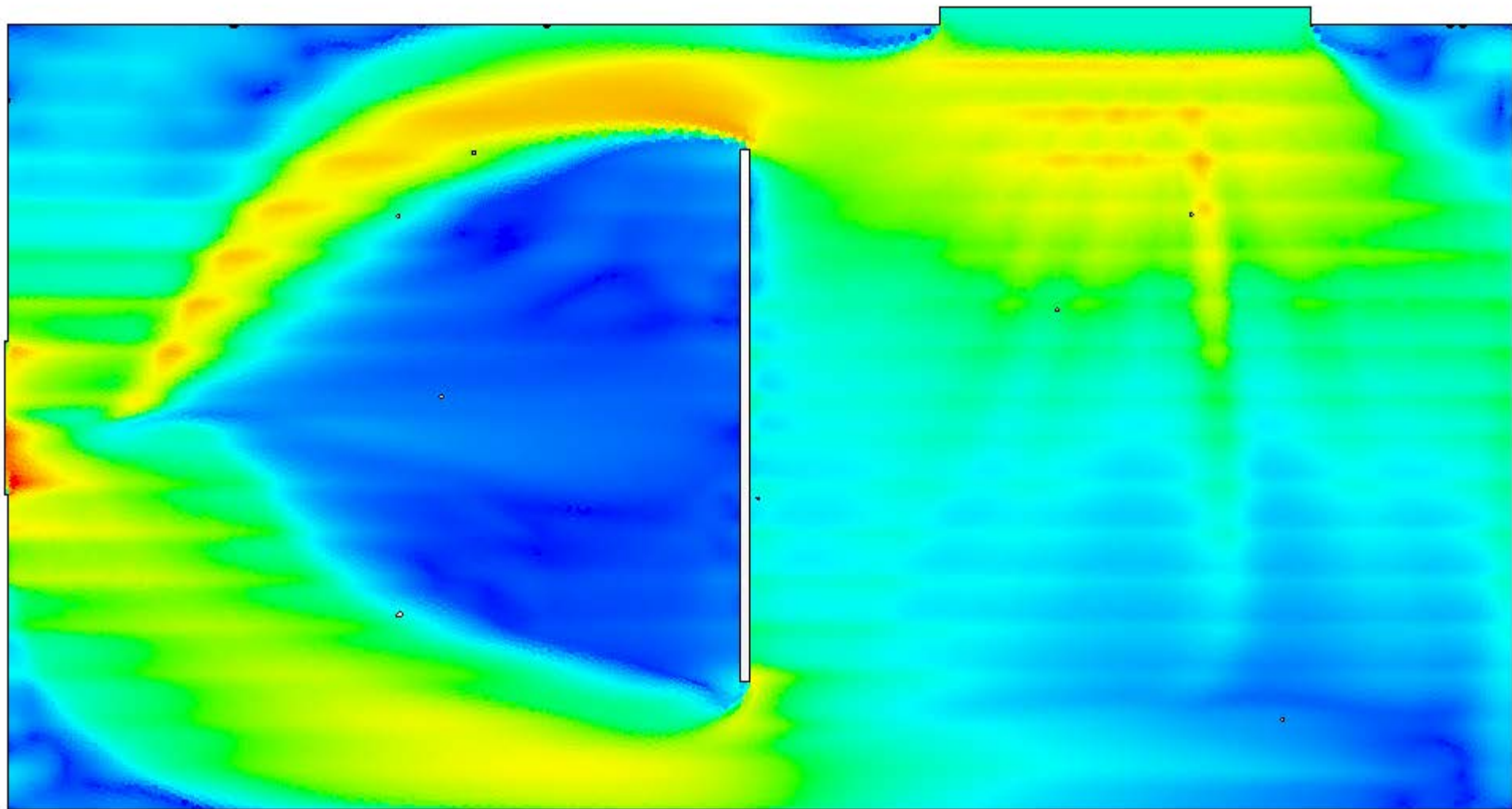

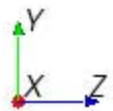
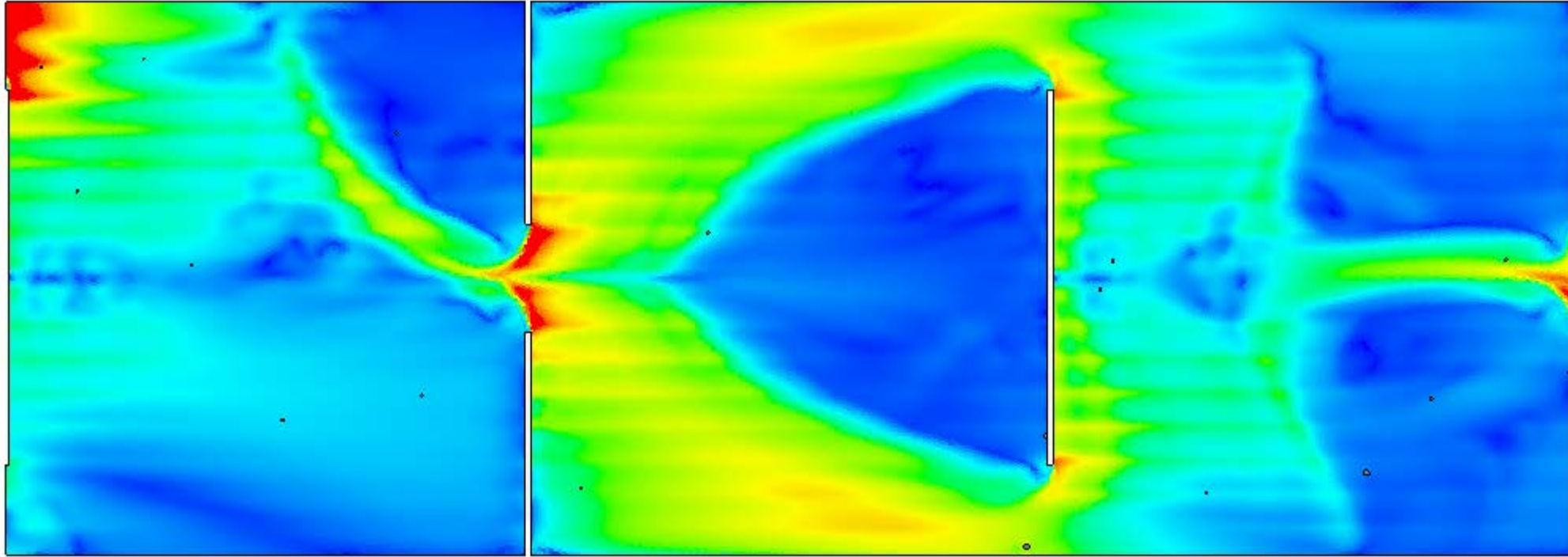

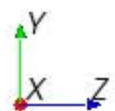
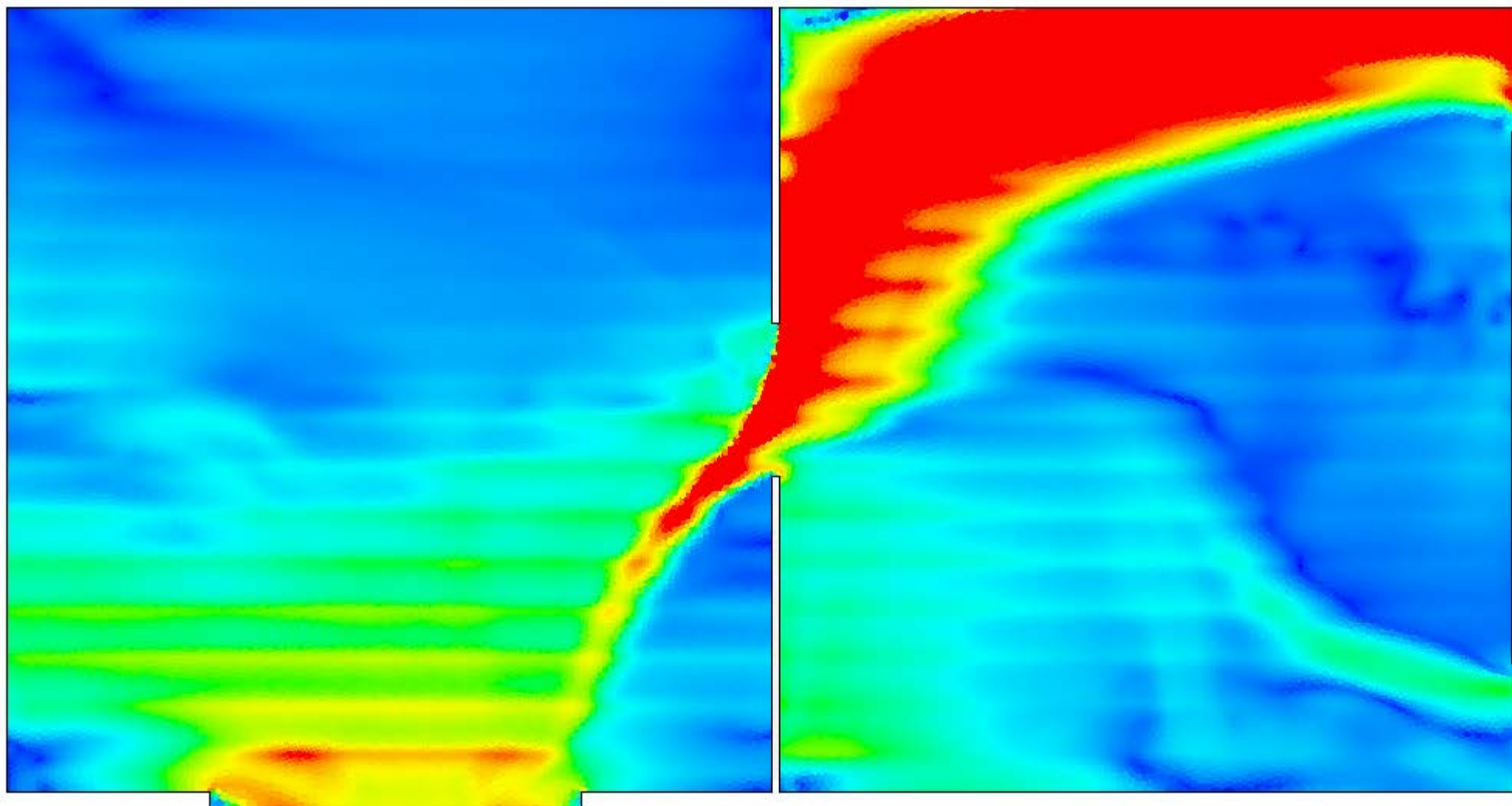

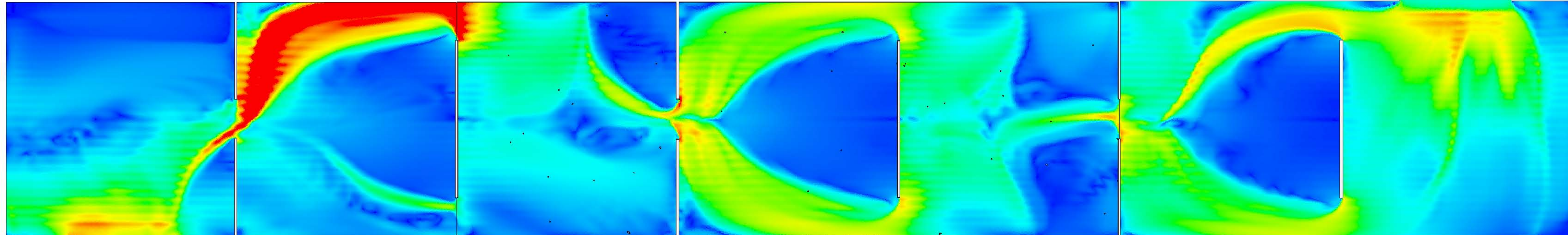

Velocity: Magnitude (m/s)

0.00000 0.60000 1.2000 1.8000 2.4000 3.0000



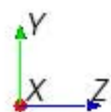
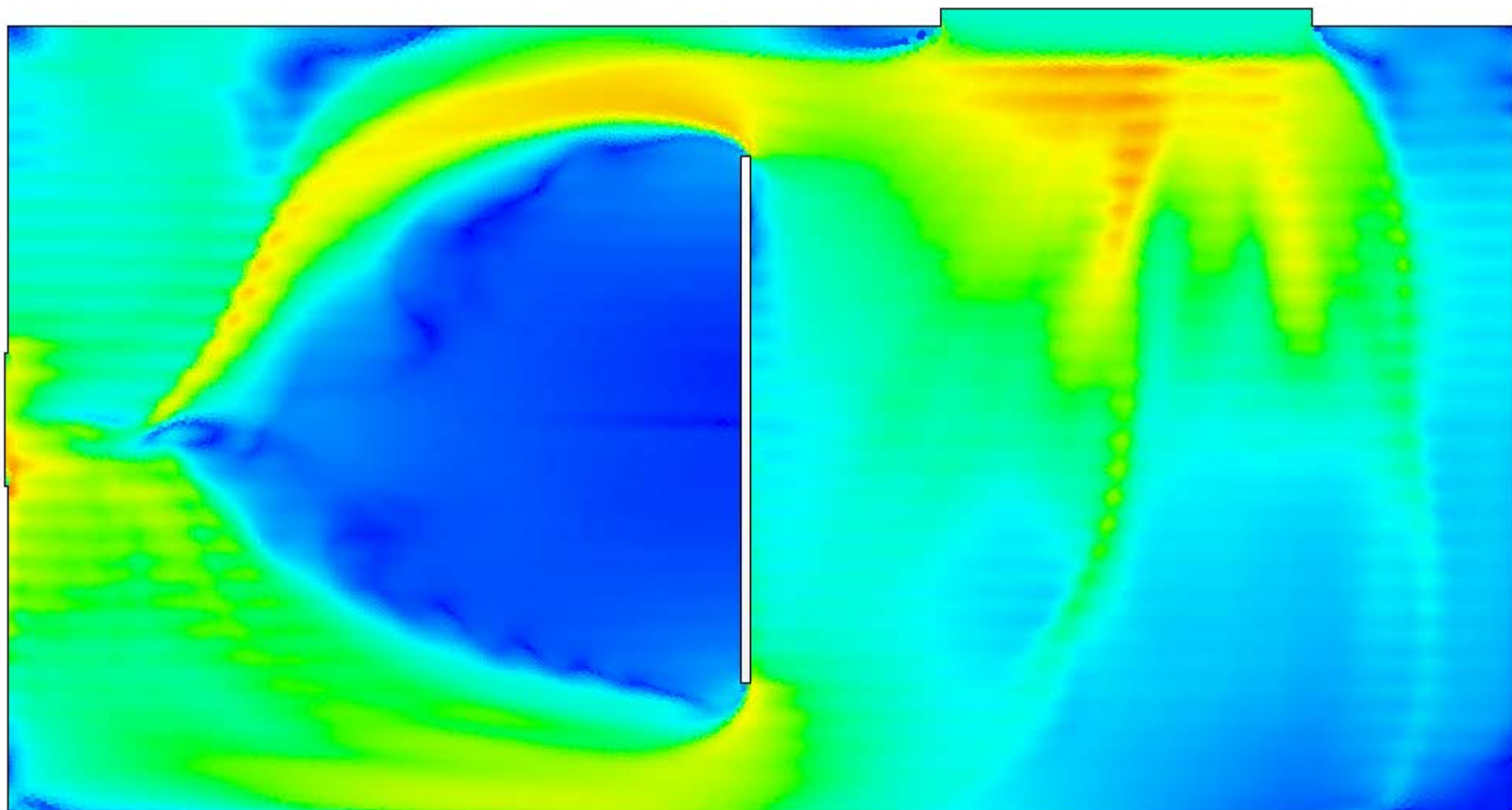

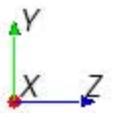
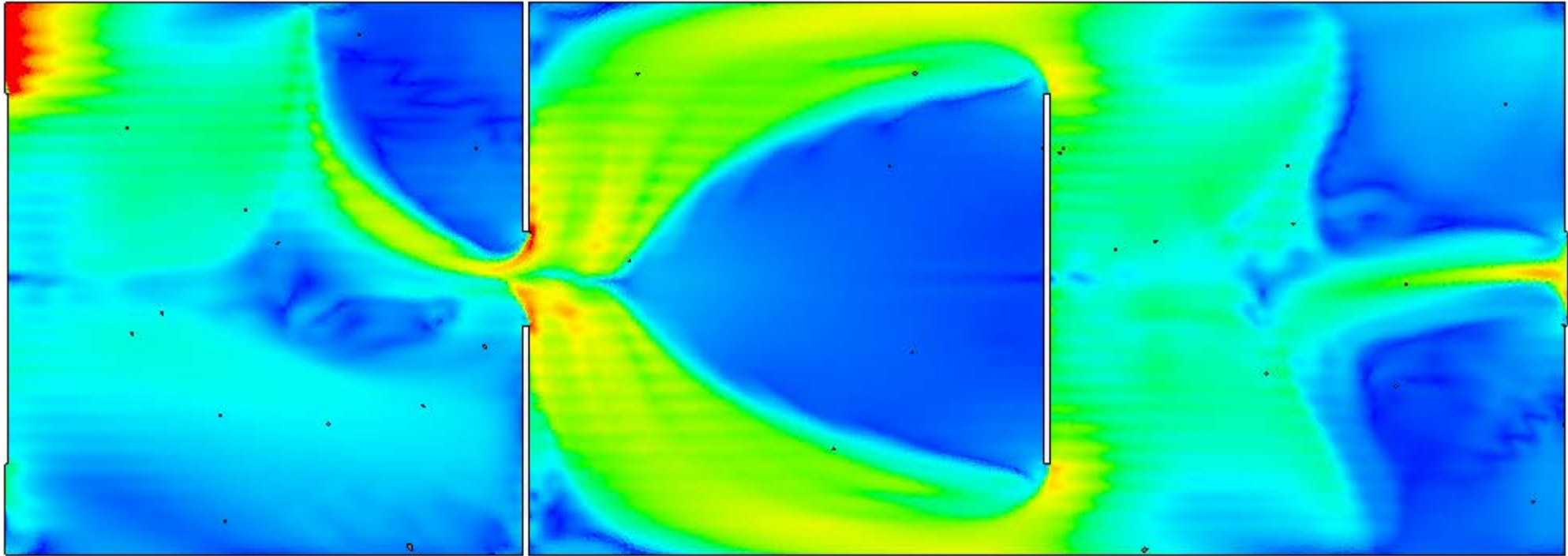

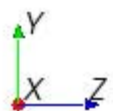
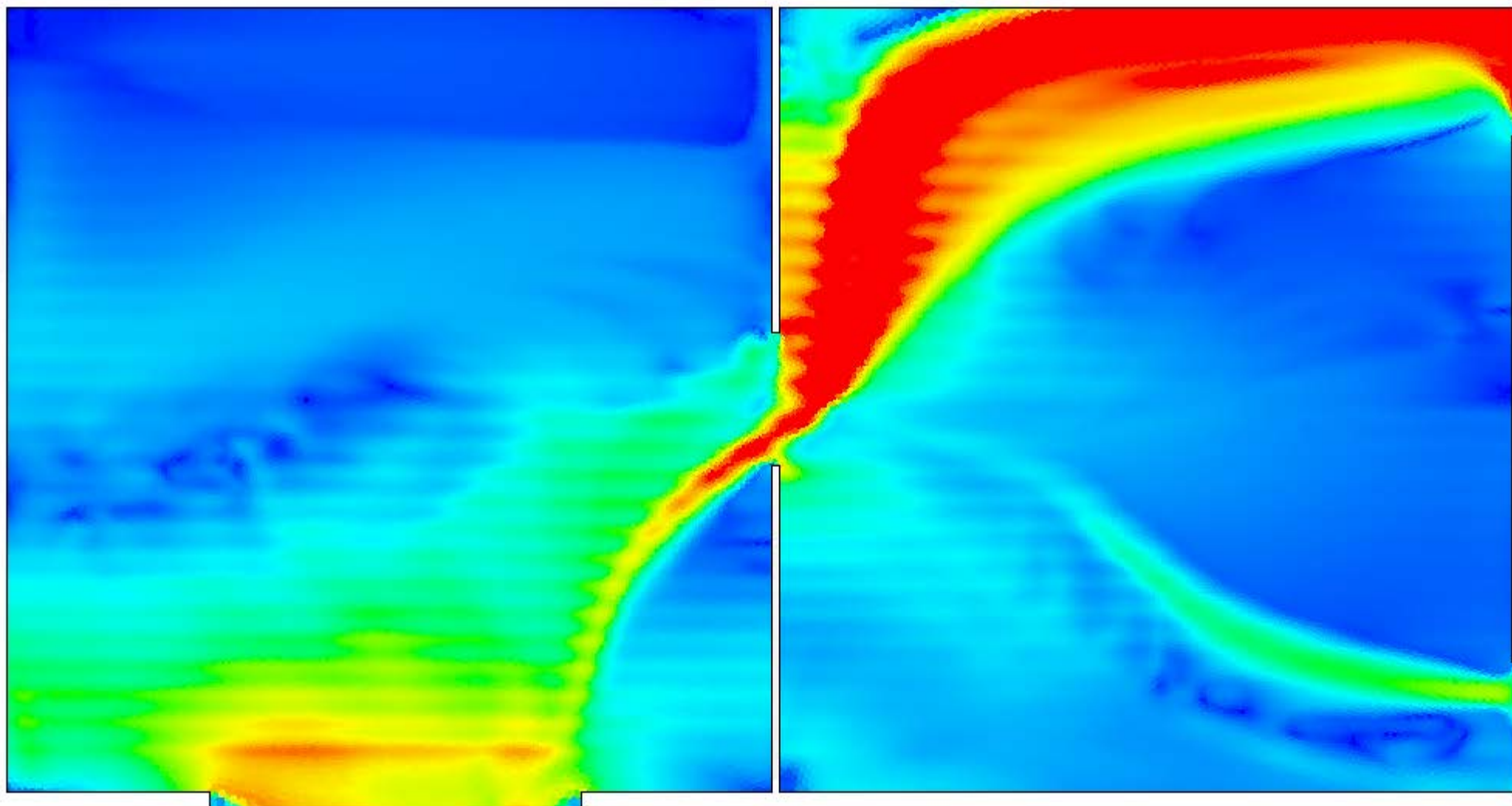

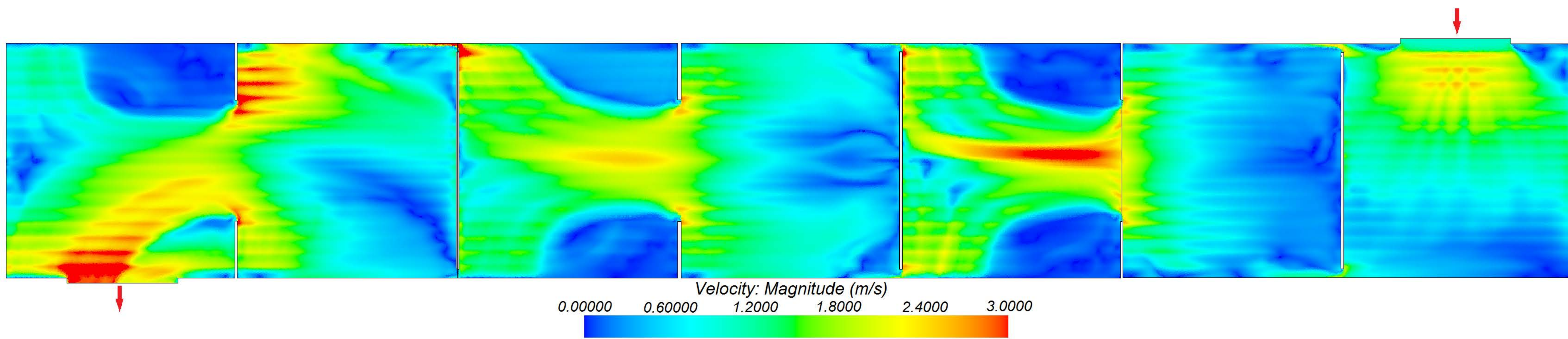

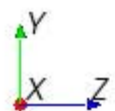
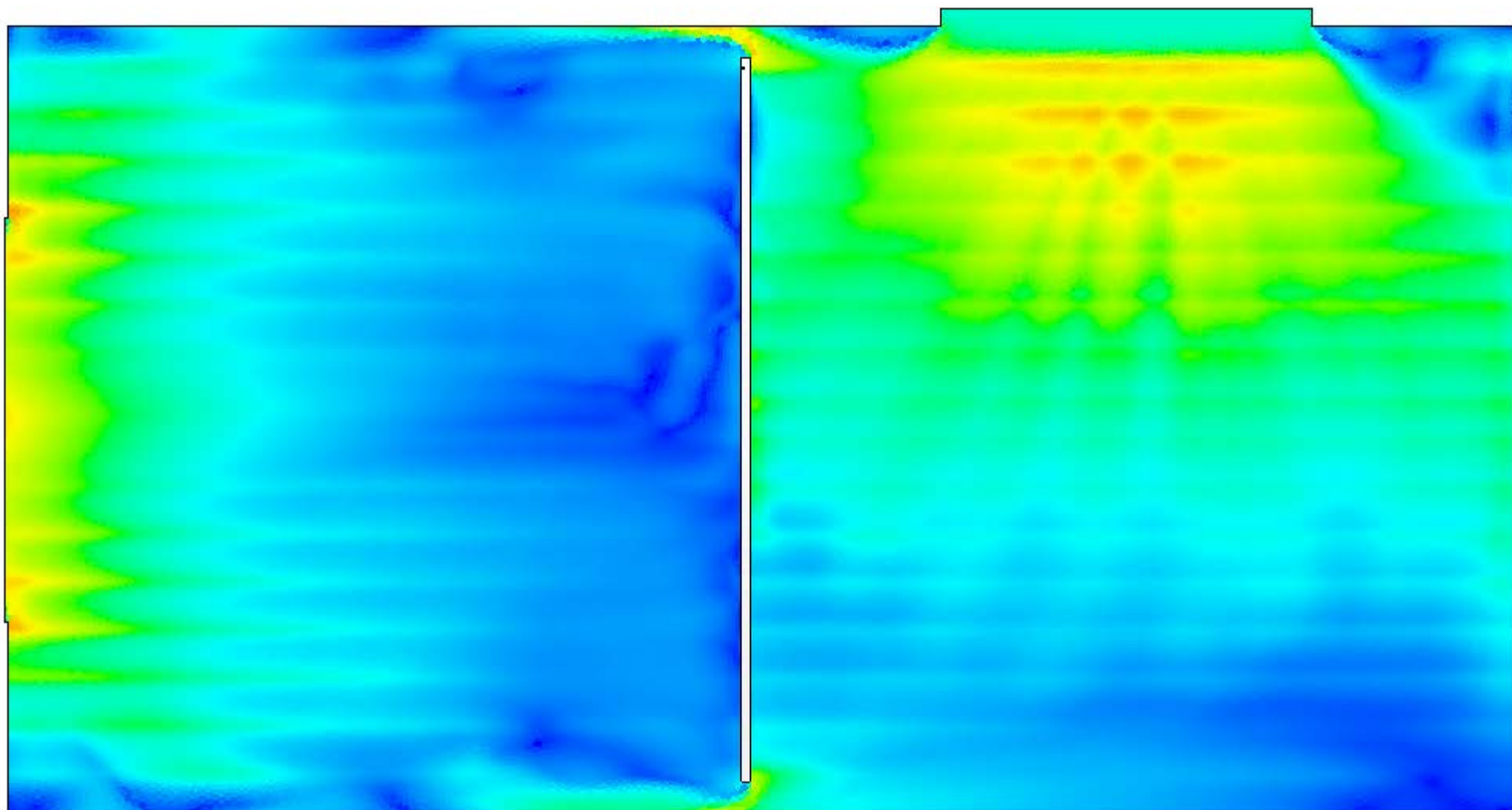

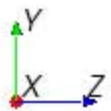
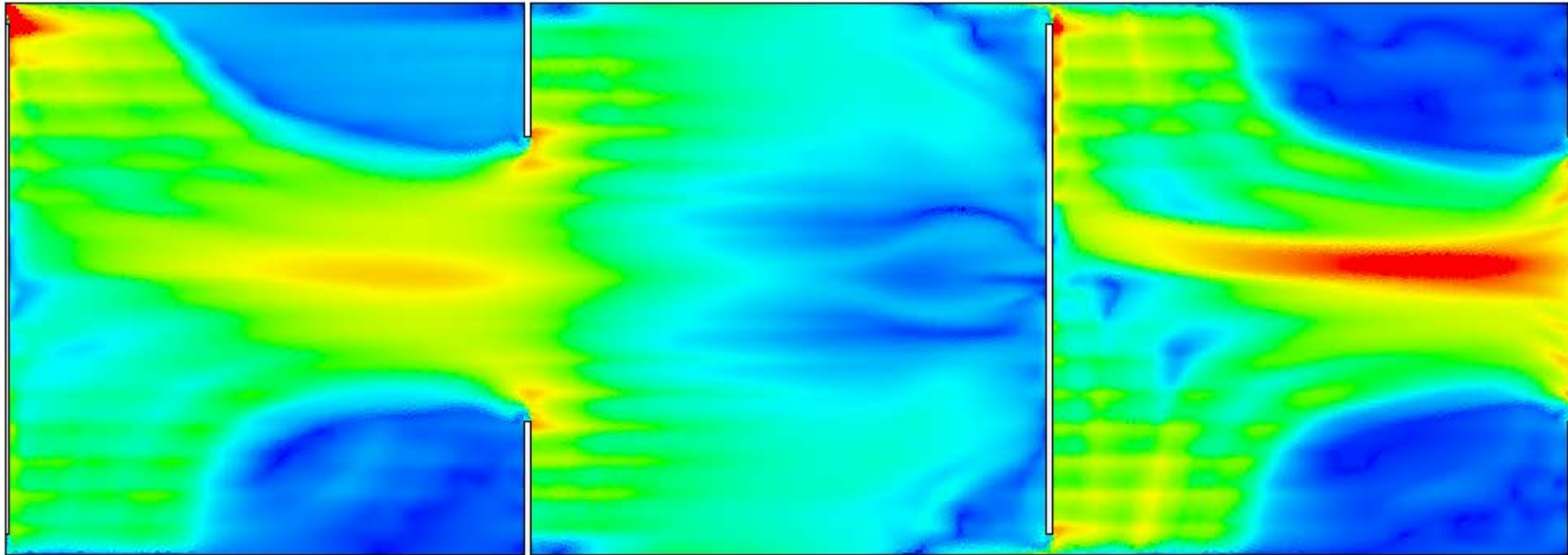

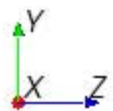
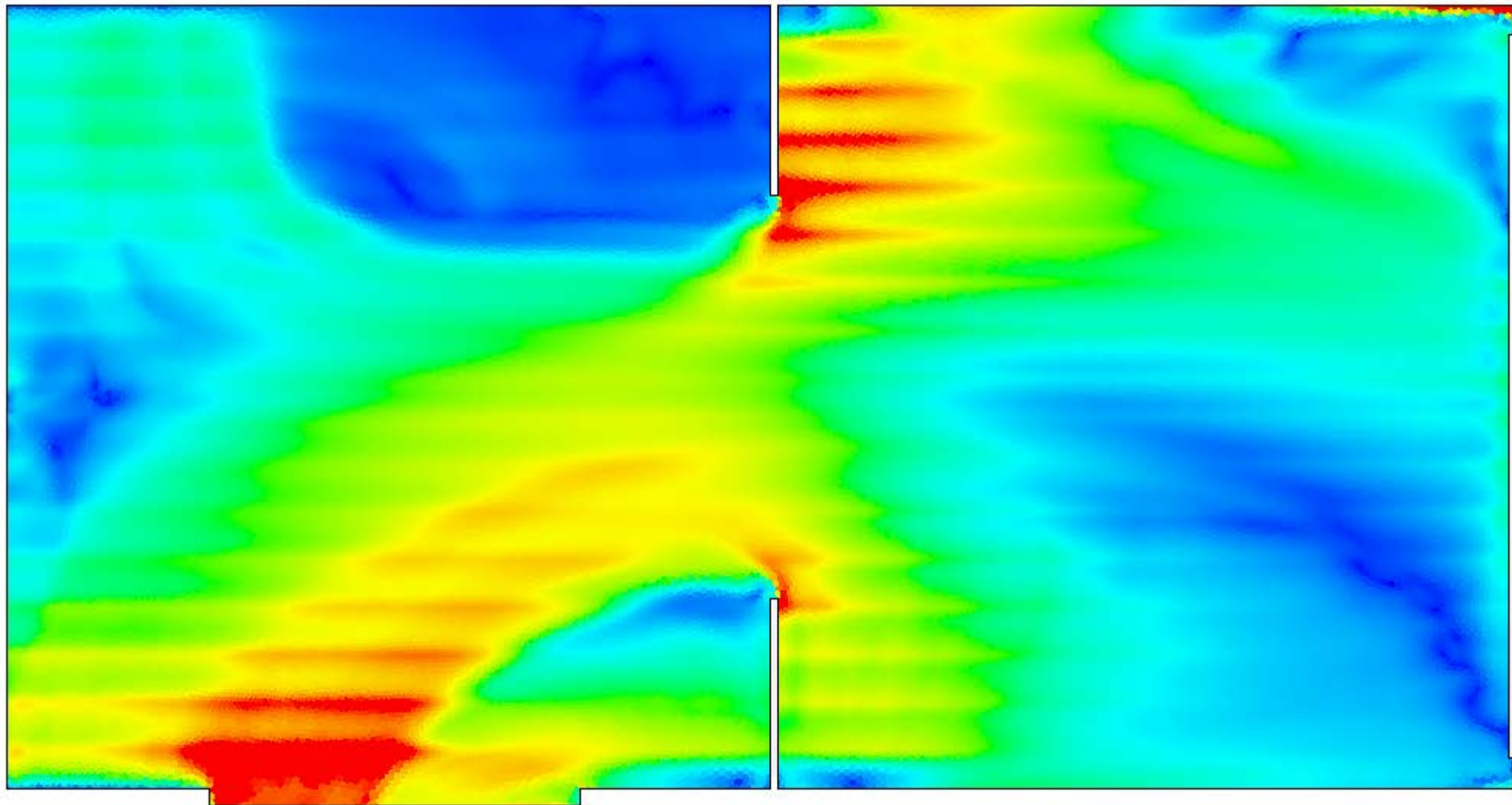

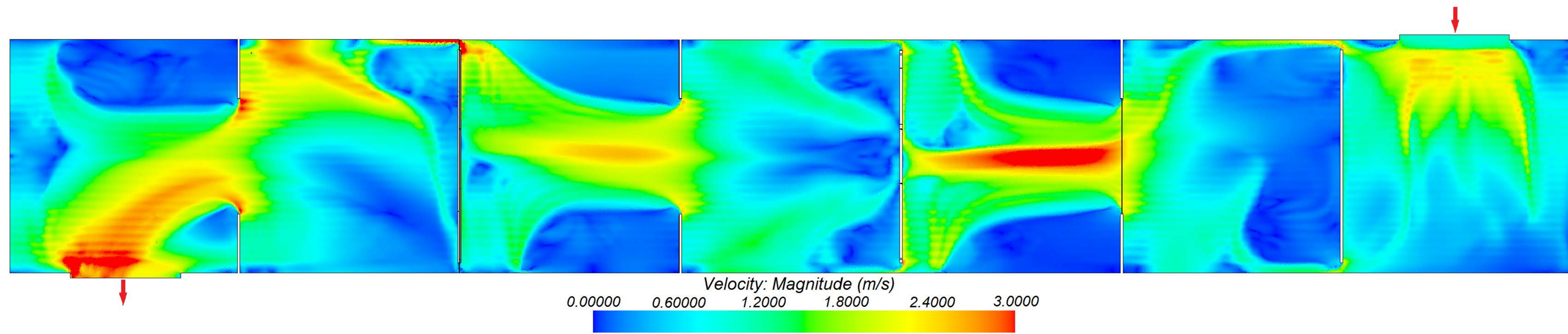

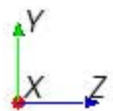
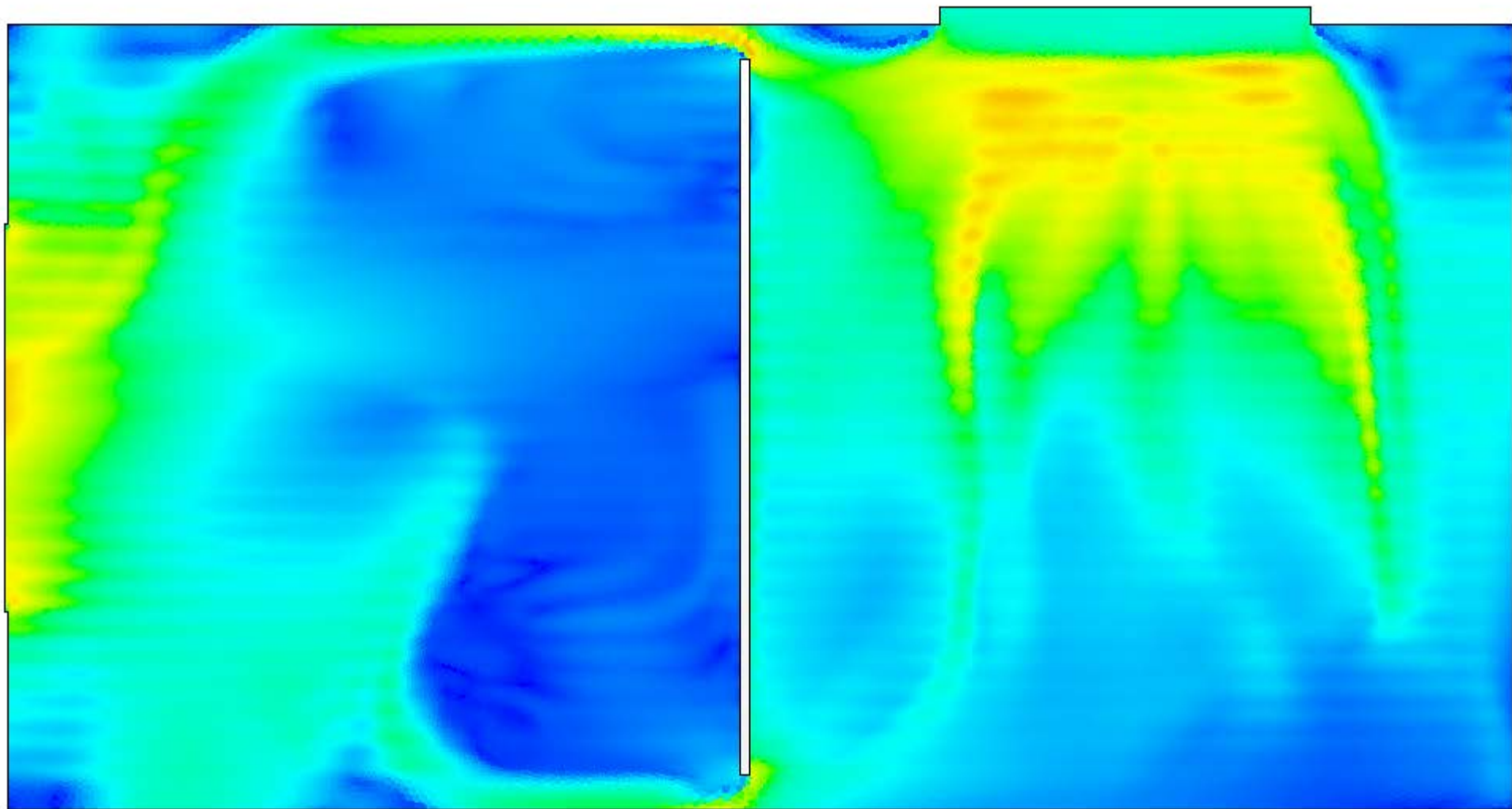

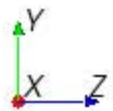
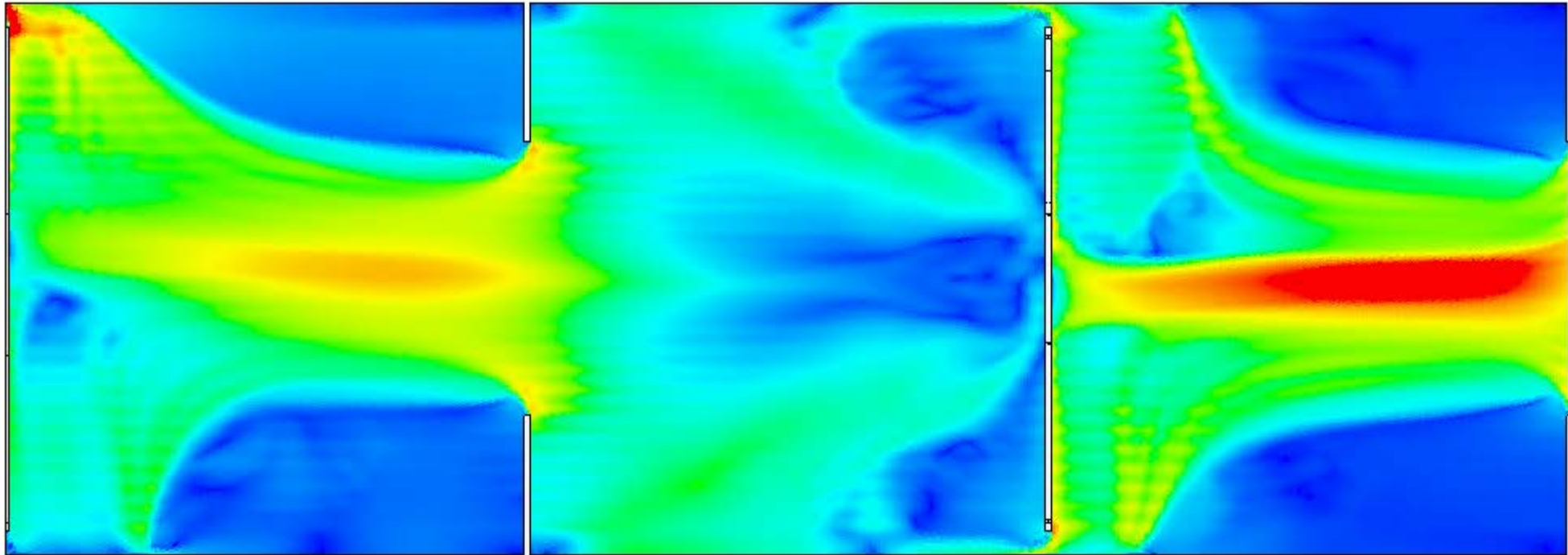

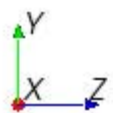
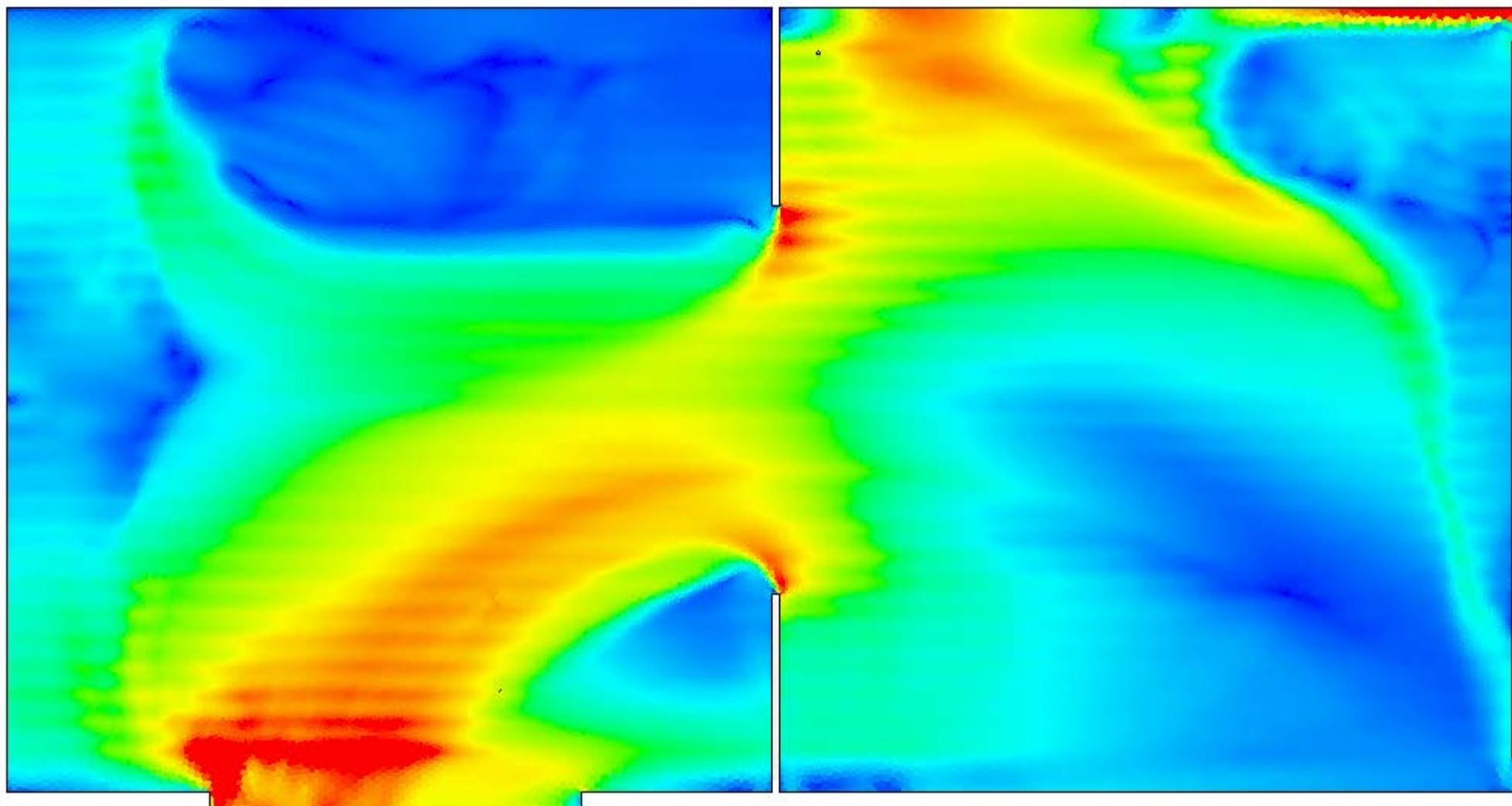

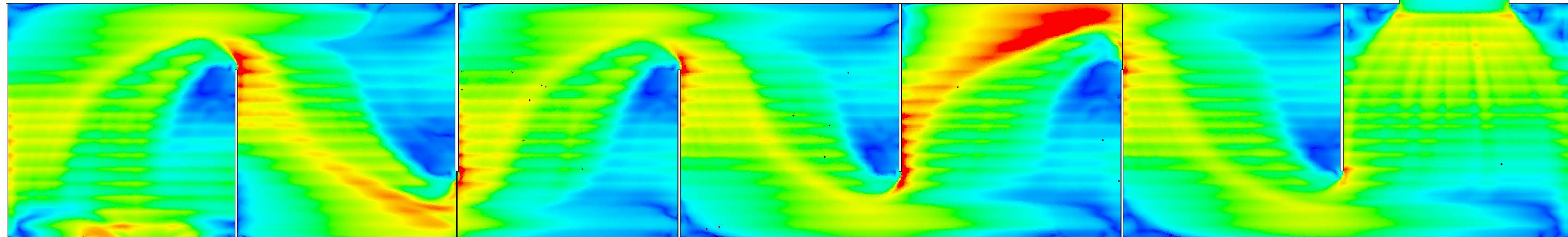

Velocity: Magnitude (m/s)

0.00000 0.60000 1.2000 1.8000 2.4000 3.0000



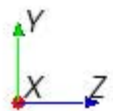
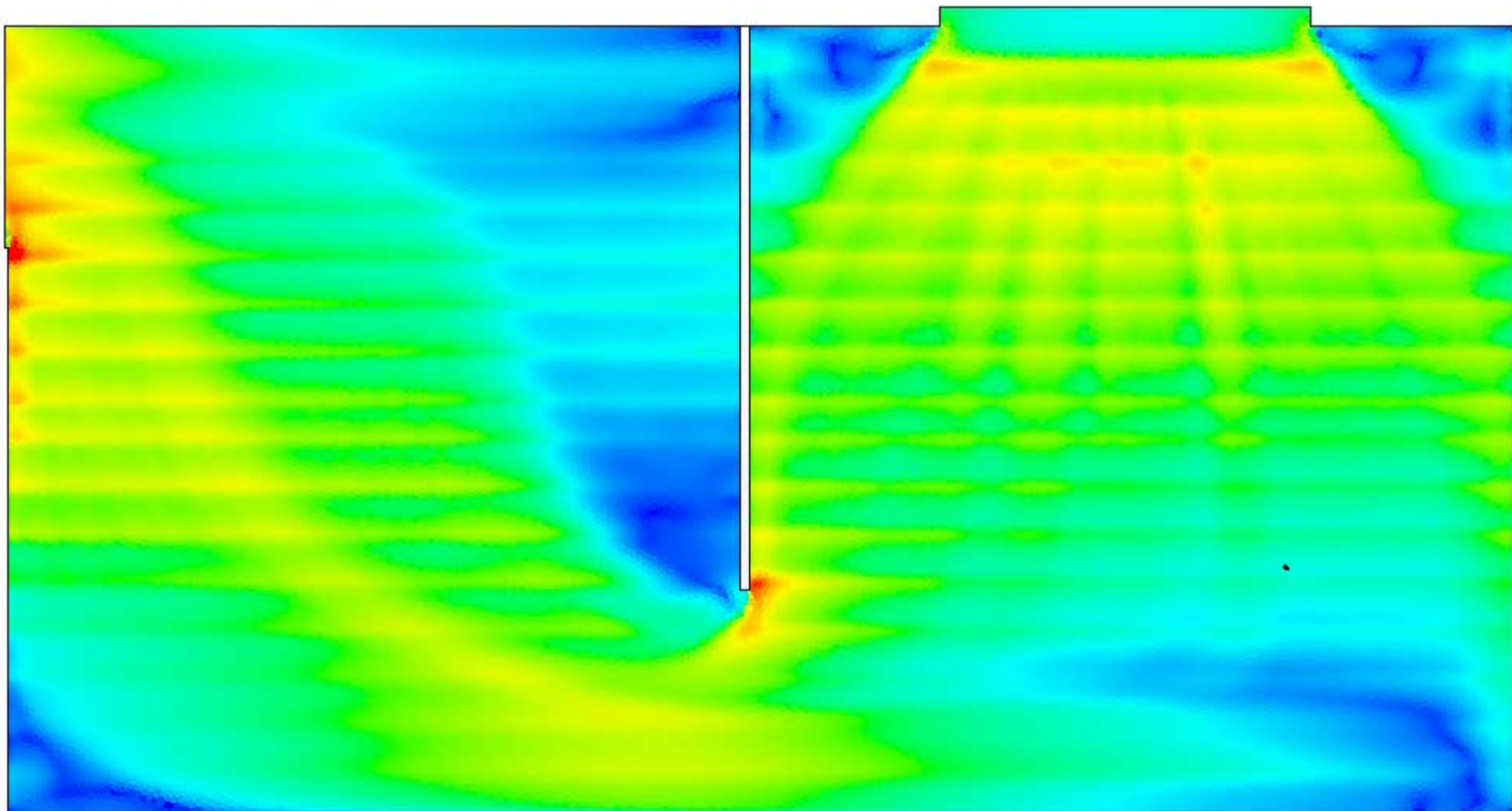

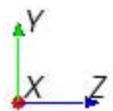
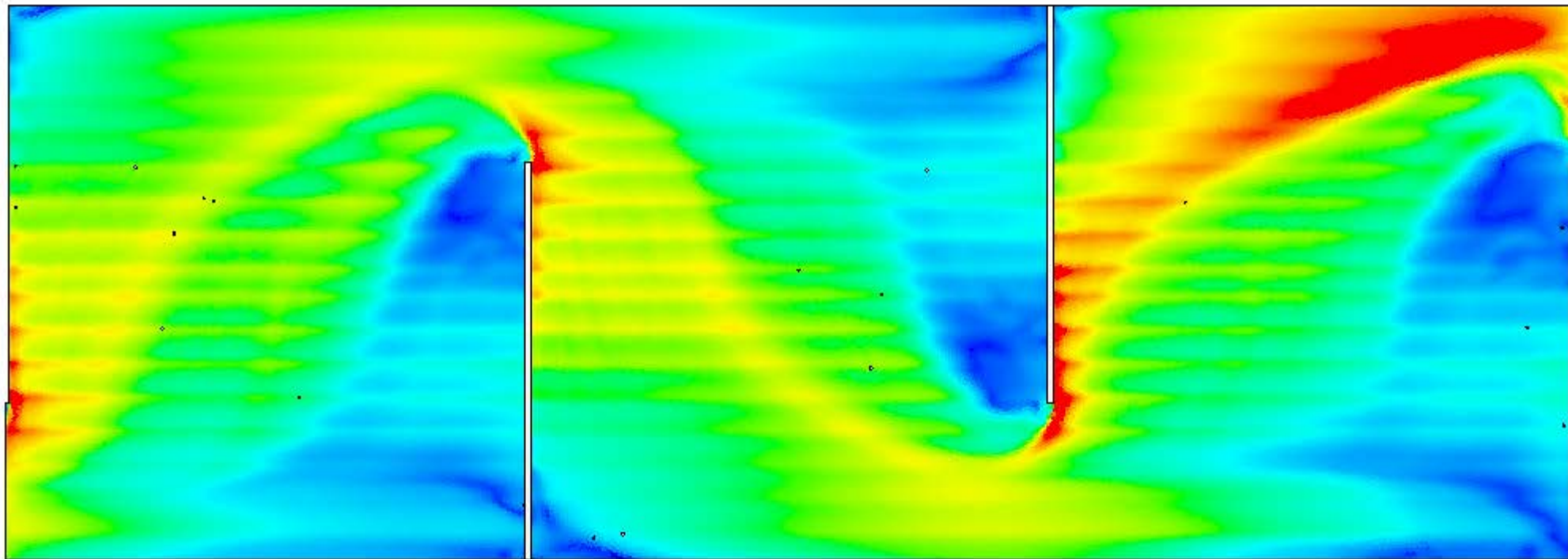

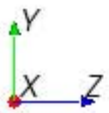
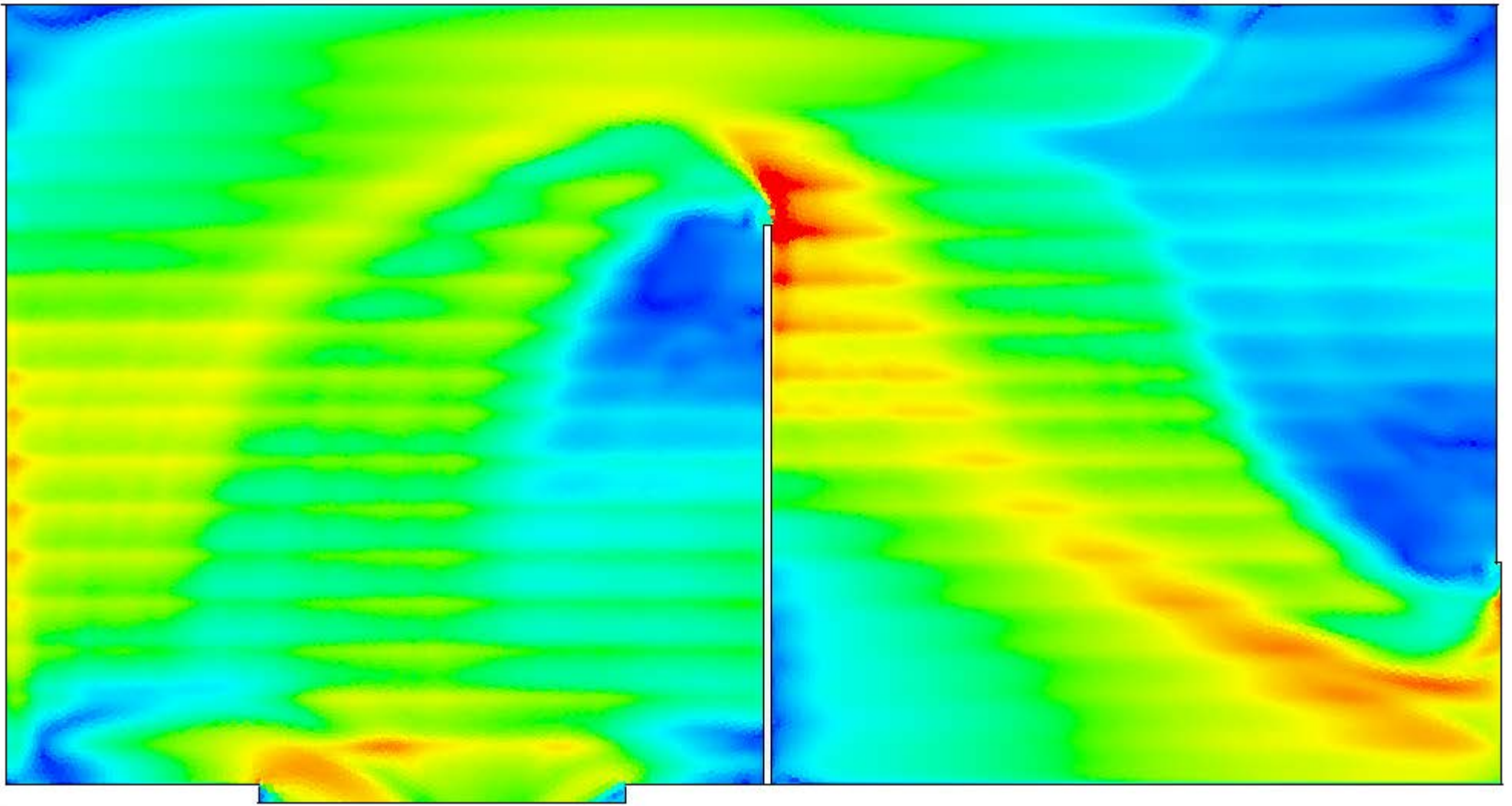

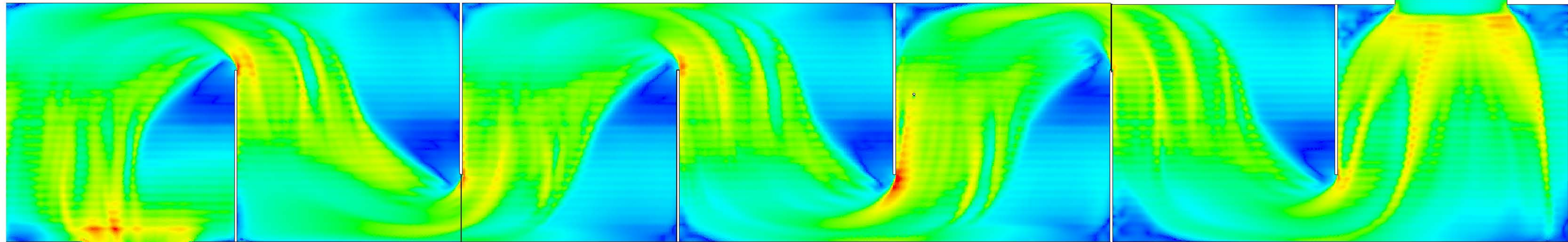

Velocity: Magnitude (m/s)

0.00000 0.60000 1.2000 1.8000 2.4000 3.0000



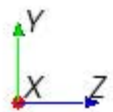
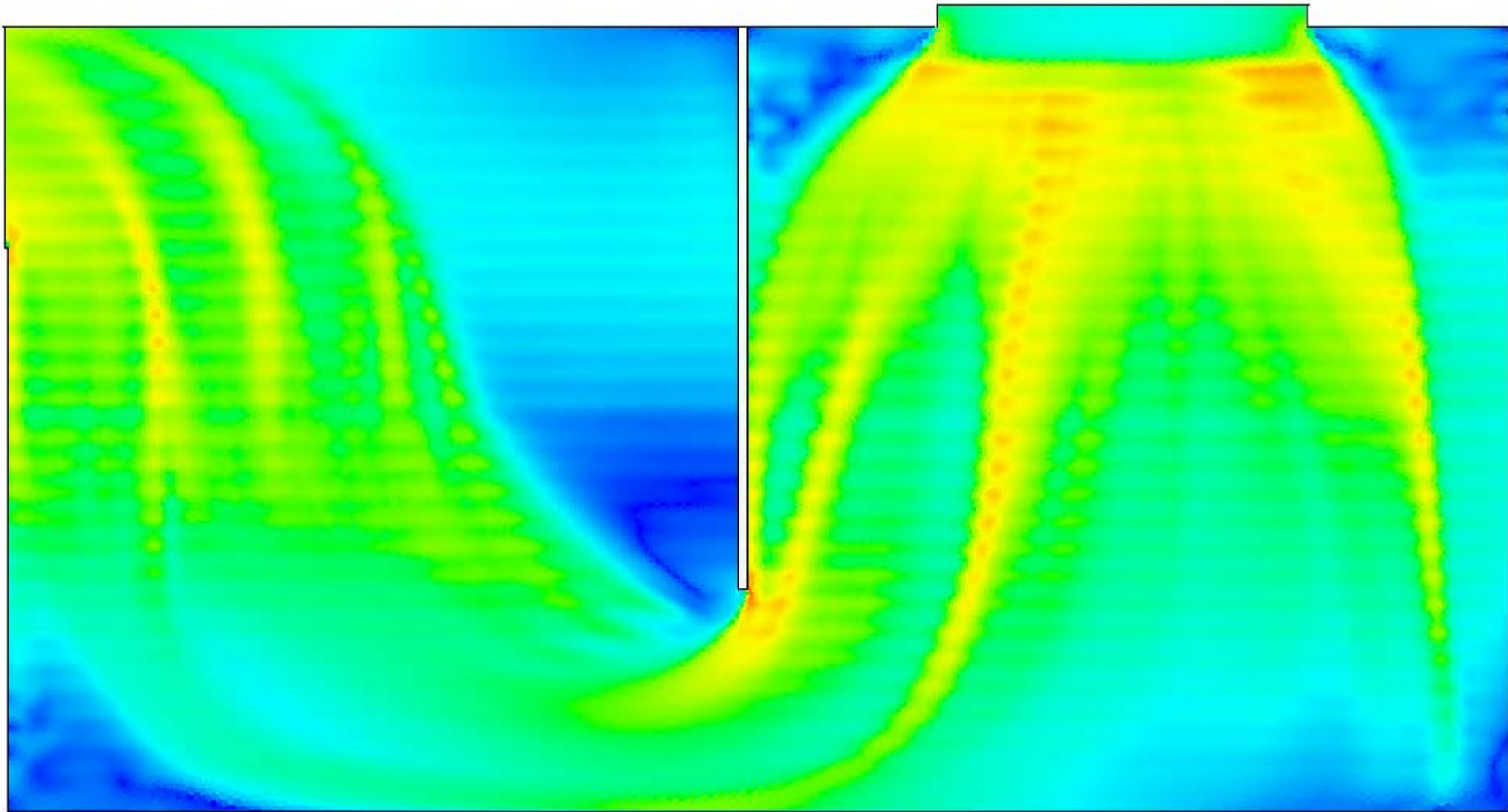

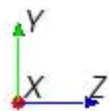
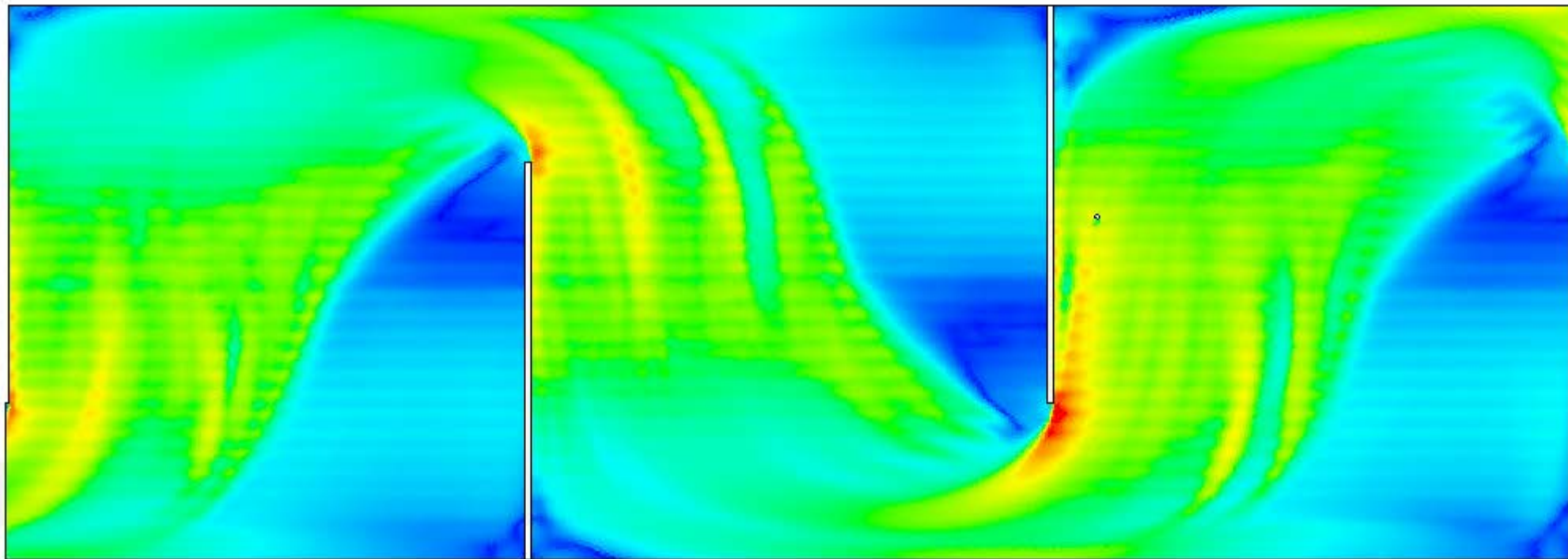

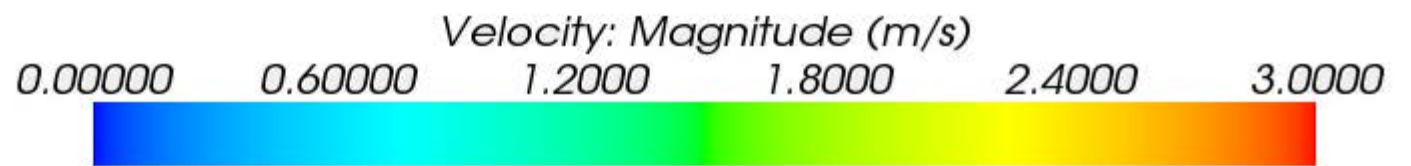
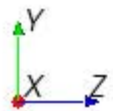
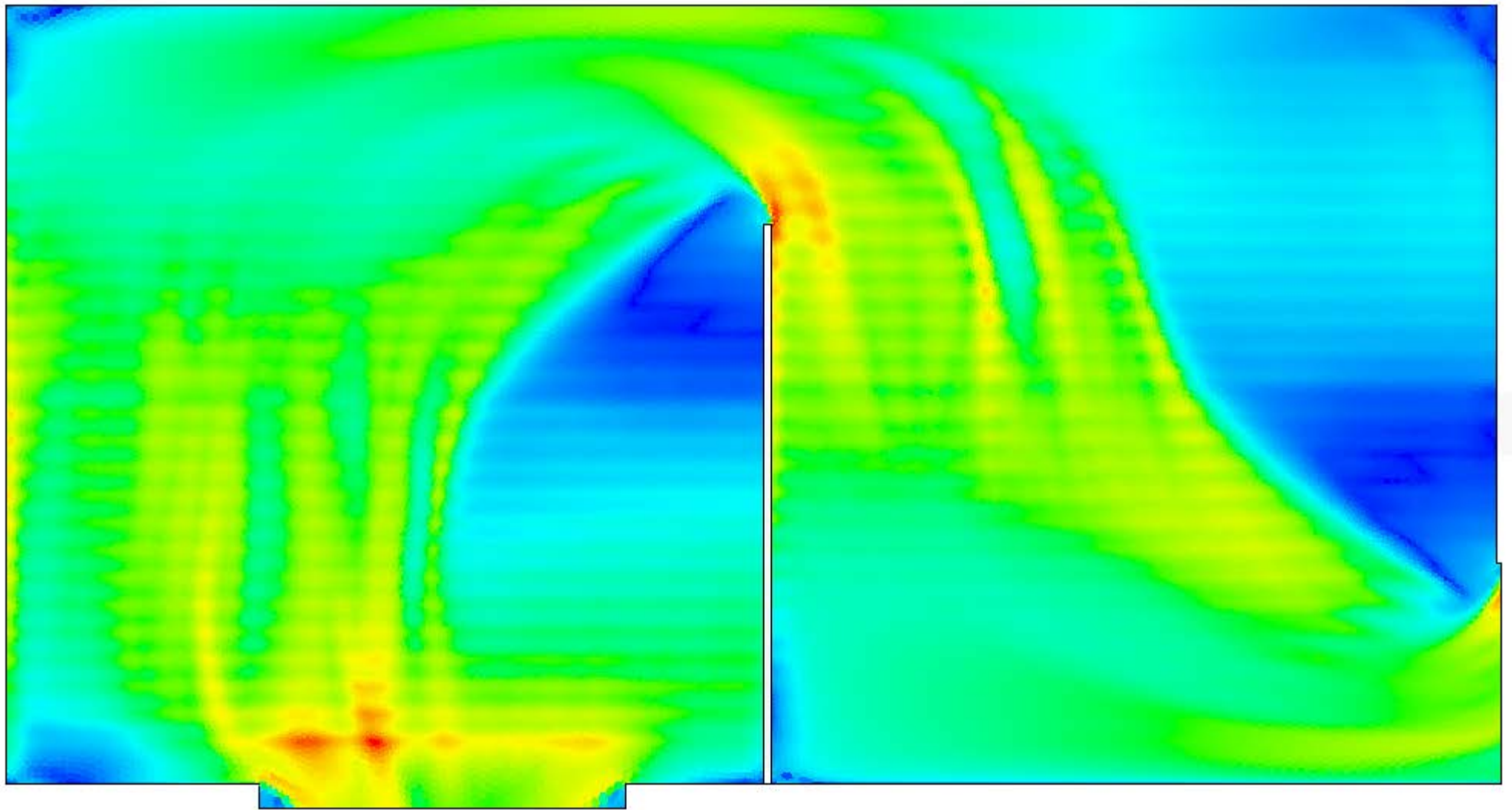

Appendix J

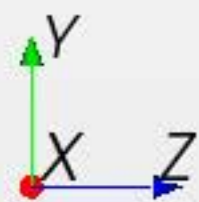

7.2580e-13

0.080000

0.16000

0.24000

0.32000

0.40000

Volume Fraction of Sand

Solution Time 0.001 (s)

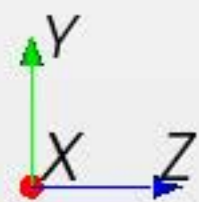
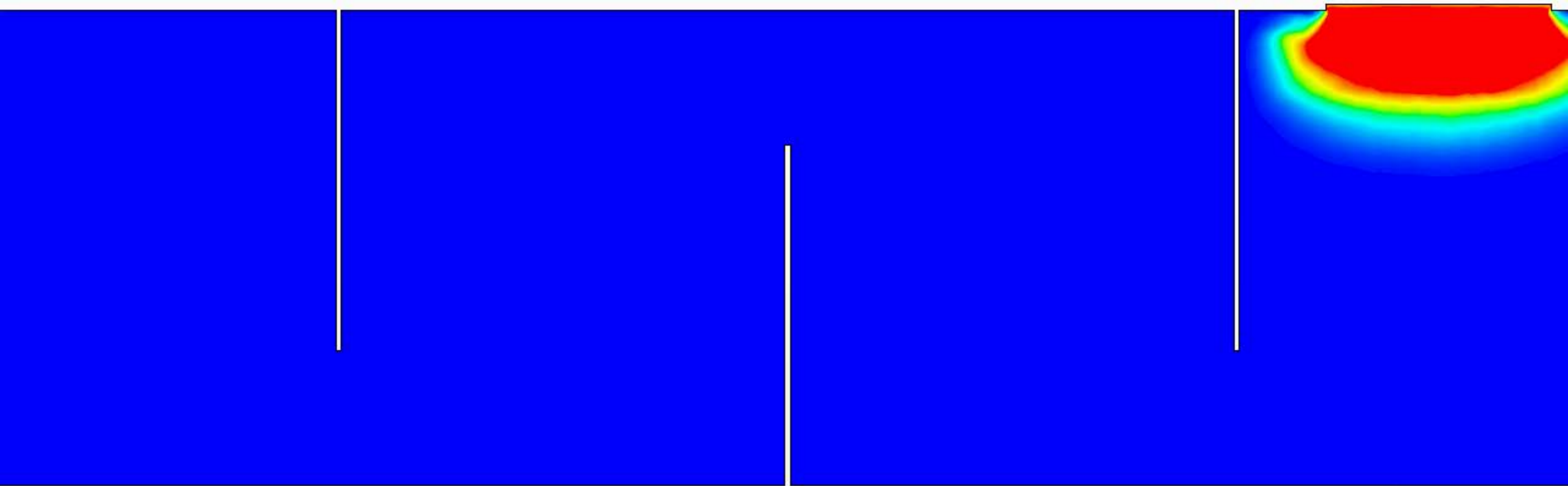

Volume Fraction of Sand

$3.3023e-15$

0.080000

0.16000

0.24000

0.32000

0.40000



Solution Time 0.101 (s)

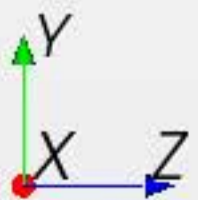
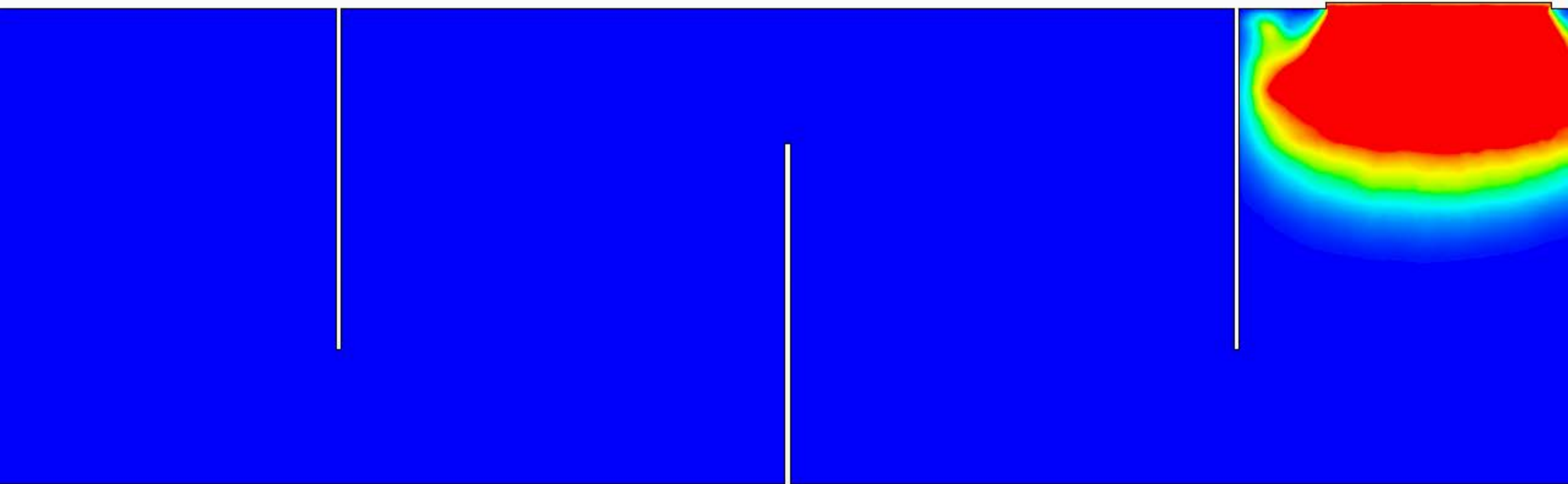

Solution Time 0.201 (s)

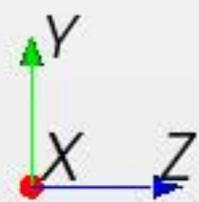
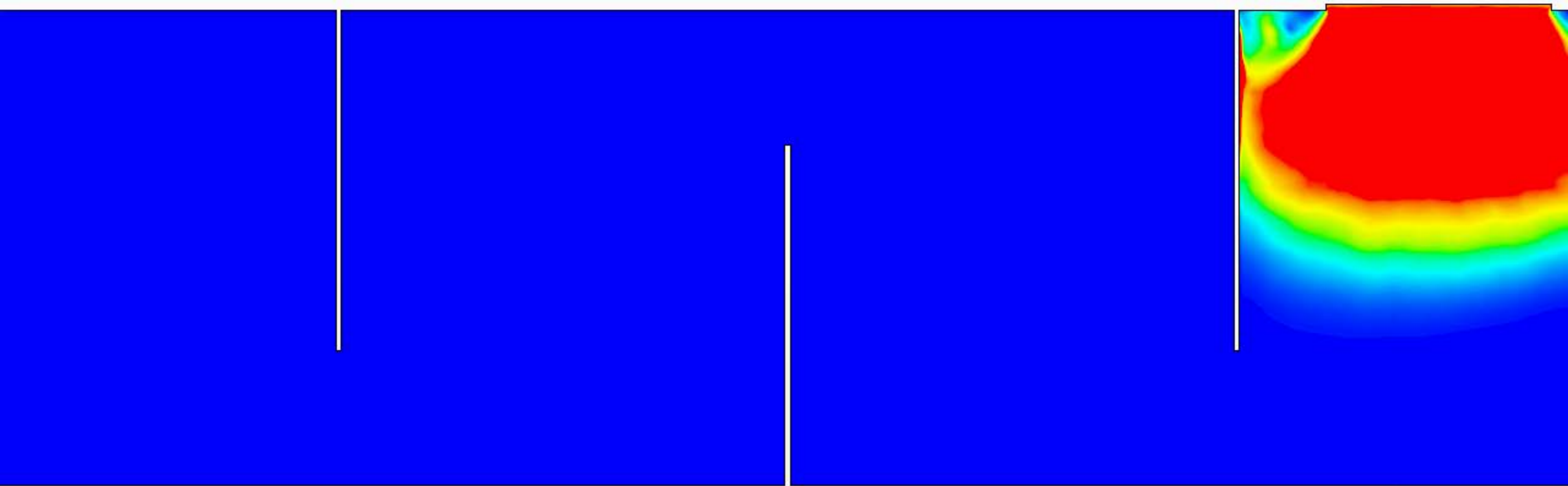

Volume Fraction of Sand

1.6424e-21

0.080000

0.16000

0.24000

0.32000

0.40000



Solution Time 0.301 (s)

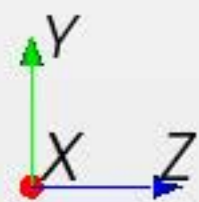
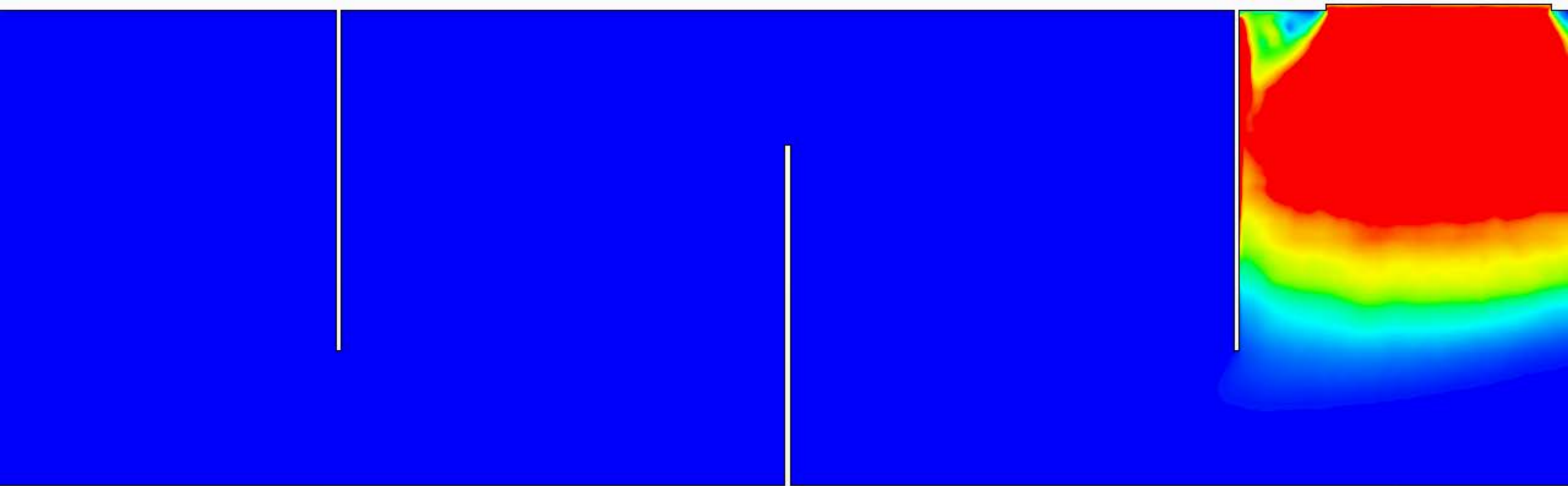

Volume Fraction of Sand

1.3780e-24

0.080000

0.16000

0.24000

0.32000

0.40000



Solution Time 0.401 (s)

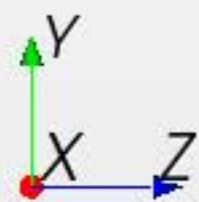
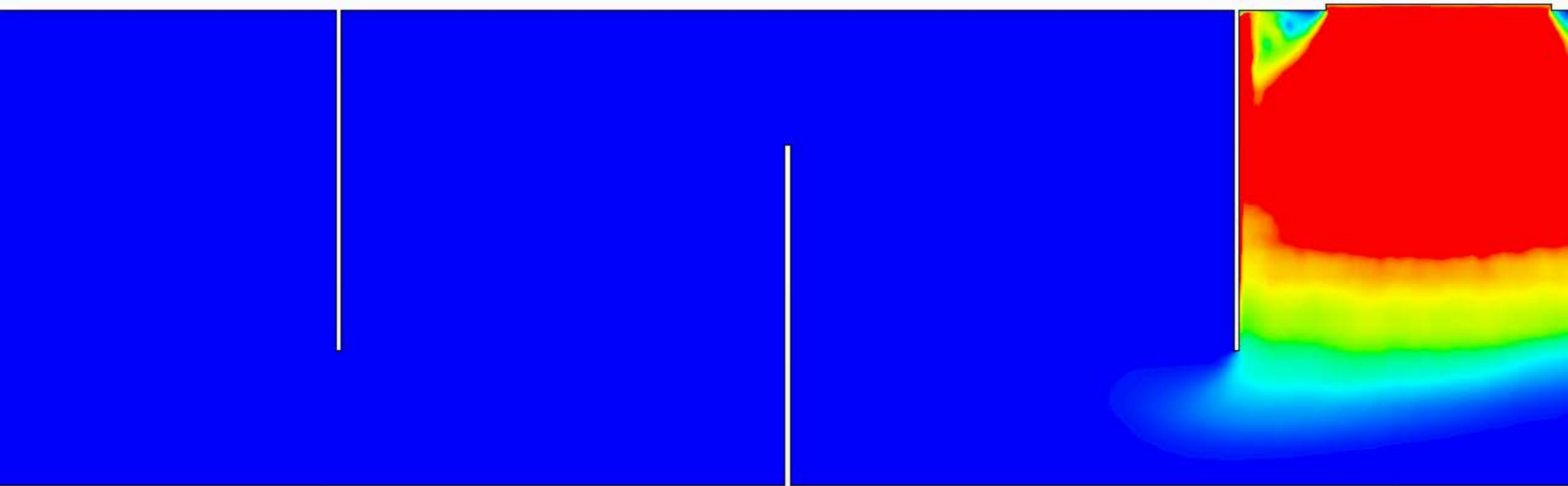

Solution Time 0.501 (s)

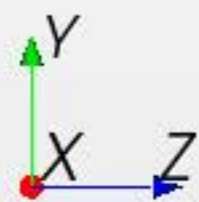
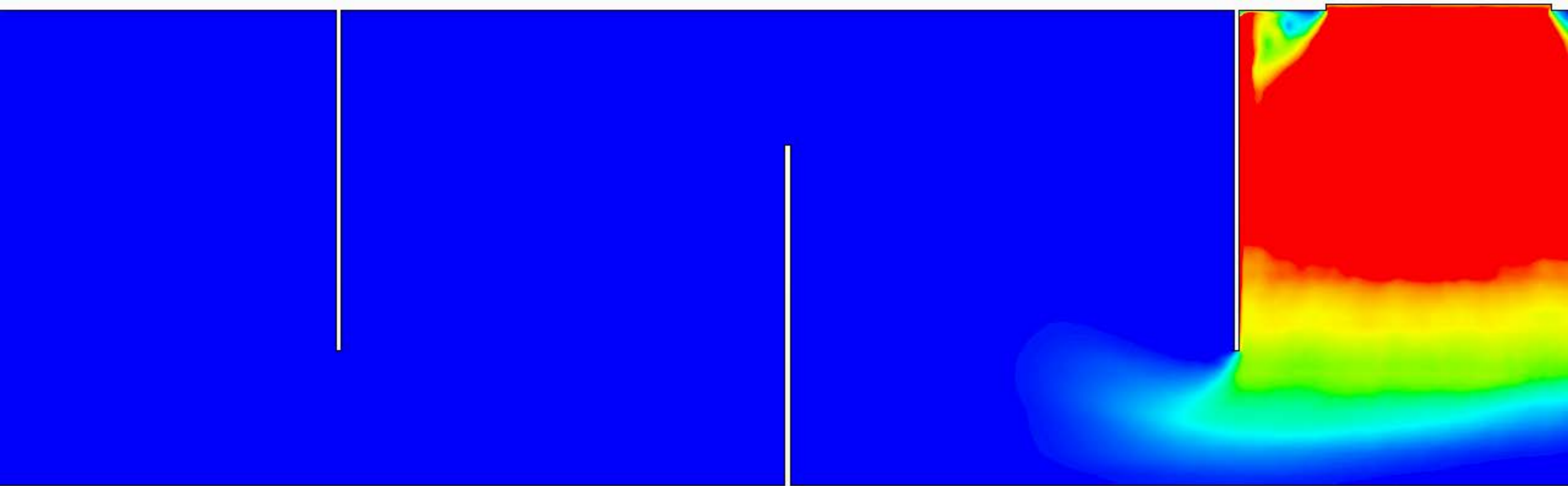

8.6344e-31

0.080000

0.16000

0.24000

0.32000

0.40000

Volume Fraction of Sand

Solution Time 0.601 (s)

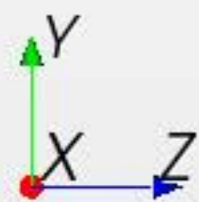
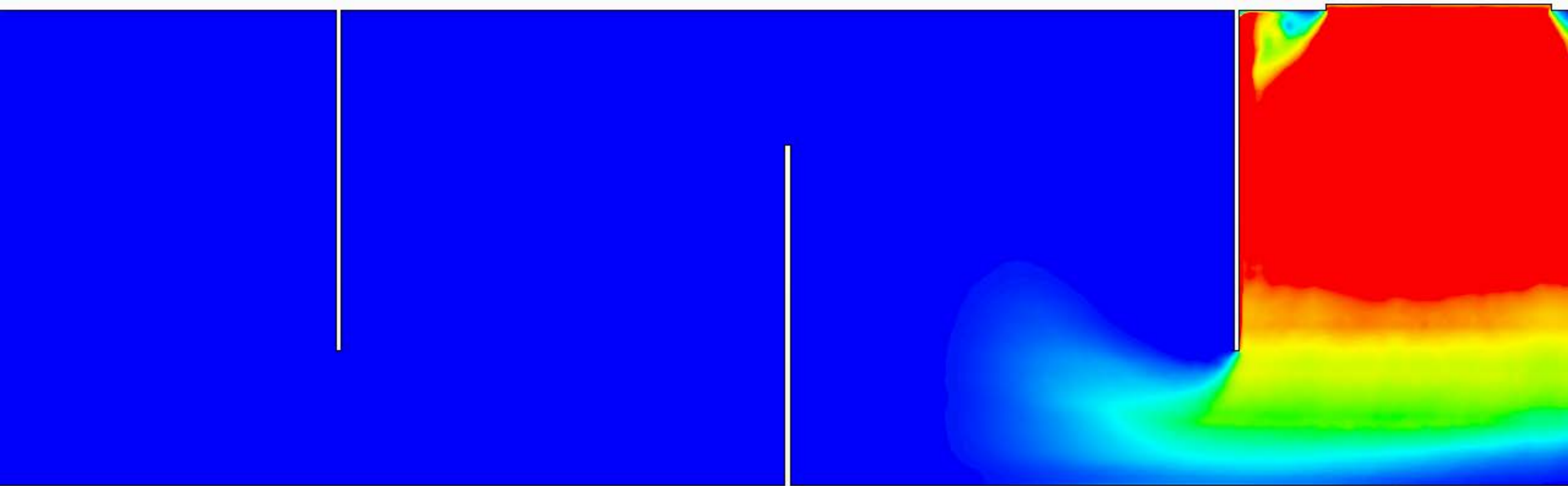

Volume Fraction of Sand

$9.8608e-32$

0.080000

0.16000

0.24000

0.32000

0.40000



Solution Time 0.701 (s)

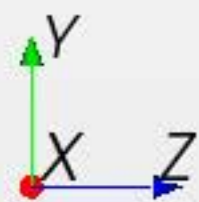
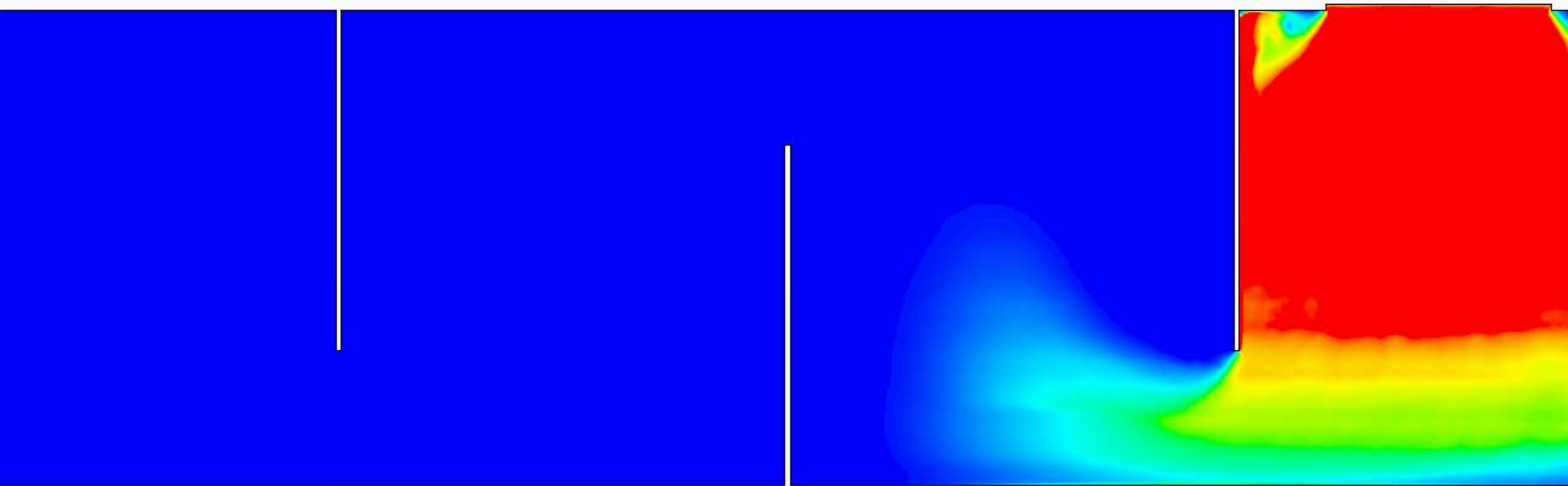

9.8608e-32

0.080000

0.16000

0.24000

0.32000

0.40000

Volume Fraction of Sand

Solution Time 0.801 (s)

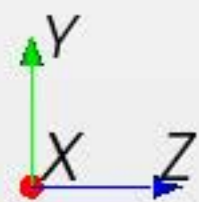
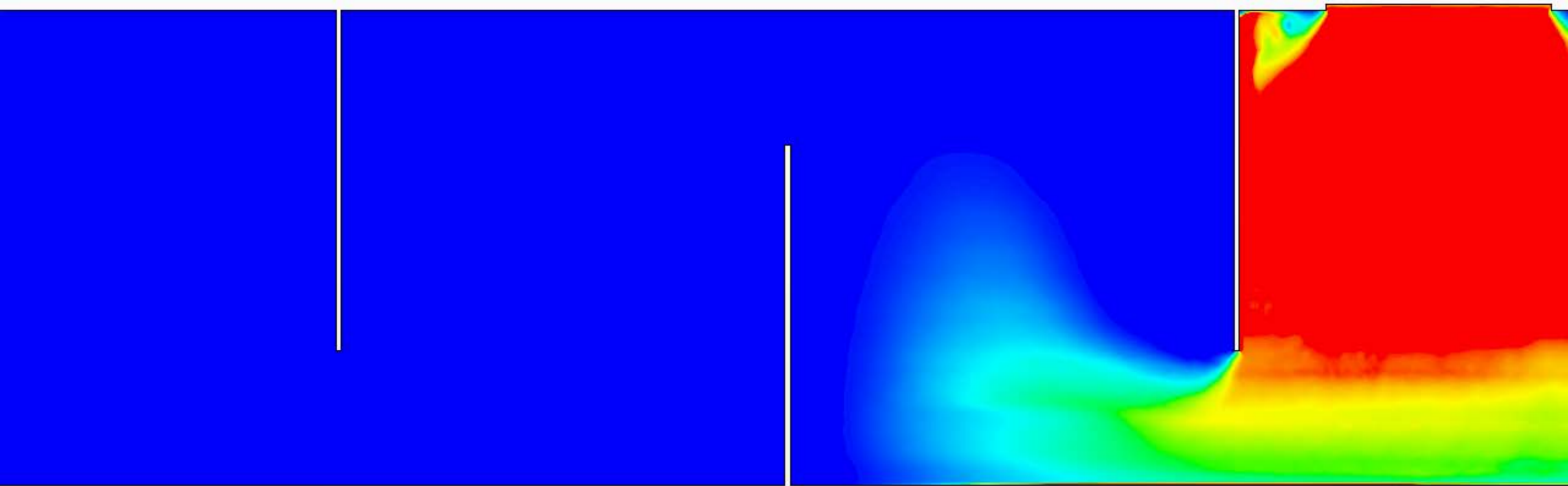

9.8608e-32

0.080000

0.16000

0.24000

0.32000

0.40000

Volume Fraction of Sand

Solution Time 0.901 (s)

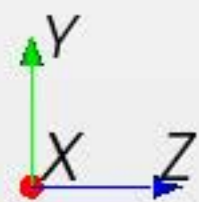
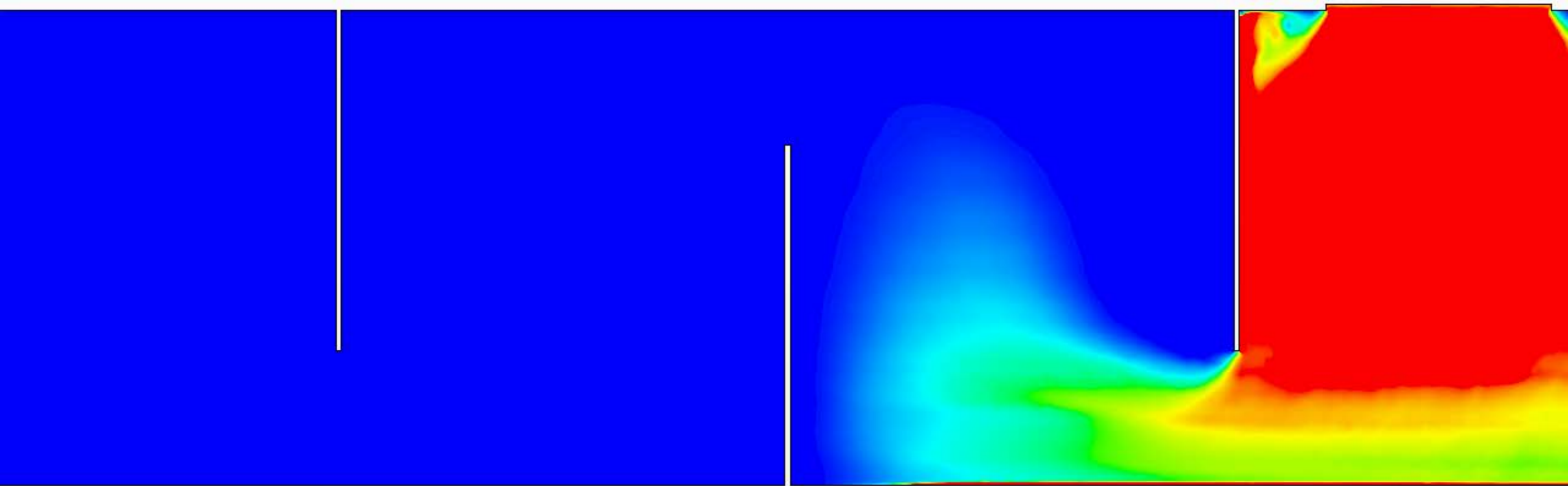

9.8608e-32

0.080000

0.16000

0.24000

0.32000

0.40000

Volume Fraction of Sand

Solution Time 1.001 (s)

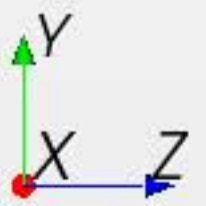
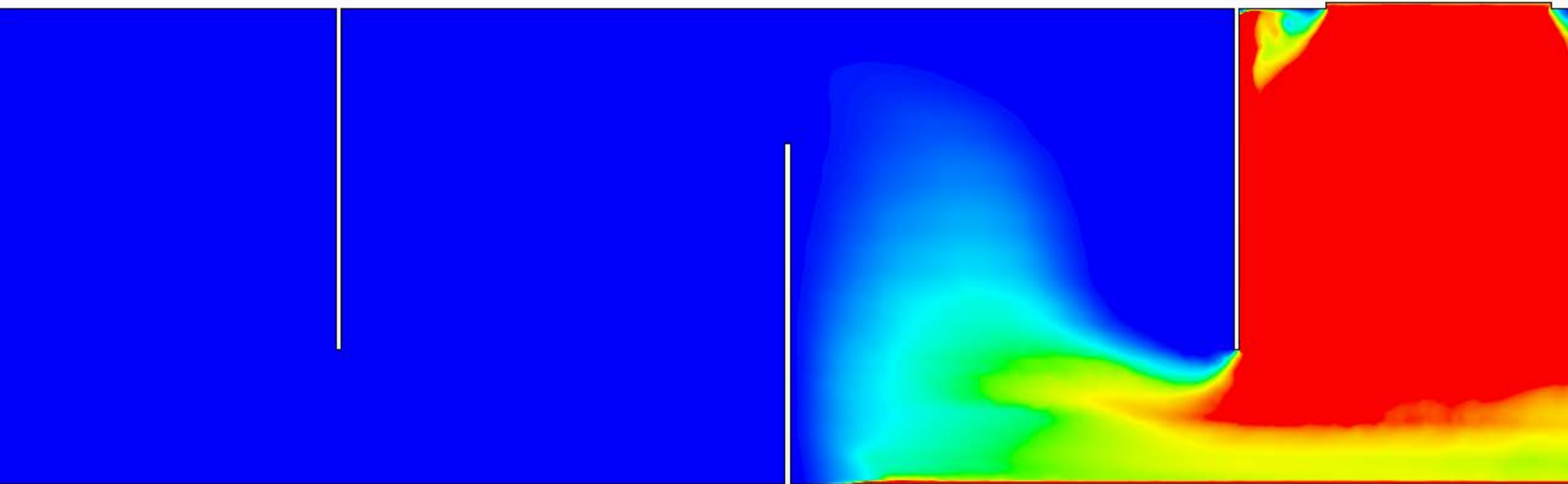

Solution Time 1.101 (s)

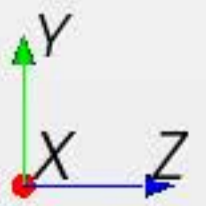
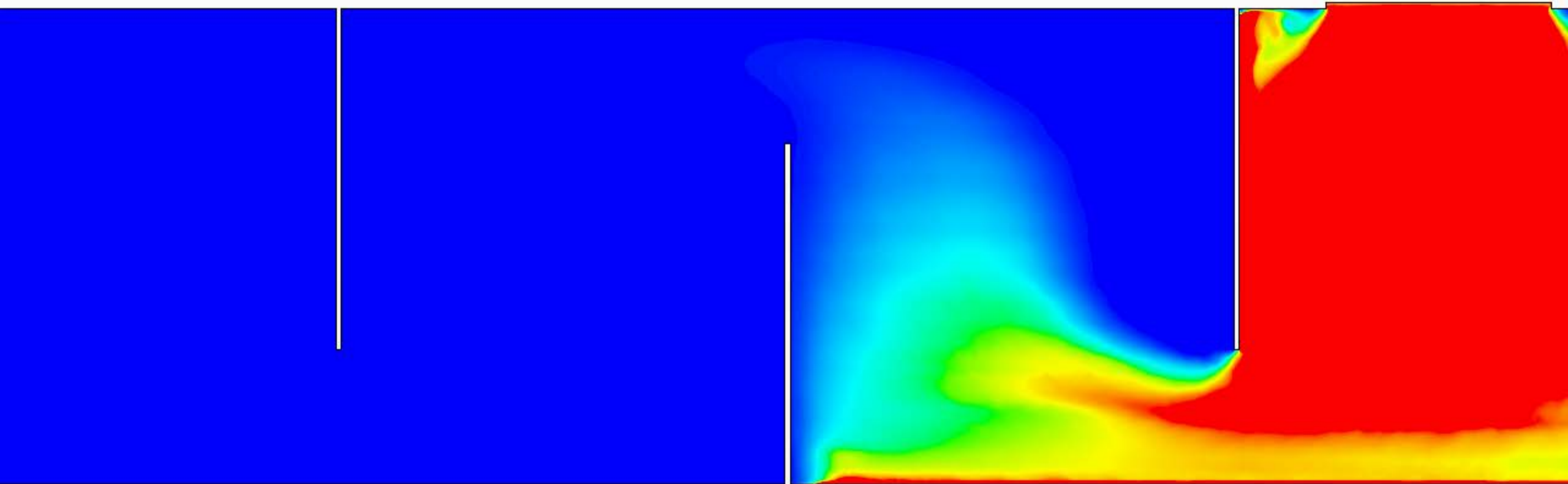

Solution Time 1.201 (s)

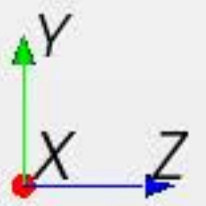
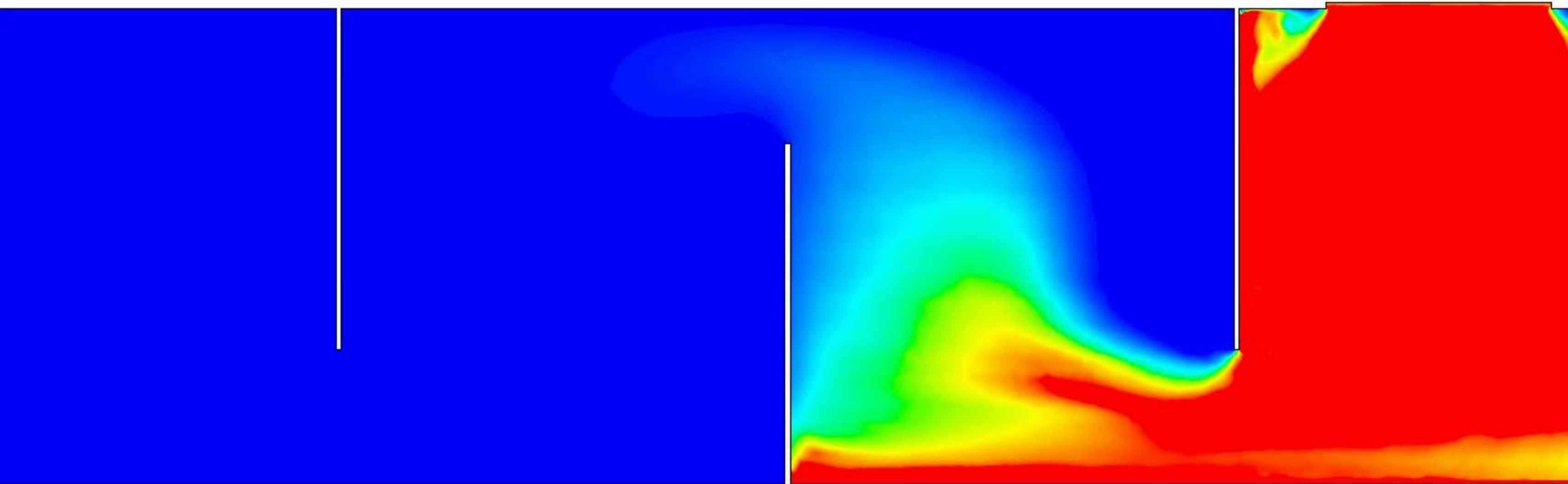

Solution Time 1.331 (s)

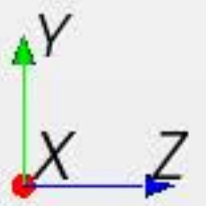
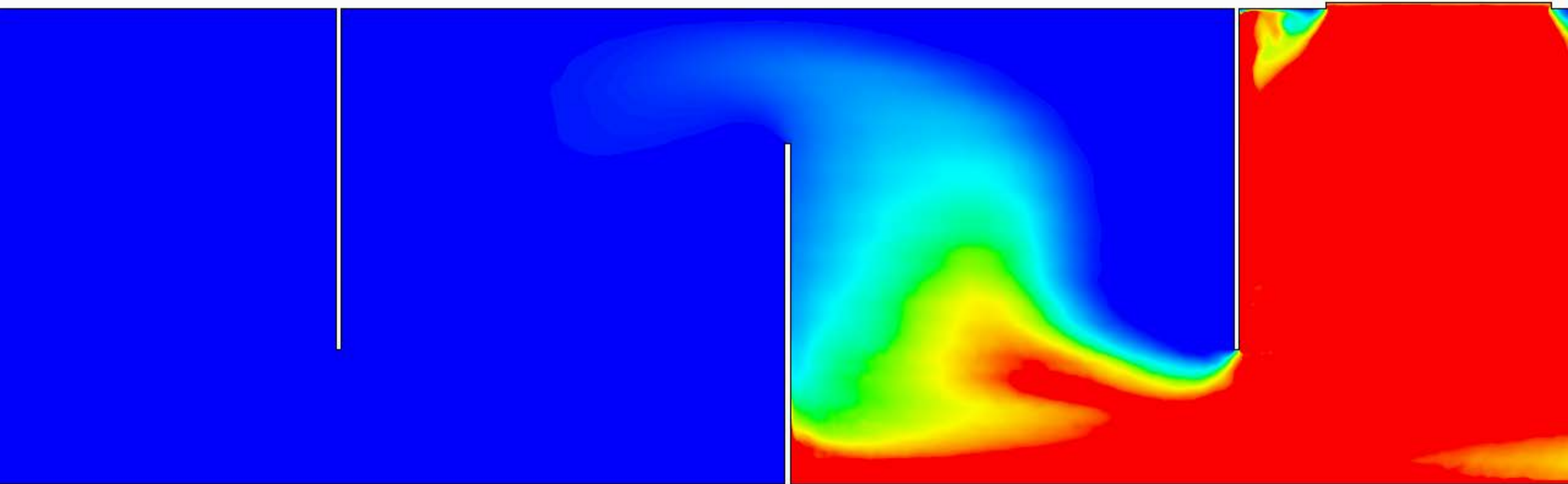

Solution Time 1.401 (s)

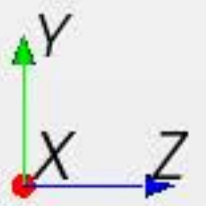
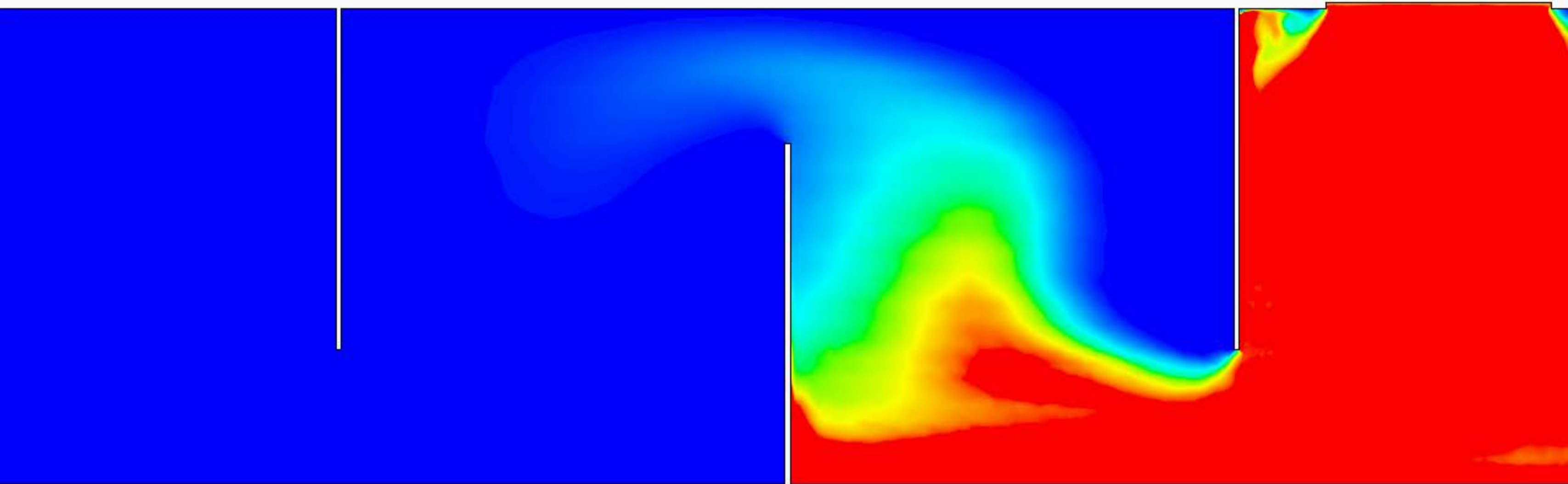

Solution Time 1.501 (s)

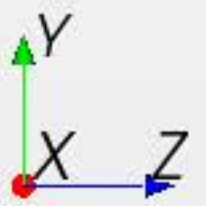
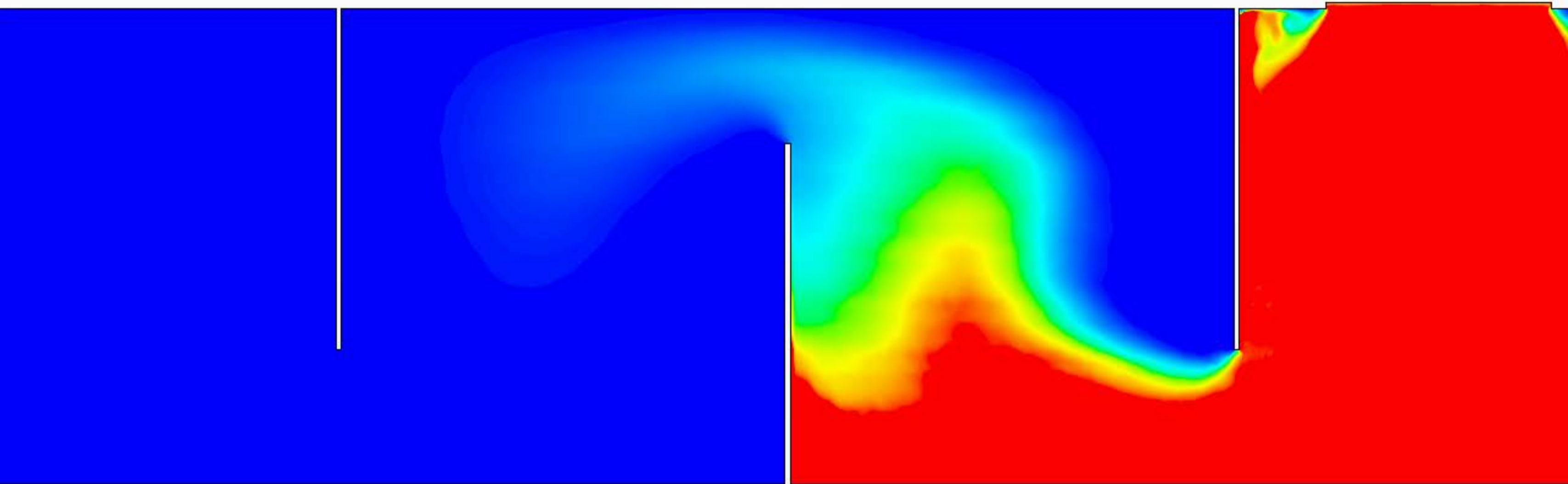

Solution Time 1.601 (s)

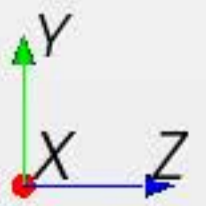
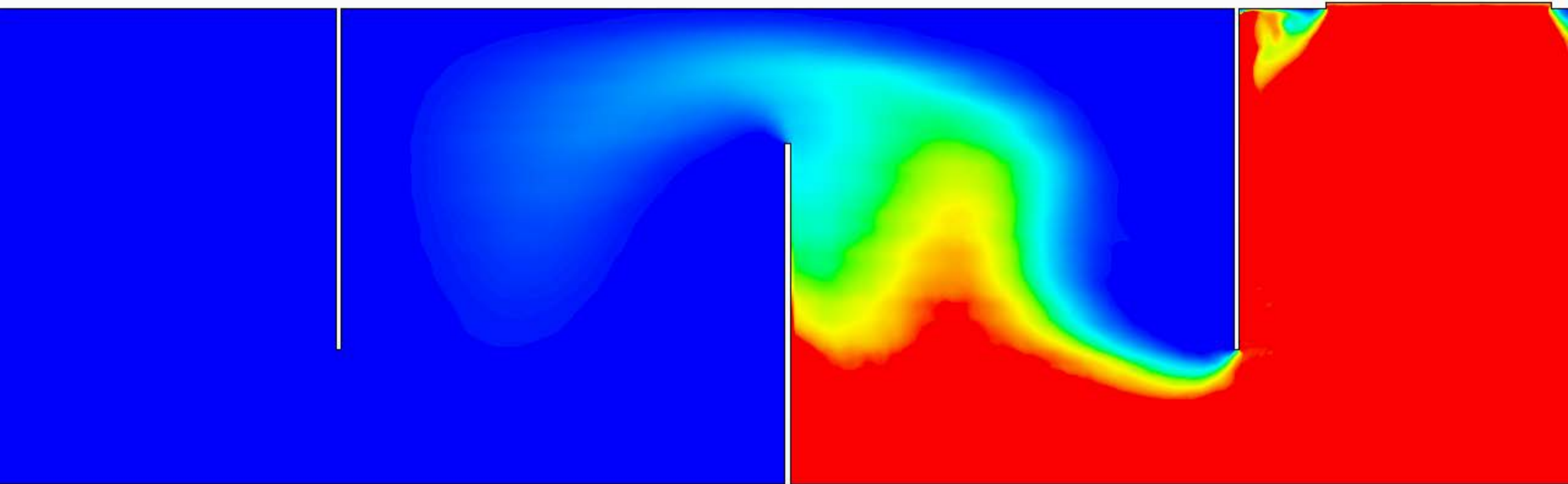

Solution Time 1.701 (s)

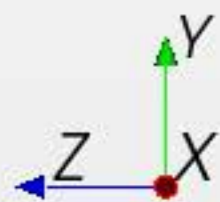
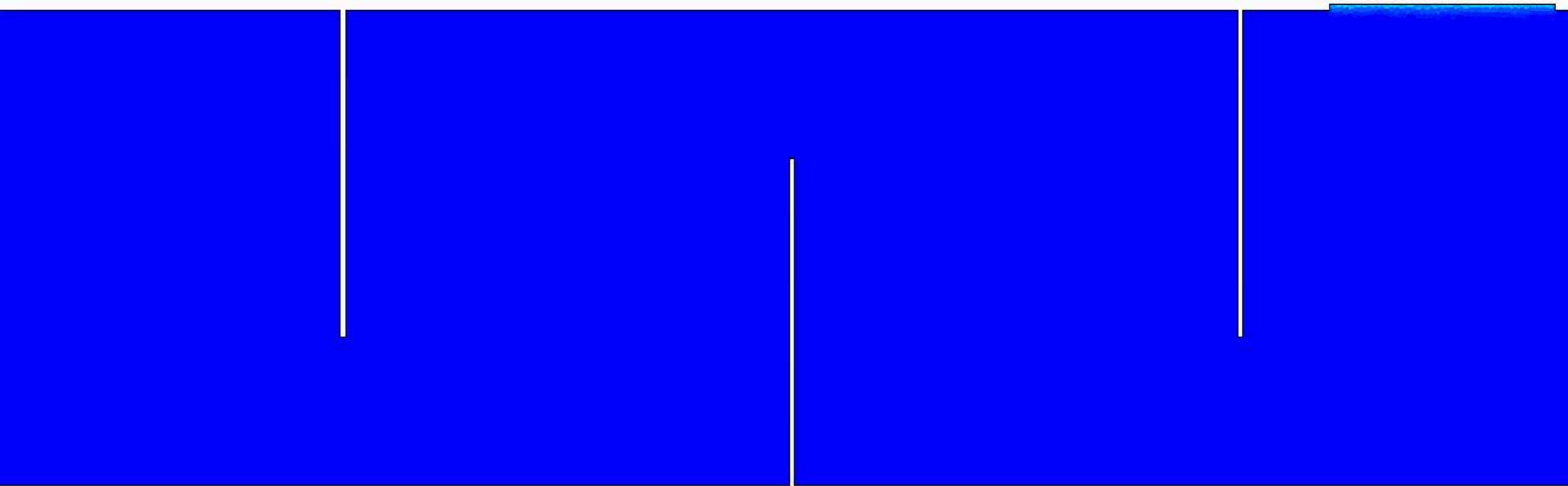

Volume Fraction of Sand

$6.7269e-13$

0.16000

0.32000

0.48000

0.64000

0.80000



Solution Time 0.001 (s)

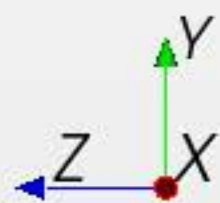
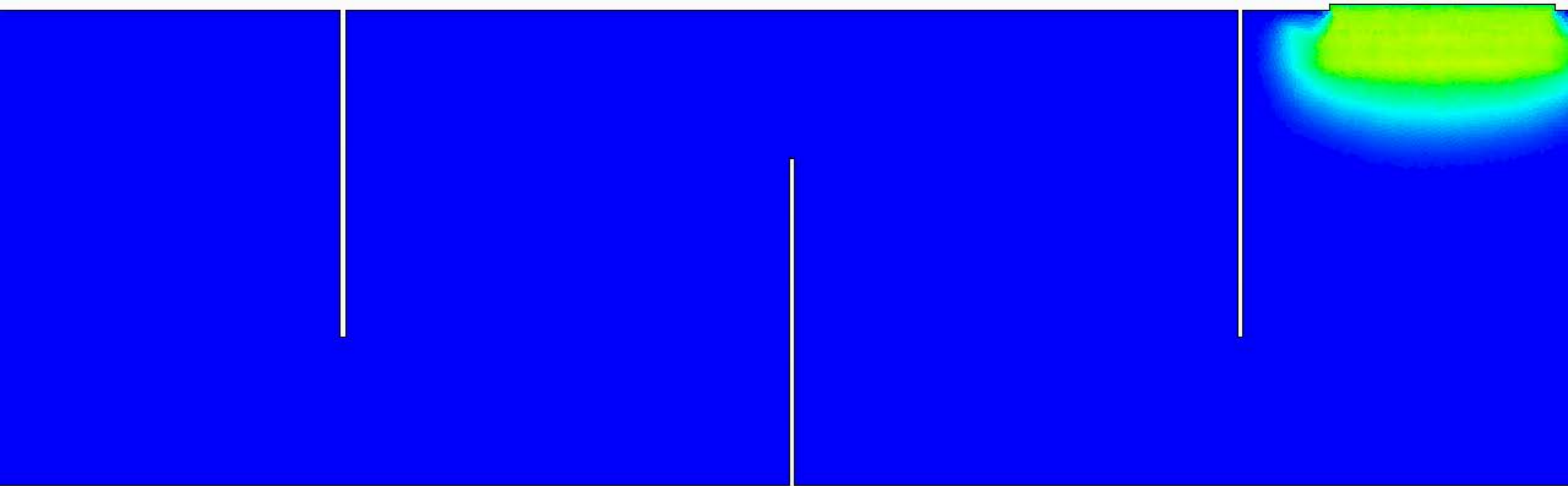

Volume Fraction of Sand

$2.3772e-15$

0.16000

0.32000

0.48000

0.64000

0.80000



Solution Time 0.101 (s)

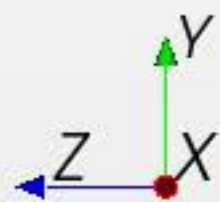
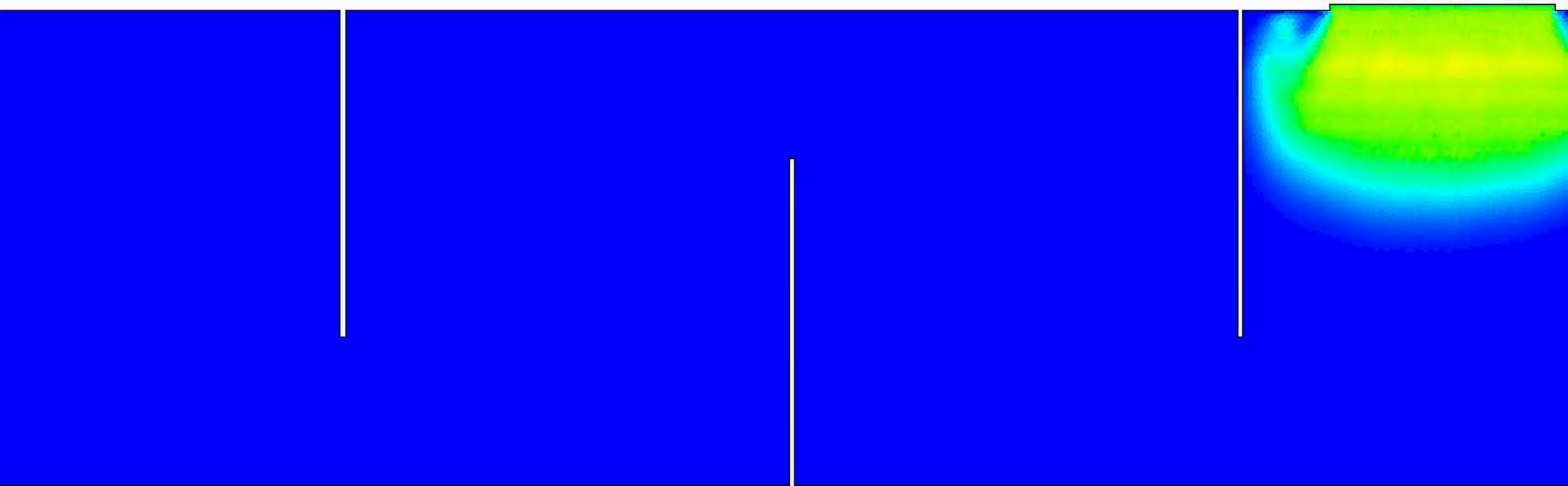

Volume Fraction of Sand

$1.3362e-18$

0.16000

0.32000

0.48000

0.64000

0.80000



Solution Time 0.201 (s)

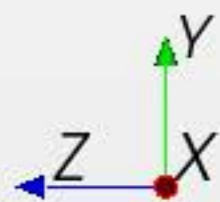
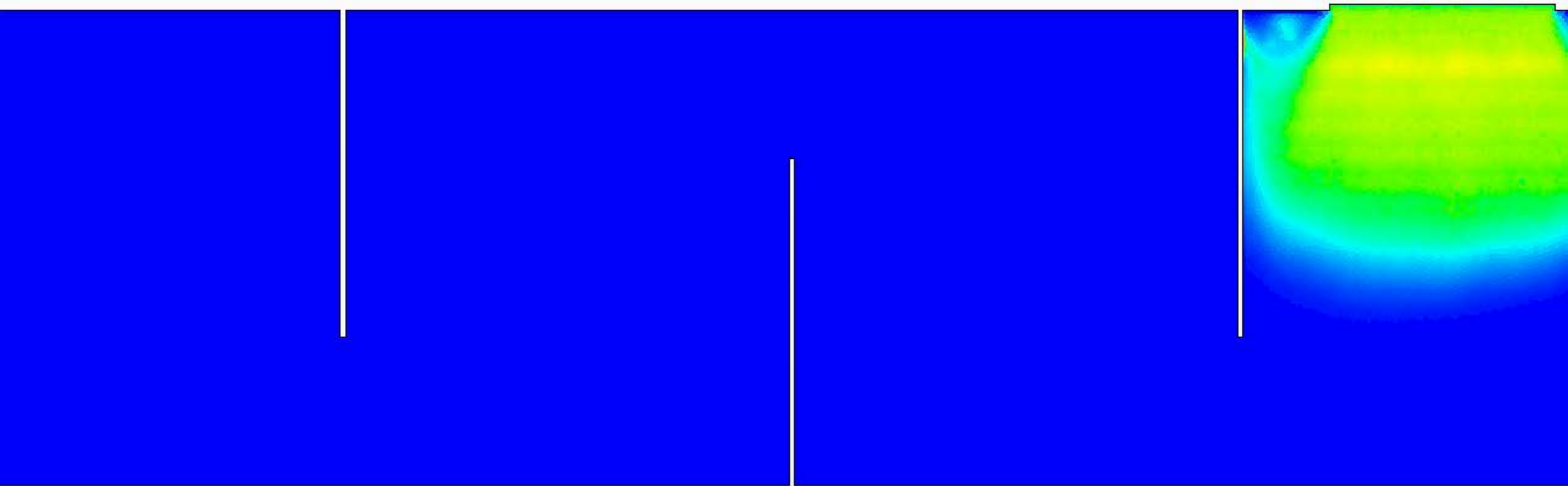

Volume Fraction of Sand

$8.1857e-22$

0.16000

0.32000

0.48000

0.64000

0.80000



Solution Time 0.301 (s)

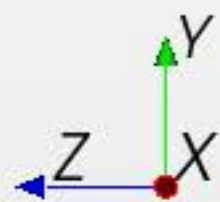
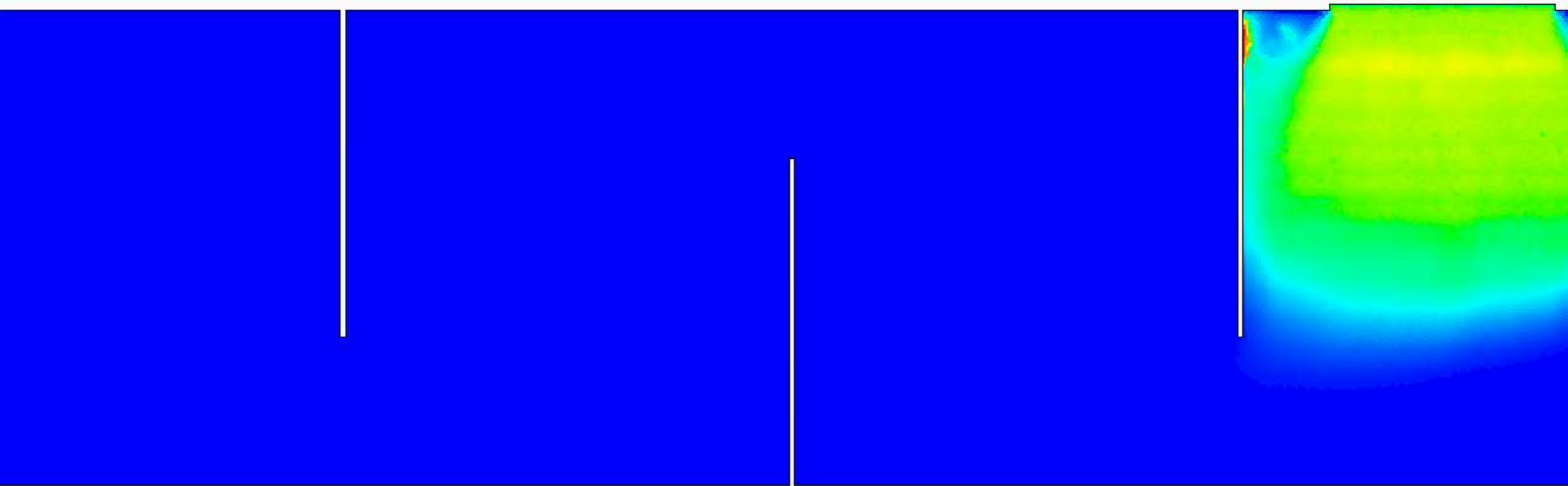

Volume Fraction of Sand

$3.4265e-25$

0.16000

0.32000

0.48000

0.64000

0.80000



Solution Time 0.401 (s)

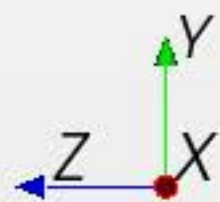
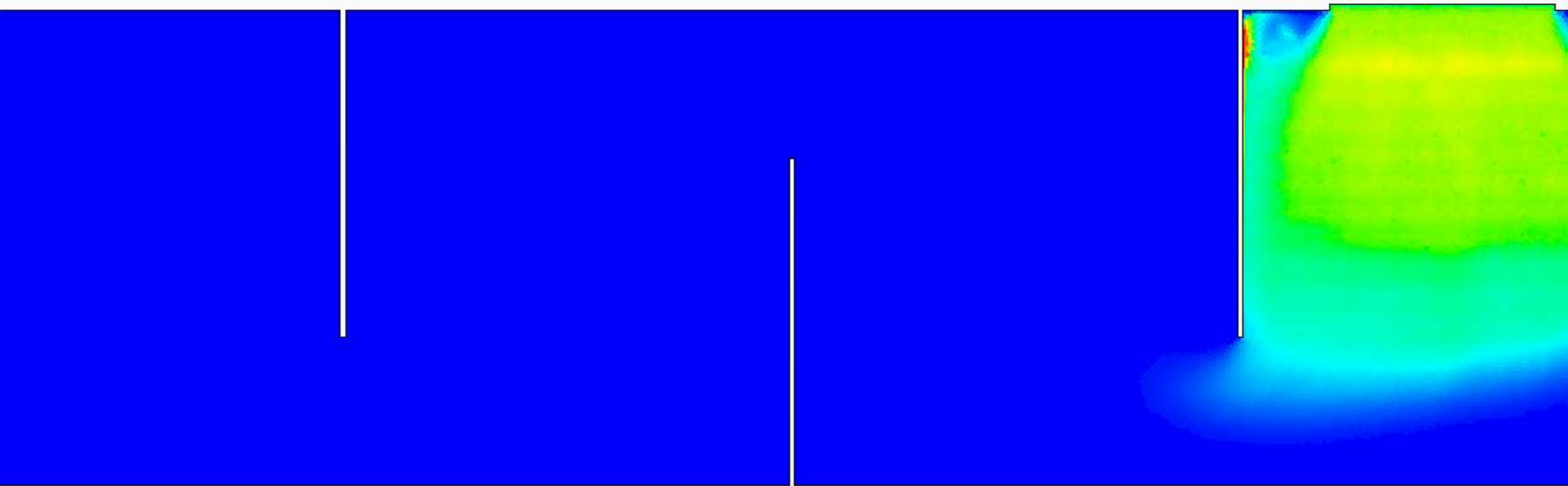

Volume Fraction of Sand

$6.3130e-29$

0.16000

0.32000

0.48000

0.64000

0.80000



Solution Time 0.511 (s)

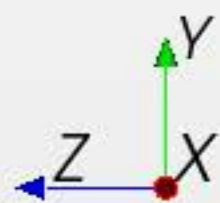
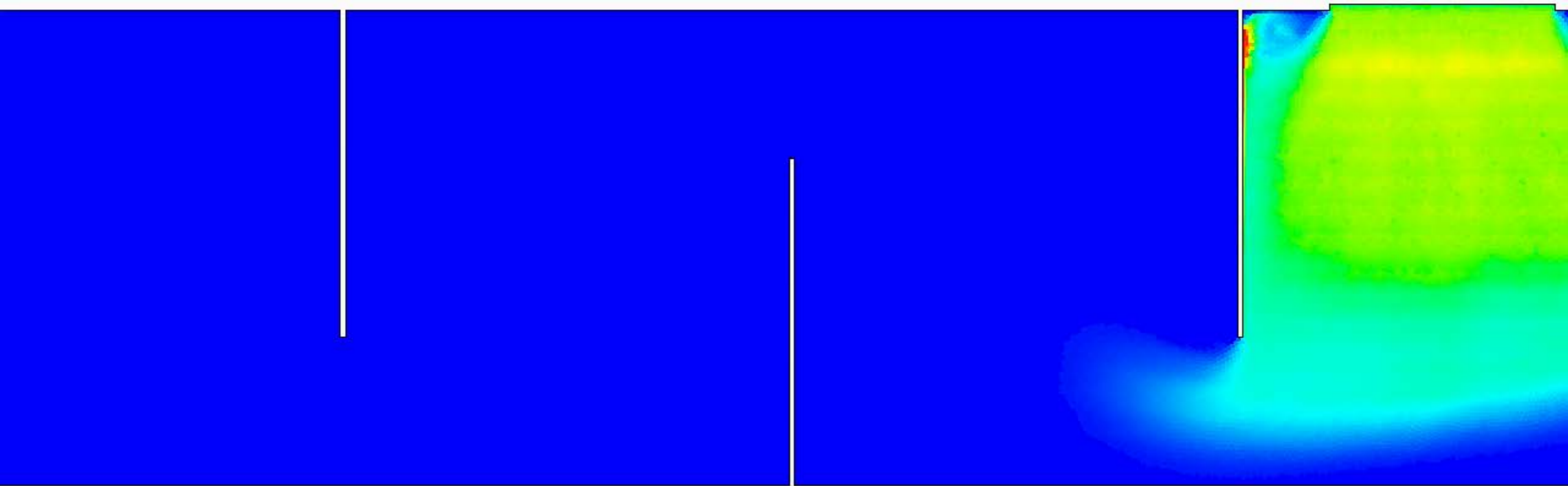

Volume Fraction of Sand

$9.8608e-32$

0.16000

0.32000

0.48000

0.64000

0.80000



Solution Time 0.611 (s)

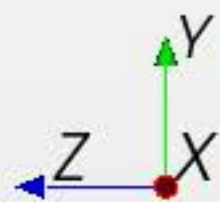
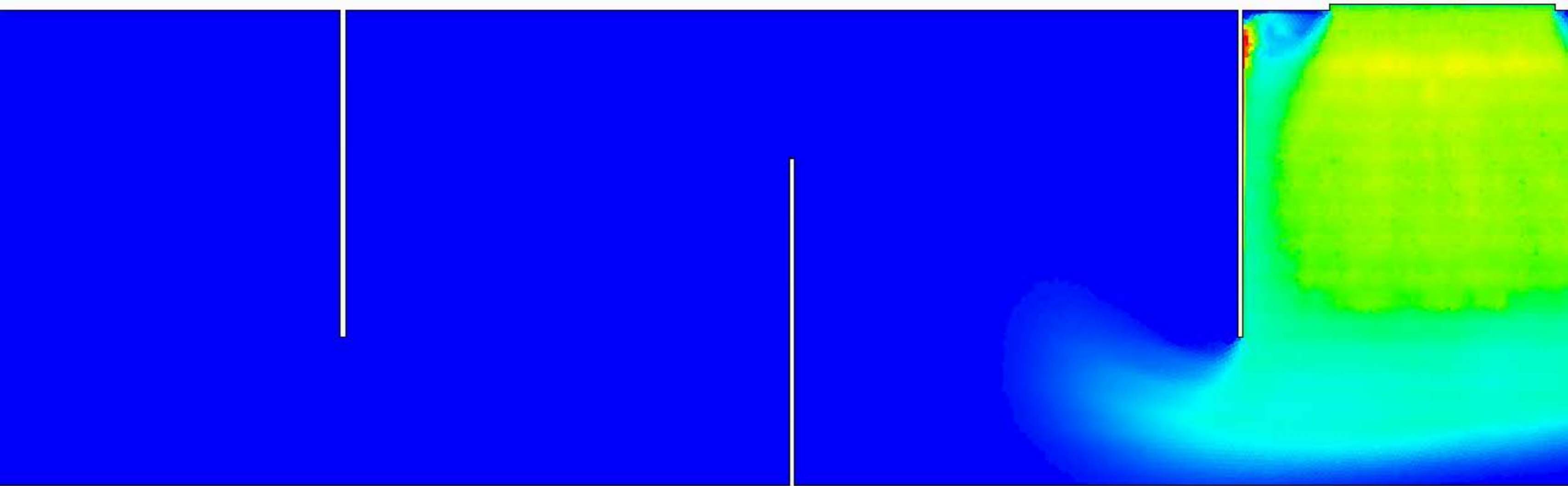

Volume Fraction of Sand

$9.8608e-32$

0.16000

0.32000

0.48000

0.64000

0.80000

Solution Time 0.701 (s)

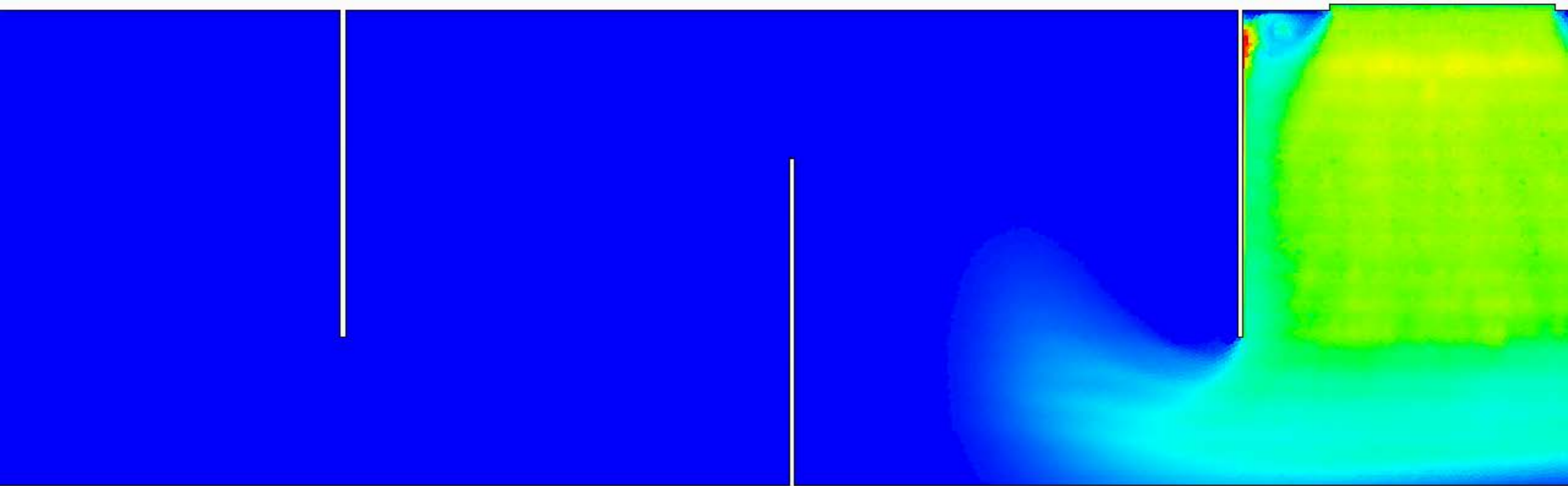

Volume Fraction of Sand

$9.8608e-32$

0.16000

0.32000

0.48000

0.64000

0.80000



Solution Time 0.801 (s)

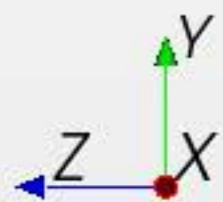
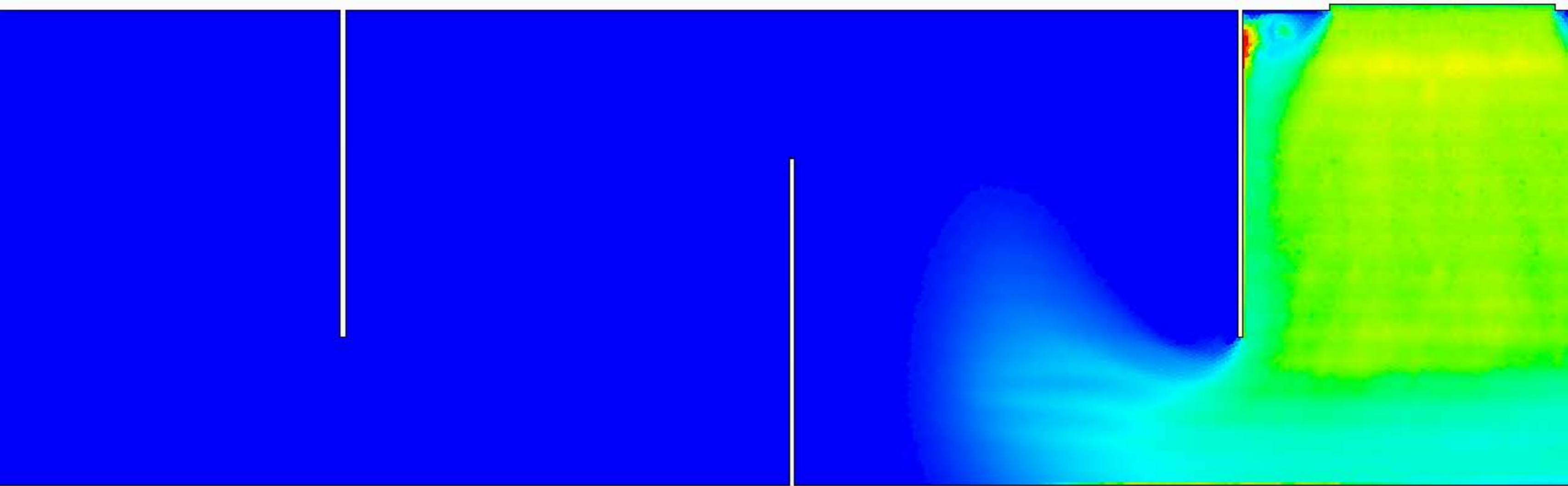

Solution Time 0.901 (s)

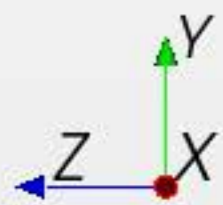
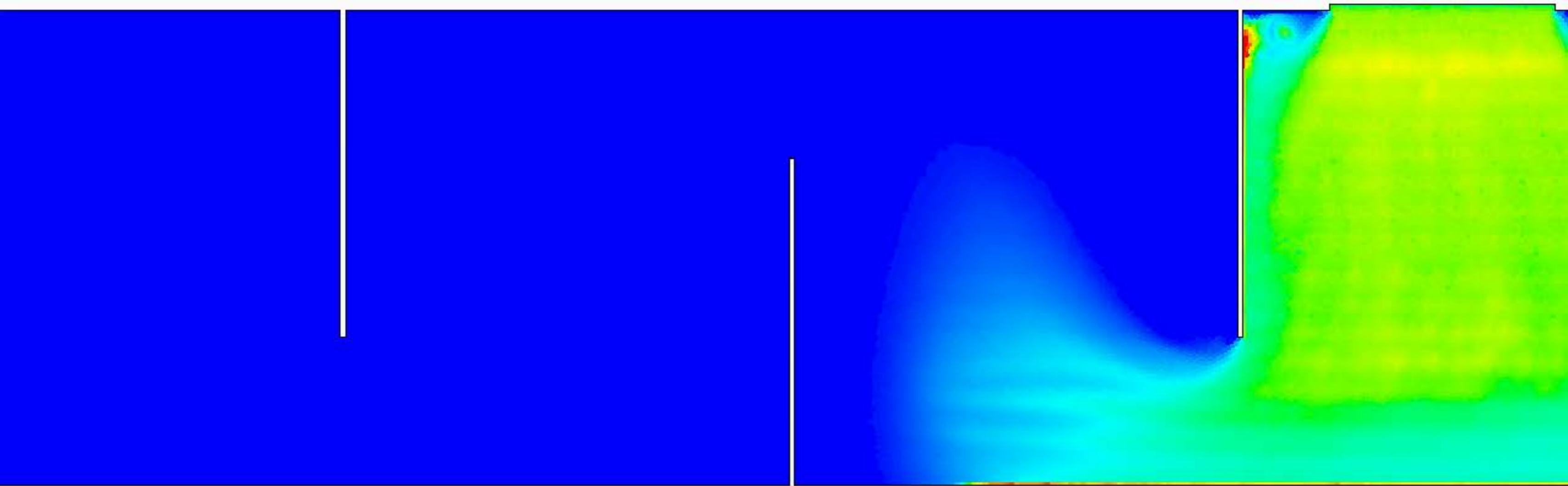

Solution Time 1.001 (s)

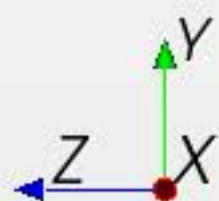
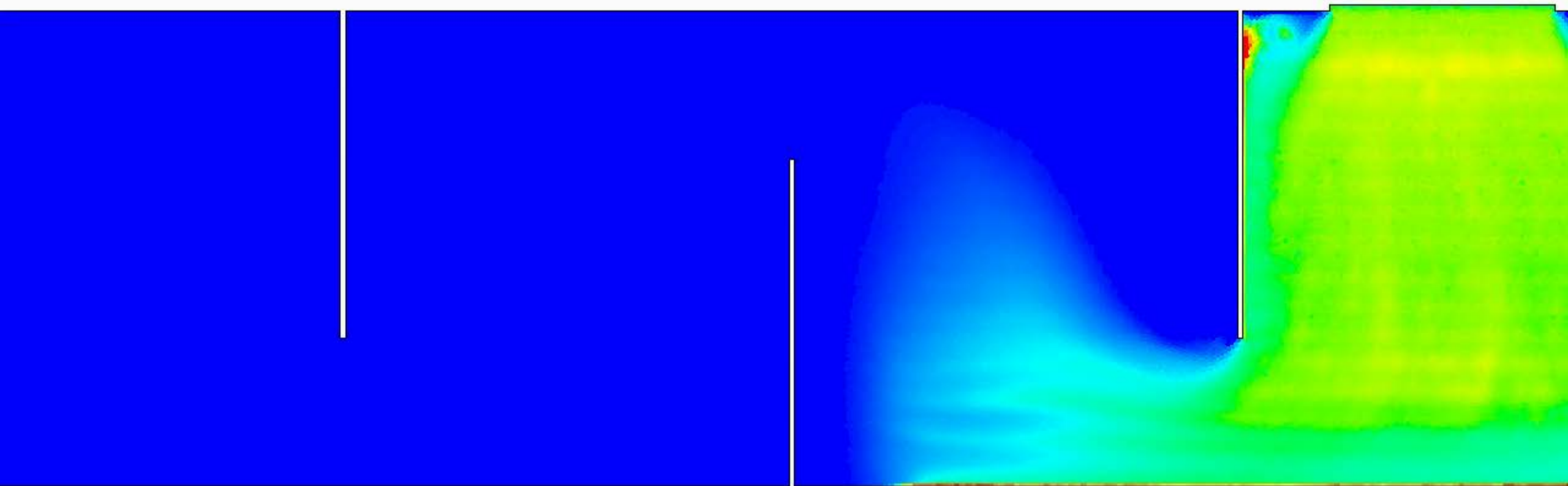

Solution Time 1.101 (s)

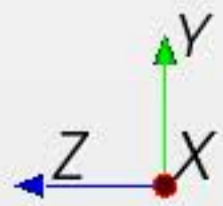
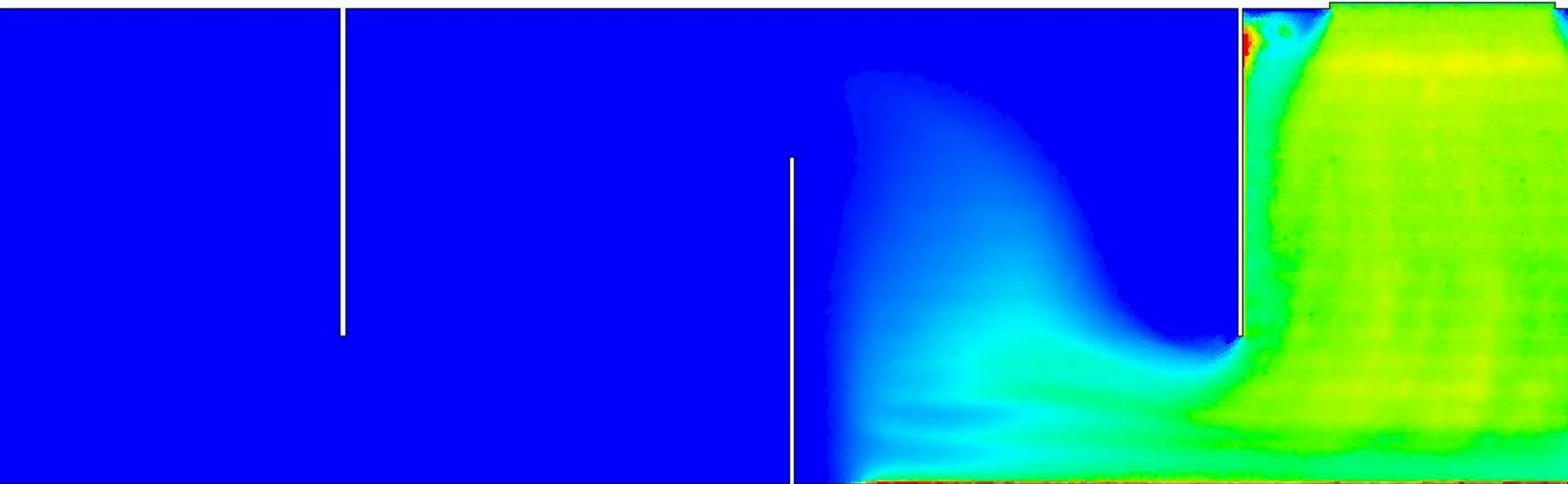

Solution Time 1.201 (s)

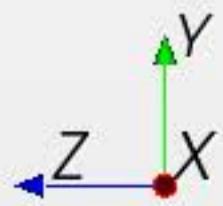
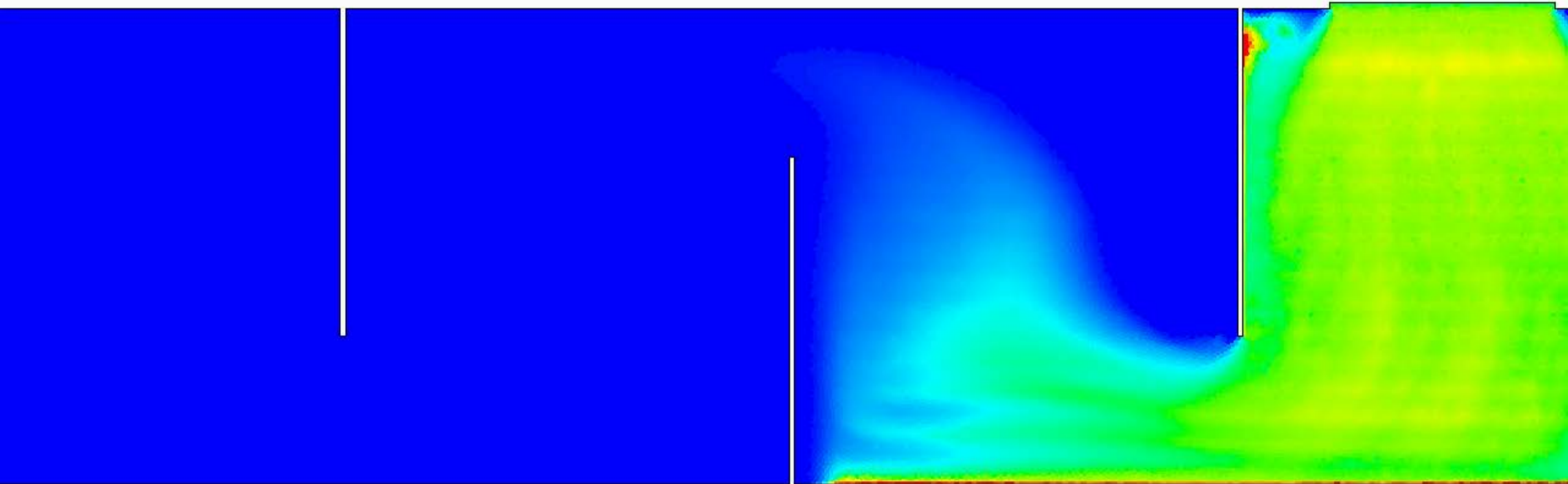

Solution Time 1.301 (s)

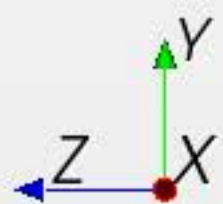
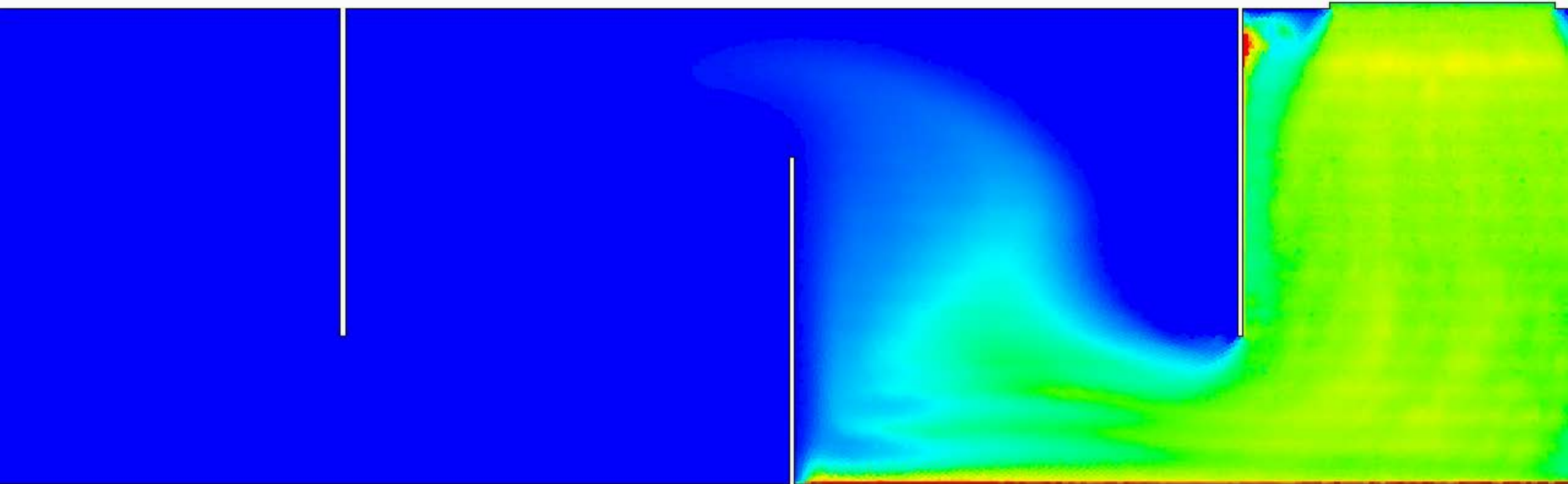

Solution Time 1.401 (s)

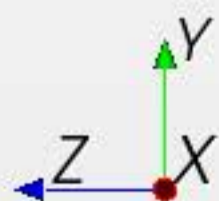
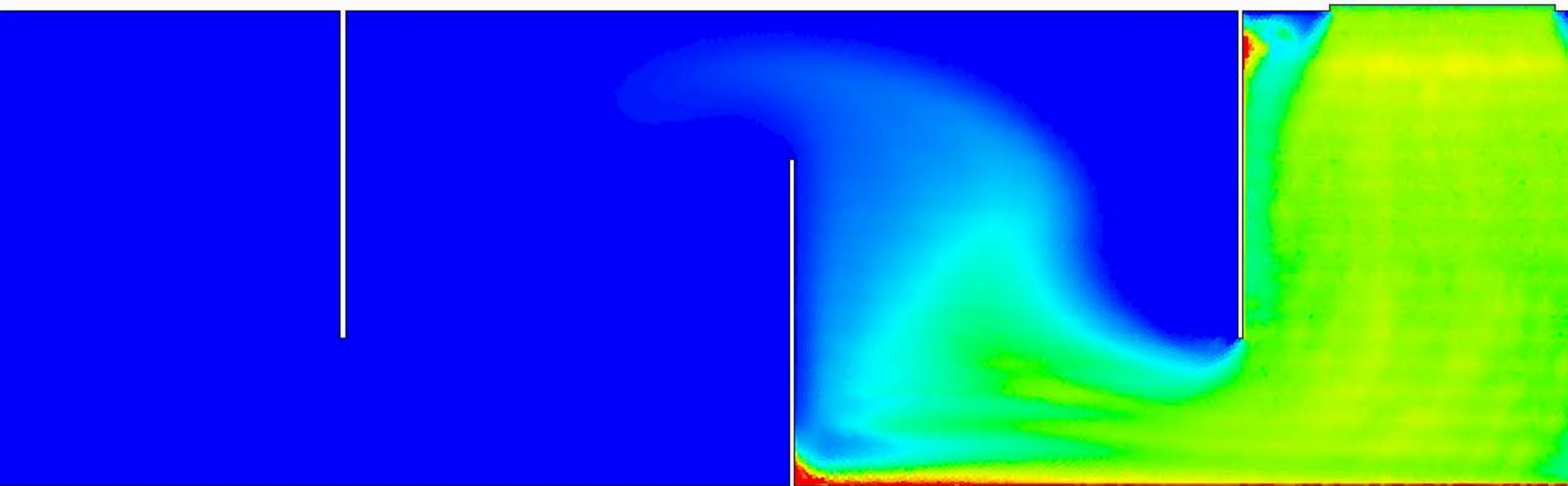

Solution Time 1.501 (s)

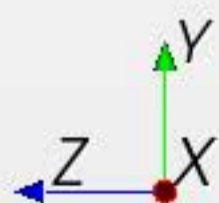
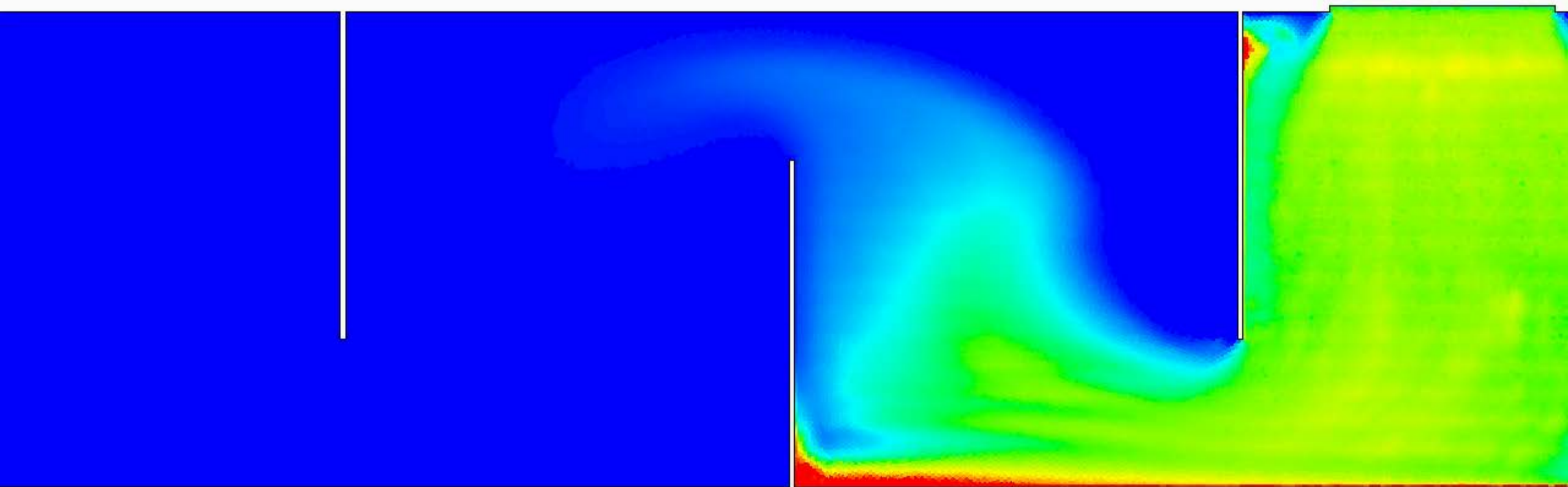

Solution Time 1.601 (s)

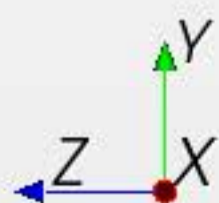
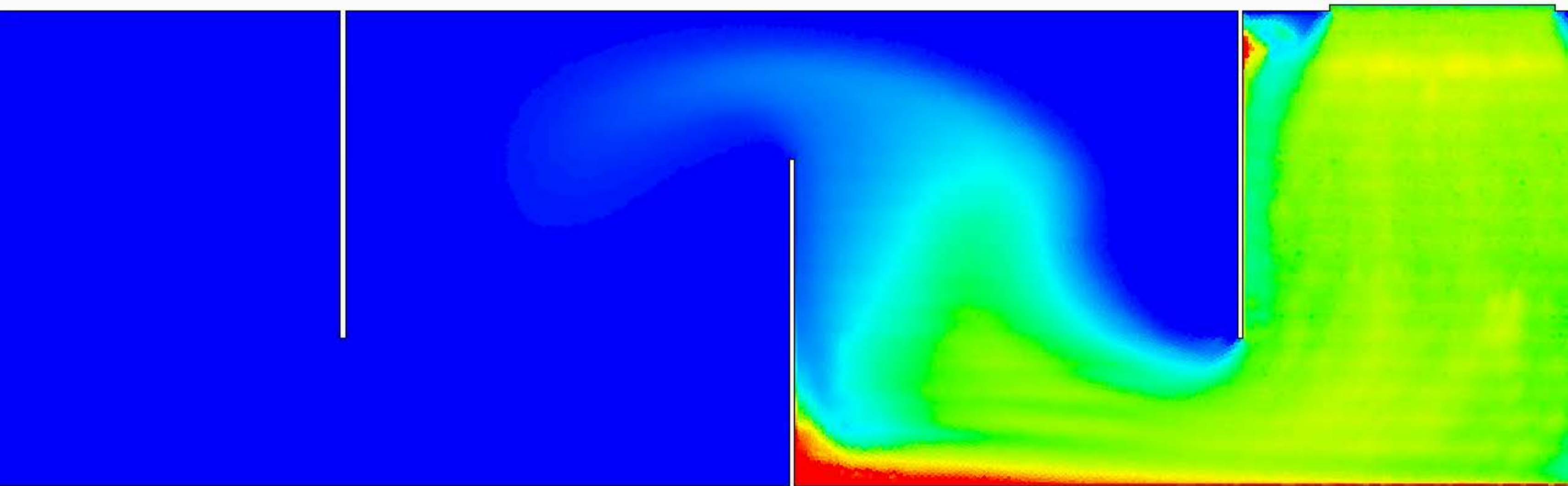

Solution Time 1.701 (s)

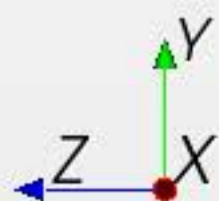
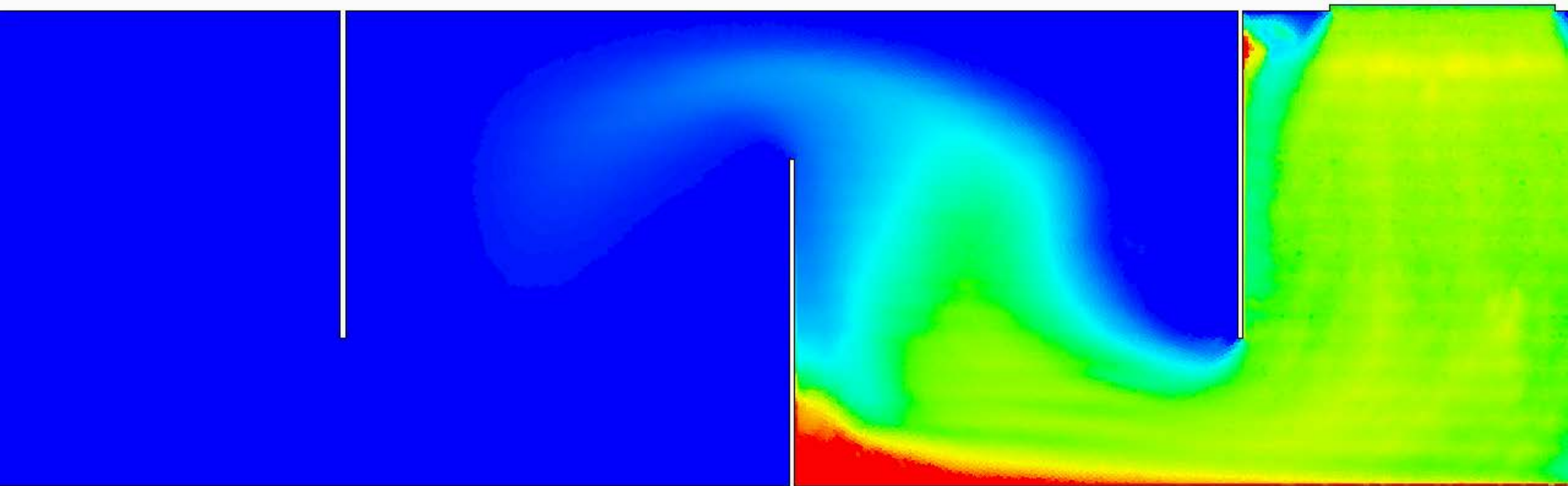

Volume Fraction of Sand

9.8608e-32	0.16000	0.32000	0.48000	0.64000	0.80000
------------	---------	---------	---------	---------	---------

Solution Time 1.801 (s)

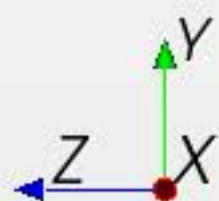
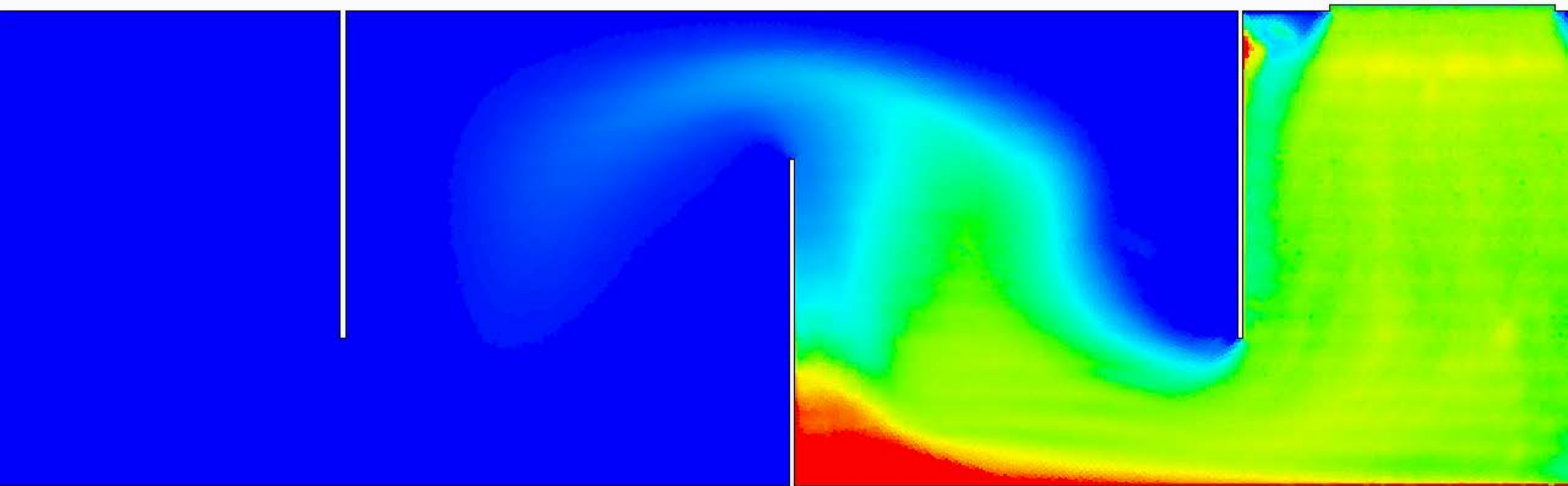

Volume Fraction of Sand

$9.8608e-32$	0.16000	0.32000	0.48000	0.64000	0.80000
--------------	---------	---------	---------	---------	---------



Solution Time 1.901 (s)

Volume Fraction of Sand

Appendix K

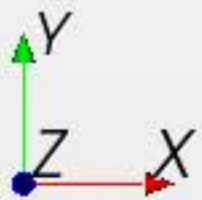
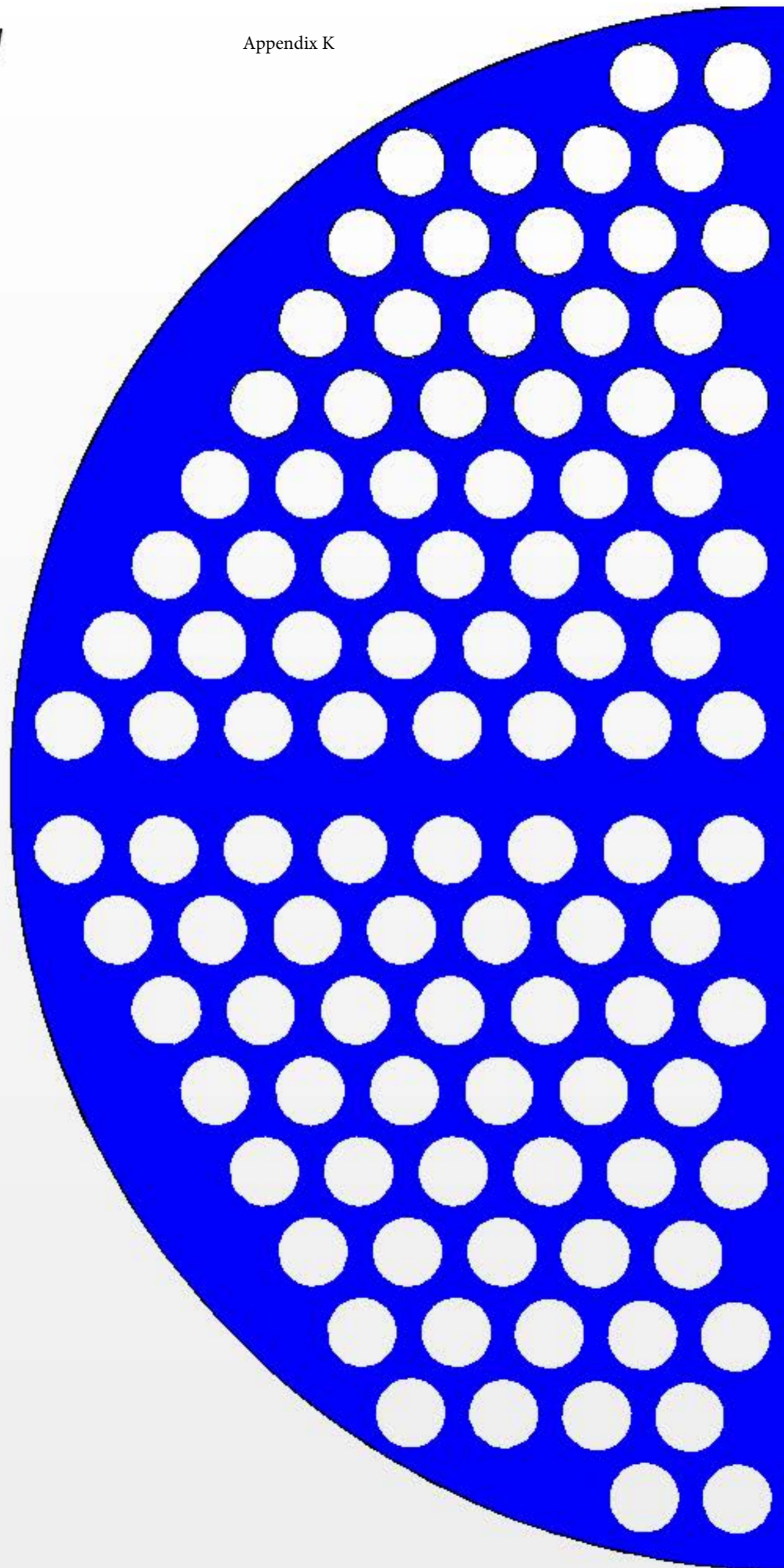

Volume Fraction of Sand

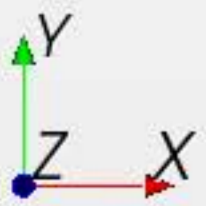
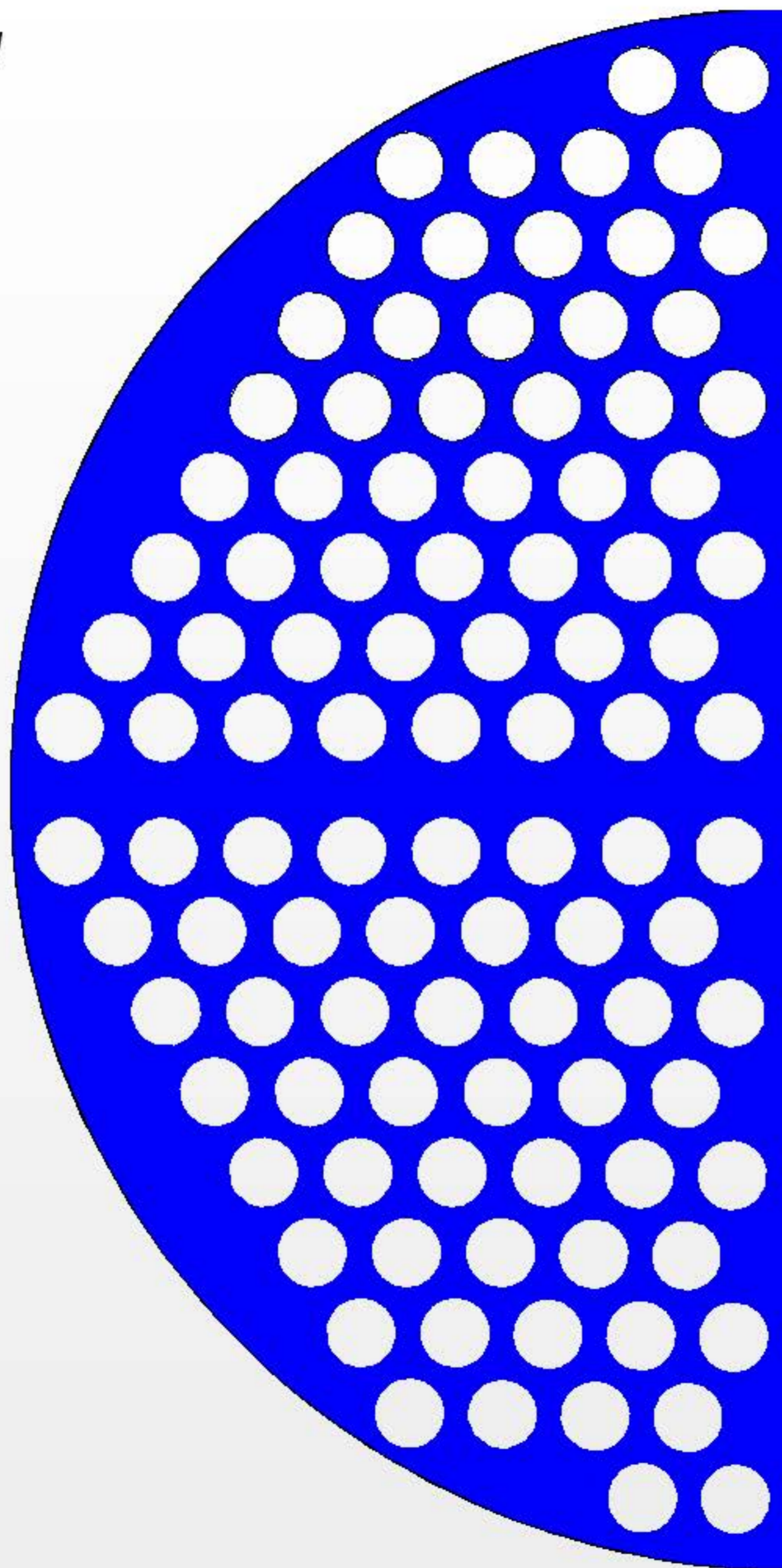

Volume Fraction of Sand

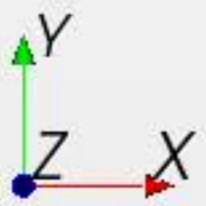
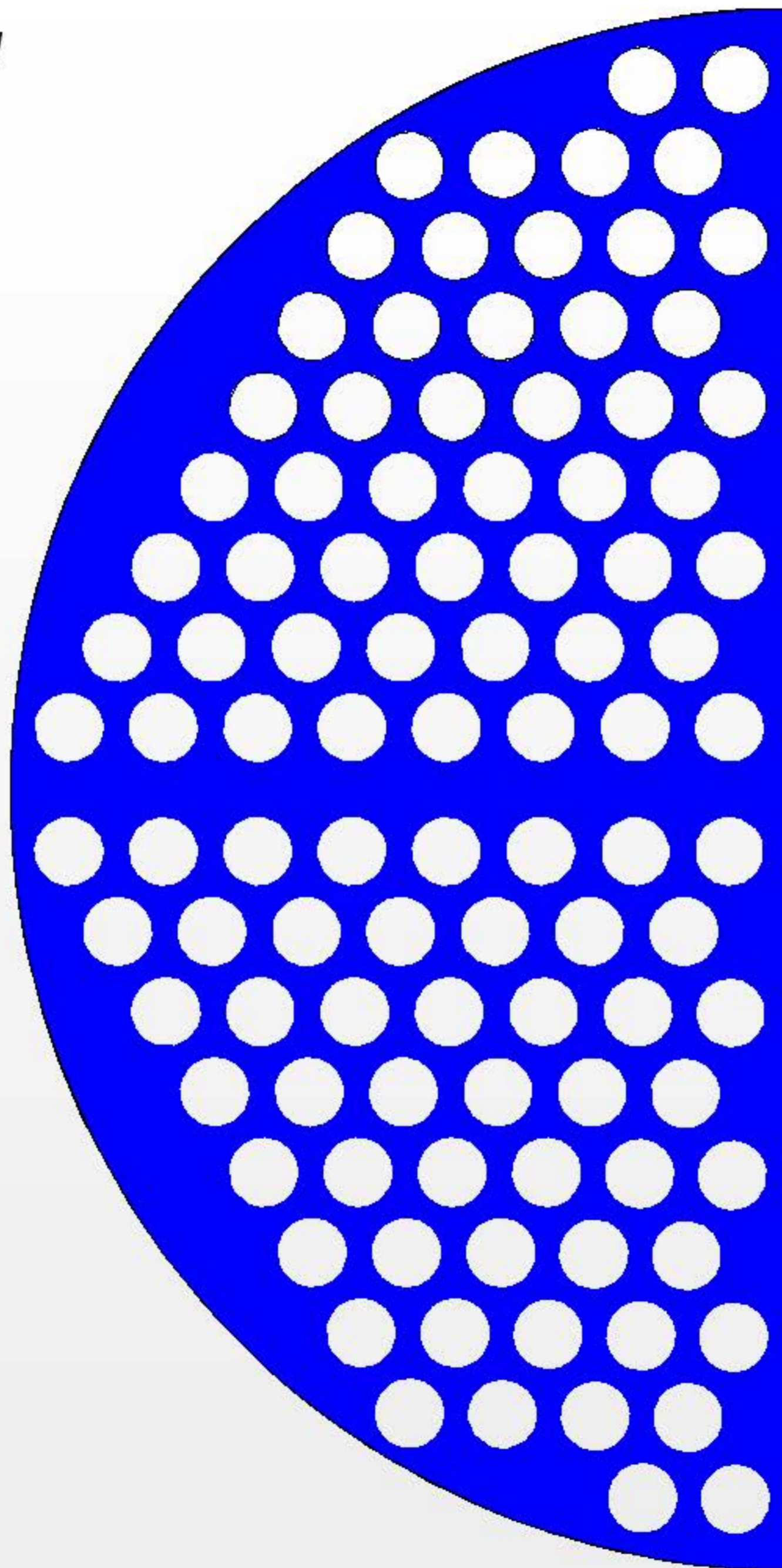

Volume Fraction of Sand

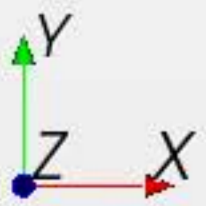
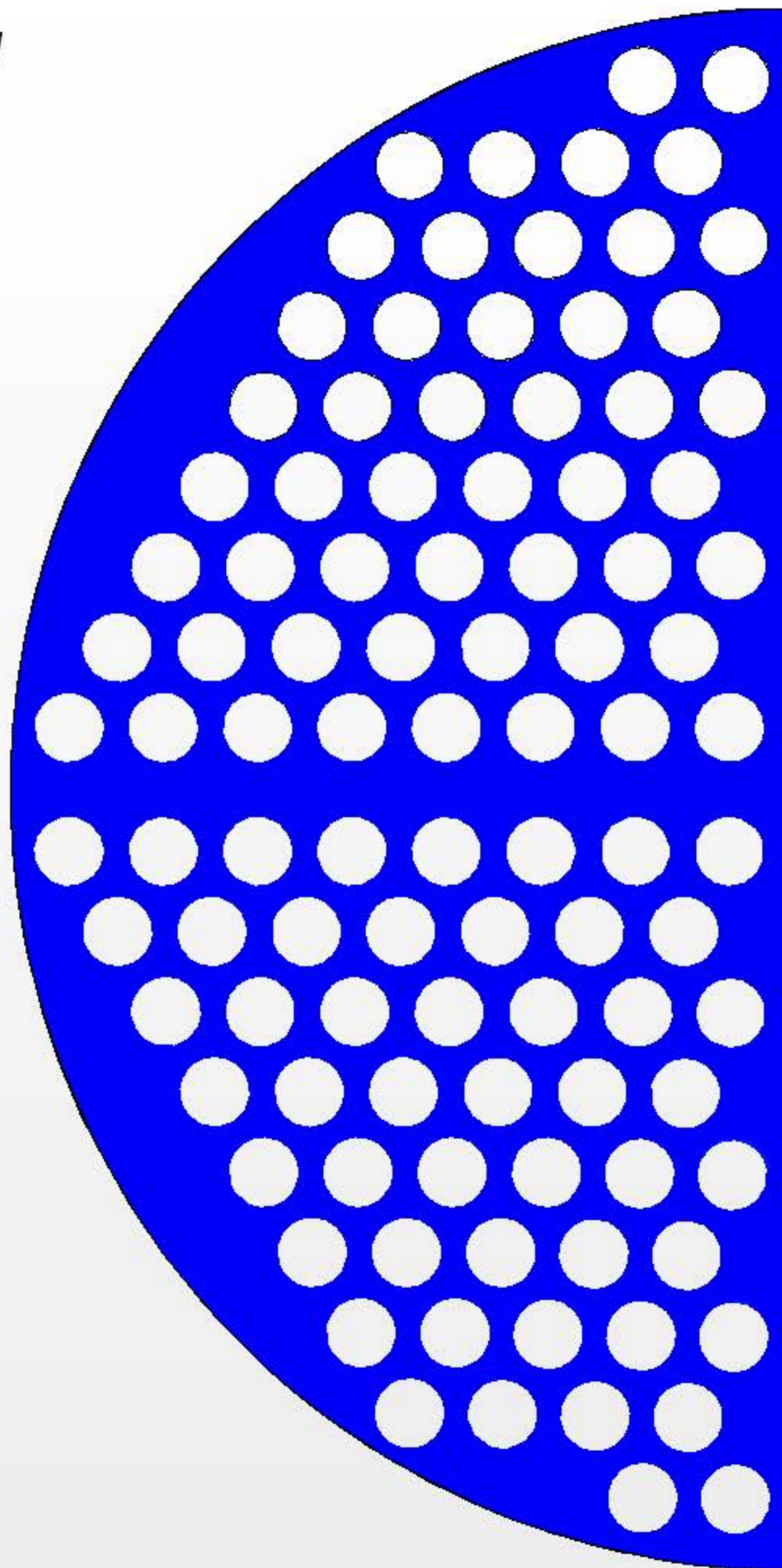

Volume Fraction of Sand

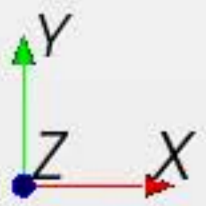
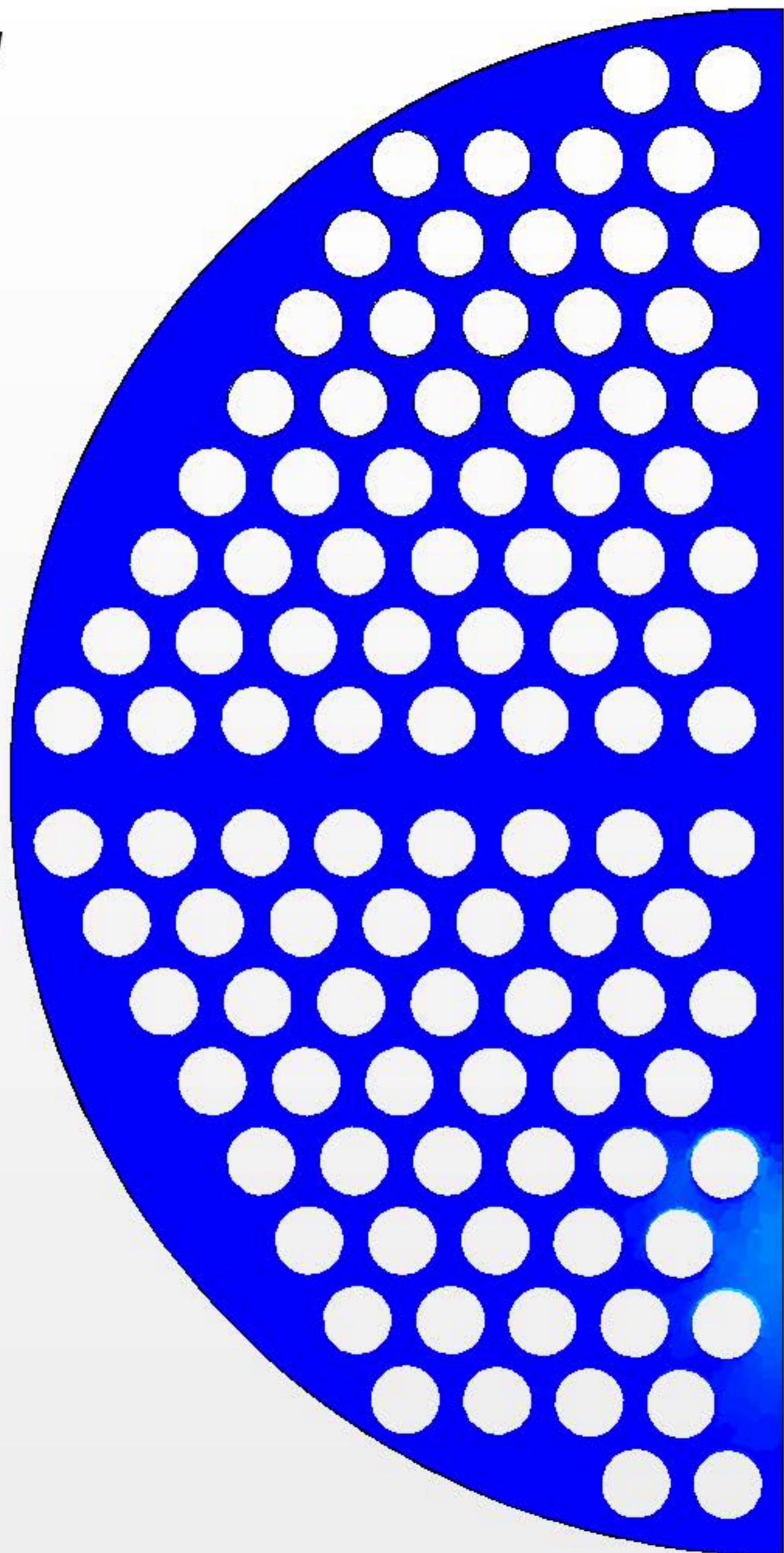

Volume Fraction of Sand

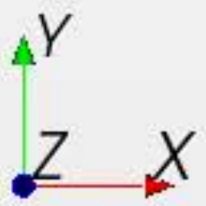
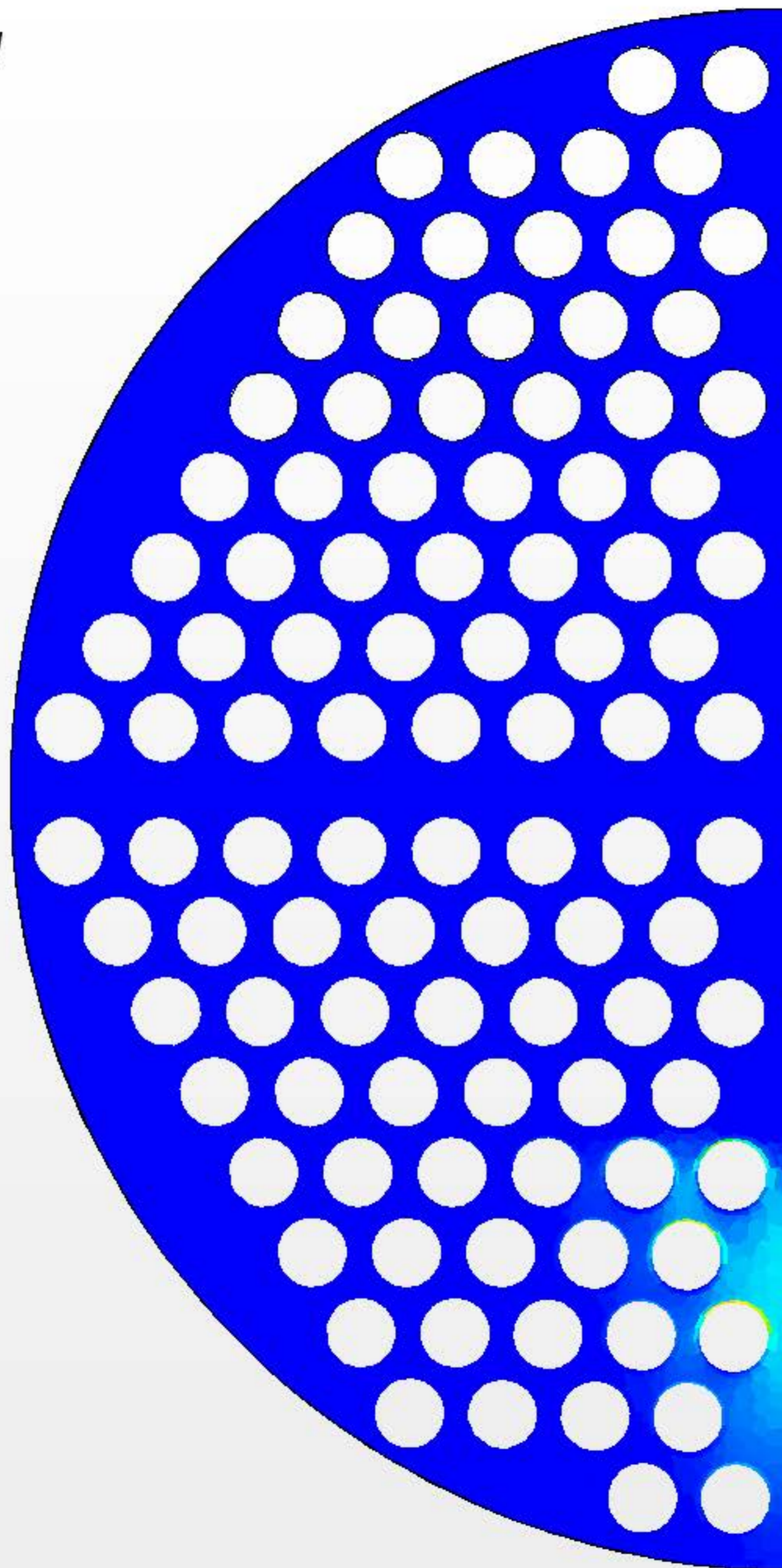

Volume Fraction of Sand

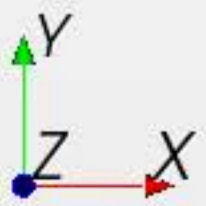
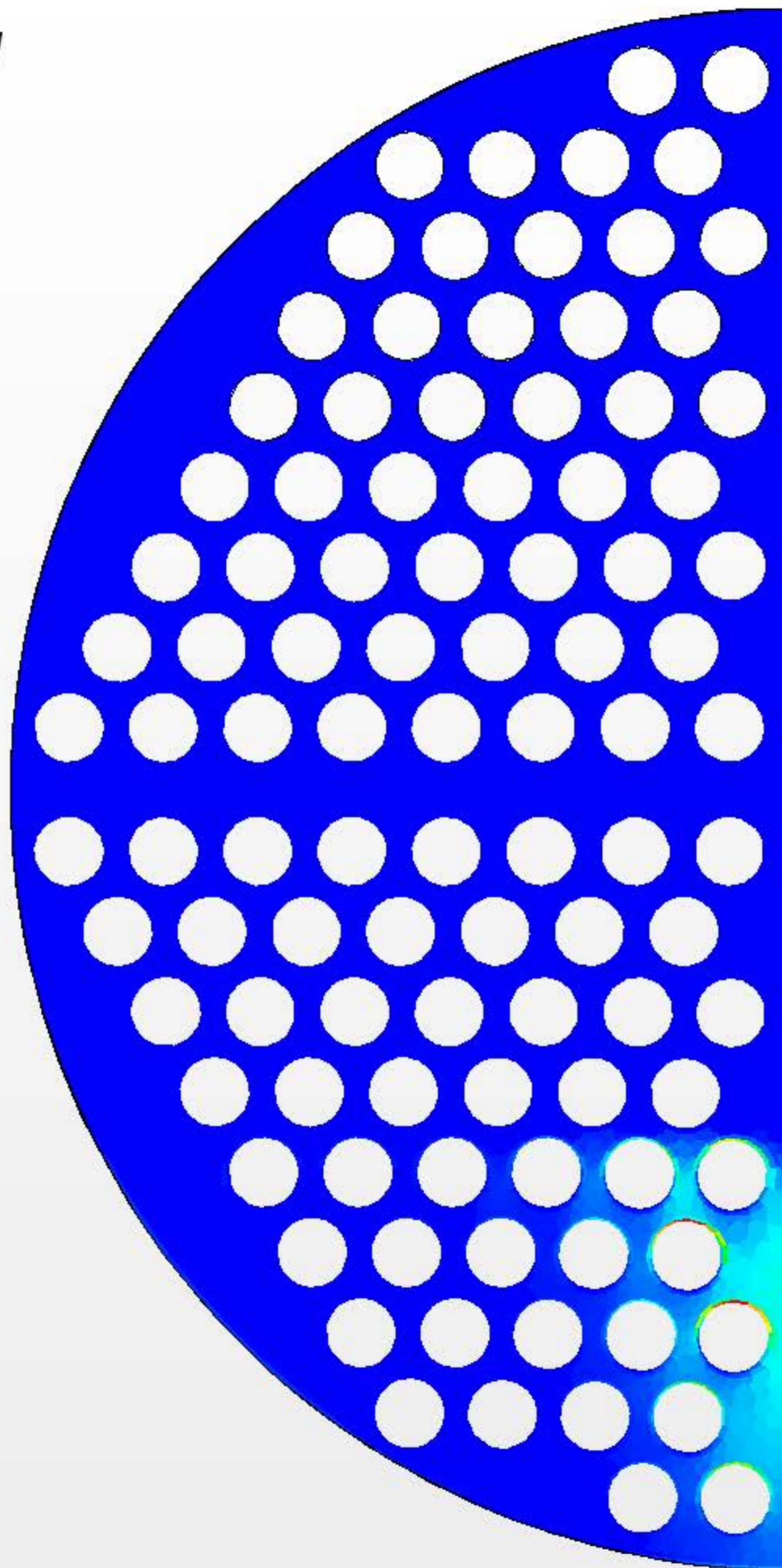

Volume Fraction of Sand

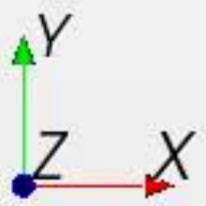
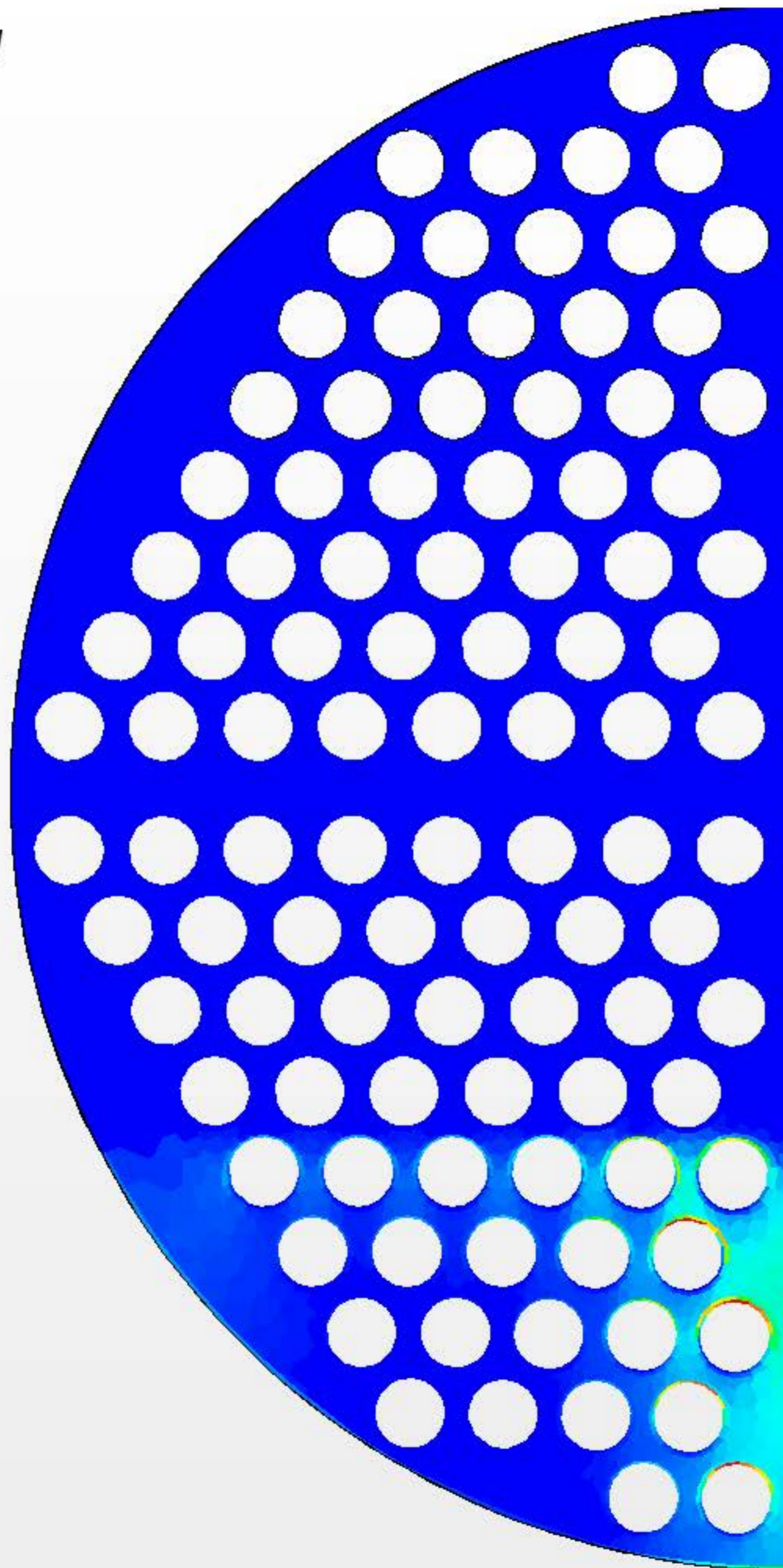

Volume Fraction of Sand

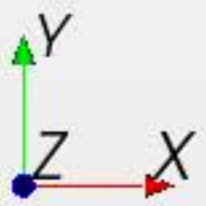
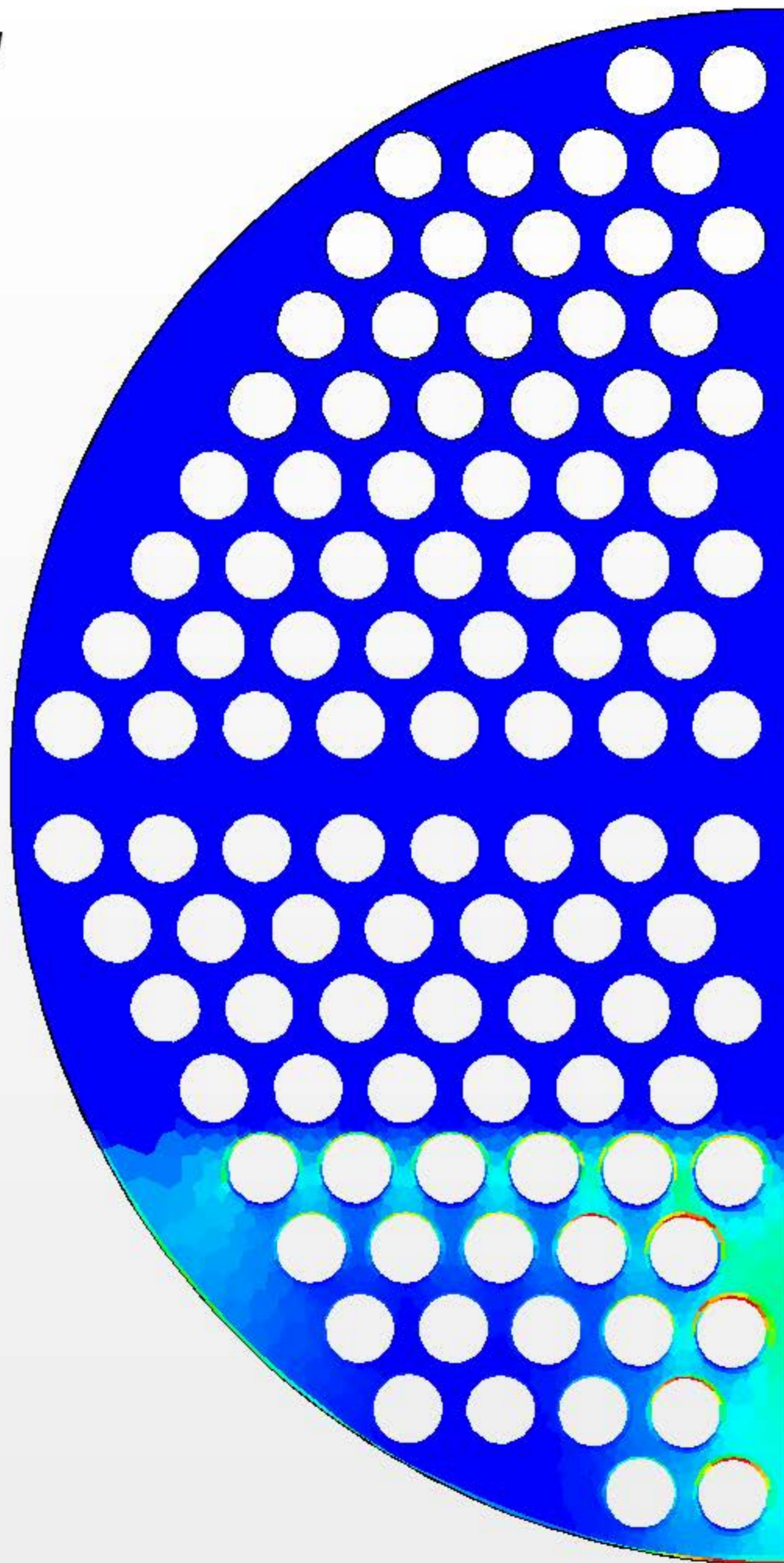

Volume Fraction of Sand

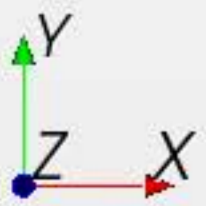
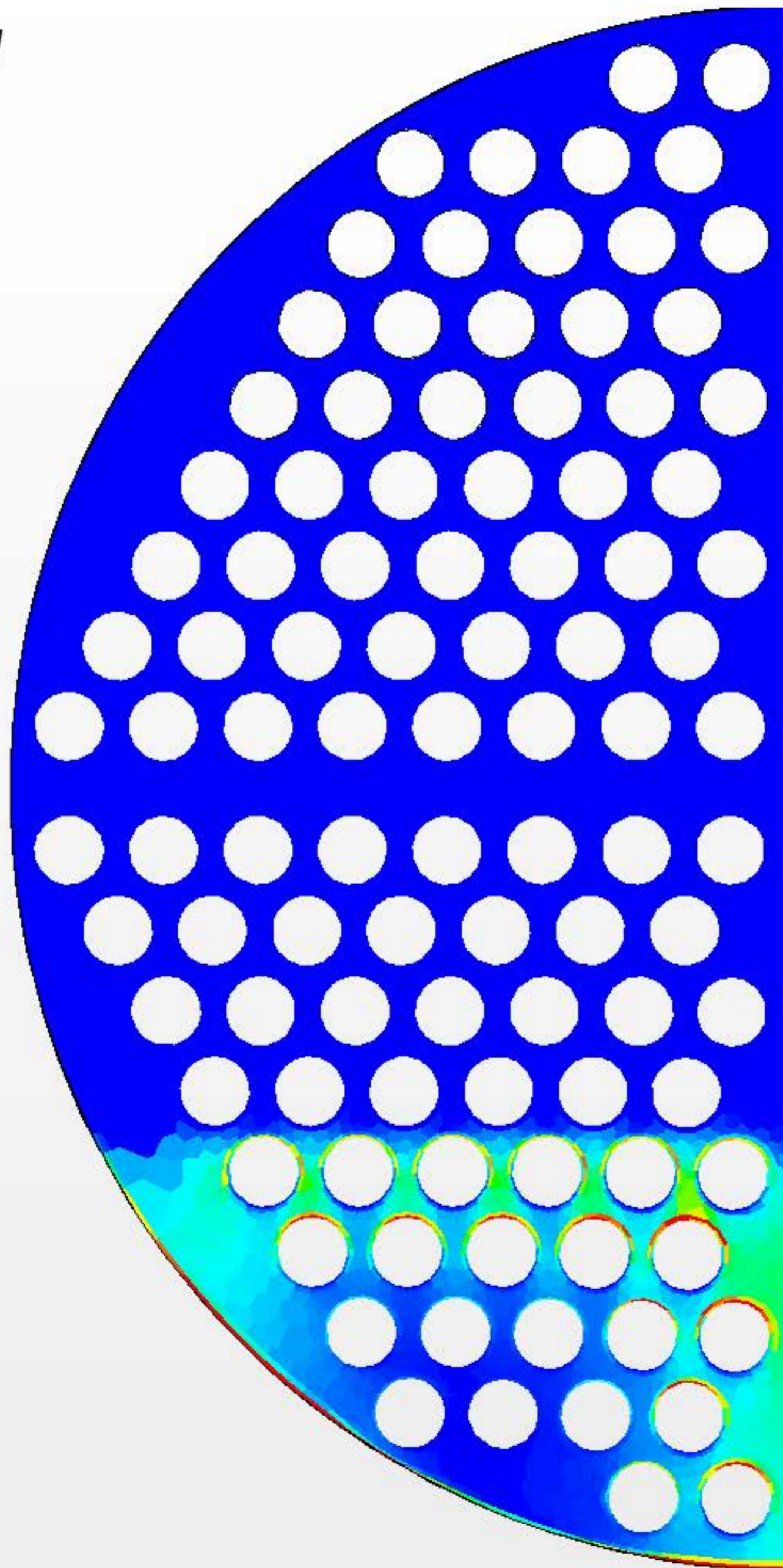

Volume Fraction of Sand

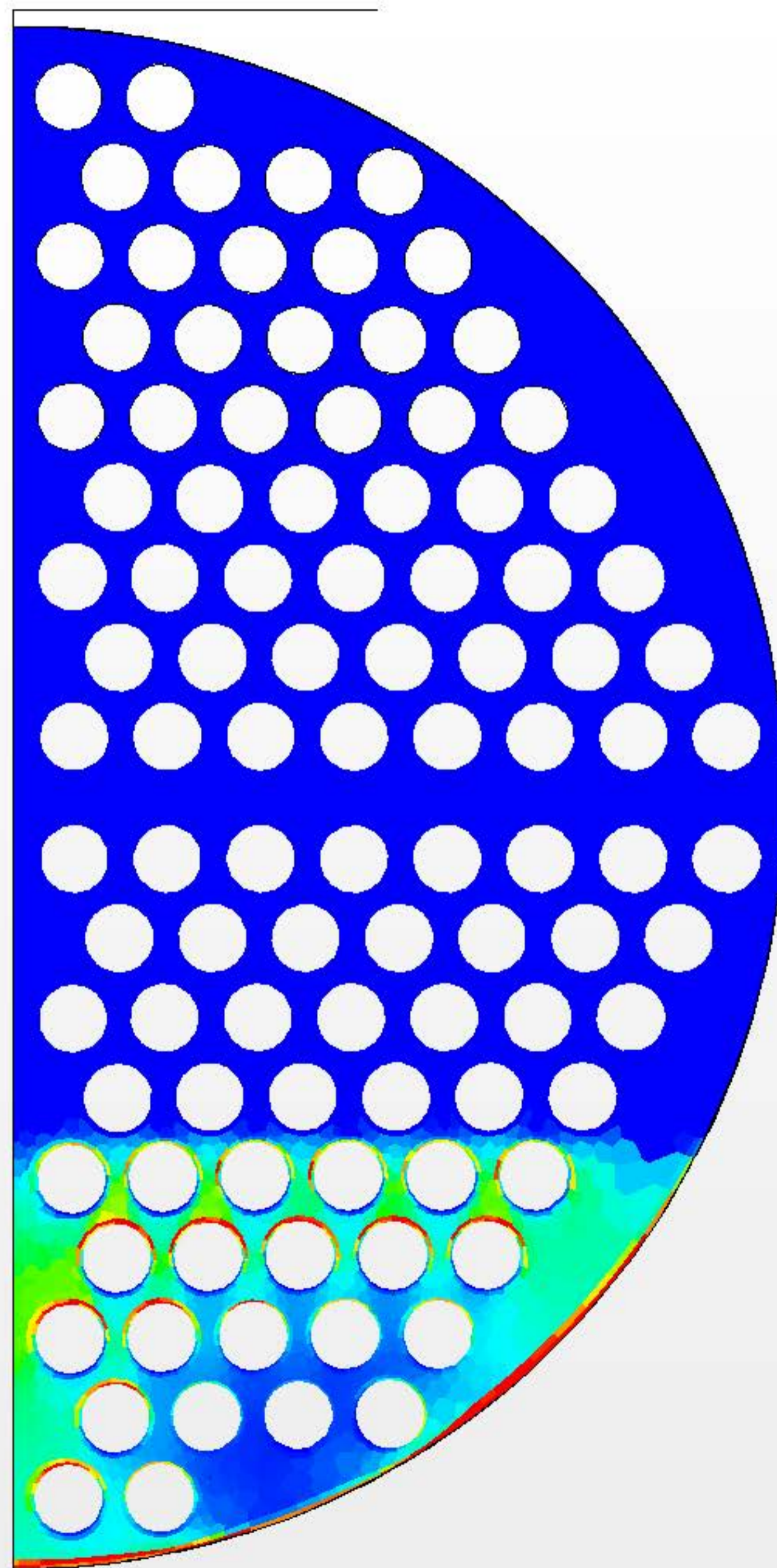
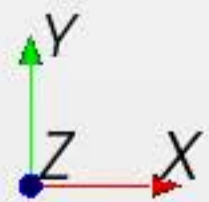
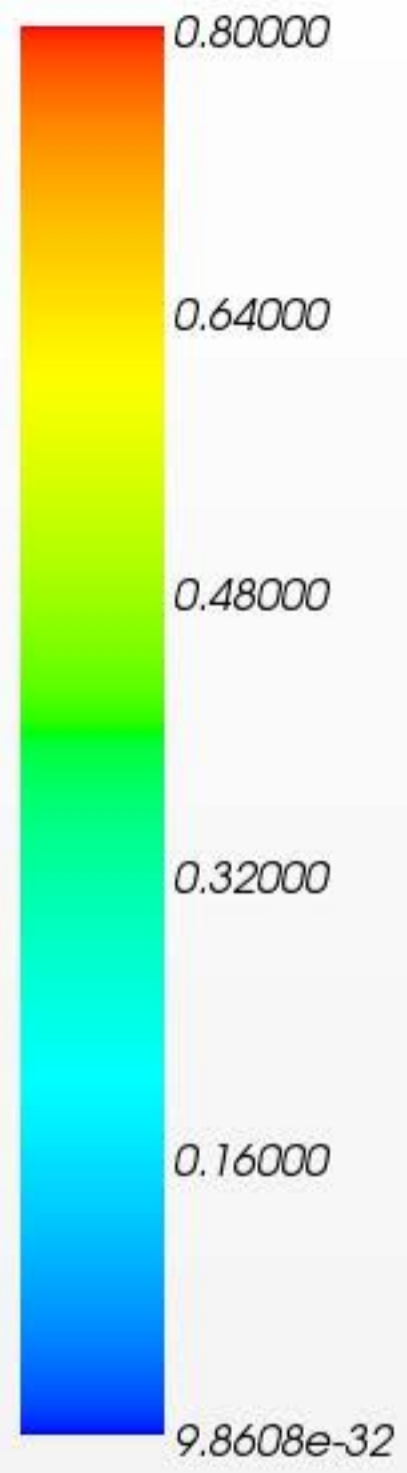

Volume Fraction of Sand

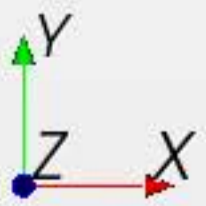
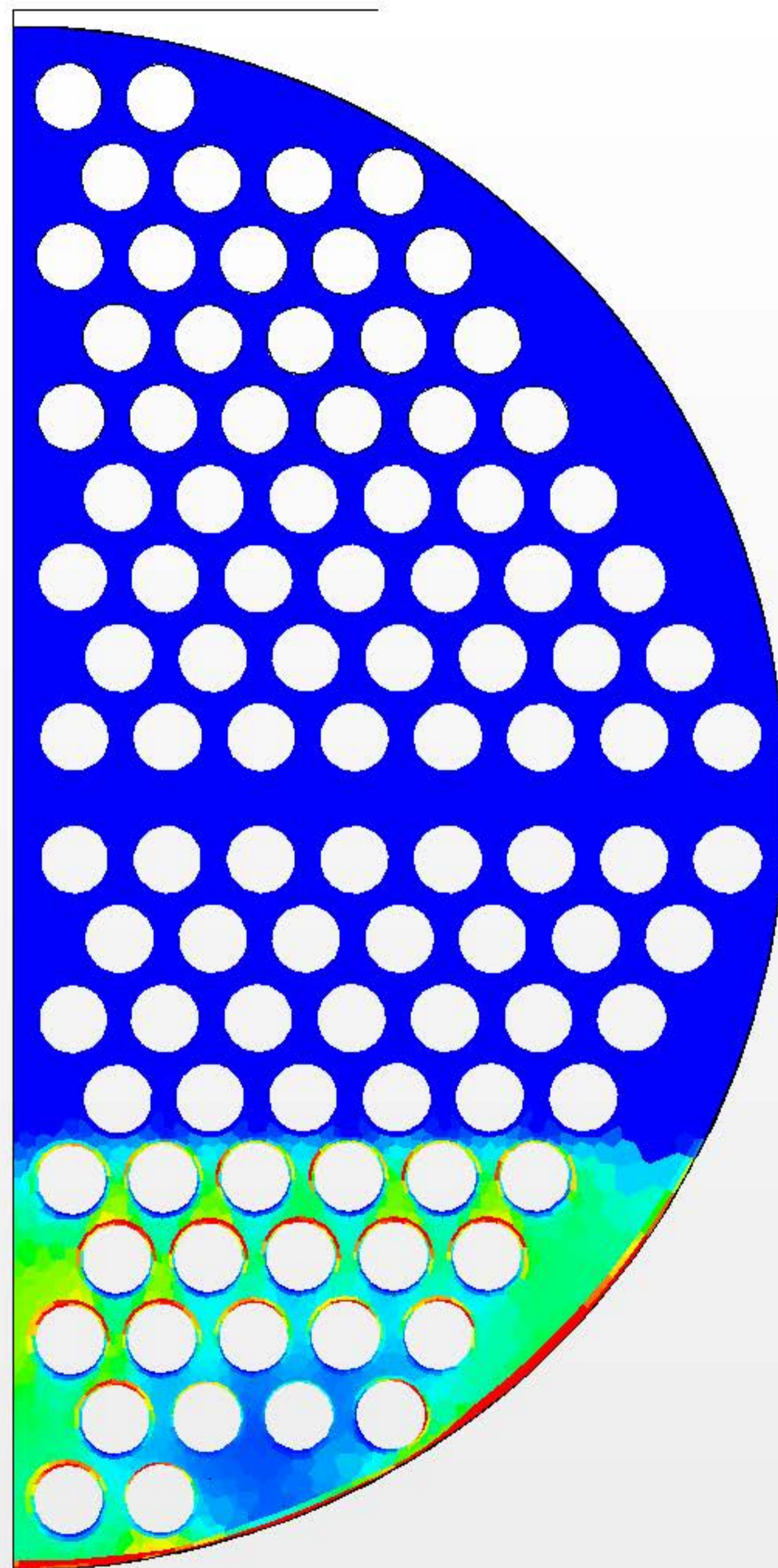

Volume Fraction of Sand

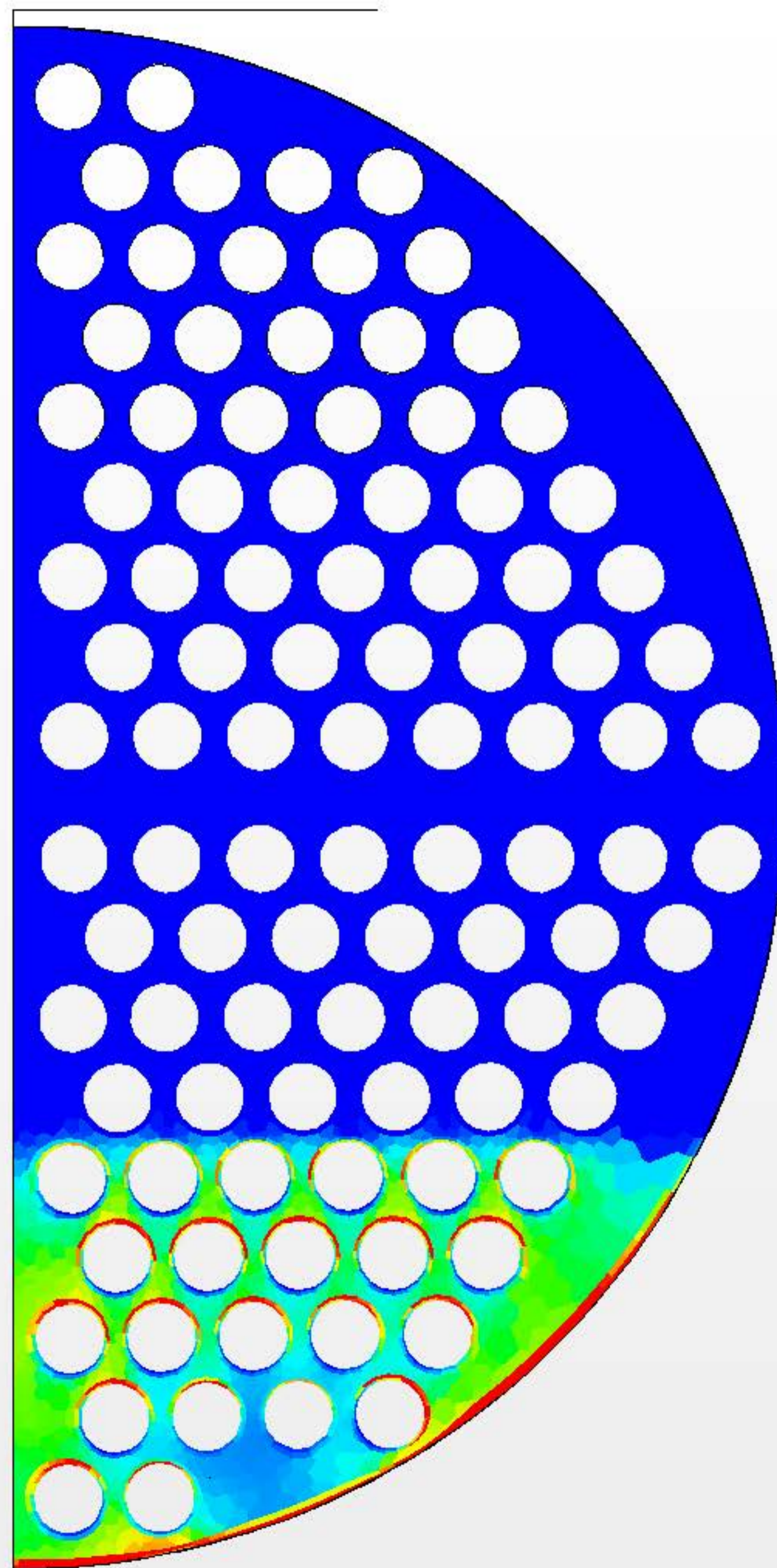
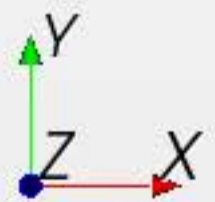
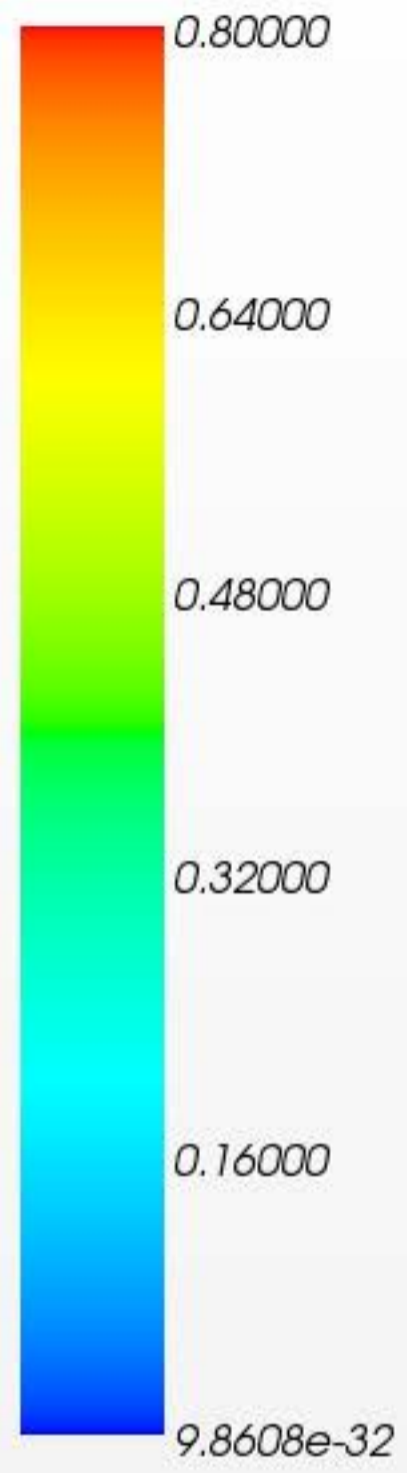

Volume Fraction of Sand

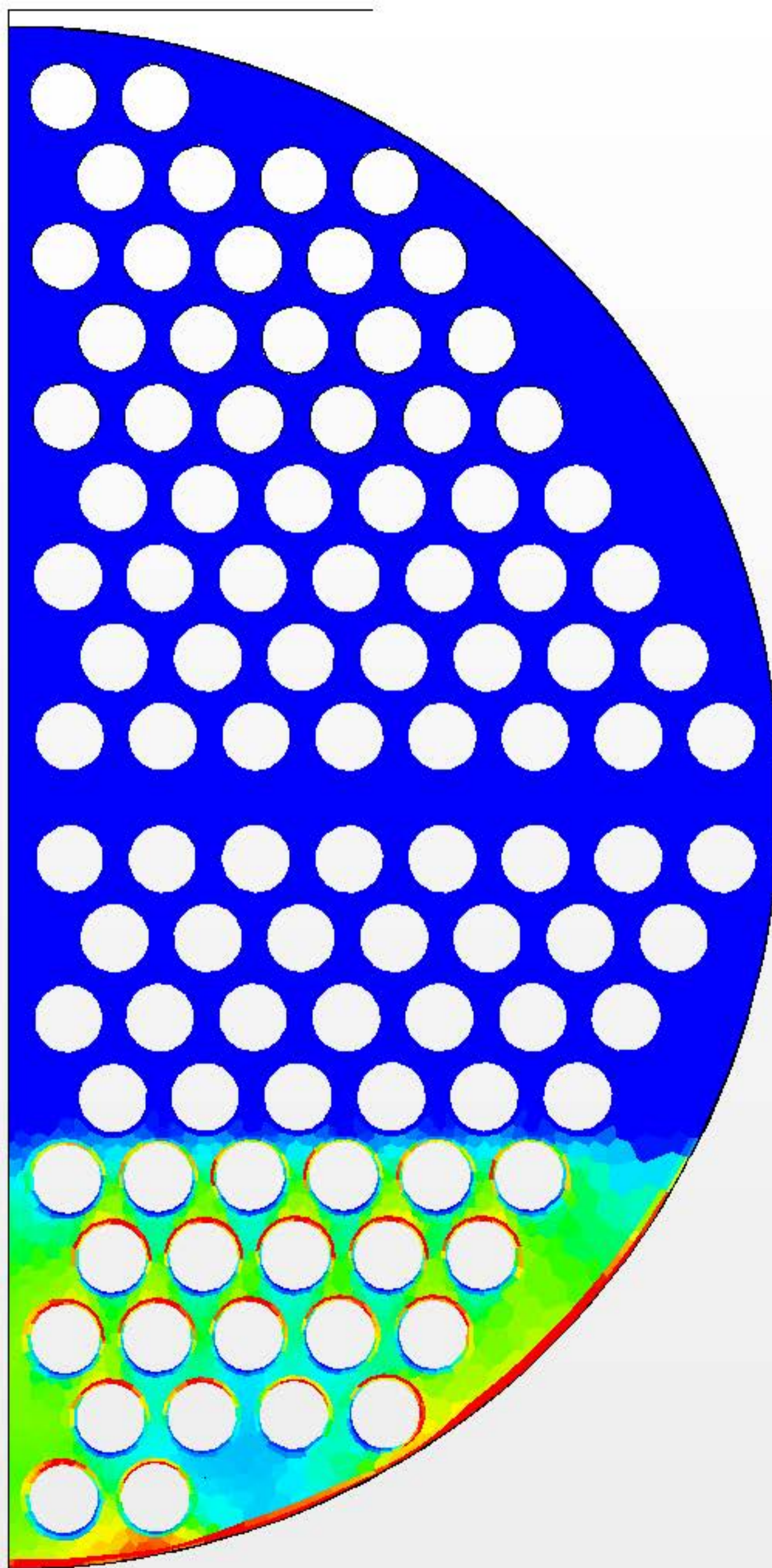
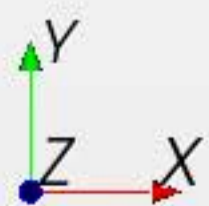

Volume Fraction of Sand

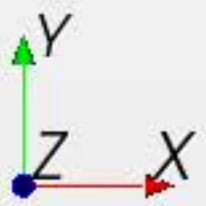
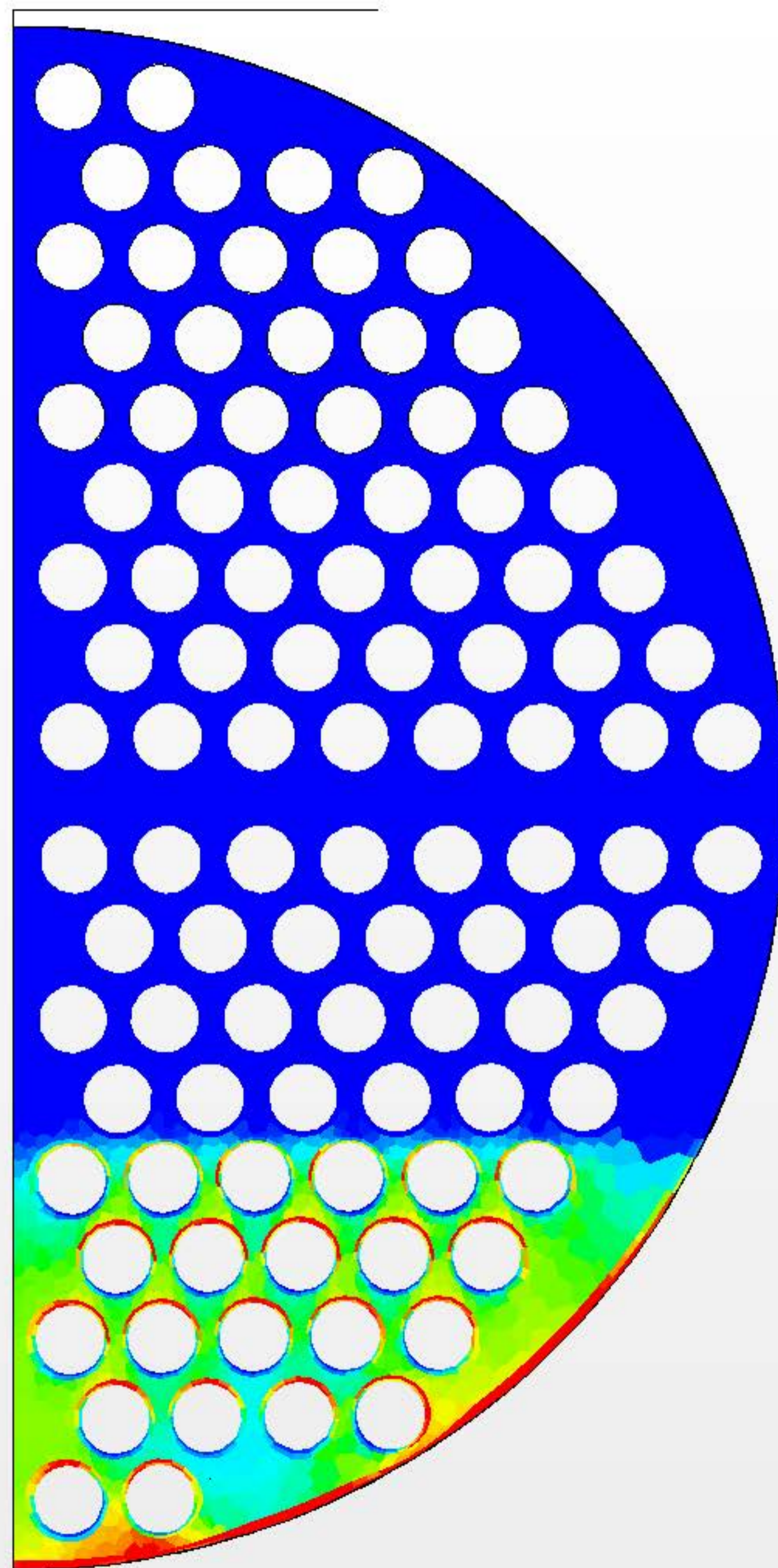

Volume Fraction of Sand

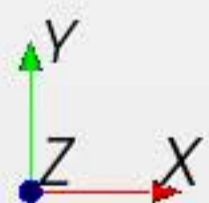
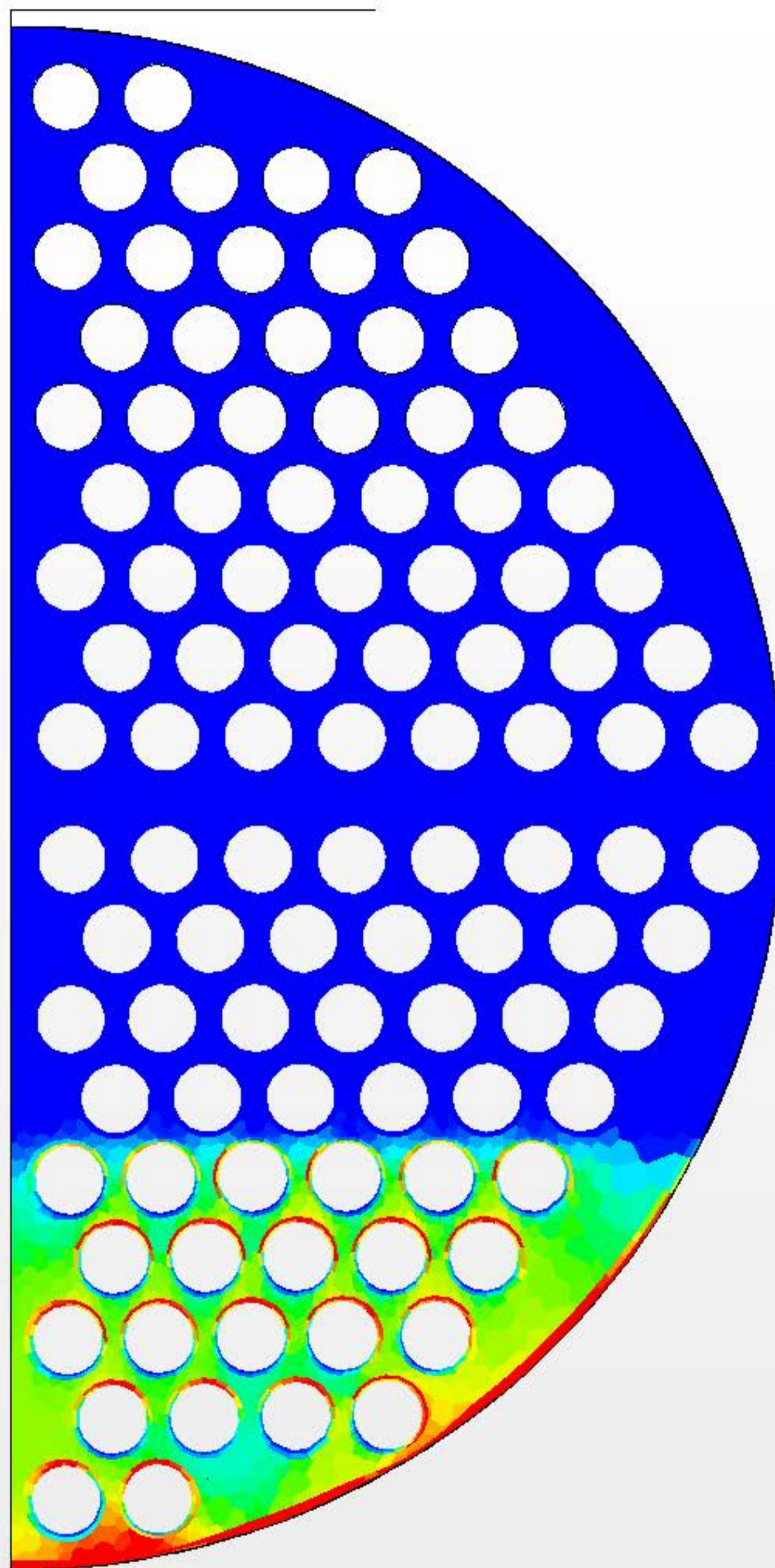

Volume Fraction of Sand

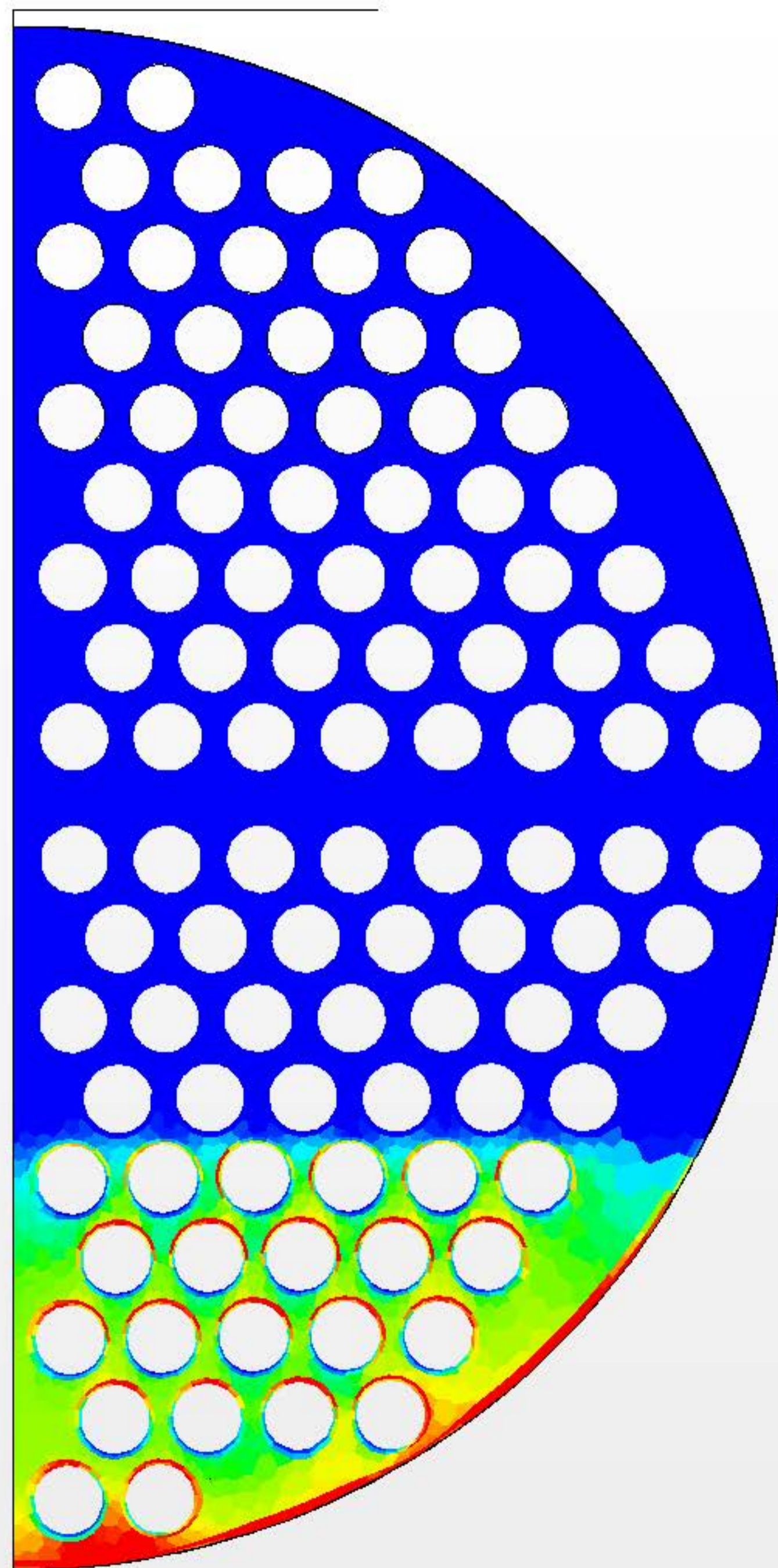
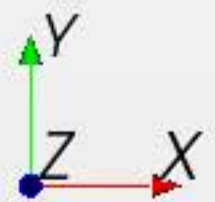

Volume Fraction of Sand

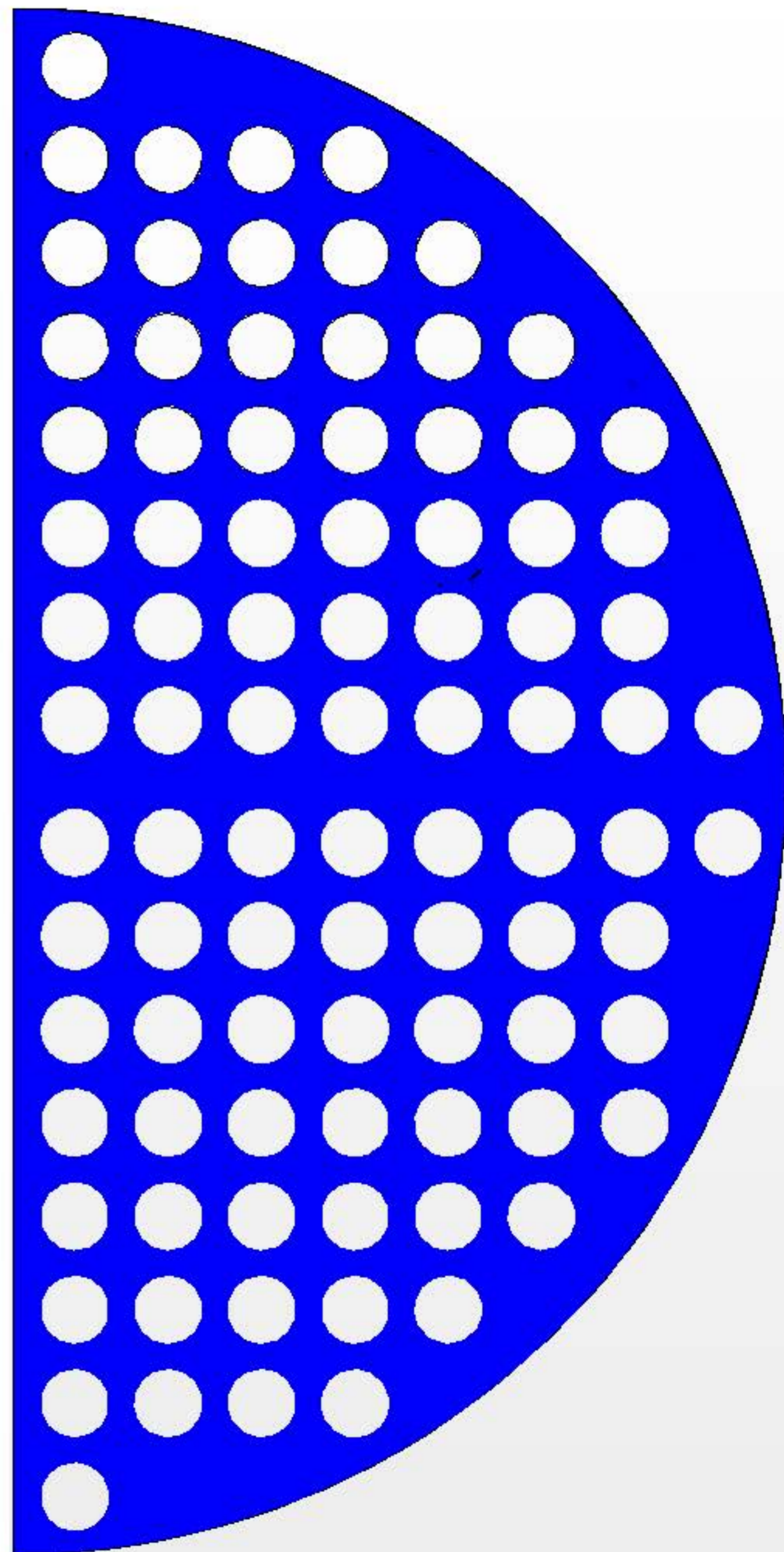
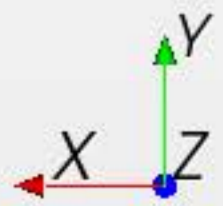

Volume Fraction of Sand

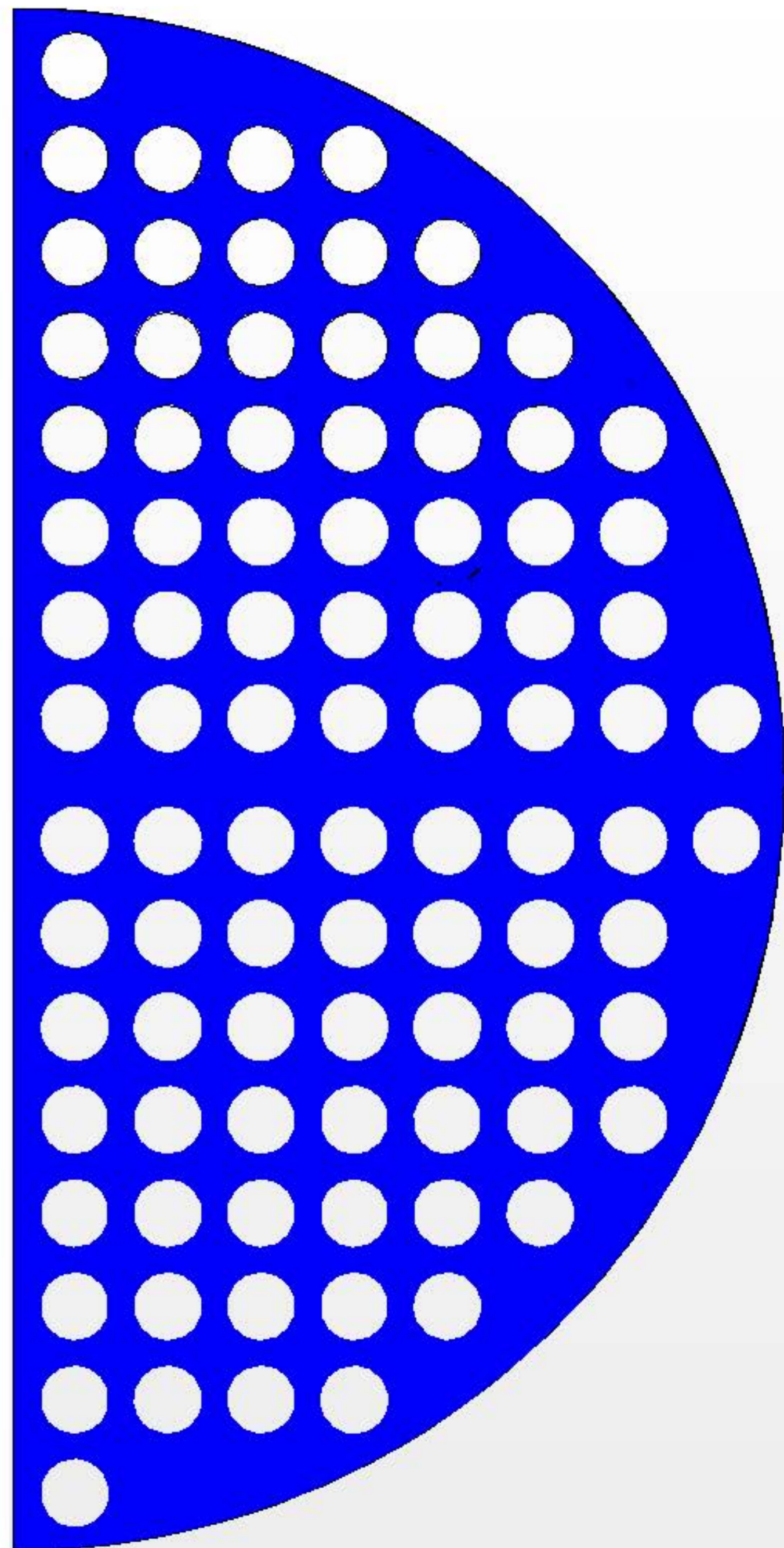
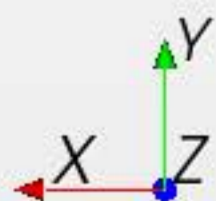

Volume Fraction of Sand

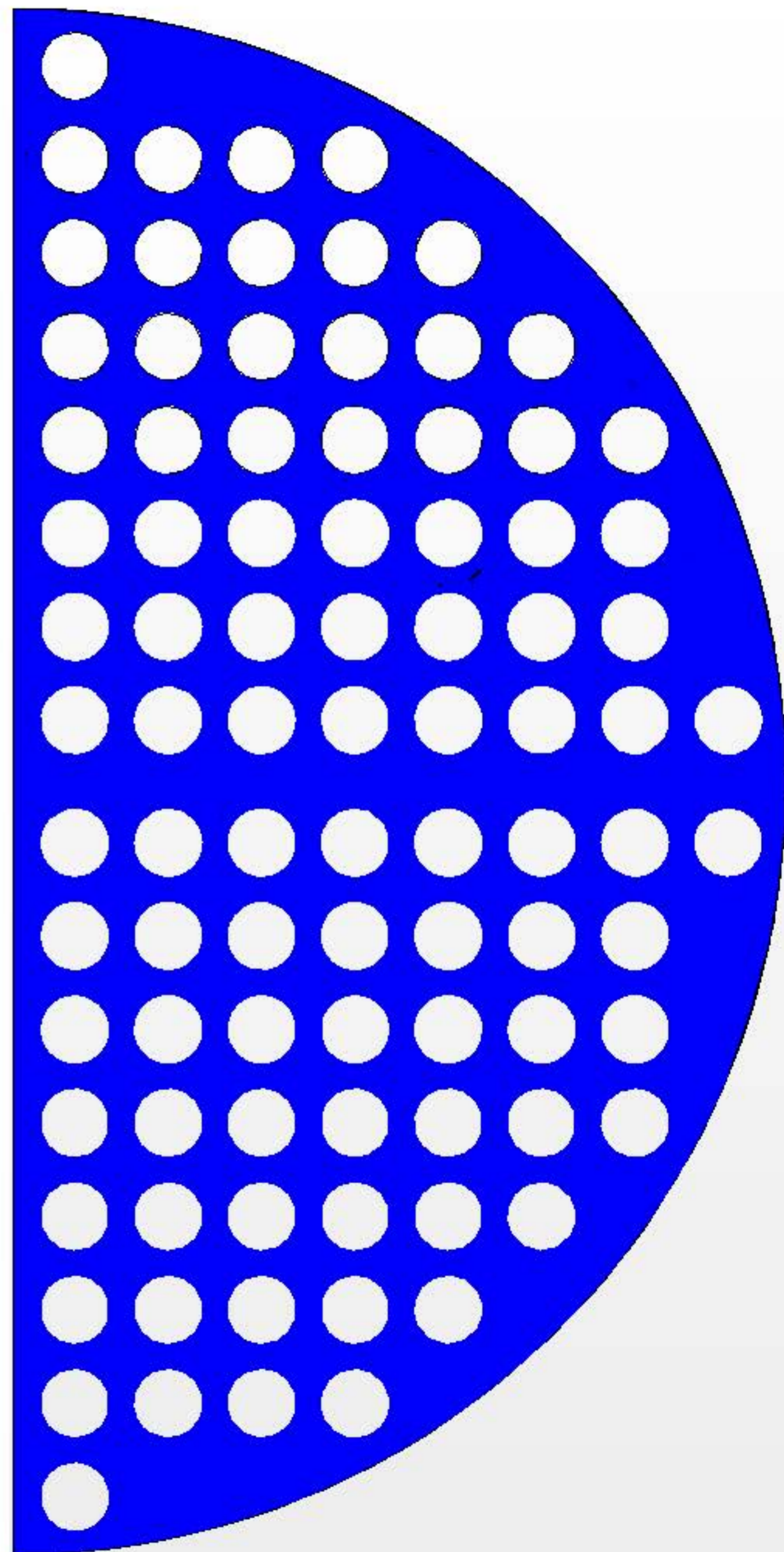
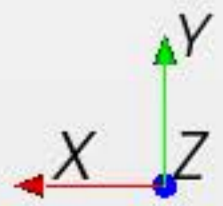

Volume Fraction of Sand

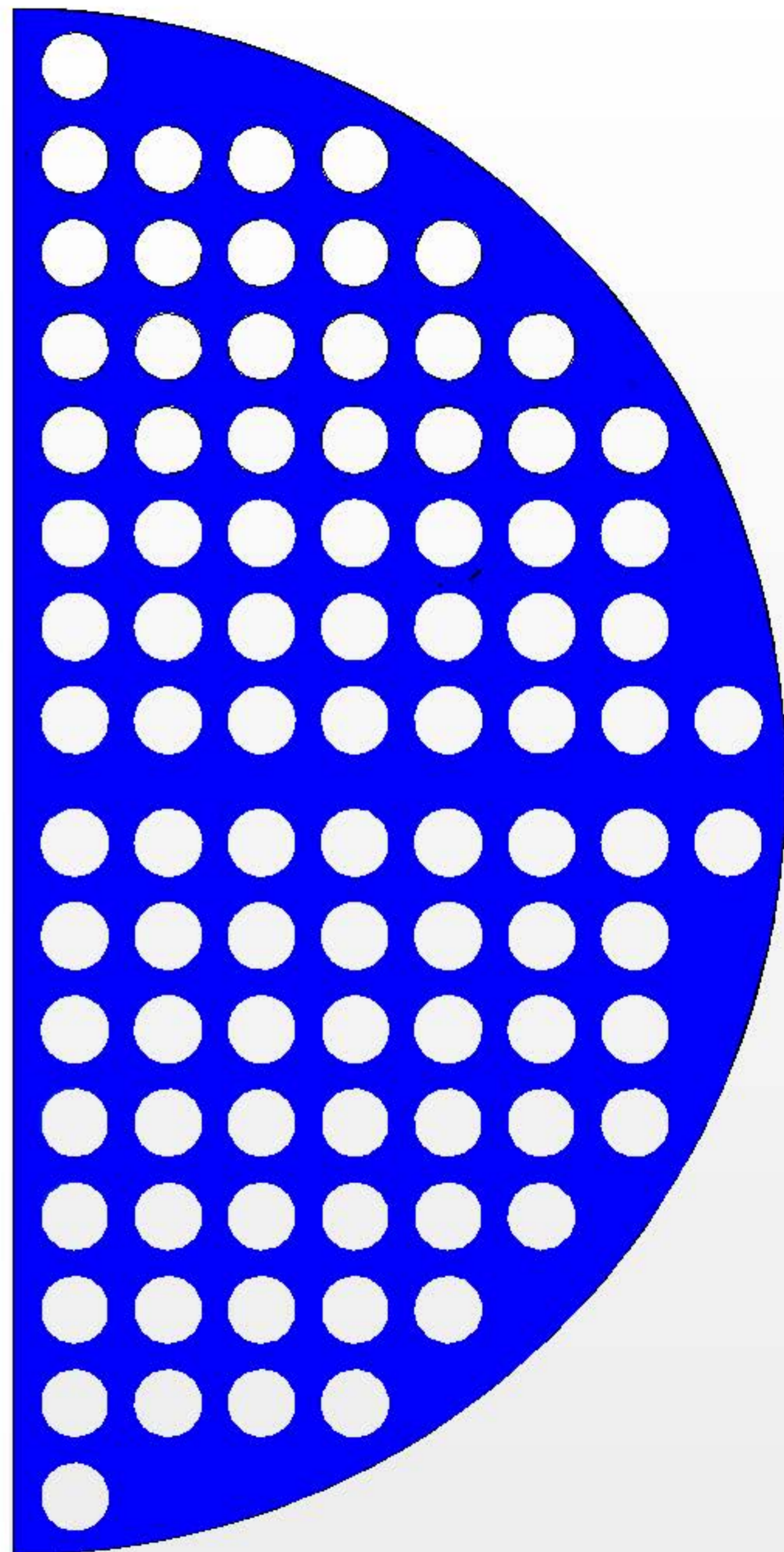
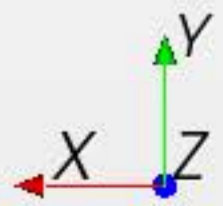

Volume Fraction of Sand

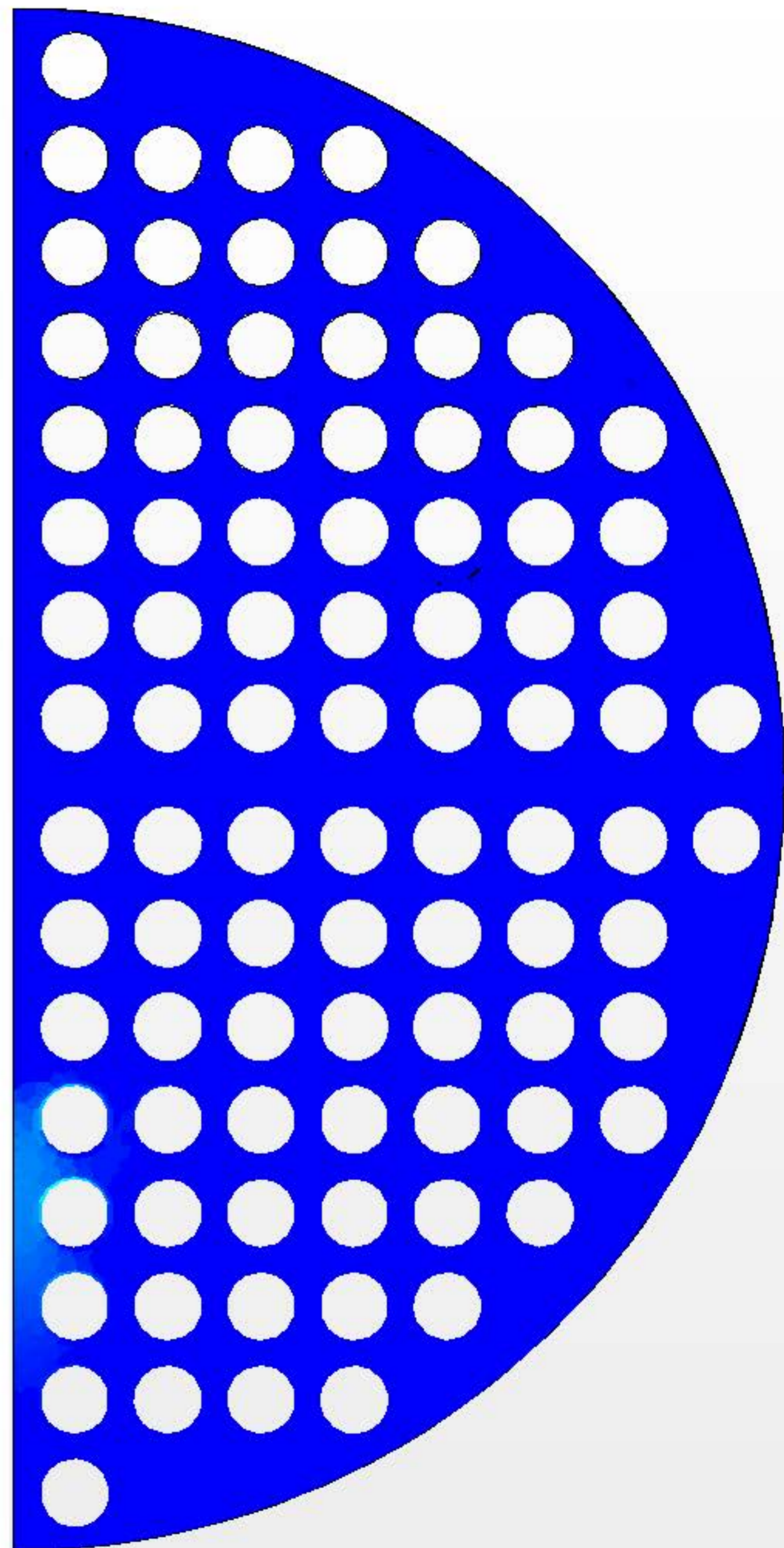
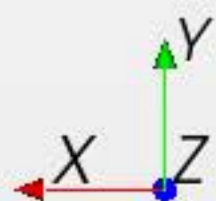
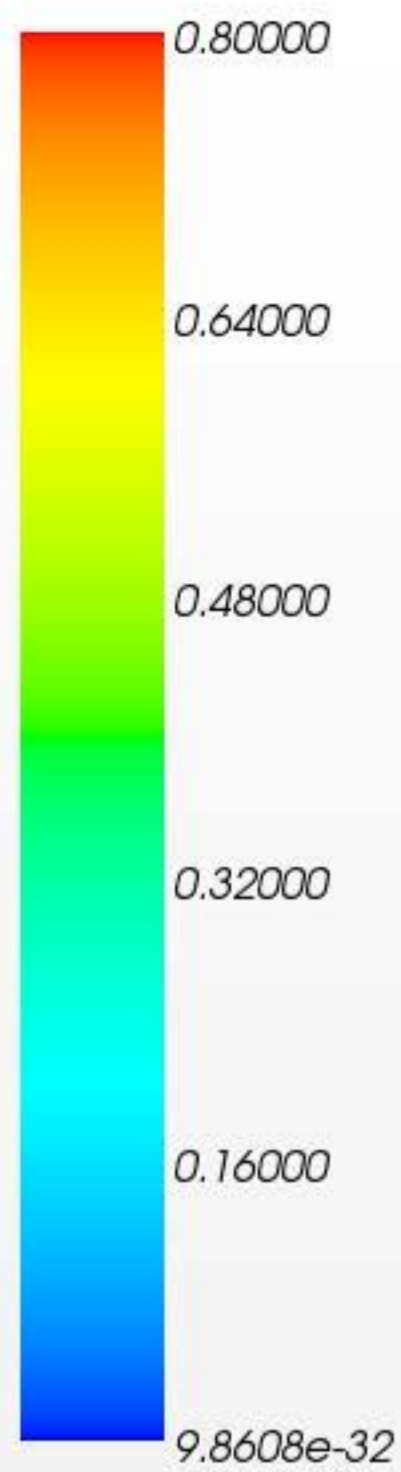

Volume Fraction of Sand

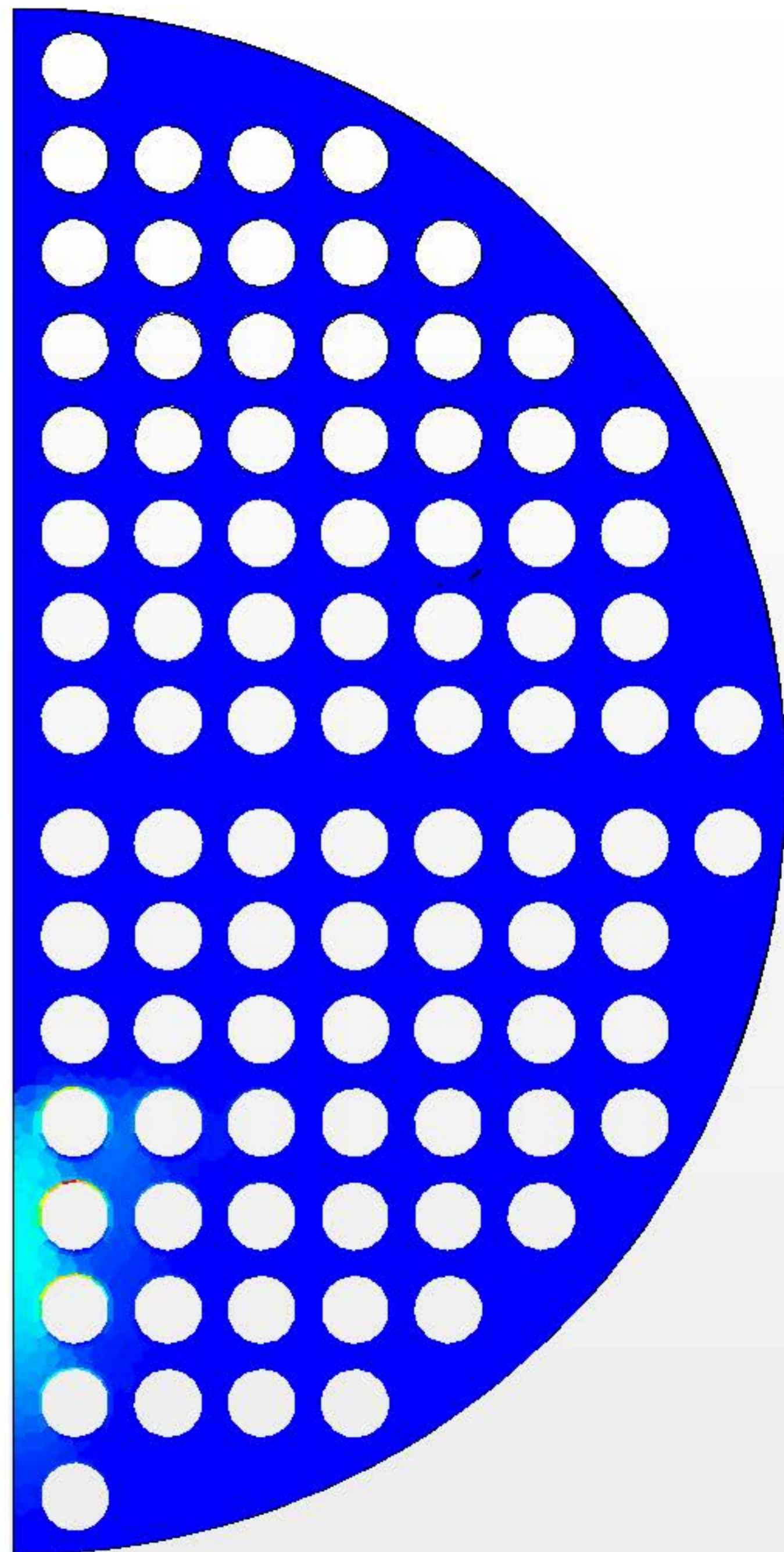
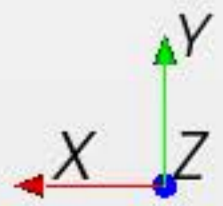

Volume Fraction of Sand

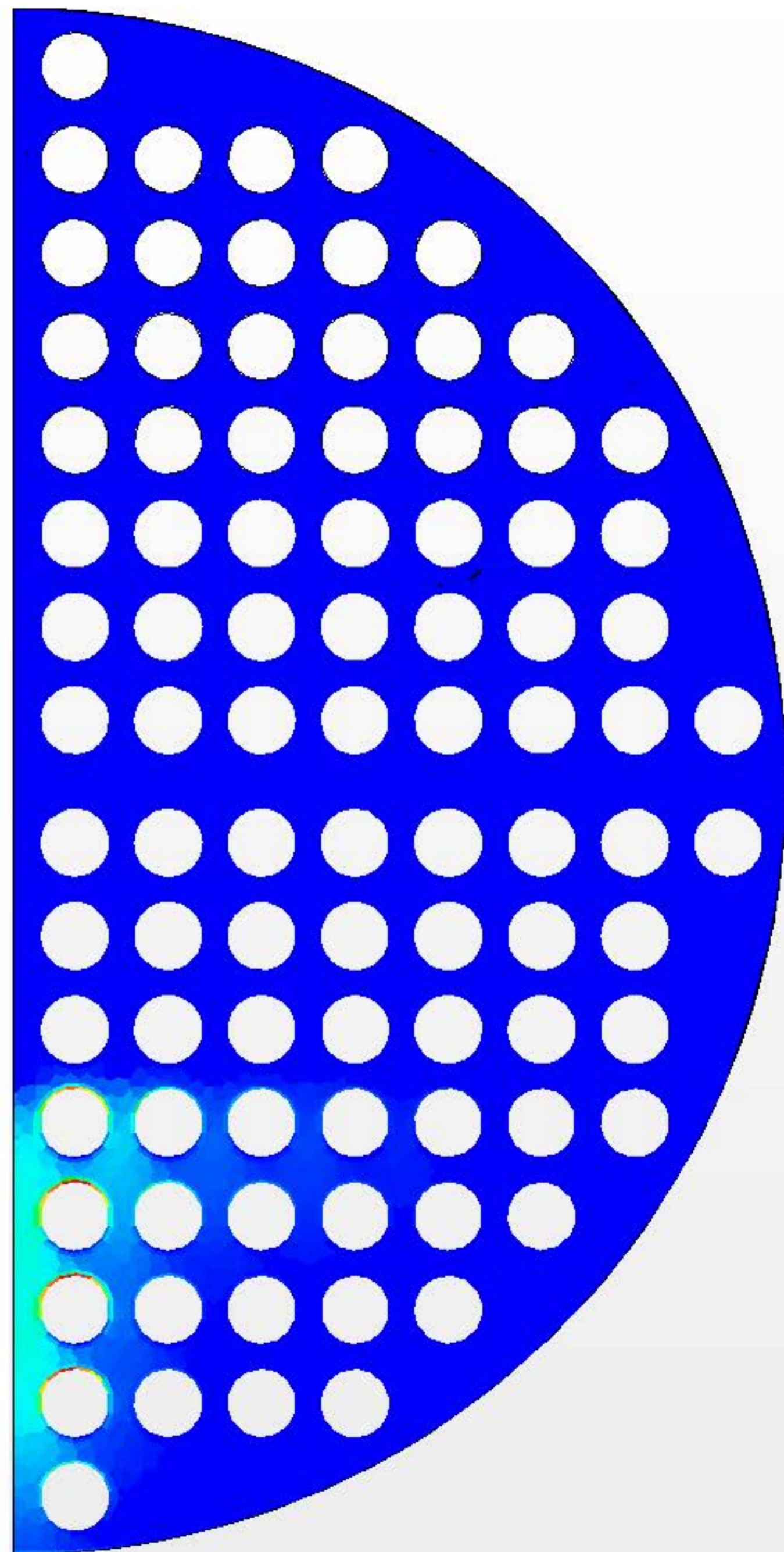
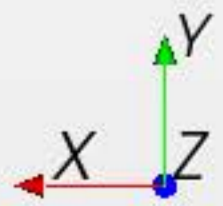

Volume Fraction of Sand

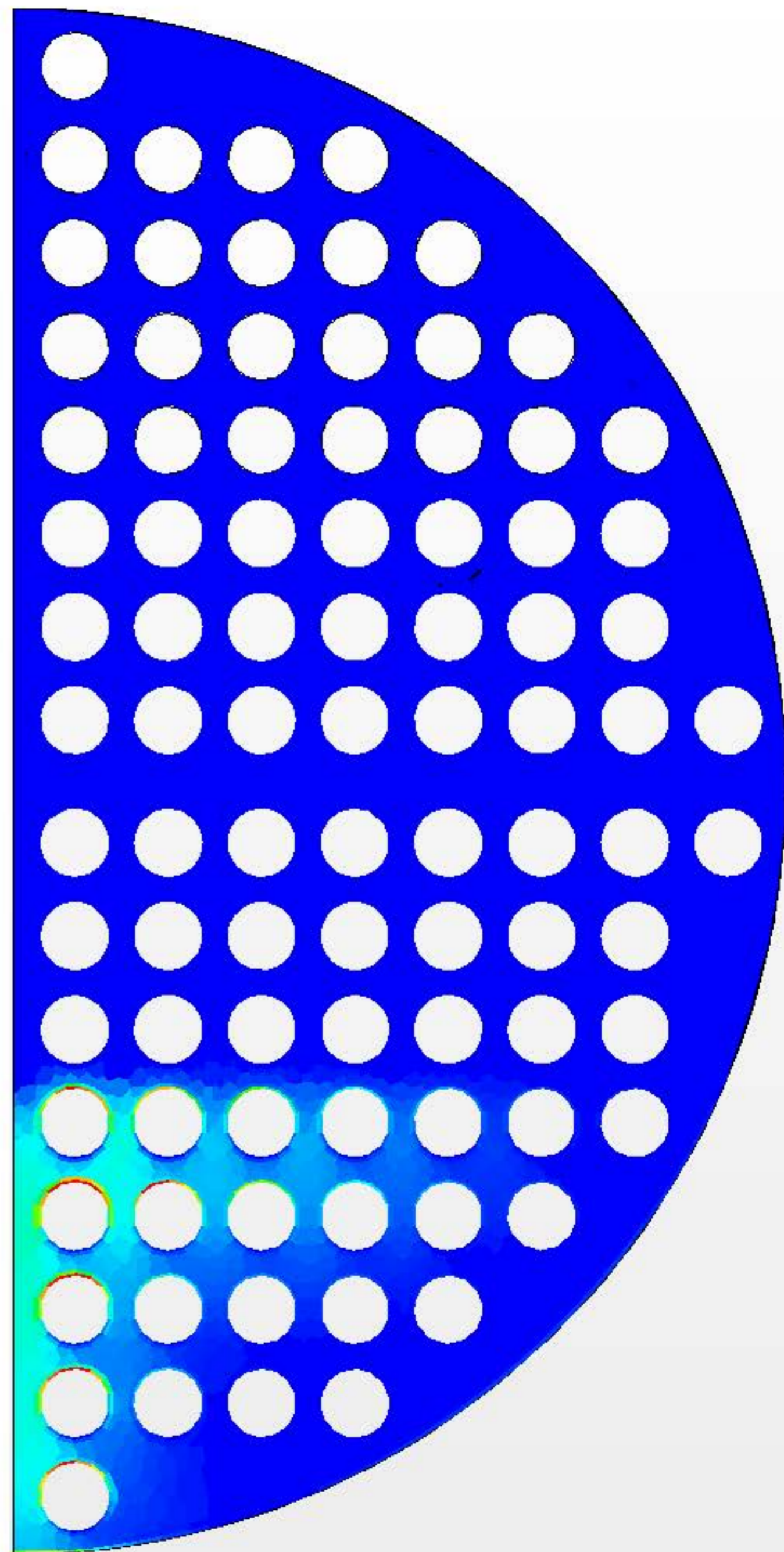
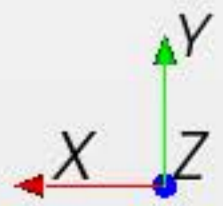
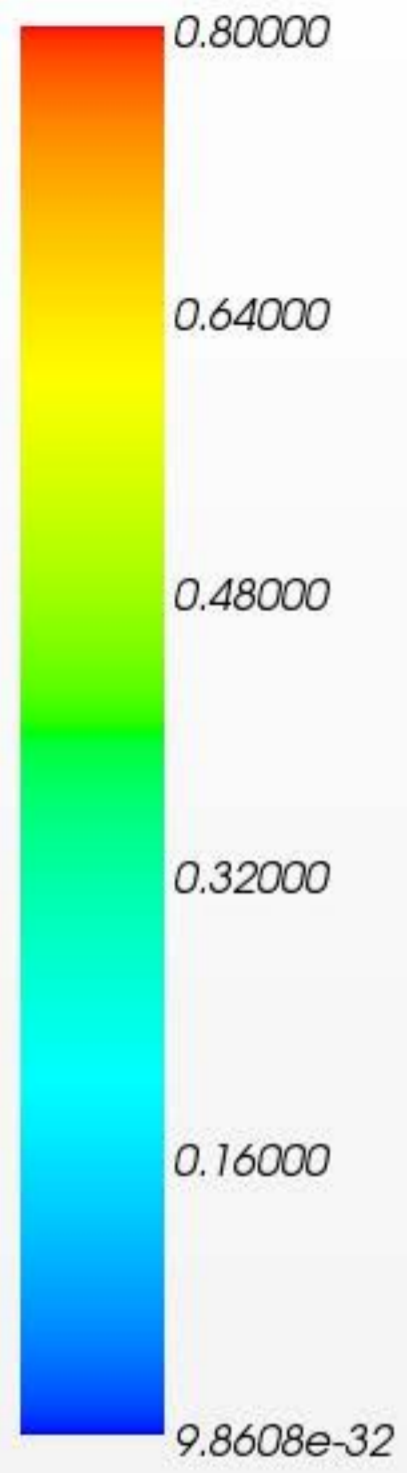

Volume Fraction of

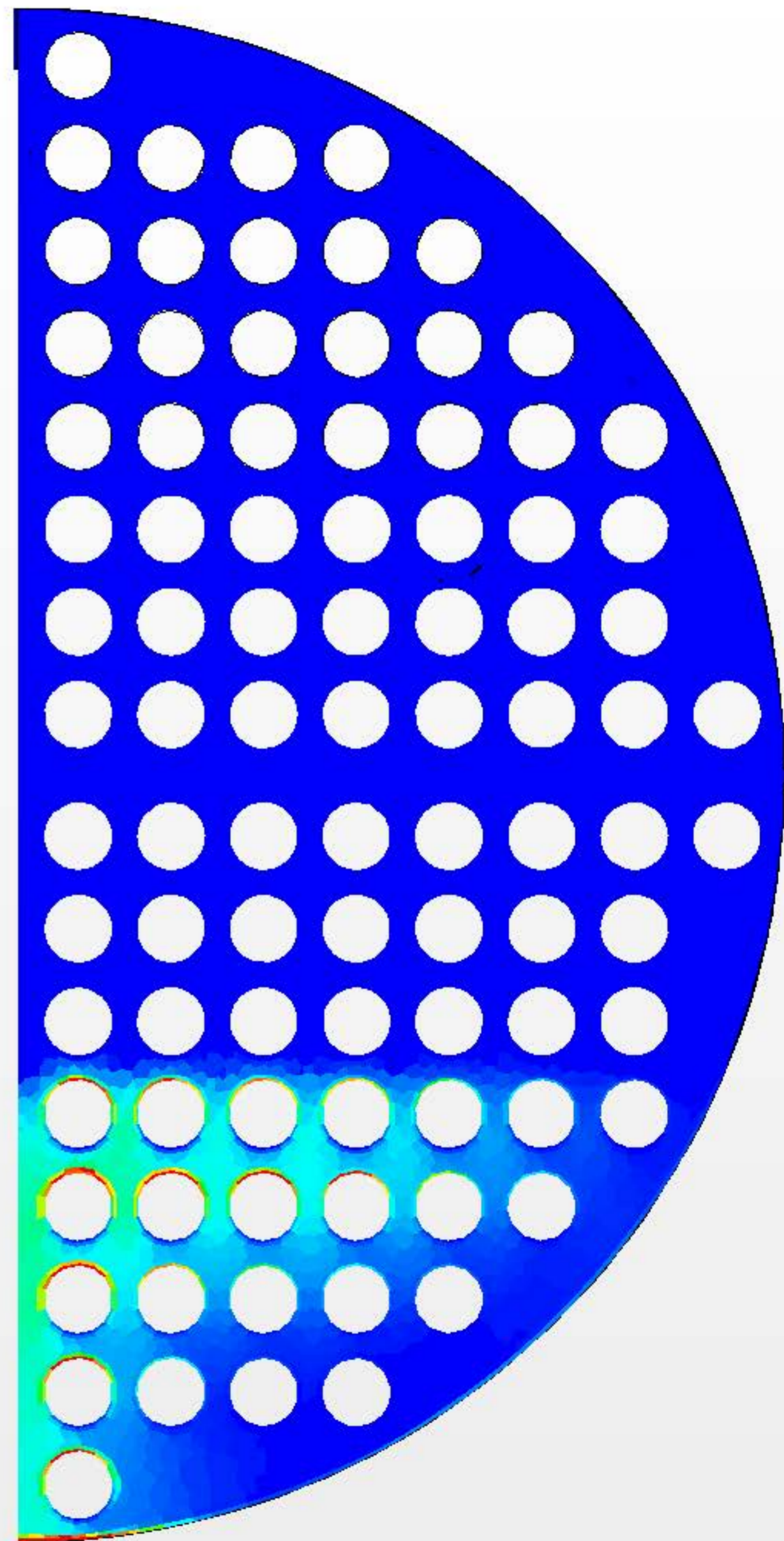
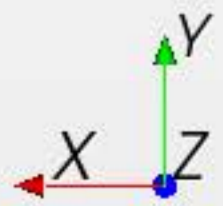

Volume Fraction of Sand

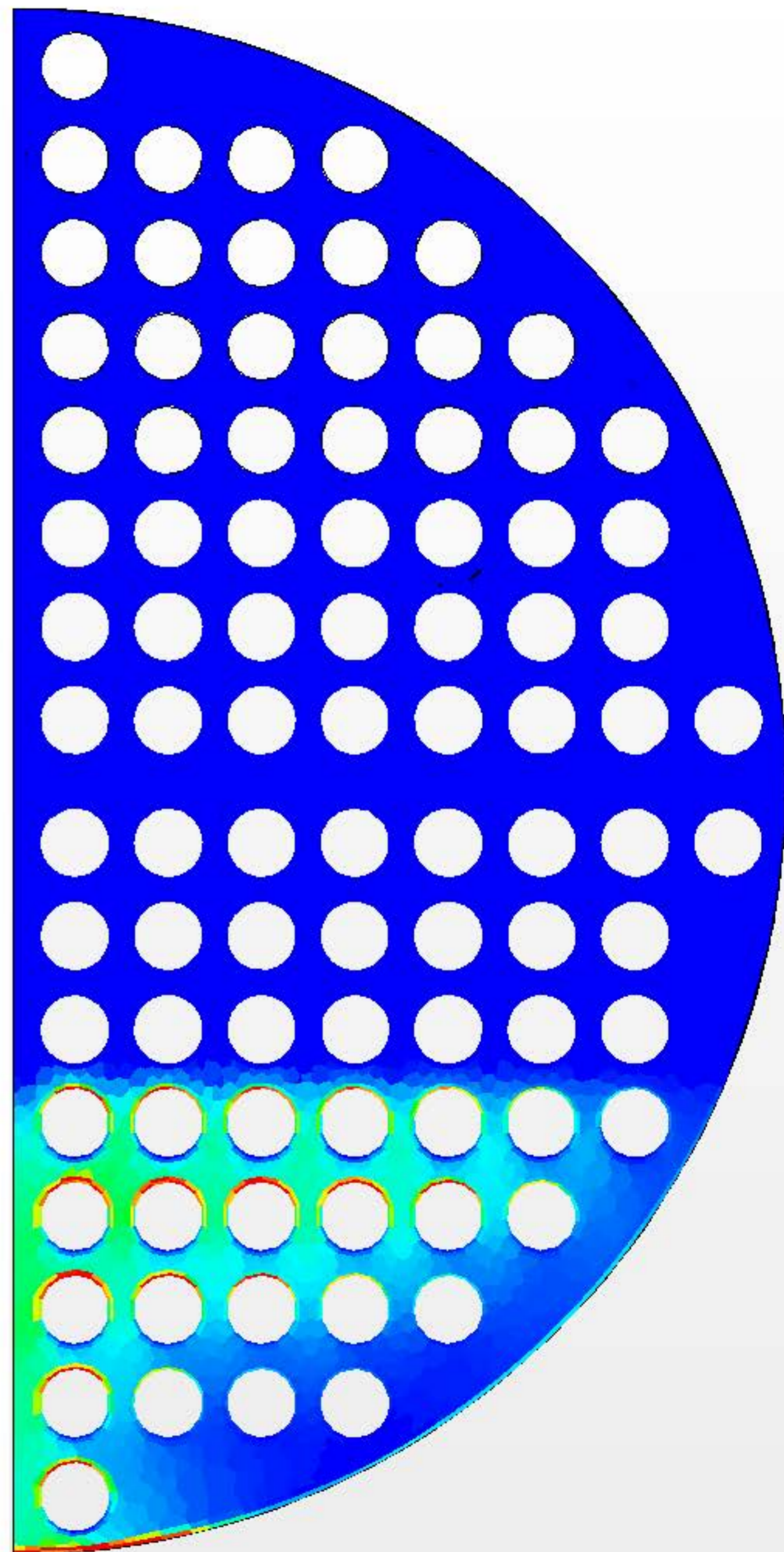
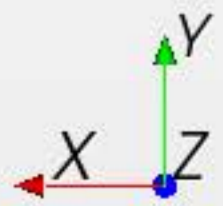

Volume Fraction of Sand

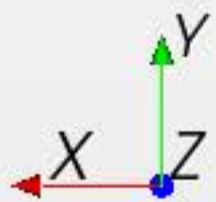
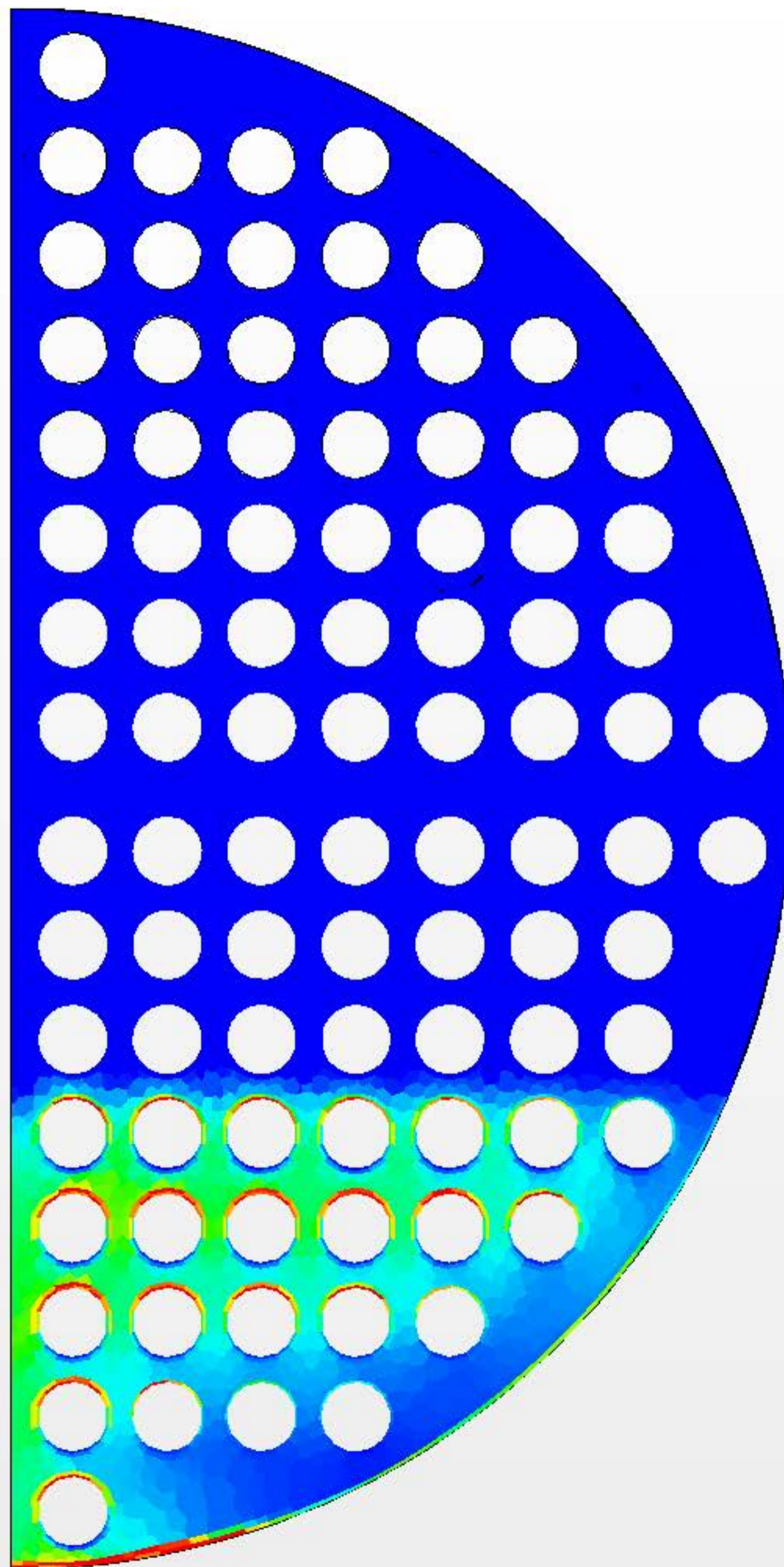

Volume Fraction of Sand

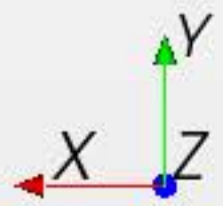
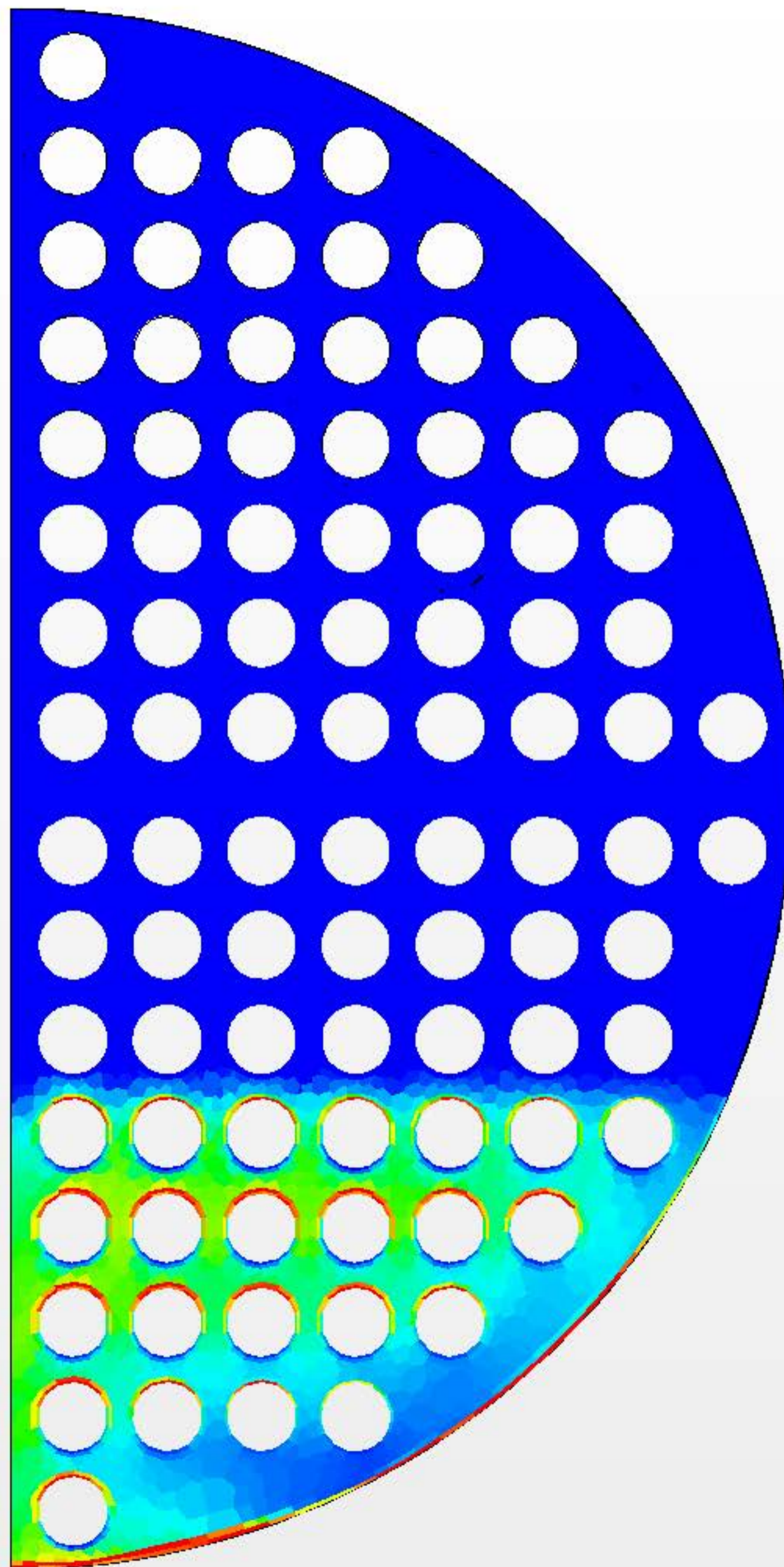

Volume Fraction of Sand

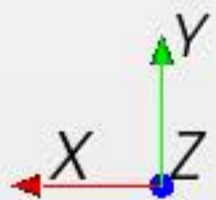
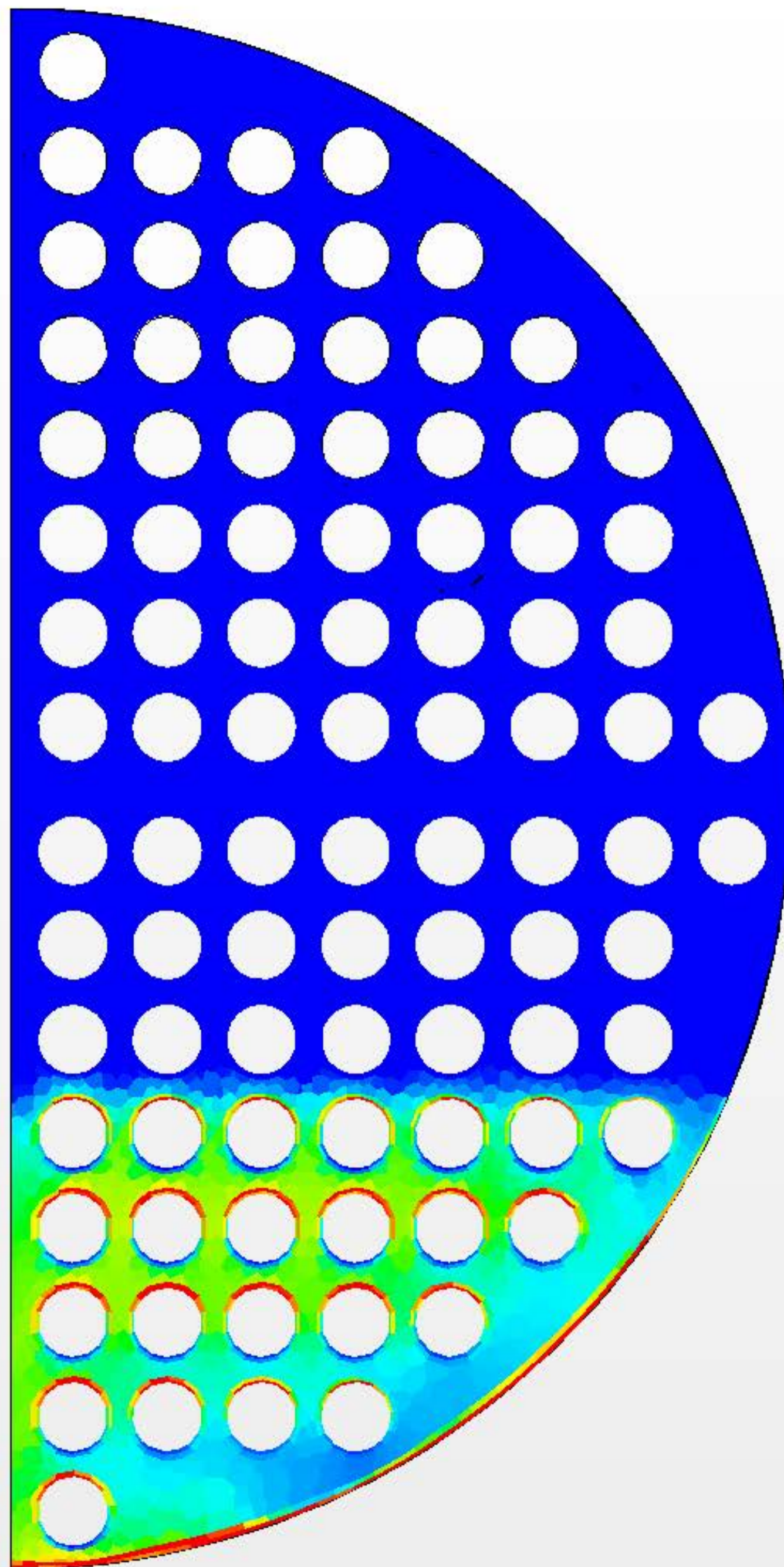
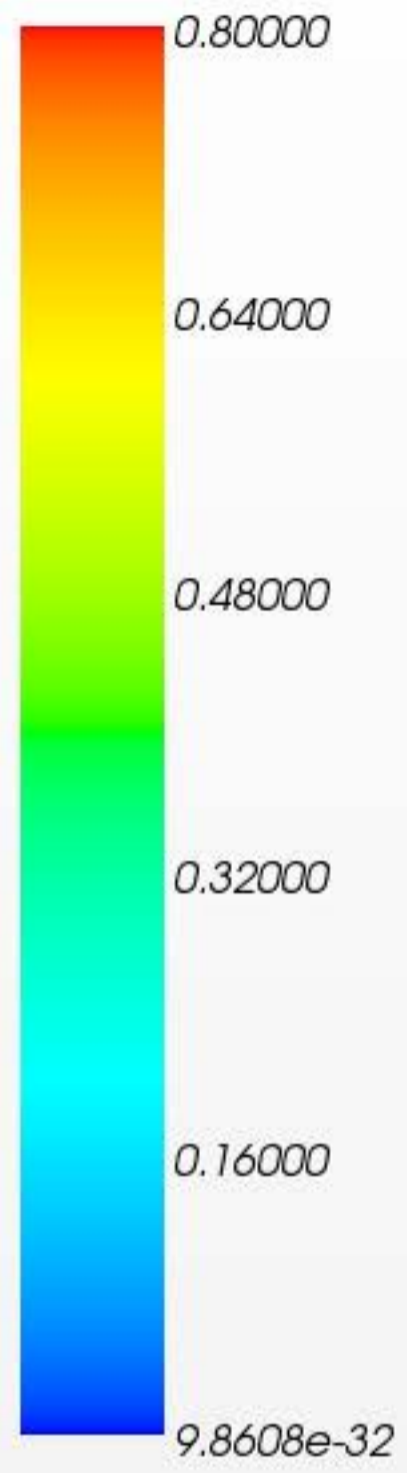

Volume Fraction of Sand

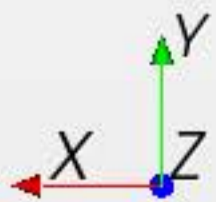
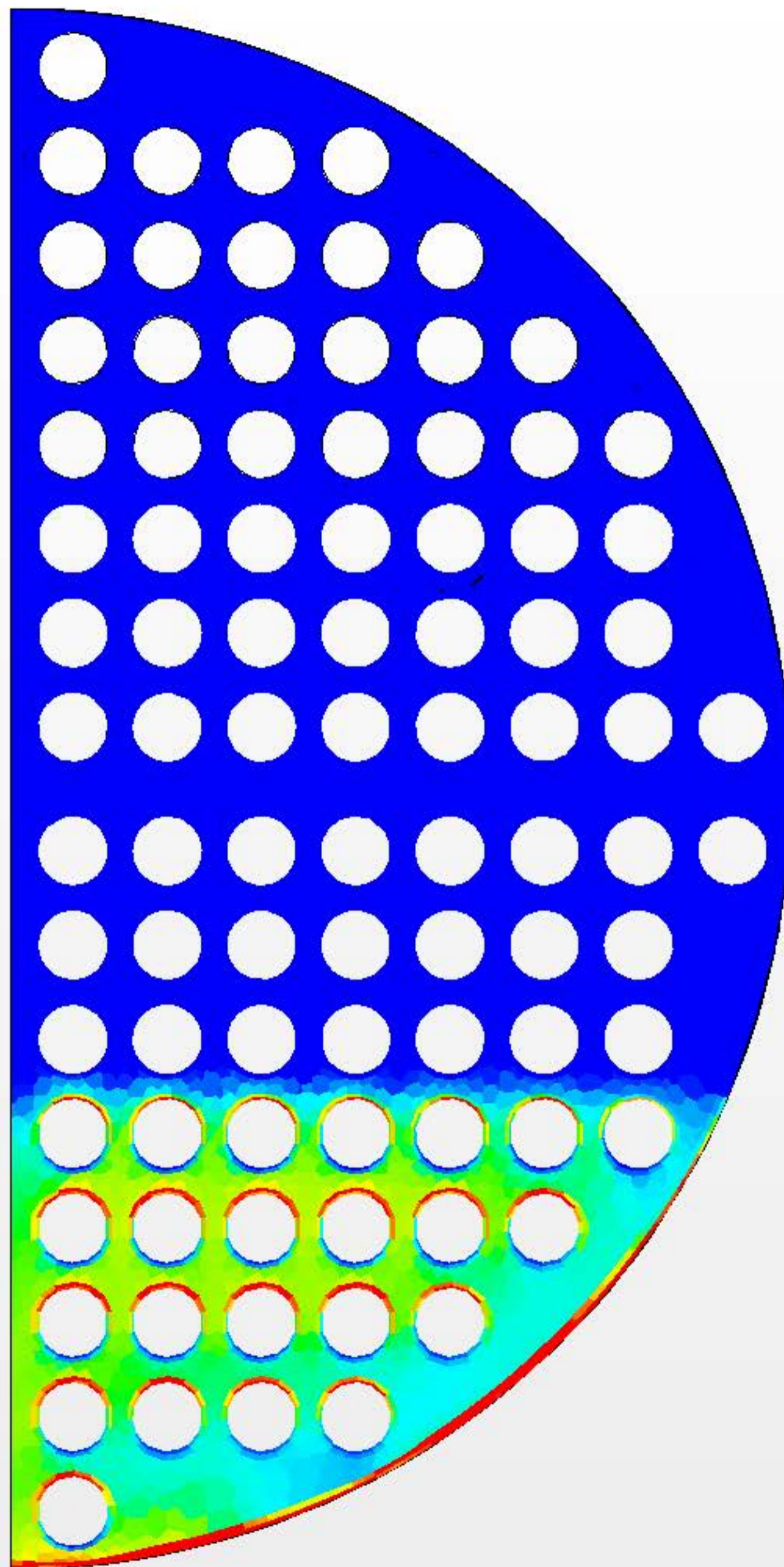

Volume Fraction of Sand

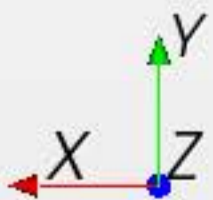
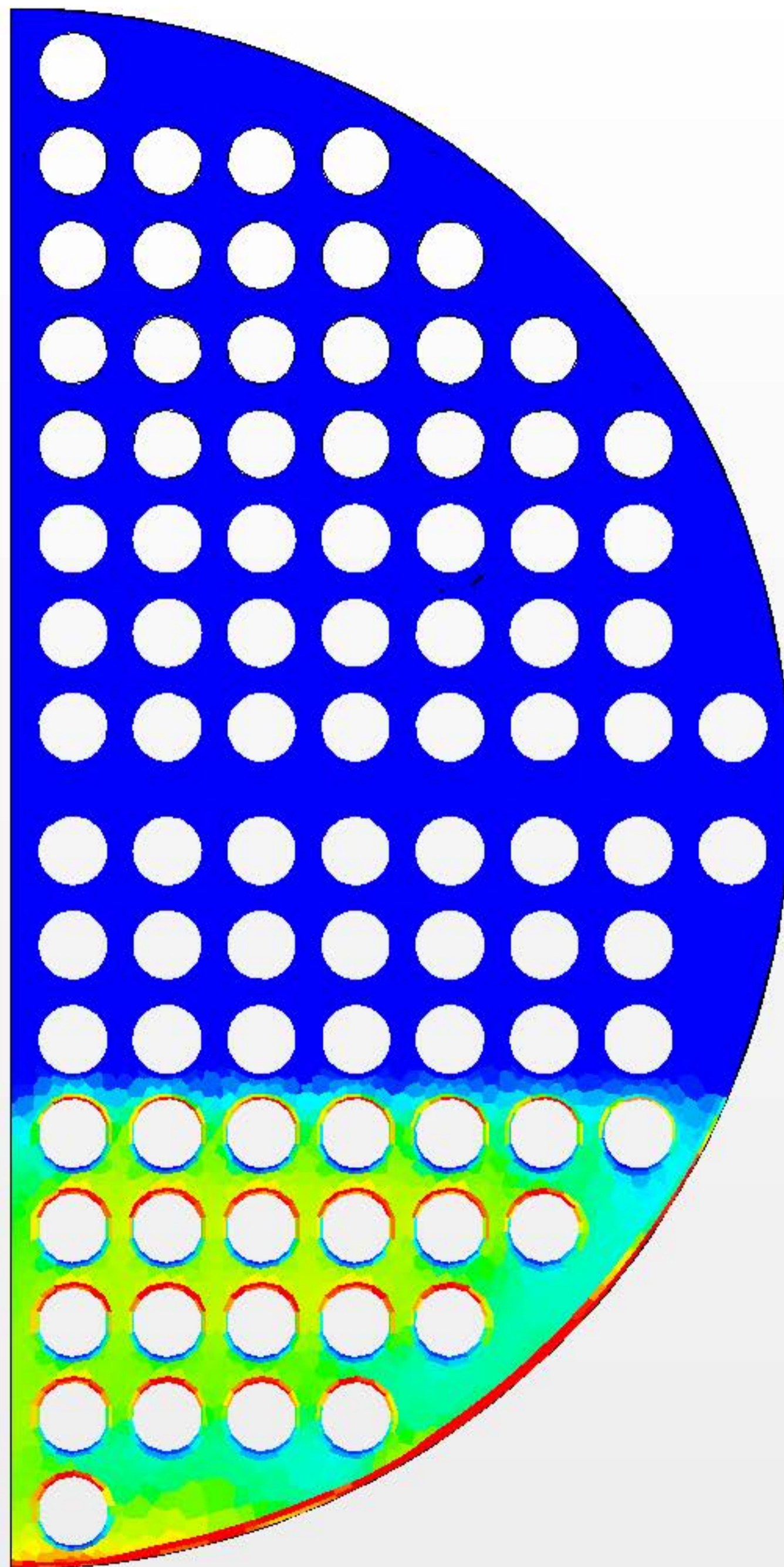

Volume Fraction of Sand

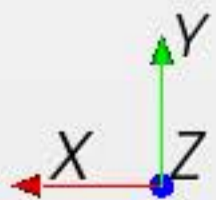
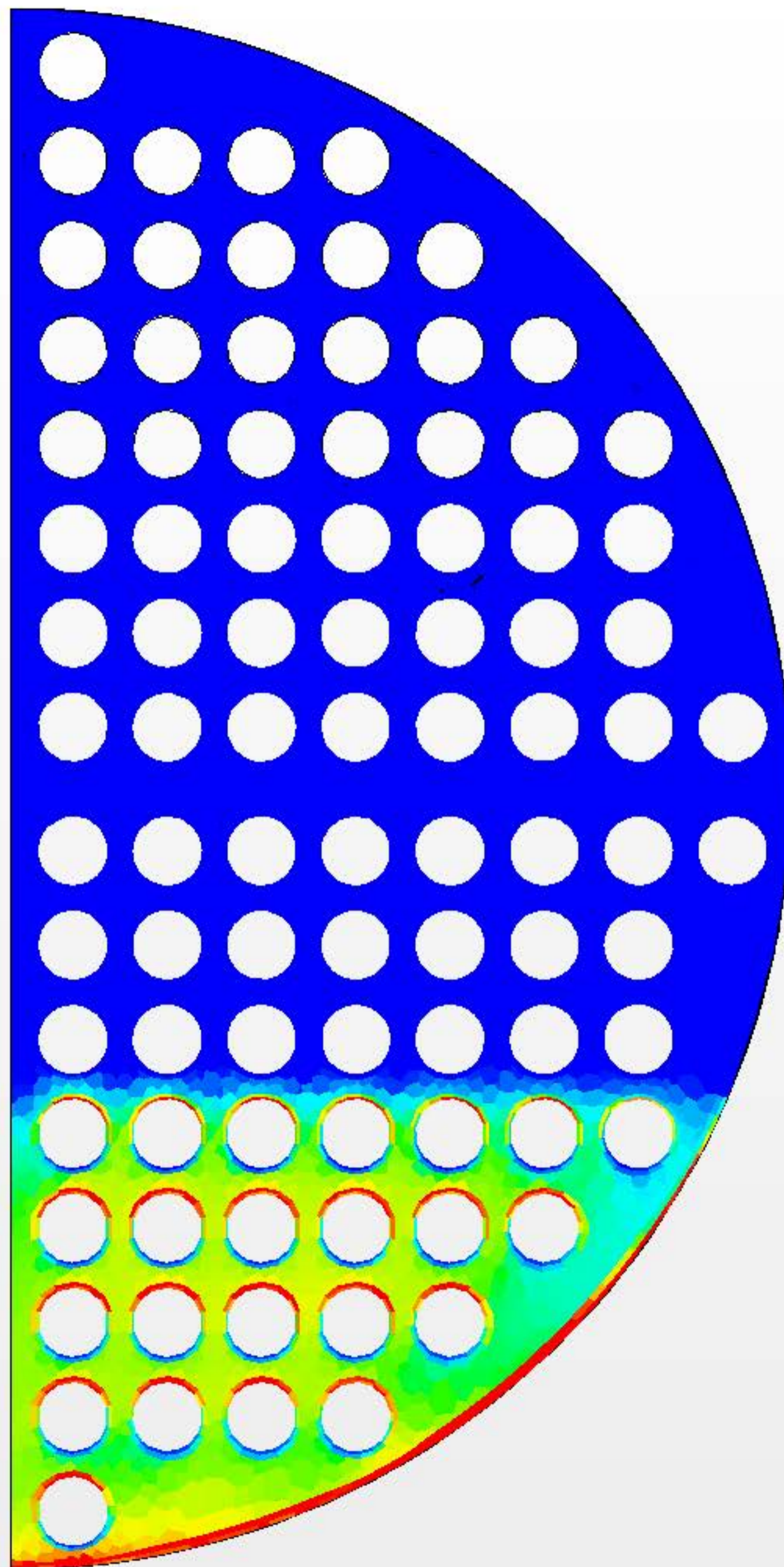

Volume Fraction of Sand

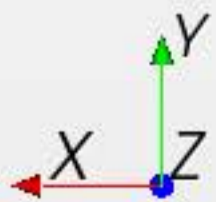
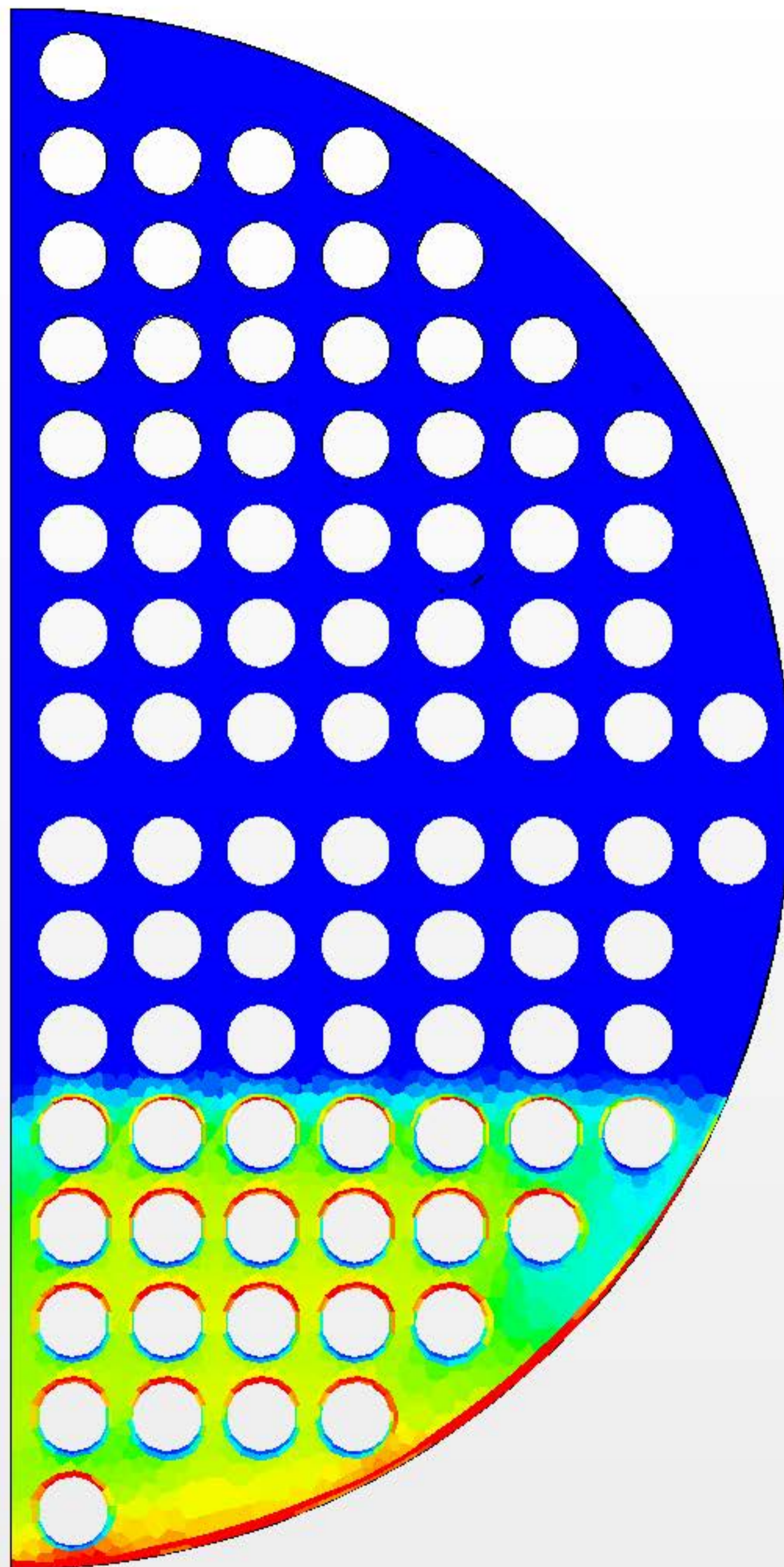

Volume Fraction of Sand

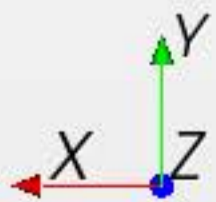
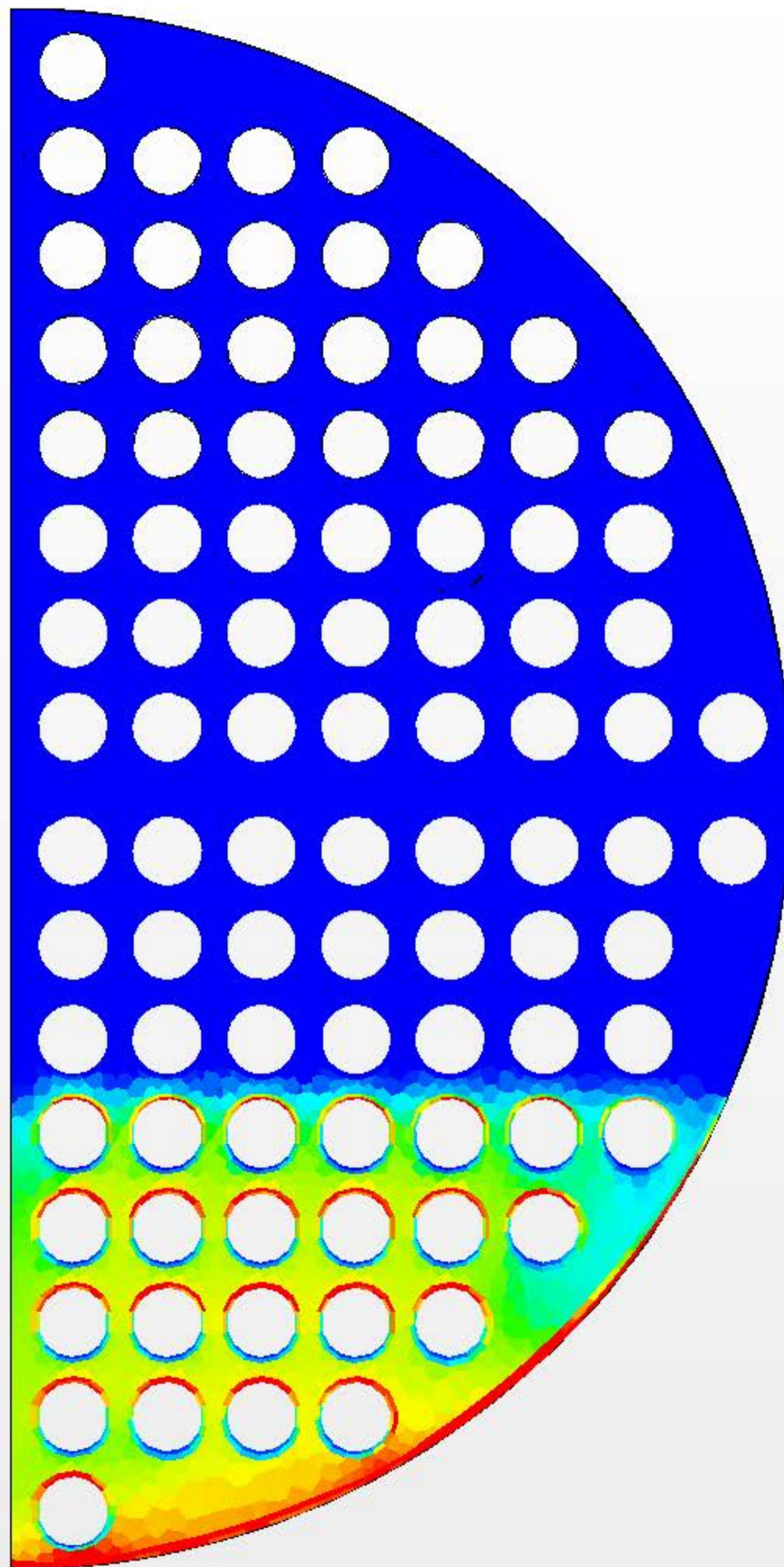
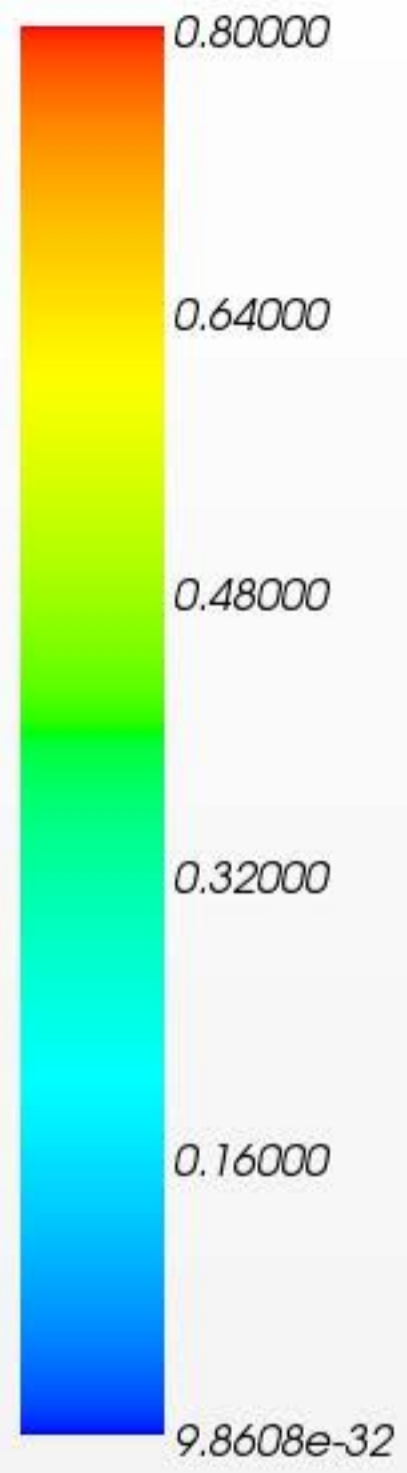

Volume Fraction of Sand

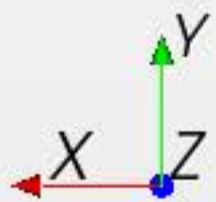
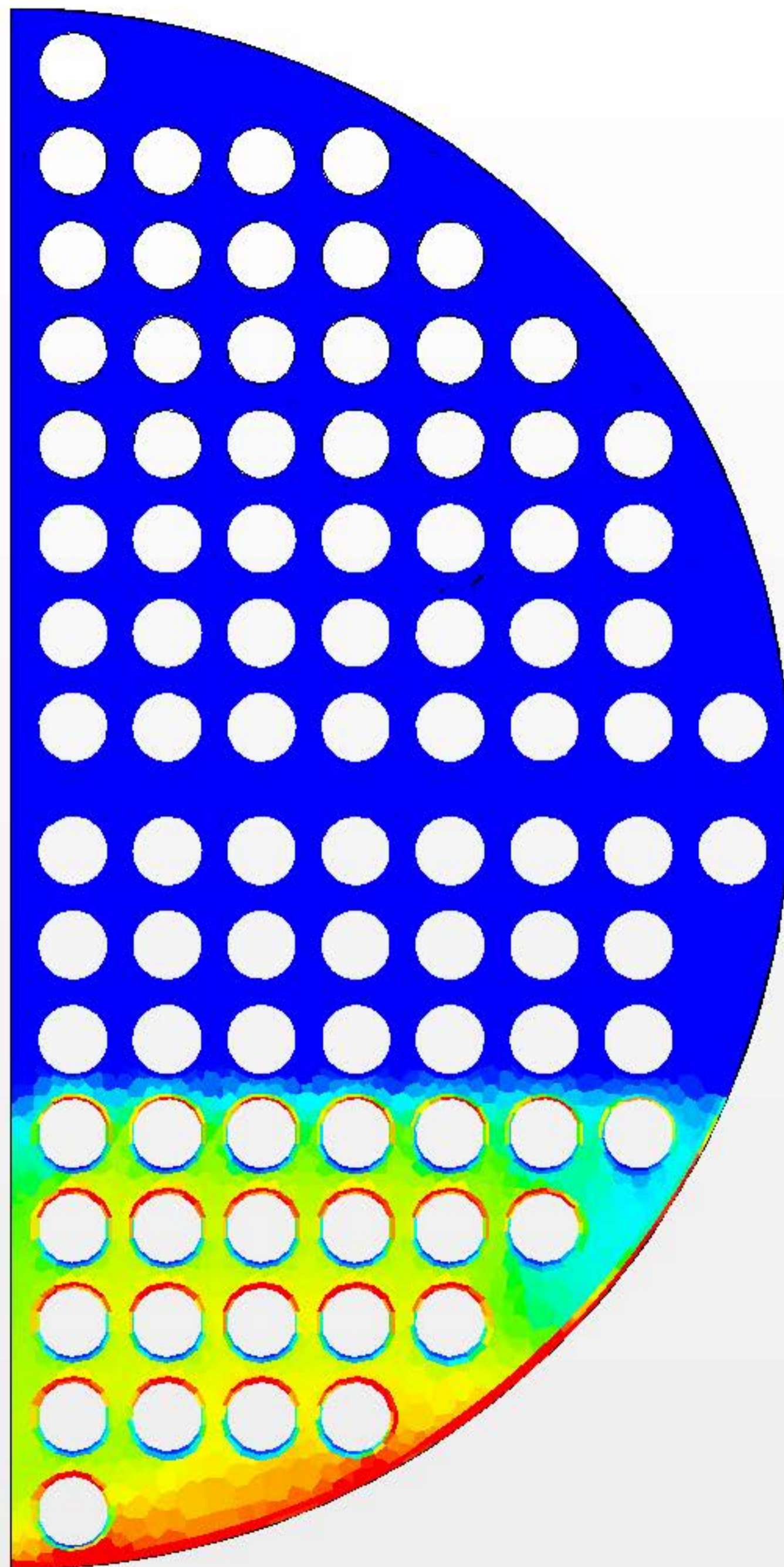

Volume Fraction of Sand

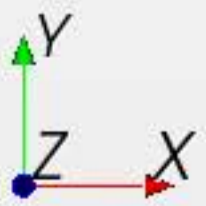
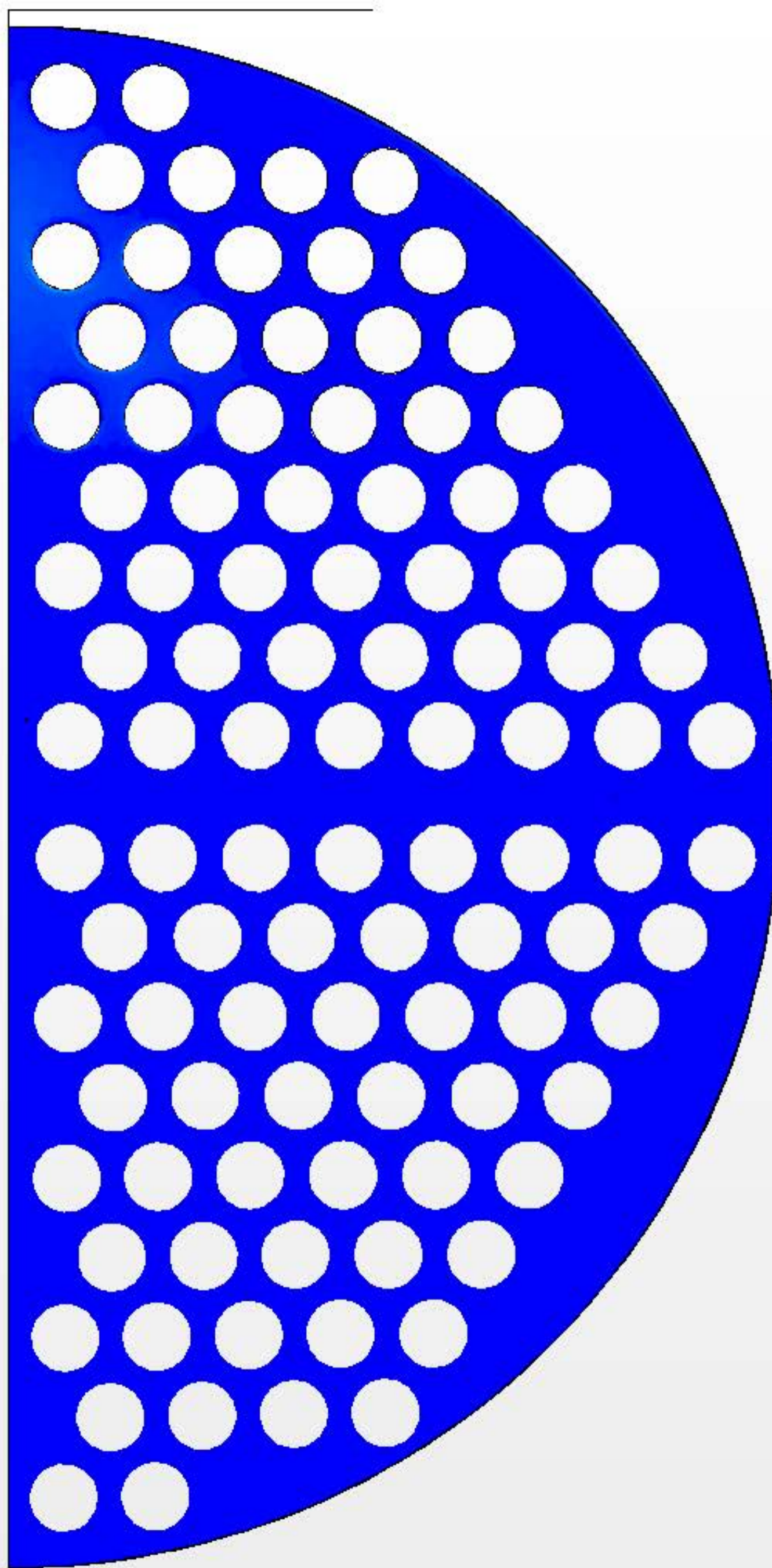

Volume Fraction of Sand

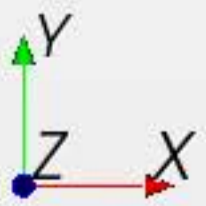
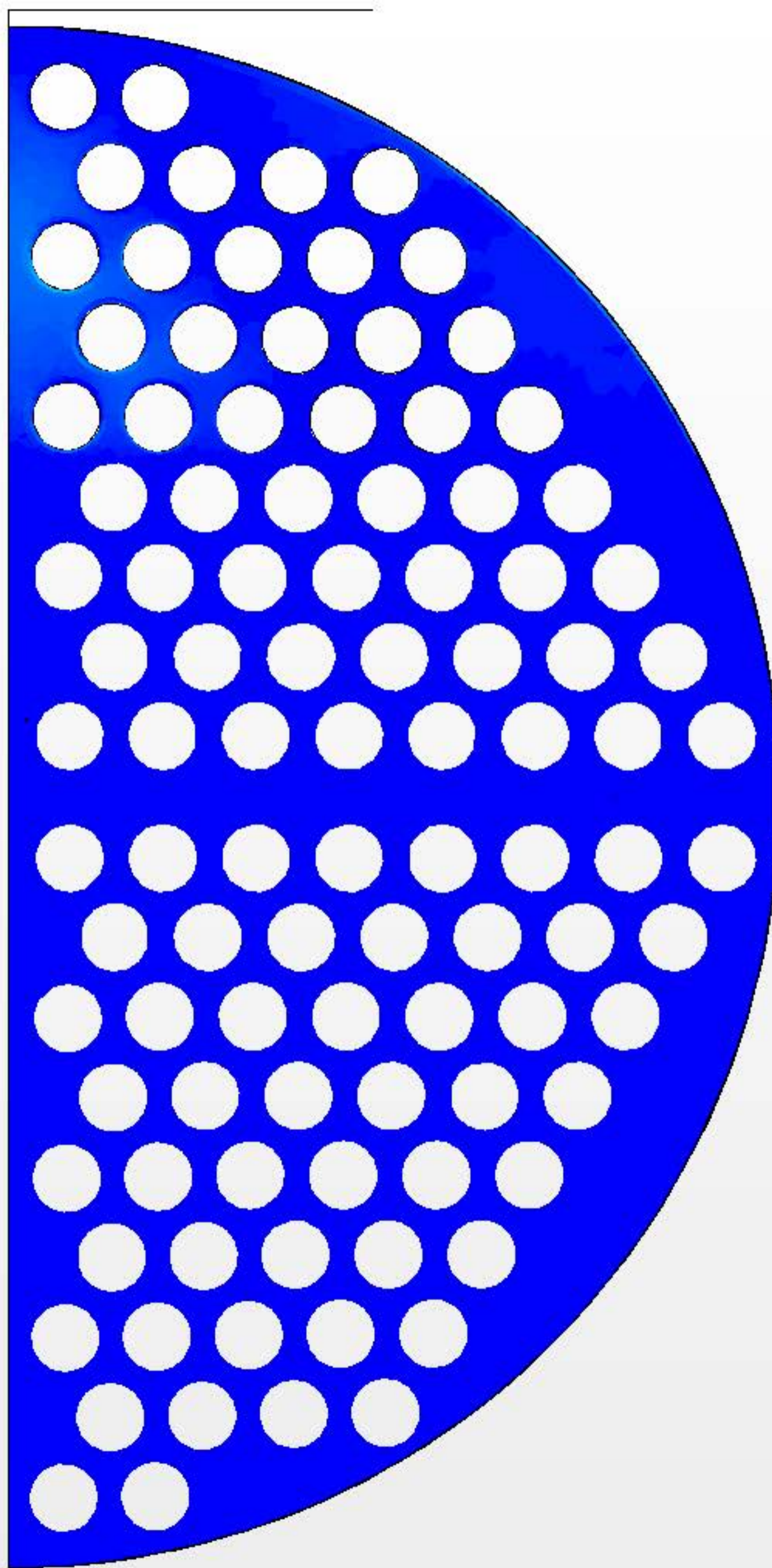

Volume Fraction of Sand

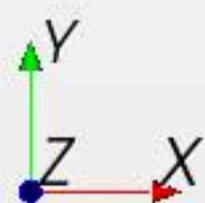
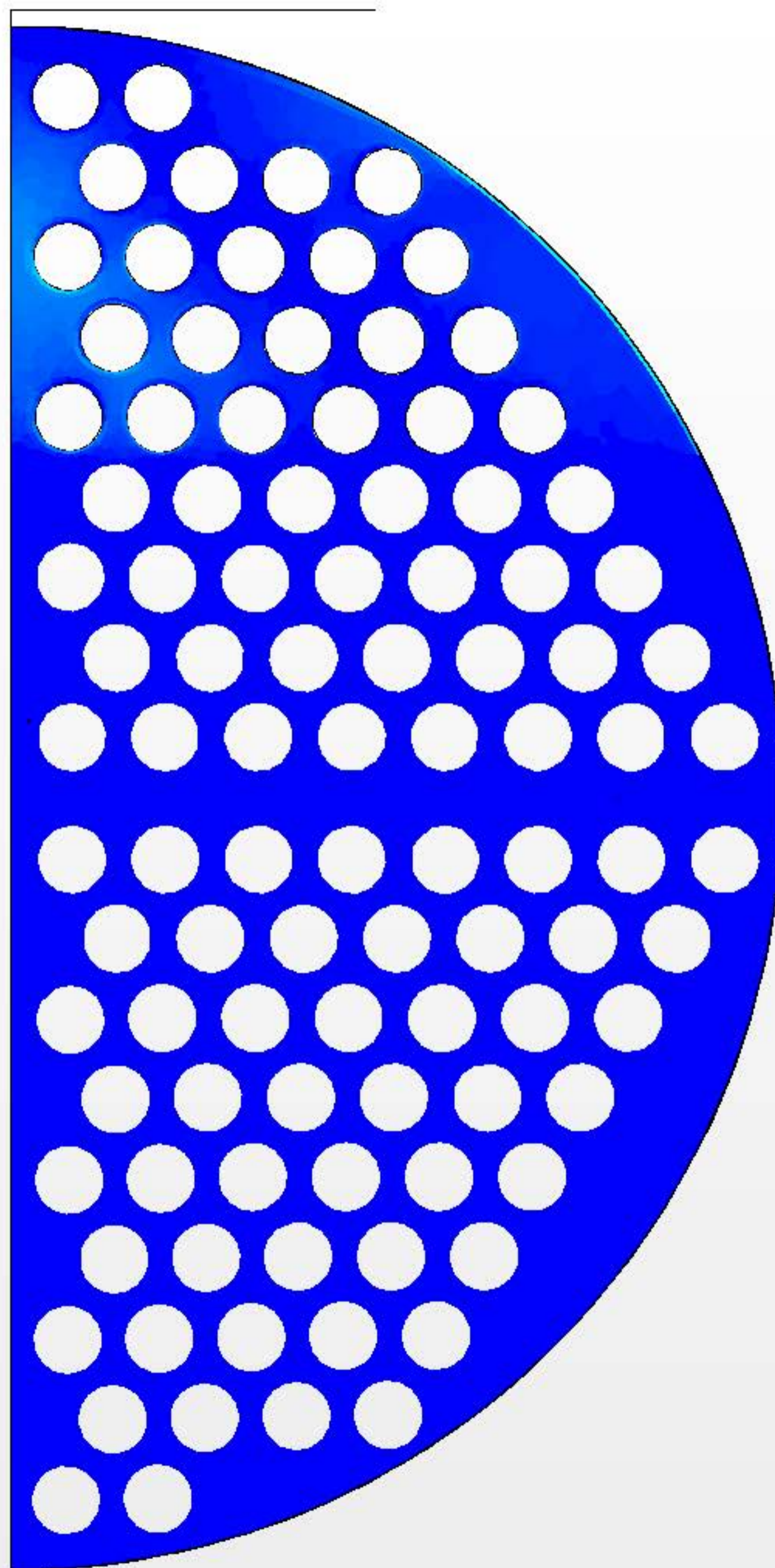

Volume Fraction of Sand

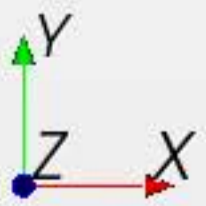
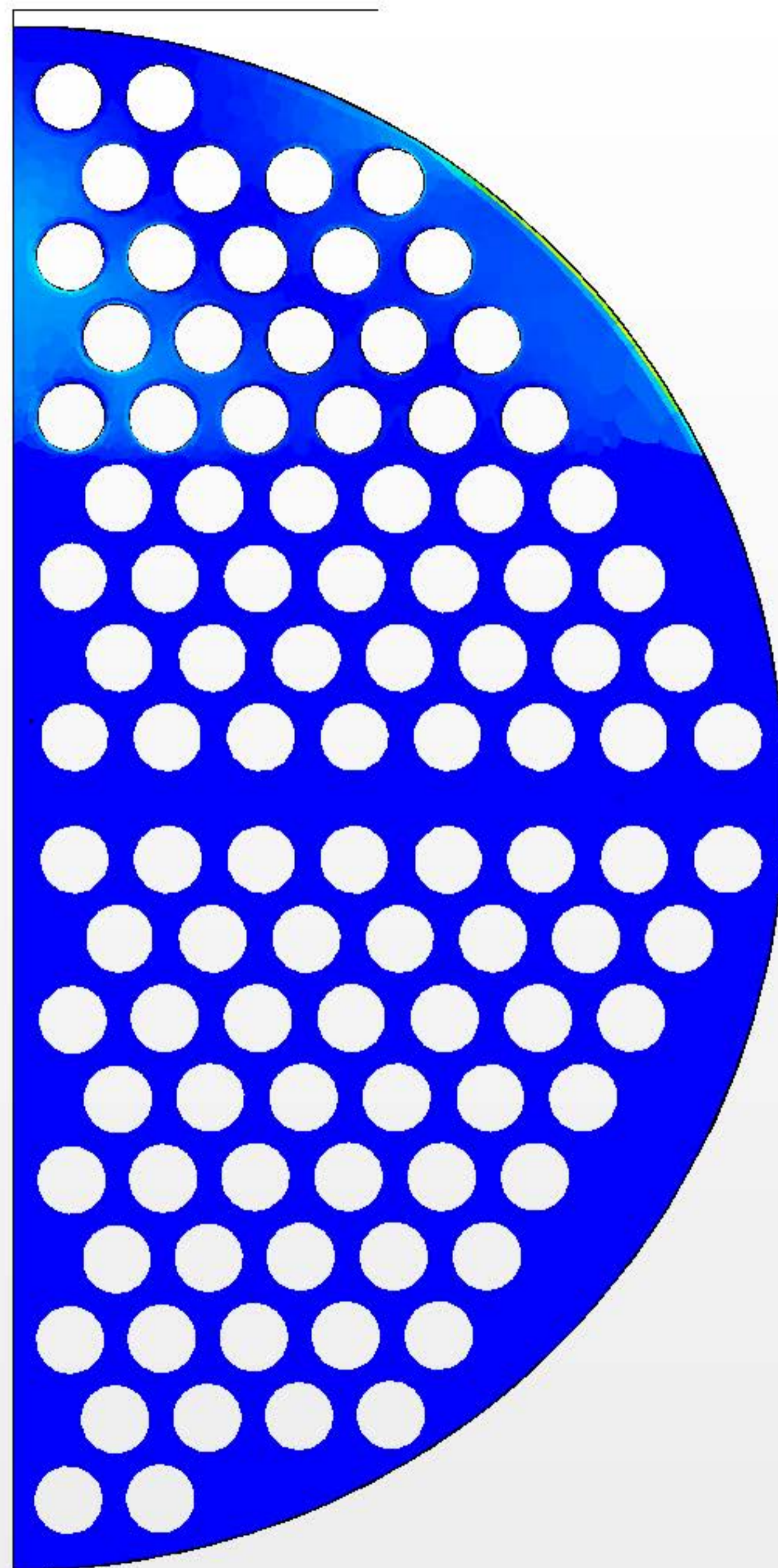

Volume Fraction of Sand

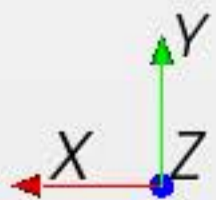
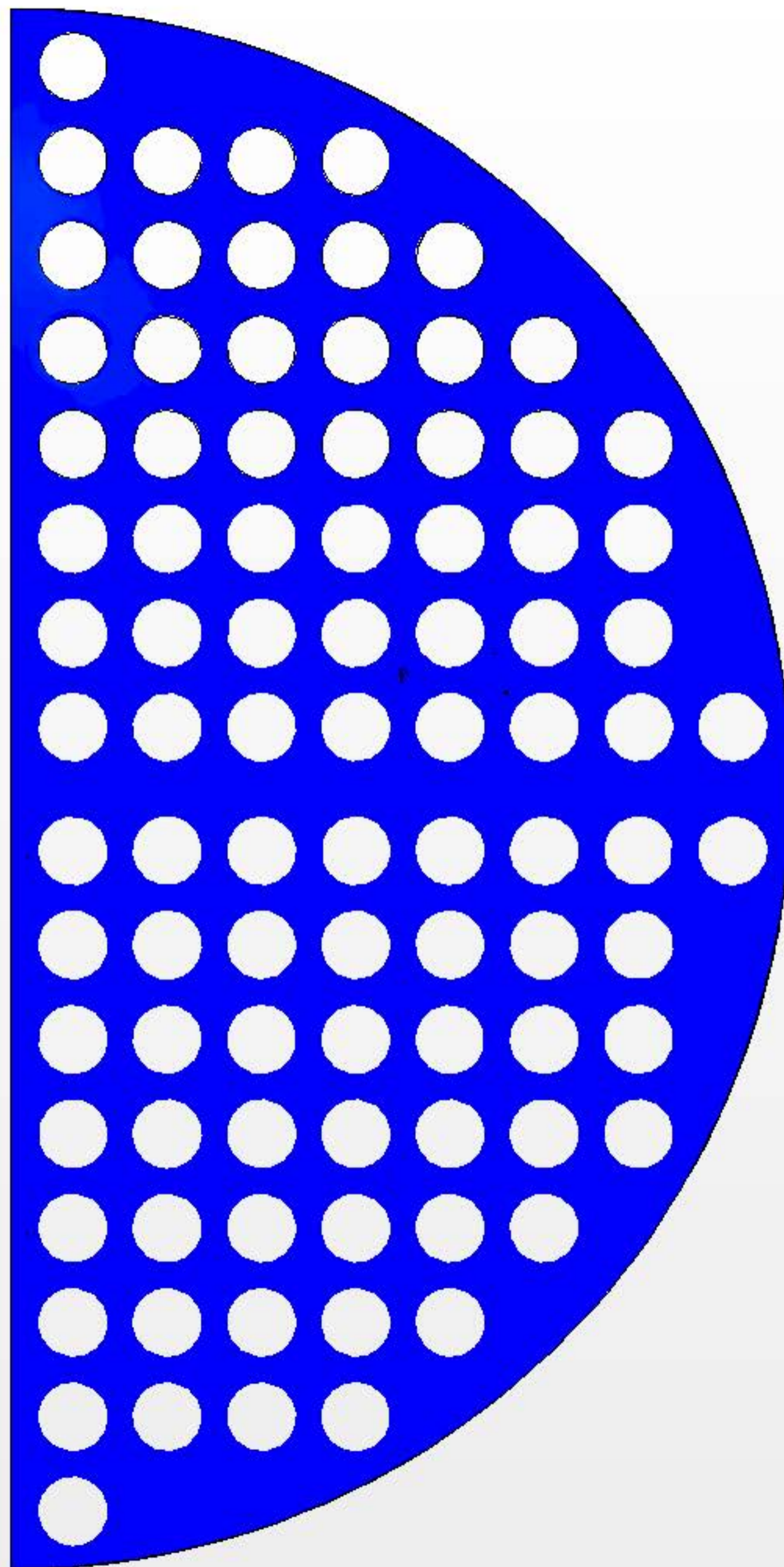

Volume Fraction of Sand

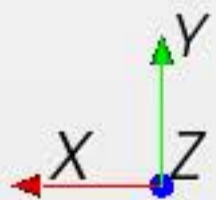
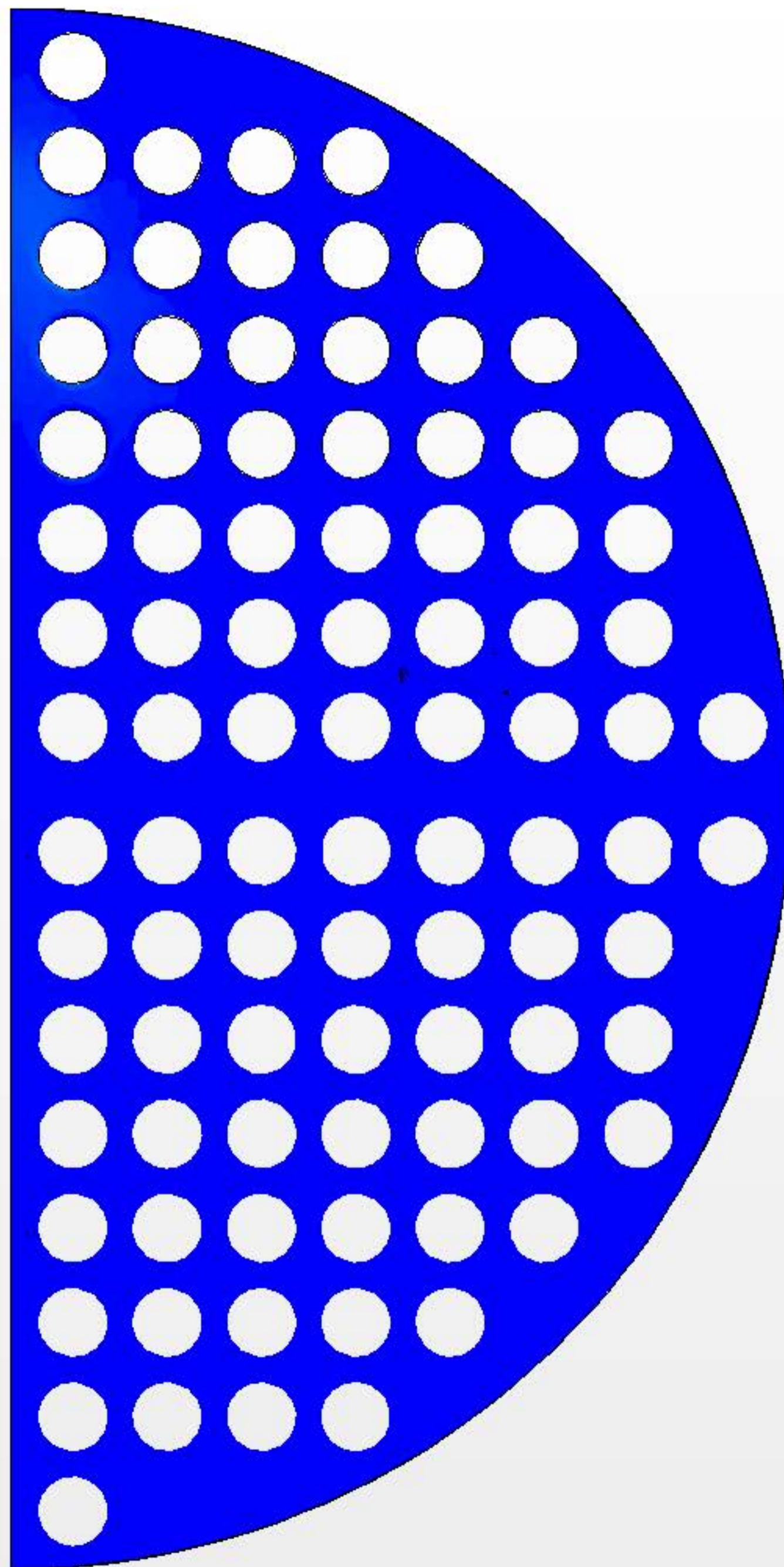

Volume Fraction of Sand

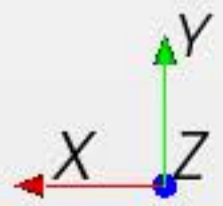
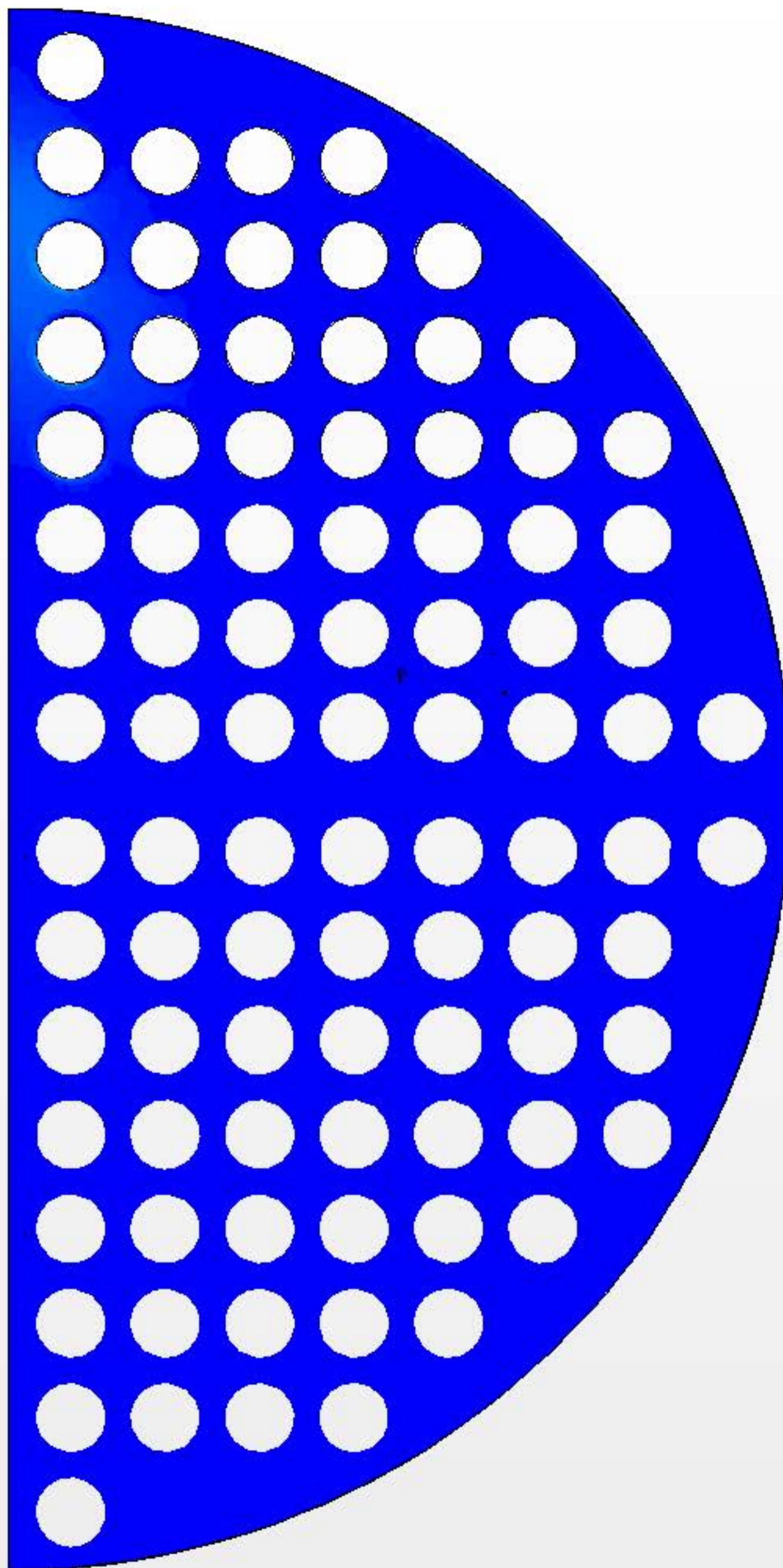

Volume Fraction of Sand

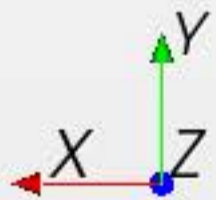
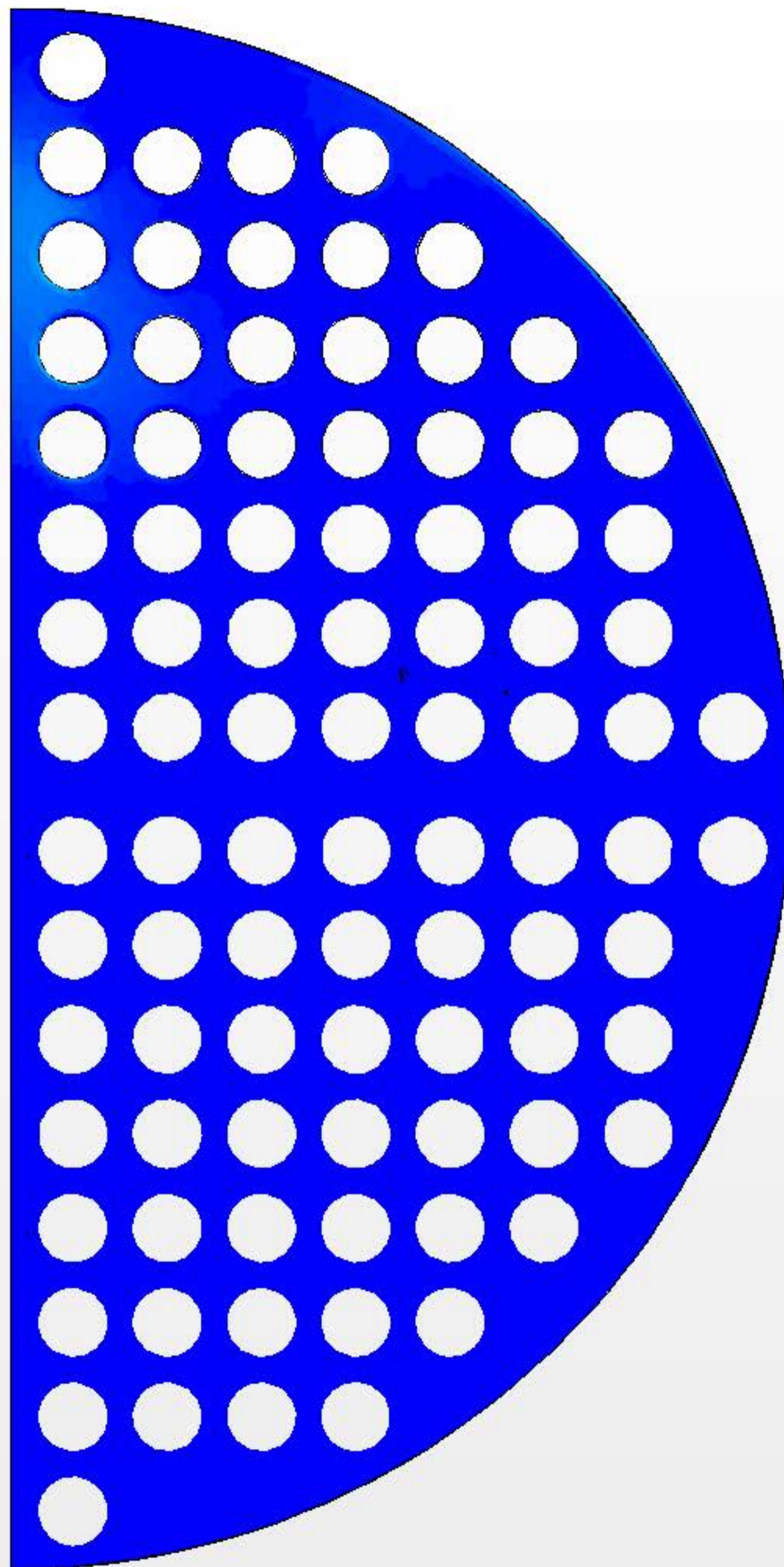

Volume Fraction of Sand

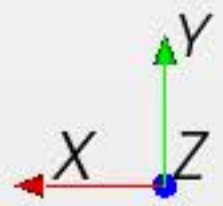
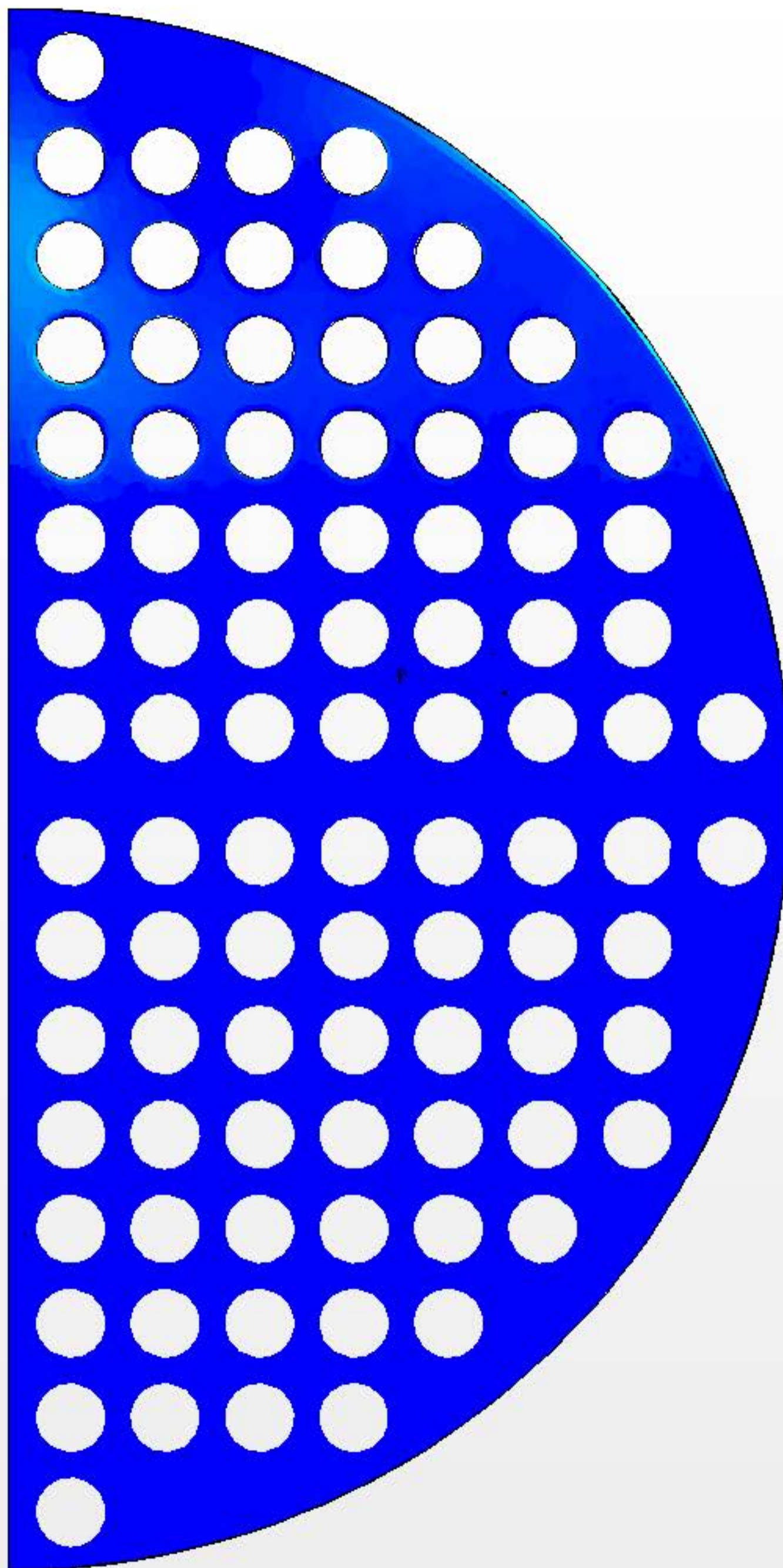

Volume Fraction of Sand

