

Interactive data mapping for industrial energy management

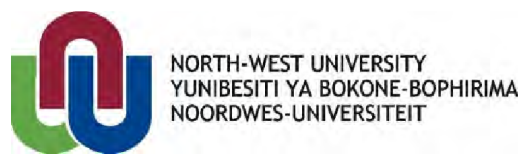

Oswald van Ginkel

20549636

Dissertation submitted in fulfilment of the requirements for the degree
Master of Engineering in Computer and Electronic Engineering
at the Potchefstroom campus of the North-West University

Supervisor: Dr. R. Pelzer

CRCED

November 2012

Keywords

energy, management, system, interactive, data, graph, DAG, PHP, web, industrial

Abstract

Data maps serve the purpose of visually representing information. They are especially useful for allowing people to grasp complex data structures. An interactive data map adds the functionality of people and systems being able to interact with the data through the use of the data map. This interaction may include navigation through parts of data structures or physically manipulating the underlying data.

In this study the feasibility of utilising an interactive data map implemented for the purpose of energy management in industries, such as gold mining and cement manufacturing, is taken under consideration. The interactive data map forms part of a complete energy management system that entails automated data capturing, control systems data aggregation, automated reporting and online interactive data presentation.

A software component, which is developed for the purpose of illustrating the use of such a data map, will serve as the main line of discussion. Various requirements from the current state of affairs are identified in the literature study. These are utilised as the basis of the specifications against which the interactive data map, as an efficient software tool for control, communication and policy compliance, is validated and verified.

Opsomming (Afrikaans)

Datakaarte vertoon inligting visueel. Hierdie kaarte is nuttig in die sin dat hul mense bemagtig om komplekse data strukture te kan verstaan. 'n Interaktiewe datakaart voeg die funksionaliteit, wat mense en stelsels toelaat om met die data deur middel van die datakaart in interaksie te tree, by. Hierdie interaksie mag navigasie deur gedeeltes van die data strukture of die fisiese manipulasie van die onderliggende data insluit.

In hierdie studie word die lewensvatbaarheid van die gebruik van 'n interaktiewe datakaart wat toegepas word vir energiebestuur in die industrie, soos by die die myn van goud en vervaardiging van sement, ondersoek. Die interaktiewe datakaart vorm deel van 'n alles omvattende energie bestuursstelsel wat data op geoutomatiseerde wyse onttrek, beheersisteme se data versamel, verslae outomaties uitstuur en ook data aanlyn visueel voorstel.

'n Sagteware komponent, wat ontwikkel word vir die doel om die gebruik van so 'n data kaart te illustreer sal dien as die hooflyn van gesprekvoering. Verskeie vereistes vanuit die huidige stand van sake word in die literatuurstudie geïdentifiseer. Hierdie vereistes word gebruik as die grondslag van die spesifikasies waarteen die datakaart, as 'n effektiewe sagteware nutsmiddel vir beherende bestuur, kommunikasie en beleidsnakoming, gevalideer en geverifieer word.

Acknowledgements

I am grateful for my inspiring family and friends who always have the most appropriate advice at the critical moments. I am grateful for the guidance and design inputs received from my supervisor and excellent colleagues at the Centre for Continued Engineering Development in Pretoria. I would also like to acknowledge the access to data, development experience gained and necessary funding received from TEMM International (Pty) Ltd that allowed the phases of this endeavour to succeed fluently.

Table of Contents

	Page
Abstract	I
Opsomming (Afrikaans)	II
Acknowledgements	III
Table of Contents	IV
List of Tables	VII
List of Figures	VIII
List of Terms and Abbreviations	X
1 Introduction	1
1.1 Background	1
1.2 Research question	4
1.3 Research goals and chapter overview	4
2 Literature study	13
2.1 Chapter introduction	13
2.2 Uncertainty in semeiotics	13
2.3 Software techniques in data mapping	15
2.4 Application of data maps and data mining strategies	17
2.5 Energy management through intelligent control	19
2.6 Data mapping that includes GIS	20
2.7 Management and personnel systems	21
2.8 Addressing the temporal nature of data	22
2.9 The ability of data systems to adapt	22
2.10 Aspects of management control	23
2.11 Focusing on role instead of rank in management	24
2.12 The evolution of control	26
2.13 Conclusive remarks	27

3	Design analysis	28
3.1	Chapter introduction	28
3.2	Specification statement	28
3.3	Functional breakdown	31
3.4	User perspective	32
3.5	Administrative perspective	34
3.6	Code management and maintenance perspective	34
3.7	Conclusive remarks	37
4	Detailed design	38
4.1	Chapter introduction	38
4.2	Logical interaction	38
4.3	Object allocation	39
4.4	User interface	44
4.5	Conclusive remarks	46
5	Implementation	47
5.1	Chapter introduction	47
5.2	Environment	47
5.3	Maintenance and support	52
5.4	Conclusive remarks	53
6	Results	54
6.1	Chapter introduction	54
6.2	Client case study	54
6.3	Preliminary results	61
6.4	Processed results	63
6.5	Verification and validation	65
6.6	Conclusive remarks	70
7	Interpretation and Conclusion	71
7.1	Proposed enhancements	71
7.2	Additional applications	72
7.3	Conclusion	72

Bibliography 74
Addendum A i

List of Tables

1.1	Overview of literature	9
2.1	Types of control	23
2.2	Random coherent and correlated behaviour	25
5.1	Minimum requirements	52
6.1	AfriSam Ulco Process Line - DSM Summary	55
6.2	Evander OAN - DSM Summary	57
6.3	Kusasaletu CA - DSM Summary	59
6.4	Logins - Analysis per system user	61
6.5	Logins - Analysis per purpose	62
6.6	Verification of summarised specifications	65
6.7	Validation of specifications	67

List of Figures

1.1	Eskom's available generation	2
2.1	Graph examples	16
2.2	Visible complexity at different scales	25
3.1	The data map system as interface	31
3.2	Client side basic manager layout	32
3.3	User interaction sequence for transfer operation	35
4.1	Artifact interaction	39
4.2	UML diagram for data map's database tables	40
4.3	Interactive data map user interface	44
4.4	Interactive data map used to indicate requirements for ISO 50001	45
4.5	Interactive data map administrative interface	45
5.1	Cement industry power profile and baseline	48
5.2	Cement industry raw data	50
5.3	Projects' maintenance report process	51
6.1	AfriSam Ulco Process Line - DSM Impact	56
6.2	AfriSam Ulco Process Line - DSM Cost Savings	56
6.3	Evander OAN - DSM Impact	58
6.4	Evander OAN - DSM Cost Savings	58
6.5	Kusasaletu CA - DSM Impact	59
6.6	Kusasaletu CA - DSM Cost Savings	60
6.7	Logins - Analysis per system user	63
6.8	Logins - Analysis per purpose	64
A.1	User interface frame 1	i

A.2	User interface frame 2	ii
A.3	User interface frame 3	ii
A.4	User interface frame 4	iii
A.5	User interface frame 5	iv
A.6	User interface frame 6	v
A.7	User interface frame 7	vi
A.8	User interface frame 8	vii
A.9	User interface frame 9	viii
A.10	User interface frame 10	viii
A.11	User interface frame 11	ix
A.12	User interface frame 12	x
A.13	User interface frame 13	x
A.14	User interface frame 14	xi
A.15	User interface frame 15	xi
A.16	User interface frame 16	xii
A.17	User interface frame 17	xii
A.18	User interface frame 18	xiii
A.19	User interface frame 19	xiii
A.20	User interface frame 20	xiv
A.21	User interface frame 21	xv

List of Terms and Abbreviations

AES	Advanced Encryption Standard, 41
AGE	Applied General Equilibrium model, 23
Apache™	This is a web server service that can manage dynamically typed web server code such as PHP, 7
ASN.1	Abstract Syntax Notation One: Used by ISO, 74
Attribute inaccuracy	Misunderstanding in the data collected or even deliberate misinformation, 14
BMS	Building Management System - a computerised control system, 19
BoUML software package	This efficient universal modelling software was previously released as freeware by the French developer; Bruno Pagès; but it is commercially available from http://www.bouml.fr , 38
Bourne	To become a feasible idea: in the sense of a goal set for this purpose; bounded by the necessary scope and specifications, 8
Branching ratio	Amount of child nodes connected to a node; e.g. the number of individuals supervised by one manager, 25
CA	Cooling auxiliaries, 59
Carrying capacity	A method that aims at quantifying the number of individuals of a given species that a defined habitat can support indefinitely, 17

CGE	Computable General Equilibrium, 23
CIPEC	Canadian Industry Program for Energy Conservation, 74
Class	From programming jargon - a template for code objects, 40
Completeness	Comprehensive data and systematic ways of dealing with values, 14
Complex data structure	This refers to graph structures where certain nodes may need to be evaluated more than once to process all linked nodes, 8
Correlation analysis	An analysis that determines the existence of a statistical relation between two or more variables, 21
CSCW	Computer Supported Cooperative Work, 14
DAG	Directed acyclic graph, 16
DMP	Demand Market Participation, 42
DRASTIC	A principal component analysis method; predecessor to SINTACS, 20
DSM	Demand side management, 3
Ecological footprint approach	A method that focuses on the demand side by calculating the resource consumption of a population; expressed in biologically productive area with global average hectares as measurement unit, 17
EMS	Energy Management System, 19
Energy efficiency	Using less energy through efficient machinery and intelligent control, 4

EnMS	Energy Management Systems, 3
Enumerators	Persons or systems collecting data, 14
EPSM	Extended Power State Machine, 19
Ergonomics	The branch of engineering science in which biological science is used to study the relation between workers and their environments, 14
ESCo	Energy services company, 1
Eskom	Primary electricity utility company based in South Africa, 1
ETL	Extract; transform and load - a process in database usage and especially in data warehousing, 21
FDA	Food and Drug Administration US Government Agency, 22
Flame	A data stealing virus that has swept through the Middle East, 18
Flash™ Adobe Systems Incorporated	A feature rich web page enhancement based on the ActionScript language, 7
Flow of goods	The logistic movement of products; equipment; energy etc. in order to satisfy the localised needs of activities, 17
GIS	Geographical Information Systems, 19
GPRS	General packet radio service, 18
Graph	A data structure linking various data nodes via any number of links between them, 15
GUI	Graphical user interface, 8
GUID	Globally unique identifier, 5

Hardcoded	Coding where configuration data is effectively coded into the source of a software project, iv
High quality data	Data with diligent participation of enumerators; low attribute inaccuracy and low spatial inaccuracy, 14
Interactive data map	An extension of a data system. Therefore not only is this a system consisting of the network of important communication channels used within an organisation; but also one that can autonomously communicate along these channels and facilitate interactive access and accumulation of data, 4
IP	Internet protocol; such as IPv4 or IPv6, 18
ISO	International Standards Organisation, 3
IT	Information Technology, 27
ITU-T	Telecommunication standardisation sector of ITU, 74
J2ME	Java 2 Platform Micro Edition, 25
JavaScript	A client side web page scripting language, 7
JSON	JavaScript Object Notation, 30
Latency	The time that elapses between a stimulus; such as a web data request and the response to it; such as the presentation of data in a graph, 61

Lineage	The property of a data structure where future implementations may reuse inherited properties from historically created structures or elements thereof, 14
Load shifting	Moving energy usage from peak periods to periods where it has a less strenuous effect on the energy supplier, 4
Logical consistency	A data structure has logical consistency if its topology makes sense, 14
M&V	Measurement and Verification, 47
M-Bus	Also Meter-bus. A physical communication bus related to remote data acquisition of electricity or gas meters, 18
Macro	A single computer instruction that leads to a sequence of commands being executed, 36
Mapped planning layers	Various integrated layers on a map that provide planning strategies especially for resource management, 21
Mapping schema	Layout of elements and their links to each other. Schema is also synonymous with a database in SQL jargon, 15
Maximum notified demand	The maximum power that might be required by an operational site, 47
MIME	Multipurpose Internet Mail Extensions, 41
MySQL™ Oracle	Previously a trademark of Sun Microsystems™- this is a database management system that facilitates a dialect of the database language; SQL, 7

Nodes	These are connected points. These nodes may represent persons; organisational structures and operational sites, 5
Normative controls	Controls that give norm based directives or rules for things such as behaviour in a working environment, 23
OAN	Optimisation of Air Networks, 57
Parsed	Analysed syntactically, 8
Paths	Sets of concatenated links - one after the other, 16
PDF	Portable document format, 7
PHP	Pre-HTML Processor language, 7
PHP's mailParse extension	An extension providing interfaces to extract data from email; cf. Fiji web design: http://www.fijiwebdesign.com , 41
PITS	Population Information Terrains are virtual data spaces which support visualisation of; and cooperative work within; shared data, 14
PRF	Pseudo-random function, 41
PRP	Pseudo-random permutation, 41
Pushing	In source code management pushing is a word to indicate the transfer of data or code to a single or various backup servers, 53
QoS	Quality of service, 19

RAGE	Regional Applied General Equilibrium, 23
RDBMS	Relational database management system, 16
Reg-ex	Regular expressions, 8
REMS™	Real-time Energy Management System, 57
RF-Mesh	Radio frequency-mesh [13], 18
RtoL	Root-to-leaf (or initial node to end-node paths), 15
SAS	Statistical analysis software, 22
SAST	South African Standard Time, 55
SCADA	Supervisory control and data acquisition system, 18
SEAI	Sustainable Energy Authority of Ireland, 74
Semeiotic	Semeiotic is a spelling variant of a word used by Charles Sanders Peirce for the study of signs; likewise as 'Semiotic;' 'Semiotics' and 'Semeiotic'. Semeiotic will be used throughout, 13
SINTACS	A principal component analysis method used in the water industry, 20
Skynet	This code name for the interactive data map is inspired by the automated artificial intelligence defence system from the Terminator movie series, 32
SMS	Short Message Service, 6
SMS service provider	A company that provides access to an automated mass SMS platform; e.g. Clickatell - http://www.clickatell.com/developers/php.php , 40
SOA	Service-oriented architecture, 18

Spatial inaccuracy	This exists when coding errors with regard to addresses or identification errors occur, 14
SQL	Structured Query Language, 7
SQL99	Also identified by SQL:1999 and SQL3; the fourth revision of the SQL; structured query language ISO standard; the latest being SQL:2008, 16
SSH	Secure shell, 52
Structured primary channels	Main channels of communication, 26
Stuxnet	A worm that spreads through the Microsoft™ Operating system and targets Siemens™ industrial equipment and software, 18
System demand	Simultaneous power required by electricity users connected to the electricity grid, 1
Type I visualisation error	Tendency to see patterns that do not exist, 15
Type II visualisation error	Failure to notice patterns and relationships, 15
Ulco	A cement factory located in the Northern Cape close to Delpportshoop, 54
UML	Unified modelling language, 39
UUID	Universally unique identifier, 5
XML	Extensible mark-up language, 16

Chapter 1

Introduction

1.1 Background

State of energy management

The purpose of an ESCo¹ is to implement services with regard to managing energy consumption in order to reduce energy costs and then claim a portion of this saving as a recompense. Their origin is found in the 1970's USA Energy crisis where companies endeavoured to profit from energy saving solutions [1]. In effect, the monetary value attributed to this saving serves only as an incentive to drive both the ESCo and the energy consumer to address the real problem - the unsustainable energy consumption placing a burden on limited resources.

To support the claim of limitations on resources being the root cause, refer to Figure 1.1. This data had been aggregated from the daily system status reports sent out by Eskom² for morning peak available generation and system demand³. From the figure it can be deduced that the ability of Eskom to deliver enough power is gradually decreasing with regard to the relatively consistent demand. Therefore, whilst additional sources of power are under development, the focus of the ESCo should be to uphold the sustainability of the electricity grid by managing the energy use of primary consumers.

¹ESCo: Energy services company.

²Eskom: Primary electricity utility company based in South Africa.

³System demand: Simultaneous power required by electricity users connected to the electricity grid.

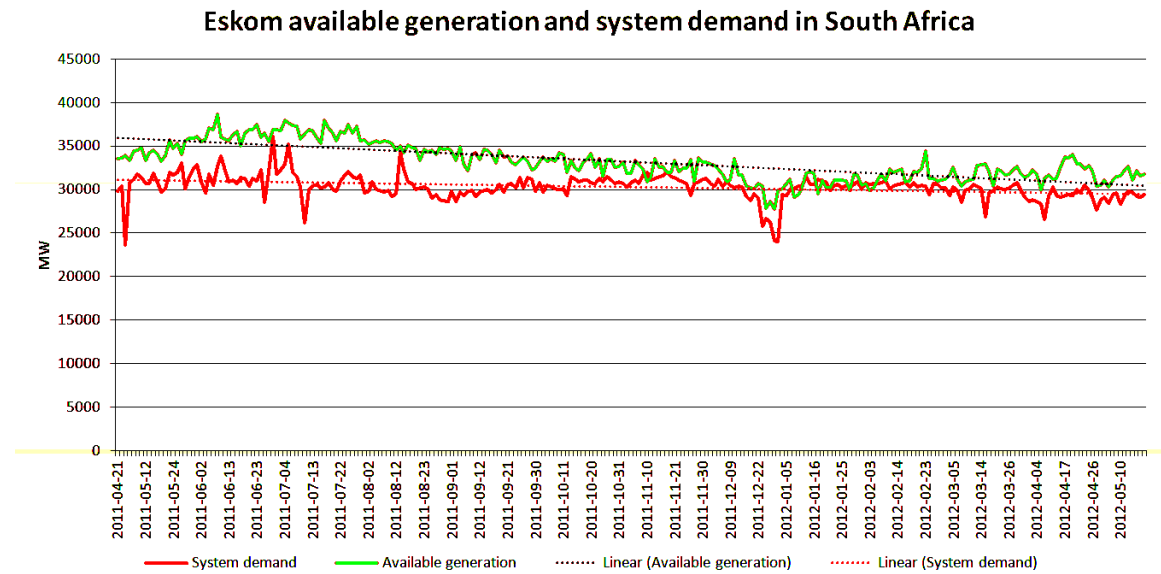

Figure 1.1: Eskom's available generation indicating a steady decline over the period April 2011 to May 2012 [2]

The pending additional sources of power include the planned Solar Valley development, [3], near Karoshoek in Upington, South Africa. There are also Kusile, Medupe and Ingula. The Karoshoek installation might resemble the existing installations of solar energy plants in Spain. Such lower carbon footprint developments still do not necessarily address power availability during the peak periods because of irregular radiation.

This is true unless the power is stored via storage methods such as the water displacement strategy. Unfortunately water displacement might not be feasible everywhere due to the absence of geographic requirements and water scarcity. The mountainous height difference utilised by the Drakensberg and Palmiet pumped storage schemes is one of these geographic requirements [4]. Because of the delay in supply capacity due to pending sources it is required that the ESCo has to ensure timely consumption on the demand side in order to sustain a stable grid.

In the gold mining sector, the primary form of energy that enters the system is in the form of electricity. This indirectly affects the availability of coal in a mainly coal-fired electricity network

as is the case of South Africa. In the cement industry for instance, depending on the focus of operations, the primary consumed resource may be either coal (production) or petroleum (mining, transport). These commodities are under pressure due to unsustainable use.

The way people and the automated systems they build should use energy need to be under the delegation of company policy.

The actions of the personnel on operational sites are based on instructions from management structures. These actions are one of the main concerns in the effective implementation of DSM⁴ projects. There exists a definite requirement for effective communication in order that the specifications of policies shall be met.

A standard that might be implemented by companies that strive to operate in a sustainable fashion is ISO⁵ 50001. This is a standard for EnMS⁶ which is based on the ideas brought about by the person responsible for the Japanese industrial revolution after the Second World War, Dr. W. Edwards Deming (†1993) [5, 6]. A solution to the communication requirements would be even more helpful if it supported the implementation of a standard such as ISO 50001.

The Irish Energy Management Standard, IS393, is a practice based standard proposed to be used for energy agreements services in the S&E Regional Operational Programme 2007 - 2013 [7]. In the same sense, as the data mapping of concern to this study, the mentioned programme proposes to provide an *Energy MAP* which is based on interactive web tools and training.

Data maps exist for the purpose of visualising information. They enable people to grasp complex data structures. An interactive data map has the additional functionality of interaction with the data by people and systems. This interaction may include navigation through parts of data structures or the physical manipulation or extraction of the underlying data.

⁴DSM: Demand side management.

⁵ISO: International Standards Organisation.

⁶EnMS: Energy Management Systems.

1.2 Research question

Need for this research

This study aims to show that an interactive data map⁷ may be used as a method of linking decision makers to those who implement policy. It is proposed that a data map can be implemented to serve as an effective tool for the management of energy in specific industries. This data map would not only have access to the physical energy consumption data and budget targets, but also provide a means to assign responsibility and facilitate communication between personnel.

In effect this data map will serve as the link between management and personnel who take part in implementing energy efficiency⁸ and load shifting⁹ projects. The data map is not intended to be restricted to this specific implementation in energy management. It will also provide the functional components as stipulated in the specifications of Section 3.2.

1.3 Research goals and chapter overview

The three primary research objectives of this study are:

- The design and building of a web-based interactive data map system.
- Implementation as a tool for control, communication and policy compliance in the specific industry.
- Quantitative and qualitative measurement of its efficacy as a management tool intended to reduce energy costs and prevent unplanned energy consumption.

⁷Interactive data map: An extension of a data system. Therefore not only is this a system consisting of the network of important communication channels used within an organisation; but also one that can autonomously communicate along these channels and facilitate interactive access and accumulation of data.

⁸Energy efficiency: Using less energy through efficient machinery and intelligent control.

⁹Load shifting: Moving energy usage from peak periods to periods where it has a less strenuous effect on the energy supplier.

Design and building

The data map is to be composed at the interface level of a multitude of nodes¹⁰. Each of these nodes is linked to other nodes. Together they form a networked structure. The system will allow a user to navigate throughout the network by either moving from node to node or, more, if a higher depth level is viewed. A simple search function will suffice in finding specific nodes in the mapped data instantly.

A many-to-many relationship is utilised but complexity is inhibited by only allowing structures of the directed acyclic type (cf. Section 2.3). This will allow the stored network graph which links all the nodes, to have lower query time than for instance in a recursive type of graph. Nodes are uniquely identified and the number of them limited by the size of the unique identifier for each node. The idea of a unique identifier is referred to quite often in software [8] where history, storage and data structures is of importance. It can be related to an identifying hexadecimal key known as a GUID¹¹ or UUID¹².

This same unique identifier is used to link a number of attributes to each node. Each of these attributes may have certain functionality attached at the client-side or server-side application level. Some attributes can be incorporated into the graphical navigation component and for all practical purposes hidden from the user. Other data fields however, are made visible to the user in the form of data capturing or display elements. This may include simple text fields, web camera captures, file uploads and many more.

In order to allow the building and adaptation of the data map's nodes, it is required that functions, such as copy (either by linking or by duplication), is allowed for in an edit mode. Along with this there should be the ability to perform operations such as moving a node, removing a node or an operation where existing links between nodes can be broken.

¹⁰Nodes: These are connected points. These nodes may represent persons; organisational structures and operational sites.

¹¹GUID: Globally unique identifier.

¹²UUID: Universally unique identifier.

Since the structure can be edited, the user might find the feature of specifying specific attributes for a node helpful. But if attribute types can be added they should also be allowed to be removed. With all this functionality at hand, persons having to build or adapt a structure for a specific implementation, such as the management of energy, might find it difficult if there are no defaults available. Therefore default node types, attribute types and even default values for these attributes is a requirement and they should be specified at an administrative level.

Implementation

The links between the various nodes of the data map are there to represent existing as well as new communication channels. The new communication channels include the automated daily and monthly reports delivered via e-mail for various projects and associated personnel. Instant alert SMSs¹³ can also be sent to specific personnel groups. The ability of the data map to take on both a hierarchical and a networked structure enables it to model actual management control structures.

Quantitative and qualitative measurement

Through daily DSM reports along the communication channels provided by the data map, project and site staff will know whether their energy savings projects' usage is within the proposed savings range. Also, in the case of data loss or malfunctioning equipment or control systems, relevant personnel will be able to identify discrepancies in the reports and act upon them promptly.

The data map facilitates an integral part of this very necessary feedback loop in the systematic management of energy. Therefore its effect can be partly attributed to savings targets being reached. It could therefore also be possible to find a quantitative correlation between the data reports sent out and the extent of energy savings for projects that make use of the data map.

¹³SMS: Short Message Service.

The following target phases will be included in the design and methodology:

- The building of a software data map system.
- Integration with an existing energy management system.
- Documentation.
- Implementation.
- Identification of possible areas of enhancement and adaptation to other clients' specifications.

The build and design of a data map system

To effectively implement a data map, it is important that it is constructed with a well designed database component at the root of its functioning.

Since this specific data map is integrated into an existing energy management system which utilises the PHP¹⁴/Apache^{TM15}/MySQL^{TM16} web package, the decision of the primary language is simple in that it will be PHP. On the server-side, there will therefore also be components utilising SQL¹⁷ and there may exist dependencies upon some external programs for handling mail, images and PDFs¹⁸.

Additionally client-side functionality will be provided by components based on Flash^{TM19} and JavaScript²⁰. There shall however be no restriction as to the language for future implementation,

¹⁴PHP: Pre-HTML Processor language.

¹⁵ApacheTM: This is a web server service that can manage dynamically typed web server code such as PHP.

¹⁶MySQLTM Oracle: Previously a trademark of Sun MicrosystemsTM- this is a database management system that facilitates a dialect of the database language; SQL.

¹⁷SQL: Structured Query Language.

¹⁸PDF: Portable document format.

¹⁹FlashTM Adobe Systems Incorporated: A feature rich web page enhancement based on the ActionScript language.

²⁰JavaScript: A client side web page scripting language.

since the logic behind the functioning of the interactive data map is the factor that matters most in its design. Refer to Chapter 3 and Chapter 4 for more detail in this regard.

Integration

The initial integration of the interactive data map into an extensive energy management system is done by utilising it as a tool to indicate data sources for electricity accounts. These accounts are electronic documents which are received via e-mail with a specific subject line - allowing for automated processing. They are then converted to text and parsed²¹ via Reg-ex²² for various pre-defined fields that are then transferred into the database of the energy management system.

The account parsing and scheduled e-mail monitoring system forms a part of this study in the context of the greater energy management system. The integration step performed by Werner Bouwer, Pr.Eng., mentioned in the previous paragraph serves to indicate to a sufficient extent that the use of especially the chosen commercial Flash based data map interface component, *Constellation Roamer*, will be able to provide the functions required at the client-side interface.

A generic version of this data map follows the integration. The ability to manipulate its structure via a Web based GUI²³ is bourne²⁴. Here various precautions need to be taken. Especially at the application to database interface there could exist for instance the infinite recursion of a complex data structure²⁵. Chapter 4 discusses some of the PHP third-party components. The reader might also deduct the extent of production level testing from the logins discussed in Chapter 6.

²¹Parsed: Analysed syntactically.

²²Reg-ex: Regular expressions.

²³GUI: Graphical user interface.

²⁴Bourne: To become a feasible idea: in the sense of a goal set for this purpose; bounded by the necessary scope and specifications.

²⁵Complex data structure: This refers to graph structures where certain nodes may need to be evaluated more than once to process all linked nodes.

Literature study

The tabulated headers listed in Table 1.1 indicate the extent of the scope of the literature study of Chapter 2.

Table 1.1: Overview of literature

Uncertainty in semeiotics
Software techniques in data mapping
Application of data maps and data mining strategies
Energy management through intelligent control
Data mapping that includes GIS
Management and personnel systems
Addressing the temporal nature of data
The ability of data systems to adapt
Aspects of management control
The evolution of control

Implementation

This system is implemented as part of a complete management system in various industries which include cement production as well as gold and other ore mining industries. The option of utilising it in water transportation management systems will also be evaluated in future. Refer to Chapter 5.2 for detail regarding the environment in which this software is implemented.

Result inference

The developed software system must be methodologically tested. Results of these procedures will determine if the interactive data map is built to a high operational standard.

The monitoring of the use of the interactive data map system may be conducted from statistical analysis of log-ins, e-mails, generated reports and SMSs which are logged in the energy management system. Furthermore, it will be possible to evaluate the extent to which budgeted energy and cost targets are reached by the various operational sites.

The effect of the use of the system can be associated with the accuracy of actual targets being reached. If enough users make use of the system, a meaningful analysis may find a positive correlation. In Chapter 6 the reader will encounter results with regard to projects reaching their respective targets consistently. The verification and validation of specifications is also presented in Chapter 6.

Enhancement and adaptation

Since this specific data map system is implemented in practice with industries where the needs may differ, there is a maintenance level objective. The objective entails gaining perspective into the additional needs and demands of the various clients utilising this system. This is in order that the system can either be extended or documented in such a fashion that it would be possible to address these requirements. The reader might find that Chapter 7 focuses on proposed enhancements and additional applications and an overall conclusion is presented in Chapter 7.3.

The following results are expected from implementing a data map as an aid for energy management:

- Effective management of energy.

It is expected that this system will succeed in providing a means for more effective energy management.

- Budget adherence.

The positive effects of the system should include greater compliance to policies and adherence to budget targets by participating client organisations.

- Usefulness as a communication, organising and management tool.

The system will be regarded as an efficient way to communicate, organise and manage various aspects of human resources, documentation, and especially DSM projects.

- Adaptive modelling of management structures.

This system will closely model the actual management structure and will be able to adapt to changes over time.

The following economic sectors will benefit from this research:

- Energy Savings Companies

The ability of an ESCo to package the specialised services provided and detailed in the interactive data map enables it to be more efficient in the reporting and communication of daily and monthly results from DSM projects.

- Underground mining and industry

In these industries great progress has been made as to the implementation of the management system and on a daily basis, energy usage data is added. Various primary role players have been registered as users of the system. Ongoing communication between the development team and the role players is evidence that this industry will be the most appropriate choice for the primary case study.

- Cement industry

The data map is serving as an adjustable communication channel that provides various key on-site personnel and project engineers with timely delivery of verified reports. These reports are generated by the energy management system and verified by ESCo personnel. Relevant staff can use the additional intelligence for optimisation of schedules and enhanced allocation of funding for energy efficient machinery, maintenance and control instrumentation.

- Water supply and distribution

The possibility of providing similar energy savings services to the water industry would indicate that such an interactive data map has a wide scope of application.

- Electricity utility industry

Since the demand side is controlled more effectively the energy utility companies such as Eskom will have a more stable electricity grid. The need for drastic measures such as large scale load shedding and down time will be minimised.

Chapter 2

Literature study

2.1 Chapter introduction

The chapter initiates with a brief overview of the theory of the functions of signs and symbols. Efficient translation and representation of data as well as unsupervised pattern discovery and supervised concept learning are also looked at. An implementation specific proposal of a model formulation and active intelligent control in the mining industry are briefly discussed. It is followed by a view of an environmental risk mapping application utilising GIS that closely reflects the representation of data in a practical manner.

Furthermore the management of personnel risk and addressing the need for time relevant data are brought into perspective. The mapping process of existing data to a new format represents the adaptability of systems. Control in a management environment focusing on benefiting organisational goals are discussed. This flows into a role based control hierarchy for risk control and manageable levels of information from the UK. The chapter is finalised by a discussion of the effect of digital communication on human organisation and followed by a few conclusive remarks.

2.2 Uncertainty in semeiotics

Semeiotics¹ entails the study of meaning with regard to the philosophical theory of the functions of signs and symbols. Several terms and purposeful elements for the visualisation of information,

¹Semeiotic: Semeiotic is a spelling variant of a word used by Charles Sanders Peirce for the study of signs; likewise as 'Semiotic;' 'Semiotics' and 'Semeotic'. Semeiotic will be used throughout.

especially uncertain information, is introduced by [9] and [10]. Locational verity for instance refers to the attribute of data that allows it to conform to its actual location. Furthermore [9] recalls elements required by a proposed digital cartographic standard in 1988.

These elements include: locational accuracy, attribute accuracy, logical consistency², completeness³ and also lineage⁴. [9] also noted that analysts are to a certain extent uncertain about the available characterisation of particular data objects within the context of risk assessment circles. In the idealistic situation, where data could be regarded as perfect, the following is required: complete participation of enumerators⁵, absolutely no attribute inaccuracy⁶ and no spatial inaccuracy⁷ [9].

With these all true, which seem almost impossible to fully satisfy even in a very efficient data acquisition system, temporal errors such as delays between acquiring data and actually interpreting it still has not been satisfied [9]. A variability in data is ascribed by [9] to the combination of spatial aggregation and attribute aggregation. It is further noted that categorisation always introduces uncertainty even with data of high quality⁸ [6]. This is quite similar to the quantisation error introduced in the conversion of analogue data into digital form.

The focus of [10] is more on practical standards based sharing of data through systematic approaches such as PITS⁹, that aims to enhance database technology with prominent features of Virtual Reality and CSCW¹⁰.

²Logical consistency: A data structure has logical consistency if its topology makes sense.

³Completeness: Comprehensive data and systematic ways of dealing with values.

⁴Lineage: The property of a data structure where future implementations may reuse inherited properties from historically created structures or elements thereof.

⁵Enumerators: Persons or systems collecting data.

⁶Attribute inaccuracy: Misunderstanding in the data collected or even deliberate misinformation.

⁷Spatial inaccuracy: This exists when coding errors with regard to addresses or identification errors occur.

⁸High quality data: Data with diligent participation of enumerators; low attribute inaccuracy and low spatial inaccuracy.

⁹PITS: Population Information Terrains are virtual data spaces which support visualisation of; and cooperative work within; shared data.

¹⁰CSCW: Computer Supported Cooperative Work.

Of critical note are the following issues that need to be addressed in order for the generation of displays and interfaces to work: The approach must be methodological, compliant with technical specifications and be ergonomic¹¹ [9].

Other contributions made, are the incorporation of several additional graphic variables to "Bertin's basic system of graphic variables," which historically included, location, size, value, texture, colour, orientation, and shape [9, 10]. Firstly, it is asserted that both size and value from this system are the most appropriate variables for depicting uncertainty in quantitative information. Secondly colour, hue, shape and even orientation is regarded to be more suited for the indication of uncertainty in qualitative information. Texture is noted to be appropriate for both nominal (qualitative) or numerical data [9, 10]. Saturation and focus are inclusions noted to be good indicators for the measure of certainty [9].

Focus is performed in four different ways: contour crispness, clarity of fill, fog and resolution [9]. The types of visualisation errors described by [9] is Type I¹² and Type II¹³ and these are therefore also regarded as starting points for an evaluation of a visualisation system.

This concludes this overview of semeiotics.

2.3 Software techniques in data mapping

Efficient translation and representation of data graphs¹⁴ (as shown in Figure 2.1) is not a simple matter even with advanced software architectures. For instance, according to the introductory discussion by [11], "[if] the mapping schema¹⁵ is recursive, the number of root-to-leaf paths will

¹¹Ergonomics: The branch of engineering science in which biological science is used to study the relation between workers and their environments.

¹²Type I visualisation error: Tendency to see patterns that do not exist.

¹³Type II visualisation error: Failure to notice patterns and relationships.

¹⁴Graph: A data structure linking various data nodes via any number of links between them.

¹⁵Mapping schema: Layout of elements and their links to each other. Schema is also synonymous with a database in SQL jargon.

be infinite for certain leaf nodes and the *RtoL*¹⁶ query for such nodes is the union of infinitely many queries."

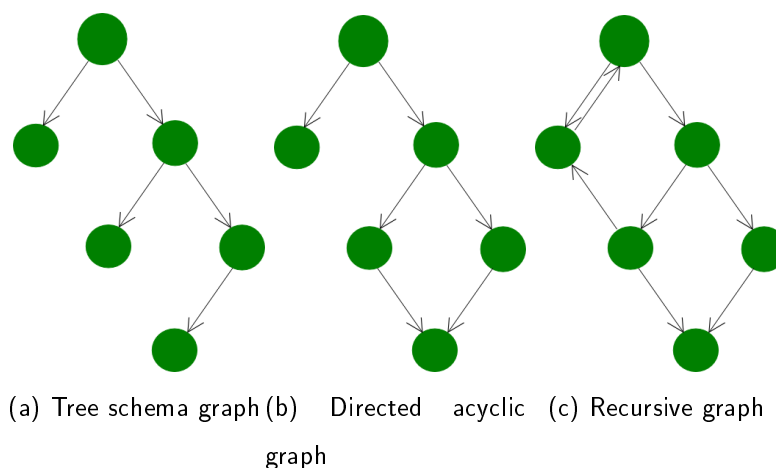

Figure 2.1: Graph examples

These graphs consist of three classes, a tree schema graph (e.g. Figure 2.1a), DAG¹⁷ schema (e.g. Figure 2.1b) and the most complex due to recursion within the network itself, is the recursive schema graph (e.g. Figure 2.1c) [11]. Besides the complexity of the recursive schema graph, [12] claims to have succeeded in being the first to present a solution for an efficient SQL99¹⁸ query approach to provide the functionality of mapping between XML¹⁹ and the relations in a RDBMS²⁰.

In Figure 2.1 the top node represented by a dot is the root node. Following the arrows (links) from this node various child nodes may be encountered. A node that does not have any children (and therefore no arrows flowing from it to other nodes) is regarded as a leaf node. For example,

¹⁶RtoL: Root-to-leaf (or initial node to end-node paths).

¹⁷DAG: Directed acyclic graph.

¹⁸SQL99: Also identified by SQL:1999 and SQL3; the fourth revision of the SQL; structured query language ISO standard; the latest being SQL:2008.

¹⁹XML: Extensible mark-up language.

²⁰RDBMS: Relational database management system.

Figure 2.1c has three nodes. The recursion referred in the *recursive* schema graph regards the paths²¹ that flows from an initial node to its child nodes and then revisits some of the nodes in the structure without necessarily ever reaching a leaf node.

2.4 Application of data maps and data mining strategies

The representation of databases as graphs is studied by [14] in the *Subdue* system which performs unsupervised pattern discovery as well as supervised concept learning from examples. Another application is in the spatial visualisation of ecosystem services [15]. Depending on production schemes [15], "self-sustaining systems have a higher capacity for a sustainable use of natural capital than import-dependent systems." It is indicated by [15] that assessments in a spatial manner using maps seem to be appropriate for the purposes of visualisation in ecosystem services, but [15] goes further and indicates supply and demand through an integrated assessment matrix.

With regard to the carbon sequestration service which goes hand in hand with energy management [15] notes that this needs to be balanced only at the global scale, whilst other forms of supply and demand are more localised. It is mentioned that ecological service evaluation methods exist, such as carrying capacity²² and the ecological footprint approach²³ and these may lead to a monetary valuation of ecosystem services (with biophysical units as basis).

Maps are highly regarded by [15] for their ability to illustrate spatial phenomena, distributions and their interrelations, showing areas where action is required - even to non-specialists. Maps are also mentioned to reveal patterns of natural conditions and human activities over time and

²¹Paths: Sets of concatenated links - one after the other.

²²Carrying capacity: A method that aims at quantifying the number of individuals of a given species that a defined habitat can support indefinitely.

²³Ecological footprint approach: A method that focuses on the demand side by calculating the resource consumption of a population; expressed in biologically productive area with global average hectares as measurement unit.

2.4. APPLICATION OF DATA MAPS AND DATA MINING STRATEGIES

most definitely for their usefulness in the analysis of source and sink dynamics as well as the related flow of goods²⁴ [15].

An example data map given by [15] reveals areas of "energy surplus" as well as areas with an "energy deficit" in respectively green and red. [16] introduces aspects of the Department of Energy (USA) Data Explorer as a relatively new and unsophisticated research tool allowing access to stored and maintained data-sets.

[17] demonstrates a smart grid model for energy management which is constituted of smart meters at residential, commercial and industrial sites, linked to a multi-vendor, multi-technology, multi-utility concentrator of data via a M-Bus²⁵, RF-Mesh²⁶, IP²⁷ or GPRS²⁸ interface.

When the data is concentrated, it is sent off for the purpose of computer analysis again via IP or GPRS before it is allocated via SOA²⁹ to end interpretation nodes. Such data could be fed back into electricity grids, energy suppliers or multi-site industrial and commercial companies' databases.

The use of SCADA³⁰ is not highly regarded by [17] due to potential security risks. However, owing to the amount and variety of SCADA systems still in use, support could by no means be withdrawn due to possible security flaws. The transgression of control systems and data theft in Iran by several viruses, such as *Stuxnet*³¹ [18] or *Flame*³² [19] is evidence of such flaws in

²⁴Flow of goods: The logistic movement of products; equipment; energy etc. in order to satisfy the localised needs of activities.

²⁵M-Bus: Also Meter-bus. A physical communication bus related to remote data acquisition of electricity or gas meters.

²⁶RF-Mesh: Radio frequency-mesh [13].

²⁷IP: Internet protocol; such as IPv4 or IPv6.

²⁸GPRS: General packet radio service.

²⁹SOA: Service-oriented architecture.

³⁰SCADA: Supervisory control and data acquisition system.

³¹Stuxnet: A worm that spreads through the MicrosoftTM Operating system and targets SiemensTM industrial equipment and software.

³²Flame: A data stealing virus that has swept through the Middle East.

existing control systems.

2.5 Energy management through intelligent control

[20] proposes a model of an EPSM³³ and thus adapts a Power State Machine to include the state of an embedded program in the power state machine formulation. In the case study, of a wearable computer in the medical field, [20] found that one factor that critically influences performance is the power consumption.

In order to provide the required services at an optimised energy consumption level [20] dynamically made adaptations to the QoS³⁴. This is done with regard to changes in the battery charge as well as the state of computation over a period of time.

The EMS³⁵ of [21] implements an energy management solution which utilises optimised control on mine compressor systems. This system provides data that is used in the web based EnMS of which the data map forms a component. Similar customised systems enables the systematic control of pumps, winders, fridge plants and cement mills. Optimised production line schedules are used on cement plants for efficient energy usage.

The energy usage and instrument statuses on these controlled and monitored systems is the primary data concern. Data accuracy is key. It is noted by [22] that in order to successfully implement an ESCo procedure, it is necessary for control systems to function efficiently. [22] argues that calibration data may be inaccurate when such systems, such as a BMS³⁶, are not operational.

³³EPSM: Extended Power State Machine.

³⁴QoS: Quality of service.

³⁵EMS: Energy Management System.

³⁶BMS: Building Management System - a computerised control system.

2.6 Data mapping that includes GIS

[23] provides an insight into a practical environmental risk mapping application which utilises GIS³⁷. [23] identifies specific risks for the environment that can be brought to the attention of users (especially farmers) of the mapping system namely soil compaction and aquifer pollution - the latter being a possible threat in the mining industry too.

[23] implements a spatial distribution map of precipitation, aquifer water table depth and finally an aquifer vulnerability map based on a SINTACS³⁸ model [24, 25]. Both SINTACS and its predecessor DRASTIC³⁹ are methods by which the principle components particularly in the water industry are identified before modelling and data representation commence.

A model for the sharing of data with regard to geographic information is studied by [26]. [26] describes their platform as a provider of information in order that various processes can be based upon it. These include research strategies, decision-making, planning, response in a state of emergency and particularly the implementation of major strategic initiatives.

It is argued that a description of spatial entities in the traditional fashion cannot meet the required information sharing specifications, because this description only identifies the links between elements and not necessarily their spatial relationships [26]. The problem of integrating information residing on displaced servers by means of this traditional method is also identified by [26].

As a solution an entity oriented data description method which can integrate and manage both geometry and attribute information of geographic entities is presented since, according to [26], this would assist the data integration as well as the interoperability of spatial information in a distributed network environment.

³⁷GIS: Geographical Information Systems.

³⁸SINTACS: A principal component analysis method used in the water industry.

³⁹DRASTIC: A principal component analysis method; predecessor to SINTACS.

An intricate data-sharing model of geographic information based on their implementation specific definition of an entity is presented by [26] and this is implemented to a certain extent in a piece of experimental software, which does provide quick access to imagery and other functionality defined in their model.

There is a study, [27], into the utilisation of remote sensing technology for the monitoring and management of especially coal resources and the extent of their exploitation. It implements the integration of GIS data in order to provide mapped planning layers⁴⁰ and correlation analysis⁴¹. This is especially supportive for gaining insight into the adherence of mines to laws regarding mining restrictions as well as the estimation of resource availability.

2.7 Management and personnel systems

A patent, [28], exists for an in depth system for managing personnel risk. The patent is fully described via various functional models which indicate a multitude of the required operational complexities. This presents the system down to the level of specific data storage methods such as SQL based databases. It is also described in depth up to the user end application level.

It is evident that this kind of software design, which is reasonably implementation specific, does indeed address the need for reporting on personnel. It is, however, reliant upon gaining personnel related input from an intelligent enumerator as well as from prepared personnel profiles. In another case the ETL⁴² management tool of [29] provides an application platform for data analysis in decision-making.

⁴⁰Mapped planning layers: Various integrated layers on a map that provide planning strategies especially for resource management.

⁴¹Correlation analysis: An analysis that determines the existence of a statistical relation between two or more variables.

⁴²ETL: Extract; transform and load - a process in database usage and especially in data warehousing.

2.8 Addressing the temporal nature of data

There is also a patent, [30], for a system which intends to address the need for the replaying, according to temporal disposition, and visualisation of data based on post-performance metrics. It could be compared to an existing piece of freeware software for code control visualisation called "gource".

This temporal disposition is also a factor regarded by [9] as notable. Even though the focus of [9] is not necessarily on the ability to perform such a simulated real-time replay as [30] intended to do, this ability does partially address some of the issues [9] identifies with regard to displays and interfaces that work. Specifically, the issues addressed are, a methodological approach as well as a high level of ergonomic applicability.

2.9 The ability of data systems to adapt

[31] evaluates and tests the mapping process of SAS⁴³ data and XML. XML has been adopted by various institutions such as the FDA⁴⁴ of the USA who officially adopted it through the release of a guidance document in October 2003 [31]. The readiness of an SAS 9 XML engine for electronic submissions is also assessed by [31]. This is an example where the analytical tools used for the analysis of data of an older standard, namely SAS data, through data conversion, can still be used to analyse the newer standardised data.

Thus through a certain amount of abstraction and differentiation between data and application in the original software design level, the ability to adapt to new standards is gained. See also [32] for more on SAS Mapping and examples of various visualisation methods. One of these methods is an overview calendar that could provide temporally accurate data navigation.

⁴³SAS: Statistical analysis software.

⁴⁴FDA: Food and Drug Administration US Government Agency.

2.10 Aspects of management control

Control in a management environment is described by [33] as the means through which actions of both individuals and groups are restricted to those that benefit organisational goals. These goals would need to be documented in the organisation's operational policies and strategies.

This is required in order that a reasonable method of checking the effect of management control in attaining these goals could exist. The RAGE⁴⁵ model's feasibility for assisting policy makers in the South African context is studied by [34]. This model is a specialisation of the AGE model⁴⁶, adding both regional and spatial components.

A breakdown (as adapted from [33]) of the broad categories of control, regulative and normative, is given in Table 2.1. The strategy of mapping data would come into play by supporting the financial and quality controls of Table 2.1. Mapped team and organisational structures would fit in with the normative controls⁴⁷ of Table 2.1.

Table 2.1: Types of control

Regulative Controls	Normative Controls
Bureaucratic Controls	Team Norms
Financial Controls	Organisational Cultural Norms
Quality Controls	

Three reasons for using theoretical models, such as RAGE, is given by [34] as improved understanding of economic processes, the ability to make predictions and the analysis of the most likely effects of economic policy and alterations thereof. The practicality of these models when applied (becomes CGE⁴⁸) are regarded with caution. This is due to uncertainty with respect

⁴⁵RAGE: Regional Applied General Equilibrium.

⁴⁶AGE: Applied General Equilibrium model.

⁴⁷Normative controls: Controls that give norm based directives or rules for things such as behaviour in a working environment.

⁴⁸CGE: Computable General Equilibrium.

to their quantitative accuracy. However, [35] discusses hardware and software that actually calculates solutions to supposedly complex and high dimensional problems. CGE models are also attributed the virtue of escaping bounds laid by linearity in modelling [36].

2.11 Focusing on role instead of rank in management

The UK implements a role based control hierarchy for risk control [37]. This control hierarchy breaks down the chain of command at three primary role positions that may adapt depending on the kind of crisis encountered. The main reasons for this role based approach is stated as maintaining manageable levels of information and tasks at each level of command.

The reasoning behind this is that information travelling down the chain of command gets more refined and situation specific as it is passed on. Upwards flowing information tends to get filtered in such a way that high levels of command can make decisions on a more global scale to ensure a return to normality from a crisis situation.

The manageable levels of information through the filtering process of [37] in either a control hierarchy or network is also mentioned by [38]. A quantitative justification through the use of a mathematical "complexity profile" for the noticeable increase in complexity of existence is presented by [38].

The analysis of this profile by [38] allowed for recognising the fact that human civilisation in itself is capable of behavioural complexity that exceeds that of the individual. Examples of random, coherent and correlated behaviour is presented at the levels of physical, biological and social systems by [38] and a concise form of this is represented in Table 2.2.

Table 2.2: Random coherent and correlated behaviour in different systems [38]

Random	Gas	Pond life	Crowds
Coherent	Cannonball	Infections	Armies
Correlated	Snowflake	Humans	Corporations
	Physical	Biological	Social

The "complexity profile" of [38] is closely related to the complexity of detail present at a certain scale or level of command [37]. The "complexity profile" is a numeral indicator of the amount of independent behaviours that are visible at a particular scale. One might consider the infinite complexity of fractal images to visualise this such as the Julia fractal of Figure 2.2 which had been generated with the ProPaintMobile J2ME⁴⁹ application from a photo.

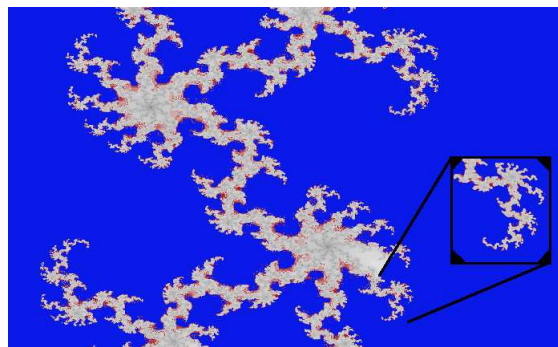

Figure 2.2: Fractal image to illustrate visible complexity at different scales

At larger scales the complexity gradually decreases but the amount of information that needs to be considered at the higher levels might become quite extensive. This leads to a situation in which for instance a manager is unable to communicate effectively with all employees communicating through her/him in the conventional hierarchical control structure [38].

⁴⁹J2ME: Java 2 Platform Micro Edition.

An initial solution might be a decreased branching ratio⁵⁰ as [37] proposed. But according to [38] this solution is defeated the very moment that the complexity of collective behaviour increases beyond that of the complexity of an individual.

Therefore, the hierarchy is naturally replaced with a network that supports a higher amount of lateral communication channels. This serves to lower the load along the structured primary channels⁵¹ of hierarchical and even hybrid control structures. It is especially at the "higher" levels of management where data is to be condensed that an interactive data map would supply a high level overview of the effect of complex lower level strategies and instrument control systems.

The correlation between the complexity of an organism or organisation with regard to the complexity of its environmental demands that is required to sustain a certain form of behaviour is discussed by [38]. This behaviour can be paralleled to that of the electricity consumer.

The environmental demand on the other hand is based on the availability of resources and the manner by which these are utilised by the suppliers to provide the necessary electricity in order to provide a sustainable consumer electricity supply. If the complexity of the organisation is on par or exceeds that of the environmental demand, then only can the organisation survive. Otherwise it will fail according to the discussion and graphical representation of [38].

2.12 The evolution of control

[39] coins the term "wirearchy" as "a dynamic flow of power and authority, based on information, trust, credibility and a focus on results, enabled by interconnected technology and people."

⁵⁰Branching ratio: Amount of child nodes connected to a node; e.g. the number of individuals supervised by one manager.

⁵¹Structured primary channels: Main channels of communication.

⁵¹Hybrid control structures contain combined aspects of hierarchical and network topologies but does not necessarily enforce the degree of lateral communication as is evident in networks

This highly philosophical article, [39], gives an alarming overview of how the medium of the control of humans is being shifted into a digital, wired form in contrast to the hierarchies of early known history.

It is also hypothesised by [39] that the IT⁵² infrastructures of organisations in combination with the expanding scope and use of smart software will lead to a kind of "integrated nervous system" which in turn will provide both top management and workers with a feedback loop focusing on improvement and learning. It can by no means be argued that this process is not exactly what is intended to be achieved through this development and accompanying study for interactive data mapping for energy management in industry.

2.13 Conclusive remarks

With regard to semeiotics, various useful attributes of a system that presents data to the end user could be extrapolated. Representation and management of data through the use of graphs of various complexity levels were indicated. The usefulness of maps and associated data mining strategies served to focus on some of the many positive aspects of using data maps to present data to users. Access to accurate data from lower level control systems were indicated to be essential and this is where the data map finds its purpose.

Widening the scope to GIS applications allowed for the consideration of other ways of presenting data. One pilot implementation of indicating an overview site data by a colleague of the author did indeed make use of an interactive South African map. Examples of existing personnel systems, time based data visualisation and adaptable systems were discussed. Management control and focusing on the roles of persons rather than their rank were portrayed as an effective strategy for a productive corporate environment. The effect of the digital age on the way humans organise themselves to obtain systematic feedback loops on their operations were also illustrated.

⁵²IT: Information Technology.

Chapter 3

Design analysis

3.1 Chapter introduction

In this chapter various specifications are listed and this leads to a functional breakdown where a design philosophy integrating the user, administrator and developer is proposed. The design from the three perspectives follows in more detail. The chapter is closed of with a few conclusive remarks.

3.2 Specification statement

The specifications are based on the requirements identified in chapters 1 and 2 and grouped according to primary objectives. The terms "software" and "data map" are to be regarded as synonymous with the software artifact developed for the interactive data map system.

Specifications

1. A web-based interactive data map system shall be designed and built in order that it complies with the following:
 - (a) It shall serve as a solution to the communication requirements in the industry;
 - (b) It shall utilise an interactive data map as a method of linking decision makers to the policy implementers;
 - (c) The software shall provide a means to assign responsibility and facilitate communication between responsible personnel;
 - (d) Furthermore it shall support communication regarding energy efficiency and load shifting projects.

- (e) The following functionality shall be provided for by the interactive data map:
 - i. graphical navigation,
 - ii. link and node management,
 - iii. attribute value specification,
 - iv. type specification,
 - v. web-cam integration,
 - vi. file uploads and downloads,
 - vii. integrated e-mail and
 - viii. integrated SMS.
 - (f) The interactive data map shall support colour coded status indication:
 - i. The colour coding shall be based upon predetermined defaults, and where applicable;
 - ii. The colour coding shall be based on the actual values of specified attributes or specific links between nodes of the data map.
2. The software shall be implemented as a tool for assisting the users thereof in the following aspects:
- (a) control,
 - (b) communication and
 - (c) policy compliance.
3. The software's capabilities as a management tool shall be measured by means of both:
- (a) quantitative means and
 - (b) qualitative means.
4. In order to facilitate an ergonomic design with regard to semeiotic requirements:
- (a) The data map should be locationally accurate with regard to links between nodes;
 - (b) Attributes should be given accurately for each and every node;
-

- (c) The data map should be logically consistent in the sense that its topology will make sense;
 - (d) The data map should be complete in the sense of:
 - i. providing comprehensive data and
 - ii. systematic ways of dealing with values,
 - (e) The data map should support lineage in the sense of one being able to build a map utilising historic map nodes and structures,
5. In order to support high quality data the following technical specifications should be met:
- (a) The participation of multiple persons or systems collecting data should be supported in an:
 - i. asynchronous, and
 - ii. distributed setup
 - (b) Attribute inaccuracy should have a means to be corrected;
 - (c) Spatial inaccuracy should have a means to be corrected.
 - (d) Acquired data should be available immediately to persons utilising the data map for as far as network speed, hardware and supporting software capabilities support.
 - (e) Where aggregation suppresses spatial and attribute data there should exist a means of expanding the data map to provide a more detailed perspective.
6. The interface should work in a methodological way:
- (a) In order to diminish Type I visualisation errors a user should be able to adjust the depth level of visible data to see only a required portion;
 - (b) To lessen the probability of Type II visualisation errors a user should be able to adjust the depth level to a large depth in order that specific patterns may be noticed.
7. The data map should be able to translate data effectively:

- (a) From a MySQL database back-end to XML or JSON¹ for use by the visualisation component;
 - (b) From user input and interaction on the visualisation component to the database storage system.
8. The data map should at least support graphs of the directed acyclic type.

3.3 Functional breakdown

In order to integrate the interactive data map into the EnMS it is supplied with various interfaces that serve to orchestrate the interaction of especially three entities, the general user, the structure administrator and most certainly the code developer. It is of high importance that since this system is extensible and should be sustainable that the developer not be left out when regarding the system in its entirety. This extensibility lies in the sense of additional functionality that may be made available in future iterations of the data map in answer to specific client service requests.

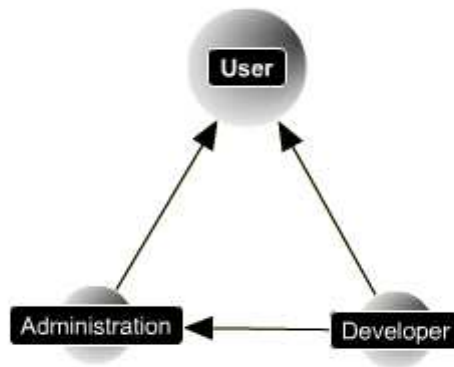

Figure 3.1: The data map system serves as an interface between user, administrator and developer.

¹JSON: JavaScript Object Notation.

3.4 User perspective

Overview

The user sees the data map within his/her browser through a window split three ways. This visual interface is denoted *Skynet² Manager*. It is constituted from three functional entities, the data map region denoted as *Skynet Viewport*, the data entry/submission area identified as *Skynet Submit*, and a control interface known as *Skynet Control*. Refer to Figure 3.2 for the basic layout.

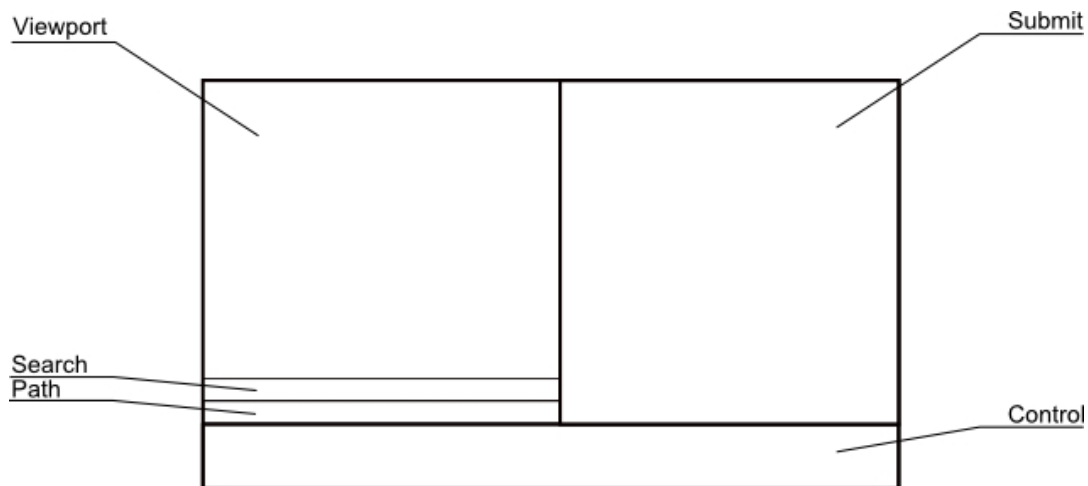

Figure 3.2: Client side basic manager layout

Skynet Viewport serves as the visual representation of the intraconnections between data elements denoted as "nodes." The visual display is performed by a suitable third-party software package, such as 'Constellation Roamer' (an Adobe Flash based interface) or 'JIT' (a JavaScript based interface - JavaScript Infovis Toolbox.)

²Skynet: This code name for the interactive data map is inspired by the automated artificial intelligence defence system from the Terminator movie series.

Skynet Submit serves as a display of the attribute data of a currently selected node from *Skynet Viewport* and in an editing mode may also be used to enter additional data values and fields. The user has the ability to select certain fields according to administrative design.

Skynet Control has different sets of controls depending on the current mode of operation. Two modes are defined. They are "view mode" and "edit mode". Further specialised controls could be specified for specific users through a user rights management interface accessible by an administrator.

Modes of operation

In "view mode" there are controls for sending SMS or e-mail as well as depth control buttons to enable the user to adjust the depth of visibility (linked nodes circling out from the selected) seen through *Skynet Viewport*. The ability to select an appropriate filtering scheme is also provided for, as is a legend. Navigation capability is provided by allowing the user to jump to a "parent node" of the currently selected node.

When in the "edit mode" the *Skynet Manager* interface utilises cross-frame scripting in order to channel client-server requests through a single frame, which upon arrival and completion of rendering in the client browser, loads accompanying frames that require refreshing. Simply navigating through the data map only loads the attribute data frame. This holds true when utilising the navigational controls too.

Lineage

If a user were to have two or more browser windows open with the same or even different data maps they would be able to copy/move entire structures over from the one window to the other since the "root node" of a copy/move operation is stored within the user's session. This interesting feature may be quite useful in doing away with tedious structure transfer tasks such as manual data entry or file download and upload.

3.5 Administrative perspective

Editor

The administrator manages the data map defaults and options from within a browser through a linked list selection interface, *Skynet Editor*. In order to give the administrator the maximum amount of control, without compromising simplicity of use the whole set (cf. Figure 4.2b), consisting of scheme, node, field, value and colour is presented at a single glance and yet the setting of certain colours in accordance to certain data values or adding new default options (such as nodes, fields or values available to the user) is intended to be intuitive and easy to understand.

Legend

The *Skynet Legend*, which is displayed from the user perspective, is entirely based on the connections and colour coding decisions made by the administrator and implemented via *Skynet Editor*. The actual editing of a data map, through *Skynet Manager* also actively reflects the administrator's pre-determined setup.

3.6 Code management and maintenance perspective

Testing

Testing entails the execution of a series of tasks that a user would perform to achieve a specific goal regarding the maintenance or use of the data map. This could be the transfer of a specific employee in one department of the business to another location at the abstract level of the data map.

Such an operation will reflect actual events or support the planning for future events. From the user perspective, the sequence of events that would lead to such a transfer is depicted in Figure 3.3.

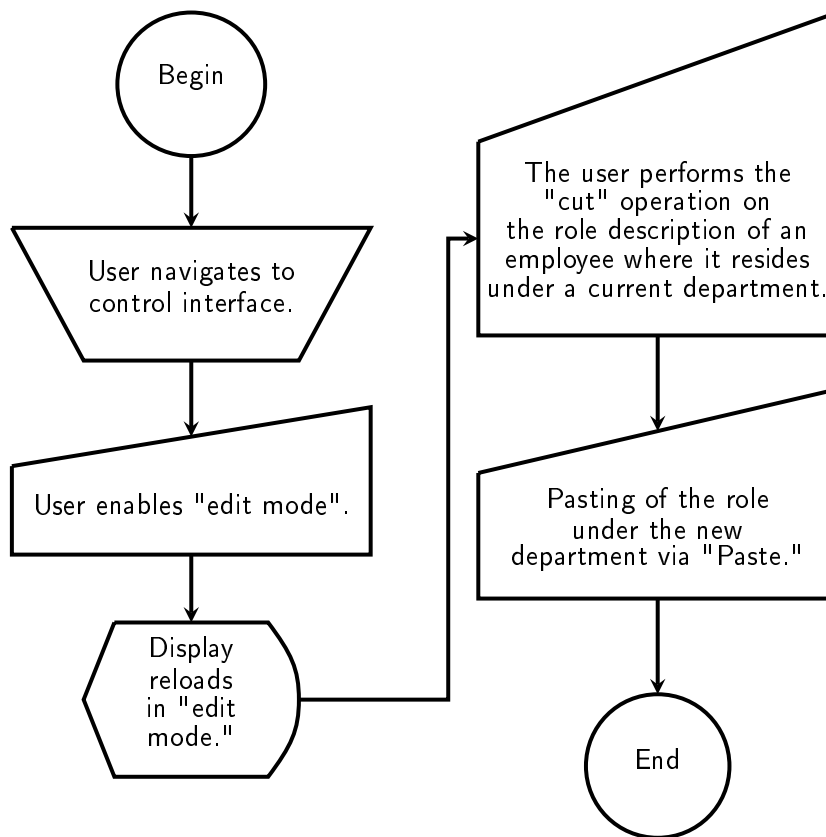

Figure 3.3: User interaction sequence for transfer operation

Behind the execution of these commands is an HTML, JavaScript and Flash based user interface which can be mostly debugged via client side browser developer tools such as the "Firebug plug-in" in Mozilla™ Firefox, or the F12 built-in debugging tool in Microsoft™ Internet Explorer.

Utilising these tools one could easily monitor the "POST" and "GET" requests from the browser at each step of the user perspective testing sequence.

Error fixing

Using the Apache™ web server's logs, user reports (via EnMS's built in e-mail enquiry system) and the mentioned browser debugging tools, specific lines of code or functions causing the erratic behaviour may be identified. A well documented function library which includes

descriptive specifications for each function will support the identification and fixing of errors until the functions act as intended and understood, by users of the interactive data map.

Feature addition

Proposed enhancements:

- The "Jump up" command might be linked to a parent path, selected from "Skynet Path" by the user, rather than just jumping to the first found parent.
- Additional built-in help and assistance tips might lead the user through the "Skynet Manager" interface.
- It had become necessary to filter available schemes according to a specific user to prevent information overloading. This functionality is therefore already implemented.
- Making the interface more compatible for the mobile market might become necessary since the map can then be made more accessible to employees in the field and on the road. This might require not using any Flash™ content as this is mostly not supported very well throughout the spectrum of mobile devices and mobile operating systems, especially on lower end devices [40].
- A macro³ mode that records and enables the replay of structural setups may be considered. In a sense, through code re-use a higher level command, such as "Merge" that merges two nodes both with regard to attributes as well as structural links, repeatedly uses the sequence for the "Copy" operation.

³Macro: A single computer instruction that leads to a sequence of commands being executed.

3.7 Conclusive remarks

Beyond the specifications a functional breakdown with a novel user, administrator and developer approach were given. With regard to the user perspective, the visual overview as well as modes of proposed operation were discussed. The necessity of lineage in the creation of data maps were also indicated. From the administrative perspective the required editing and legend components were mentioned. With regard to the developer perspective, the code management and maintenance focused on testing, error fixing and the implementation of possible enhancements. These enhancements are not necessarily already part of the specifications.

Chapter 4

Detailed design

4.1 Chapter introduction

In this chapter a snapshot of the logical interaction between various code artifacts is presented. It is followed by the allocation of objects, both with regard to the relational database as well as code objects integrated into the system. Screen shots are used to illustrate the graphical layout of actual interfaces for both user and administrative interaction with the system. Reference to a detailed tutorial regarding interaction with the system is made. After this the chapter is concluded.

4.2 Logical interaction

The communication and dependencies between various PHP code artifacts are represented in Figure 4.1. These artifacts were derived from the actual code project with the assistance of *BoUML*¹.

¹BoUML software package: This efficient universal modelling software was previously released as freeware by the French developer; Bruno Pagès; but it is commercially available from <http://www.bouml.fr>.

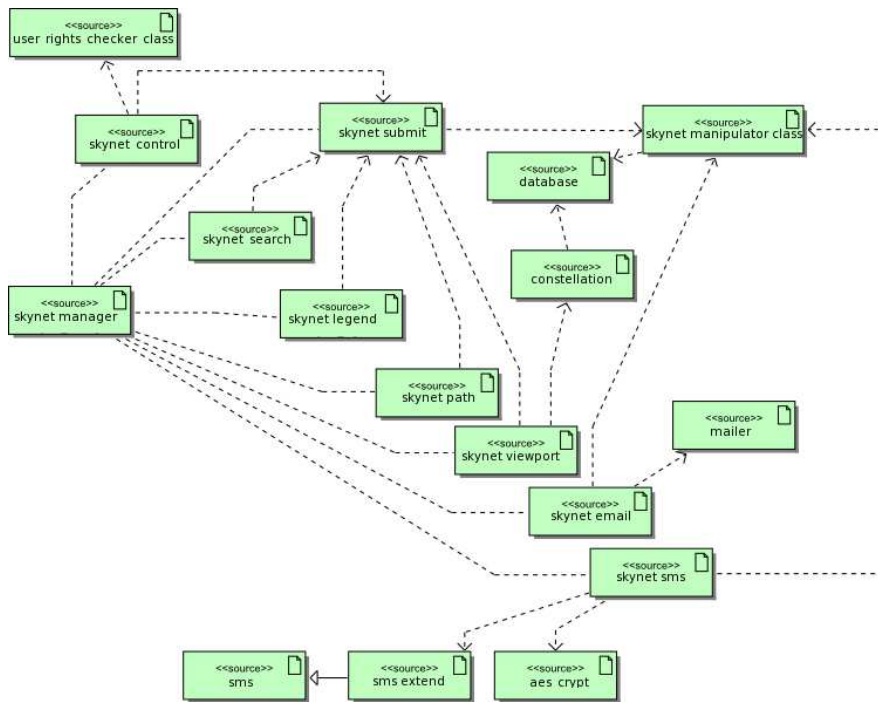

Figure 4.1: Artifact interaction

4.3 Object allocation

The UML² diagram of Figures 4.2a and 4.2b, may enlighten the reader as to the layout of the basic database structure of the data map. On the left the data map structure and attributes in its entirety is stored and on the right additional default values and behaviour or status colouring is stored at an administrative level.

²UML: Unified modelling language.

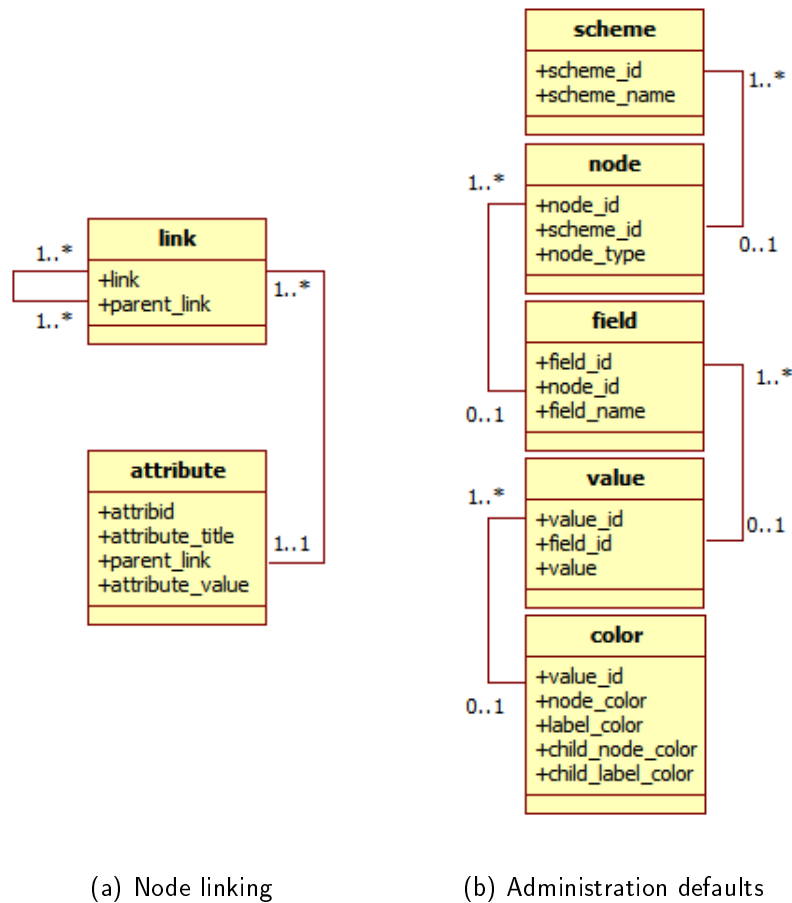

Figure 4.2: UML diagram for data map's database tables

The following classes³ form integral parts of the functionality provided by the interactive data map, and they may have been authored by either colleagues or other PHP programmers who released their code into the public domain:

- *SMS*, *SMSDatahandler*, *SMSDatahandlerExt*, *SMSStatus* and *ClickatellStatus*

These classes provide the functionality of submitting SMS data, querying and updating the status of SMS delivery. The author is primarily S. Cox and credit is also given to Dr. W. Bouwer, Pr Eng, and the PHP help from the SMS service provider⁴.

³Class: From programming jargon - a template for code objects.

⁴SMS service provider: A company that provides access to an automated mass SMS platform; e.g. Clickatell - <http://www.clickatell.com/developers/php.php>.

- *Database*

The objects of this class is used globally as an abstraction to the interaction of most objects within the EnMS that utilises the SQL database to store or retrieve information.

- *Data*

This class acts as an overview of the availability of data from the various operational sites.

- *Constellation* and *ConstellationNode*

These classes was originally coded by Dr. W. Bouwer, Pr Eng, and have been adapted since by the author to facilitate the simultaneous multiple access characteristics through unique IDs and MySQL to XML mapping.

- *Control* and *ControlDashboard*

These classes provide navigation as well as an overview of the interactive data map.

- *PHPMailer* and *phpmailerException*

These classes provide the lower level e-mail handling utilised by the objects of the *Mailer* and *EmailPassOn* classes coded by the author.

- *MimeMailParser* and *MimeMailParser_attachment*

This is a fast MIME⁵ mail parser class using PHP's *mailParse* extension⁶

- *Aes*

This is an AES⁷ implementation in PHP by Chris Veness. This is the basic block cipher AES algorithm that uses a secure PRP⁸.

- *AesCtr*

This class provides an AES counter (CTR) mode implementation in PHP by Chris Veness.

⁵MIME: Multipurpose Internet Mail Extensions.

⁶PHP's mailParse extension: An extension providing interfaces to extract data from email; cf. Fiji web design: <http://www.fijiwebdesign.com>.

⁷AES: Advanced Encryption Standard.

⁸PRP: Pseudo-random permutation.

This algorithm is slightly faster than the previously mentioned cipher in that it directly uses a secure PRF⁹.

Integral PHP classes required in the interactive data map system, primarily coded and maintained by the author, are these:

- *UserRightsChecker*

This class provides a security mechanism to limit access to specific functionality provided anywhere within the greater EnMS as well as within the data map's control interface. Access to editing and automated user registration can be restricted in the control interface through the functionality provided by this class.

- *Mailer*

Provides simple and also more complex multi part attachment based mailing functionality in a simple object based format to all classes within the EnMS that require it.

- *EmailPassOn*

This class utilises regular expressions based e-mail subject and contents identification in order to pass the information contained within the received e-mails on to the correct processing artifacts before the data is automatically made available on the EnMS.

- *SkynetManipulator*

This class serves as a function library for data manipulation and interaction with the database storage system of the interactive data map.

- *MergePDFTablesIntoSystems, WaterPDFToDB, DMPPDFToDB, SystemExec*

These classes provide the required functionality of processing received document data and storing it in structured fields within the database of the EnMS. These classes handle among others: Eskom electronic electricity accounts, various South African regional water account formats and DMP¹⁰ data reports.

⁹PRF: Pseudo-random function.

¹⁰DMP: Demand Market Participation.

- *SubgroupManipulator*

This class serves as a function library for providing a filtering mechanism for users who should see only a sub-sector of a client group's operational sites and their affiliated data and totals.

- *IsoControl*

This class provides an interface to an overview of the ISO 50001 (cf. Chapter 1.1) process in order to enable users of the EnMS to be aware of the extent of this standard and the implementation thereof.

- *ViewerInterface*

This class provides generic data graphs and quick reporting functionality. The data graphs presents the system user or data map linked manager with one day delayed, two minute interval raw instrumentation and control data. This data is gathered from a data aggregation component of the EnMS for the quickly growing hundred actively monitored DSM projects.

4.4 User interface

In this section the focus is on the visual and interactive aspect of the data mapping software. The user interface, as seen from a web browser, is depicted in Figure 4.3.

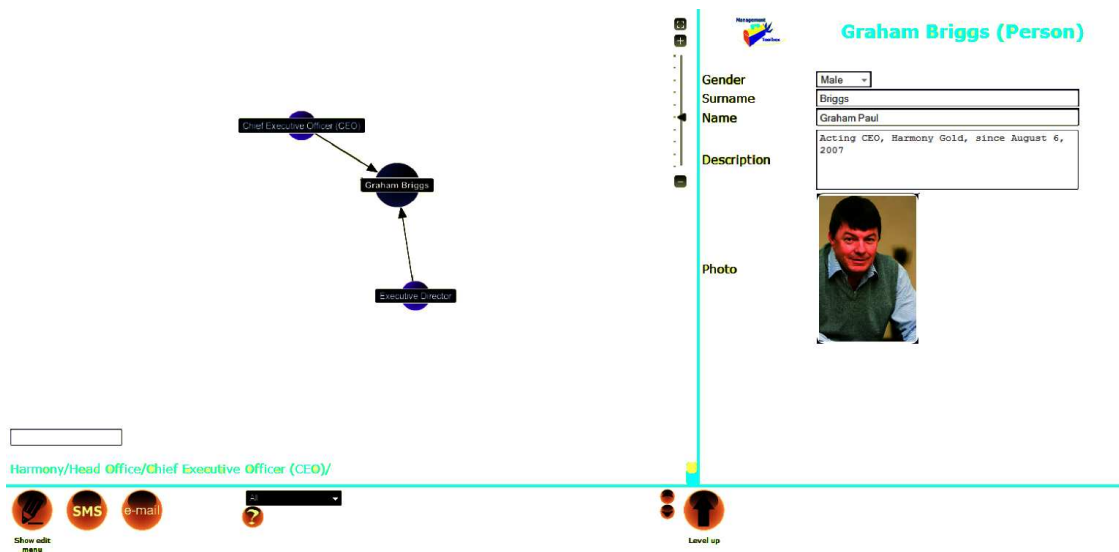

Figure 4.3: Interactive data map user interface

The data map's structure with the bubbles representing nodes and the arrows indicating the directed flow of communication and linkage is evident from Figure 4.3. As the reader might note, the details of the person selected in the structure on the left hand side, is presented on the right hand side. Here the reader might note the possibilities with regard to human resources management.

Refer to Figure A.21 in Addendum A for a screen shot regarding the ability to send a group SMS directly from the currently selected node to all persons with the relevant mobile number details. In order to illustrate further functionality provided by the data map in detail, the reader is referred to the screen shots and discussion in Addendum A.

4.4. USER INTERFACE

There is also an interface that depicts ISO 5001 processes and links these to functionality provided by the web-based EnMS. This is presented in Figure 4.4.

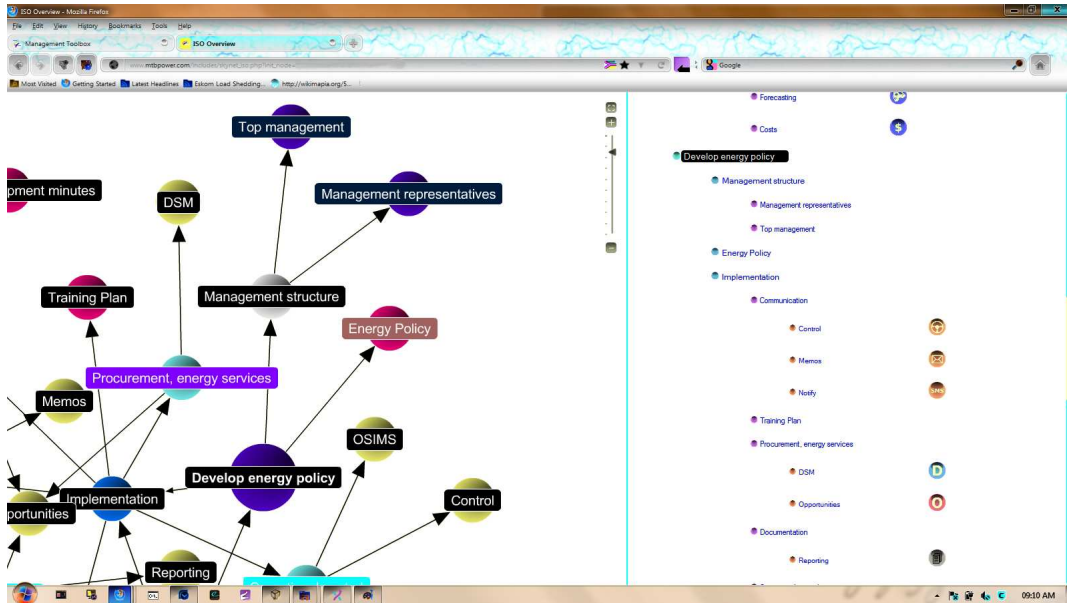

Figure 4.4: Interactive data map used to indicate requirements for ISO 5001

The administrative interface used to set up the available fields and default selections, as well as specific colour coding for certain selections, is depicted in Figure 4.5.

Schemes	Nodes	Fields	Values	Node colour	Label colour
Person	Person	Gender	Female	Female	
Equipment	Equipment	Summaries	Female		
Project	Project	Topic	SMS		
Role	Role	Gender	E-mail		
Committee	Committee	Personal Number	None		
Board	Board	Phone Number (Office)	Committees		
Role Group	Role Group	Phone Number (Home)	Audit Committee		
Site Group	Site Group	Mobile number	Remuneration Committee		
Group	Group	E-mail address	Sustainable Development Committee		
Document	Document	Pull message	Investment Committee		
Process	Process	Radio ID	Technical Committee		
Management system	Management system	Company	Nomination Committee		
MTB function	MTB function	GPS Coordinates	Operational Committee		
DSM	DSM	Physical Address	Board Member	MediumVioletRed	None
DSM Project	DSM Project	Data availability	Chief Electrician		
Enterprise	Enterprise	Role-label	Electrical Foreman		
Operations group	Operations group	Equipment-label	Engineer		
Operation	Operation	Committee-label	Engineering Manager		
Suboperation	Suboperation	Site-label	Not available		
year	year	Board-label	Account		
month	month	Role Group-label	Manual		
		Site Group-label	E-mail & SMS		
		Description			
New scheme	New node	New field	Add value		
Drop scheme	Drop node	Drop field	Drop value		
Ren. scheme	Ren. node	Ren. field	Ren. value		

Submit

Figure 4.5: Interactive data map administrative interface

4.5 Conclusive remarks

The logical interaction of code artifacts were illustrated. This was followed up by the relational database UML diagrams which illustrated the object based design allowing data manipulation, linkage as well as administrative behavioural setup. Furthermore the various code classes and their purpose in the broader system were listed. Finally the screen shots and references to the addendum indicated the practical user interface components that were conceptually designed and coded by the author.

Chapter 5

Implementation

5.1 Chapter introduction

This chapter discusses the software environment in which the interactive data map is utilised and indicates the various roles it plays and processes supported in the fluent operation of the system as a whole. Furthermore hardware requirements for the server and client implementations are discussed with some notes on the live upgrading and backup systems that are in place. The chapter is concluded with some remarks.

5.2 Environment

The interactive data map is implemented to serve various roles within components of the EnMS. Such components include: ISO 50001 compliance documentation and processes, data availability, control and maintenance of existing DSM projects.

Interactive and web-based ISO 50001 documentation templates are hosted on the EnMS. The data map serves the purpose of displaying the level of completion of the various ISO 50001 documents and affiliated processes.

With regard to data availability, the focus of implementation is primarily on Eskom consumer bills, which are linked to various operational sites managed on the web-based EnMS. Here the data map assists in visualising the various premises and accounts under the control of a specific client or user. Dated raw account data is provided in a standardised format for download by clients from their online data dashboard, should they require it for various arbitrary purposes. This could be manually verifying usage per site or overall administrative electricity costs.

This data and also M&V¹ committee's derived baselines (see Figure 5.1) are also used in automated processes on the EnMS to draw up various visual statistics, such as time-of-use pie charts, monthly usage and cost trends as well as cost breakdowns. Furthermore proposals with regard to time-of-use and maximum notified demand² can be made.

According to maximum notified demand rules, a fee is paid on the limit provided to the utility company, but if the power used exceeds this limit during a month, penalty fees come into effect.

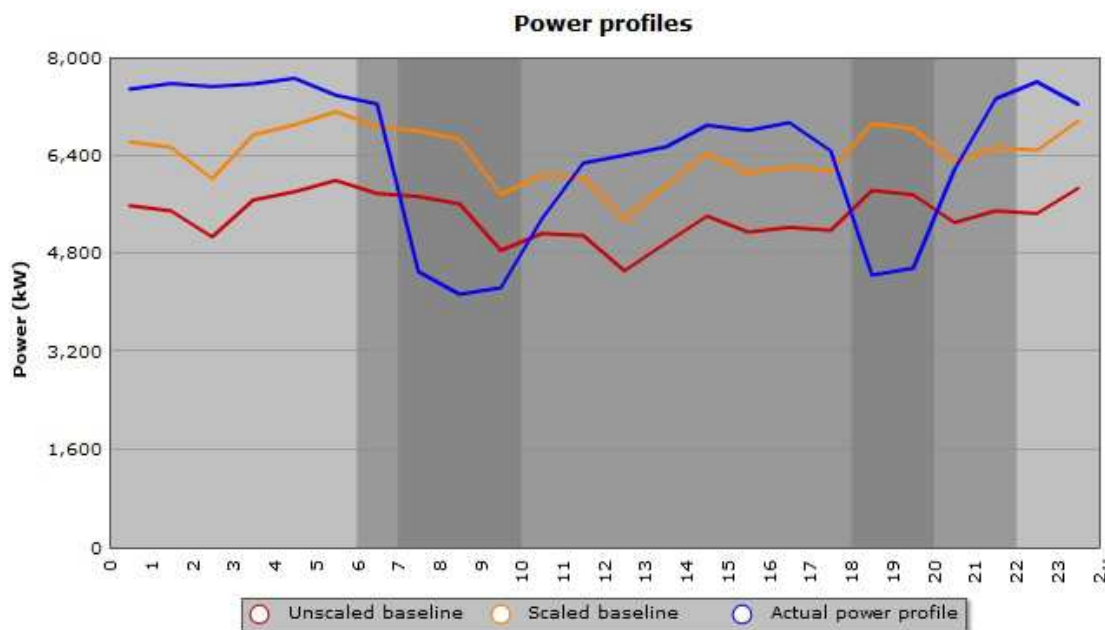

Figure 5.1: Cement industry weekdays' hourly average power profile and baseline for 1 July 2012 to 31 July 2012 (monthly report)

With regard to control, the focus of the data map is on human resources associated with various organisational bodies within a client company. The organisational bodies may include management boards and committees as well as operational structures and active projects. These

¹M&V: Measurement and Verification.

²Maximum notified demand: The maximum power that might be required by an operational site.

structures can however be customised as far as an administrator of the data map desires or client requests specifies. The data map can and have been used to build models of such organisational networks. The advantages of instant SMS and group e-mails come into play along the communication channels created in this network.

People as well as roles and bodies within such a network may have a multitude of attributes. Some of the specialised attributes that have specific functionality associated with them are interactive profile photo uploads, web camera snapshots and document uploads.

Colour coding according to, for instance gender and specific roles played within the organisation, is an aesthetic quality that is also provided by the data map, if set up as such by an administrator.

For the maintenance of historic demand side management projects by an ESCo, the data map utilises the project and personnel structures associated with control. These customisable and visible communication channels allows the web-based EnMS to automatically send out monthly as well as daily DSM reports. Some clients from the cement industry requested that they also receive specialised reports which indicate one day lag raw usage data broken down on equipment level, especially for operational cement mills (e.g. Figure 5.2).

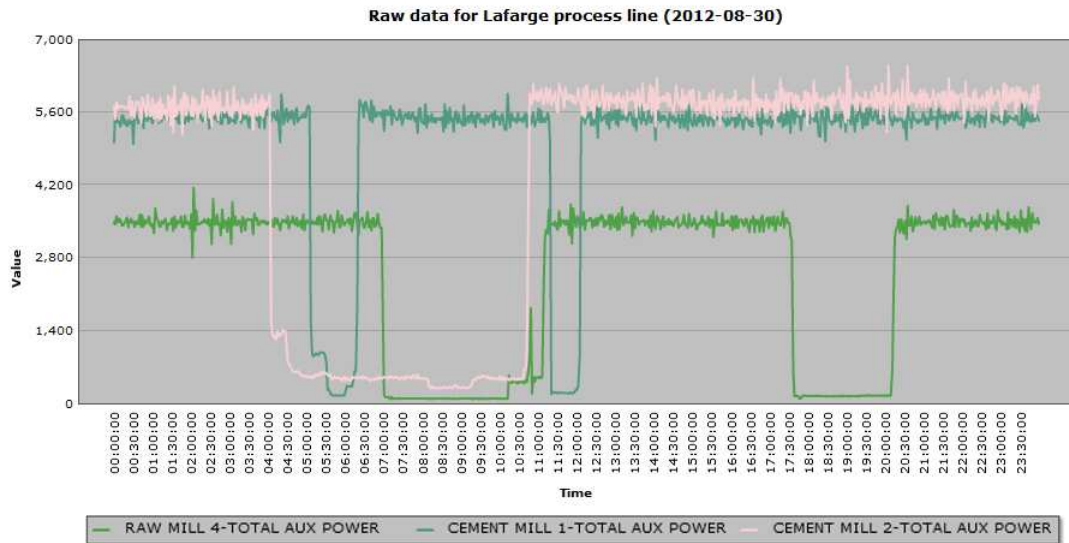

Figure 5.2: Cement industry raw data for 30 August 2012 (raw report)

It should be noted that most of the maintenance personnel never have to physically interact with the data map beyond receiving their allocated reports. This may have been set up by a few privileged users that have access to the specific organisational data map structure.

All maintenance reports are verified by administrative personnel at the ESCo offices. This process can be broken down as depicted in Figure 5.3.

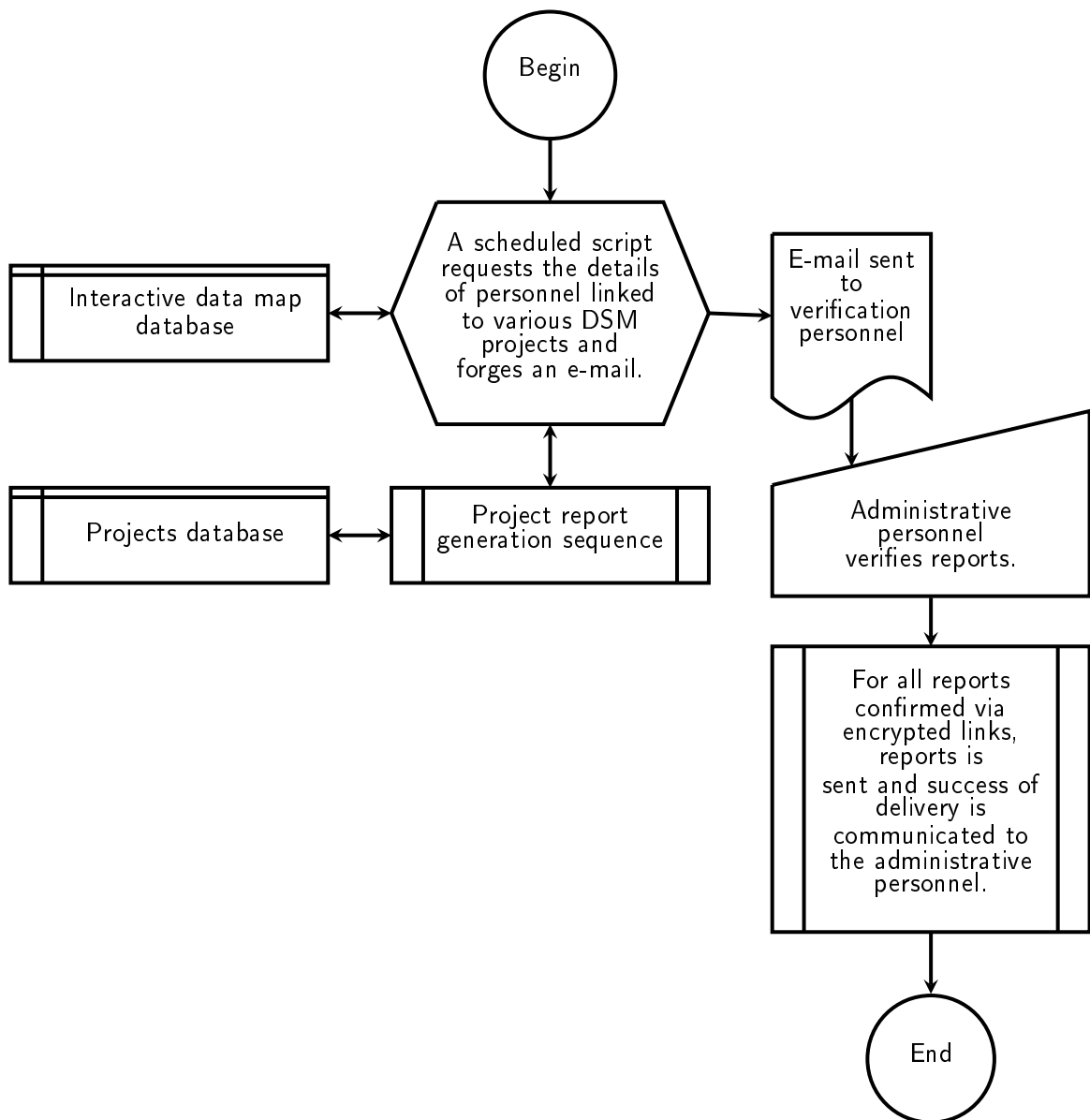

Figure 5.3: Projects' maintenance report process

This process serves to protect the verifying personnel from the complexities of managing hundreds and possibly changing mailing lists. These list are now set up and kept up-to-date in a visual manner by project specific managers or data map users that have direct knowledge of the current organisational structures for a specific operational site.

Through the use of the data map the whole system becomes more sustainable in the sense that processes continue to exist even with the natural ebb and flow of key personnel through various stages of their careers. The possibly negative effect of data overflow at various levels of the management processes are also mitigated.

5.3 Maintenance and support

Hardware and software requirements

The web based EnMS runs on Windows Server 2008 R2 and requires the minimum hardware and software requirements indicated in Table 5.1.

Table 5.1: Minimum hardware and software requirements

2.4 GHZ Intel Core 2 Duo Processor or better.
500 GB SATA HDD (with RAID)
8 GB RAM
1 GB/s Ethernet
Dedicated public IP addresses
Firewall
Mail Server (e.g. HMail)

Client setup

The client computer needs to run the latest Mozilla™ Firefox, Microsoft™ Internet Explorer or Google™ Chrome Browser with the necessary Shockwave™ Flash plug-ins installed and an Internet connection.

Upgrading

The base code on the server is updated differentially through the use of the *git* code management system over an SSH³ connection.

Backup and history

Backups and history of both code and server generated data such as files and the EnMS's MySQL database is done through automated scheduled processes. Interestingly, to ensure accurate history and differential backups, the same system that manages the code, namely *git* is also used for pushing⁴ the backups to the backup servers.

5.4 Conclusive remarks

The software environment and the role of the data map therein were illustrated. Specific hardware requirements for the server and client implementations were discussed and this was followed by notes on the existing upgrading and backup systems of the web based EnMS.

³SSH: Secure shell.

⁴Pushing: In source code management pushing is a word to indicate the transfer of data or code to a single or various backup servers.

Chapter 6

Results

6.1 Chapter introduction

The results include the discussion of a few case studies from the cement and gold industries. This is just an excerpt from many more projects managed on the web based EnMS. The influence of the the data map in these projects is indicated to be enhanced communication. Preliminary results tabulated from usage of the system for various purposes and by various users are presented next.

These results are compiled into graphs for further discussion in the processed results section. Verification and validation of functionality of the data map that addresses the specifications for it follows. Accordingly conclusive remarks are made.

6.2 Client case study

For the case study an aggregation of various projects managed and maintained with the assistance of the interactive data map will be evaluated. The DSM characteristics of various projects hosted on the web-based EnMS will be presented next. Data is presented for the period ranging from February 2012 to August 2012. The reader should note that the sudden change in cost savings were influenced by tariff increases and also higher tariffs for the three month winter peak period ranging from June to August.

This means that even though these projects may only have ensured consistently using less energy than the project energy baseline, the affiliated savings in costs due to tariff increases becomes more noteworthy during the higher tariff periods.

Ulco Process Line (Cement)

The optimisation of average power consumption on the AfriSam Ulco¹ Process Line project has an impact target of 2.70 MW over a non-condonable weekday. Since this is a load shifting project it focuses on daily transferring 13.5 MWh of electricity used in peak periods to standard or off-peak periods - the latter having a greater cost saving than the former.

The lower average power usage during peak hours (SAST²), 7:00 to 10:00 and 18:00 to 20:00, can be seen in the hourly power profile of another cement project in Figure 5.1 in Chapter 5.2.

Table 6.1 presents a summary of the influence that the DSM project engineers and on-site personnel had through optimised schedules and receiving timely reports through being linked via the interactive data map.

Table 6.1: AfriSam Ulco Process Line - DSM Summary for period 1 February 2012 to 31 August 2012 (custom period report)

	Weekdays
Average daily impact	4.05 MW
Energy consumption	20.58 GWh
Cost savings	R 3,069,179
Missed opportunities	R 24,020

Over the period noted, an impact bar graph, Figure 6.1, indicates the load shifting impact of the project over time. Note that for the period where there seems to be an absence of data, the data is marked as condonable on the web based EnMS due to increased production being implemented during this period. The cost savings graph, Figure 6.2, shows the effect on cost

¹Ulco: A cement factory located in the Northern Cape close to Delportshoop.

²SAST: South African Standard Time.

savings achieved through using less power in peak times and again the savings achieved in the condonable periods are disregarded in project performance.

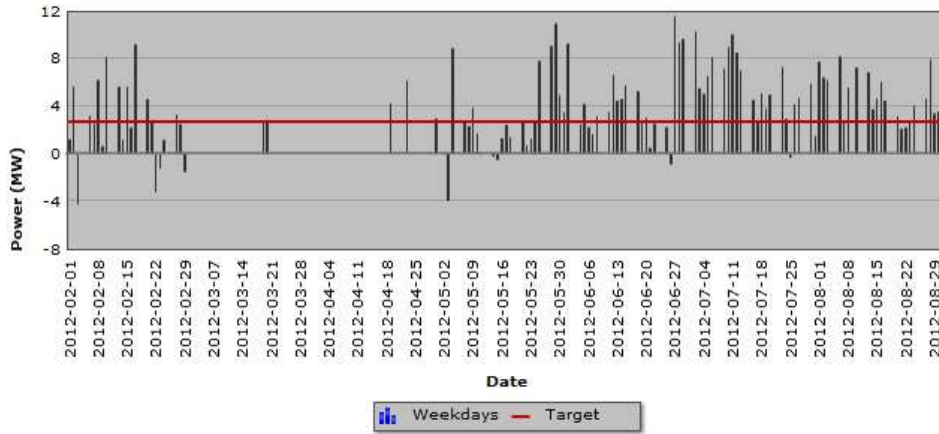

Figure 6.1: AfriSam Ulco Process Line - DSM Impact for period 1 February 2012 to 31 August 2012 (custom period report)

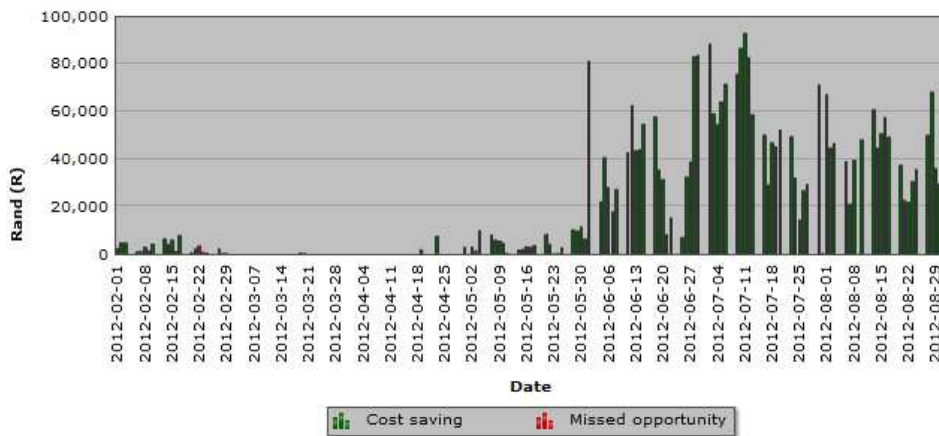

Figure 6.2: AfriSam Ulco Process Line - DSM Cost Savings for period 1 February 2012 to 31 August 2012 (custom period report)

Initially, since the implementation stages of the project only two ESCo project engineers were linked via the interactive data map. Since July 2012, however, a total of 11 persons is linked

through the interactive data map and this includes on-site personnel, who now receive daily and monthly reports for the Ulco Process Line project. A total of 152 sets of reports have been sent out since the beginning of March 2012 for this project. For comparative purposes a project from the gold mining industry is presented next.

Evander OAN (Gold mining)

Evander OAN³ is an energy efficiency project. Therefore less energy needs to be used without adverse effects on production. The optimisation of the average power consumption on the air supply of the underground levels at the Evander mining shafts and underground levels has an impact target of 1.52 MW over a non-condonable weekday. Table 6.2 presents a summary of the influence that the DSM project engineers, on-site personnel and automated compressor control (through REMS^{TM4}) had while linked personnel received reports.

Table 6.2: Evander OAN - DSM Summary for period 1 February 2012 to 31 August 2012 (custom period report)

	Weekdays
Average daily impact	6.04 MW
Energy consumption	9.23 GWh
Cost savings	R 11,015,887

Over the period noted an impact bar graph, Figure 6.3, indicates the impact of the project over time. The cost savings graph, Figure 6.4 shows the effect on cost savings achieved through using less power in peak times. In this project there occurred a loss of data due to the failure of on site communication hardware during the period ranging from the end of April through May. Data loss is also regarded as condonable. The communication setup was reviewed by on-site

³OAN: Optimisation of Air Networks.

⁴REMSTM: Real-time Energy Management System.

personnel and data aggregation had been able to commence since.

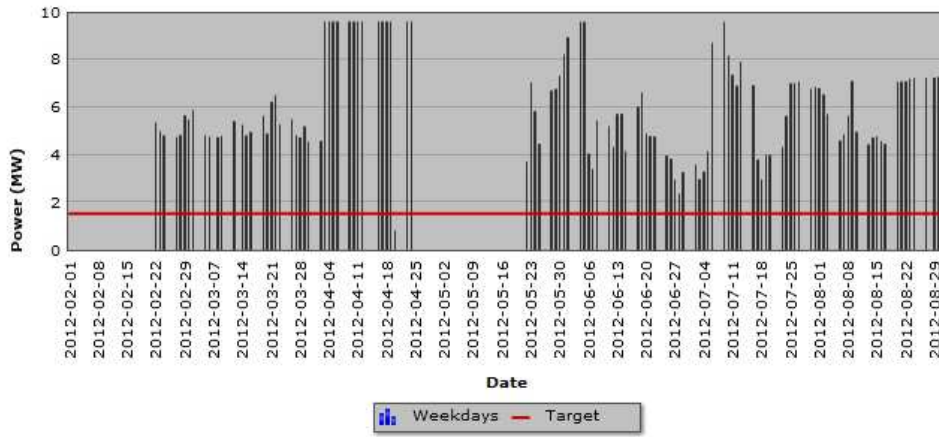

Figure 6.3: Evander OAN - DSM Impact for period 1 February 2012 to 31 August 2012 (custom period report)

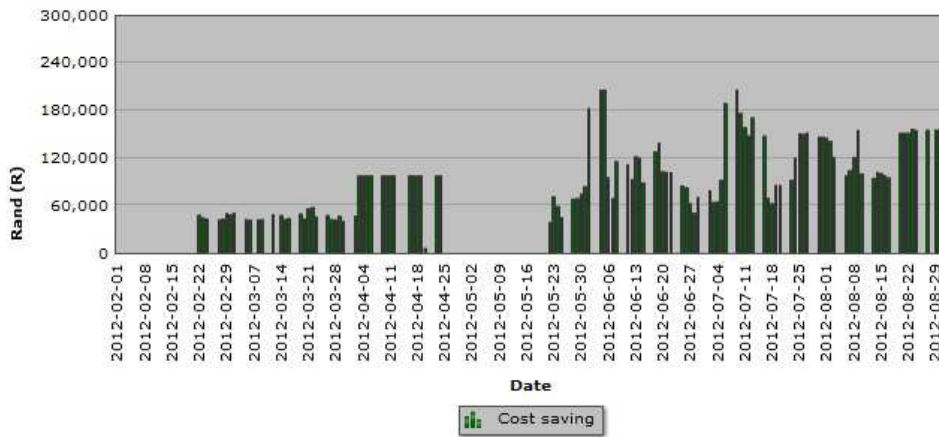

Figure 6.4: Evander OAN - DSM Cost Savings for period 1 February 2012 to 31 August 2012 (custom period report)

The Evander project has gone through a hand-over from one project engineer to another at the end of August 2012. This could be determined from checking the person indicated for receiving the reports having changed on this date. This hand-over was effectively orchestrated

through the use of the interactive data map. A total of 125 sets of reports have been sent out since the end of March 2012 for this project.

Kusasaletu CA (Gold mining)

Now the Kusasaletu CA⁵ project is presented. The cooling auxiliaries entail refrigeration equipment required to cool down water at surface level before utilising this for both cooling down air and use of the cool water at high temperature lower level operations.

Table 6.3: Kusasaletu CA - DSM Summary for period 1 February 2012 to 31 August 2012 (custom period report)

	Weekdays
Average daily impact	2.39 MW
Energy consumption	17.63 GWh
Cost savings	R 5,585,072
Missed opportunities	R 35,818

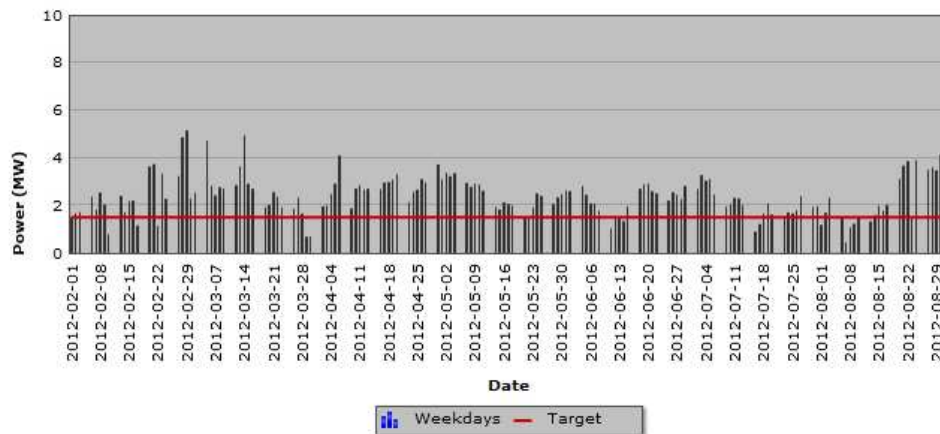

Figure 6.5: Kusasaletu CA - DSM Impact for period 1 February 2012 to 31 August 2012 (custom period report)

⁵CA: Cooling auxiliaries.

The impact bar graph, Figure 6.5, indicates consistently positive results except for a few days where the energy savings fell short of the target. The cost savings graph, Figure 6.6 gives the resultant financial implications of the energy savings.

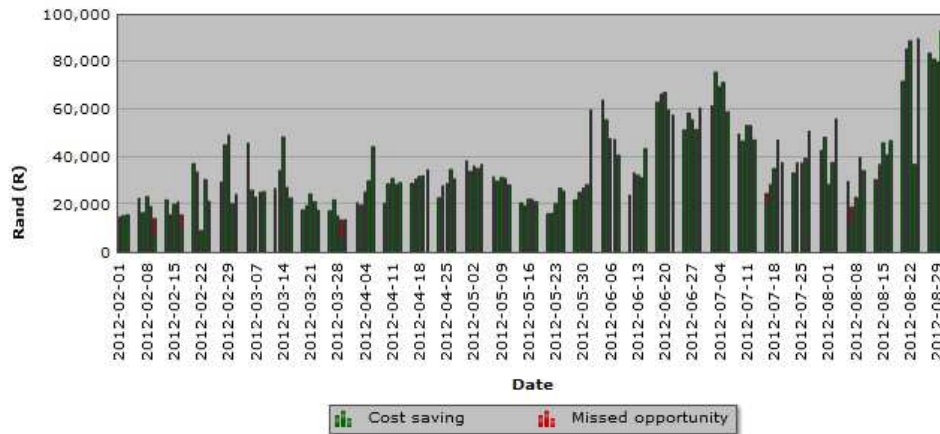

Figure 6.6: Kusasaletu CA - DSM Cost Savings for period 1 February 2012 to 31 August 2012 (custom period report)

The Kusasaletu project had one project engineer assigned for the period ranging from March 2012 up to October 2012. At this time an engineering manager was also linked to the project through the interactive data map and as such have also been receiving the daily reports since 8 October 2012. A total of 158 daily reports had been sent out to relevant personnel for this project.

Like these three projects, another 41 projects is linked to various project engineers and on-site personnel through the interactive data map. This led to roughly eleven thousand unique reports having been delivered to key personnel since mid November 2011. The figures indicate nothing short of effective communication.

6.3 Preliminary results

The following results depicting the use and effects of the system on energy management may enlighten the reader as to the efficacy of the data map even during the primarily development stages of the web-based EnMS.

Table 6.4: Logins - Analysis per system user

#	User name	Last stamp	Number of logins
1	demo1(test/demo gm)	2012-08-31 16:34	1527
2	projects(master projects review)	2012-08-31 08:46	1150
3	admin(administration)	2012-08-31 23:20	935
4	demo2(test/demo ci)	2012-02-21 16:02	251
5	user2(cement industry A)	2012-08-29 12:55	96
6	user4(cement industry B)	2012-08-20 14:06	88
7	user1(raw data)	2012-08-30 12:22	81
8	structure1(master data map editing)	2012-08-31 11:34	78
9	user7(gold mining)	2012-05-23 15:13	38
10	user5(gold mining)	2012-08-08 12:01	29
11	user6(cement industry C)	2012-08-03 10:06	29
12	user3(gold mining)	2012-08-27 05:23	22
13	user9(gold mining)	2012-02-21 15:59	19
14	user8(gold mining)	2012-02-21 16:00	14

In Table 6.4 aliases for actual users is used and the focus areas are identified by the bracketed descriptions such as "cement industry A." The capitals "A," "B" or "C" differentiates the specific users affiliated with different cement manufacturing groups registered on the system. Furthermore, the reader might note the differentiation of the demonstration and testing accounts through the letter sequences "ci" and "gm," indicating respectively "cement industry" and "gold mining."

The login counts represent the actual number of logins by specific users over the period starting in May 2011 and ending in August 2012. These counts exclude logins by automated and scheduled data processing and graph pre-generation scripts on the web based EnMS that run each three hours of the day to ensure a low latency⁶ when users access the site. Table 6.5 summarises the purpose for logging into the online EnMS by the various users.

Table 6.5: Logins - Analysis per purpose

	Number of logins
Test/demo	1778
Review	1150
Administration	935
Cement industry	213
Gold mining	122
Raw data	81
Data map editing	78

For a test to determine the efficacy of SMSs as a means to communicate a task; the following methodology was implemented. SMSs with IDs 7 to 59 in the web-based EnMS was sent via the data map's interactive interface to 52 electrical foremen. These foremen was linked in the data map by administrative personnel. The SMSs requested the foremen to e-mail the web-based EnMS's e-mail address with their acknowledgement of receipt.

Although all SMSs were delivered successfully, only three foremen answered. This low response rate of 5.8% might indicate some resistance to this form of communication. This could in turn be related to the high misuse of the SMS platform by mass advertisers.

⁶Latency: The time that elapses between a stimulus; such as a web data request and the response to it; such as the presentation of data in a graph.

6.4 Processed results

Figure 6.7 indicates the heavy weight of testing, demos and administration (3-5 software engineers) when compared to the cases where individual company energy managers or on-site control personnel logged in to review monthly, weekly or daily data. It should also be noted that the review of projects are done by around 30 in-house project engineers.

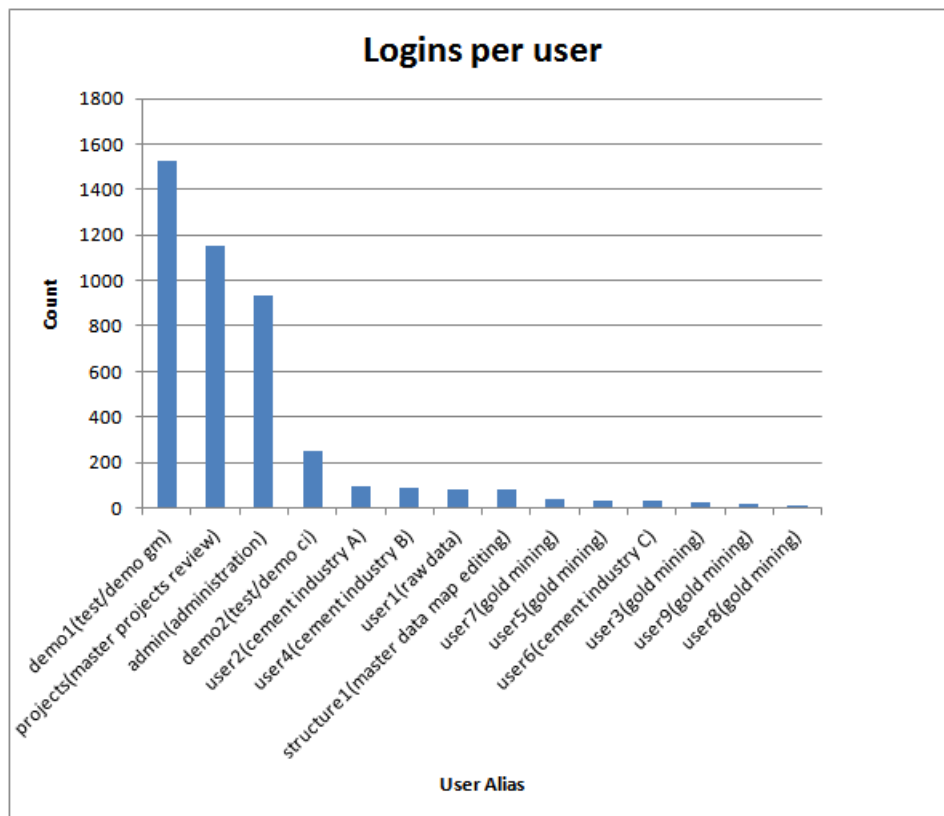

Figure 6.7: Logins - Analysis per system user

The higher login count from the cement industry personnel compared to that of the gold industry may be attributed to the fact that the personnel that have access to the system, have different focus areas in their job descriptions. The cement industry personnel are primarily on-site control personnel that needs to have access to the most recent data.

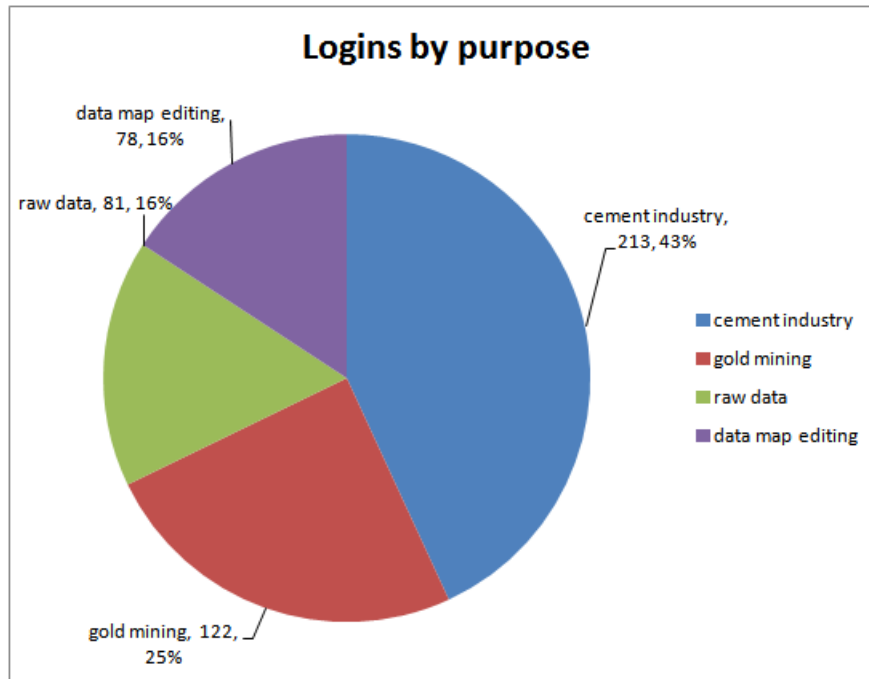

Figure 6.8: Logins - Analysis per purpose

In gold mining the focus, of the energy management services provided, is on company energy managers with between 50 and 100 sites or projects under their supervision that need aggregated data for internal and annual reports or budget allocation. There is thus a lower frequency of logins by management level personnel than there is for on-site instrumentation personnel. Figure 6.8 supports this argument. Users of the system are involved in projects that are rewarded with the cost savings benefits as they reach their savings targets. This can be partly attributed to the better communication and visibility provided by the interactive data mapping. Problems encountered can be identified and addressed since there exists a recurring flow of communication.

6.5 Verification and validation

In order to ensure a measure of quality control on the interactive data map's software the extent by which it addressed the specifications of Chapter 3.2 is evaluated through the verification and validation of each of these specifications. Table 6.6 indicates the specifications addressed.

Table 6.6: Verification of summarised specifications

Specification	Description	Addressed
1.(a)	A solution to the communication requirements in the industry.	✓
1.(b)	Utilises an interactive data map as a method of linking decision makers to the policy implementers.	✓
1.(c)	Provides a means to assign responsibility and facilitate communication between responsible personnel.	✓
1.(d)	support communication regarding energy efficiency and load shifting projects.	✓
1.(e)	functionality below provided.	✓
1.(e)i	Graphical navigation.	✓
1.(e)ii	Link and node management.	✓
1.(e)iii	Attribute value specification.	✓
1.(e)iv	Type specification.	✓
1.(e)v	Web-cam integration.	✓
1.(e)vi	File uploads and downloads.	✓
1.(e)vii	Integrated e-mail.	✓
1.(e)viii	Integrated SMS.	✓
1.(f)	Colour coded status indication.	✓
1.(f)i	Colouring is based on the predetermined defaults.	✓
1.(f)ii	Colour coding is based on the actual values of specific attributes and specific links between nodes.	✓
2.(a)	A tool for control.	✓

6.5. VERIFICATION AND VALIDATION

Specification	Description	Addressed
2.(b)	A tool for communication.	✓
2.(c)	A tool for policy compliance.	✓
3.(a)	Measured by quantitative means.	✓
3.(b)	Measured by qualitative means.	✓
4.(a)	Locationally accurate.	✓
4.(b)	Attributes should be given accurately for all nodes.	✓
4.(c)	Logically consistent.	✓
4.(d)	Complete with regard to the following two specifications.	✓
4.(d)i	Provides comprehensive data.	✓
4.(d)ii	Provides systematic ways of dealing with values.	✓
4.(e)	Supports lineage.	✓
5.(a)	Participation of multiple persons or systems collecting data.	✓
5.(a)i	Asynchronous access.	✓
5.(a)ii	Distributed setup.	✓
5.(b)	Attribute inaccuracy is correctable.	✓
5.(c)	Spatial inaccuracy is correctable.	✓
5.(d)	Acquired data is available immediately.	✓
5.(e)	Provision of a more detailed perspective.	✓
6.(a)	Lower depth level to see only a required portion.	✓
6.(b)	Higher depth level to make patterns visible.	✓
7.(a)	Data is translated from MySQL to XML and/or JSON.	✓
7.(b)	From user input to the database storage system.	✓
8.	Supports graphs of the directed acyclic type.	✓

The validation of the extent by which the various specifications are met is indicated in Table 6.7. It may be noted that all intended specifications are met with the required performance. Therefore the software artifact as a whole is successful with regard to meeting design specifications.

Table 6.7: Validation of specifications

Specification	Validation	%
1.(a)	Software is developed for the purpose indicated.	100
1.(b)	An interactive data map serves this purpose.	100
1.(c)	Responsibility can be assigned and mass communication is facilitated.	100
1.(d)	Communication with regard to the automated sending of reports for projects is performed.	100
1.(e)	Graphical navigation is supported through the mapped data.	100
1.(e)i	All of the required functionality is provided.	100
1.(e)ii	The data structure constructed from various links and nodes can be managed through interactive operations.	100
1.(e)iii	Additional attributes can be added and their values specified according to administrative design.	100
1.(e)iv	The type of nodes can be specified, e.g. DSM Project, Person, Board, etc.	100
1.(e)v	For taking profile photos of personnel, web-cam interaction is provided by the <i>Photo</i> field.	100
1.(e)vi	Files can be uploaded and downloaded for specified fields, such as the PDF field.	100
1.(e)vii	Mass e-mailing functionality is integrated into the data map allowing one to send e-mails to persons linked along communication channels running from a selected node.	100
1.(e)viii	In a similar way than the e-mails, SMSs can also be sent to groups of people.	100
1.(f)	Colouring of nodes and their labels in accordance to attributes having been set to specific values is supported.	100
1.(f)i	The colouring is based on the administrative predetermined defaults.	100
1.(f)ii	Specific links, such as a person linked to a technical role such as an Engineering Manager will render the person's node in blue according to administrable parent to child node colouring.	100
2.(a)	A good measure of control is attained by providing an overview of human resources and sending out of feedback with regard to projects.	100

6.5. VERIFICATION AND VALIDATION

Specification	Validation	%
2.(b)	Users are able to effectively use communication features of the interactive data map.	100
2.(c)	Mapping the requirements for standards compliance and providing visual feedback with regard to the status of ISO 50001 documentation the data map assists users in policy compliance.	100
3.(a)	The efficacy and capabilities of the interactive data map is measured both quantitatively, by looking at the counts of users and the performances of managed projects.	100
3.(b)	On a qualitative scale many of the capabilities are mentioned and even this validation serves to evaluate the degree by which the software had achieved addressing the various specifications.	100
4.(a)	Since editing of the data map is limited by user access rights, only specific people involved with company control structures and personnel can manipulate the data map to ensure that the nodes are connected correctly.	100
4.(b)	The attributes of each and every node can also only be edited by personnel provided with the appropriate editing access, to ensure that the values read in is as accurate as possible.	100
4.(c)	In order to ensure an over complex network of nodes, the structure is limited to the directed acyclic type. By providing specific design schemas a designer can easily build a network with a topology that equates to actual control structures.	100
4.(d)	The data map is complete with regard to the following two specifications.	100
4.(d)i	Comprehensive data is provided, both in the attributes of nodes, as well as in the reports that people, linked to the data map receive.	100
4.(d)ii	Systematic ways of dealing with values is provided through the administratively designed fields and default values as well as simple verification of the correctness of e-mails and mobile numbers.	100
4.(e)	Through intelligent map manipulation commands such as copy, cut, paste and merge a person can use historically created structures to build and extend the current structure or add to a new one without recreating everything each time.	100

6.5. VERIFICATION AND VALIDATION

Specification	Validation	%
5.(a)	Multiple persons accessing the data map simultaneously is supported.	100
5.(a)i	Users may asynchronously manipulate or view the data map.	100
5.(a)ii	These people may be located in various locations when accessing the centralised and web-based data map.	100
5.(b)	If attributes are inaccurate, persons with the required access levels is be able to correct these values.	100
5.(c)	The links of nodes linked incorrectly such as during the designing phase of a data map can be corrected through the "Break link" and "Copy" commands provided by the graphical user interface of the data map.	100
5.(d)	The changes and data added by one person is available to another once submitted through the web interface.	100
5.(e)	The high level data map show an overview of the various sources of data and provide links to this data. In depth billing data calculated information of projects and lower level instrumentation data are also available. This is provided through interactive links to users with the required access.	100
6.(a)	The level of depth viewed with regard to the amount of nodes that branch out from or branch into the selected node may be limited to ensure that Type I visualisation errors are mitigated.	100
6.(b)	By increasing the visible depth one may recognise additional structural links otherwise missed and thus Type II visualisation errors are mitigated.	100
7.(a)	Data is translated almost instantly from the SQL table storage into an XML format required by the visualisation component.	100
7.(b)	Data acquired from user input is effectively stored in the database and linked to the unique identifiers of the nodes, ready for retrieval once it is updated on the database.	100
8.	The data map supports the directed acyclic graph type and prevents cyclical patterns from being created by recursively checking the current state of the structure, before implementing operations and the user is warned of the limitations imposed.	100

6.6 Conclusive remarks

The client case study discussed three noteworthy projects and indicated the savings these projects achieved. This was brought into perspective with the purpose the interactive data map served with regard to the creation and maintenance of communication channels. The total number of projects and associated reports to date were also indicated.

The focus was then shifted to the use of the system for its various purposes. Associated results indicating higher use where the roles of the users are more involved in operation and maintenance were noted. The verification and validation of specifications were tabulated.

Chapter 7

Interpretation and Conclusion

7.1 Proposed enhancements

As mentioned in Chapter 3.3, it is necessary to implement new enhancements due to requests from clients and project engineers on a recurring basis.

One such a request, received from a project maintenance manager, consists of a daily overview of project performances with regard to reaching their respective targets as well as the availability of the most recent data streamed from the on-site control software. Additional developments with regard to smart software that detects reasons for communication failures and indicates periods of operating in specific modes of the on-site control software had been proposed.

The mapping of various downloadable software tools for the purpose of environmental, energy, and payback period calculations could also be effectively hosted on the EnMS with little effort.

7.2 Additional applications

This data map has a multitude of fields in which it can be applied. In various cases similar data map's are used in the analysis of criminal syndicates by security firms, the mapping of actors to the movies they played in and many others. Since this specific implementation of the data map has an administrative portal allowing the fine-tuning of available options and structure elements, it can, as it is, be used for any of the mentioned purposes.

The specific data map had found application in various fields. One of these is the depiction of the relations between stress, diet and exercise factors, human organs and blood glucose levels after a request by researchers in the medical field was pursued. There is extensive possibilities for family trees, because it supports the merging of nodes from differently rooted tree structures and will therefore be able to easily enable people to link their family trees along common ancestors.

One of the fine features it has is a search function that searches through all the attribute data in a current network. It allows instant navigation to the nodes that contain such data. Thus it may serve as a search engine through prior loaded data, or data that is added from various distributed locations and sources.

It is also used as a document storage system in parts of the EnMS, and has proven helpful in finding specific documents linked to specific sites. It exceeds the standard file system approach in the sense that it enforces specific structural naming conventions and colour coding that keeps the storage system less cluttered and chaotic as is the case in many electronic file systems.

7.3 Conclusion

From the declining capacity of the South African electricity grid discussed in Chapter 1.1 some reasoning might indicate the necessity of a South African public sector budget to be focused on constructing power stations. At the time of writing these are Kusile, Medupi as well as the Ingula pumped storage scheme. This had lead to some predominantly civil sector construction companies to evaluate strategies of becoming more involved in power provision due to the

lack of tender activity in other areas. The challenges for implementing lower carbon footprint solutions had certainly outweighed the immediate requirement for a sustainable grid for the decision makers of the day.

As indicated however, one cannot only focus on providing more power at such cost and keep increasing the carbon footprint. One should focus on allowing the sustainable growth of industries, especially to enable the prevention of the violent strikes, they are so prone to. One of these solutions is evidently the efficient use of the available power at existing industries and new developments. This can be managed through demand side projects.

For these projects to be able to show a measure of sustainable success, efficient communication was identified as one of the key factors that need to be addressed. This is in part done by this interactive data map as evident in Chapter 6.2 from the number of reports delivered to relevant personnel. As a human resources management tool it mitigates information overload as illustrated in Chapter 5.2 through providing managers with an abstraction layer. This may in turn lead to a better managed "complexity profile," mentioned in Chapter 2.11, in the correlated social corporations that manage the mining and manufacturing industries.

Even though this data map provides a service to but a fraction of the projects and energy management practitioners in the South African context, it does provide interesting insights at the design level. Especially with regard to designing with reliability and scalability. It involves various code artifacts developed by a team of engineers and third parties, noted in Chapter 4.3 and integrated them to provide a compact solution to satisfy the specifications in Chapter 3.2 as verified and validated in Chapter 6.5.

Thus, although there may be some features and optimisations that can be implemented on the software it is not only conceptually, but also a practical success. Industrial energy management can be effectively done through interactive data mapping.

Bibliography

- [1] C. Bullock, G. Caraghair. *Guide to energy services companies* [Electronic Book]. The Fairmont P, Inc., 2001. [On-line] <http://books.google.com>.
- [2] Eskom. *Communication Report[s] [1586-2122]*. ©Eskom (Pty) Ltd, Hvac International (Pty) Ltd, 2011-2012. [Electronically aggregated data]. 536 x 1p.
- [3] MetroGIS. "**Proposed Karoshoek Solar valley development**". ©MetroGIS (Pty) Ltd, Savannah Environmental (Pty) Ltd. FG Emvelo (Pty) Ltd, June 2010. [Visual Impact Assessment]. 65p. [On-line] <http://www.savannahsa.com/documents/3870/Appendix%20I%20Visual%20study.pdf>.
- [4] Eskom Generation Communication. "**Pumped storage hydroelectric schemes and water transfer**". ©Eskom (Pty) Ltd, August 2010. [Fact sheet]. 65p. [On-line] http://www.eskom.co.za/content/HY_0001PumpStorSchWaterTrRev3~1~1.pdf.
- [5] CIPEC¹. *Energy efficiency planning and management guide* [Virtual library book]. ©Her Majesty the Queen in Right of Canada, 2002, ISBN 0-662-31457-3, p. 20. [On-line] <http://oee.nrcan.gc.ca/infosource>.
- [6] Leadership Institute. "**Who is Dr. W. Edwards Deming?**" [Web Document]. ©1996-2001 by Leadership Institute, Inc. [On-line] <http://www.lii.net/deming.html>.
- [7] O. Hearne. "**S&E Regional OP 2007 - 2013, Draft Implementation Plan 2.2.2**" [Draft] SEAI² Oct 2009, 4p. [On-line] <http://www.seregassembly.ie/docs/EnergyBusiness.pdf>.

¹CIPEC: Canadian Industry Program for Energy Conservation.

²SEAI: Sustainable Energy Authority of Ireland.

-
- [8] ITU-T. *Information technology – Open Systems Interconnection – Procedures for the operation of OSI Registration Authorities: Generation and registration of Universally Unique Identifiers (UUIDs) and their use as ASN.1³ object identifier components*. ITU-T⁴ Recommendation X.667, Approved 29 Aug 2008, p. 7. [On-line] http://www.itu.int/rec/dologin_pub.asp?lang=e&id=T-REC-X.667-200808-I!!PDF-E&type=items.
- [9] A.M. MacEachren. "**Visualizing uncertain information.**" [Article]. *Journal of Cartographic Perspective*, vol. 13, pp. 10-19, 1992.
- [10] S.Benford, J. Mariani. "**Virtual environments for data sharing and visualisation - Populated information terrains**". ©University of Lancaster, 1994. [Research report]. 13p. [On-line] http://reference.kfupm.edu.sa/content/v/i/virtual_environments_for_data_sharing_an_98005.pdf.
- [11] R. Krishnamurthy, V.T. Chakaravarthy, R. Kaushik, J.F. Naughton. "**Recursive XML schemas, recursive XML queries, and relational storage: XML-to-SQL query translation**" [Paper] *University of Wisconsin-Madison* 12p., 2004. [On-line] http://www.csd.uoc.gr/~hy561/Data/Papers/sekar_icde04.pdf.
- [12] R. Krishnamurthy, R. Kaushik, and J.F. Naughton. "**XML-to-SQL query translation literature: the state of the art and open problems**" [Paper] *University of Wisconsin-Madison* 17p., 2003. [On-line] <http://homepages.inf.ed.ac.uk/wenfei/qsx/reading/xmltosqlsurvey.pdf>.
- [13] A. Gupta, M.R. Tennefoss. *Radio frequency control networking: why poor reliability today hampers what could be a viable technology in the future* [Book]. ©2005 by Echelon Corporation. [On-line] http://www.echelon.com/support/documentation/analysis/005-0171A_RF_White_Paper.pdf.

³ASN.1: Abstract Syntax Notation One: Used by ISO.

⁴ITU-T: Telecommunication standardisation sector of ITU.

-
- [14] D.J. Cook, L.B. Holder. "**Graph-based data mining.**" [Article]. *Journal of Intelligent Systems and their Applications*, IEEE, vol. 15:2, pp. 32-41, Apr 2000. ISSN: 1094-7167. [On-line] http://ieeexplore.ieee.org/xpl/freeabs_all.jsp?arnumber=850825,digitally-sign-a-macro-project-HA001231781.aspx.htm.
- [15] B. Burkhard, F. Kroll. "**Maps of ecosystem services - supply and demand.**", Feb 2010. [Article]. [On-line] http://www.uni-kiel.de/ecology/projects/salzau/wp-content/uploads/2010/02/Background-Paper-Burkhard_Kroll.pdf.
- [16] M. Ayers. "**DOE Data Explorer: The Data.**", Sep 2008. [Web Article]. [On-line] <http://www.istl.org/08-fall/electronic.html>.
- [17] I. Verbauwheide, P. Schaumont. "**Smart Grid, Security and EDA.**" [PDF Presentation]. K.U. Leuven, UCLA, Jun 2010. [On-line] <http://www.datc.info/Smartpower/smartpower2010/14-IngridVerbauwheide.pdf>.
- [18] S. Mitchell, P. Clair. "**Stuxnet: anatomy of a computer virus**". *Zapruder's Other Films, Australian television (ABC1 - HungryBeast)*, 2011. [Video presentation]. <http://vimeo.com/25118844>.
- [19] V. Kamlyuk, Anon. "**'Flame' Virus explained: How it works and who's behind it**". *RT News*, 29 May 2012, 23:58. [Online news dialogue] <http://www.rt.com/news/flame-virus-cyber-war-536/>.
- [20] A.L. de A.P. Zuquim, et al. "**Efficient power management in real-time embedded systems.**" [Article]. *Cartographic Perspective*, vol. 13, pp. 10-19, 1992. [On-line] <http://citeseerx.ist.psu.edu/viewdoc/download?doi=10.1.1.83.2551&rep=rep1&type=pdf>.
- [21] J.N. du Plessis. "**Development of an energy management solution for mine compressor systems**". *North-West University, CRCED*, Nov 2010. [Masters Thesis]. 70p.
-

-
- [22] J.F. van Rensburg. "**Developing ESCo procedures for large telecommunication facilities using novel simulation techniques**". *North-West University, CRCED*, Jan 2006. [PhD Thesis]. pp. 161-162.
- [23] A. Campagnoni, M. Carta. "**Mapping Environmental Risk by Application of GIS Technologies in the Southern Part of Venice Province.**", 27 Jul 1999. [Article]. [On-line] <http://www.ces.iisc.ernet.in/energy/HC270799/LM/SUSLUP/Thema5/755/755.pdf>.
- [24] P. Napolitano, A.G. Fabbri. *Single-parameter sensitivity analysis for aquifer vulnerability assessment using DRASTIC and SINTACS* [Proceedings of the Vienna Conference, April 1996]. IAHS Publ. no. 235, 1996. [On-line] http://iahs.info/redbooks/a235/iahs_235_0559.pdf.
- [25] J. Uhan, J. Pezdič, M. imo Civita. "**Assessing groundwater vulnerability by SINTACS method in the Lower Savinja Valley, Slovenia.**" *Journal of Materials and Geoenvironment*, vol. 55:3, pp. 363-376, 2008. [On-line] http://www.rmz-mg.com/letniki/rmz55/RMZ55_0363-0376.pdf.
- [26] X. Liu. "**A super data-sharing model in common platform of geographic information.**" [Article]. *Journal of Software*, vol. 6:7, Jul 2011. [On-line] <http://ojs.academypublisher.com/index.php/jsw/article/download/jsw060711741180/3310>.
- [27] K. Gaofeng, L. Zhongzheng, L. She, J. Moushun. "**Application of remote sensing technology in coal resource exploitation monitoring and management.**" [Article]. *Journal of Coal Geology of China*, Jan 2008. [On-line] http://en.cnki.com.cn/Article_en/CJFDTOTAL-ZGMT200801007.htm.
- [28] M.G. Meyer, D.B. McIndoe. "**Personnel risk management system and methods.**" [Patent]. *Patent US2005/0182722 A1*, 18 Aug 2005. [On-line] <http://www.freepatentsonline.com/y2005/0182722.html>.
-

-
- [29] F. Ying-lan, H. Bing. "**Design and implementation of ETL management tool.**" [Article]. *KAM*, vol. 1, pp.446-449, 2009 Second International Symposium on Knowledge Acquisition and Modelling, 2009. [On-line] <http://doi.ieeecomputersociety.org/10.1109/KAM.2009.105>. ISBN: 978-0-7695-3888-4.
- [30] L.S. Hand, J.R. Washburn. "**Method and apparatus for replaying and visualizing post-performance metrics for a complex heterogeneous data space.**", 2002. [Patent]. *Patent application US2002/0177907 A1*, [On-line] <http://www.freepatentsonline.com/y2002/0177907.html>.
- [31] T. Li. "**XML sata mapping under SAS 9 - from the perspective of electronic submissions.**" [Article]. Merck & Co., Inc., Rahway, NJ, 2004. [On-line] <http://www.lexjansen.com/pharmasug/2004/fda-compliance/fc01.pdf>.
- [32] D. Massengill. "**SAS Mapping: technologies, techniques, tips and tricks.**", Mar 2003. [Paper]. [On-line] <http://support.sas.com/rnd/papers/sugi28/SASMapping.pdf>.
- [33] S.B. Droege. "**Management control**" [Encyclopedia Article] *Encyclopedia of Business*, 2nd ed. ©2012 Advameg, Inc. [On-line] <http://www.referenceforbusiness.com/management/Log-Mar/Management-Control.html>.
- [34] M.J. Cameron. "**Policy analysis in South Africa with regional applied general equilibrium models**" [Thesis (M. Com. (Economics))] *North-West University, Potchefstroom Campus*, 2008. [On-line] <http://hdl.handle.net/10394/2024>.
- [35] J. Rust. "**Dealing with the complexity of economic calculations**" [Working Paper] *Yale University* 1997. [On-line] <http://citeseerx.ist.psu.edu/viewdoc/download?doi=10.1.1.34.4966&rep=rep1&type=pdf>.
-

- [36] Z. Iqbal, R. Siddiqui. "**Critical review of literature on computable general equilibrium models**" *MIMAP technical paper series* vol. 9, Jan 2001, 25p. ISBN 969-461-105-9. [On-line] <http://web.idrc.ca/uploads/user-S/10282059170mimap37.pdf>.
- [37] Thales Research and Technology (UK) Limited. "**The UK civilian command and control hierarchy for crisis management - responsibilities and information flow**" [White Paper] © *Thales Research and Technology (UK) Limited*, 2008. [On-line] <http://www.thalesresearch.com/Publications/WhitePapers/Documents/EDE080101.pdf>.
- [38] Y. Bar-Yam. "**Complexity rising: from human beings to human civilization, a complexity profile**" [Article] © *Encyclopedia of Life Support Systems*, EOLSS UNESCO Publishers, Oxford, UK, 2002 [and also] *NECSI Report*, Dec 1997. [On-line] <http://www.necsi.edu/projects/yaneer/EOLSSComplexityRising.pdf>.
- [39] J. Husband. "**From hierarchy to wirearchy - the future of workplace dynamics.**", ©World Future Society, 2001. [WEB Article]. Cyber Society Forum. [On-line] <http://www.wfs.org/husband.htm>.
- [40] S. Jobs. "**Thoughts on Flash**". ©2012 Apple Inc., Apr 2010. [Online News Article]. <http://www.apple.com/hotnews/thoughts-on-flash/>.

Addendum A

This addendum contains a set of screen shots that illustrate functionality provided by the interactive data map. This includes an in depth discussion as noted in Chapter 4.4.

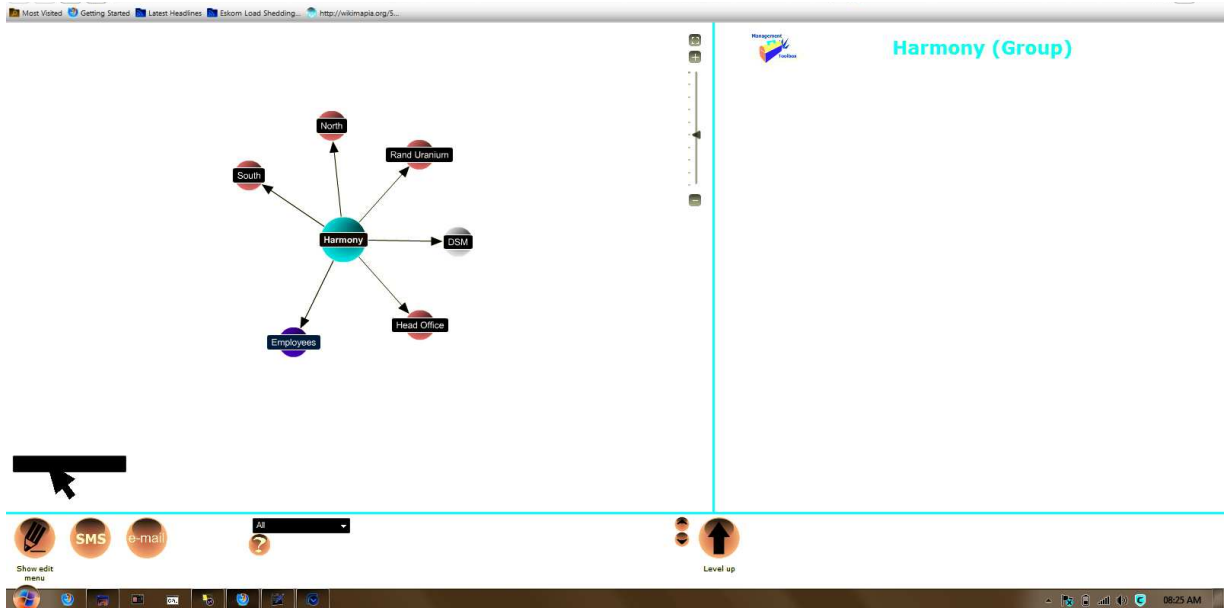

Figure A.1: User interface frame 1

The procedure of linking an existing node that represents a project engineer to another project is demonstrated. This is done in order that this engineer might receive the required DSM reports delivered to him on a monthly and weekly basis.

First of all let one suppose that there is knowledge of an existing engineer receiving reports for a project at hand. His name is Oswald van Ginkel. In Figure A.1 one clicks in order that one might enter the first few letters of ones name in Figure A.2. Pressing the client computer's return key upon entering the letters "Osw" one is returned the search result as in Figure A.3.

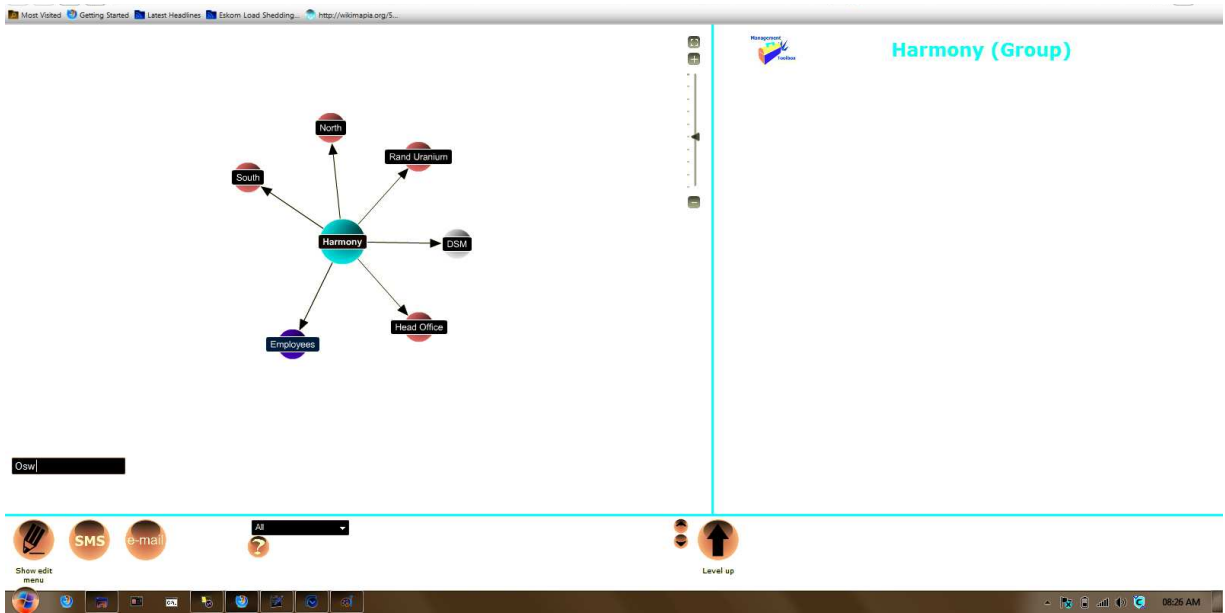

Figure A.2: User interface frame 2

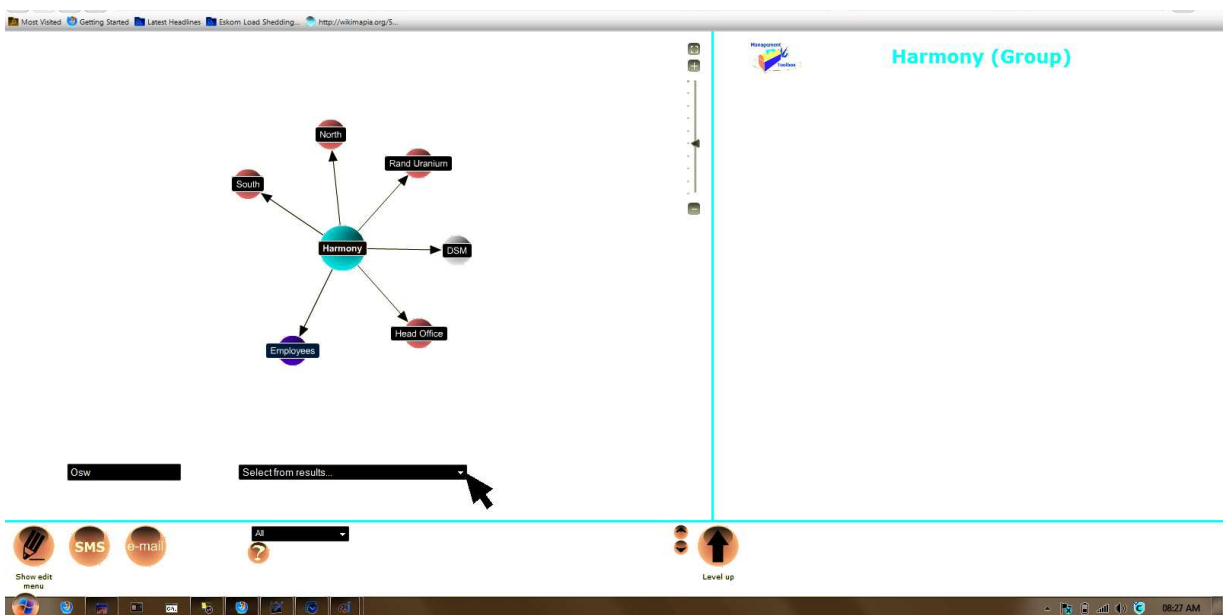

Figure A.3: User interface frame 3

One can now commence by selecting from the set of results. In this particular case only a single result for the person called Oswald van Ginkel can be clicked with the client computer's

mouse. Upon clicking in Figure A.4, the structure for the Harmony group in *Skynet Viewport* automatically navigates to the specified person's node in Figure A.5. The profile data associated with the person is also displayed in *Skynet submit* situated on the right hand side of Figure A.5.

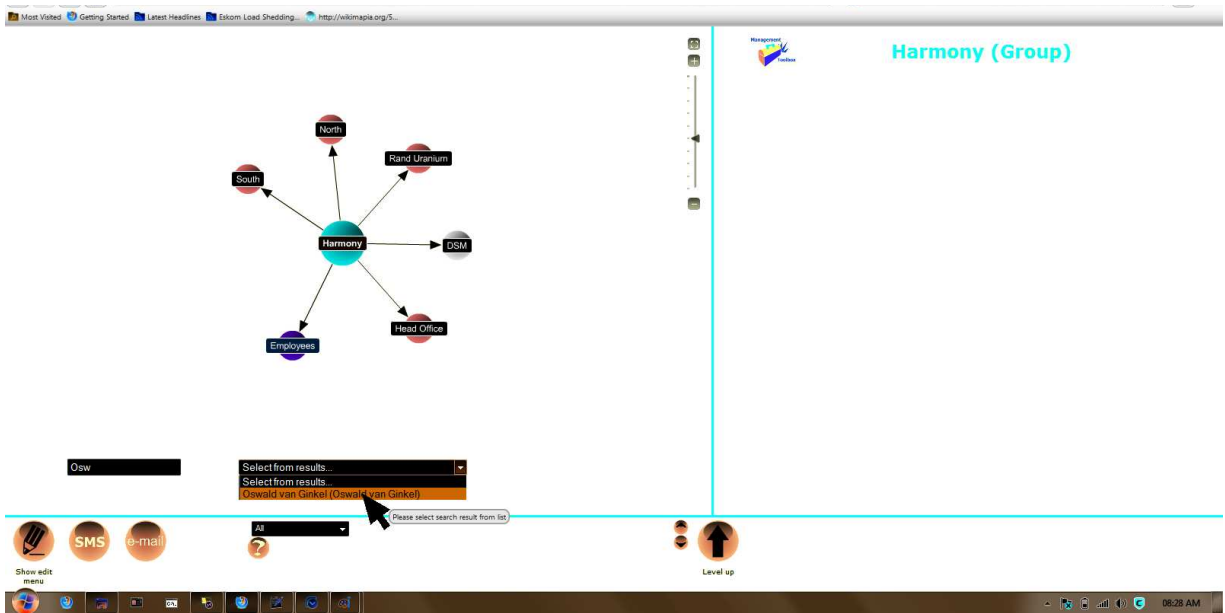

Figure A.4: User interface frame 4

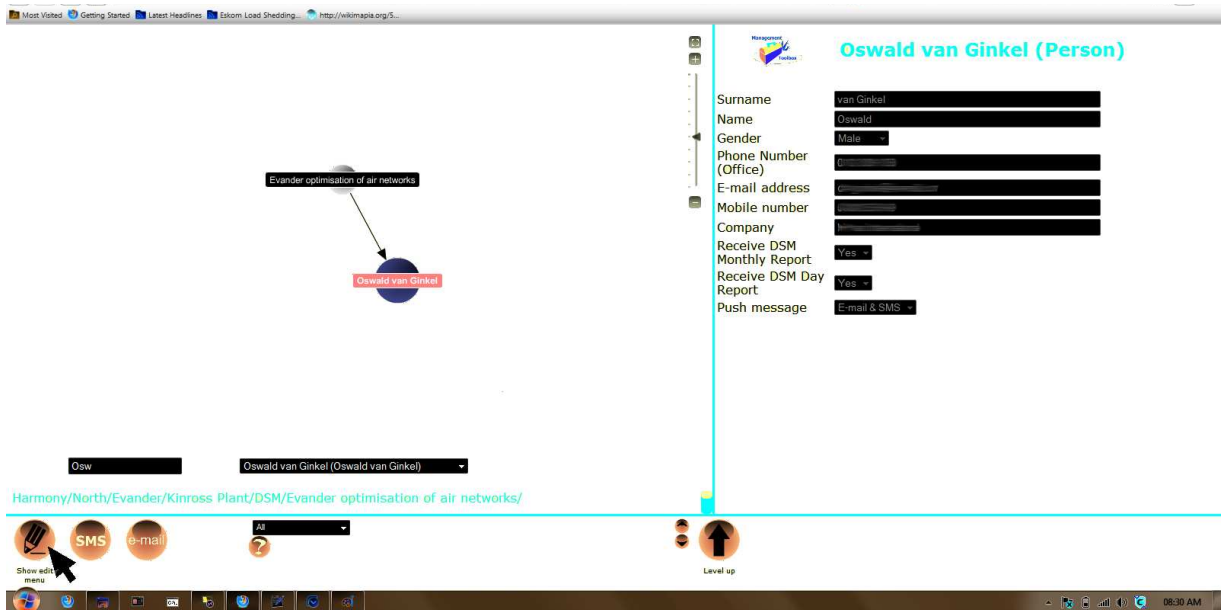

Figure A.5: User interface frame 5

If one requires that this person only receives monthly reports and not daily reports, one will need to edit his profile data. Since one is logged in as a user with the privilege to edit one can toggle the current mode, "view mode," to "edit mode" by clicking on the leftmost button on the bottom *Skyenet Control* bar. This brings one to Figure A.6 where one may now change the value of the field "Receive DSM Day Report" to the other option "No" in Figure A.7.

Note that each of these fields, e.g. "Gender" and "Push message," that can be associated with a node of the person type were specified from the administrative portal. Also each and every option, such as the "Yes" or "No" for receiving reports or the "Male" and "Female" for specifying the gender of a person was also uniquely associated to be available for their respective fields. The user acting in "edit mode" has the ability to remove any fields already associated with the current node with the dust bin icon buttons. The user might also add fields from a list available to the specific type of node with the "Add data field" button.

Therefore none of the data displayed is hardcoded⁵. This may be seen as a continuation of the design pattern. Options are totally customisable from an administrator's perspective and selections and data entry is dealt with by the user. Specific background functionality, associated with selections such as receiving reports, is the responsibility of the code developer.

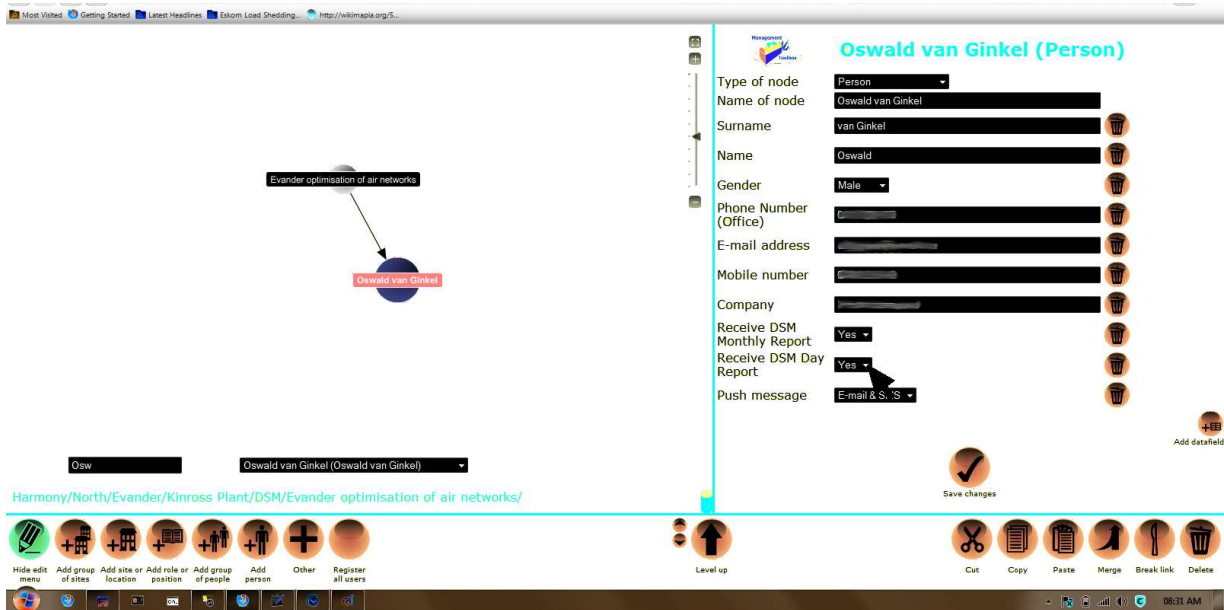

Figure A.6: User interface frame 6

⁵Hardcoded: Coding where configuration data is effectively coded into the source of a software project.

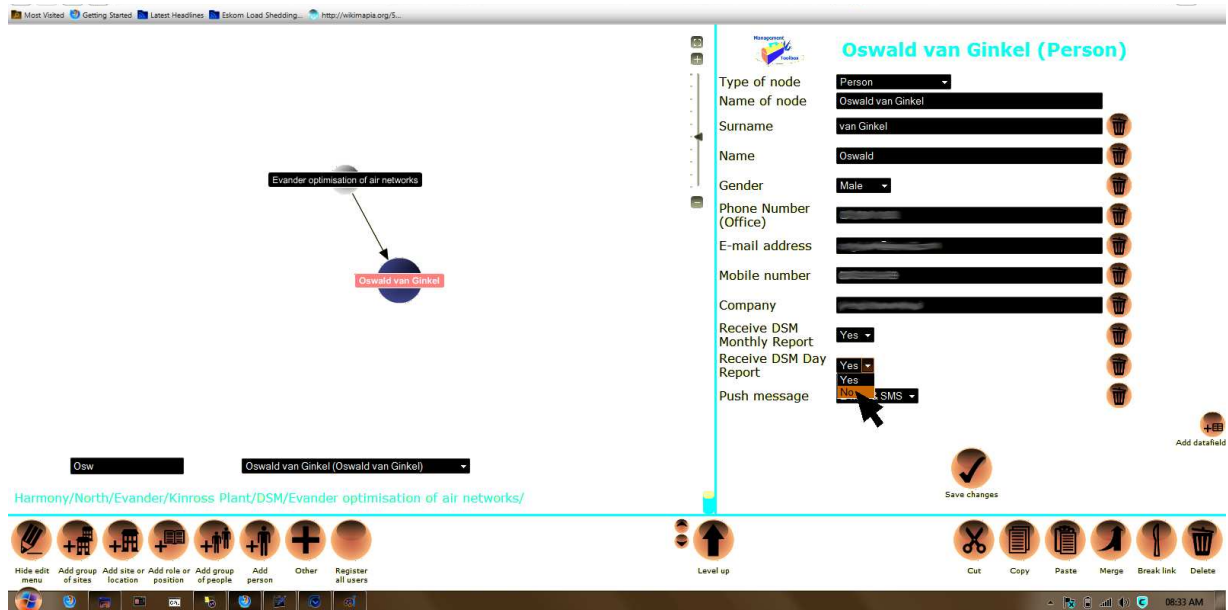

Figure A.7: User interface frame 7

One may now be satisfied that Oswald van Ginkel will not be receiving the daily reports for the Evander optimisation of air networks project in future. The illustration of linking another engineer, who will receive both daily and monthly reports, to this project will now continue. One can interactively navigate through the structure, for instance clicking on the node of the Evander project in Figure A.8.

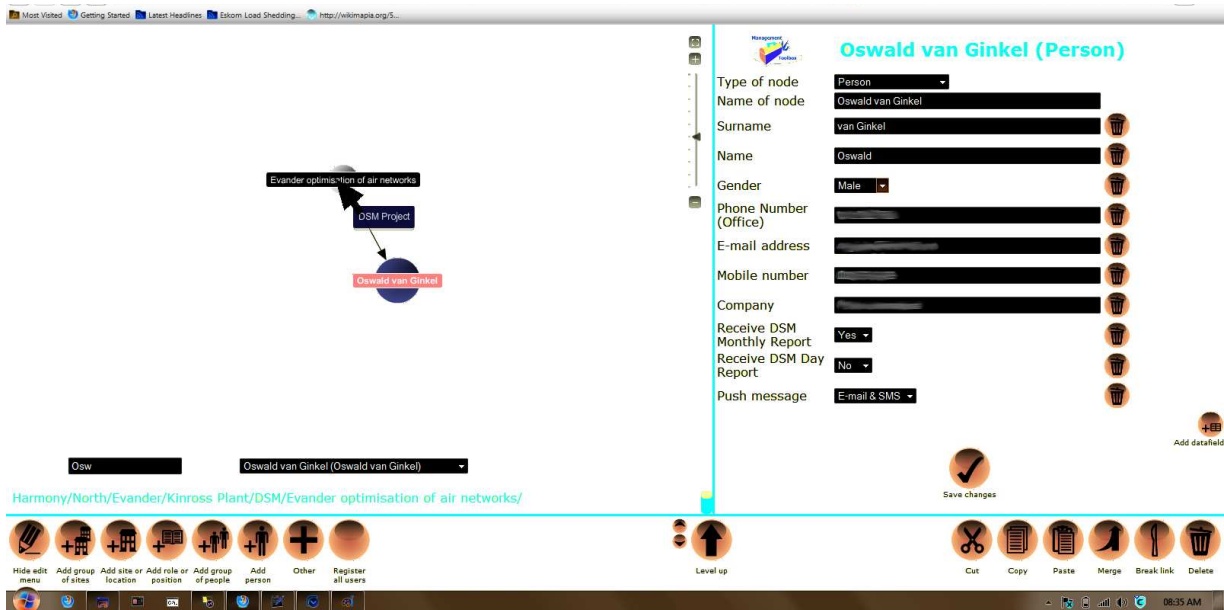

Figure A.8: User interface frame 8

This loads the appropriate details in Figure A.9. Along this route one might consider going all the way to the root node of the networked structure by iteratively clicking the "Level up" button at the centre of *Skynet Control*. This node is reached in the graph in Figure A.10. Now a manually top down approach, in searching for the project engineer associated with the Evander 8 shaft pumping project, can be performed. One may thus start by clicking on the DSM node, and then clicking on the project's node in Figure A.11. This would lead to Mr. Nortje in Figure A.12.

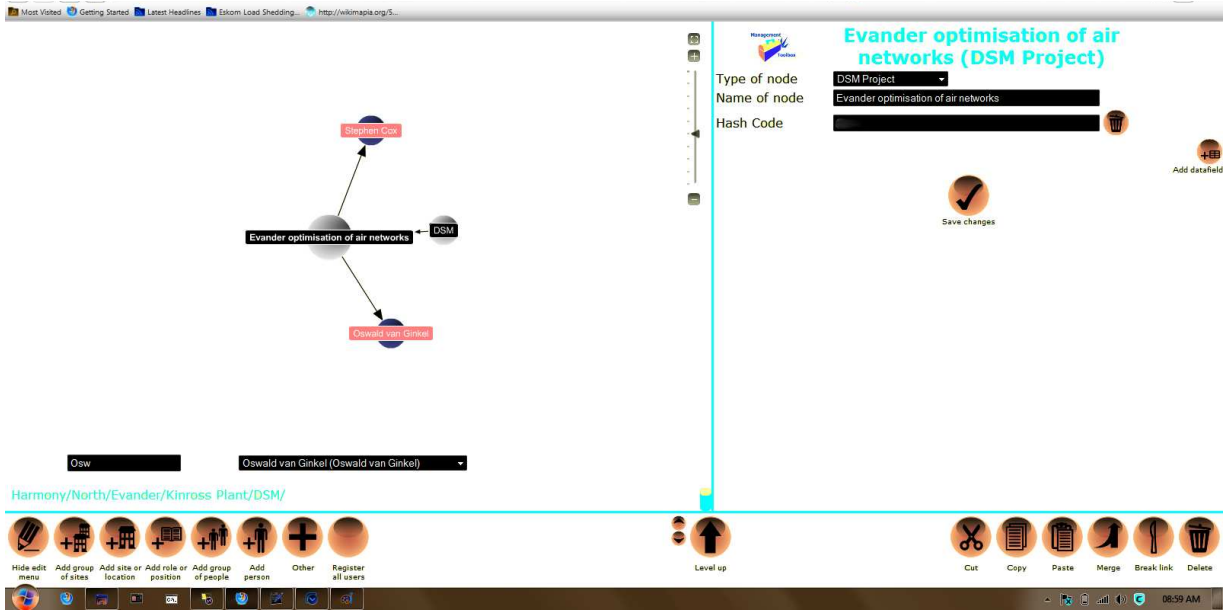

Figure A.9: User interface frame 9

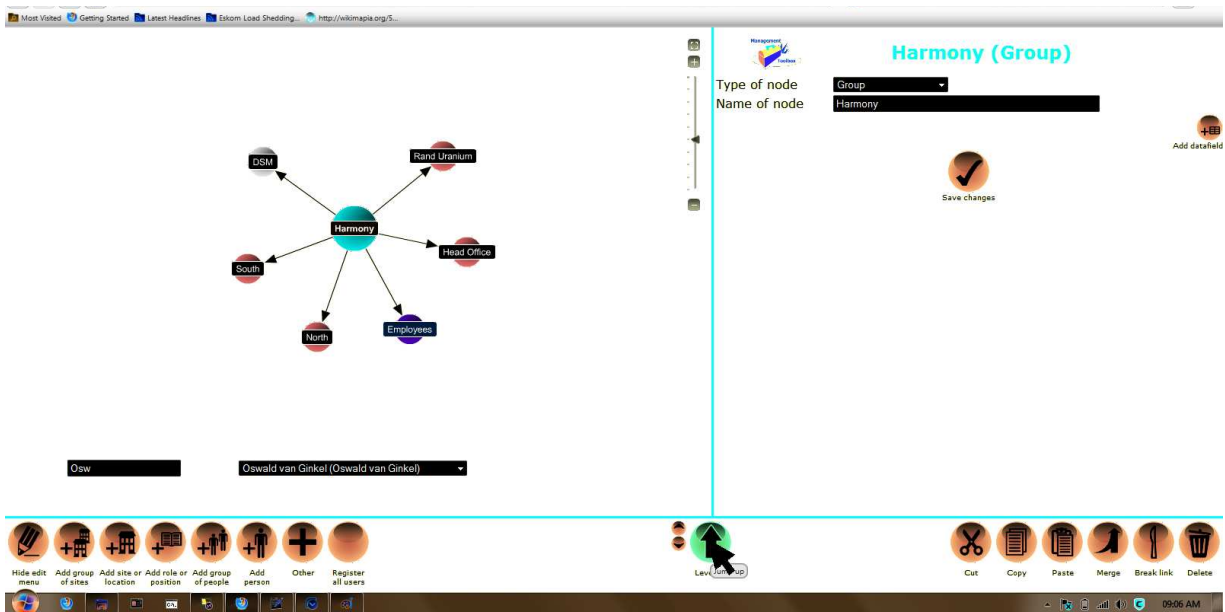

Figure A.10: User interface frame 10

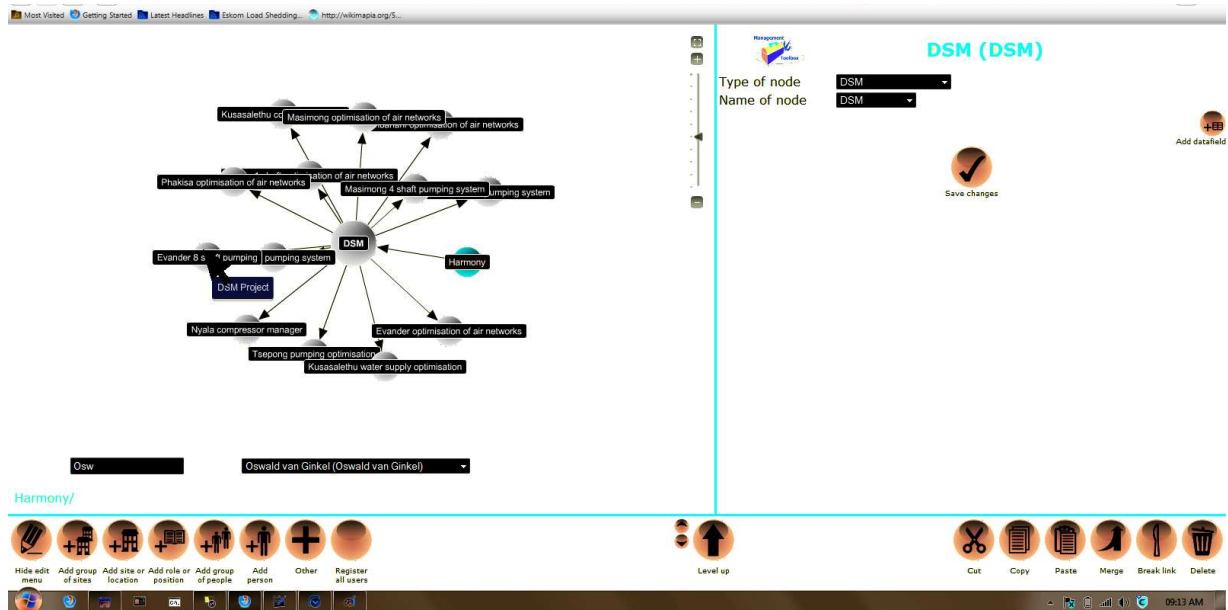

Figure A.11: User interface frame 11

To link him one clicks the "Copy" button of Figure A.12 and on the prompt one selects the option to link, rather than to duplicate, his node in Figure A.13. One might navigate through the "Level up" in Figure A.14 and reach the DSM node again in Figure A.15. From here one can easily access all DSM projects, especially the required Evander optimisation of air networks project in Figure A.16 which is clicked to reach Figure A.17.

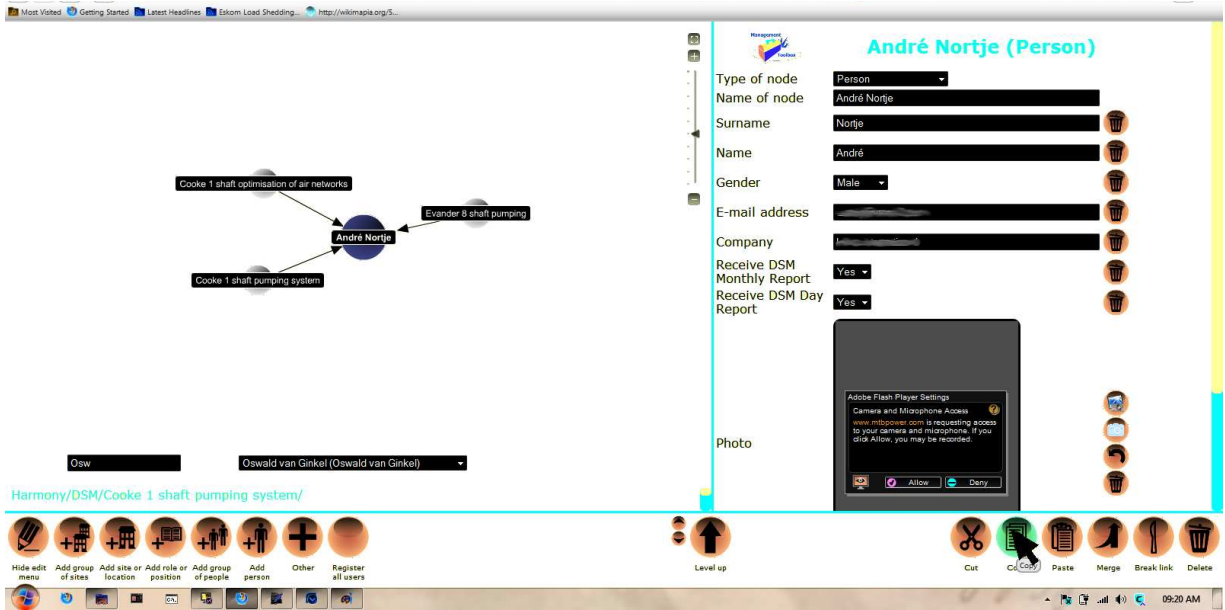

Figure A.12: User interface frame 12

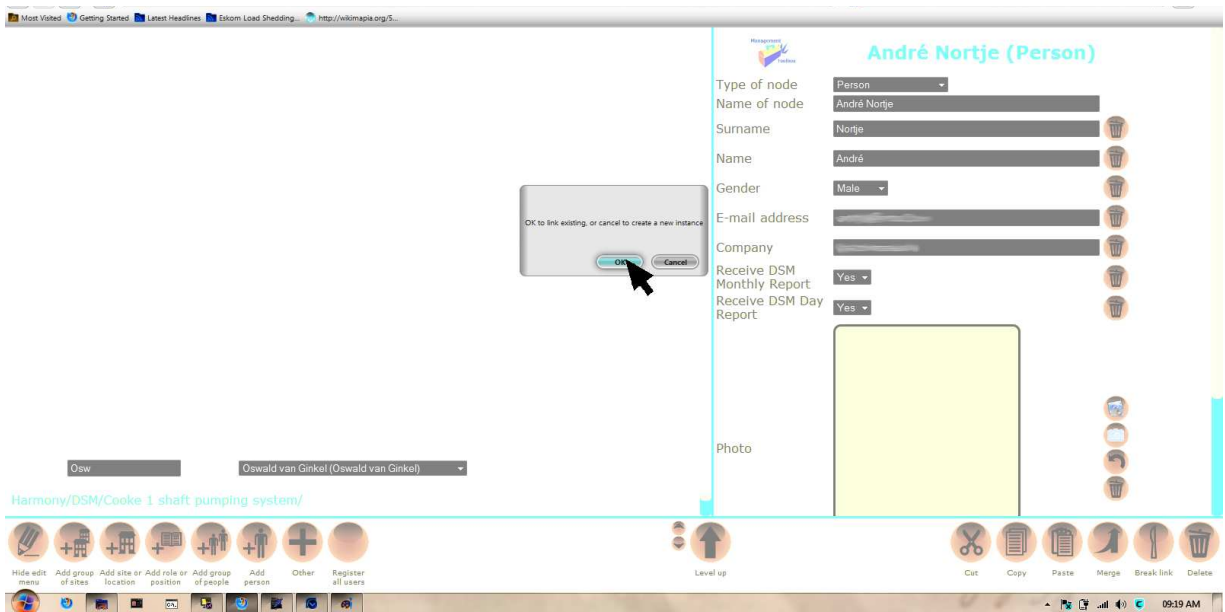

Figure A.13: User interface frame 13

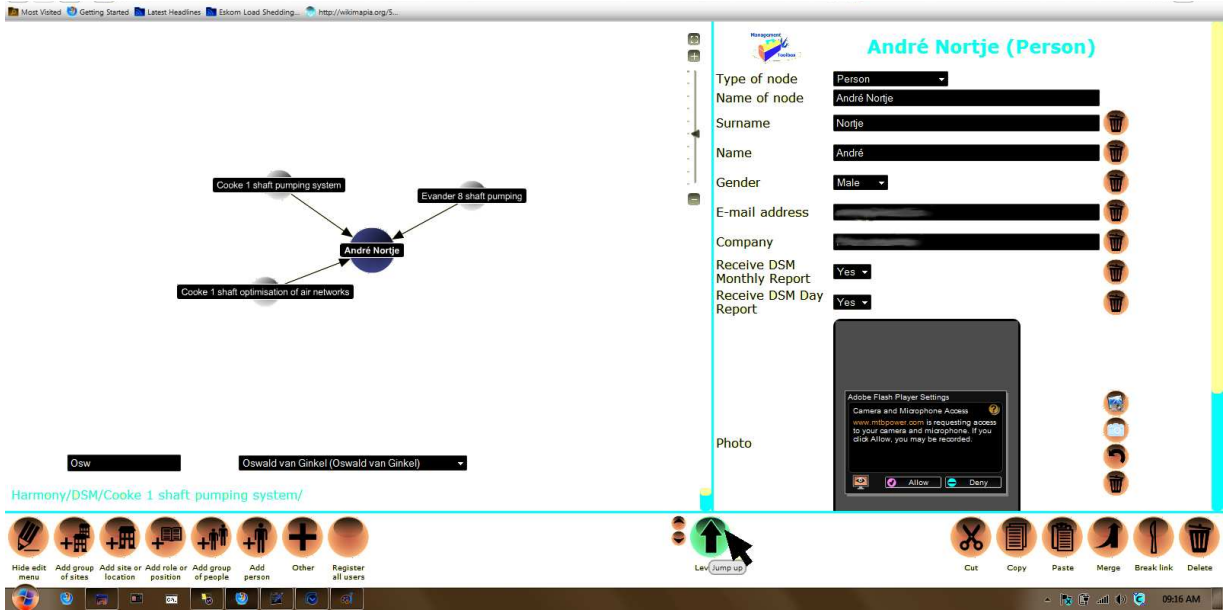

Figure A.14: User interface frame 14

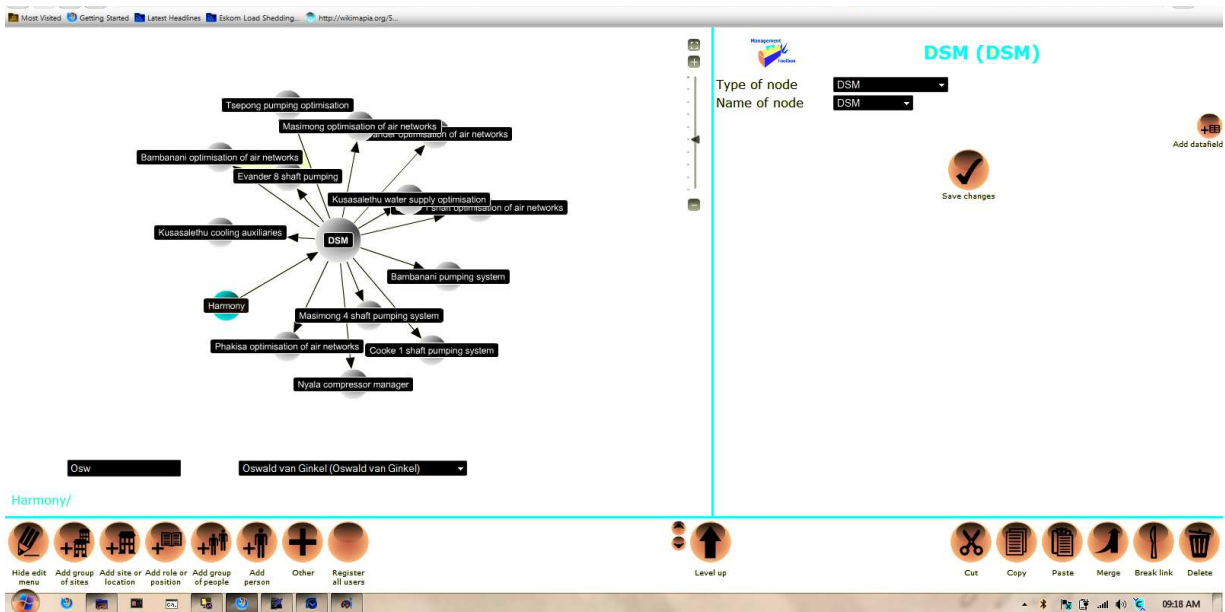

Figure A.15: User interface frame 15

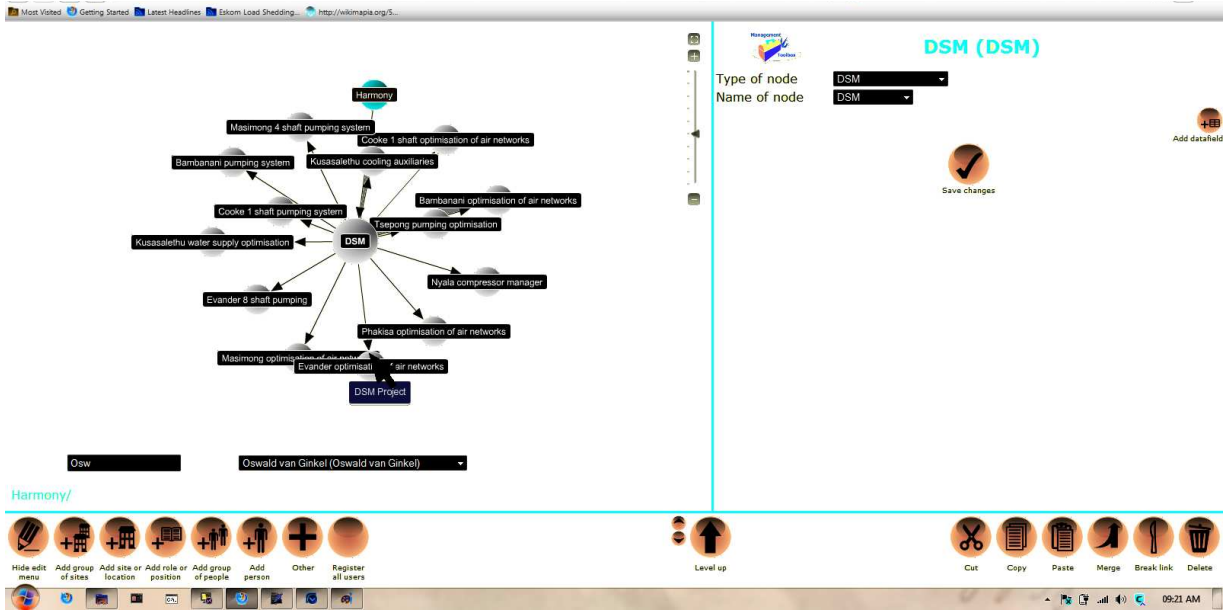

Figure A.16: User interface frame 16

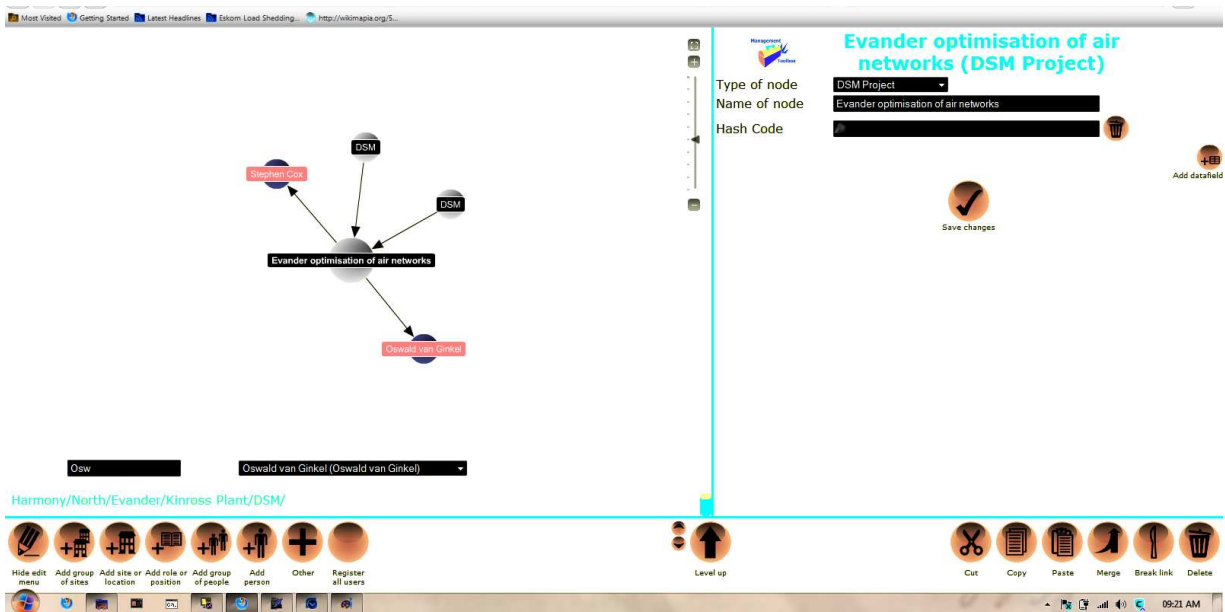

Figure A.17: User interface frame 17

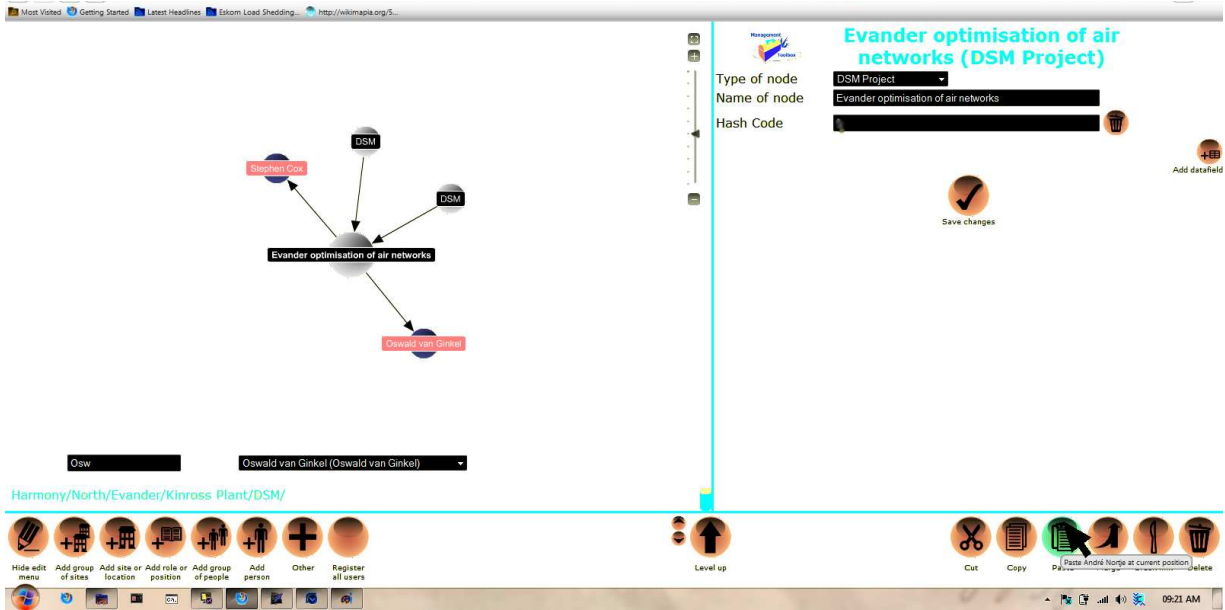

Figure A.18: User interface frame 18

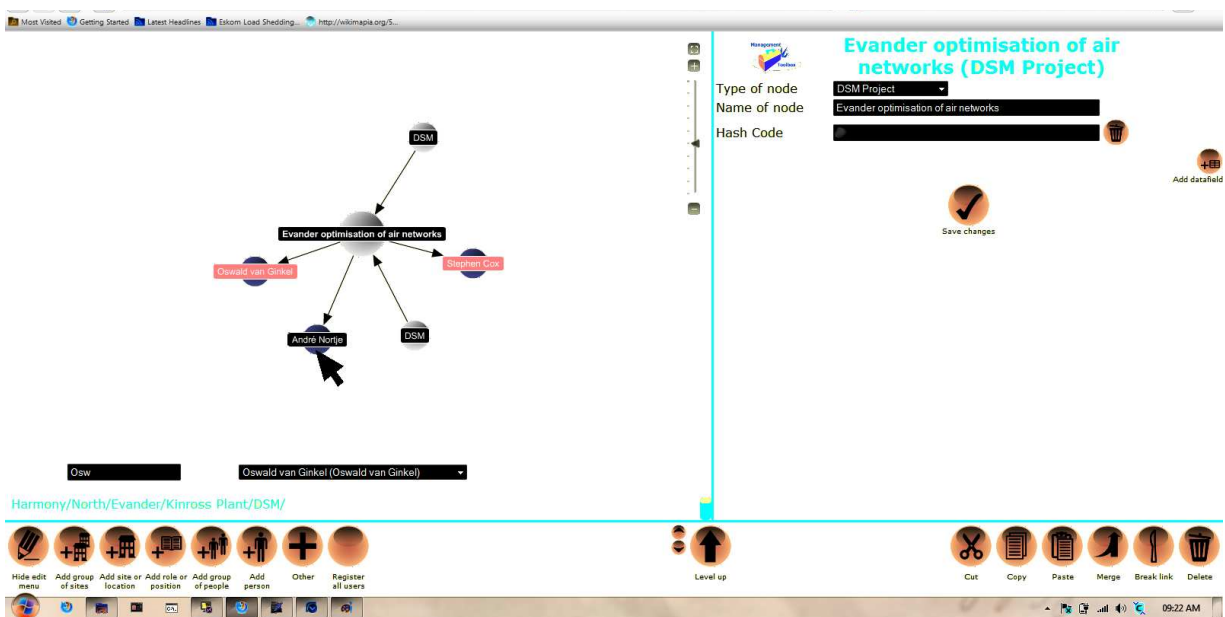

Figure A.19: User interface frame 19

At this project's node the "Paste" command is performed and André Nortje is effectively linked to this project in Figure A.19. In summary he will receive all reports for the projects he

is linked to as the directional arrows indicate in Figure A.20. Since the interface is set to edit mode the taking of a picture through a web camera is presented as an option for the "Photo" field.

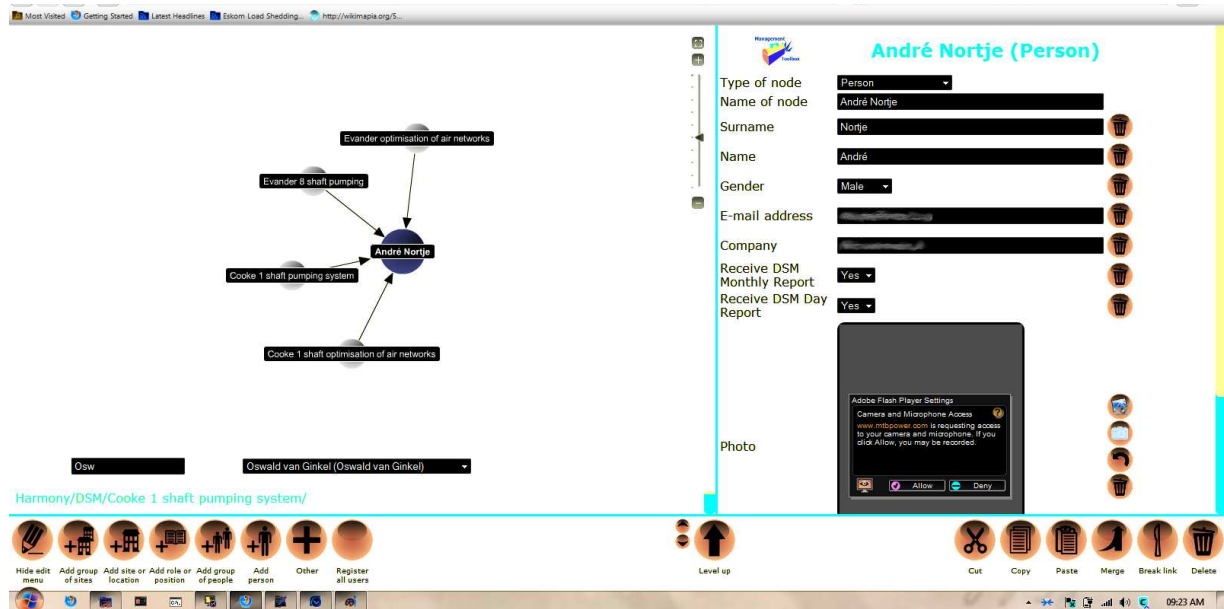

Figure A.20: User interface frame 20

The screen shot of Figure A.21 illustrates the ability to instantly send a focused group SMS to alert electrical foremen of imminent load shedding that may negatively affect operations.

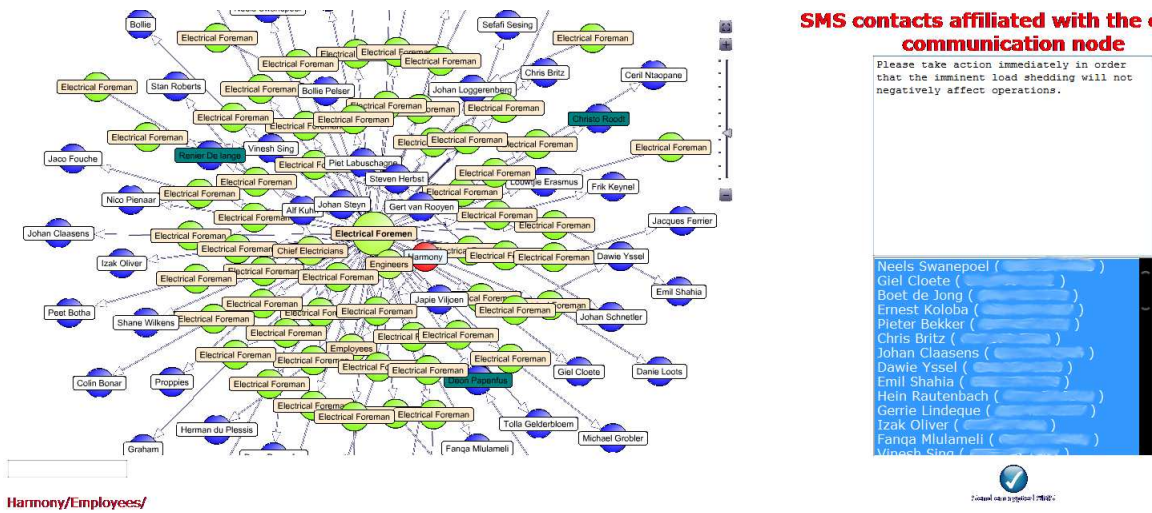

Figure A.21: User interface frame 21