

COMPUTER ENGINEERING IN A CHANGING WORLD

Prof Willie Venter



HUMBLE BEGININGS



IN THE INDUSTRY

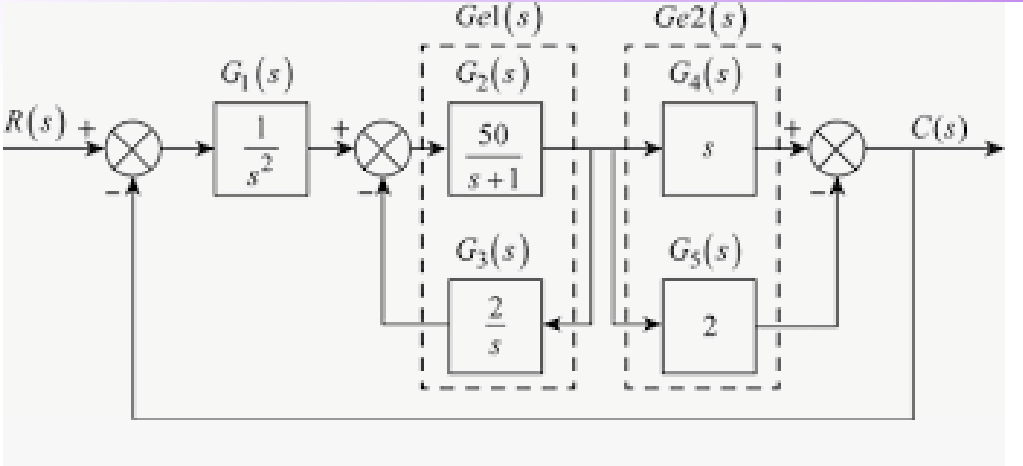



IOWA STATE



COMPUTER ENGINEERING

- Definition of an engineer
- Types of engineers such as
 - Electrical engineers
 - Electronic engineers
 - Mechanical engineers
 - Chemical engineers
 - Industrial engineers
 - Computer engineers
- What is a computer engineer?
- What is computer technology?
 - Hardware
 - Software
 - Algorithm development

EXAMPLES OF COMPUTER ENGINEERING PROBLEMS:

- Audio Advertisement detection
- Video Advertisement detection
- Transportation optimization

ADVERTISEMENT DETECTION COST OF ADVERTISING SUPERBOWL 2019



- Audience: 98.2 million
- Average price: US\$ 5.2 million (R72 800 000.00) per 30 sec slot
- That means over US\$ 170 000.00 (R2.5 million) per second

ADVERTISING PROBLEMS

Markets lose “millions” in lost advertisement flightings:

- Ornico identified an flighting error rate of up to 11%
- Errors that occur:
 - An advertisement was not at all broadcasted
 - An advertisement was broadcasted at an incorrect time
 - An advertisement was broadcasted directly before or after a competitor’s advertisement
- Objective:
 - Develop systems to automatically detect advertisements broadcasted on radio and television

AUTOMATIC ADVERTISEMENT DETECTION

How to approach this problem - go back to basic principles:

- Humans can be identified by fingerprints

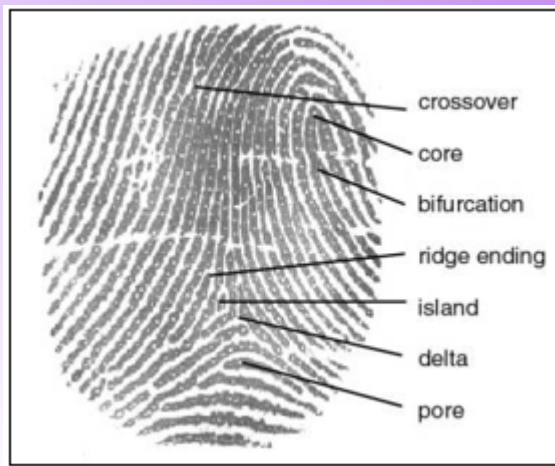

- This fingerprint can be identified by using pattern recognition principles



AUTOMATIC ADVERTISEMENT DETECTION

- **Question:** Can a similar technique be used for advertisement detection?
- **Problem:** advertisements do not have fingerprints
- **Solution:** use computer engineering to develop an algorithm to generate fingerprints for advertisements
- **Tools:** digital signal processing and software development

AUTOMATIC ADVERTISEMENT DETECTION

System Learning:

- Record incoming radio or TV signal
- Manually identify advertisements in the recorded signal
- Generate fingerprints of identified advertisements
- Store fingerprints in database

Advertisement Detection:

- Record new incoming radio or TV signal
- Continually generate fingerprints from recorded signal
- Compare generated fingerprints with fingerprints in database
- Identify advertisement based on fingerprint comparison

AUDIO ADVERTISEMENT DETECTION

Audio fingerprint generation:

- Generate a spectrogram of the audio signal
- Identify peaks in the spectrogram
- The result looks as follows:

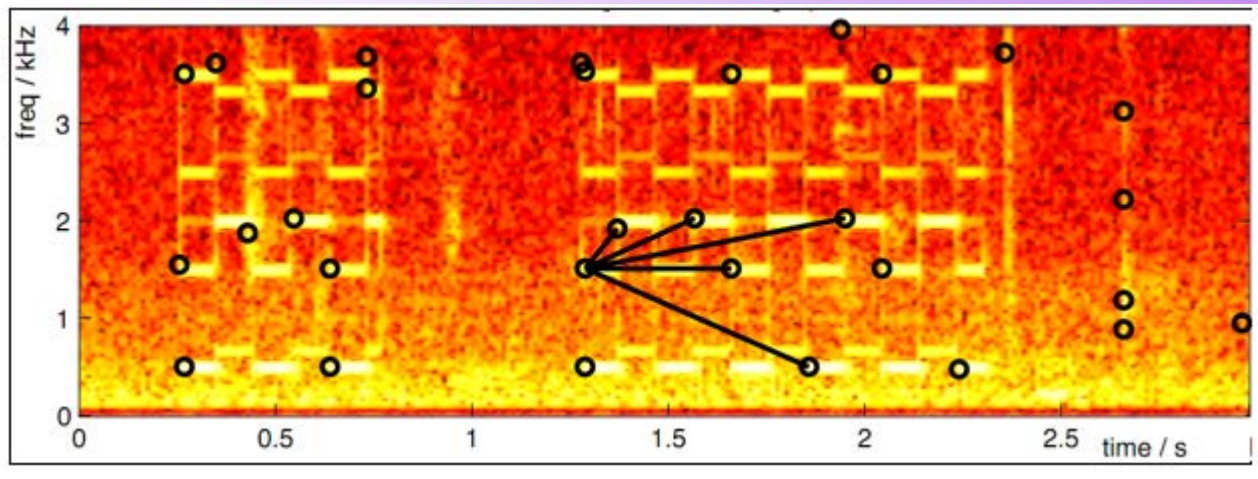

AUDIO ADVERTISEMENT DETECTION

Algorithm

- The algorithm is based on Shazam's algorithm
- The algorithm uses energy peaks in a frame to form spectral pair landmarks
- Robustness against noise is obtained by concentrating on spectral peaks
- Local maxima in a define section are grouped into pairs and hash-values are computed for the pairs

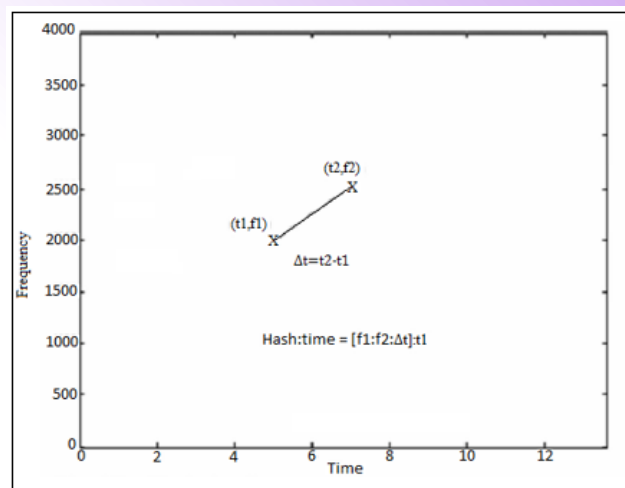

- These hash values are stored in a database

AUDIO ADVERTISEMENT DETECTION RESULTS

- First results indicated problems with detection time
- Computer engineering optimization techniques solved this
- The algorithm is quite accurate (>97%)

VIDEO ADVERTISEMENT DETECTION

- Most obvious approach: split video signal in audio and image signals
- Problem: some video advertisements are with out sound
- New approach: use the SIFT and SURF operators

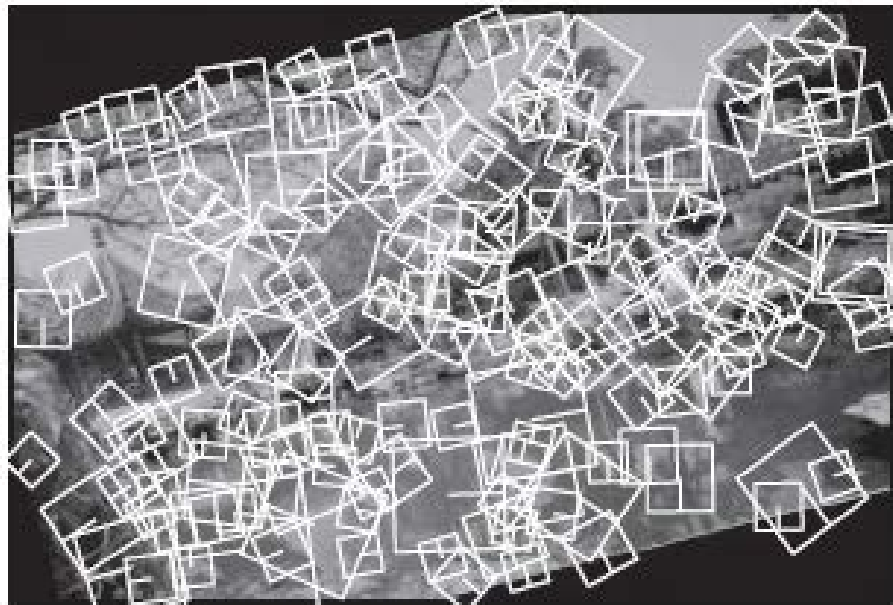

VIDEO ADVERTISEMENT DETECTION

Hashes

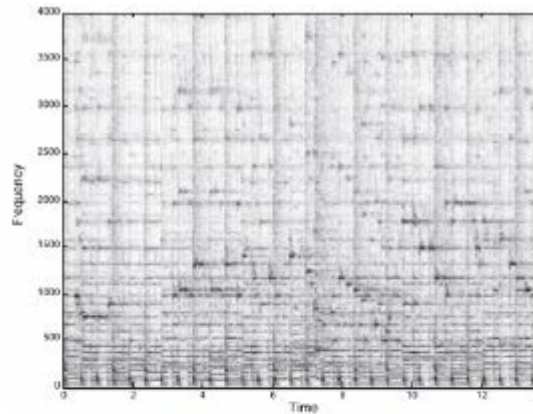

(a) Spectrogram

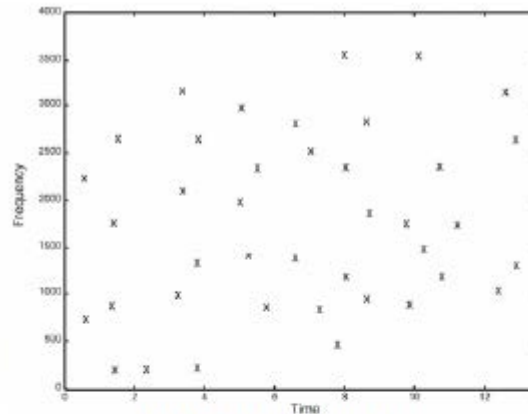

(b) Constellation Map

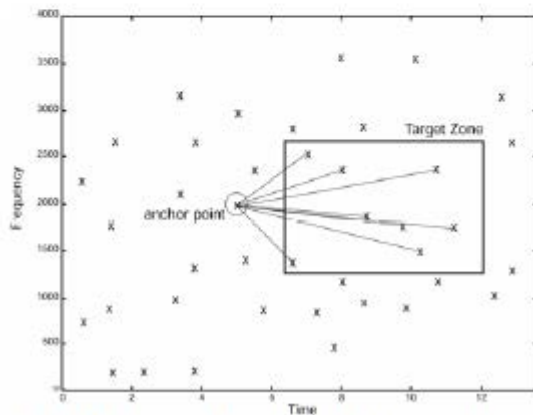

(c) Combinatorial Hash Generation

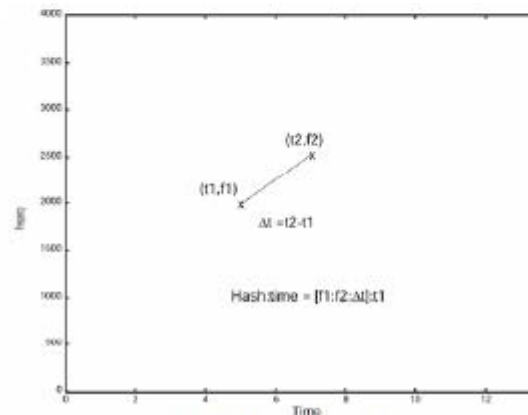

(d) Hash Details

VIDEO ADVERTISEMENT DETECTION

Hash generation

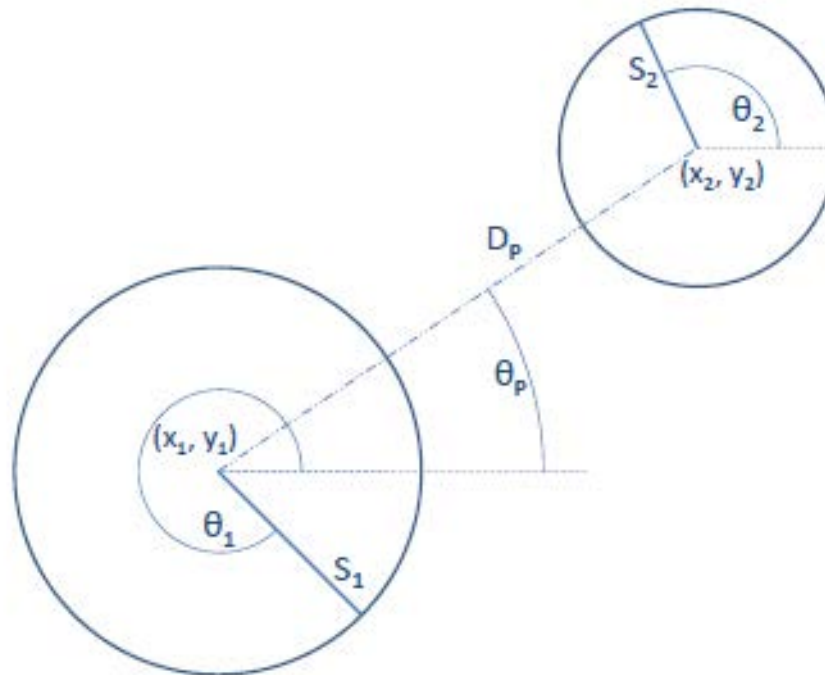

VIDEO ADVERTISEMENT DETECTION

Implementation

- It takes too long to calculate SIFT parameters for every frame
- New approach: use only key frames for advertisement detection
 - Key frames are frames in a signal where the information changes a certain amount between consecutive frames
 - This can be done using shot boundary detection
- Results: time to detect advertisement in an hour long video signal is 5 minutes
- Accuracy: >95%

COMPUTER ENGINEERING IN A CHANGING WORLD

Examples:

- Nokia
 - From milling to toilet paper to tires to cellphone company



COMPUTER ENGINEERING IN A CHANGING WORLD

Examples:

- Pittsburgh
 - Known for the Pittsburgh steelers



COMPUTER ENGINEERING IN A CHANGING WORLD

Examples:

- Pittsburgh
 - From steel factories to robotics



COMPUTER ENGINEERING IN A CHANGING WORLD

Observations:

- Both these businesses reinvented themselves to survive in a changing world
- The relevance of computer engineering in these reinventions is obvious

What happens when businesses don't adapt in a changing world?

- They do not survive
- Examples: Kodac, Minolta etc.

COMPUTER ENGINEERING IN A CHANGING WORLD

A South African perspective

Missed opportunities

- Personal computers
- Cell phones

Opportunities currently available:

- Self driving vehicles

Computer engineers can alleviate unemployment by making use of these opportunities

COMPUTER ENGINEERING IN A CHANGING WORLD

- Job opportunities for engineers:
 - Electrical engineers

[Home](#) / Job Search

Electrical Engineer Jobs

Results 1 - 10 of **108** Display per page Sort by:

- Electronic engineers

[Home](#) / Job Search

Electronic Engineer Jobs

Results 1 - 10 of **49** Display per page Sort by:

COMPUTER ENGINEERING IN A CHANGING WORLD

- Job opportunities for engineers:
 - Mechanical engineers

Home / Job Search

Mechanical Engineer Jobs

Results 1 - 10 of **104** Display per page Sort by:

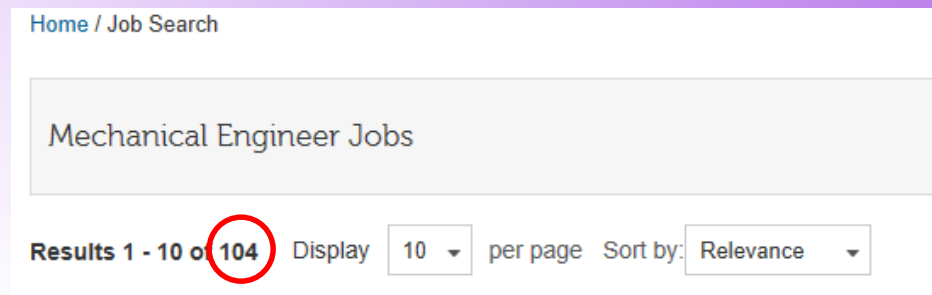

- Chemical engineers

Home / Job Search

Chemical Engineer Jobs

Results 1 - 10 of **25** Display per page Sort by:

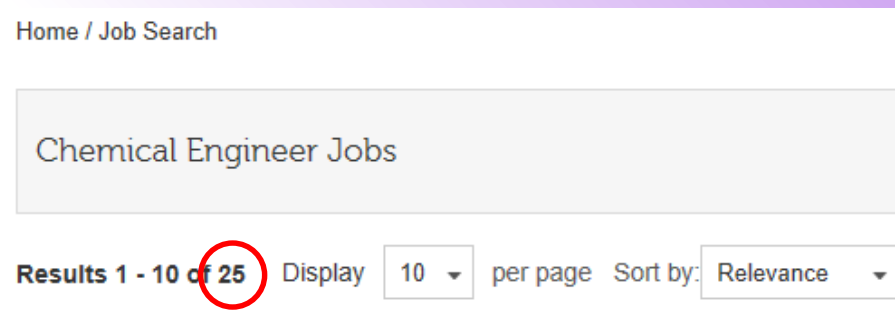

COMPUTER ENGINEERING IN A CHANGING WORLD

- Job opportunities for engineers:
 - Industrial engineers

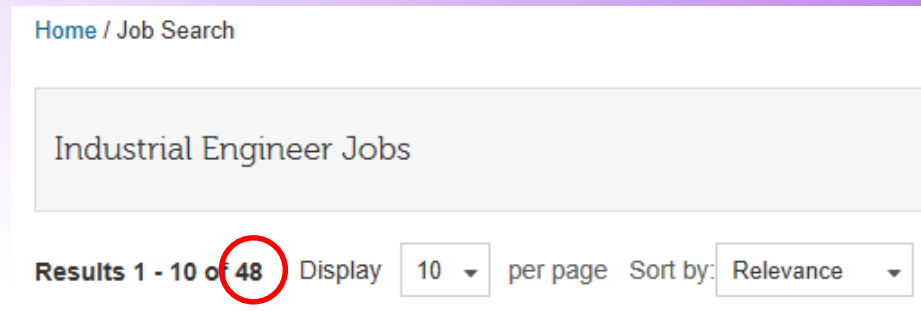

Home / Job Search

Industrial Engineer Jobs

Results 1 - 10 of 48 Display 10 per page Sort by: Relevance

The screenshot shows a job search interface. At the top, there is a breadcrumb trail "Home / Job Search". Below it is a search bar containing the text "Industrial Engineer Jobs". At the bottom of the search results area, there is a summary line: "Results 1 - 10 of 48". The number "48" is circled in red. To the right of "48" are controls for "Display 10 per page" and "Sort by: Relevance".

COMPUTER ENGINEERING IN A CHANGING WORLD

- Job opportunities for engineers:
 - IT engineers

Home / Job Search

It Engineer Jobs

Results 1 - 10 of **903** Display per page Sort by:

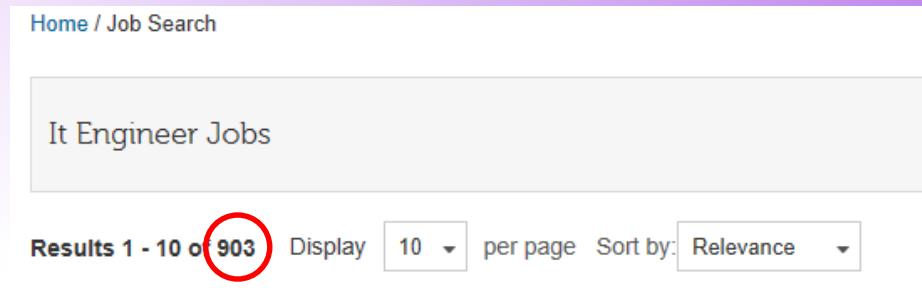
A screenshot of a job search interface. At the top, it says 'Home / Job Search'. Below that is a search bar containing the text 'It Engineer Jobs'. Underneath the search bar, it displays 'Results 1 - 10 of 903'. The number '903' is circled in red. To the right of the result count are controls for 'Display' (a dropdown menu showing '10'), 'per page', and 'Sort by:' (a dropdown menu showing 'Relevance').

- Programmers

Home / Job Search

Programmer Jobs

Results 1 - 10 of **949** Display per page Sort by:

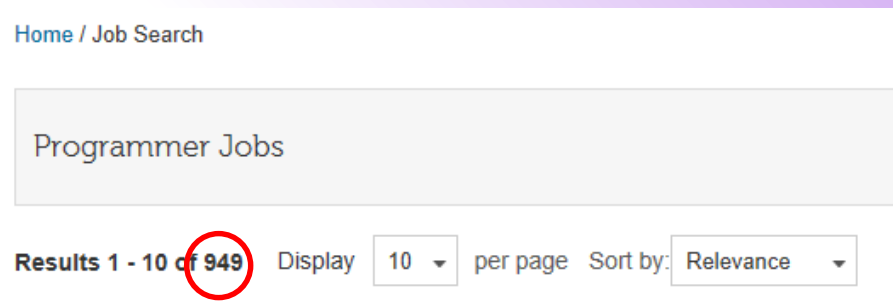
A screenshot of a job search interface. At the top, it says 'Home / Job Search'. Below that is a search bar containing the text 'Programmer Jobs'. Underneath the search bar, it displays 'Results 1 - 10 of 949'. The number '949' is circled in red. To the right of the result count are controls for 'Display' (a dropdown menu showing '10'), 'per page', and 'Sort by:' (a dropdown menu showing 'Relevance').

TO CONCLUDE:

- Computer engineering opportunities must be embraced and full advantage must be taken of these opportunities.
- If it is not done, these opportunities will be missed and we will only be left with regrets.

DIE ONSE VADER

