

**Cost and time effective DSM on mine compressed
air systems**

R. JOUBERT

Dissertation submitted in fulfilment of the requirements for the degree

MASTER OF ELECTRICAL ENGINEERING

at the Potchefstroom Campus of the North-West University

Supervisor: Dr Ruan Pelzer

November 2010

Pretoria

ABSTRACT

Title: Cost and time effective DSM on mine compressed air systems
Author: Mr R. Joubert
Supervisor: Dr R. Pelzer

Implementing demand side management (DSM) is expensive and often time consuming. Eskom grants subsidies for DSM projects based on the proposed savings. The subsidy granted is not always adequate to fund all the required control equipment to achieve the desired saving. This study focuses on alternative cost- and time-effective methods to implement DSM on gold mines, specifically on the compressed-air systems where the infrastructure is inadequate, worn out or outdated.

The compressors generating compressed air for mining are one of the largest electricity consumer at gold mines. By optimising the energy consumption of these compressed-air systems, the largest potential demand reduction can be achieved. This will lighten the demand load on the already overloaded national power grid.

Compressed air at gold mines is mainly used for production purposes, thus the majority of savings on these systems need to be achieved during non-production hours. Fixing air leaks, optimising compressor control, meticulous planning of implementation locations and controlling air usage are all methods that were investigated to achieve alternative cost- and time-effective methods to implement DSM on mine compressed-air systems.

The methods were implemented by an Energy Services Company (ESCO) at four different mines. The results achieved from these case studies are documented and discussed in this study.

Keywords: Cost efficient, Time efficient, DSM strategies, REMS CM

OPSOMMING

Titel: Koste en tyd effektiewe DSM op myn druklug stelsels
Outeur: Mnr R. Joubert
Studieleier: Dr R. Pelzer

Die implementering van “demand side management” (DSM) is dikwels duur en tydrowend. Die voorgestelde besparing bepaal die subsidies wat deur Eskom voorsien word vir DSM projekte. Die toegekende subsidies is soms onvoldoende om die nodige beheer toerusting te kan bekostig om sodoende die gewenste besparing te bereik. Hierdie studie fokus hoofsaaklik op alternatiewe koste- en tyd effektiewe metodes om DSM op goudmyne te implementeer, spesifiek op die druklug stelsels waar die infrastruktuur onvoldoende, verweer en verval is.

Die kompressors wat druklug genereer is die grootste verbruikers van elektrisiteit op goudmyne. Deur die energieverbruik van hierdie druklugstelsels te optimeer, kan die grootse potensiële aanvraag vermindering verkry word. Dit sal die las verlig op die alreeds oorlaaide nasionale elektrisiteitsnetwerk.

Druklug word hoofsaaklik gebruik vir produksie doeleindes op goudmyne. Dus moet die meerderheid van die besparings op hierdie stelsels gedurende die “nie-produksie ure” verkry word. Verskeie metodes is ondersoek om die mees koste effektiewe metodes te vind vir die implementering van DSM op myn druklug stelsels. Van hierdie metodes is onder meer die herstel van lekkasies; die optimalisering van kompressor beheer; die noukeurige beplanning van implementering en die beheer van lugverbruik.

Die alternatiewe metodes is geïmplementeer deur ‘n “Energy Services Company” (ESCO) op vier verskillende myne. Die resultate verkry vanuit die gevallestudies is ook gedokumenteer en bespreek in hierdie studie.

Sleutelwoorde: Koste effektief, Tyd effektief, DSM strategië, REMS CM

ACKNOWLEDGEMENTS

I want to thank my Lord and Saviour for the talents he has bestowed upon me. Without His grace and love I would not have succeeded in the challenges of life until now.

I also want to thank my parents for their love and support and giving me the opportunity to get a tertiary education. Through the good times and the tough times when everything did not go according to plan, they always stood by me.

A special word of thank you to my fiancée, Melanie, for her patience and understanding during the research and write-up of my master's dissertation. Your support and encouragement is what kept me motivated when working during the late hours of the night.

Lastly, I want to extend a word of thanks to my study leader, Dr. Ruan Pelzer for his support and guidance, as well as Mr. Dougie Veldman and Prof. Leon Liebenberg for their help and insight during this study. I also want to thank Prof. Eddie Mathews and Dr. Marius Kleingeld for the opportunity they gave me to complete a postgraduate degree.

TABLE OF CONTENTS

| | |
|---|-------------|
| ABSTRACT | i |
| OPSOMMING | ii |
| ACKNOWLEDGEMENTS | iii |
| TABLE OF CONTENTS | iv |
| LIST OF TABLES | vii |
| ABBREVIATIONS | viii |
| CHAPTER 1: INTRODUCTION | 2 |
| 1.1 INTRODUCTION | 2 |
| 1.2 THE INCREASE IN ELECTRICITY DEMAND | 2 |
| 1.3 MAJOR CONSUMERS OF ELECTRICITY..... | 6 |
| 1.4 ELECTRICITY SAVING INITIATIVES | 6 |
| 1.5 COST AND TIME IMPLICATIONS..... | 8 |
| 1.6 RESEARCH OBJECTIVES..... | 11 |
| 1.7 OVERVIEW OF CHAPTERS | 12 |
| 1.8 REFERENCES | 13 |
| 2 CHAPTER 2: BACKGROUND STUDY | 16 |
| 2.1 INTRODUCTION | 16 |
| 2.2 COMPRESSORS IN THE MINING INDUSTRY | 17 |
| 2.3 DIFFERENT METHODS AND STRATEGIES USED IN EXISTING COMPRESSED-AIR SYSTEM DSM | 22 |
| 2.4 COST OF IMPLEMENTING A TYPICAL DSM PROJECT ON COMPRESSED-AIR SYSTEMS..... | 25 |
| 2.5 CONCLUSION | 29 |
| 2.6 REFERENCES | 30 |
| 3 CHAPTER 3: COST- AND TIME-EFFICIENT CONTROL STRATEGIES AND PRINCIPLES | 34 |
| 3.1 INTRODUCTION | 34 |
| 3.2 IDENTIFYING DSM PROJECT POTENTIAL | 34 |
| 3.3 COMPRESSOR CONTROL..... | 39 |
| 3.4 ENERGY SAVING RESULTING FROM VALVE CONTROL..... | 42 |

| | | |
|----------|--|------------|
| 3.5 | EFFECTS OF LINE FRICTION | 43 |
| 3.6 | ALTERNATIVE STRATEGIES | 53 |
| 3.7 | CONCLUSION | 63 |
| 3.8 | REFERENCES | 63 |
| 4 | CHAPTER 4: VERIFICATION OF THE COST- AND TIME-EFFICIENT CONTROL STRATEGIES..... | 68 |
| 4.1 | INTRODUCTION | 68 |
| 4.2 | MINE A: SURFACE INFRASTRUCTURE WITH MULTIPLE COMPRESSOR HOUSES | 68 |
| 4.3 | MINE B: SURFACE INFRASTRUCTURE WITH MULTIPLE COMPRESSOR HOUSES | 76 |
| 4.4 | MINE C: SURFACE AND UNDERGROUND INFRASTRUCTURE WITH A SINGLE COMPRESSOR HOUSE .. | 83 |
| 4.5 | MINE D: SURFACE AND UNDERGROUND INFRASTRUCTURE WITH MULTIPLE COMPRESSOR HOUSES | 89 |
| 4.6 | CONCLUSION | 95 |
| 4.7 | REFERENCES | 96 |
| 5 | CHAPTER 5: RECOMMENDATIONS AND CONCLUSION | 98 |
| 5.1 | RECOMMENDATIONS FOR FURTHER WORK..... | 98 |
| 5.2 | COMPARISONS TO OTHER PROJECTS | 100 |
| 5.3 | CONCLUSION | 104 |
| | APPENDIX A: | 106 |

LIST OF FIGURES

| | |
|--|----|
| Figure 1: Eskom's electricity generation capacity in 2002 [1.4] | 3 |
| Figure 2: Cost of power plant technology [1.8]..... | 5 |
| Figure 3: Eskom TOU periods [1.13]..... | 9 |
| Figure 4: Time, cost and quality triangle | 11 |
| Figure 5: Costs associated with compressors..... | 16 |
| Figure 6: Types of compressors [2.3]..... | 17 |
| Figure 7: Stand-alone system | 18 |
| Figure 8: Ring-feed system..... | 19 |
| Figure 9: Flow meter installation [2.13] | 28 |
| Figure 10: Load shifting representation..... | 38 |
| Figure 11: Peak clipping representation..... | 38 |
| Figure 12: Energy efficiency representation..... | 38 |
| Figure 13: A typical compressor map illustrating the surge line [3.6]..... | 41 |
| Figure 14: Laminar flow [3.7] | 45 |
| Figure 15: Turbulent flow [3.7] | 45 |
| Figure 16: Relative roughness of a pipe [3.7]..... | 49 |
| Figure 17: Moody diagram | 50 |
| Figure 18: Globe valve [3.10]..... | 54 |
| Figure 19: Butterfly valve [3.12] | 54 |
| Figure 20: High performance butterfly valve [3.13] | 54 |
| Figure 21: a) Globe valve trim installed; b) Stack trim; c) Whisper trim | 56 |
| Figure 22: Mine A air reticulation layout (not to scale) | 69 |
| Figure 23: Pressure drop resulting from line losses at Mine A | 74 |
| Figure 24: Mine A load profile vs baseline | 75 |
| Figure 25: Estimated payback period for Mine A | 76 |
| Figure 26: Air reticulation layout of Mine B (not to scale) | 77 |
| Figure 27: Mine B load profile vs baseline | 81 |
| Figure 28: Estimated payback period for Mine B | 82 |
| Figure 29: The air reticulation layout of Mine C (not to scale) | 83 |
| Figure 30: Mine C load profile vs baseline | 87 |
| Figure 31: Estimated payback period for Mine C | 88 |
| Figure 32: The air reticulation layout of Mine D (not to scale) | 89 |
| Figure 33: Photo of a hydraulic power pack..... | 91 |
| Figure 34: Photo of a pneumatic piston on a loader..... | 92 |
| Figure 35: Mine D load profile vs baseline | 94 |
| Figure 36: Estimate payback period for mine D | 95 |

LIST OF TABLES

| | |
|--|-----|
| Table 1: Eskom generation sources by 2008 [1.1] | 4 |
| Table 2: South Africa's largest electricity consumers [1.12] | 6 |
| Table 3: Eskom Megaflex tariffs [1.13]..... | 8 |
| Table 4: Consumers of compressed air [2.6], [2.7] | 20 |
| Table 5: Site components | 25 |
| Table 6: Infrastructure costs | 28 |
| Table 7: DSM projects | 37 |
| Table 8: Flow types..... | 44 |
| Table 9: Pipe roughness design values [3.8] | 49 |
| Table 10: Valve types | 54 |
| Table 11: Cost of air leaks | 59 |
| Table 12: Implemented instrumentation at Mine A..... | 70 |
| Table 13: Implemented instrumentation at Mine B..... | 78 |
| Table 14: Implemented instrumentation at Mine C..... | 84 |
| Table 15: Implemented instrumentation at Mine D..... | 90 |
| Table 16: Benchmark projects | 101 |
| Table 17: Cost per MWh..... | 101 |
| Table 18: Percentage energy saving achieved | 102 |
| Table 19: Average time of implementation..... | 102 |
| Table 20: Post-performance assessment savings | 103 |
| Table 21: Treatment of public holidays during Megaflex periods | 106 |

ABBREVIATIONS

| Abbreviation | Description |
|--------------|---|
| CFM | Cubic Feet per Minute |
| CM | Compressor Manager |
| CMS | Cubic Feet per Second |
| DSM | Demand Side Management |
| ESCo | Energy Services Company |
| ID | Inside Diameter |
| I/O | Input/Output |
| GW | Gigawatt |
| kPa | Kilopascal |
| kV | Kilovolt |
| kW | Kilowatt |
| kWh | Kilowatt-hour |
| MVA | Megavolt-ampere |
| MW | Megawatt |
| MWh | Megawatt-hour |
| mA | Milli-ampere |
| NERSA | National Energy Regulator of South Africa |
| PLC | Programmable Logic Controller |
| SCADA | Supervisory Control and Data Acquisition |
| PCP | Power Conservation Programme |
| REMS CM | Real-time Energy Management System Compressor Manager |
| TOU | Time-of-use |
| ZAR | South-African Rand |



INTRODUCTION

Chapter 1: The demand for electricity in South Africa has reached a level where it almost surpasses the supply. Alternative energy efficient methods are required to save electricity. The focus of this study will be to find cost- and time-effective methods to reduce the electricity consumption of compressors installed at mines.

CHAPTER 1: INTRODUCTION

1.1 Introduction

Eskom generates about 95% of South Africa's electricity of which 85% is generated using coal plants [1.1]. The total generation capacity of coal-fired plants, newly built plants, returned-to-service plants and nuclear plants in South Africa is 50.2 GW [1.1].

From 1994–2007 there was a 50% increase in the electricity demand in South Africa [1.2]. This drastic increase in electricity demand has caused an imbalance between the electricity supply and the demand in the country.

Eskom was forced to introduce aggressive initiatives to reduce the consumption of the current electricity consumers and increase the available generation capacity of the national power grid. Eskom's Demand Side Management (DSM) [1.5] programme is one such initiative. This initiative funds approved projects submitted by independent Energy Services Companies (ESCO's) [1.6] to reduce the electricity consumption of major electricity consumers.

Industrial air compressors consume approximately 9% of the total electricity generated in South Africa. Most of these air compressors are installed on mines [1.7]. Various strategies can be implemented during energy saving projects to possibly reduce the electricity demand of these compressors. Some of these strategies are inexpensive, with a small but immediate effect, while others are more complex and therefore more expensive to implement. In general, the more expensive interventions usually have a greater impact on the electricity savings.

1.2 The increase in electricity demand

Since 1997 the growth in electricity demand has not been matched by the supply. This has resulted in the demand for electricity in South Africa exceeding the supply, resulting in everyday load shedding in 2008. Continuous load shedding

also contributed to the 1.57% decline in the economic growth during the first quarter of 2008 [1.2].

To resolve this problem Eskom has returned to service three previously decommissioned power plants. These plants will provide an additional 3.8 GW to the national power grid until new plants can be introduced into service. Eskom has obtained a \$3.75-billion loan from The World Bank [1.3] and additional funding from government to build new power plants that will generate an additional 22 GW by 2017 [1.1].

Figure 1 depicts Eskom's 37 GW electricity generation capacity in 2002 and the life expectancy of the power stations operating at that time. This figure clearly shows that if no new power stations are going to be built, electricity generation capacity will cease in 2052.

Since 2002 the building of new power stations have commenced of which some have already been completed. This boosted the generation capacity to the 50.2 GW presently available. Table 1 lists a breakdown of the generation sources during 2008.

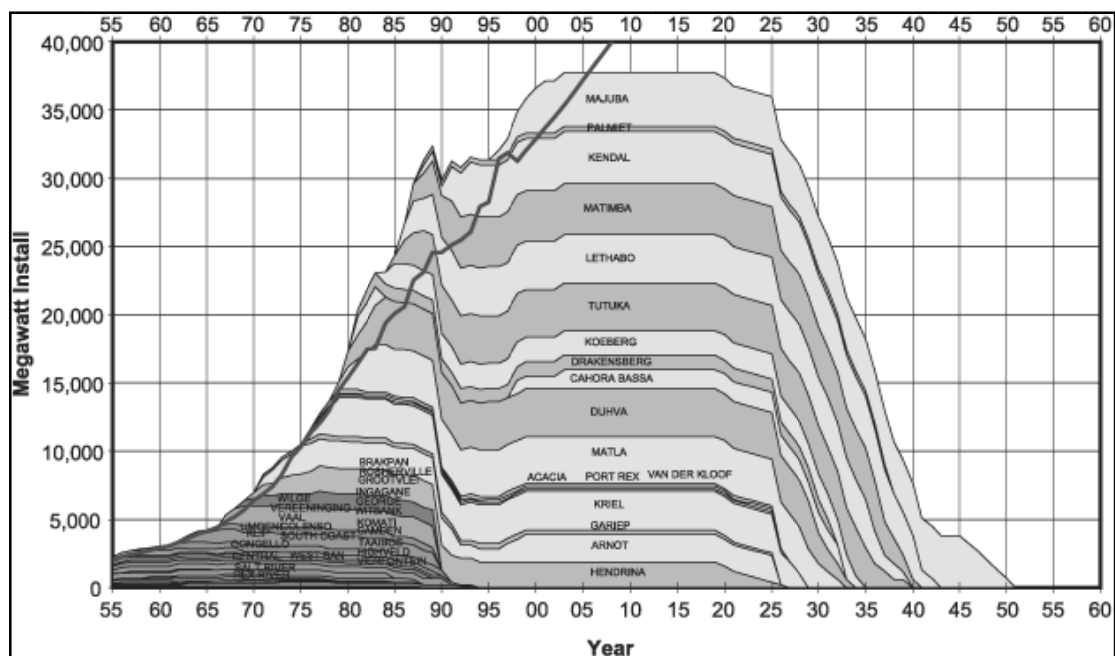

Figure 1: Eskom's electricity generation capacity in 2002 [1.4]

Table 1: Eskom generation sources by 2008 [1.1]

| Baseload | Capacity (MW) | Other | Capacity (MW) |
|-------------------------------------|----------------------|-------------------------------|----------------------|
| Coal-fired | | Hydro | |
| Arnot | 2,100 | Gariep | 360 |
| Duvha | 3,600 | Vanderkloof | 240 |
| Hendrina | 2,000 | Hydro distribution | |
| Kendal | 4,116 | First Falls | 6.4 |
| Kriel | 3,000 | Second Falls | 11 |
| Lethabo | 3,708 | Colley Wobbles | 42 |
| Majuba | 4,110 | Ncora | 24 |
| Matimba | 3,990 | Pumped storage | |
| Matla | 3,600 | Drakensberg | 1,000 |
| Tutuka | 3,654 | Palmiet | 400 |
| New Build (coal) | | Ingula (new build) | 1,332 |
| Medupi | 4,788 | Open cycle gas turbine | |
| Return-to-service (coal) | | Acacia | 171 |
| Camden | 1,600 | Port Rex | 171 |
| Grootvlei | 1,200 | Ankerlig | 592 |
| Komati | 1,000 | Gourikwa | 444 |
| Nuclear | | Gas I (new build) | 1,036 |
| Koeberg | 1,930 | Wind | |
| | | Klipheuwel | 3.2 |
| Total baseload | 44,396 | Total other | 5,833 |
| Coal share of total capacity | 42,466 | Total overall capacity | 50,229 |

The type of power stations planned for construction will be determined by their cost per megawatt (MW) and expected lifespan. Figure 2 illustrates the estimated construction cost of various types of power stations in US dollars by 2015. Although nuclear power plants are the most expensive, they are more environmentally friendly and have a life expectancy in excess of 40 years [1.9].

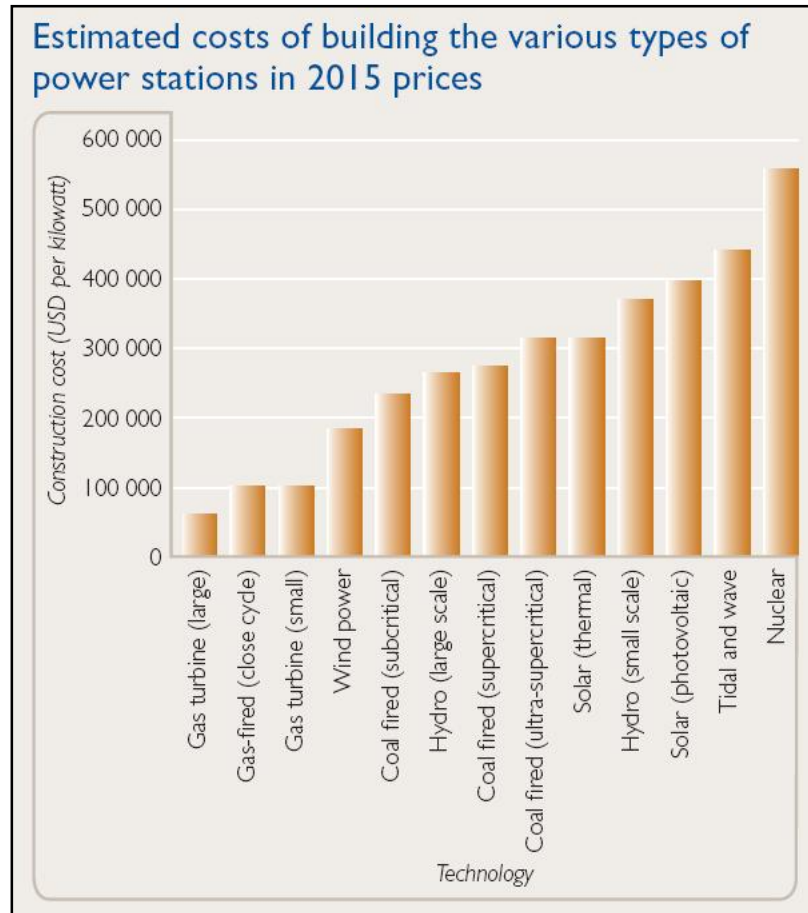

Figure 2: Cost of power plant technology [1.8]

The cheapest power station does not necessarily generate the cheapest electricity. Maintenance costs as well as the cost to generate electricity have to be taken into account when deciding which type of power station to build. During 2008, the average cost per megawatt-hour (MWh) in the USA was \$65/MWh for electricity generated by a coal-fired power plant [1.10]. This was less than the cheaper-to-build gas-fired power stations that generated electricity at an average cost of \$72.5/MWh [1.11].

Although new power plants (such as the Medupi and Kusile coal-fired plants) are currently under construction, electricity must still not be wasted. Eskom has received approval from the National Energy Regulator of South Africa (NERSA) to increase electricity tariffs by 35% each year, over the next three years, to gain the

funds required to improve and maintain the national power grid [1.2]. This will result in a significant increase in electricity costs for all electricity consumers.

Energy saving initiatives must become a priority to assist Eskom in regaining the balance between electricity demand and supply, and to help the electricity consumers save money on electricity bills.

1.3 Major consumers of electricity

Electricity consumption of some of South Africa's largest electricity consumers are listed in Table 2.

Table 2: South Africa's largest electricity consumers [1.12]

| Consumer | Electricity use [%] |
|--|---------------------|
| Iron and steel industry | 22.91 |
| Precious and non-ferrous metals industry | 16.55 |
| Gold mines | 15.36 |
| Wood and wood production industry | 8.18 |
| Platinum mines | 6.13 |

Compressor systems installed on mines are, as a whole, one of the single largest consumers of electricity in the industrial sector. These compressor systems utilise 9% of the total electricity consumption in South Africa [1.7].

1.4 Electricity saving initiatives

The national electricity supplier, Eskom, is committed to saving electricity through various strategies. With the focus on major industrial consumers, the Power Conservation Programme (PCP) and DSM projects are the most significant initiatives.

The PCP requires that the South African mining industry, along with other industrial and commercial industries, reduce their electricity demand by 10% [1.8]. Failure to do this will result in severe penalties to the consumer [1.8]. 250 of South Africa's largest energy consumers have voluntarily joined the PCP. The PCP is in the final procurement phase where after it will be implemented at all major energy consumers [1.8].

When the PCP is implemented, industries will be required to reduce their electricity demand by at least 10% compared to their electricity demand during the period 1 October 2006 to 30 September 2007. Failure to do so will result in additional charges payable to Eskom [1.8].

Eskom subsidises DSM projects based on a proposed electricity demand reduction and the time of day when the reduction will be achieved. There are various types of DSM initiatives that focus on specific categories of energy consumers.

One of these initiatives is to control and reduce the supply and demand of compressed air systems at mines. This is needed because the generation of compressed air consumes large amounts of energy [1.7].

Examples of optimising the supply side are:

- Lower the system pressure;
- optimise compressor delivery control; and/or
- implement multiple compressor control.

Examples of demand side control are:

- Air flow and air pressure regulation;
- manage air leaks; and
- re-evaluate line sizes to reduce line friction.

There are various costs involved in optimising and improving an air network and its subcomponents. These costs will be discussed in detail in Chapter 2.

1.5 Cost and time implications

Urban electricity consumers, who are able to shift load and has a notified maximum demand higher than 1 MVA, will be billed according to Eskom's Megaflex tariffs [1.13]. Table 3 lists the tariffs for a 66 kV consumer that is located 300–600 km from the capital point in Johannesburg.

In general, Megaflex tariffs are based on seasonal as well as time-of-use (TOU), periods. The seasonal periods are divided into high and low demand seasons as demonstrated in Table 3.

Table 3: Eskom Megaflex tariffs 2010/2011 [1.13]

| Transition zone and voltage | High demand season (Jun–Aug) [c/kWh] | | | Low demand season (Sep–May) [c/kWh] | | |
|---|---|----------|----------|--|----------|----------|
| | Peak | Standard | Off-peak | Peak | Standard | Off-peak |
| > 600 km and ≤ 900 km and ≥ 66 kV and ≤ 132 kV | 167.39 | 43.53 | 23.28 | 46.74 | 28.64 | 20.04 |

The TOU periods are subdivided into weekdays, Saturdays and Sundays. Peak periods are only allocated to weekdays between 07h00–10h00 and 18h00–20h00, as depicted in Figure 3. For the purpose of Megaflex tariffs, public holidays are considered as either Saturdays or Sundays, depending on the specific day [1.13]. Table 21 in the Appendix provides a list of South African public holidays and the relevant demand periods allocated to them.

The focus of energy saving initiatives is to save electricity in both the morning and evening peak periods. This helps to lower the peak demand that enables Eskom to match the electricity supply to the demand within the present generation capacity of its power plants. As an incentive, lower tariffs are charged during off-peak and standard times. Consumers are therefore encouraged to reduce electricity during the peak periods.

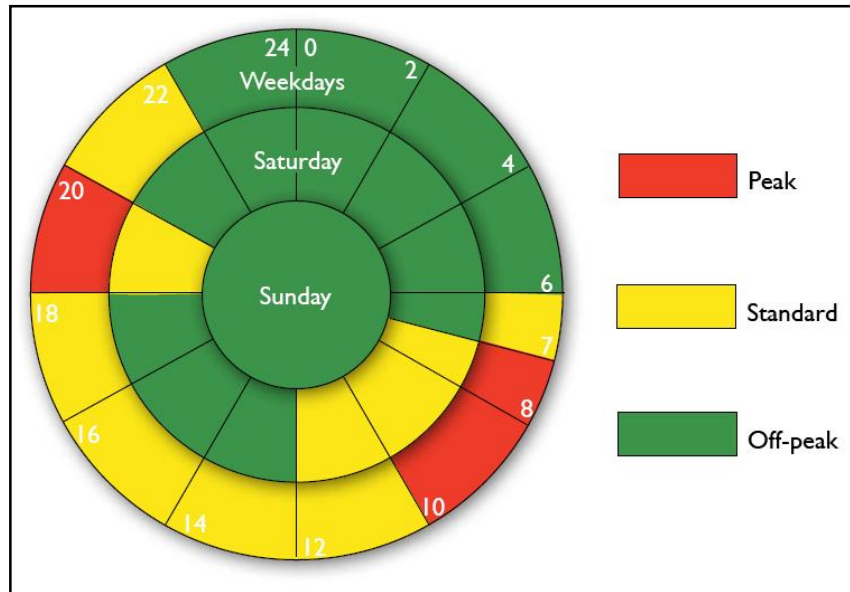

Figure 3: Eskom TOU periods [1.13]

There are three types of DSM projects that can be implemented to reduce electricity demand during peak periods at sites where Megaflex tariffs apply. The time of use, the electricity savings potential, and the available budget will determine the type of DSM project that will be implemented. A brief description of these initiatives is given below. These projects and their implementations will be discussed in detail in Chapter 3.

- Load shifting:** Also referred to as energy neutral projects. The 24-hour energy consumption of these particular projects remain constant but the daily time uses are changed. Thus, money is saved on electricity costs by using less electricity during the expensive peak periods.
- Load shedding:** To achieve savings, the energy consumption during the Eskom peak periods must be reduced. This implies that the reduction in electricity demand, resulting from reduced production services during peak periods, is directly reflected on the monthly electricity bill.

- **Energy efficiency:** These projects aim to save energy continuously on a 24-hour basis. To achieve this type of saving extensive investigations need to be undertaken that focus on all the potential opportunities to reduce wastage and optimise usage throughout the day.

The cost of implementing a DSM project differs from project to project. A preliminary investigation regarding the cost of DSM projects, currently installed on compressed-air systems at mines, found that the average cost per project can vary between R3 million and R7 million with an average installation period ranging between 8–12 months.

In general, the more integrated the infrastructure of the proposed projects, the longer it will take to implement and the more expensive it will be. Although fewer equipment is cheaper and can be implemented in less time it is likely that the optimal savings would not be achieved. Prolonging the implementation period will result in excessive electricity charges continuously paid to Eskom due to the energy wasted by the existing inefficient air system.

DSM projects use a cost, time and quality evaluation model to decide on which DSM projects are viable. The cost, time and quality evaluation of a project can be explained by the cost/time/quality triangle as shown in Figure 4. When one corner of the triangle is changed, the result will have a positive impact on one of the opposing corners while having a negative impact on the other.

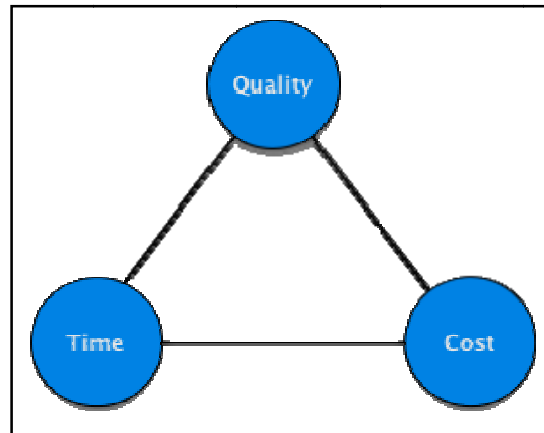

Figure 4: Time, cost and quality triangle

“Time and costs are at best, only guesses, calculated at a time when least is known about the project. Quality is a phenomenon, it is an emergent property of peoples deferent attitudes and beliefs, which often change over the development life-cycle of a project [1.14].”

A balance between the cost of the project; the time taken to implement; and the quality of the final product needs to be found to satisfy all involved parties. This concept is applicable to DSM projects implemented on mine compressed-air systems.

The quality measurements for a DSM project would be the impact and sustainability of the project. On the demand side, the client would prefer the project to continuously achieve the proposed saving in order to reap the benefit of saving on electricity charges. Furthermore, Eskom would prefer a DSM project to be sustainable to ensure a permanent reduction in the electricity demand of the national power grid.

1.6 Research objectives

There are various types of energy management projects with various outcomes. One of the most influential aspects of these projects is the cost of implementation and the time it takes to implement.

The objective of this research study will be to find alternative methods to reduce the implementation time of DSM projects implemented on mine compressed-air systems. These methods also need to be more cost effective than the existing implementation methods. The alternative methods will aid mines that have limited budgets available for implementing DSM projects; and where the compressed-air system infrastructures are inadequate, outdated or have excessive maintenance costs.

The identified methods will be implemented on existing mine compressed-air networks where the requirement for air network optimisation has been identified. The outcome of each case study will be documented and discussed.

1.7 Overview of chapters

A brief overview of the chapters is given below.

Chapter 2: Background study

This chapter contains the background on compressors and compressed-air networks at mines. This information will be used to identify key aspects that need to be researched before alternative cost- and time-efficient methods can be formulated.

Chapter 3: Cost- and time-efficient control strategies and principles

This chapter documents the research done on aspects such as compressor control, valve selection, line friction, alternative instrumentation and air leaks. Using this information, proposed strategies can be formulated for implementation.

Chapter 4: Verification of cost- and time-efficient control strategies

Four completed case studies are discussed in this chapter. The discussion focuses on the implementation of the strategies discussed in Chapter 3 on the four case studies and the results achieved.

Chapter 5: Recommendations and conclusions

Recommendations for future work to the case studies are provided in this chapter, as well as a comparison to other projects of a similar nature. This chapter will also feature a general overview of the study and the conclusion.

1.8 References

- [1.1] U.S energy information administration. (2010, September 4). *South Africa energy data* [Online]. Available:
http://www.eia.doe.gov/emeu/cabs/South_Africa/Electricity.html

- [1.2] R. Inglesi & P. Anastossios, "Forecasting electricity demand in South Africa: A critique of Eskom's projections," *South African Journal of Science*, vol. 106, no. 1–2, pp. 50–53, 2010.

- [1.3] J. Roberts, Mail & Guardian online. (2010, April 9). *World Bank approves Eskom loan* [Online]. Available:
<http://www.mg.co.za/article/2010-04-09-world-bank-approves-eskom-loan>

- [1.4] B. Mehlomakulu, The International Development Research Centre. (2010 September 4). *Hydrogen and fuel-cell technology issues for South Africa: The emerging debate* [Online]. Available:
http://www.idrc.ca/en/ev-132192-201-1-DO_TOPIC.html

- [1.5] ESKOM DSM. Eskom, Megawatt Park, Maxwell Drive, Sunninghill, Sandton, South Africa.

- [1.6] SAAEs. (2010, September 4). *South African Association of Energy Services companies* [Online]. Available: <http://esco.org.za/esco/>

- [1.7] R. Saidur, N.A. Rahim & M. Hasanuzzaman. "A review on compressed-air energy use and energy savings," *Renewable and Sustainable Energy Reviews*, vol. 14, pp. 1135–1153, 2010.
- [1.8] Annual Report 2009. Eskom, Megawatt Park, Maxwell Drive, Sunninghill, Sandton, South Africa.
- [1.9] B. De Wachter, Leonardo ENERGY. (2010, September 5). *Life expectancy of nuclear power plants* [Online]. Available: <http://www.leonardo-energy.org/drupal/node/1530>
- [1.10] ETSAP. (2010, October 2). *Coal-fired power* [Online]. Available: <http://www.etsap.org/E-techDS/PDF/E01-coal-fired-power-GS-AD-gct.pdf>
- [1.11] ETSAP. (2010, October 2). *Gas-fired power* [Online]. Available: http://www.etsap.org/E-techDS/EB/EB_E02_Gas_fired%20power_gs-gct.pdf
- [1.12] A. Hughes, M.I. Howells, A. Trikam, A.R. Kenny & D. van Es, "A study of demand side management potential in South African industries," *Energize*, pp16–22, Sept. 2006.
- [1.13] Eskom Tariff Book. Eskom, Megawatt Park, Maxwell Drive, Sunninghill, Sandton, South Africa.
- [1.14] R. Atkinson, "Project management: Cost, time and quality, two best guesses and a phenomenon, its time to accept other success criteria," *International Journal of Project Management*, vol. 17, no. 6, pp. 337–342, 1999.

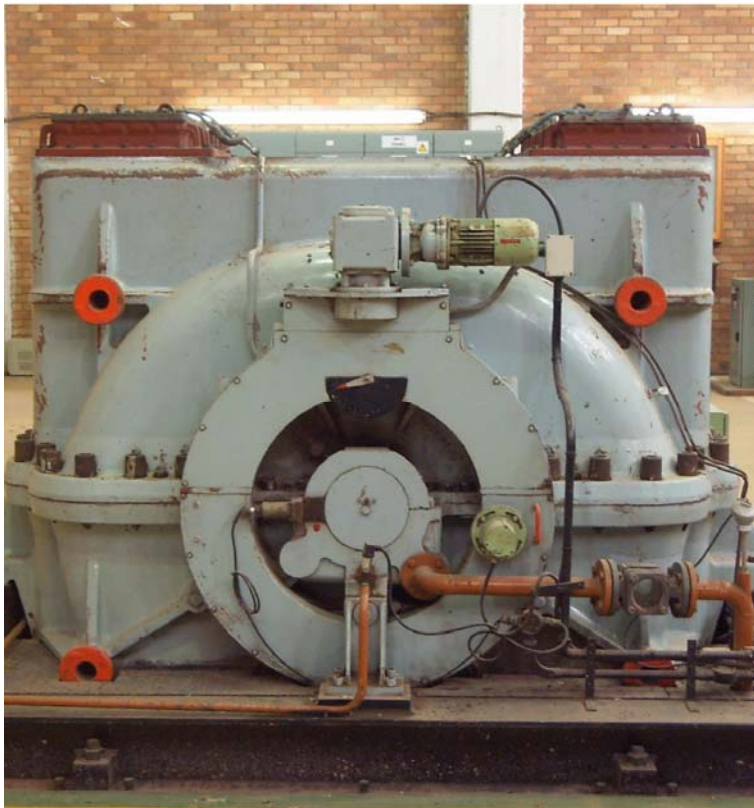

BACKGROUND STUDY

Chapter 2: An overview of compressed-air networks; subcomponents; and the cost of installing control infrastructure on these components. Suggestions for alternative cost- and time-efficient strategies are made based on the information gathered during the background study.

2 CHAPTER 2: BACKGROUND STUDY

2.1 Introduction

The focus of this study is to find alternative cost- and time-efficient methods to save energy on compressed-air systems at mines. To achieve this goal, it is necessary to understand the operation of compressed-air networks and the components that make up the network.

Compressors, as a group, are the largest single consumer of electrical energy at a mine. According to published data, compressors make up 9%–10% of the energy demand in the industrial sector [2.1], [2.2].

The energy cost of compressors contribute approximately 78% to the total compressor's cost over its lifetime. The remaining 22% is contributed to maintenance and initial installation costs [2.2]. Figure 5 depicts the percentages of the costs allocated to these areas.

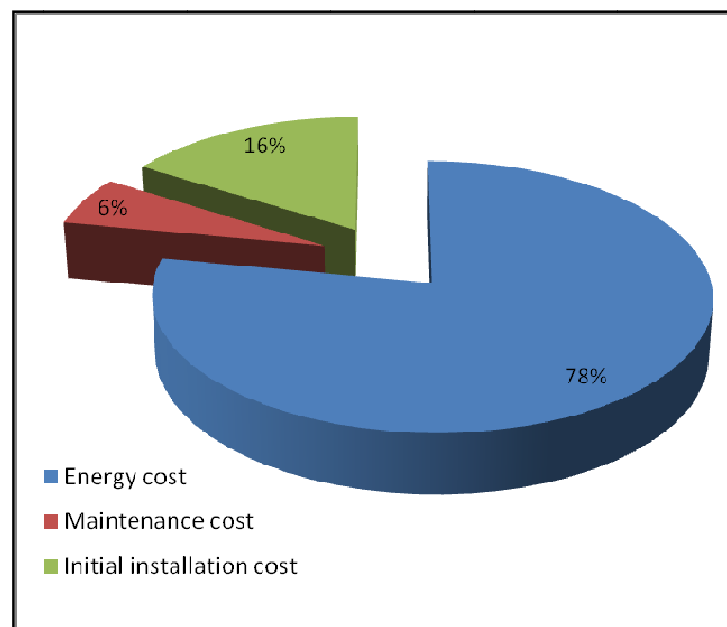

Figure 5: Costs associated with compressors

These figures indicate that energy savings strategies will be of great benefit to mining companies. One obvious method to save electricity is to reduce the demand for compressed air. There are various strategies to control and reduce the demand for compressed air on the demand side of the air network.

2.2 Compressors in the mining industry

2.2.1 Types of compressors

There are various types of compressors available, each with its own set of advantages and disadvantages. Figure 6 depicts a visual list of some types of compressors.

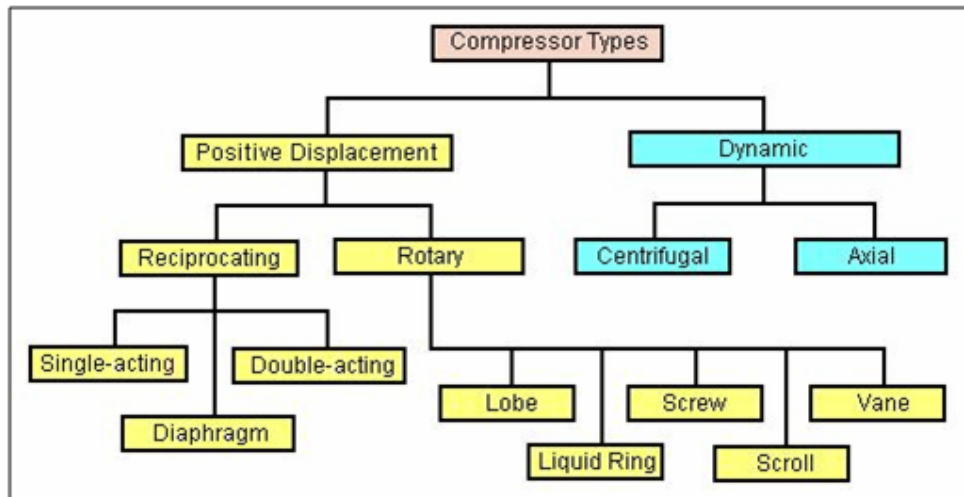

Figure 6: Types of compressors [2.3]

Centrifugal compressors are commonly used to provide compressed air at mines. Some advantages of the centrifugal compressor are [2.4]:

- There are fewer frictional parts when compared to positive displacement compressors;
- delivery pressure is controllable by means of the inlet guide vanes;
- relatively energy efficient; and
- they have a higher airflow than positive displacement compressors of the same capacity.

A common drawback to dynamic compressors is that they cannot achieve the high-pressure ratios that are characteristic of positive discharge compressors.

2.2.2 Compressed-air networks

A compressed-air network connects the compressors on the supply side of the network, to the compressed-air consumers on the demand side of the network. The network is constructed from steel pipes that allow the compressed air to flow from the supply to the demand side.

The type of compressed-air network is characterised by the layout of the specific site. There are two types of compressed-air networks:

- Stand-alone networks; and
- ring-feed networks.

A typical stand-alone system is where one source is connected to a one- or two-air consumer. In some cases there might be a gold plant that also requires compressed air. Refer to Figure 7 for a graphical representation of a stand-alone system.

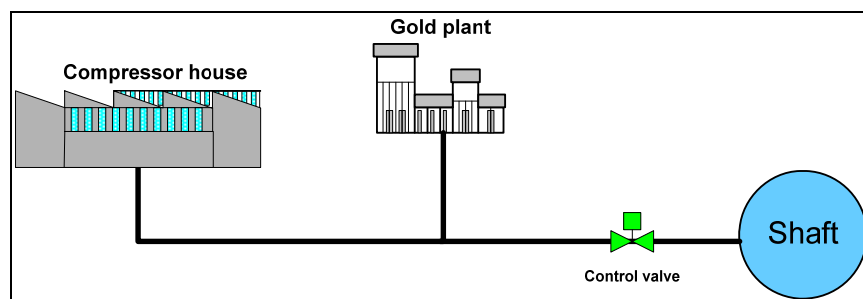

Figure 7: Stand-alone system

A ring-feed system consists of various sources and air consumers on the air network. This air network is also known as a compressed-air ring. Refer to Figure 8 for a graphical representation of a typical compressed-air ring.

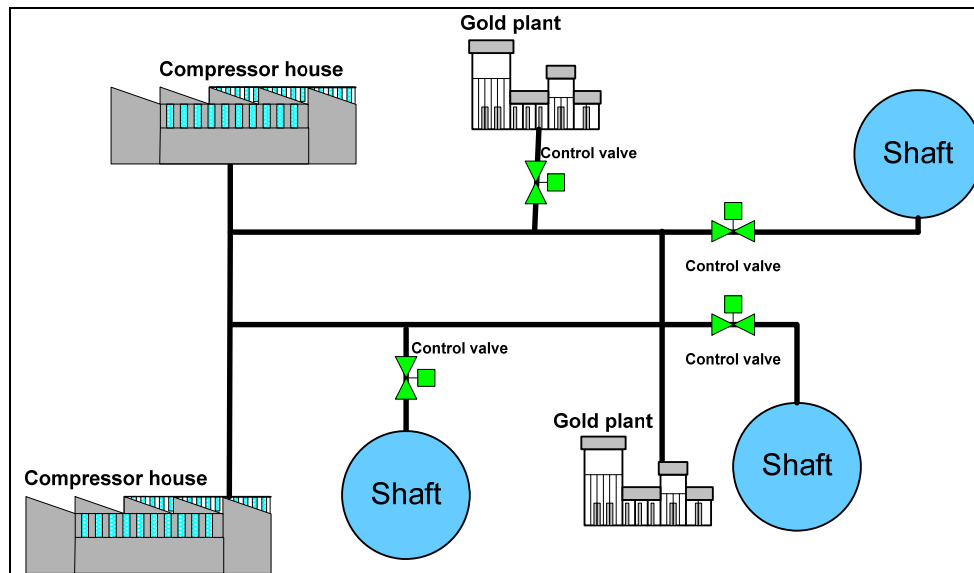

Figure 8: Ring-feed system

Because ring-feed networks are the most commonly used networks at mines, some advantages and disadvantages of these networks are listed below.

Advantages of a ring-feed system:

- Various control options can be considered;
- air supply can be decentralised; and
- the logistics surrounding ring maintenance is simplified. With various supply sources, the demand for compressed air can be met even if some sections of the air ring are isolated.

Disadvantages of a ring-feed system:

- Maintenance cost will be high due to the scale of the infrastructure. Larger pressure drops resulting from line losses when compared to a stand-alone system; and
- the system pressure at various points will differ due to various bleed off points feeding compressed air to the air consumers.

2.2.3 Applications using compressed air

Pneumatic equipment is used on the surface as well as underground. Because all the air consumers are connected to a common, main air line, the equipment with the highest pressure requirement will determine the maximum pressure set point of the air ring [2.5].

Distinguishing between air consumers, and their time of use, will later allow for control infrastructure and control schedules to be implemented on the air system. The largest percentage of compressed air is consumed underground. Table 4 lists some of the underground air consumers and their typical consumption.

Table 4: Consumers of compressed air [2.6], [2.7]

| Pneumatic equipment | Function in the mining environment | Required flow rate per unit (m ³ /s)* |
|---------------------------------------|--|--|
| Rock drills | Pneumatic drills are the main consumers of compressed air. They are used to drill 1.8 m deep holes on the rock face wherein the charges, used for blasting, are placed. | 0.42 |
| Mechanical ore loaders (LM250) | Mechanical ore loaders are used to load the mined ore into the loading boxes. For optimal operation, these loaders require constant airflow at a fixed pressure. | 0.28 |
| Diamond drills | Diamond drills are used for development on the mining levels. Development of the mining levels is not coupled with production shifts. Therefore, these drills can be used at times of day that are different to that of the production shifts. | 0.14 |

| Pneumatic equipment | Function in the mining environment | Required flow rate per unit (m ³ /s)* |
|-----------------------|--|--|
| Refuge bays | Refuge bays are secure chambers that provide a place of safety for underground personnel in case of an emergency. Compressed air is used to provide a positive atmospheric charge (relative to the outside pressure) to the refuge bay. By doing so, dangerous and potential toxic gases are kept out of the refuge bay. | 0.01 |
| Loading boxes | Loading boxes are used to load ore into the skips**. | 0.026 |
| 50mm blow pipe | Open-ended air lines are sometimes used for ventilation in poorly ventilated sections. It is not recommended to use compressed air for ventilation, but personnel working in hot, humid and uncomfortable sections will sometimes do it to get relief from these conditions. | 0.47 |

*All the calculations were done using a 700 kPa supply pressure.

**A skip can be hoisted and lowered up-and-down the shaft. It is used to extract ore from underground.

Gold plants are the main air consumers on the surface and these plants can consume between 0.08 m³/s and 0.7 m³/s at a constant air pressure throughout the day. The compressed air fed to these plants is mainly used for agitation and pneumatic instrumentation such as valve actuators. Smaller air consumers, such as workshops and training centres, only require compressed air during certain times of the day. The required pressure and volumetric flow rate to these air consumers will depend on what application compressed air is used for.

2.3 Different methods and strategies used in existing compressed-air system DSM

In most cases, an unmaintained compressed-air network has a 20%–50% energy savings potential [2.10]. There are various sections on the compressed-air network that can be improved to achieve this saving. Energy saving strategies can be subdivided into supply side- and demand side strategies, which will be discussed in the following sections.

2.3.1 Supply side control

Energy savings can be achieved by controlling the amount of compressed air delivered to the system and the pressure by which it is delivered. In most cases the compressor networks are overpressurised when operated manually, which will cause the system to maintain a typical constant set point of 600 kPa–700 kPa [2.9].

A specified amount of air is delivered to the air network at a specific pressure [2.8]. By lowering the set point for the compressor-discharge pressure, the electricity consumed by the compressor will also be reduced. A general accepted estimation of a compressor's electrical efficiency is that it will improve by 1% for every 14 kPa drop in pressure [2.1].

The discharge pressure, and the delivered mass flow of a compressor, can be lowered and controlled by throttling the guide vanes on the air intake of the compressor [2.8].

Guide vane control is one of the methods that has a direct effect on the energy consumption of a compressor. By reducing the mass-flow of air through the compressor, the strain on the motor driving the compressor is reduced, thereby consuming less energy when driving the compressor.

2.3.2 Load sharing

Compressors on the same network can vary in size and efficiency. The maximum energy savings can be achieved if the most efficient combinations of compressors

share the load that results from the demand for compressed air. Between two compressors of the same type, the larger one of the two will deliver more cubic feet per minute (cfm)* of air at a lower kilowatt (kW) consumption [2.9].

*1 cfm = 28.32 m³/min

The efficiency of compressors determine their priority in the running schedules used in control strategies. This schedule lists which compressors can be used in parallel under specific conditions. For example, the demand for air during the evening when no production is taking place, is less than the demand during the day when there are production shifts scheduled. Hence, fewer compressors will be required to run during the evenings.

These control schedules are usually loaded into a Supervisory Control and Data Acquisition (SCADA) system that controls all the compressors supplying compressed air to the air ring. The SCADA system is usually installed at a central control node from where all the equipment and instrumentation connected to the communication network can be viewed and controlled.

2.3.3 Controlling the demand for air

Controlling air consumption on the demand side can be done on the surface or underground [2.8]. In general, a pressure-control valve will be implemented in the main surface-air line leading to the shaft. This valve will control the air flowing through it and so maintain a downstream pressure as per its predetermined set point.

Underground demand control is mainly achieved through:

- A simple open/close valve schedule that isolates the air supply when it is not needed; or
- a more complex pressure/flow control system similar to the surface pressure-control valve.

If an open/close schedule is implemented, the air lines leading to the work places are fitted with simple open/close valves. The most robust method of open/close control is when manual valves are installed on the air lines leading to the sections

and a personnel member is assigned to close the valves when a shift is over. The working personnel will reopen this valve when they re-enter the level for the next shift.

A more advanced method of control is when these valves are fitted with a clock-card system. All the underground personnel are then required to use clock cards to enter and exit the working sections. The valves will shut after the last person exits the section and reopen when the first person re-enters that section again. This system relies on all personnel to cooperate fully for the program to succeed.

A higher level of control can be achieved by controlling the valves from a central control node, such as a central control room. All valves are monitored, opened and closed via a communication network from the central control room. The control room operator receives notification that a specific section has been cleared and will then remotely close the isolating valve to that section.

Usually when the control and communication infrastructures are expanded to the point that a valve can be opened and closed from a central control room, a control valve is used. This valve will then control the airflow and air pressure delivered to a specified section. The advantage of a control valve over an open/close isolating valve is that the demand for compressed air can be controlled throughout the day.

There are various types of valves that can be used for controlling and isolating compressed air. Their uses, advantages, disadvantages and cost will be discussed in Chapter 3.

To continuously monitor the air pressure and airflow, pressure transmitters and airflow meters need to be installed in the air lines where the control valves are installed. This monitoring instrumentation gives feedback on the system parameters through the same communication network through which the control valve is controlled.

Another form of demand side control is to manage the air leaks in the system. Excessive air leaks can cause pressure drops of 20%–30% in the air lines leading

to the work places [2.11]. In poorly maintained air systems, the amount of compressed air lost through air leaks can increase to as much as 70% [2.6].

2.4 Cost of implementing a typical DSM project on compressed-air systems

The typical DSM project implemented on compressed-air networks at mines consist of various subcomponents and control strategies such as the ones discussed previously. The ideal scenario is to have automated control over the whole air network from a central point.

Each project is unique to the site where it is implemented and has to comply with the rules and regulations of that site. Because of this, no two projects are the same, which also causes the implementation cost per project to vary.

Table 5 lists some of the various components and infrastructure that can be found on a typical DSM compressed-air project.

Table 5: Site components

| | Description of infrastructure |
|--------------------|--|
| Supply side | <p>The supply side mainly consists out of the compressors and the compressor control instrumentation. Normally all the compressors and compressors controls are installed in a compressor house that houses and protects the infrastructure.</p> <p>A compressor can normally be stopped, started and controlled from its locally installed Programmable Logic Controller (PLC). If the compressor is automated, this control can be conducted remotely from a central control node.</p> <p>The relevant instruments measures a compressor's delivery pressure and flow. This information is relayed to the compressor controls to establish a closed-loop control circuit [2.12].</p> |

| | Description of infrastructure |
|-------------------------------------|--|
| Supply side (continued) | <p>If a compressor is automated, the running status and availability of the compressor is relayed to a central control node. This would allow the controller to select which compressor to run, based on predetermined control parameters.</p> |
| Demand side | <p>The demand side consists of all the compressed-air consumers and system losses that make up the total air consumption of the system.</p> <p>In some cases there are control valves installed at the delivery points to each compressed-air consumer that control the air supplied to that consumer. It is recommended that flow meters and pressure transmitters are installed with control valves used for this purpose.</p> <p>Depending on the communication infrastructure, the control of these valves can either be conducted locally or remotely from a central control node.</p> <p>To control a valve an actuator needs to be installed on the valve. Pneumatic actuators are cheaper to install when compared to the cost of electric actuators. However, pneumatic actuators are specified according to the available system air pressure, since it uses compressed air to actuate. The maximum system pressure will determine the size of the actuator and thus directly influence the cost of the actuator. Electric actuators are specified according to available supply voltage (e.g. 535 V).</p> |
| Communication infrastructure | <p>All the PLC's controlling field instruments are connected to a SCADA through a communication network.</p> <p>The communication network can consist of optical fibre or copper wire. The communication protocols used to communicate over these networks are dependant of the instrumentation and standards of the specific mine.</p> |

| | Description of infrastructure |
|----------------------------------|--|
| Measuring instrumentation | <p>The measured conditions of the air network are relayed back to the relevant control node to establish a closed-loop control circuit.</p> <p>Pressure transmitters return milli-ampere (mA) signals relevant to the measured air pressure. The controlling communication infrastructure (e.g. a PLC) connected to the transmitter are calibrated to calculate the air pressure relevant to the measured mA signal.</p> <p>Pressure transmitters are generic and can be installed on almost any size air line. Only the pressure range in which the transmitter must operate needs to be specified, since pressure transmitters are designed to be range specific.</p> <p>Airflow is measured by either a mass-flow meter or volumetric-flow meter. The choice in meter is dependent on the mine's specifications. Mass-flow meters are generally more expensive when compared to volumetric-flow meters of the same size.</p> <p>The advantage of installing a mass-flow meter over a volumetric-flow meter is that with the addition of a device (called a tri-loop splitter) a mass-flow meter can measure and relay the pressure and temperature of the compressed air as well. This is possible because a mass-flow meter needs to measure these parameters to calculate mass flow.</p> <p>Both mass-flow and volumetric-flow meters return a milli-ampere signal relevant to the measured airflow. Similar to pressure transmitters, these signals are converted and scaled by the monitoring communication infrastructure connected to each instrument to return a value relevant to the measured airflow.</p> <p>Flow meters are not only range specific, but also need to be sized according to the specific air line in which the instrument will be installed. The end of the flow meter's probe needs to be positioned at the centre of the air line to measure an accurate reading. Figure 9 illustrates this concept.</p> |

| | Description of infrastructure |
|--|--|
| Measuring instrumentation (continued) |  <p>Figure 9: Flow meter installation [2.13]</p> |

Table 6 lists the typical cost of the possible subcomponents of the infrastructure described in Table 5.

Table 6: Infrastructure costs

| | List of possible subcomponents/infrastructure | Cost* [ZAR] | Estimated installation time*** |
|-------------|---|-------------|--------------------------------|
| Supply side | <ul style="list-style-type: none"> • Installing a new compressor (>5 MW). • Full installation entails: <ul style="list-style-type: none"> ○ The compressor and electrical motor; ○ electrical switch gear; and ○ civil work. | 13,000,000 | 2 to 3 months |
| | <ul style="list-style-type: none"> • Installing a new compressor (<3 MW). <ul style="list-style-type: none"> ○ Complete unit. ○ Minimal civil work. | 7,500,000 | 5 weeks |
| | <ul style="list-style-type: none"> • Full compressor automation (basic controls** in order). | 3,000,000 | 1 month |
| | <ul style="list-style-type: none"> • Compressors upgrade with basic controls. | 3,500,000 | 1 to 2 months |
| | | | |

| | List of possible subcomponents/infrastructure | Cost* [ZAR] | Estimated installation time*** |
|-------------------------------------|---|-------------|--------------------------------|
| Demand side | • 250 mm globe control valve | 250,000 | 1 to 2 days |
| | • 250 mm butterfly valve | 50,000 | 1 to 2 days |
| | • 250 mm high-performance butterfly valve | 53,000 | 1 to 2 days |
| | • 250 mm valve flanges | 1,500 | 1 to 2 days |
| | • Electric actuator (525 V) | 85,000 | 1 to 2 days |
| | • Pneumatic actuator | 50,000 | 1 to 2 days |
| Communication infrastructure | • PLC (including commissioning) | 160,000 | 1 to 2 weeks |
| | • PLC programming | 12,500 | 1 to 2 weeks |
| | • SCADA (licence, development & commissioning) | 300,000 | 6 to 8 weeks |
| | • Optical fibre | 30/meter | n/a |
| | • Instrumentation copper wire | 10/meter | n/a |
| Measuring instrumentation | • Pressure transmitters for 0 kPa–700 kPa (including commissioning) | 6,000 | 1 day |
| | • Mass-flow meter for 250 mm air line (including commissioning) | 95,000 | 1 to 2 days |
| | • Volumetric-flow meter for 250 mm air line (including commissioning) | 50,000 | 1 to 2 days |
| | • Tri-loop splitter (including commissioning) | 15,000 | 1 day |
| | • Power meter (including commissioning) | 12,500 | 1 to 2 days |

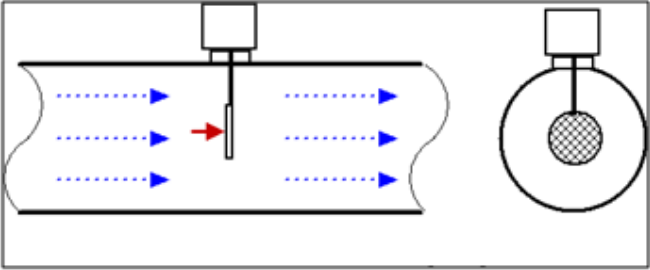
*The costs of these components were calculated using the actual cost of the components in 2010. It is also the average estimated cost for the given component. Conditions that are unique to the respective sites will influence the cost.

**Basic control in this case refers to the guide vane and surge controllers.

***Estimated installation time is based on installation periods of previous projects.

2.5 Conclusion

Typical consumers of compressed air; the cost of installing air supply- and demand side infrastructure; and possible strategies to save energy in compressed-air networks; have all been discussed in this chapter. From this information it is

clear that a detailed investigation into each proposed project is crucial to its success.

Some of the strategies that has to be investigated further when considering to implement a DSM project on a mine compressed-air system are listed below:

- Compressor automation;
- compressor prioritisation;
- optimal valve selection;
- infrastructure implementation location;
- leakage reduction;
- pressure losses in air lines; and
- alternative instrumentation.

These strategies will be investigated in Chapter 3 along with other less significant aspects that may be unique to the methods. All of these strategies need to be evaluated in terms of cost; time of implementation; and percentage contribution to the potential savings of the project. By quantifying these parameters it will be possible to determine the success or failure of implementing a cost- and time-efficient DSM project on mine compressed-air systems.

2.6 References

- [2.1] W. Booysen, M. Kleingeld, & J.F. van Rensburg, "Optimising compressor control strategies for maximum energy savings," *Energize*, pp.65, Jul. 2009.
- [2.2] R. Saidur, N.A. Rahim, & M. Hasanuzzaman, "A review on compressed-air energy use and energy savings," *Renewable and Sustainable Energy Reviews*, vol. 14, pp. 1135–1153, 2010.
- [2.3] Citizendium. (2010, September 11). *Gas compressor* [Online]. Available: http://en.citizendium.org/wiki/Gas_compressor

- [2.4] Cameron. (2010, September 12). *Why centrifugal compressors* [Online]. Available: http://www2.c-am.com/content/products/product_detail.cfm?pid=3063&bunit=cs#Features
- [2.5] B. Howe, & B. Scales, "Beyond leaks: Demand-side strategies for improving compressed air efficiency," in *National Industrial Energy Conference*, Houston, 1997, pp. 162–166.
- [2.6] J.N. Da La Vergne, *Hard rock miner's handbook*, 3rd ed. Ontario. McIntosh Engineering, 2003, p. 179, 182.
- [2.7] H. Nesor, "Energy savings through the automatic control of underground compressed air demand," M. Eng. dissertation, Dept. of Engineering, North-West University, Potchefstroom, South Africa, 2008.
- [2.8] J.W. Lodewyckx, "Investigating the effects of different DSM strategies on a compressed air ring," M. Eng. dissertation, Dept. of Engineering, North-West University, Potchefstroom, South Africa, 2007.
- [2.9] R.T. Terrell, "Improving compressed air system efficiency: Knowing what you really need," *National Industrial Energy Conference*, Houston, 1998, pp. 82–86.
- [2.10] Q. Hongbo, & A. McKane, "Improving energy efficiency of compressed air system based on system audit," *Lawrence Berkeley National Laboratory*, vol. 06, no. 13, 2008.
- [2.11] Compressed Air Challenge. (2010, September 11). *Compressed air system leaks* [Online]. Available: <http://www.compressedairchallenge.org/library/factsheets/factsheet07.pdf>
- [2.12] P.B. Meherwan, *Centrifugal compressors: A basic guide*, Tulsa. PennWell Corporation, 2003, p. 493.

- [2.13] Engineering Toolbox. (2010, September 12). *Target flow meters* [Online]. Available: http://www.engineeringtoolbox.com/target-flow-meters-d_497.html



**COST- AND TIME-
EFFICIENT CONTROL
STRATEGIES AND
PRINCIPLES**

Chapter 3

Development of cost- and time-efficient implementation strategies and the principles of the control methods.

3 CHAPTER 3: COST- AND TIME-EFFICIENT CONTROL STRATEGIES AND PRINCIPLES

3.1 Introduction

Various cost- and time-efficient control strategies can be implemented on mine compressed-air DSM projects. The focus will be on the selection of the optimised control instrumentation, planning for the exact location of control instrumentation and implementing alternative control strategies on compressed-air systems. Some of the principles behind these strategies will also be investigated.

One of the goals of this research is to find cost-effective alternatives to expensive control methods. Cost-effective control strategies are usually not the most energy efficient strategies when compared to the savings achieved by normal control methods, where the cost of implementation is not an issue. However, since these strategies can be implemented using a limited budget, they are an alternative to the expensive control methods.

Some of the strategies discussed in this chapter are ideal for implementation on DSM projects. Repairing air leaks; and upgrading compressors to operate more efficiently; are examples of some of the strategies that will aid in improving the efficiency of the entire compressed-air system. At the same time, significant improvements in the savings potential of the project will be realised.

The outcome of the proposed strategies is to have a DSM project implemented on a compressed-air system of a mine: in the shortest amount of time; and at the lowest cost; while still managing to achieve acceptable savings.

3.2 Identifying DSM project potential

Not all mines are in the financial position to install expensive infrastructure such as full compressor automation and extensive air-network control. These investments

are usually required to fully benefit from the Eskom DSM programme. For this reason, alternative methods are being investigated that will benefit both the mine and Eskom.

To identify a potential DSM project the following procedure with four general steps need to be followed:

Step 1: Identifying the electricity user with saving potential:

A viable method to ensure maximum savings is to select a mine, or section on a mine, with the largest installed capacity. Compressors are one of the largest consumers of energy on a mine. They typically use 21.3% of a mine's total electricity [3.1].

Thus, the mine with the greatest potential is often the one with highest installed capacity. This is however not always the case as some large energy consumers have little to no DSM potential (e.g. electricity management strategies are already in place or have been implemented during the commissioning of the mine).

Step 2: Determine the potential electrical and cost savings:

The next step would be to determine the potential savings for an identified project. An initial investigation is required to identify all the air consumers in the system; the required pressure at different times of the day; and the condition of the installed infrastructure.

Various onsite inspections and evaluations are required to obtain sufficient information on the system operations. These essentially consist of [3.1]:

- Different mining shafts (production shafts, pumping shafts or hoisting shafts);
- the minimum required system pressure;
- the daily pressure profile;
- the installed power and delivery flow capacity;

- the physical layout of the compressed-air system (surface and underground);
- existing consumption trends;
- type and number of compressed-air users;
- existing control strategy; and
- the installed infrastructure such pneumatic drills and loaders.

Part of such an investigation would be to test the response of the system conditions. By throttling already installed manual valves, the system response that would result from a control valve being installed at that location, can be simulated.

Knowing the system requirements and responses from the simulated control testing would allow for a potential saving to be calculated. This saving will be re-evaluated in detail at a later stage if the project appears to be viable.

During this phase the type of DSM project can also be identified. As mentioned in Chapter 1, there are three different types of DSM projects. The types of DSM projects and their typical applications are listed and discussed in Table 7.

Two major factors have to be considered to determine which particular type of DSM project would be viable for the proposed project:

- The potential savings that can be realised; and
- the type of installed infrastructure that will be investigated.

Step 3: Determine the total estimated infrastructure cost:

With the knowledge gathered from the initial investigation a general project scope can be compiled listing the essential infrastructure requirements to achieve the proposed saving. This document helps to estimate the cost of the required infrastructure needed for the DSM intervention.

Table 7: DSM projects

| | Load shifting | Load shedding (peak clipping) | Energy efficiency |
|---|---|---|---|
| Examples of typical applications | <p>The 24-hour energy consumption of these particular projects remains constant. A typical application of a load-shifting project is on water-pumping projects.</p> <p>The water that is usually pumped during peak periods is stored in storage dams during the Eskom peak periods. During off-peak periods the water is pumped to the surface. The same amount of energy is still being used to pump the same amount of water, but only during different times of the day. This implies that electricity is being used in more cost-efficient time slots.</p> <p>This method is not practical on a large scale as it is difficult/impractical to store compressed air.</p> <p><i>(continued on next page)</i></p> | <p>To achieve load shedding the electricity demand during Eskom evening peak period needs to be reduced. A typical application of load-shedding projects is where the supply pressure, and demand for compressed air in compressed-air networks, are minimised during Eskom evening peak periods.</p> <p>This is done by installing various pressure control equipment and introducing energy saving strategies to the mine. A reduction in the demand implies a reduction in the supply, that in turn will result in an energy saving with a typical load graph as the one depicted in Figure 11.</p> <p><i>(continued on next page)</i></p> | <p>A typical energy-efficient load profile is depicted in Figure 12. To achieve this type of saving every subcomponent of the relevant network has to be investigated and evaluated.</p> <p>The typical investigation into an energy efficient compressed-air project will review the demand and supply side of the compressed-air network.</p> <p>By reducing the wastage of compressed air through fixing leaks and addressing overpressurisation, the demand side can be optimised.</p> <p><i>(continued on next page)</i></p> |

| | Load shifting | Load shedding (peak clipping) | Energy efficiency |
|---|--|---|---|
| Examples of typical applications (continued) | Figure 10 depicts a typical energy load graph against a baseline for load-shifting projects. | Compressor controls are usually automated as part of these projects. Automated compressors can be remotely stopped-and-started from a central control node. This makes the achievable savings more sustainable. | Pressure-control valves can be installed to control the air consumption of every compressed-air consumer. Furthermore, the compressors on the supply side can be automated and their efficiencies can be evaluated to determine the most efficient running schedules dependent on the demand for compressed air. |
| Typical 24-hour usage | <p>Figure 10: Load shifting representation</p> | <p>Figure 11: Peak clipping representation</p> | <p>Figure 12: Energy efficiency representation</p> |

Step 4: Evaluate the cost per MWh and determine the payback period:

With the estimated cost of the required infrastructure and the proposed saving derived from the initial investigation the cost per megawatt-hour can be determined. Because energy saving projects is unique to the implementation sites, no two projects are the same. The only way to compare these projects is to compare their cost per megawatt-hour and their payback period after implementation.

Another essential part of identifying the financial benefit of a project is to calculate the payback period after implementation. Over a period of time the project must generate enough savings from the cost savings on electrical bills to cover all the expenditures of the new implementation. This period is called the payback period. If the total payback period does not fall within the lifespan of the mine, the project is not viable.

The ideal situation is to implement a project with adequate savings potential so that the initial infrastructure is paid back in a relatively short time when compared to the lifespan of the mine.

Identifying a DSM project with enough savings potential is as crucial as identifying one with acceptable implementation costs. The proposed instrumentation for a project is dependent on the client's budget or the subsidy granted by Eskom based on the potential savings.

3.3 Compressor control

Automation of the compressors is essential to obtain maximum savings [3.2]. This entails features such as automatic set point control, automatic stop-and-start and remote monitoring. This automation infrastructure is costly and does not always fit within the budget of a DSM project.

The two main controls methods for basic centrifugal compressors are:

- Guide vane control; and
- blow-off control.

The control infrastructure is usually controlled by a PLC or Moore controller that is located close to the compressor.

The guide vane or variable inlet valve on the intake side of a compressor regulates the mass-flow of air through the compressor. Should the system pressure exceed the compressor pressure set point, these flow control instruments will reduce the flow of air through the compressor to allow the system pressure to decrease as compressed air is consumed [3.3].

The compressor blow-off controller will only engage to prevent the compressor from surging. This will happen in the event where the system pressure increases above a predetermined critical set point (that is higher than the normal compressor set point) and the guide vane controller was not successful in reducing the pressure.

A compressor will surge if the system pressure exceeds the discharge pressure of the compressor and cause the normal forward flow of air through the compressor to be reversed. Surging causes damage to the compressor through pressure shocks, high vibrations and rapid increase of temperature [3.5].

To prevent surging, the system pressure is reduced by rapidly opening the blow-off valve to allow compressed air to escape into the atmosphere. Once the pressure is normalised the blow-off valve is closed and the pressure control is handed back to the guide vane controller.

Figure 13 depicts a compressor map of a typical centrifugal compressor. The surge line is the curve that starts in the lower left-hand corner and continues to the top of the graph. For explanatory purposes, the surge line is marked red. The region to the left of the surge curve is where the compressor is unstable. Ideally,

the compressor would be operated as close as possible to the right of the surge line to run the compressor as efficiently as possible.

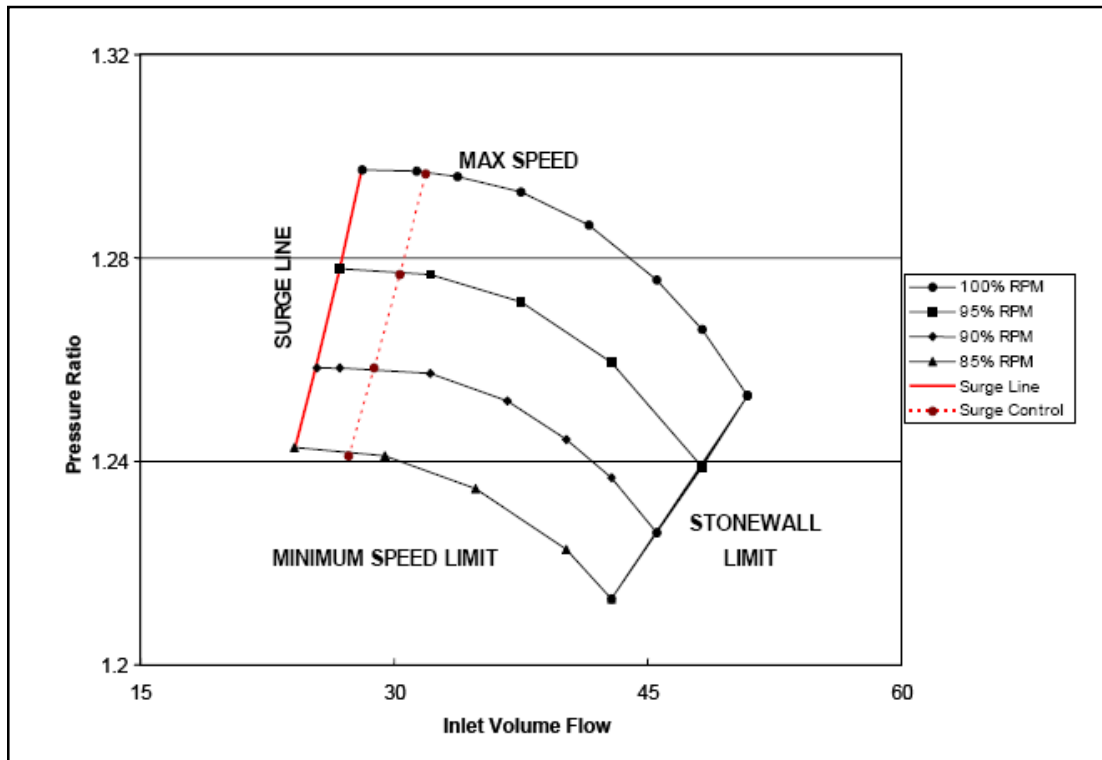

Figure 13: A typical compressor map illustrating the surge line [3.6]

Compressor blow-off must only be considered as a last resort because of the huge loss of available energy when the work done to compress the air is simply blown off into the atmosphere.

In worst case scenarios the compressor guide vane controls may be damaged or out of order. The system pressure is then maintained by an operator who continuously monitors the system pressure. The operator manually stops and starts compressors to prevent overpressurisation that will cause the compressors to blow off or surge.

Due to the lack of proper maintenance some old compressors are never stopped. If they are stopped it is hard to get them running again, because of vibration issues at different rotational speeds that causes the compressor to trip during start-up.

In instances where the demand for compressed air can drastically increase (as at the start of a production shift) this would not be ideal. To keep the system pressure stable and be able to adhere to the system demand, these older compressors are kept running in an off-load mode.

To run a compressors in off-load mode, the guide vanes are closed to the minimum opening and the blow-off on the particular compressor is opened. This causes a compressor running in an off-load mode to consume less electrical energy when compared to onload operation.

A low-budget strategy is to repair and refurbish the basic compressor controls such as the guide vanes, guide vane controller and the blow-off controller of these compressors. To utilise the controls and change the discharge pressure set point of the compressor from a remote location, low cost network communication devices can be installed.

Although this solution still requires the compressor to be stopped and started manually, the running control of the compressor can be done from a central location such as a control room.

3.4 Energy saving resulting from valve control

System airflow can be controlled by means of a variable opening throttle valve installed in an air line. The throttled valve causes a lower pressure and reduced airflow downstream from where the valve is installed. Restricting the flow of air causes a pressure build-up on the upstream side of the valve. To neutralise the pressure build-up the compressor guide vanes will cut back, reducing the mass-flow through the compressor, resulting in electrical energy saving on the compressors.

The minimum- and maximum pressure set points for a specific control valve will depend upon the operational requirements of the compressed-air consumers on

the demand side. Accurate information on the operational parameters of the system components is essential to the valve design specification as well as the valve control strategies.

Air pressure- and air flow measuring instrumentation must be installed as an integral part of the DSM implementation. This will allow for continuous monitoring of pressures and airflow in the air supply lines. The control schedules for the control valves can be set up using the information obtained from the installed measuring equipment.

A control valve, such as a globe valve or high-performance butterfly valve, is an ideal valve when continuous control is required. These valves regulate the supply pressure to the demand side by varying the valve opening. A controlled valve opening will only allow a predetermined amount of air past the valve.

Some sections on the demand side only require compressed air during certain times after which the air supply to that sections can be completely shut off. In such cases, butterfly valves are preferably used. The purpose of this cost-effective valve is to either isolate the section in question, or to allow air to flow uncontrolled to the section.

3.5 Effects of line friction

Air flowing over a long distance will be subject to relatively large pressure losses as a result of line friction. The concept of line friction in a perfectly round pipe, as the ones found in the compressed-air networks discussed in this study, and the principles relevant to air flowing through these pipes, will be discussed in this section.

The first concept that needs to be understood is that the flow pattern of a medium flowing through a pipe varies. There are two types of airflow: laminar and turbulent flow. Table 8 summarises the descriptions and illustrations of these two types of flow.

Table 8: Flow types

| | Laminar flow | Turbulent flow |
|--------------------|---|---|
| Description | <p>Laminar flow occurs at low velocities. As the viscosity of the medium increases, the velocity by which laminar flow would occur could also increase.</p> <p>Under laminar-flow conditions, the medium would flow in concentric circles following a straight path. There is also little to no mixing between these concentric levels. Figure 14 illustrates a manner to visualise laminar flow in a cylindrical pipe.</p> <p>In an experiment, dark dye is introduced into the medium flowing in a pipe. As long as the flow remains laminar the dye will not mix with the rest of the medium and follow the path of the level it is injected in.</p> | <p>Turbulent flow occurs when a medium is flowing at a high velocity. It differs from laminar flow in that there is no pattern in the medium. The appearance of the medium under these conditions is described as chaotic.</p> <p>Figure 15 illustrates an experiment where dye is introduced into a pipe where the medium is experiencing turbulent flow.</p> <p>As can be seen from Figure 15, the dye is almost immediately dispensed throughout the medium.</p> |

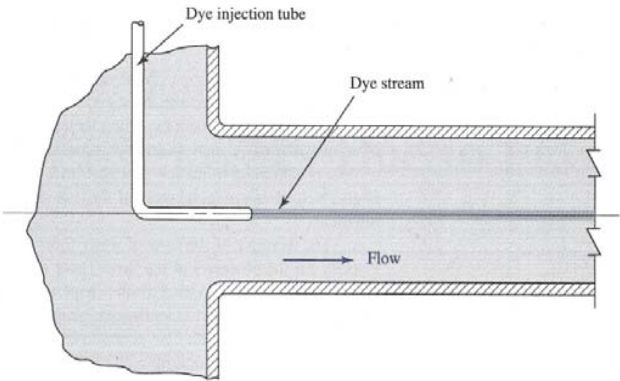
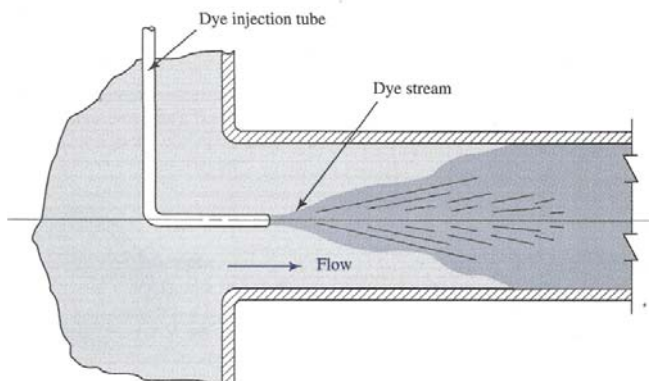
| | Laminar flow | Turbulent flow |
|--|---|--|
| Graphical representation |  <p>The diagram shows a cross-section of a pipe with a dye injection tube on the top wall. A dye stream is injected into the center of the pipe. The flow is laminar, meaning the dye stream remains a single, smooth line that gradually widens as it moves downstream. An arrow labeled 'Flow' points to the right.</p> <p><i>Figure 14: Laminar flow [3.7]</i></p> |  <p>The diagram shows a cross-section of a pipe with a dye injection tube on the top wall. A dye stream is injected into the center of the pipe. The flow is turbulent, meaning the dye stream disperses and mixes with the surrounding fluid, creating a cloud-like shape that spreads across the pipe. An arrow labeled 'Flow' points to the right.</p> <p><i>Figure 15: Turbulent flow [3.7]</i></p> |
| Typical Reynolds number (discussed on page 48) | $N_R < 2000$ | $N_R > 4000$ |

Air density:

Air density is calculated using the following formula [3.11]:

$$\rho = \frac{p}{RT} \quad (3.1)$$

Where the variables are:

- Density - ρ $[\text{kg}/\text{m}^3]$;
- temperature - T $[\text{K}]$;
- absolute pressure - p $[\text{N}/\text{m}^2]$; and
- individual gas constant - R $[\text{N} \cdot \text{m}/\text{kg} \cdot \text{K}]$.

The individual gas constant for air is $287 \text{ N} \cdot \text{m}/\text{kg} \cdot \text{K}$ at $25 \text{ }^\circ\text{C}$ and 101 kPa [3.11].

Reynolds number:

The Reynolds number is a non-dimensional number used to predict the type of flow without having to observe the medium [3.7].

The Reynolds number of a medium can be determined by using the following four variables:

- Density - ρ $[\text{kg}/\text{m}^3]$;
- dynamic viscosity - η $[\text{Pa} \cdot \text{s}]$;
- pipe diameter - D $[\text{m}]$; and
- average velocity - v $[\text{m}/\text{s}]$.

Using these variables, the dimensionless Reynolds number N_R can be calculated:

$$N_R = \frac{vD\rho}{\eta} \quad (3.2)$$

As mentioned in Table 8, the two types of flow can be distinguished using the Reynolds number. For a Reynolds number < 2000 the flow can be accepted as being laminar and for a Reynolds number > 4000 the flow is accepted to be turbulent [3.7].

It is impossible to predict the type of flow in the range 2000–4000. For this reason this range is called the *critical range*. Depending on the viscosity of the medium and the disturbances causing turbulent flow, the changeover from laminar flow to turbulent flow could happen at any time in this range [3.7].

Darcy's equation for energy losses:

In the general energy equation, h_L is defined as the energy loss from a system. Darcy's equation can be used to calculate the energy loss resulting from friction in a straight, round section of pipe. The equation can be expressed as [3.7]:

$$h_L = f \times \frac{L}{D} \times \frac{v^2}{2g}, \quad (3.3)$$

Where the variables are defined as:

- Energy loss due to friction - h_L $[N \cdot m];$
- length of the flow stream - L $[m];$
- pipe inside diameter - D $[m];$
- gravitational acceleration - g $[m^2/s];$
- average velocity - v $[m/s];$ and
- friction factor - f $[dimensionless].$

Friction factor for laminar flow:

To calculate laminar flow the *Hagen-Poiseuille equation* can be substituted into *Darcy's equation for energy loss* to derive the equation for the friction factor of laminar flow:

$$f = \frac{64}{N_R} \quad [\text{dimensionless}] \quad (3.4)$$

Refer to the Appendix for the derivation. The *Hagen-Poiseuille equation* used in this derivation can be expressed as [3.7]:

$$h_L = \frac{32\eta L \nu}{\gamma D^2} \quad (3.5)$$

Where the variables are defined as:

- Energy loss due to friction - h_L $[N \cdot m]$;
- length of the flow stream - L $[m]$;
- pipe inside diameter - D $[m]$;
- specific weight - γ $[kN/m^3]$,
- average velocity - ν $[m/s]$; and
- dynamic viscosity - η $[Pa \cdot s]$

Friction factor for turbulent flow:

It is difficult to determine the friction factor of a medium experiencing turbulent flow. Experimental methods are mostly used to determine f for a specific situation. The friction factor is dependent on two factors [3.7]:

- The Reynolds number (N_R); and
- the relative roughness of the pipe (ε).

Figure 16 illustrates what is meant by the relative roughness of a pipe.

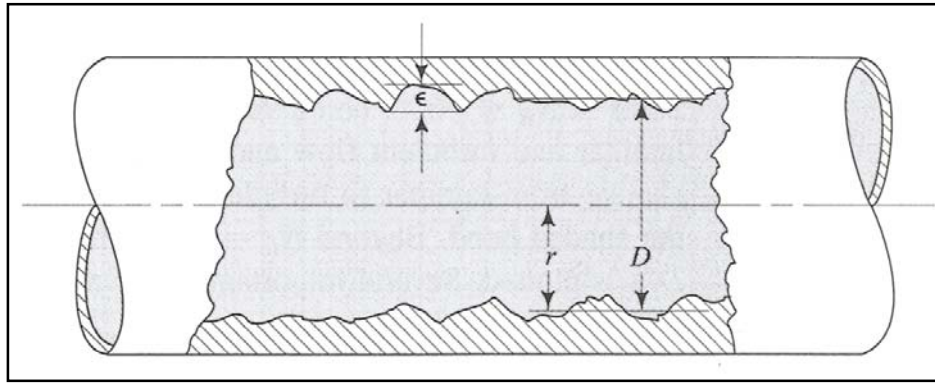

Figure 16: Relative roughness of a pipe [3.7]

The pipe-roughness design values of some of the materials used to manufacture pipes are listed in Table 9.

Table 9: Pipe roughness design values [3.7]

| Material | Roughness (ε) (m) |
|----------------------------------|---------------------------------|
| Glass | Smooth |
| Plastic | 3.0×10^{-7} |
| Drawn tube: copper, brass, steel | 1.5×10^{-6} |
| Steel, commercial or welded | 4.6×10^{-5} |
| Galvanised iron | 1.5×10^{-4} |
| Ductile iron-coated | 1.2×10^{-4} |
| Well made concrete | 1.2×10^{-4} |
| Riveted steel | 1.8×10^{-3} |

The roughness factors listed in Table 9 gives a good indication of what the internal roughness of a pipe is when it is new. However, when calculating the roughness of pipes that has been in use for some time, these factors can only be used as estimates since the effects of rust and corrosion in the pipes will increase the roughness of the pipes.

The roughness factor can be calculated as:

$$\text{roughness factor} = \frac{\varepsilon}{D} \quad [dimensionless] \quad (3.6)$$

The variables are defined as:

- Roughness - ε [m]; and
- the pipe's inside diameter - D [m].

Using the roughness factor and the Reynolds number the friction factor f can be read off the Moody diagram shown in Figure 17. Alternatively it can be calculated using the *Colebrook* equation [3.8] that follows in Figure 17.

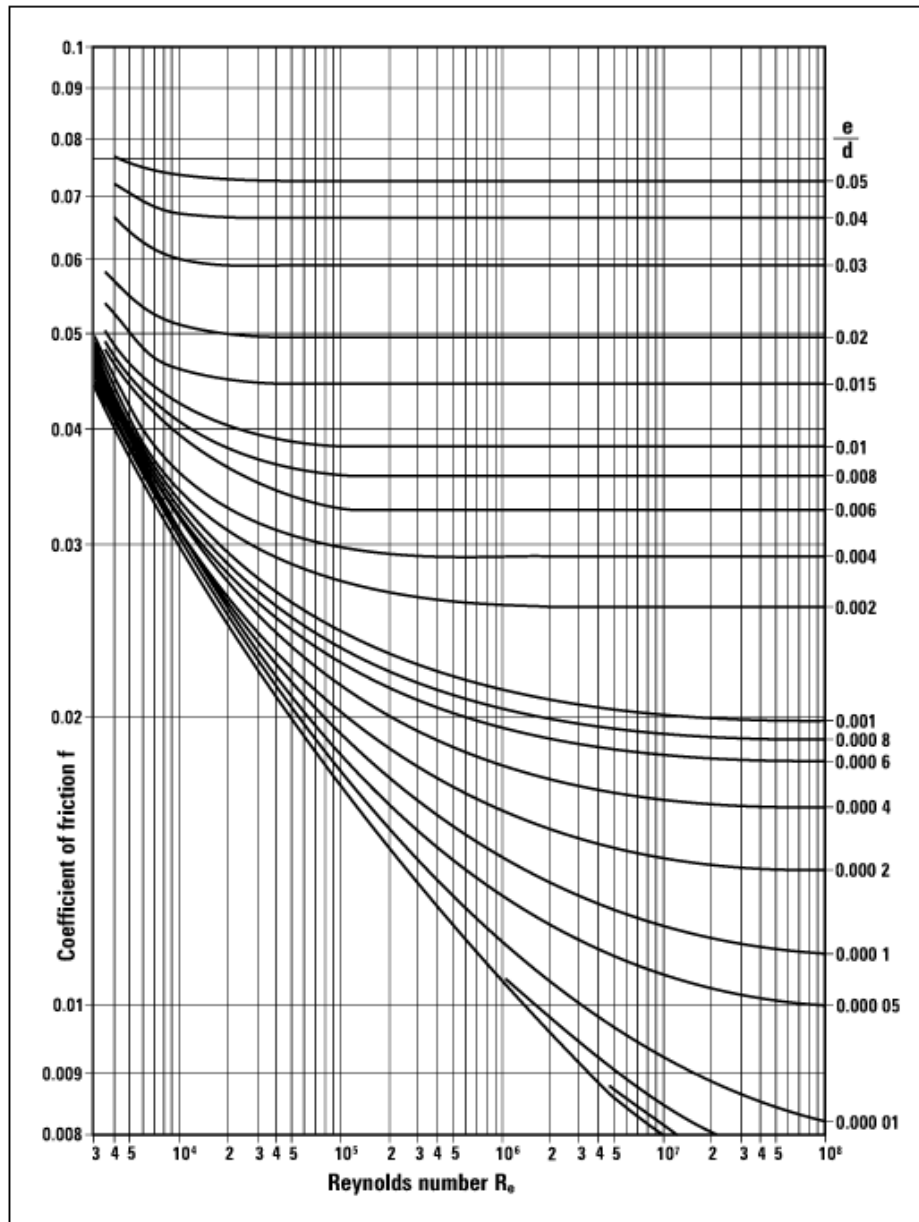

Figure 17: Moody diagram

If the friction factor f is not read off the Moody diagram (Figure 17), it can be calculated using the *Colebrook* equation [3.8]:

$$f = \frac{1.325}{\left[\ln \left(\frac{\varepsilon}{3.7D} + \frac{5.74}{N_R} \right) \right]^2} \quad (3.7)$$

Where the variables are defined as:

- Friction factor - f *[dimensionless];*
- the Reynolds number - N_R *[dimensionless];*
- roughness - ε *[m];* and
- the pipe's inside diameter - D *[m].*

Equation for pressure loss:

The loss of pressure, $\Delta p = (p_1 - p_2)$, can be calculated using Equation 3.8 [3.9]:

$$\Delta p = f \frac{l}{m} \frac{\rho v^2}{2} \quad (3.8)$$

Here m is the hydraulic mean radius. When applying the equation to a circular pipe, as is the case is in this study, it is accepted that $m = \frac{d}{4}$. The equation for Δp can then be written as:

$$\Delta p = 4f \frac{l}{d} \frac{\rho v^2}{2} \quad (3.9)$$

Where the variables are defined as:

- Loss of pressure - Δp *[kPa];*
- density - ρ *[kg/s];*
- pipe diameter - d *[m];*
- pipe length - l *[m];*

- average velocity - v [m/s]; and
- friction factor - f [dimensionless].

Practical implementation of these equations:

With the help of these formulas the expected pressure drop across a length of pipe can be determined. This will help in selecting a control valve for a specific application. To select a control valve the following must be specified:

- The medium that has to be controlled;
- the flow through the valve; and
- the pressure drop across the valve.

The ability to calculate the pressure drop resulting from line losses will aid in choosing the correct control valve.

The cost of a pressure-control valve increases as the pressure difference across the control valve increases. This is because tougher and more expensive materials are used to manufacture the internal components of the valve. It is necessary because the increased pressure difference across the valve will result in an increased airflow through the valve. The high velocity air is very corrosive and will cut away the valve's internal components if they cannot resist it.

The difference in pressure (ΔP) over a control valve can be calculated as:

$$\Delta P = \text{Supply pressure } (P_{\text{supply}}) - \text{demand pressure } (P_{\text{demand}}) \quad [\text{kPa}] \quad (3.10)$$

Using the equations discussed in the section, the pressure loss (P_{loss}) resulting from the line losses can be calculated. Adding the calculated P_{loss} to the known P_{demand} will result in a smaller ΔP and as explained earlier, this will result in a cheaper valve required for the specific application.

3.6 Alternative control strategies



3.6.1 Valve selection

The use of pressure-control valves allow for DSM control strategies to be implemented on air networks. It is imperative to select the correct valve to obtain an acceptable level of controllability, noise and life span expectancy. Table 10 lists three of the most popular valves used to control air pressure; their characteristics; typical applications; and the relative cost of each valve (assuming unity cost for the high performance butterfly valve).

Valve corrosion may occur when the valve is at a small-percentage opening. The velocity of the air passing through the valve is increased to a point where the static pressure falls below the vapour pressure of the air. The compressed air used in mines is not filtered and thus can contain moisture and small particles. Moisture particles condense and begin to erode the disk and valve seat in the valve. This is a frequent occurrence when using these valves to control mine compressed air.

A control valve is designed for a specific pressure drop across the valve. This pressure drop will result in a specific maximum and minimum velocity of air flowing through the valve. If the maximum pressure (as per valve design) is exceeded, it will cause the valve to generate more noise due to the increased velocity of the airflow through the valve. The higher velocity of the airflow through the valve can also damage the internal seals and components of the valve.

Table 10: Valve types

| Type of valve | Globe valve | Butterfly valve | High performance butterfly valve |
|------------------------|---|---|---|
| Graphical illustration |  <p data-bbox="558 802 915 834">Figure 18: Globe valve [3.10]</p> |  <p data-bbox="1020 802 1409 834">Figure 19: Butterfly valve [3.12]</p> |  <p data-bbox="1514 802 1871 878">Figure 20: High performance butterfly valve [3.13]</p> |
| Characteristics | <p data-bbox="506 919 957 1230">Globe valves are high quality control valves. The specific design of this valve is versatile. An installed valve body can be optimised for the system parameters by only interchanging some internal components.</p> <p data-bbox="506 1247 814 1279"><i>(continued on next page)</i></p> | <p data-bbox="984 919 1436 1279">Butterfly valves cost much less than the other two valves discussed in this table, but they are not as versatile or durable. If a butterfly valve is operated outside of its design control parameters, problems such as corrosion and excessive noise start to occur [3.4].</p> | <p data-bbox="1461 919 1913 1182">The altered butterfly valve design allows the valve to be more corrosion resistant than a normal butterfly valve. The altered design has the added benefit of being more affordable than globe valves.</p> <p data-bbox="1461 1247 1770 1279"><i>(continued on next page)</i></p> |

| Type of valve | Globe valve | Butterfly valve | High performance butterfly valve |
|------------------------------------|---|---|---|
| Characteristics (continued) | <p>The most crucial internal components are known as the trim. Each trim is designed for a specific application. The focus of these designs is to reduce noise and the effects of cavitations and erosion. Figure 21b and Figure 21c illustrate examples of such trims. Figure 21a illustrates a cutaway view of an installed trim.</p> | | <p>Installing a high-performance butterfly valve over a normal butterfly valve will increase the service life span of the valve.</p> <p>This valve should also only be operated within the design system parameters to avoid damage to the valve caused by increased airflow through the valve.</p> |
| Typical applications | <p>The trim designs damp the noise generated when airflow through the valves is restricted allowing for these valves to be installed close to everyday work places.</p> | <p>These valves are ideally used for open/close applications.</p> <p>However, they may be used as control valves in situations where excessive noise is not an issue.</p> | <p>These valves are used as an alternative control valve when globes valve cannot be afforded.</p> <p>As with standard butterfly valves, these valve also generate excessive noise when restricting the flow of air.</p> |
| Unity cost | 5 | 0.8 | 1 |

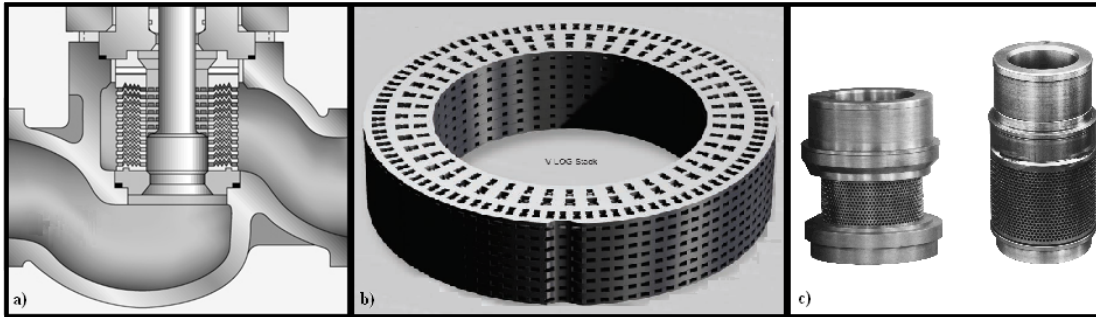

Figure 21: a) Globe valve trim installed; b) Stack trim; c) Whisper trim

The internal components of globe valves can be altered to operate under the new system parameters should the maximum system parameters increase due to a permanent increase in demand. The original valve body is left in the air line and only the internal components are changed. Valves with fixed internal components, such as butterfly valves, need to be replaced with a larger valve to deal with a permanent increase in demand.

3.6.2 Compressor prioritising

An industrial compressed-air network usually comprises two or more compressors. In most cases these compressors differ regarding their installed capacity and efficiency [3.14].

To establish prioritised compressor control, the efficiency of each compressor must be determined. The compressor manufacturing company, or a private company accredited by the manufacturer, can test and determine the efficiency of each of the compressors.

Ideally, the more efficient compressors must be started first and brought into operation before a less efficient compressor is used. If the compressors are fully automated, this priority schedule can easily be programmed into the SCADA or PLC that is controlling the compressors.

In instances where the compressors are not automated, a possible cost-efficient DSM strategy is to implement a monitoring system that will inform the compressor operator when and which compressor to stop-and-start. The REMS CM

(Real-time Energy Management System, Compressor Manager) platform developed by HVAC International (Pty) Ltd has been designed to perform this function [3.15].

The REMS CM software requires minimal communication infrastructure and a small computer server. Minimum system requirements include low-cost instruments such as a pressure transmitter on the main air columns and power meters on the compressor motors.

If the status of the air network (at a particular TOD) is known, the REMS CM software can notify the operator which compressors to run at which set points. This strategy allows the compressor operator to efficiently maintain the required air pressure in the compressed-air network.

3.6.3 Selection of implementation locations

Meticulous selection of the implementation sites will also ensure cost and time savings. Time constraints make implementing DSM underground or on the shaft difficult. This is because of limited accessibility as a result of, for example, hoist schedules which are governed by the mine production schedules.

Installing the control valves on surface and away from the mine shaft provides accessibility to work areas that are not governed by the restraints mentioned above.

The South African Mining and Mineral policy determines that no work is allowed on Sundays except for maintenance [3.16]. These regulations apply to all working areas on a mine, thus allowing for one day in the week when the compressors can be stopped.

Choosing the implementation location in close proximity of existing mine communication- and electrical power networks, will save cost and time by not having to expand the existing networks. The cost and time savings will be achieved by not having to supply and install extra cabling, cable racking, additional hardware and labour for installation.

Piggybacking on the existing systems has the added benefit of compatibility and familiarity to the client. Instrumentation technicians do not have to spend time familiarising themselves with new communication protocols. Use of existing protocols ensures that the new instrumentation will be compatible with the existing network.

Compatibility of components will also be ensured. If a problem should occur with the installed infrastructure, the required spares could be sourced from back-up instruments in the onsite storerooms. This eliminates the loss of savings due to lengthy delivery periods.

Correct valve location is essential to ensure efficient valve control. Pressure-control valves must be installed downstream of the permanent high-pressure equipment. This will allow the control valve to modulate when lower pressure is required downstream from the valve location.

A gold plant is an example of a permanent high-pressure air consumer. High pressure at a low airflow rate is required for instruments such as pneumatic valve actuators. Installing the pressure-control valve downstream from the air line supplying compressed air to the gold plant, will allow the downstream pressure to be reduced while the minimum upstream pressure, and pressure supplied to the gold plant, remains unchanged.

3.6.4 Repairing of leaks

Air leaks can be defined as any opening where compressed air is unintentionally, or without authority, released into the atmosphere.

Energy savings can also be realised by repairing the air leaks on a compressed-air system. Excessive air leaks can cause pressure losses of 20%–30% in the air supply lines leading to the work places [3.17]. In poorly maintained systems, the amount of compressed air lost through air leaks can increase to as much as 70% [3.18].

The discharge pressure set point of the compressors needs to be set at a higher pressure to overcome the effect of pressure losses through air leaks. The higher pressure set point requires the compressors to consume more energy to satisfy the increased demand in the compressed-air pressure.

Table 11 lists the cost implications of a case study that were conducted by Mr A Garbers at an AngloGold mine. The results are an indication of what will happen if air leaks are left unattended. All the calculations were done with an assumed system pressure of 500 kPa. The calculations for these savings are shown in the Appendix.

Table 11: Cost of air leaks

| Size of hole [mm] | Airflow lost | | Cost per month* (ZAR) |
|-------------------|---------------------|----------|--------------------------|
| | [m ³ /s] | cfm | |
| 1 | 0.001 | 2.11 | 61.76 |
| 5 | 0.017 | 36.02 | 1,544.08 |
| 10 | 0.067 | 141.97 | 6,176.32 |
| 50 | 1.673 | 3544.89 | 154,407.93 |
| 100 | 6.693 | 14181.66 | 617,631.74 |

* Cost calculated using electricity price of R 0.40/kWh

Locating, recording and fixing all the leaks on underground supply lines is a time-consuming exercise. A quick method to solve this problem is to isolate the problem sections by installing open/close isolating valves on the air lines feeding these problem sections. The air flowing to that section can be restricted, allowing the air pressure in the rest of the air system to be maintained at the required pressure.

3.6.5 Selecting alternative measurement instrumentation

Mass-flow meters are the preferred airflow meters to install in a compressed-air network. The instrument measures air velocity, air pressure and air temperature to determine only the air mass flow at the point of measurement. With the addition

of a device called a tri-loop splitter, air pressure- and air temperature measurement at the point of measurement can also be obtained from the instrument.

Volumetric-flow meters are on average 50% less expensive than mass-flow meters. However, a volumetric-flow meter only measures the velocity of the air passing the point of measurement. To measure the air pressure and air temperature at the same point, a pressure transmitter and temperature probe have to be installed as well.

In most cases, the air temperature is not used as a variable when controlling compressed-air networks. Referring to Table 6 (that lists the typical cost of these meters) an alternative installation to a mass-flow meter would be to install a volumetric-flow meter in conjunction with a separate pressure transmitter. Depending on the size of the air line this will constitute a potential saving of R50,000 when compared to the installation of a mass-flow meter. These calculations are based on the cost of equipment for a 250 mm air line.

Installing a volumetric-flow meter and pressure transmitter instead of only a mass-flow meter, may have an effect on the project's implementation time, depending on the number of instrumentation that has to be installed. The physical installation of a single instrument (flow meter or pressure transmitter) takes less than an hour.

If there are only one or two pairs of volumetric-flow meters and pressure transmitters that need to be installed, it will have little to no effect on the project schedule. However, if there are 15–20 pairs, it may add a day or two to the total project implementation time.

3.6.6 Alternative methods to control field instruments

A communication network is required to control instrumentation, such as the valve actuators installed on valves in the field. The control commands are usually derived from the system's parameters at that specific time and relayed to the actuator in real time.

However, some mines do not have a communication network installed that extends all the way to where the instrumentation has to be installed. Installing the infrastructure required for such a network is extremely expensive and usually not feasible for projects where there are cost constraints.

An alternative solution to this problem is to use timer-based controls. This method does not allow for the option to control instrumentation continuously, because the installation is isolated from the rest of the communication network.

What this method does allow however, is consistent and periodic control of a particular variable at a known point in the system. The timer-based controller's control schedule is loaded into the central control node's database, which allows this controller to anticipate the effect of the timer-based control. The instrumentation that is controlled in real time from the central control node can be adjusted to anticipate the changes that will result from the timer-based control.

A simple example of this method is to use a timer to control an open/close actuator on a valve. This will result in the valve isolating the air line for specific periods during a day.

This is a very crude method of control, but it is more cost efficient to install, and much faster to implement, as opposed to implementing a communication network. This is especially the case if the communication network has to be extended to underground sections.

3.6.7 Alternative communication modules

PLCs are preferably used to control and communicate with field instruments. However, this could also be an expensive piece of equipment especially if there are several control and monitoring points where PLCs are required.

A cost-efficient alternative to installing a PLC at each location where control and communication is required, is to install a remote communication device. An example of such a device is the Moxa remote input/output (I/O) communication module [3.19] or the Siemens ET200 remote I/O communication module [3.20].

These devices have the ability to communicate with field instruments and connect to the existing communication network.

Instead of installing a PLC at each location where instrumentation has been installed, only one PLC is required at a central location. The PLC is then used to control and communicate with all the field instruments through the remote communication modules.

Some remote communication modules, such as the Moxa remote I/O module can be calibrated to convert the signal it receives from the field instrument into the required unit of measurement. Instead of relaying this information back to a PLC, the information can be relayed directly to a central control node. This is not the preferred method of operation but because the cost of a PLC is excluded from the project, it can be used as a cost-effective alternative.

3.6.8 Converting equipment from pneumatic to hydraulic

In some instances it is not possible to reduce the pressure of a compressed-air system because the equipment used at different times during the day all require the same minimum pressure.

The equipment is equipped with pneumatic pistons and uses compressed air during the period in which the energy savings have to be achieved. To overcome the problem the equipment can be converted to rather use hydraulic powered pistons instead of the pneumatic pistons [3.21].

By making use of hydraulic power packs and replacing pneumatic pistons with hydraulic pistons, the equipment in question can be isolated from the compressed-air ring. This is usually the case with pneumatic ore loaders that are being used during the Eskom evening peak period.

The pressure required by these loaders usually determines the minimum system pressure during the evening period. Converting these loaders to use hydraulic pistons will create an opportunity to lower the system pressure even further during the Eskom evening peak period.

3.7 Conclusion

Different DSM compressed-air strategies have been discussed in this chapter. The focus behind all these strategies is cost- and time savings. There are alternative strategies to some of those discussed that will further optimise the savings potential of the DSM project, but at a far greater cost.

Repairing the leaks and placing the correct control valves at strategic positions are basic strategies that must be implemented as part of any compressed-air project. Where cost is not a constrain, automation of the compressed-air system is usually implemented. This study has concentrated more on cost-sensitive systems which will only allow for manual operation.

Control systems such as REMS CM can make use of only the essential metering instrumentation. These instruments give feedback to the compressor operator and allow for manual control of the compressors and the compressed-air system. If the REMS CM instructions are properly followed, optimal conditions can be achieved to produce the maximum achievable energy savings. However, the better the automation the better savings will be achieved and sustained.

3.8 References

- [3.1] H. Nesor, "Energy savings through the automatic control of underground compressed air demand," M. Eng. dissertation, Dept. of Engineering, North-West University, Potchefstroom, South Africa, 2008.
- [3.2] W. Booysen, M. Kleingeld, & J.F. van Rensburg, "Optimising compressor control strategies for maximum energy savings," *Proceedings of Industrial and Commercial Use of Energy (IUCE)*, Cape Town, 2009.

- [3.3] R.A. Gutzwiller, R.J. Gerhart, & H.N. Hickok, "A 10,000-hp AC adjustable-frequency compressors drive: The economics of its application", *IEEE Transactions on Industry Applications*, vol. IA-20, no. 1, pp. 82, Jan./Feb. 1984.
- [3.4] The Fisher Company, *Control Valve Handbook*, 4th ed. 2005, p.136, 137.
- [3.5] D. E. Ventzas, G. Petropoulos, "Industrial compressor anti-surge computer control," *World Academy of Science, Engineering and Technology*, vol. 34, pp. 7–10, 2007.
- [3.6] K. Brun & G. Marybeth, *Guideline for field testing of gas turbine and centrifugal compressor performance*, 2nd ed. San Antonio. Southwest Research Institute, Gas machinery research council, 2006, p.11.
- [3.7] R. L. Mott, *Applied fluid mechanics*, 6th ed. Upper Saddle River. Pearson Education Inc., 2006, p.228, 231, 233, 235, 237.
- [3.8] Colebrook-White Equation. (2010, October 25). *Solve Colebrook-White equation* [Online]. Available: <http://www.colebrookequation.com/>
- [3.9] M. A. Plint & L. Boswirth, *Fluid mechanics: A laboratory course*, London. Charles Griffin & Company Ltd., 1978, p55–59.
- [3.10] Chemical Professionals. (2010, June 19). *Type of Valves* [Online]. Available: http://profmaster.blogspot.com/2008_10_01_archive.html
- [3.11] R.D. Zucker, *Gas Dynamics*, 2nd ed. Hoboken. John Wiley & Sons, 2002, p. 6, 88, 89.

- [3.12] PHOENIX Engineering. (2010, September 25). *Pumping accessories* [Online]. <http://www.phoenixeng.com.my/Pumps/accessories.htm>
- [3.13] Naggama. (2010, June 19). *High performance butterfly valves* [Online]. Available: http://naggama.co.kr/main/china/china_itemView.php?no=387919
- [3.14] The Energy Research Institute. (2010, June 19). *How to save energy and money in compressed air systems, p31* [Online]. Available: <http://www.3e.uct.ac.za/downloads/compressedair.pdf>
- [3.15] HVAC International. Real-time Energy Management (REMS) compressor manager (CM), Silverlakes Office Park nr. 2, Von Bachstrohm Boulevard, Pretoria.
- [3.16] Minerals and Mining Policy of South Africa. (2010, September 26). *Green paper for public discussion, Sec. 3.5.1.* [Online]. Available: <http://www.info.gov.za/greenpapers/1998/green2~1.htm#chap3>
- [3.17] Compressed Air Challenge. (2010, September 25). *Compressed air system leaks* [Online]. Available: <http://www.compressedairchallenge.org/library/factsheets/factsheet07.pdf>
- [3.18] J.N. Da La Vergne, *Hard rock miner's handbook*, 3rd ed. Ontario. McIntosh Engineering, 2003, p. 179.
- [3.19] MOXA. (2010, September 25). *Remote I/O* [Online]. Available: http://www.moxa.com/product/remote_io.htm
- [3.20] Siemens. (2010, October 2). *Simatic ET 200S* [Online]. Available: <http://www.automation.siemens.com/mcms/distributed-io/en/ip20-systems/et200s/Pages/Default.aspx>

- [3.21] J.J. du Toit, "Conversion of Eimco 26b pneumatic loader to electro-hydraulic control," *Association of Mine Resident Engineers of South Africa*. P O Box 61709, Marshalltown, 2107, Fifth Floor, Chamber of Mines Building, 5 Hollard Street, Johannesburg, 2000, South Africa.
- [3.22] D. Mills, *Pneumatic conveying design guide*, 2nd ed. Burlington. Elsevier Butterworth-Heinemann, 2004, p.250.



VERIFICATION OF THE COST- AND TIME- EFFICIENT CONTROL STRATEGIES

Chapter 4

Verification of the cost- and time-efficient control strategies implemented on actual compressed-air networks at mines.

4 CHAPTER 4: VERIFICATION OF THE COST- AND TIME-EFFICIENT CONTROL STRATEGIES

4.1 Introduction

To evaluate the proposed cost- and time-efficient methods discussed in Chapter 3, four case studies have been conducted from which results were obtained. In all four cases, the proposed projects had limited budgets. This created the opportunity to implement and evaluate the discussed methods.

To calculate the payback periods of these case studies an average value of R0.40/kWh was used. This is the estimated average cost per kilowatt-hour (kWh) for these mines and it takes into consideration all the cost charges as per Eskom Megaflex billing [4.1].

Due to confidentiality agreements, the mines' names will not be revealed. The individual mines will be referred to as Mine A, Mine B, Mine C and Mine D respectively.

4.2 Mine A: Surface infrastructure with multiple compressor houses

The layout at Mine A comprises two production shafts and a gold plant. Compressed air is supplied to these air consumers by the compressors installed at the compressor house situated at One Shaft (1#).

The air reticulation of Mine A is shown in Figure 22. Compressed air is supplied to 1# by two 300 mm parallel air lines. While Three Shaft (3#) has its own compressor house, additional compressed air is also supplied via a single 600 mm line from 1#. This air line starts off as two 300 mm air lines that combine into one 600 mm air line approximately 100 m from the compressor house. The length of

the surface air line feeding 3# from 1# is approximately 3000 m from the compressor house to the shaft entry.

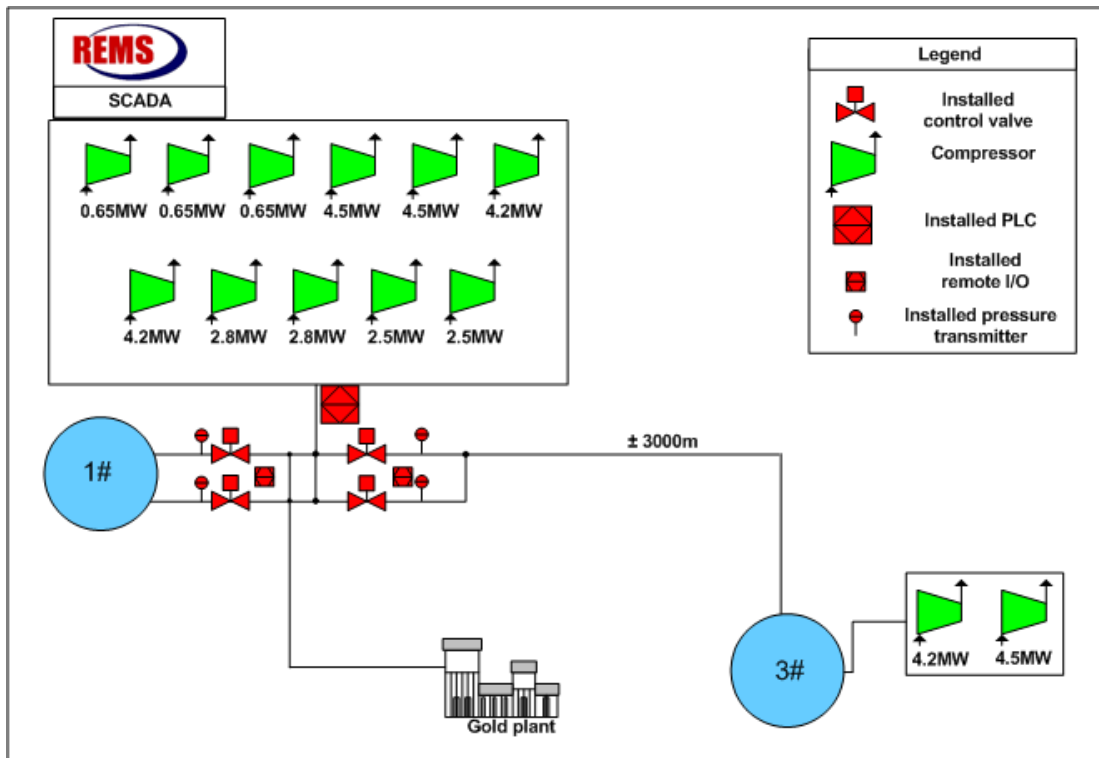

Figure 22: Mine A air reticulation layout (not to scale)

The proposed target for this project was to reduce the demand for electricity by an average of 7.56 MW during the Eskom evening peak period. To achieve this saving, the following infrastructure and methods, as discussed in Chapter 3 were implemented:

Installed infrastructure:

The implemented infrastructure for this project is listed in Table 12.

Table 12: Implemented instrumentation at Mine A

| Instrument | Application/purpose |
|----------------------------------|--|
| High performance butterfly valve | These valves were installed in the air lines feeding compressed air to the shafts. The purpose of these valves was to control the pressure supplied to 1# and volume airflow to 3#. |
| PLC | The PLC is the control interface between the remote communication modules and the SCADA. |
| ET200 remote I/O | A remote communication module connecting the field instruments to the PLC. The remote I/O has no control functionality. |
| Pressure transmitter | Installed downstream from the control valves. This instrument measures the total pressure of the compressed air and returns a milli-ampere signal relevant to the measured pressure. The PLC is calibrated to convert the milli-ampere signal into a kilopascal value that represents the measured pressure. |
| SCADA | Central control node. All field instruments can be viewed and controlled from this node. |
| REMS CM | The real-time energy management system that interprets the system parameters and informs the compressor attendant on the actions needed to be taken to save energy. |

Four pressure-control valves were installed in the 300 mm main air lines leading to 1# and 3#. For this purpose, high performance butterfly valves were selected because they are the most cost-efficient valves when taking into consideration affordability and durability.

One PLC was installed close to the compressor house so that all the field instruments could be connected to it through the ET200 remote I/O. The four valves and corresponding pressure transmitters at each site were connected to the PLC through the remote I/O devices. Remote I/Os were installed instead of PLCs at all the locations where field instruments were installed. This was done because installing remote I/Os at these locations were more cost effective when compared to the cost of installing PLCs.

Field instruments cannot be connected directly to the communication network. For this reason, the ET200 remote I/Os were used to allow the PLC to communicate with all the field instruments through the communication network. The control algorithm for the control valves and the conversion algorithm for pressure transmitters were loaded on the PLC.

The location of the control valves was purposely chosen away from the shaft and close to existing power and communication networks. This method allowed for cost savings (by not having to purchase extra cables and cable racking) and time savings (by not having to implement the hardware). Furthermore, work on the valve installations could take place uninterrupted without the limitations or restrictions that may result from the mine's production schedules.

By installing the valves close to the compressor house, the optimal saving on the line friction pressure losses were obtained. The pressure losses, resulting from line friction, are a function of the system pressure. Thus, the pressure losses resulting from line friction will decrease as the system pressure decreases [4.2].

The two valves controlling the pressure supplied to 1# were installed in the delivery line downstream from the gold plant, relative to the compressor house. This allowed the gold plant to receive the constant high pressure it required throughout the day uninfluenced by the control valves.

REMS CM was installed and connected to the SCADA. REMS CM monitored and controlled all the system parameters through the SCADA since all these devices were connected to the SCADA. The compressor attendant was notified by the REMS CM software when to stop-and-start compressors.

The control instructions displayed to the compressor attendant by REMS CM, were calculated using the system parameters and the predetermined pressure set point schedule. The valves' pressure set points were also predetermined and loaded in the REMS CM software, which allowed the software to control the valves accordingly.

Control strategy:

During the Eskom evening peak period there was no production taking place at either one of the two shafts. This implied that the shafts required a lower pressure and less airflow during that period. The only equipment that required compressed air during the Eskom evening peak was the pneumatic ore loaders and the refuge bays.

The normal pressure set point for this air ring was 420 kPa, regardless of the time of day. To achieve the Eskom evening peak saving, the pressure set point of the control valves would be set at 380 kPa. The equipment with the highest minimum set point determined the minimum pressure set point for the shaft. In this case the minimum set point was determined by the pneumatic loaders that had to be used during the Eskom evening peak periods.

The air pressure upstream increased as a result of the pressure control enforced by the control valves. Normally, this would cause the control system to reduce the compressor guide vane opening, which would reduce the mass-flow rate resulting in reduced electricity demand. However, the compressors installed at Mine A are old and have no guide vane control. For that reason the compressors could only supply compressed air at a fixed capacity.

The reduction in airflow to the demand side, resulting from the control enforced by the control valves, reduced the demand for air supply. To match the air supply to the demand without the use of guide vanes, three of the eight compressors were stopped during the Eskom evening peak period.

The pressure upstream remained at 420 kPa as required by the gold plant. However, the gold plant is a high-pressure, low-airflow consumer that implies little line friction pressure losses in the high-pressure air line due to the low air velocity. Caution should be given to the air leaks on this part of the air ring, since the amount of compressed air lost through air leaks are proportional to the air pressure.

No pressure reduction was required on the air line leading to 3# due to the long distance the air had to travel through the air line to reach the shaft. The required pressure reduction occurred as a result of pressure losses from line friction. The two control valves were installed in that air line only to maintain a specified airflow to the shaft.

Should the demand to 3# have a sudden increase, as in the event of a ruptured air line, the 420 kPa on the high-pressure side will be maintained and so have no effect on the air supplied to 1#. This will be possible because the two valves control the airflow flowing through them, and not the pressure difference across them.

Using the formulas in Section 3.5 the estimated pressure drop across the air line was calculated. For the purpose of the calculations, the system delivery pressure was accepted to be 420 kPa and the air temperature 303.15 K. The pressure drop across the air line with an estimated length of 3000 m was calculated to be 33.4 kPa. The detailed calculations are shown in the Appendix.

Figure 23 illustrates an average 24-hour profile of pressure data measured over the period of one month. The pressure difference between 3# and the compressor house can clearly be seen in this graph. From the measured data it was found that the average pressure drop across the air line is 40.4 kPa. This is a 17% difference when compared to the calculated value. The most probable reason for the difference in results is the increased line friction resulting from the effects of rust and corrosion in the old pipes.

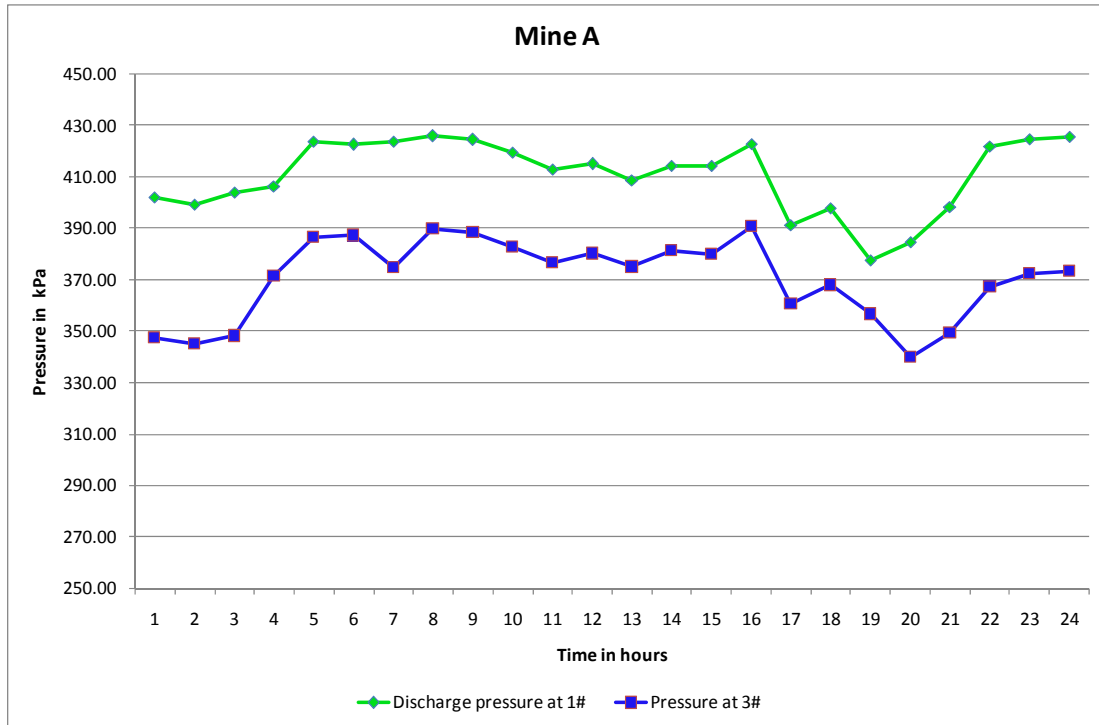

Figure 23: Pressure drop resulting from line losses at Mine A

Resulting savings:

In some cases the introduction of an energy saving project causes the mine employees to be more aware of energy savings than usual. This often results in air leaks being repaired that would normally have been left unchecked. These actions can cause the entire system to become more energy efficient.

This was the case with Mine A. The energy efficiency component shown in Figure 24 is a result of air leaks and open-ended compressed-air pipes that were repaired. These actions were taken after the baseline was measured and the contracted ESCo proposed the project to the mine.

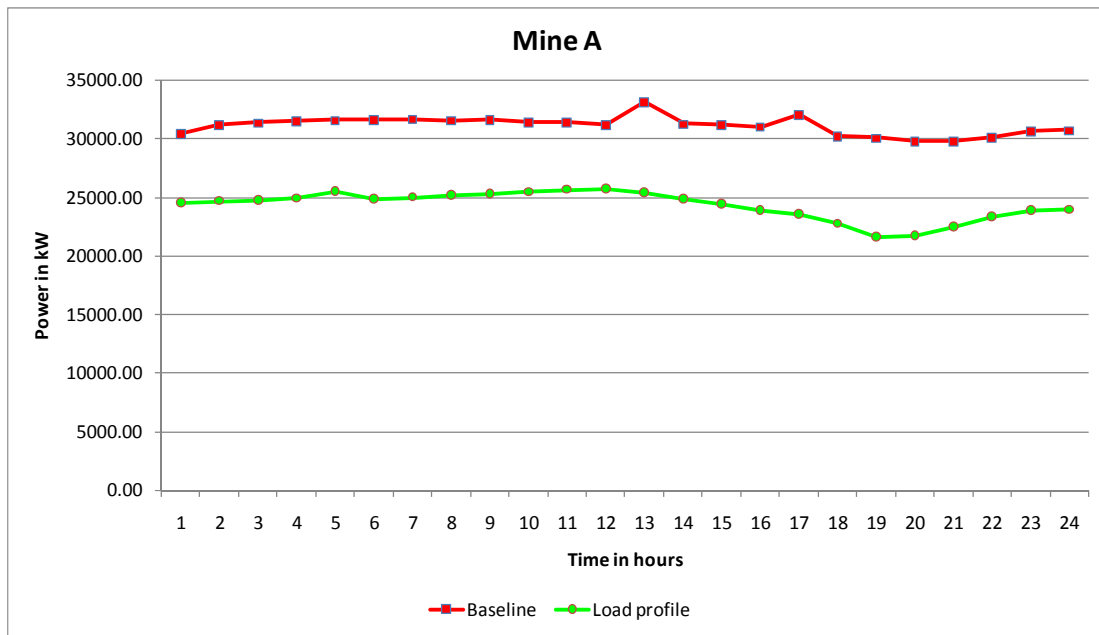

Figure 24: Mine A load profile vs baseline

To prove the sustainability of the project Eskom required a three-month performance assessment period to be completed. During this period the average electricity demand was reduced by 8.26 MW during the Eskom evening periods, which exceeded the target saving of 7.56 MW by 0.7 MW. The reduction in electricity during the evening peak resulted in an average evening peak period saving of R132,160 per month. The savings were calculated using the 2009/2010 Eskom Megaflex tariffs. The achieved saving was validated by an external independent auditor.

Figure 24 shows the baseline of the project and the actual load reduction as a result of the project. The total infrastructure cost for Mine A was R2,700,041. Based on the average R0.40 per kWh, the accumulated saving resulting from the demand reduction in the Eskom peak period would reimburse the project's cost in an estimated time of 20 months.

However, the financial savings would not only be realised by the peak period reduction in electricity but also from the reduced 24-hour energy load. The energy saving that resulted from the 24-hour load reduction was an average of 162.96 MWh per day. This efficiency saving resulted in a financial saving of

R1.3 million per month. With this saving the estimated project payback period was calculated to be only two months. Figure 25 is a graphical representation of the payback periods for Mine A versus the infrastructure cost of the project.

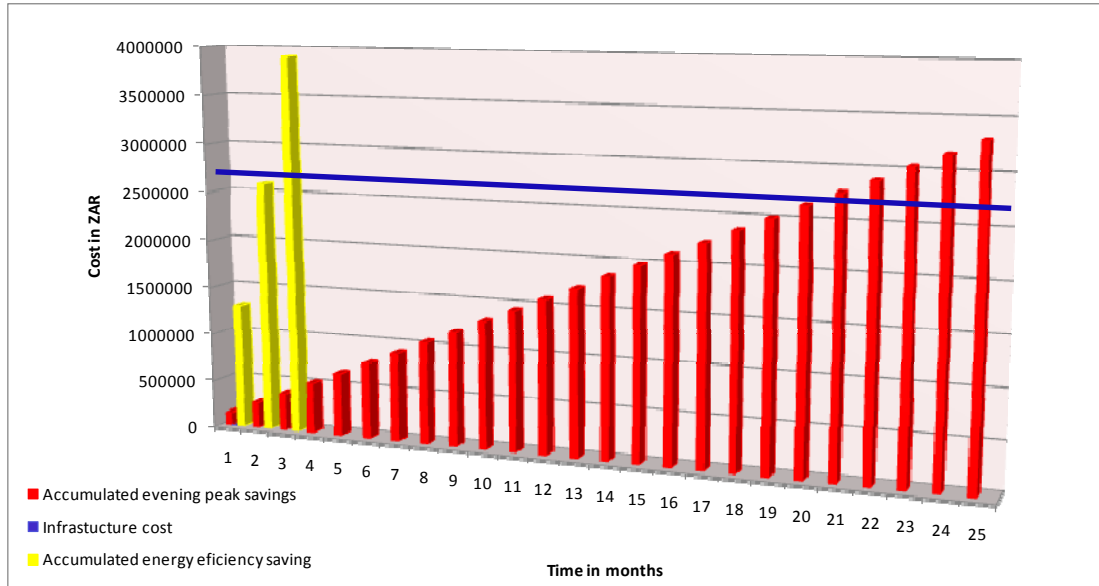

Figure 25: Estimated payback period for Mine A

The total implementation period of this project was eight months. This excluded the three-month performance assessment period.

4.3 Mine B: Surface infrastructure with multiple compressor houses

Figure 26 illustrates the air reticulation layout of Mine B. The two operational compressors installed at the Seven Shaft (7#) compressor house supplies compressed air to 7# through two parallel air supply lines.

A single compressor is installed at Four Shaft (4#), but it does not have the capacity to sustain the air pressure required by 4#. An underground air line connecting 4# and 7# on 23 Level is used to deliver air from 7# to supplement the pressure required by 4#.

The gold plant at 7# only requires high pressure at a low flow rate. The compressed air consumed by the gold plant is mainly used for pneumatic actuators and agitation that require a constant high pressure at a low airflow rate.

The target for this project was to reduce the electricity demand by 3.78 MW during the Eskom evening peak period.

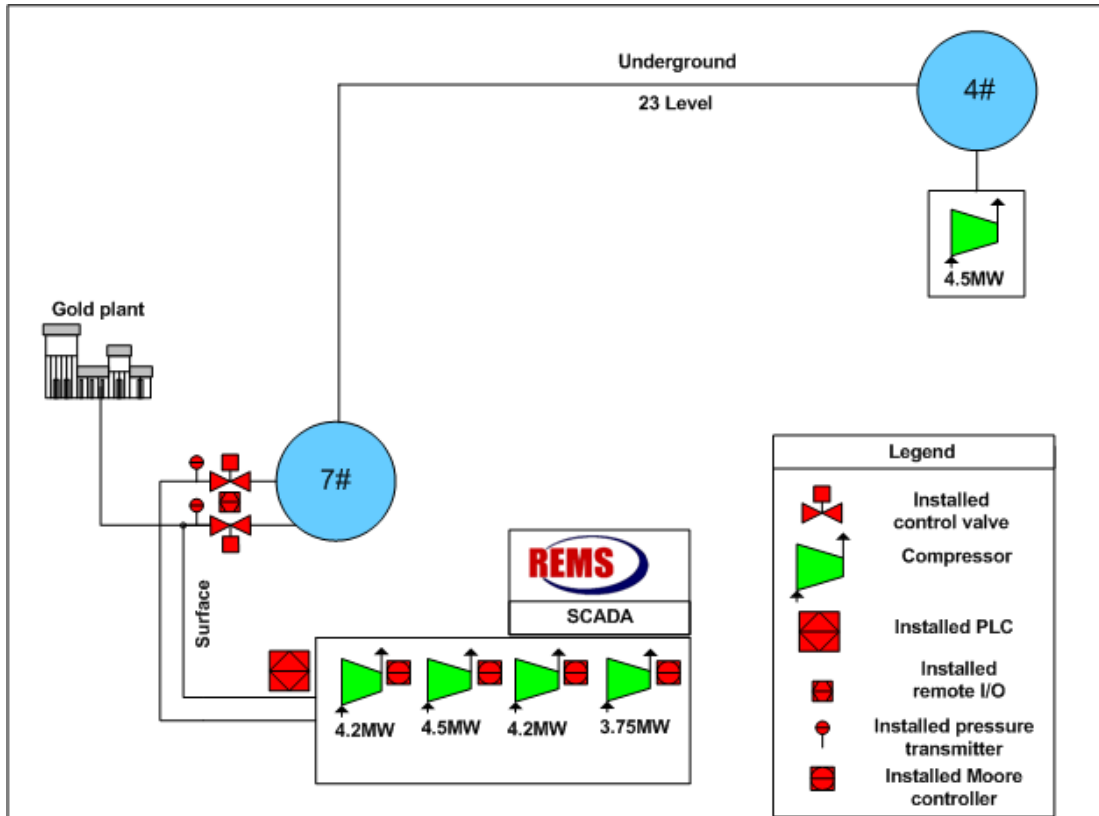

Figure 26: Air reticulation layout of Mine B (not to scale)

To achieve this saving the following infrastructure and methods (discussed in Chapter 3) were implemented:

Installed infrastructure:

The implemented infrastructure for this project is listed in Table 13.

Table 13: Implemented instrumentation at Mine B

| Instrument | Application/purpose |
|----------------------------------|---|
| High performance butterfly valve | Installed in the air lines feeding compressed air to the shaft. The purpose of these valves is to control the pressure supplied to the shaft. |
| PLC | The control interface between the communication modules and the SCADA. |
| ET200 remote I/O | A remote communication module connecting the field instruments to the PLC through the communication network. The remote I/O module has no control functionality. |
| Pressure transmitter | Installed downstream from the control valves. This instrument measures the total compressed-air pressure and returns a milli-ampere signal relevant to the measured pressure. The PLC is calibrated to convert the milli-ampere signal into a kPa value representing the measured pressure. |
| SCADA | Central control node. All field instruments can be viewed and controlled from this node. |
| Moore controller | A Moore controller controls the guide vanes and blow-off valve of a compressor. |
| REMS CM | The real-time energy management system that interprets the system parameters and informs the compressor attendant what actions need to be taken to save energy. |

Two pressure-control valves were installed in the main air lines leading to 7#. For this application high performance butterfly valves were selected. These butterfly valves offer the most cost benefits when considering affordability and durability.

One PLC was installed close to the compressor house so that all the field instruments could be connected to it. The two valves and corresponding pressure transmitters were connected to the PLC through the ET200 remote I/O modules. Remote I/Os were installed instead of PLCs at all the locations where field instruments were installed. This was done because installing remote I/Os at these locations were more cost effective when compared to the cost of installing PLCs.

Field instruments cannot be connected directly to the communication network. For that reason, the ET200 remote I/O modules were used to allow the PLC to communicate with all the field instruments through the communication network. The control algorithm for the control valves and the conversion algorithm for pressure transmitters were all loaded on the PLC database.

The compressors guide vanes were controlled by the Moore controllers installed at each of the compressors. These controllers were connected to the PLC through the use of an existing Ethernet network. The control of each compressor's guide vane was done by its corresponding Moore controller. The control set point used by the respective Moore controllers was received from the PLC. The correct set point value was sent to the PLC from the REMS CM platform.

The location of the valves was purposely chosen away from the shaft and close to existing power and communication networks. This method allowed for cost savings (through not having to purchase extra cables and cable racking) and time savings (by not having to implement the hardware). Furthermore, work on the valve installations could take place uninterrupted without the limitations or restrictions that may result from the mine's production schedules.

By installing the valves close to the compressor house, the optimal saving on the line friction pressure losses were obtained. The pressure losses, resulting from line friction, are a function of the system pressure. Thus, the pressure losses resulting from line friction will decrease as the system pressure decreases [4.2].

The two valves controlling the pressure supplied to 7# were installed in the delivery line downstream from the gold plant, relative to the compressor house. This allowed the gold plant to receive the constant high pressure it required throughout the day, uninfluenced by the control valves.

To control the discharge pressure set points of the compressors, Moore controllers were installed on the compressors. These upgrades would allow a compressor to maintain the set point sent to it from the PLC. The SCADA is used to

communicate with the PLC while REMS CM controls the commands that is sent to the SCADA for execution.

Since this was a small project (measured by the amount of instrumentation implemented) when compared to other projects of this nature, the most cost-beneficial SCADA licence could be purchased. The smallest SCADA licence is a licence for 500 tags. This licence was adequate to manage the installed instrumentation.

REMS CM was installed to monitor all the system parameters. The Compressor Manager (CM) software can write pressure set points to the controller units and PLC through the SCADA. However, since the compressors could not be fully automated due to cost, REMS CM still needed to notify the compressor attendant when to stop-and-start a compressor. The valves' pressure set points were also predetermined and loaded in the REMS CM software, which allowed the software to control the valves accordingly.

Control strategy:

The gold plant and shaft required 500 kPa throughout the day although the demand in airflow varied during the day. No production took place during the Eskom evening peak period, which implied a reduction in airflow during this period.

To achieve the proposed savings without lowering the pressure, the volume airflow needed to be controlled. The volume airflow required during the Eskom evening peak period resulted in one of the two control valves to be closed. The second valve was used to control the volume airflow to the shaft.

The pressure upstream increased as a result of the pressure control enforced by the control valves. This caused the REMS software to reduce the compressor guide vane opening, which resulted in the compressors consuming less electricity.

Resulting savings:

In some cases the introduction of an energy saving project causes the mine employees to be more aware of energy savings than usual. This often results in air leaks being fixed that would normally have been left unchecked. These actions can cause the entire system to become more energy efficient.

This was the case with Mine B. The energy efficiency component shown in Figure 27 is a result of air leaks and open-ended compressed-air pipes that were fixed. These actions were taken after the baseline was measured and the contracted ESCo proposed the project to the mine.

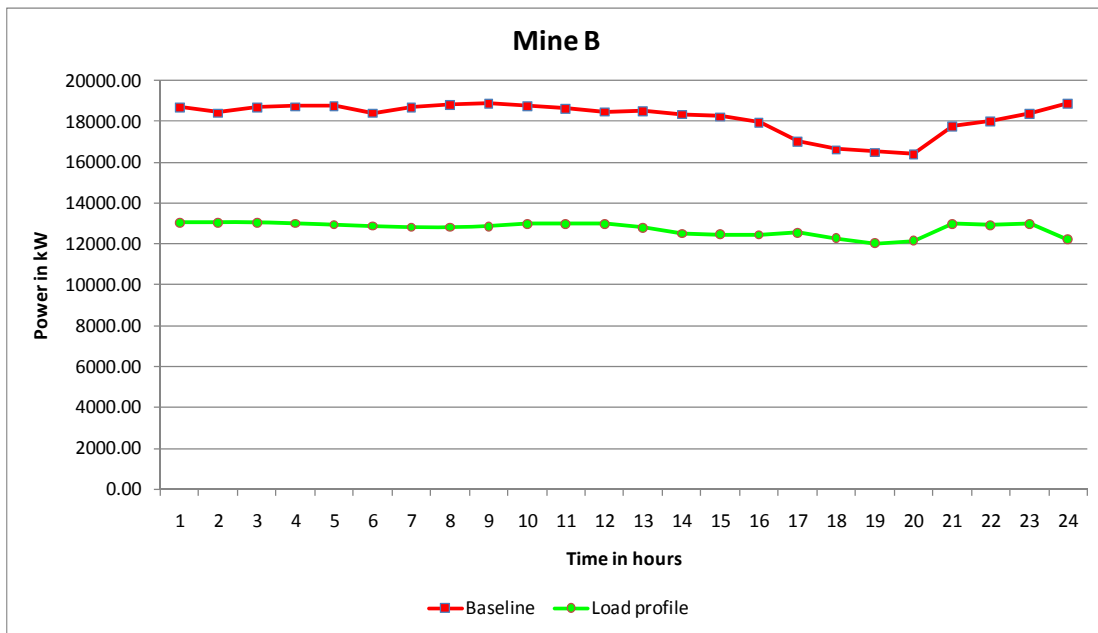

Figure 27: Mine B load profile vs baseline

To prove the sustainability of the project Eskom required a three-month performance assessment period to be completed. During this period the average electricity demand in the Eskom evening peak was reduced by 4.32 MW. This saving exceeded the target saving of 3.87 MW by 0.45 MW.

The reduction in energy in the Eskom evening peak period resulted in an average financial saving of R69,136 per month. The savings were calculated using the

2009/2010 Eskom Megaflex tariffs. The achieved saving was validated by an external independent auditor.

Figure 27 shows the baseline of the project and the actual load reduction as a result of the project. The total infrastructure cost for Mine B was R1,094,914. Based on the average of R0.40 per kWh, the estimated saving resulting from the energy reduction in the Eskom peak period would reimburse the project in 15 months.

However, the financial savings would not only be realised by the peak period reduction in electricity, but also from the reduced 24-hour energy load. The saving resulting from the 24-hour load reduction is an average of 131.28 MWh per day.

This efficiency saving resulted in an estimated financial saving of R1.05 million per month. This saving implied a project payback period of only one month. Figure 28 is a graphical representation of the payback periods for Mine B versus the infrastructure cost of the project.

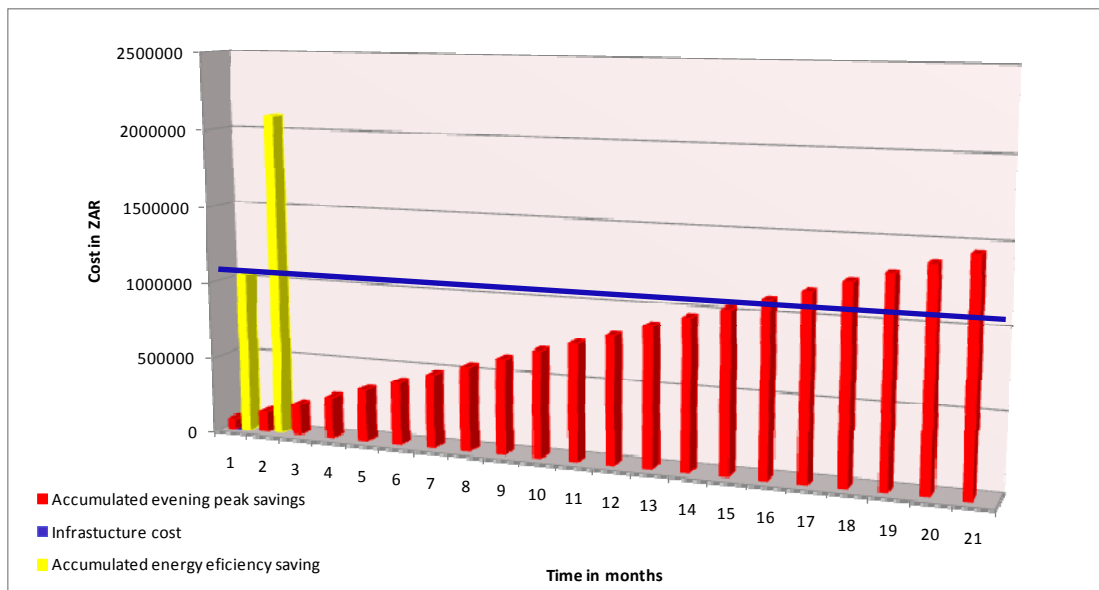

Figure 28: Estimated payback period for Mine B

The total implementation time of this project was eight months. This excludes the three-month performance assessment period.

4.4 Mine C: Surface and underground infrastructure with a single compressor house

Of the two shafts at this mine, only One Shaft (1#) is a production shaft. Two Shaft (2#) is an old shaft that is currently only being used to lower and hoist personnel in and out of the mine. This is an old mine that does not have the modern infrastructure such as communication networks, SCADA systems and automated compressor networks.

Compressed air is supplied to 1# and the gold plant from the four compressors installed at the compressor house located at 1#. The supply pressure required during the production period is 550 kPa. Figure 29 depicts the surface air reticulation and general layout of Mine C.

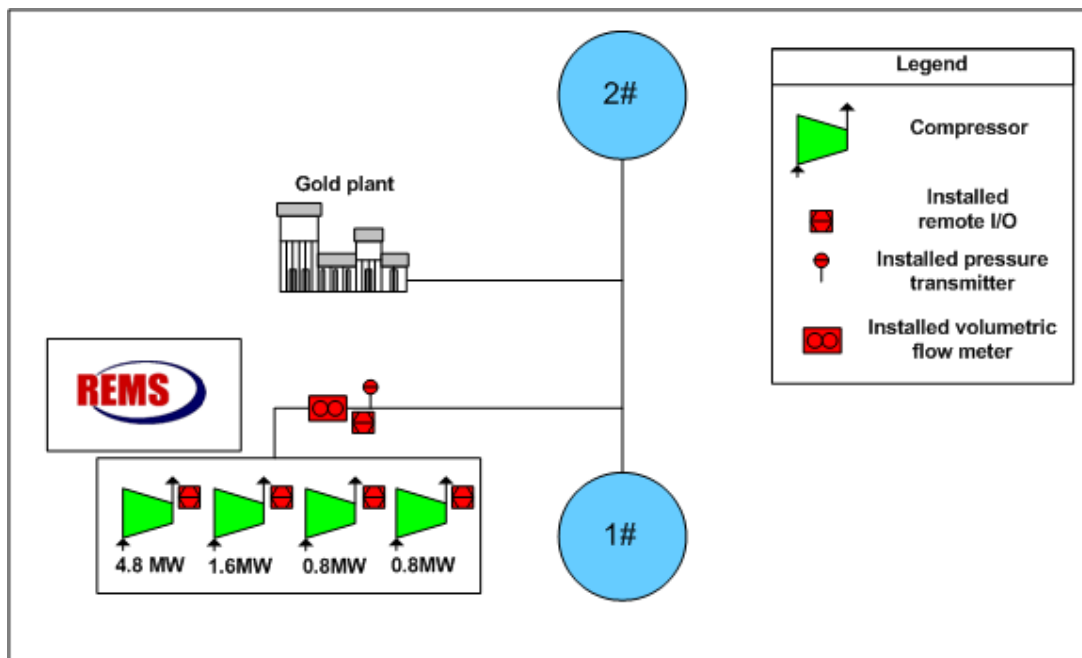

Figure 29: The air reticulation layout of Mine C (not to scale)

The target for this project was to reduce the electricity demand by 2.5 MW during the Eskom evening peak period. To achieve this saving, the following infrastructure and methods (discussed in Chapter 3) were implemented:

Installed infrastructure:

The implemented infrastructure for this project is listed in Table 14.

Table 14: Implemented instrumentation at Mine C

| Instrument | Application/purpose |
|---------------------------|--|
| Butterfly valve | Isolating valve used to isolate compressed air. |
| Timer-based controller | Used to open and close the butterfly valves during the Eskom evening peak periods. |
| Moxa communication module | Communication module that allows the control node to view the status of the instrumentation connected to the unit. This module is an alternative for a PLC but with limited controllability. |
| Pressure transmitter | Installed at the discharge side of the compressors. This instrument measures the total compressed-air pressure and returns a milli-ampere signal representing the measured pressure. The Moxa communication module is calibrated to convert the milli-ampere signal into a kilopascal value representing the measured pressure. |
| Flow meter | A volumetric-flow meter was installed at the discharge side of the compressor house to measure the volume airflow supplied by the compressors. This instrument measures the air velocity and returns a milli-ampere signal representing to the measured airflow velocity. The Moxa communication module was calibrated to convert the milli-ampere signal into a m ³ /s value representing the measured volumetric flow rate. |
| REMS CM | The real-time energy management system that interprets the system parameters and informs the compressor attendant what actions need to be taken to save energy. |

Four pressure transmitters (one on each compressor) were installed to measure the discharge pressure of the compressors. These pressure transmitters could be connected to the existing communication network through the use of a Moxa communication module. These communication modules were installed as an alternative to PLCs since they are more cost efficient. The Moxa units enable the REMS CM software to monitor the compressors discharge pressure.

A single volumetric-flow meter was installed on the discharge side of the compressor house and connected to the REMS CM software using a Moxa communication module. This was more cost efficient when compared to installing a mass-flow meter for reasons explained in Chapter 3. The volumetric-flow meter allowed the REMS CM software to monitor the total air supplied to the system.

Automation of the compressors would have been the preferred solution to control the compressors; but it is an expensive method and the cost exceeded the budget for the project. The REMS CM software monitors the system conditions and notifies the compressor attendant when to stop-and-start the compressors. The control parameters in REMS CM software are based on the preloaded control schedule that takes TOD and system pressure into consideration.

To sustain the system pressure during the Eskom evening peak period, two butterfly valves were installed underground on the air lines leading into 1#'s two production levels. These two valves were closed during the Eskom evening peak to isolate the air supplied to those sections. The layout of the two levels were extensive and integrated. Finding air leaks and open-ended air lines were extremely difficult. By isolating the supply to those levels all the air leaks and open-ended air lines in those levels were isolated.

Since the mine has no underground communication network, a communication network would have had to be installed to those sections to control the two isolating valves. To install optical fibre down the shaft, along with all the infrastructure that is required to communicate with the two butterfly valves, is extremely expensive and the cost exceeded the budget of the project.

Installing optical fibre down the shaft would also have been an extremely time-consuming exercise. The installation would have had to wait for an occasion when it would not affect the production schedule and the shaft would be accessible to install the cable.

The cost-effective alternative was to install a timer-based controller to control the actuators on the valves. The valves could automatically be closed to isolate the airflow to the underground levels between 18h00 and 20h00.

Control strategy:

To achieve the target saving a compressor control strategy was implemented where the 4.8 MW compressor was stopped during the Eskom evening peak. This was possible because the air demand was minimised when the two installed underground valves isolated the production levels from the rest of the compressed-air network.

Preliminary studies indicated that the smaller 0.8 MW compressor would be sufficient to supply compressed air to the rest of the compressed-air network during the Eskom peak period. If, during this period, the demand increased beyond the supply capacity of the 0.8 MW compressor the second 0.8 MW compressor could be brought online to help sustain the required demand for compressed air.

Resulting savings:

To prove the sustainability of the project Eskom required a three-month performance assessment period to be completed. During this period the average demand for electricity was reduced by 2.1 MW. That is an average evening peak saving of R33,600 per month on the 2009/2010 Eskom Megaflex tariffs. The achieved saving was validated by an external independent auditor.

The achieved saving was 0.4 MW less than the proposed 2.5 MW target. The reason the savings target was not achieved was due to the combination of a poor

maintenance schedule and increasing air leaks. The one 0.8 MW compressor had to be serviced during the performance assessment period and due to bad planning, it could not be completed before the end of the performance assessment period.

The increase in air leaks, due to poor maintenance, meant the one 0.8 MW compressor could not supply a sufficient amount of compressed air during the Eskom evening peak. Because the second 0.8 MW compressor was out of commission during this time, the compressor control strategy had to be adjusted so that the 1.65 MW compressor were used as a baseload supply instead of the 0.8 MW compressor. The situation deteriorated to the point where the 0.8 MW compressor had to be brought online with the 1.65 MW compressor to sustain the demand for compressed air in the Eskom peak period.

Figure 30 depicts the baseline of the project and the actual load reduction as a result of the project.

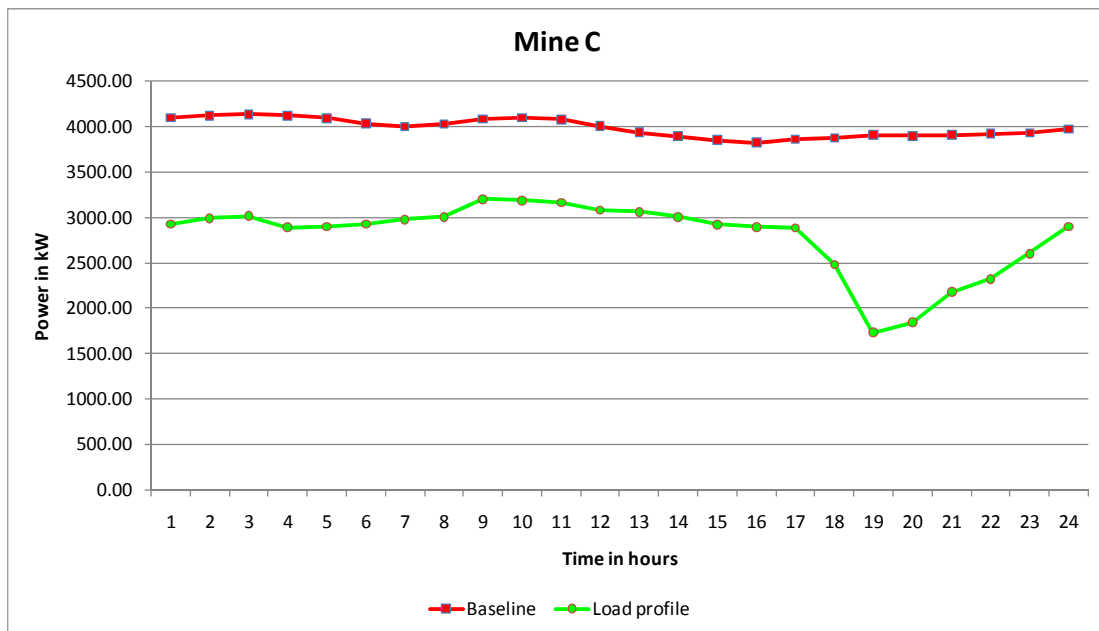

Figure 30: Mine C load profile vs baseline

Although the proposed evening peak saving could not be achieved, the general efficiency of the system was improved, which resulted in a 28.8 MWh saving per

day. This energy efficiency saving resulted in an average R230,400 financial saving per month based on the 2009/2010 Eskom Megaflex tariffs.

The total infrastructure cost of the project was R690,605. Based on the savings generated from the Eskom evening peak load reduction the project payback period was estimated to be 20 months. However, if the total saving resulting from the energy efficiency is brought into calculation, the estimated project payback period is only three months. Figure 31 is a graphical representation of these payback periods for Mine C versus the initial project cost.

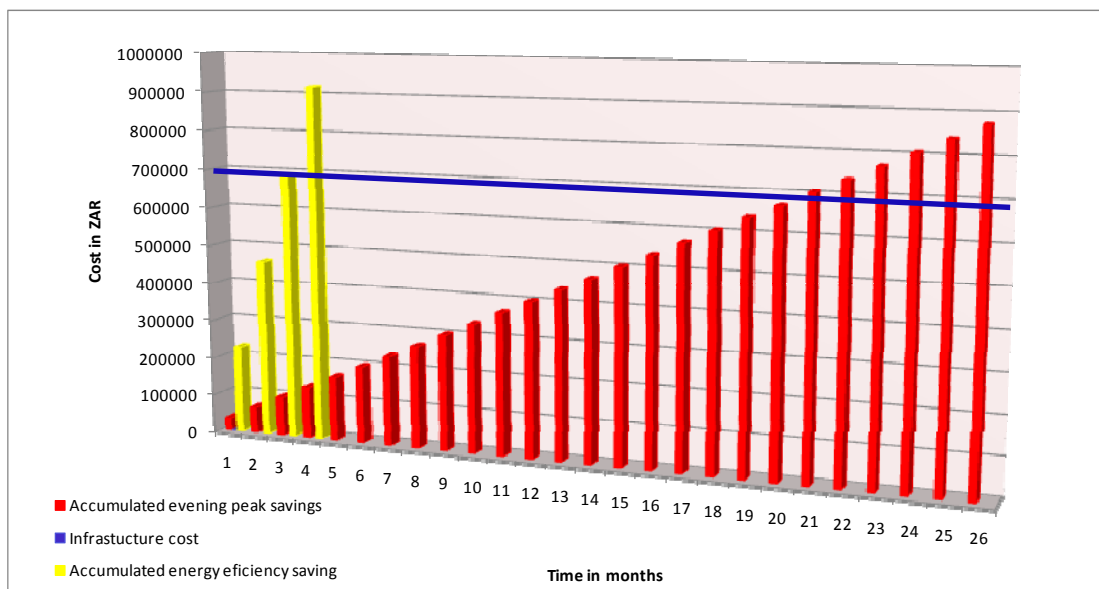

Figure 31: Estimated payback period for Mine C

The total implementation time of this project was eight months. This excludes the three-month performance assessment period.

4.5 Mine D: Surface and underground infrastructure with multiple compressor houses

Mine D has four shafts of which two have been decommissioned. However, the compressors installed at the decommissioned shafts are still operational and are used to supply the baseload compressed air to the air ring.

Three Shaft (3#) is a hydro shaft, which means the shaft uses high-pressure water for drilling instead of compressed air. Four Shaft (4#) is a new production shaft that uses compressed air only for drilling and hoisting. The auxiliary equipment makes use of electrical actuators or hydropower pistons.

The only other air consumer is the gold plant, which also uses compressed air from the air ring. The two decommissioned shafts are completely isolated from the air ring by the two isolating valves installed close to these shafts. Figure 32 depicts the surface air reticulation and the mine layout.

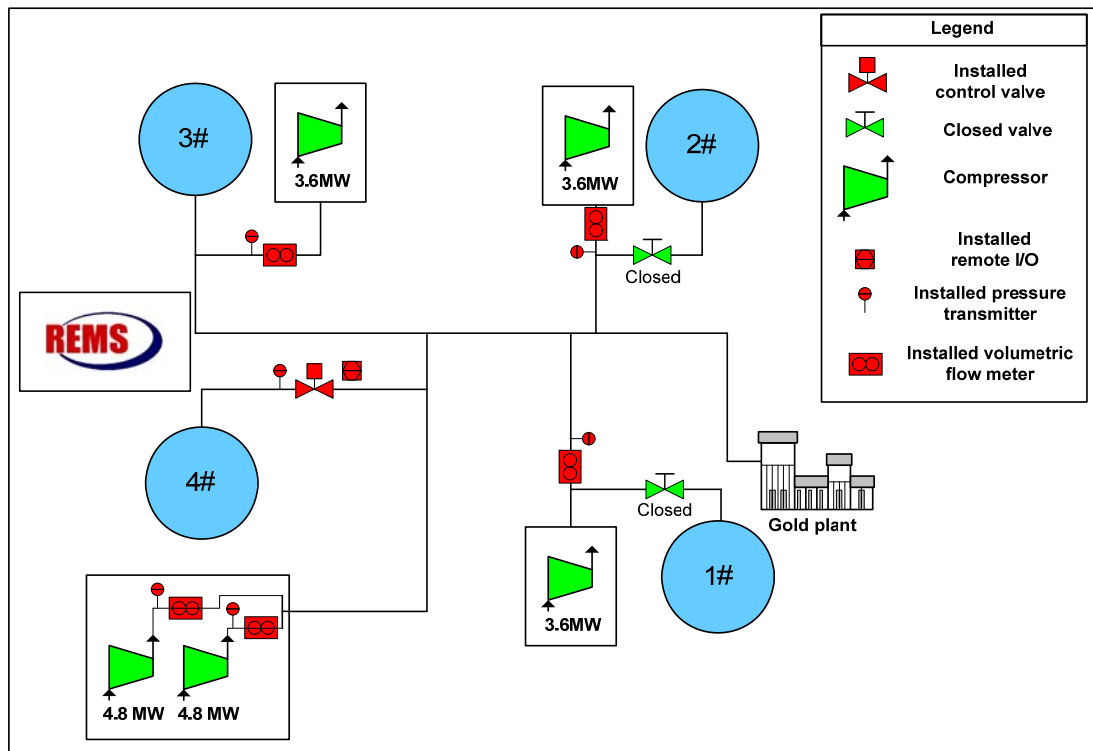

Figure 32: The air reticulation layout of Mine D (not to scale)

The proposed target for this project was to reduce the electricity demand by 3.11 MW during the Eskom evening peak period. To achieve this saving, the following infrastructure and methods (discussed in Chapter 3) were implemented:

Installed infrastructure:

The implemented infrastructure for this project is listed in Table 15.

Table 15: Implemented instrumentation at Mine D

| Instrument | Application/purpose |
|---------------------------|---|
| Butterfly valve | Pressure-control valve installed at 4#. |
| Moxa communication module | Communication module that allows the control node to view the status of the instrumentation connected to the unit. This module is an alternative to the PLC with limited controllability. |
| Pressure transmitter | Installed downstream from the control valve and on the discharge of each compressor. This instrument measures the total compressed-air pressure and returns a milli-ampere signal relevant to the measured pressure. The Moxa communication module is calibrated to convert the milli-ampere signal into a kilopascal value representing the measured pressure. |
| Flow meters | Volumetric-flow meters were installed on each of the compressors to measure the volume airflow supplied by each of the compressors. This instrument measures the air velocity and returns a milli-ampere signal representing the measured airflow velocity. The Moxa communication module is calibrated to convert the milli-ampere signal into a m ³ /s value representing the measured volumetric flow rate. |
| Hydraulic power packs | A system that provides an alternative power source to replace pneumatic pistons. The pneumatic system is converted into a hydraulic closed-loop system. This implies that the hydraulic system is self-contained and completely independent from the pneumatic system and its pressure. |

| Instrument | Application/purpose |
|------------|---|
| REMS CM | The real-time energy management system that interprets the system parameters and informs the compressor attendant what actions need to be taken to save energy. |

Compressed air in 4# is only consumed by pneumatic drills (used during the drilling shift) and pneumatic pistons on the loaders (used during hoisting). The drilling shift falls outside the Eskom evening peak period, which means compressed air is mainly used for hoisting during the evening peak period.

The minimum pressure requirement for 4# is 500 kPa. This means that the only way to reduce the shaft pressure during the Eskom evening peak period would be to convert the pneumatic equipment requiring 500 kPa to a different power source that is not dependant on compressed air.

The solution to this problem was to install hydraulic power packs at each of the loaders and convert the pneumatic pistons to hydraulic pistons. By doing this compressed air is no longer a requirement for the loaders. Figure 33 shows a hydraulic power pack installed at a loader and Figure 34 shows one of the pneumatic pistons of a loader that needed to be converted.



Figure 33: Photo of a hydraulic power pack



Figure 34: Photo of a pneumatic piston on a loader

By installing a single pressure-control valve in the surface air line feeding 4#, the pressure to the shaft could be reduced from the 500 kPa to 120 kPa during the Eskom evening peak. A normal butterfly valve was selected to enable pressure control because it is the most cost-effective alternative. The distant location of the valve, relative to the everyday working areas, did not pose a health risk when considering the noise generated by the valve when pressure control took place.

The Eskom-granted subsidy for the project was mainly used for the installation of the hydraulic power packs. The compressed air supplied to the shaft could not be shut off because compressed air is required to keep the refuge bays positively charged. As shown in Figure 32, a pressure transmitter (monitored by the same Moxa communication unit that controlled the butterfly valve) was installed downstream from the valve to give system pressure feedback to the REMS CM platform. The Moxa communication module was used instead of a PLC to free up funds needed for the installation of the hydraulic power packs.

The REMS CM platform software was installed at the mine's control room from where all system parameters could be viewed. The cost of improving the

compressor controls to automatically stop-and-start exceeded the budget for the project.

Instead, a volumetric-flow meter and pressure transmitter was installed on the discharge side of each compressor, to give operational status feedback of each compressor to the REMS CM platform. As explained in Chapter 3, installing a volumetric-flow meter in conjunction with a separate pressure transmitter, is more cost efficient than installing a mass-flow meter.

By monitoring the operational status of each compressor, the REMS CM software could notify the compressor operator, which compressors needed to be stopped and started manually to achieve the desired savings. The 4# valves' pressure set points were also preloaded in the REMS CM software and could be controlled from the REMS CM platform.

Control strategy:

A compressor control strategy could be implemented because the 4# air demand could be reduced. The set point of the 4# surface pressure-control valve was set by REMS CM to 120 kPa during the Eskom evening peak.

The reduction in air demand would have allowed one of the 3.6 MW baseload compressors to be stopped during this period. However, due to mechanical restrains resulting from poor maintenance, none of the baseload compressors could be stopped. The only energy reduction possible was to keep the compressors running, but in an off-load status.

This implied the compressor was isolated from the supply ring but kept running. The free-running compressor places very little load on the electric motor driving it. In this case it caused the electric motor to consume approximately 50% less electricity. This method does generate an electricity saving but not enough to reach the proposed target saving.

Resulting savings:

To prove the sustainability of the project, Eskom required a three-month performance assessment period to be completed. During this period, the average demand for electricity was reduced by 3.05 MW. That is an average evening peak saving of R48,480 per month based on the 2009/2010 Eskom Megaflex tariffs. The achieved saving was validated by an external independent auditor.

The project underperformed with 0.8 MW during the Eskom evening peak periods due to compressors that could not be stopped. Figure 35 shows the baseline of the project and the actual load reduction after implementation.

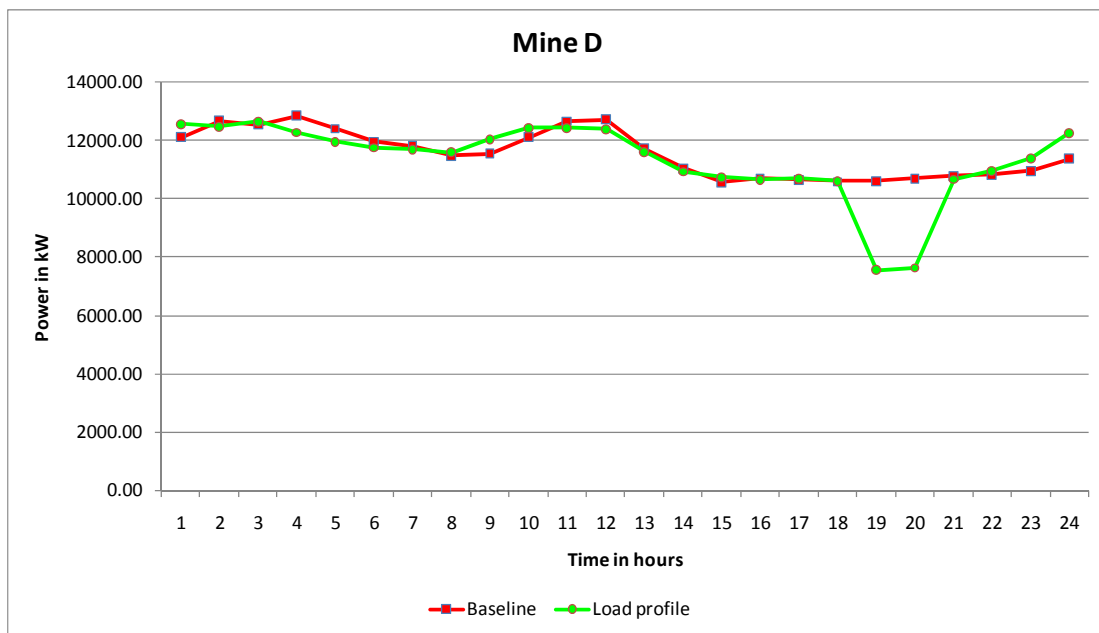

Figure 35: Mine D load profile vs baseline

Along with the evening peak saving there was also an energy efficiency saving of 5.52 MWh per day. However, the load line did exceed the baseline during the whole Eskom morning peak period, which resulted in more energy being used during one of the most expensive time periods.

If the additional energy that was used during the morning peak is taken into calculation, the estimated monthly savings are calculated to be R44,160 per

month, based on the 2009/2010 Eskom Megaflex tariffs. This is R4,320 less than the saving that is realised by the Eskom evening peak reduction saving.

The total infrastructure cost of the project was R1,786,241. If only the savings realised during the evening peak period were taken into account, the estimated payback period for the project was calculated to be 36 months. However, with the additional cost added due to the extra energy used during the expensive morning peak period, the payback period was extended to a period of 40 months. Figure 36 is a graphical representation of the payback periods for Mine D versus the initial project cost.

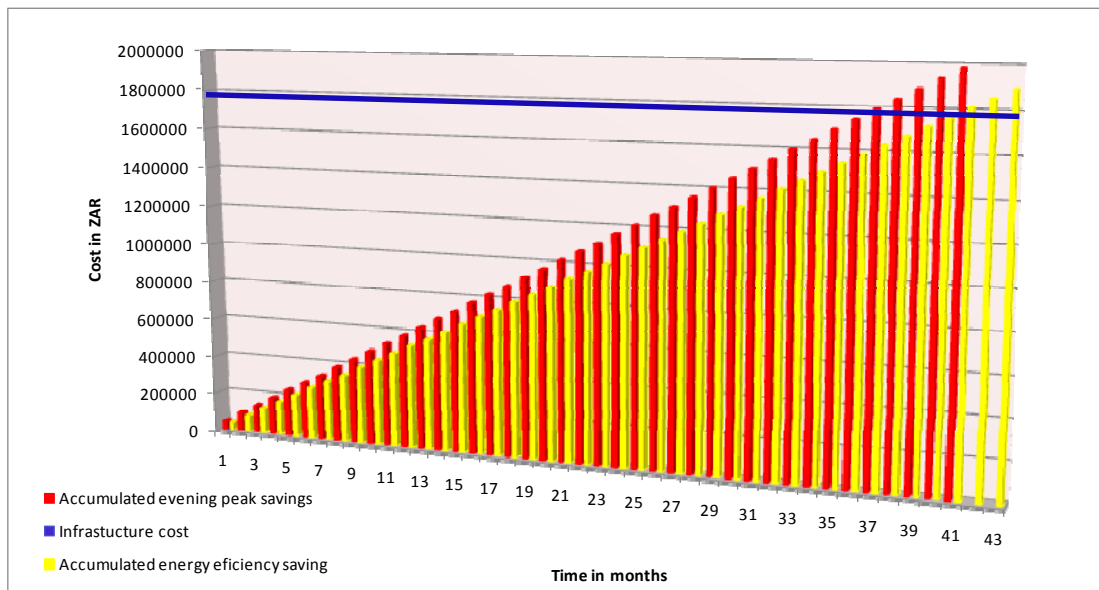

Figure 36: Estimate payback period for mine D

The total implementation time of this project was nine months. This excludes the three-month performance assessment period.

4.6 Conclusion

These projects have shown that it is possible to implement cost- and time-efficient DSM projects on mine compressed-air systems. None of these mines are operating under automatic compressor control and the sustainability of the savings

will be difficult to achieve. A comparison between the case study projects and projects with fully automated compressors will be discussed in Chapter 5.

In comparison to projects that involved full automation of compressors, and installed infrastructure costing almost twice as much as these projects, the DSM projects achieved similar results.

A computer-controlled system's only function is to continuously monitor and control the compressed-air system. During manual operation, the operator is tasked with several responsibilities. It is possible that the operator can make a mistake that can negatively influence the savings. The human error factor in this case is inevitable.

4.7 References

- [4.1] Eskom Tariff book. Eskom, Megawatt Park, Maxwell Drive, Sunninghill, Sandton, South Africa.
- [4.2] Distribution Piping. (2010, October 16). *Compressed air challenge* [Online]. Available: <http://www.compressedairchallenge.org/library/articles/2010-02-CARP.pdf>



RECOMMENDATIONS AND CONCLUSION

Chapter 5: The recommendations for future work on the case study projects as well as their successfulness when compared to successful past projects, are discussed in the chapter. This discussion is the basis on which the conclusion of the study's outcome is made.

5 CHAPTER 5: RECOMMENDATIONS AND CONCLUSION

5.1 Recommendations for further work

The preferred solution that applies to all four of the investigated case studies is to automate the compressors. This will allow for optimal guide vane control; faster stop-and-start of compressors; automatic stop-and-start of compressors; and sustainable savings. However, automating compressors are expensive and it is unlikely to happen at the mines discussed in the case studies.

A second recommendation would be to install small compressors at the gold plants of each mine. In all four cases the gold plants demand a high surface pressure for the pneumatic instrumentation used in the plants. By installing a small compressor that can deliver high pressure at a low flow rate, the plants could be isolated from the existing air network. By excluding the gold plants from the air ring through the use of this method, the surface pressure can be reduced even more during the Eskom peak periods.

Specific recommendations that are applicable to the specific case studies are discussed in the following sections.

5.1.1 Recommendations for Mine A

As mentioned in the case study, the compressors installed at this mine have no guide vane control. By upgrading/repairing the guide vanes on these compressors, the controllability of the compressors can be improved. This will improve the controllability of the compressors and by doing so improve the energy saving resulting from the pressure control.

If the compressors could be automated, the next initiative would be to control air consumption on the demand side. The saving potential and feasibility of such a project is an entire study on its own and thus it is only recommended as a potential improvement.

5.1.2 Recommendations for Mine B

If the compressors are automated to ensure the sustainability of the existing project, the next step would be to implement a project that will focus on the reduction of compressed-air use of the demand side.

Such a project would have to be investigated to determine its feasibility and potential saving, thus it is only recommended as a potential improvement.

5.1.3 Recommendations for Mine C

The simplest method of obtaining an additional saving at this mine would be to repair and maintain the increasing air leaks on the air system. By reducing the air leaks and maintaining the compressed-air system, the original compressor control schedule can be implemented which will add an estimated additional saving of 0.6 MW to the evening peak saving.

As found with case studies A and B, the repairing of air leaks will add an additional energy efficiency saving to the daily savings. Additional evening peak savings can also be achieved if the ring pressure could be reduced further during Eskom evening period. It is recommended that hydraulic power packs, similar to the ones installed on Mine D, be implemented at this mine.

If the gold plant is supplied with its own supply of compressed air the system pressure at this mine can be reduced to 120 kPa during the Eskom evening peak.

If the required funds could be obtained to install an underground communication network, a follow-up project similar to the ones recommended for Mine A and Mine B could also be implemented at this mine. When compared to the present project cost, such a project would require massive financial investments with a minimal energy saving. Furthermore, when compared to Mine A this project has a low baseline and for that reason does not have as much energy saving potential as opposed to the percentage saving potential of Mine A.

5.1.4 Recommendations for Mine D

The first recommendation for Mine D would be to service one or more of the baseload compressors to allow the original compressor control strategy to be implemented. If one of the baseload compressors could be stopped, instead of being kept running in off-load mode, an estimated average demand reduction of 2 MW can be achieved during the Eskom evening peak period.

In addition to servicing the compressors, the system air leaks could also be repaired. This will not only add to the evening peak saving but it will also add an energy efficiency saving to the daily saving. This was clearly the case at Mine A and Mine B where air leaks were fixed and are now maintained.

To further improve the energy efficiency of the compressed-air system, a demand side project (similar to the ones discussed with the other projects) could be implemented at 4#. This would allow 4# to control its air consumption throughout the day and be more energy efficient.

5.2 Comparisons to other projects

To evaluate the potential and value of the implemented projects, they need to be measured against successful projects of a similar nature. Three projects were selected to serve as a benchmark and will be referred to as Mine E, Mine F and Mine G. On all three projects the compressors were automated, which allowed for automatic stop/start control from a central control node.

The infrastructure cost, target savings, achieved savings and time of implementation of these benchmark projects are listed in Table 16.

Table 16: Benchmark projects

| Mine | Infrastructure cost [ZAR]* | Target saving [MW] | Achieved saving [MW] | Implementation time [months] |
|--------|----------------------------|--------------------|----------------------|------------------------------|
| Mine E | 2,482,778.13 | 5.50 | 7.28 | 10 |
| Mine F | 7,965,383.60 | 9.00 | 12.70 | 12 |
| Mine G | 824,631.63 | 2.70 | 1.25 | 9 |

*All the above-mentioned projects were implemented in 2008. To compare the infrastructure cost to that of the case studies, 10% inflation has been added to the cost.

When comparing the savings achieved during performance assessment the benchmark projects either over- or underachieved by more than 10%. The case study projects remained within $\pm 10\%$ of their target savings during performance assessment.

To compare the cost of the projects, the cost per megawatt-hour (MWh) saved is calculated. This is calculated using the cost of the project divided by the energy savings achieved during the performance assessment. The cost per MWh presents a measurable comparison between the achievable energy savings and the cost of implemented infrastructure. The cost per MWh for all the projects is listed in Table 17.

Table 17: Cost per MWh

| Mine | Cost per MWh [ZAR/MWh] |
|--------|------------------------|
| Mine A | 326,881.48 |
| Mine B | 253,393.84 |
| Mine C | 328,859.67 |
| Mine D | 589,518.58 |
| Mine E | 341,040.95 |
| Mine F | 627,442.58 |
| Mine G | 659,705.30 |

When compared to the case study projects (Mines A–D), the cost per MWh for the benchmark projects was on average 30% more expensive to implement.

When compared to the target savings, the average percentage saving achieved during performance assessment for all the discussed projects, are listed in Table 18.

Table 18: Average percentage energy saving achieved

| Project type | Average percentage saving achieved |
|----------------------------|---|
| Benchmark projects | 106.57 |
| Case study projects | 101.25 |

In both cases the target saving was exceeded. On average, the benchmark projects achieved 5% more savings when compared to the case study projects during performance assessment period.

Table 19 lists the average time it took to implementation the various projects.

Table 19: Average time of implementation

| Project type | Average time of implementation [months] |
|----------------------------|--|
| Benchmark projects | 10.3 |
| Case study projects | 8.25 |

Based on these results, the conclusion can be made that the cost- and time-efficient methods, implemented during the implementation of the case study projects, were indeed effective. To determine the sustainability of the manual case study projects to that of the benchmark projects, the savings achieved by the individual projects were again measured after implementation. Random monthly savings after performance assessment were selected to compare the sustainability of the individual projects. The results are listed in Table 20.

Table 20: Post-performance assessment savings

| Mine | Eskom peak period saving [MW] | Percentage saving compared to the target saving |
|--------|-------------------------------|---|
| Mine A | 11.08 | 146.6 |
| Mine B | 2.36 | 62.4 |
| Mine C | 0.71 | 28.4 |
| Mine D | 1.80 | 57.9 |
| Mine E | 5.35 | 97.3 |
| Mine F | 18.61 | 207 |
| Mine G | 1.42 | 52.6 |

Table 20 shows that the benchmark projects (Mines E–G) continued to achieve similar savings when compared to the savings achieved during performance assessment. This shows that the proposed energy savings for these projects are sustainable.

The sustainability of the case study projects after performance assessment was influenced by the involvement of the particular mines. In the case of Mine A, the evening peak saving actually improved. The improved saving was as a result of the mine that continued to repair air leaks and maintain their compressed-air system after the implementation of the project was completed.

The savings achieved by the other three case study projects (Mines B–D), drastically decreased. This was due to the lack of manual control, increasing air leaks, unmaintained air system and in the case of Mine B, unforeseen hardware issues at the mine.

The hardware failure mentioned at Mine B referred to network and communication hardware that failed. This failure made it impossible to control the guide vanes of the one compressor from either the PLC, the SCADA or the REMS CM platform.

5.3 Conclusion

As shown in the previous section, all four case study projects were cheaper and faster to implement when compared to similar projects that were implemented with automated control systems. Despite the limited budgets, the case study projects also achieved similar energy savings when compared to the same projects.

Based on these results, the cost- and time-efficient DSM methods implemented on the mines' compressed-air systems were successful. The sustainability of the four case study projects had different results.

Although the achieved savings for all four case studies were sustained during performance assessment, the achieved saving after performance assessment varied. The energy saving achieved by Mine A was sustained after performance assessment because the mine continued to control the compressed-air system as it was done during performance assessment.

The energy saving at Mine A actually increased by almost 50% compared to the saving achieved during the performance assessment period. This was a direct result of the mine's commitment to continually maintain their air system and manage their air leaks. Based on these results, the savings potential of Mine A has shown to be sustainable.

The energy savings achieved by Mine B, Mine C and Mine D decreased by an average of 50% when compared to the savings achieved during performance assessment. As mentioned previously, Mine B suffered an unforeseen hardware failure that has influenced the achieved savings. Should this issue be fixed, the mine may achieve the proposed savings again, since they are still controlling the compressed-air system as it was done during performance assessment.

The decrease in the savings achieved by Mines C and Mine D was due to poor manual control in conjunction with increasing air leaks. The savings proved to be achievable during performance assessment, but due to poor manual control this

was no longer valid. The savings of these two projects have demonstrated not to be sustainable.

When all these results are taken into account, the final conclusion can be made that cost- and time-efficient DSM strategies can be implemented successfully on mine compressed-air systems. The proposed saving of these projects are achievable and sustainable if the mine is committed to the project and compressed-air savings initiatives. Mines should consider entering into a performance contract with ESCo's for sustainable savings.

APPENDIX:

Table 21: Treatment of public holidays during Megaflex periods [1.13]

| Date | Day | Actual day of the week | TOU day treated as | |
|-------------------|-----------------------|------------------------|---|------------------------------------|
| | | | NIGHTSAVE URBAN (Small & Large) | MEGAFLEX MINIFLEX |
| 2 April 2010 | Good Friday | Friday | Sunday | Sunday |
| 5 April 2010 | Family Day | Monday | Sunday | Sunday |
| 27 April 2010 | Freedom Day | Tuesday | Sunday | Saturday |
| 1 May 2010 | Workers Day | Saturday | Sunday | Saturday |
| 16 June 2010 | Youth Day | Wednesday | Sunday | Saturday |
| 9 August 2010 | National Women's Day | Monday | Sunday | Saturday |
| 24 September 2010 | Heritage Day | Friday | Sunday | Saturday |
| 16 December 2010 | Day of Reconciliation | Thursday | Sunday | Saturday |
| 25 December 2010 | Christmas Day | Saturday | Sunday | Sunday |
| 26 December 2010 | Day of Goodwill | Sunday | Sunday | Sunday |
| 27 December 2010 | Public Holiday | Monday | Sunday | Saturday |
| 1 January 2011 | New Year's Day | Friday | Sunday | Sunday |
| 21 March 2011 | Human Rights Day | Monday | Sunday | Saturday |
| 22 April 2011 | Good Friday | Friday | Sunday | Sunday |
| 25 April 2011 | Family Day | Monday | Sunday | Sunday |
| 27 April 2011 | Freedom Day | Wednesday | Sunday | Saturday |
| 1 May 2011 | Workers Day | Sunday | Sunday | Sunday |
| 2 May 2011 | Public Holiday | Monday | Sunday | Saturday |
| 16 June 2011 | Youth Day | Thursday | Sunday | Saturday |

Derivation of Equation (3.4) in Section 3.5:*Hagen-Poiseuille equation:*

$$h_L = \frac{32\eta Lv}{\gamma D^2},$$

Darcy's equation:

$$h_L = f \times \frac{L}{D} \times \frac{v^2}{2g}, \quad (3.3)$$

Substitute the Hagen-Poiseuille equation into the Darcy equation:

$$f \times \frac{L}{D} \times \frac{v^2}{2g} = \frac{32\eta Lv}{\gamma D^2}$$

Solving for f :

$$f = \frac{32\eta Lv}{\gamma D^2} \times \frac{D2g}{Lv^2}$$

$$f = \frac{64\eta g}{\gamma Dv}$$

But $\rho = \gamma / g$,

Therefore :

$$f = \frac{64\eta}{\rho Dv}$$

The Reynolds number is defined as $N_R = \rho Dv / \eta$,

Therefore :

$$f = \frac{64}{N_R} \tag{3.4}$$

Calculating cost of air leaks for Table 11 in Section 3.6.4:

Required variables:

| | | |
|------------------------|---------------------------------|--------------------------|
| System pressure | (P_{sys}) [kPa] | (500kPa for case study) |
| Atmospheric pressure | (P_{atm}) [kPa] | (87kPa for case study) |
| Absolute pressure | (P_{abs}) [kPa] | (587kPa for case study) |
| System air temperature | (T) [K] | (303.15K for case study) |
| Universal gas constant | (R) [N·m/kg·K] | (0.287 for air) |
| Cost per kWh | (C) [ZAR] | (R0.40 for case study) |
| Air leak hole size | (D) [mm] | |
| Density | (ρ) [kg/m ³] | |

Calculating airflow in cfm:

$$Q = 0.021 \times P_{abs} * P_{atm} \times (Q / 25.4)^2, \quad [cfm]$$

where 25.4 is used to convert metric units to imperial for this equation.

Converting cfm to cubic meter per second (cms):

$$CMS = CFM * 0.0004719, \quad [m^3/s]$$

where 0.0004719 is the constant for converting cfm to cms.

Calculating mass flow [3.7]:

$$\dot{m} = Q \times \rho \quad [kg/s]$$

Where the variables are:

- Density - ρ [kg/ m³]; and
- volumetric-flow rate - T [m³/s].

Power input required to produce the specified airflow [3.22]:

$$P = 165 \times \dot{m} \times \left(\ln \frac{P_{absolute}}{P_{atm}} \right), \quad [kW]$$

Where the variables are:

- Mass flow - \dot{m} [kg/ s];
- absolute pressure - $P_{absolute}$ [kPa]; and
- atmospheric pressure - P_{atm} [kPa].

Cost of an air leak per month:

$$\text{Cost per month} = P \times 24 \times (\text{days in a month}) \times C \quad [ZAR]$$

Calculating the pressure drop discussed in Section 4.2.

The required variables for the calculations are:

| | | | |
|--------------------------------|----------------|------------|--|
| Relative roughness of the pipe | (ϵ) | [m] | (0.00015 m for this application) |
| Temperature | (T) | [K] | (303.15 K for this application) |
| Pressure | (p) | [kPa] | (420 kPa for this application) |
| Pipe length | (l) | [m] | (3000 m for this application) |
| Pipe diameter | (D) | [m] | (0.59 m ID for this application) |
| Average air velocity | (v) | [m/s] | (measured average of 15 m/s) |
| Dynamic viscosity | (η) | [Pa.s] | (1.86×10^{-5} Pa.s for this application) |
| Individual gas constant | (R) | [N.m/kg.K] | (0.287 for air) |

The air density at the 420 kPa system pressure was calculated as follows:

$$\rho = \frac{p}{RT} \quad (3.1)$$

$$\rho = 4.83 \text{ kg/m}^3$$

The Reynolds number was calculated using the given variables and the calculated density:

$$N_R = \frac{vD\rho}{\eta} \quad (3.2)$$

$$N_R = 2.3 \times 10^6$$

Using the calculated and given variables, the friction factor for the system could be calculated:

$$f = \frac{1.325}{\left[\ln \left(\frac{\epsilon}{3.7D} + \frac{5.74}{N_R} \right) \right]^2} \quad (3.7)$$

$$f = 0.0126$$

Using all the calculated and given variables the pressure difference over the specific air line was calculated as:

$$\Delta p = 4f \frac{l}{D} \frac{\rho v^2}{2} \quad (3.8)$$

$$\Delta p = 33.47 \text{ kPa}$$