

A demand side management study model for an  
on-off heap leach pad

**LEON NEL**

12932469

Dissertation submitted in partial fulfillment of the requirements for the degree, *Master of Engineering* at the Potchefstroom Campus of the North-West University, South Africa.

Supervisor: Prof PW Stoker

November 2011

## **ABSTRACT**

In today's world it is imperative to understand that the power demand of industrial and mining operations should be as economical as possible. This is especially necessary with the inevitable depletion of our natural resources such as coal, oil and gas which is used in the production of electricity. Since no replacement is currently available for carbon based electricity in Southern Africa, there is significant pressure applied by utility suppliers to force consumers to use energy wisely. The challenge is to run plants as efficiently as possible by decreasing operation's electrical footprint. High electrical costs and tariffs are the next primary driver for plant owners to use electricity efficiently.

Whether applying for allocation of power to a local electricity supplier, designing for optimisation of capital and operation expenditures, managing operation peak demands or for all of the above, a consumer must have a method of evaluating the plant's demand side demand. Demand side consumption is the energy consumed by the consumer at the tie-in point to the supplier and is represented by a load shape. A study on how to reduce the demand of electrical energy consumed by the consumer at this interface is called a demand side management study or DSM study. A DSM study is part of a DSM process.

On existing plants where stakeholders would like to know their demand side consumption or load shape in order to implement a DSM process, measurements can be taken at the tie-in point (or also referred to as the point of interest). The question arises, what about clients that would like to conduct a DSM study (or the entire DSM process) on a greenfield project perhaps during the feasibility phase or basic engineering phase? In both cases very little information is available.

This dissertation presents a model as part of the DSM study on a uranium plant's leaching section for the client to use in his DSM process. The specific leaching technology to which this model is applied is called an on-off heap leach pad (OOHLP).

The process followed to obtain the load shape was firstly to conduct a search for other similar studies and operations in order to find useful information and techniques. The next step was to investigate and design a prototype plant based on the client's requirements as a case study project, namely Trekkopje Maxi located in Namibia. The equipment, components and their operational profiles were identified and from this a

mathematical formula was developed and a visual model was outlined. Finally the results were verified at selected points against the same calculated by an electrical software package's load flow simulation tool.

The OOHLP's model developed in this dissertation can be used in future studies to optimize the electrical design of leach pads.

## Table of Contents

ABSTRACT .....	i
List of Figures .....	v
List of Tables.....	vi
List of Formulas .....	vii
Abbreviations .....	viii
ACKNOWLEDGMENT .....	ix
CHAPTER 1 INTRODUCTION.....	1
1.1 Research problem.....	4
1.2 Research objective.....	4
1.3 Dissertation overview.....	5
CHAPTER 2 LITERATURE STUDY .....	7
2.1 Introduction .....	7
2.2 A look at the demand side management (DSM) process.....	7
2.3 DSM on OOHLP .....	10
2.4 Leaching technology .....	11
2.4.1 What is leaching technology .....	11
2.4.2 What is Heap leaching?.....	11
2.4.3 What types of Heap leaching technology is available?.....	12
2.5 The OOHLP technology.....	13
2.5.1 The basic concept.....	13
2.5.2 The Maxi project OOHLP application .....	19
2.6 E-tap .....	21
2.6.1 What is E-tap.....	21
2.6.2 Why use E-tap .....	21
2.7 Conclusion.....	22
CHAPTER 3 DEVELOPING THE MODEL.....	23
3.1 Introduction .....	23
3.2 Developing the model .....	23
3.2.1 The load study .....	24
3.2.2 Conveyor profile.....	27
3.2.3 Pump profile.....	28

CHAPTER 4 MODEL VERIFICATION .....	33
4.1 Introduction .....	33
4.2 Method .....	33
4.3 Comparing the results.....	40
CHAPTER 5 DUSCUSSION OF RESULTS.....	42
5.1 Introduction .....	42
5.2 Analysing the results .....	42
5.3 Discussing the results .....	44
5.4 Conclusion.....	45
CHAPTER 6 CONCLUSION .....	46
6.1 Introduction .....	46
6.2 Conclusion.....	46
6.3 DSM recommendation .....	49
6.3.1 Tariff synchronization .....	49
6.3.2 Load shape manipulations to exploit supplier low end tariffs.....	50
6.3.3 Reticulation equipment/component sizing .....	51
6.3.4 Continuous power factor correction .....	52
6.4 A final word.....	53
REFERENCES .....	55
APPENDIX A: The model.....	59
APPENDIX B: E-tap simulations .....	61
APPENDIX C: The process illustrated as a block flow diagram. ....	64
APPENDIX D: Examples of actual load lists .....	65
APPENDIX E: A compact laser disc (CD).....	66
E1 FLSmidth pad stacking and reclaiming simulation (requires VLC media player),.....	66
E2 The model as a spreadsheet (excel file) with extended load list and graphs, .....	66
E3 The E-tap file (requires the E-tap program and licensing). ....	66

## List of Figures

<b>Figure 1.1:</b>	<i>A top view of a OOHLP.....</i>	2
<b>Figure 1.2:</b>	<i>Trekkopje Uranium Project citing.....</i>	3
<b>Figure 2.1a:</b>	<i>A schematic illustration of a basic heap leach.....</i>	11
<b>Figure 2.1b:</b>	<i>A more illustrative basic heap leaching system.....</i>	12
<b>Figure 2.2:</b>	<i>The OOHLP layout or also referred to as the race track.....</i>	14
<b>Figure 2.3:</b>	<i>A stacker built by FLSmidth.....</i>	15
<b>Figure 2.4:</b>	<i>A photo of a bucket wheel reclaimer.....</i>	18
<b>Figure 2.5:</b>	<i>The OOHLP layout.....</i>	20
<b>Figure 2.6:</b>	<i>The Maxi pad with color coding for process step (cell 21 positions).....</i>	21
<b>Figure 3.1:</b>	<i>A plot of the pump and conveyor profiles illustrating the power requirement over the race track.....</i>	29
<b>Figure 4.1:</b>	<i>The base Single Line Diagram (SLD).....</i>	35
<b>Figure 4.2:</b>	<i>The composite networks representing the processes (Motor Control Centres).....</i>	36
<b>Figure 4.3:</b>	<i>Changing profile factor.....</i>	37
<b>Figure 4.4:</b>	<i>Changing the absorbed power factor.....</i>	37
<b>Figure 4.5:</b>	<i>An illustration of a load flow analysis result. This particular one indicates the installed power.....</i>	39
<b>Figure 5.1:</b>	<i>The load shape.....</i>	43
<b>Figure 6.1:</b>	<i>Illustrating the DSM process as set out by chapter two.....</i>	47
<b>Figure 6.2:</b>	<i>Illustrating a DSM study as followed by this dissertation.....</i>	48

## List of Tables

<b>Table 3.1:</b>	<i>Motor load list for the OOHLP.....</i>	<i>26</i>
<b>Table 3.2:</b>	<i>A break down, calculated by the formula for each cell position's power requirements.....</i>	<i>31</i>
<b>Table 4.1:</b>	<i>The position and profile factor used for each process in the simulation.....</i>	<i>34</i>
<b>Table 4.2:</b>	<i>The simulated values for the steps of interest.....</i>	<i>40</i>
<b>Table 4.3:</b>	<i>Comparing the models results with that of the software simulation package for the steps of interest.....</i>	<i>41</i>
<b>Table 5.1:</b>	<i>A quick estimation made to quantify the service loads for the OOHLP.....</i>	<i>44</i>

## List of Formulas

[1]	<i>Deriving the absorbed power for the load list given the nameplate data of a motor.....</i>	25
[2]	<i>Calculating the power required for conveyors in order to obtain the load profile.....</i>	27
[3]	<i>Calculating the power required for pumps in order to obtain the load profile.....</i>	28
[4]	<i>The OOHLF formula (model).....</i>	30
[5]	<i>Calculating the absorbed power from the installed power.....</i>	44
[6]	<i>Calculating the power demand from the absorbed power.....</i>	51

## Abbreviations

BEP	=	Bateman Engineering Projects
BTU	=	British Thermal Unit
CD	=	Compact Disc
CEO	=	Chief Executive Officer
COFC	=	Central Overland Feed Conveyor
DSM	=	Demand Side Management
ECB	=	Electrical Control Board (Namibia)
EPCM	=	Engineering, Procurement, Construction and Management
IDM	=	Integrated Demand Management
IIEC	=	International Institute for Energy Conservation
ILS	=	Intermediate Leaching Solution
MCC	=	Motor Control Center
MEL	=	Mechanical Equipment List
MSF	=	Mechanical Safety Factor
OHL	=	Over Head Lines
OOHLP	=	On-Off Heap Leach Pad
P&ID(s)	=	Piping and Instrumentation Drawing(s)
PFC	=	Power Factor Correction
PFD(s)	=	Process Flow Diagram(s)
PLS	=	Pregnatated Leaching Solution
ROM	=	Run of Mine
RPI	=	Rensselaer Polytechnic Institute
SLD	=	Single Line Diagram
SP&L	=	Small Power and Lighting
TRF	=	Transformer
UPS	=	Uninterruptable Power Supply
US	=	United States (of America)
VFD	=	Variable Frequency Drive (also VSD for Variable Speed Drive)

## **ACKNOWLEDGMENT**

The author would like to thank:

- His heavenly Father for giving him the strength, insight and knowledge.
- His family for the love and support with special mention to Lenie and Michele.
- Bateman for the use of company and project information.
- Professor Piet Stoker for his support, guidance and patience.

## CHAPTER 1 INTRODUCTION

Mike Bowlin (1999) the chairman and CEO of ARCO (now BP) said; “*We've embarked on the beginning of the last days of the age of oil [natural resources]. Embrace the future and recognize the growing demand for a wide range of fuels or ignore reality and slowly but surely be left behind*”.

Jimmy Carter the 39<sup>th</sup> US president and Nobel prize winner said that; “*We simply must balance our demand for energy with our rapidly shrinking resources. By acting now we can control our future instead of letting the future control us*”.

Given the above it seems that in today's World, energy savings starts as a paradigm shift. It requires costly research and financial tradeoffs. For companies to obtain power allocation or purchase agreements from a utility supplier it is compulsory to prove that every possible measure has been taken to ensure that the lowest possible energy consumption is required, i.e. operating efficiently as per the Namibian Electrical Control board (May 2006:3). Utility supplier representatives, such as Buys [Oct 2011] states that the common goal is to ensure the stability of the national power grid. Apart from the normal necessary efficiency study tools, companies must optimize their operation strategies as far as possible. Capital cost payback periods offers a means of negotiations and creates a win-win situation for both the electrical supplier and the customer. The problem is that, before any operational- or capital cost studies, such as a demand side management study on a new greenfield plant can be performed, the process or system needs to be studied, understood, modeled and/or represented in a load profile.

According to the International Institute for Energy Conservation (IIEC, 2006) end use(r) efficiency can be obtained by a DSM study and implementation, collectively called the DSM process. Demand side management is an engineering process applied on the consumer's energy demand to ensure that the least impact on the utility supplier is achieved. The consumer needs to ensure and prove that his energy requirements are as efficient as possible. This process is in the form of a study of the energy usage. The baseline consumption needs to be determined and analyzed and then remedied. More on the DSM steps are discussed in the chapter two.

For this dissertation the following project was used to obtain a load shape as part of a DSM for an OOHLP and the information obtained from Blake (2010):

The Areva Trekkopje Maxi project is situated  $\pm 65$  km North of Swakopmund in the Namibian desert. This is a new Uranium shallow open cast mine and is scheduled to be commissioned in June 2012. An On-off Heap Leach Pad (OOHLP) is used for beneficiation of Uranium oxide or “yellow cake” and it is estimated that the throughput of raw material of the pad will be 100 000 tons per day. Figure 1.2, p3 illustrates the citing of the Trekkopje project [Trekkopje Maxi design criteria].



**Figure 1.1:** A top view of a OOHLP taken from the FLSmidth website – conveyor section (Nov 2011).

A OOHLP is the facility to leach a mineral or product from the raw material. The material is stacked in heaps (*see figure 1.1*) and then sprayed by a solvent, usually an acid to “capture” or dilute the product into the solvent as it is trickle-fed via gravity through the heap.

Bateman Engineering Projects: Sub-Saharan Africa (BEP) was appointed the Employers’ Representative and is responsible for the design, engineering and procurement. The total project budget is set at US\$5.5 billion,



## 1.1 Research problem

Electrical consumers, when applying for power allocation, are required to demonstrate that their electrical consumption is efficient. In the case of a greenfields OOHLP such demonstration is particularly challenging, since a methodology to achieve this is currently non-existent. (ek het die greenfields oral reggemaak)

To rectify this deficiency, a methodology needs to be developed as part of the overall DSM process of an OOHLP design, that would provide the necessary evidence of efficient and optimum energy use of the OOHLP operation.

The methodology developed in this dissertation firstly conducts a load study. It then proceeds to develop an energy consumption model. This in turn is used to derive a load shape for the operation of the OOHLP. The latter can then be manipulated using several best DSM practices to achieve optimal electrical efficiency.

If applied to the Trekkopje Maxi project during the design phase savings, on both capital and operation expenditure can be seen. The consumer can then indicate a more accurate maximum demand figure in his application to the utility supplier.

## 1.2 Research objective

The primary objective for this dissertation is to develop a methodology to obtain a model for an OOHLP. This model can be used by others, such as the client in a DSM study as part of a DSM process. In order to develop such a model the following are required:

- Conduct a load study on the Trekkopje Maxi OOHLP and obtain the applicable load profile(s).
- Use the load study and profiles to obtain a mathematical formula for the Trekkopje Maxi OOHLP. This formula calculates the pads electrical consumption.
- From the formula's results a load shape are obtained. Statistical data to be used in a DSM study can be derived from the load shape.

With the research problem and objectives presented the rest of this chapter gives an overview of the dissertation.

## **1.3 Dissertation overview**

The chapter structure of the dissertation proceeds as follows:

### **Chapter 2: Literature study**

In this chapter the following are presented:

- A discussion on demand side management,
- A discussion on heap leaching and the OOHLP's process,
- A discussion on the software program used to simulate and verify the model.

### **Chapter 3: The mathematical model**

In this chapter the load study, model and results are presented and discussed. The load study is presented as a load list and then extended to illustrate the load profiles. The load profiles are the dynamic power consumption behavior of the equipment(s) such as pumps and conveyors over the course of the OOHLP process. The extended load list serves then as input to the pad model and is then represented as a colorful spreadsheet illustrating the OOHLP 300 day cycle. The individual steps are then presented in a table.

### **Chapter 4: Verification**

The results are verified using an electrical engineering software package called E-tap. The load list from chapter three is used to draft a single line diagram as a base for the program. Then the absorbed power factor and the individual load profile factors are entered to simulate the points of interest. Finally, the model's results are discussed and compared to the results obtained from load flow analysis.

### **Chapter 5: Results**

In this chapter the results obtained from the two previous chapters will be presented and discussed, highlighting specifically statistical information that will be used in the DSM. In addition to the scope of the dissertation the service power is also discussed and included.

## **Chapter 6: Conclusion and recommendation**

In this chapter recommendations for the use of the model and its results are discussed. These are typically; synchronization with the national tariffs, typical load shape manipulations and application of the diversity factor and power factor correction.

### **Appendices**

The model calculation sheet, extended load list, E-tap simulations and an overall process block flow diagram are attached for further reference. A compact disc (CD) with the spread sheets used to calculate the model, the E-tap files and a movie clip illustrating the stacking and reclaiming of the pad are attached.

AS part of the literature study the required concepts and tools to develop a DSM model for the OOHLP is discussed in the next chapter. This includes the DSM process, leaching and leaching technologies, the conceptual design for the OOHLP and E-tap the software program.

## **CHAPTER 2    LITERATURE STUDY**

### **2.1        Introduction**

To conduct a DSM investigation, a clear understanding of the DSM process and of certain concepts pertaining to the OOHLP was researched. Sound knowledge of the OOHLP process, technology, the equipment and its behavior is required. The forces on the pad due to its orientation and its impact played an important part of the equipment's power requirements and are discussed here. Also, the tools and calculations used in this investigation are addressed and illustrated. To complete this literature survey, similar project implementation were investigated.

The literature is thus presented as:

- A look at the demand side management process.
- A report on existing DSM studies on an OOHLP.
- A discussion on Leaching, heap leaching and a typical on-off heap leaching pad process.
- A discussion on the Trekkopje Maxi heap leach pad process.
- A discussion on E-tap the software program.

### **2.2        A look at the demand side management (DSM) process**

From all the information available the author identified and used the four most applicable sources. The investigation looked at an international report from the IIEC (Jul 2006), the South African governing utility supplier's webpage on DSM named Eskomidm (Jun – Oct 2011), a PhD thesis by the North West University (Jordaan, Nov 2007) and lastly, a Namibian DSM report (ECB, 2006).

The references given above all concur that a DSM is a study of a customer's energy consumption. The consumer's energy consumption should be as efficient as possible and have the minimum impact on the

utility supplier and the environment. Although the electrical consumption is used as the measure, it does not necessarily mean that the DSM remedies should be limited to electrical efficiency only. Mechanical loads can be designed or changed in order to use less energy. The process and process layout can also be designed (or be modified) to reduce the electrical footprint. (Lowth, 2011)

What the author found extremely interesting from discussions with the South African utility supplier (Buys, Oct 2011), is that it seems in South Africa and Namibia there is confusion around DSM. Eskom, the South Africa utility supplier and supplement supplier to Nampower, the Namibian utility supplier has got an incentive scheme as part of a DSM program (Eskomidm, Oct 2011).

According to Eskom (Eskomidm, Oct 2011) the IDM's role is to ensure single ownership of demand side management strategies, objectives and operations throughout Eskom. It takes a market-driven approach to understanding and meeting consumer requirements and provides a platform from which Eskom can collaborate with government, external stakeholders and consumers.

A consumer has the opportunity to prove that he reduced his electrical requirement using more efficient techniques. The utility supplier will then compensate the consumer depending on whether his reduction qualifies and by how much. It seems that this is confused for DSM, in the sense that a DSM is only a DSM if an incentive by the supplier is given. DSM is a "tool" to obtain information on and then manage and remedy your electrical consumption.

According to the IIEC (2006, 10) the process for a DSM study is:

1. To conduct a load research.
2. To obtain a load shape (either via monitoring or a model).
3. To define the load shape objectives (the deliverable of this report).
4. To assess the program and implementation strategies.
5. To implement the strategies as per no. 4.
6. Monitor, evaluate and continuous improvement.

Considering the IIEC (2006), Buys (Oct 2011), Eskom IDM (Oct 2011), Jordaan (2007) and the Namibian ECB (2006) the Author proposes that for the purposes of this dissertation DSM is:

*DSM is an engineering process with the goal to consume electrical energy as efficient as possible when evaluated at the point of connection between the supplier and the consumer regardless of if any incentive is given. The benefits for consuming energy more effectively should be enough of an incentive. It also doesn't matter whether DSM is conducted during the design phase of a project or on an existing plant as long as the customer ensures that he is applying himself to the wellbeing of our natural recourses.*

Two definitions used above need more clarification:

*Point of connection:* This is generally the battery limit between the supplier and the consumer, but this is not always the case. What if there is an internal relationship on the consumer's section (as found with this investigation), where the OOHLP is considered as a section on its own? The point of connection can thus be seen as any point where the electrical consumption needs to be evaluated, i.e. the point of interest.

*Energy efficiency:* High energy efficiency can be achieved by maintaining energy losses across a system to as low a level as possible. In electricity that translates that the real power (watts or kilowatts) should be use effectively and the reactive power (VAR or kVAR) should be as little as possible.

There are many ways to achieve good energy efficiency (which is the ultimate goal or deliverable for a DSM) at the point of connection, but the author sees it on a high-level as:

*In the industrial and mining industry efficient electrical energy usage is achieved by;*

- *a well designed, operated and managed process,*
- *high efficiency reliable and suitably sized equipment,*
- *reticulation system with very little losses*
- *and a low or best achievable power factor.*

Measuring and then evaluating the energy consumption is probably the most common way of obtaining a load shape for a DSM study (Buys, Oct 2011). This is to measure the energy consumption on an existing plant at the point of interest and obtain a load shape that will be analyzed. The problem is that according to Chitongo (2010) the plant's consumption will only stabilize three years into operation. So only then will accurate information be available to read and conclude on a load shape. What if the plant doesn't exist or is not built yet, as in the case of the Trekkopje project? How will the load shape then be obtained?

When the plant point of interest is not available for measurement (for whatever reason), a load study can be conducted on a theoretical model of the plant. Using mathematical equations, a load representation or formula can be obtained. How can the model be proven to be satisfactory? As with this investigation an electrical software package can be used to verify the results. Another way is to compare it to previous projects, but what if no project of this nature can be found (as with this project)? The model must be calibrated and confirmed once the plant is constructed and commissioned. The model results must be compared to energy meters metering at the relevant points during operation, preferably during the second or third operating cycle (after the first 300 days).

To summarise, before a DSM study can be conducted on a new plant (commonly called a greenfields plant in the EPCM business) a load study needs to be done. In order to do this the process and operations need to be understood and well defined. In the next section the availability of information for a DSM on an OOHLP is discussed and in the following sections the technology and the process required for the load study of the Trekkopje Maxi project is explained.

## **2.3 DSM on OOHLP**

A literature survey was conducted to find any previous DSM work or DSM related work on an OOHLP. This was done in order to find information that might assist in achieving the objectives for this dissertation. Key words such as leach pad, on/off heap leach pad, dynamic leach pad, leaching, etc. or any combination of these were used. Even when adding DSM or energy efficiency with the above no direct or usable information was found. This survey was conducted on all the databases available to the author and by experienced persons. Also several experts in the field of DSM were contacted such as van Rensburg (Oct 2011), Buys (Oct 2011), Lowth (Aug 2011), Grobbelaar (Oct 2011). These experts hold no knowledge of any previous DSM related work on an OOHLP.

The Author is of the opinion that this is the first load shape and subsequently the first model for a greenfield OOHLP. The information and methods used in the following sections and chapters was obtained by:

- Consulting experts in the field of DSM studies and OOHLP technology.
- Using the Bateman design team to assist in completing the load study (a preliminary design).
- The information from the above experts and team members used will be noted in the document and can be found in the documents references.

## 2.4 Leaching technology

### 2.4.1 What is leaching technology?

According to RPI (Oct 2011) and Claasens (Oct 2011), in general, leaching is the process where the mineral or product is separated by dissolving it into a solution and thereby removing it from the unwanted or useless material. It is a chemical process and is popular in the mineral industry. There are several different types of leaching processes, but the one that is applicable for this dissertation is heap leaching technology.

### 2.4.2 What is Heap leaching?

Consolidating the RPI (Oct 2011), Claasens (2010 - 2011) and Weston (2010 - 2011) heap leaching is a countercurrent process where a solvent is percolated through material that is stacked on a heap. As the solvent, usually an acid such as cyanide, is percolated through the material. It then becomes “impregnated” with the required mineral/product, i.e. absorbs the product. From this the product is normally gravity fed to ponds where it is stored to be further processed. The solvent is pumped to the heap and normally sprayed or sprinkled over the pad. See the figures 2.1a and 2.1b below. In the next section the types of heap leaching are discussed.

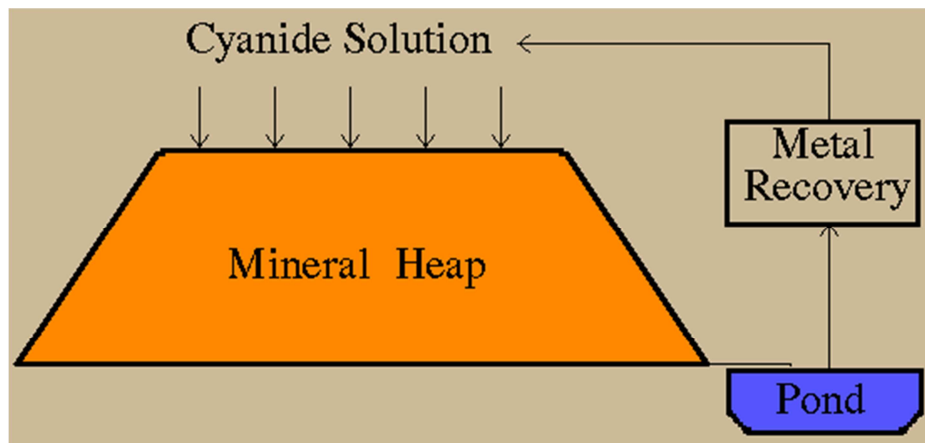

**Figure 2.1a:** A schematic illustration of a basic heap leach obtained from the website of the RPI (Oct 2011)

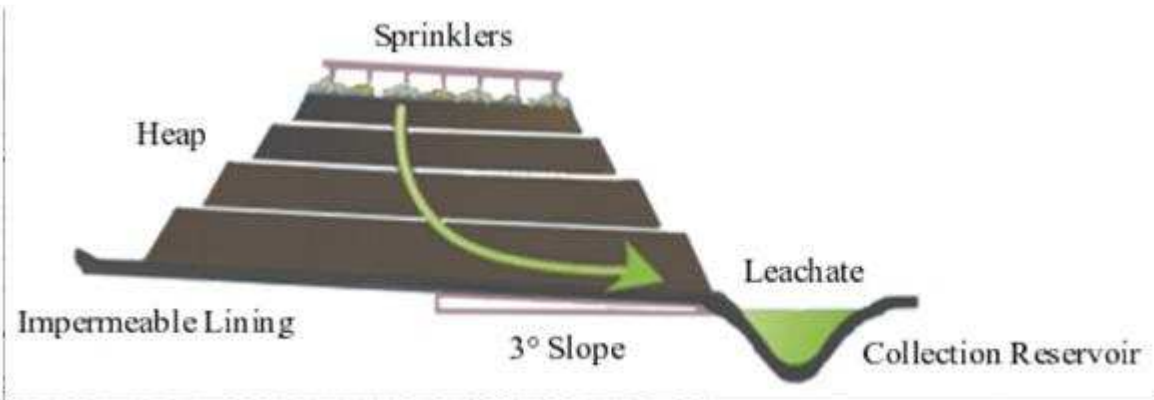

*Figure 2.1b: A more illustrative basic heap leaching system (Burgess, 2011)*

### **2.4.3 What types of Heap leaching technology are available?**

Using Jansen and Taylor (June 2011, 2 & 3) and Kappas (2011) the information below was obtained about the available technologies of heap leaching:

Metals that can be removed by the heap leaching process are gold, silver, copper, nickel and uranium. Presented below are the more common types of heap leaches:

- **Permanent single/multiple lift heaps**  
These are once-off type heaps. They are stacked and once the leaching process is completed become waste heaps. They are large prominent heaps and their life is determined by the amount of ore stacked. They will later be rehabilitated with fauna and flora as far as possible.
- **Planer or valley filled heaps:**  
These are the same as the permanent single heaps, but are stacked in existing natural bodies. The shape of the natural surroundings, such as a valley facilitates the process. This is done with the natural inclinations that will assist with the gravity fed system. It usually saves capital expenditure on civil works required for a project.
- **Run of Mine (ROM) dump:**

This is a batch type of leaching process using a ROM pile. A ROM pile is a singular, non movable and pre-treated lay down area (footing) that is filled with material using a conveyor and chute. The waste is later removed by feeders such as apron feeders, belt feeders or vibrating feeders. This is a stop/start (batch) process and not a continuous process. The process throughput is therefore inconsistent.

- On-off heap leach Pads (also known as dynamic or continuous leach pads)  
This is performed by using the same footprint over and over again, stacking ore, treating the heaps stacked and then removing the waste. The life of the mine is not determined by the amount of material stacked on the heaps but rather on the ore deposit.

For this investigation, an On-Off Heap Leach pad was used. In the next section the on-off or dynamic heap leach pad process are discussed.

## **2.5 The OOHLP technology**

### **2.5.1 The basic concept**

The basic OOHLP concept discussed in this section is as per the collective information obtained by the author from discussions with Claasens (2010 - 2011) and Weston (2010 - 2011) and a technical report by U.S EPA (1994, 1 - 16).

What makes the OOHLP different from the other leaching options and a more attractive solution is that it is reusable and continuous. The pad surface area is lined with a rail track which is called a race track, i.e. the working surface. This rail track is the footing on which the stacker and reclaimer moves, much like a train. Caterpillar tracks can also be used (as with army tanks). The OOHLP is made up of different simultaneous processes, so that at no one point production is stopped to wait for another process.

The pad is made up of sections and is typically in a circular form or, more commonly, an elliptical form. This is to ensure ease of continuity. Please refer to figure 2.2 for an example on the configuration of an OOHLP. This picture was taken from the FLSmidth website. FLSmidth is a supplier of stackers, reclaimers and conveyor systems and are represented in South Africa.



**Figure 2.2:** *The OOHLP layout or also referred to as the race track (FLSmith website – conveyor section (Nov 2011)).*

The process starts with a stacking step in order to start the heap on the first cell. After the stacking step, a preparation phase follows where the sprinkler and pipes are installed on the first cell. This means, when the sprinklers are installed, that the stacking system has advanced one cell, i.e. the preparation work continues on the first cell while the stacker stacks on the second cell. Whenever a new process is introduced, or a second stage of the previous process, the stacker and subsequently all the other processes will advance by one cell. This concept will be used continuously in the next sections and will not be repetitively explained. In order to imagine the movement of the entire process, think of the process as a dog chasing its own tail.

The process for a typical OOHLP is thus in the sequence as below:

1. Stacking
2. Piping and spray preparation
3. Wash
4. Leach
5. Rinse
6. Reclaim
7. No energy consumption (usually maintenance or preparation work is done here)
8. Install/Remove section

The above steps are individually discussed in more detail in the next sections and can also be seen in the overall block flow diagram in appendix D.

### 2.5.1.1 Stacking:

Consulting van Niekerk (2010) and using the FLSmidth website (Jan – Oct 2011) the following information was obtained for stacking:

The ore is stacked on a cell using a stacker. A conveyor conveys the material from the preceding process such as a screening building or agglomeration drums located elsewhere to the stacker. On the attached CD (Appendix E) a video simulation shows exactly how the heap is stacked and reclaimed. The stacking system might vary in complexity, but it must ensure that the heaps are stacked according to design. A lot of emphasis (time, money and quality) is placed on the heap design and layout to ensure that the optimal amount of product mined is leached. Please refer to figure 2.3 for an illustration of a stacker as found on the FLSmidth website.



**Figure 2.3:** A stacker built by FLSmidth (FLSmidth website (Nov 2011)).

Typical components that the stacking system comprises of are:

- Conveyors,
- stacker system,
- movable equipment,
- trailing cables,

- etc.

Components of interest for this investigation:

- conveyors (the dynamic portion of the load)

#### **2.5.1.1.1 Wash**

In this process step the cells stacked (or heaps) are washed to remove any material or “dirt”. Several stages, one after the other of the same process can be used to accommodate for different degrees of water purity and the effectiveness of the wash. For example, an initial wash can be done with dirty water which comes from a previous wash step (cycle) and the subsequent washed with clean fresh process water. The water captured from the clean water wash can be used in the dirty water wash next time. The reason for this is to keep the wash water cleaner for longer by using dirty water for a first wash (to capture all the real or bulky dirt).

Typical equipment for the wash step are:

- Large Pumps (which will be VFD driven),
- Long runs of pipes,
- Control valves,
- Flow and pressure meters,
- etc.

Components of interest for this investigation:

- Pumps (again the dynamic portion of the load)

#### **2.5.1.2 Leaching**

In this stage the product is obtained. The solution is sprinkled and leached through the heap. The chemical process between the solution and the heap material ensures that the product is taken up into the solution (or impregnated), drained from the heap and is then captured below. It is then removed using a gravity fed piping system. The piping system is installed in such a way that gravity is used to remove the leached solution, i.e. the angle of the capturing pipes and distribution pipes allows gravity to “pull” the solution to the storage ponds or tanks (see figure 2.1b).

Again as with the washing process, several stages or leaches can be undertaken using different levels, purity or percentage contaminated solution. Each of these will occupy its own cell. For example, if there are five different levels of wash, leach or rinse (as per next paragraphs) then five cells will be occupied.

Typical equipment that make up the leaching section:

- Large pumps (these will be VFD driven).
- Long runs of pipes.
- Control valves.
- Flow and pressure meters.
- etc.

Components of interest for this investigation:

- the large pumps

### 2.5.1.3 **Rinsing**

Rinsing is the process step where the heap, now known as depleted cells due to the absence of product, is rinsed to remove any leftover solution. The plant is treated to be environmentally friendly and therefore no residual acids and/or uranium must leave the pad. Usually water, dirty water or degree of dirty water is used to rinse the heap. Again several stages can be used as above.

Typical equipment:

- Large Pumps (Can be VFD driven).
- Long runs of pipes.
- Control valves.
- flow and pressure meters.
- etc.

Components of interest for this investigation:

- Large pumps.

#### 2.5.1.4 Reclaim



*Figure 2.4: A photo of a bucket wheel reclaimer (Bumigeme inc. website, Oct 2011)*

A mechanical piece of equipment or system is used such as a bucket, drum, or wheel reclaimer to “pick up” or reclaim the depleted material or now called waste. It is transferred from the reclaimer via a conveyor to the waste areas or also generally called the waste dumps. On the attached CD (Appendix E) a video simulation vlc-file shows exactly how the heap is stacked and reclaimed. Front-end loaders and hoppers with the conveyor can also be used.

Typical equipment:

- Reclaiming system.
- Conveyors.
- movable equipment.
- etc.

Components of interest for this investigation:

- conveyors (again the dynamic portion of the load)

### 2.5.1.5 **Install/remove preparation phase**

On the top of each cell's heap (if there is material on) is a sprinkler system to spray the heap with either water, impure water, the solution or version of the solution depending on the process stage.

## 2.5.2 **The Maxi project OOHLP application**

The project Piping and Instrumentation Diagrams (P&IDs, 2010) and the Process Flow Diagrams (PFDs, 2010) were used to obtain the information presented below. The process engineer Weston (2010) was also consulted.

As note it is worth mentioning that according to Pretorius (2011) engineering companies such as Bateman attracts potential clients by the specific process knowledge and expertise the companies has. This knowledge and expertise in specific mining processes resides with the process engineers. In other words, in general the reputation of the process engineers are in large mainly part of the reason why prospective clients are interested in Batemans business.

Refer to figure 2.6 for the Trekopje Maxi project set out as per Bateman's drawing office Valasis (2010). The 30 blocks are the physical pad (or race track), with the ponds and pumps to the bottom left and the waste, agglomeration and screening section to the bottom right.

The Maxi project is based on the typical OOHLP process as discussed in the previous section. It uses a:

- stacking process.
- two wash-one steps.
- two wash-two steps (or fresh water washes).
- one wash-drain.
- five pregnant leach solution (PLS) leach steps.
- five normal leach steps or intermediate leaching solution (ILS).
- five barren leach steps, one rinse step, one rinse-drain step.
- one reclaim step.
- four maintenance steps (setting up or maintaining the gravity fed piping system).

- and one install remove irrigation systems on top of the heaps.

Please refer to figure 2.5 for an illustration. This figure was put together by the author using the information discussed in this section.

The total process cycle last 300 days, of which every 10 days the pad moves one position (or a step), i.e. a cell is covered by a step for 10 days.

In the next section the software, which will be used to verify certain points of interest (Chitongo, 2010) will be discussed.

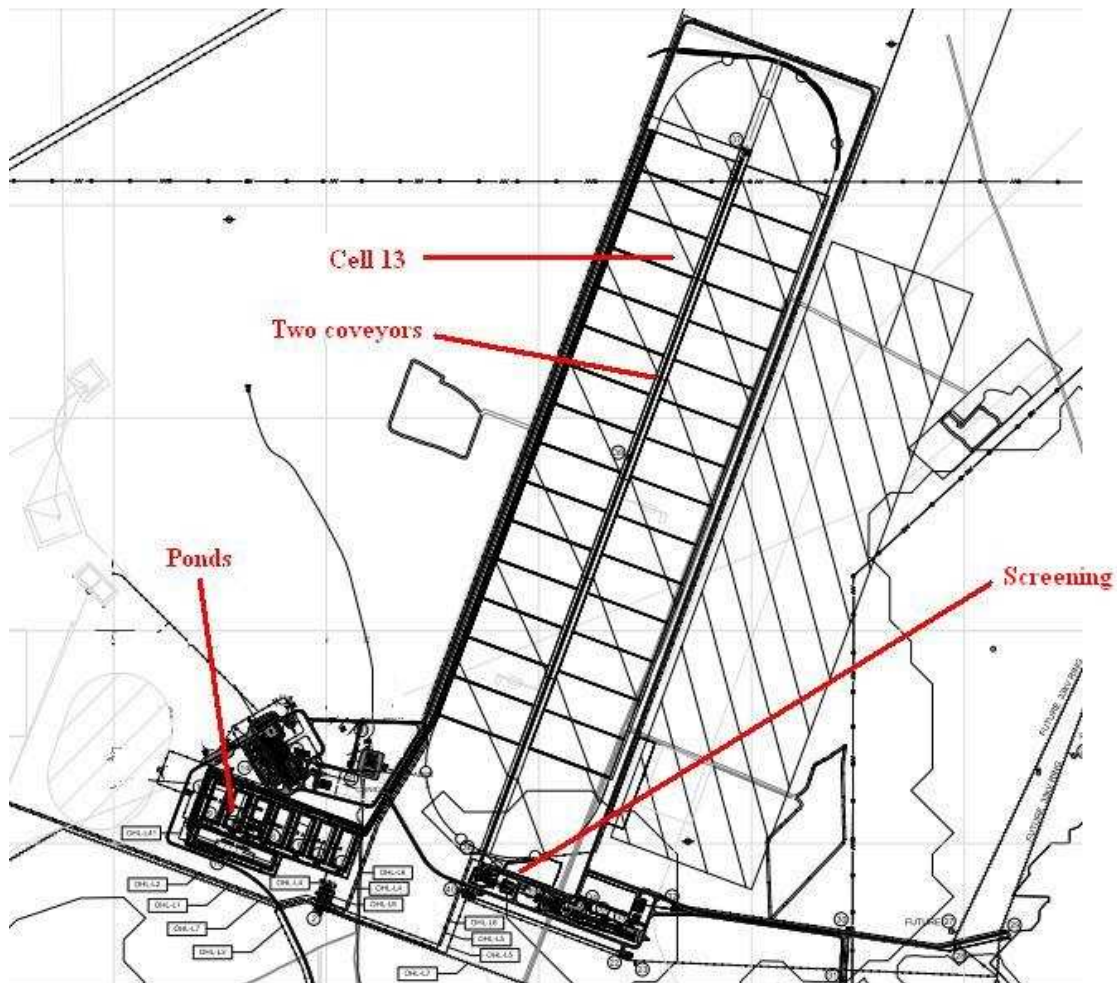

*Figure 2.5: The OOHLP layout (Valasis, 2010)*

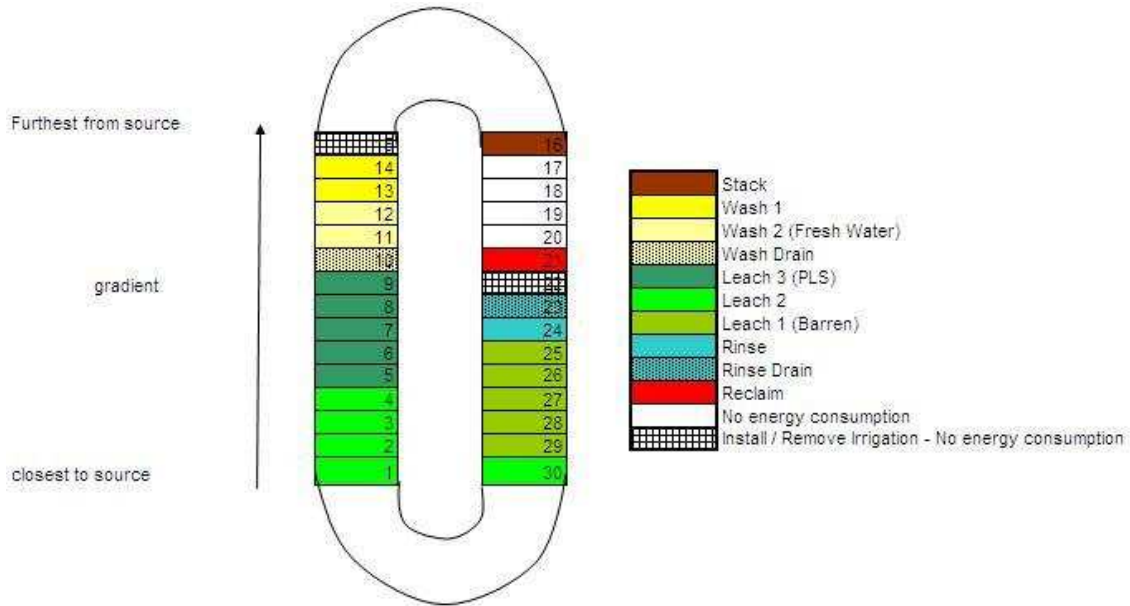

**Figure 2.5:** The Maxi pad with color coding for process step (cell 21 positions) (Nel, 2010)

## 2.6 E-tap

### 2.6.1 What is E-tap

From the E-tap website (2010) it can be seen E-tap is a software package described as an electrical engineering software tool or more specifically a transient and analysis program. With this tool an electrical engineer can design, simulate, size, verify, report, present, etc. on an electrical system using a normal laptop or personal computer.

It offers a fully integrated electrical engineering software solution, which includes a load flow analysis platform, short circuit analysis; relay coordination, optimal power flow system analysis and much more.

### 2.6.2 Why use E-tap

To verify the model's results a load flow analysis is required. According to Pretorius (2011) and Boatke (2010) e-tap is ideal to simulate a pre-design electrical model and calculate the load flow. The design and

model should be translated into the form of a single line diagram (SLD). For this dissertation the SLD was derived from the overall SLD designed by McGhee (2010) and plotted by Valasis (2010 - current).

The program is easy to use and the author is a trained user and proficient with the program.

The program is preloaded with libraries (technical information sets) for all of the equipment used in the load study. The technical information is readily available for use in the program or outside of the program (as with the manual calculations).

The question then is, why not use E-tap from the start to obtain the load shape? It is not ideal to design from first principles in E-tap. The design is usually done on a SLD, which is based on a load study and model. The SLD *can* be produced in E-tap, but a load study or model is still required. Also, most consumers (or clients) do not have a license(s) for the program. E-tap is an expensive engineering tool and is usually only used by large engineering companies. It is therefore a powerful tool able to deliver a manual model that a consumer can manipulate in order to predict the plant's consumption from a load shape.

## **2.7 Conclusion**

From chapter two, it is clear that this investigation was unique in the sense that no similar DSM for an OOHLP has been undertaken before. It has been found that studies on energy consumption were performed by way of reading energy meters once the plant has been in operation for three to four years in its life cycle. It follows that the consumer is not properly informed on the OOHLP energy consumption and associated costs prior to plant start up.

Moving forward, with the:

- research of leaching- and on-off heap leaching technology completed,
- no similar investigation found to benefit from,
- the research done on the Maxi OOHLP,
- and the E-tap software understood,

a model for an on-off heap leach pad is further developed in the next chapter.

## **CHAPTER 3    DEVELOPING THE MODEL**

### **3.1        Introduction**

In this chapter the necessary steps and calculations are done to develop a model for an OOHL. Also a discussion is included on the calibration and validation of the model. The model essentially is a mathematical formula representing the OOHL's process. The formula calculates the load shape which can be used in a DSM.

In order to develop a formula for an OOHL model a load study is required. The load study is conducted by identifying the load for each process step as set out in chapter two. These loads consist of motors driving pumps or conveyors. Once identified and sized they are then presented in a load list. For each process step a pad profile is then developed as a function of its load profiles across the pad. A load profile (or a motor profile) represents the electrical power consumption for that motor over the entire pad process. The next step is to add the load profiles to the load list. As mentioned in Chapter 2, the entire pad process period consists of 30 steps, covering 30 cells over 300 days.

Then the individual component profiles were summated and incorporated into the spreadsheet to illustrate and calculate the pads consumption per step. The results for the 30 steps are presented in a table.

### **3.2        Developing the model**

The basic concept of the model is that there are different processes involved and these processes happen in sequence or in a certain order as explained in Chapter 2, section 2.4.2. There are 30 possible variations or steps, i.e. every process (step) allocates to- or occupies a cell in the cycle once. When a process occupies that same cell again it means that the process has restarted.

Considering the scenario where the reclaimer is on cell one it means that the entire processes are present on the pad and that the entire OOHLP process has been around the pad at least once. This scenario is used as position one, i.e. position one is when the stacker is on cell 27.

The pad demand power, without including for reticulation- and drive losses, is equal to the sum of the entire process load's consumption (all the processes) as a function of the process positions. To calculate the power consumed by the pad when it is in a position n the following is used:

$$P_n(kW) = \sum_{\text{all the processes}} ((process_k) \times ppf_{k+n})$$

Or, as in the case for position one;

$$P_1(kW) = \sum_{\text{all the processes}} ((process_k) \times ppf_{k+1})$$

Where;

- $P_n$  (kW) = the total power, in kW, used by the pad in that specific position n or scenario, i.e. “demand side power requirement”
- $ppf$  is the profile factor as explained in section 3.2.1 (not to be confused with “power factor”). ( $ppf = y_n$  for a pump or  $x_n$  for a conveyor).
- $process_k$  = the absorbed power of a process' load as indicated by the load list. The process step is determined by k.
- k is the process step positioning indicator, i.e. Barren is k = 6 or Wash2 is k = 20, etc.

In order to develop and populate this equation further, the following two typical profiles need to be obtained; one for a typical pump and one for a typical conveyor. These can be used as the blueprint for all the conveyors and pumps associated with the pad. Next the loads that will use these profiles need to be identified as part of the load study.

### 3.2.1 The load study

To better illustrate the components as discussed in Chapter 2, a high level electrical load list is presented. The electrical load list, when used as a spreadsheet, calculates and presents the absorbed power for each piece of equipment as seen from the very furthest cells, cells 15 and 16. This will represent the absolute worst case

for that particular load (which is a combination of motors). The absorbed power, obtained from the mechanical department in the form of a mechanical equipment list or MEL, was used in this investigation as this is the actual power requirement that at the point of interest.

What simplified this exercise was that the loads consisted only of three main categories namely pumps, conveyors and static loads. The only static loads are the stacking and reclaiming systems.

At this stage it is worth mentioning that using a motor's installed power to calculate the absorbed power is reverse engineering. When the project is in its detailed engineering phase, the absorbed power will be calculated by the mechanical engineers from the physical torque requirements. At this stage the sizes of the loads are determined by previous experience of engineers such Redelinghuys (2010) en van Niekerk (2011). These estimates are presented in a MEL with project number M7348-M880-001 (2010, 1- 4).

The formula used to derive the absorbed power presented in the load list in table 3.1 with information used from Bateman load lists (M7348-E831-001, 2010) is:

$$P_{abs} (kW) = \frac{(P_{inst} \times Msf \times df)}{eff} \quad [1]$$

Where;

$P_{abs}$ (kW)	=	Absorbed power of the motor.
$P_{inst}$	=	Installed power of the motor (nameplate rating).
$Msf$	=	Mechanical safety factor, which is usually 0.8.
$df$	=	Diversity factor, which is in the basic engineering an estimate of 0.9.
$eff$	=	Motor or load efficiency.

Description	No. of motors	Inst kW	MSF	UDF	EFF (load) (E-tap)	Abs kW
Central Feed Overland Conveyor	4	1100 x 4	0.8	0.9	0.945	3352
Reclaim Conveyor	2	1100 x 2	0.8	0.9	0.9414	1682
Stacking System Package	Vendor	1990	0.8	0.9	-	1992
Barren Solution Pumps	3	3 x 800	0.8	0.9	0.9362	1846
ILS 1 Pumps	3	3 x 800	0.8	0.9	0.9362	1846
ILS 2 Pumps (Additional options)	3	3 x 800	0.8	0.9	-	
Wash 1 Pumps	2	2 x 560	0.8	0.9	0.9343	863
Wash 2 Pumps	2	2 x 560	0.8	0.9	0.9343	863
Rinse Pumps	2	2 x 400	0.8	0.9	0.9326	618
PLS Pumps	2	2 x 250	0.8	0.9	0.9301	581
Reclaimer System Package	Vendor	2850	0.8	0.9	-	2052
Total Abs kW (rounded up)						15.7 MW
Total Inst kW (not including standby units) (rounded up)						19.8 MW

**Table 3.1:** Motor load list for the OOHLP as per McGhee (2010, rev A)

The load list in table 3.1 is only for discussion purposes and to simplify the presentation. Examples of actual load lists that can be used in such a DSM study are shown in Appendix D. This will provide the reader with a better understanding of the typical information available on such a load list.

With the load list and the absorbed power for each load obtained, the pad profiles for the pumps and conveyors can be generated. The load lists from this section and load profiles in the next sections were obtained by consulting van Niekerk (Feb – Jun 2011) a lead mechanical engineer, Redelinghuys (Feb – Nov 2011), a lead mechanical engineer and Malan, a mechanical engineer (Aug – Nov 2011). Also the Bateman preferred suppliers Cotterrell (2010) and Kruse (2010, 14 -17).

The pad profile for a piece of equipment comprises of a set of percentages. For example, if cell 8 is 2km from the barren solution pump and the profile indicates cell 8 as 50% it means that the pump is using half the worst case power. The worst case power is the absorbed power and is listed in table 3.1 as 800kW at cell 15 and 16. This means that at cell 8 the barren solution pump only uses 400kW. With a pad profile the power requirement can be determined for a pump on every cell.

As earlier mentioned, only three types of profiles are included of which only two can be represented as a dynamic or as a changing profile. These were pumps and conveyors.

### 3.2.2 Conveyor profile

There are two conveyors that form part of this study, i.e. the pad feed conveyor or central overland conveyor (COFC) and the waste removal conveyor. These will eventually both be  $\pm 4$  km long and runs up and down in the center of the pad respectively. The pad feed conveyor delivers the uranium rich material to a specific cell via a stacker. The reclaimer takes/removes the depleted or waste material from a specific cell. It then transfers it on to the waste removal conveyor which conveys it to the waste piles or dumps. .

Using the consultants listed in the previous section with special mention of Malan (Oct 2011) and APEX FENNER (2002, section 3 – 7) the key variables that were used to derive the conveyor profiles were:

- Distance
- Product- or waste weight
- Friction
- Losses

These were fed into the formula:

$$P = Fv \quad [2]$$

Or

$$\text{Power (W)} = \text{Force (N)} \times \text{Velocity (m/s)}$$

Where the force (F) depends on the system friction (idlers, pulleys, scrapers, skirting), conveyor lift (height material is lifted) and capacity (tons/hr). In general, it depends on the distance and height the conveyor system needs to carry the material.

The results when applying the formula to the pad, done by the mechanical department gave the following series  $x_n$ ;

$$x_n = \{24\%, 28\%, 32\%, 36\%, 40\%, 44\%, 48\%, 52\%, 56\%, 60\%, 64\%, 68\%, 72\%, 76\%, 80\% \dots$$

$$\dots 80\%, 76\%, 72\%, 68\%, 64\%, 60\%, 56\%, 52\%, 48\%, 44\%, 40\%, 36\%, 32\%, 28\%, 24\%\}$$

Plotting  $x_n$  resulted in the curve as per figure 3.1 and illustrates the typical conveyor profile.

It is evident that the further the material is carried or conveyed the more work is required and hence more absorbed power is used. It can also be seen that the most power is used during cells 15 and 16.

### 3.2.3 Pump profile

As seen from the load list in table 3.1, there are several different pumps contributing to the system or power demand, but all of them follow more or less the same profile. Using the consultants listed 3.2.1 with again special reference to Malan (Oct 2011) and SAPMA (2002, 31 – 66), these profiles were determined by the head pressure of the delivery end of the nozzles. The key variables used were:

- Frictions;
- Distance;
- Pressure; and
- Fluid density.

[3]

These were entered into the formula as below:

$$P = \rho g Q H$$

Or

$$\text{Power (W)} = \text{Density (kg/m}^3\text{)} \times \text{Gravity (9.81 kgm/s}^2\text{)} \times \text{Capacity (m}^3\text{/s)} \times \text{Total head (m)}$$

Total head depends on static head (effective the height of which the fluid is to be lifted), and dynamic head (friction from piping, fittings). Again, the power is a function of the distance, density and amount of liquid the pumps have to move.

From the formula the following series for  $y_n$  have been developed and will be used on all the pumps as a blueprint;

$$y_n = \{25\%, 30\%, 35\%, 40\%, 45\%, 50\%, 55\%, 60\%, 65\%, 70\%, 75\%, 80\%, 85\%, 90\%, 100\%, \dots$$

$$\dots 100\%, 90\%, 85\%, 80\%, 75\%, 70\%, 65\%, 60\%, 55\%, 50\%, 45\%, 40\%, 35\%, 30\%, 25\%\}$$

Again, figure 3.1 plots the curve for the  $y_n$  series.

These two typical profiles,  $x_n$  and  $y_n$  were used as basis for populating the overall pad profile table. The profile table is basically the load list extended to represent the loads over the length of the pad and can be seen in Appendix A, A2.

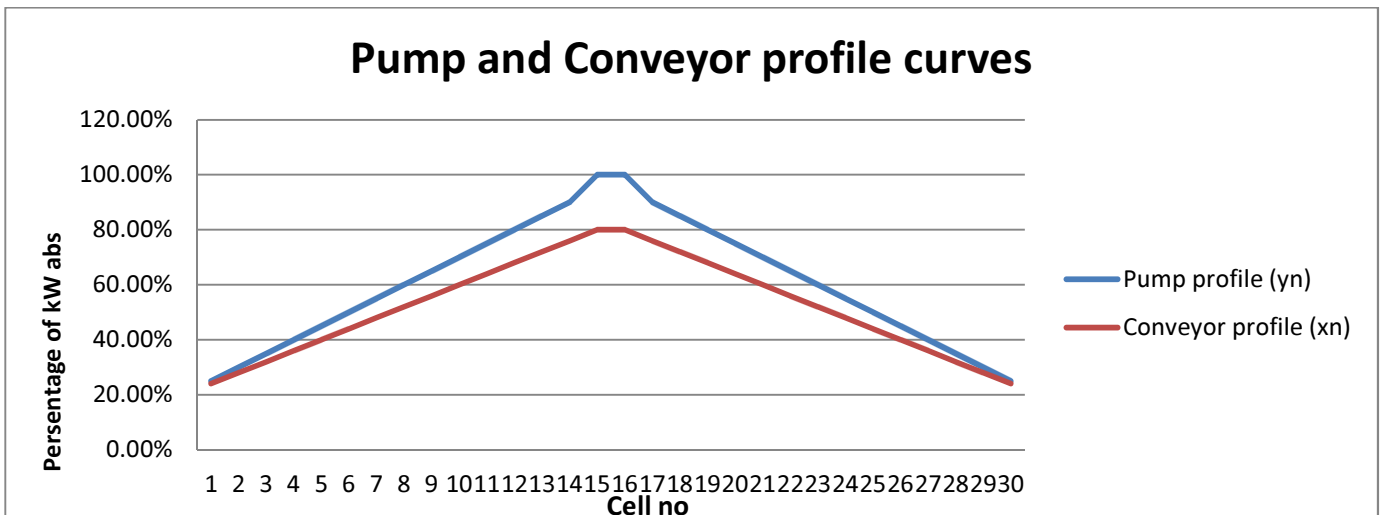

Figure 3.1: A plot of the pump and conveyor profiles illustrating the power requirement over the race track

After the profiles and load list was determined and considering that one process step can occupy more than one cell (see section 2.5.2), formula one was expanded further:

$$P_n(kW) = \sum avg[((processk + n) \times pf_{k+n})]$$

Or;

$$P_n(kW) = Reclaiming + (Waste\ conv. \times x_n) + (Rinsing \times y_n) + avg(Barren \times y_n) \\ + avg(ILS \times y_n) + avg(PLS \times y_n) + avg(Wash2 \times y_n) + avg(Wash1 \times y_n) \\ + (COFC \times x_n) + Stacking$$

An average is used on a process occupying multiple cells. This represents the main pipe delivering the process to the middle cell and then connected over the spread with a smaller piping system. Replacing the description of the loads with its kilowatts and positioning, the formula that will represent the model is produced. [4]

$$P_n(kW) = 2025 + (1682x_n) + 618y_{n+3} + \frac{(1847y_{n+6,7,8,9 \& 10})}{5} + \frac{(1847y_{n+11,12,13,14 \& 15})}{5} + \\ \frac{(581y_{n+16,17,18,19 \& 20})}{5} + \frac{(863y_{n+21 \& 22})}{2} + \frac{(863y_{n+23, \& 24})}{2} + 3352 x_{n+25} + 1992$$

Notes:

- As  $y_n$  and  $x_n$  is applied over the pad, it might want to roll over (go to 31) once process  $k$  is near the end and because there are only 30 cells. To compensate for this if  $n + k > 30$  it should read  $n+k-30$ , but an easier method was used.  $y_n$  and  $x_n$  is extended by repeating itself, i.e.  $y_{31} = y_1$  and similarly for  $x_{31}$  etc.
- $n$  is the step in which the entire process finds itself, i.e. step one to thirty.  $n$  is the position (cell) in relation to the stacker and therefore  $n+3$  means three cell on from  $n$ , i.e. three cells forward in respect with the stacker. For example: if  $n = 4$  it means that the reclaimer is on the fourth cell and the last rinse cycle will be on the 7 cell, etc. To extend this explanation, please see the positioning system as below.
- Positioning:
  - $n$  = the positioning from where the waste conveyor receives the waste from the stacker.

If this is used then the rest of the process are positioned

- $k = 3$  is Rinsing
- $k = 6$  is Barren
- $k = 11$  is ILS
- $k = 16$  is PLS
- $k = 20$  is Wash 2

- k = 23 is Wash 1
- k = 25 is COFC

Using the formula obtained, table 3.2 was populated with the demand side power requirements (a more illustrative spreadsheet can be seen in Appendix A, A1 which was used to apply the formula and serves as a rather good graphical representation of the total overall 300 day process):

Cell	$P_{\text{demand}}$ (Rounded up) in MW
1	10.141
2	10.193
3	10.220
4	10.198
5	10.129
6	10.177
7	10.312
8	10.433
9	10.559
10	10.685
11	10.802
12	10.908
13	11.000
14	11.061
15	11.118
16	11.134
17	11.095
18	11.080
19	11.102
20	11.161
21	11.123
22	11.009
23	10.911
24	10.777
25	10.645
26	10.527
27	10.410
28	10.306
29	10.230
30	10.158

**Table 3.2:** A breakdown as calculated by the formula for each cell position's power requirements

In the next chapter the results of interest are verified using a computer software program, E-tap. The load study and load list from this chapter are used to derive a SLD which is then used as input to the program. The result in table 3.2 and results obtained by the program as a load flow analysis are compared and discussed. In chapter five more statistical information is derived from the results of this chapter and the next chapter which are also presented and discussed. This information can be used in a DSM study.

The final step, which is not part of the scope of this investigation and will be done by the client, is to calibrate the model with the actual plant once it is built and commissioned. According to McGhee (Oct 2011), all MCC incomers will have energy meters installed as part of an energy management system. Each of these MCC energy meters will represent a process unit and subsequently a process in the OOHL. The main plant feeders, supplying the Nampower electricity feed will also have energy meters which will measure, store and report on a hourly, daily and monthly basis on the power consumption. These actual values captured by the meters will then be used to calibrate and validate the model.

## **CHAPTER 4 MODEL VERIFICATION**

### **4.1 Introduction**

The next step in the investigation was to verify the results of specific points (or steps) of interest as listed in table 4.2 and discussed below. E-tap version 7.0.0 was used. As per Boatke (Feb 2011) E-tap only simulate a specific scenario when using the load flow analysis tool. The OOHL model is designed in discrete steps. Each such step constitutes for an operating scenario which can thus be simulated using E-tap. It follows that using E-tap without a comprehensive OOHL model developed beforehand is cumbersome.

According to Chitongo (Aug 2010) the following were considered as points of interests:

- The power peaks, i.e. minimum and maximum points,
- The mean,
- Total absorbed power.

The E-tap program will verify if the model's results is within certain limits, giving an indication that the calculation was performed correctly.

### **4.2 Method**

A Single Line Diagram (SLD) as per figure 4.1 was created and used as basis for this model. Composite networks were used to reduce the information on the main page or to un-clutter it. The composite networks represent, in this SLD, the Motor Control Centres or MCCs. The composite networks or MCCs can be seen in figure 4.2. Each MCC represents a process step and it's loads.

In order to simulate the positions of interest a revision was created for each position. Revisions use the "frame" or base SLD which include the positioning and sizing, but allow you to change the parameters such

as diversity- and utilization factor. The diversity factor represents the profile factor and the utilized factor represents the absorbed power. The utility factor is 0.72 for all the motors. For each step of interest the diversity factor and cell position per process is listed in Table 4.1 (with respect to where the reclaimer is)

The main difference between the results of the software program and the manual calculation was that it is difficult to simulate the average for a process over its entire 5 or 2 cell footprint. So the best position that could represent the average was chosen and used.

	MIN (Cell5)	MAX (Cell 20)	MEDIAN (Cell10)
COFC Conveyor	30 & 24%	15 & 80%	5 & 40%
Reclaim conveyor	5 & 40%	20 & 64%	10 & 60%
Barren	11 & 75%	28 & 35%	17 & 90%
ILS	17 & 90%	3 & 30%	21 & 70%
PLS	21 & 70%	8 & 60%	26 & 45%
Wash 1	29 & 30%	13 & 85%	2 & 30%
Wash 2	25 & 50%	11 & 75%	30 & 25%
Rinse	8 & 60%	23 & 60%	13 & 85%

**Table 4.1:** The position and profile factor used for each process in the simulations.

The SLD contains the following:

- Nampower power supply; 33 kV,
- main 33 kV and 11 kV distribution boards,
- transformers,
- Busses,
- pump section (Ponds) as MCCs,
- the conveyors as single load MCCs,
- and stacker/reclaimer section as static loads.

Figure 4.3 and 4.4 indicates how each component or equipment's data is change to simulate its behavior as per its profile factor and absorbed power.

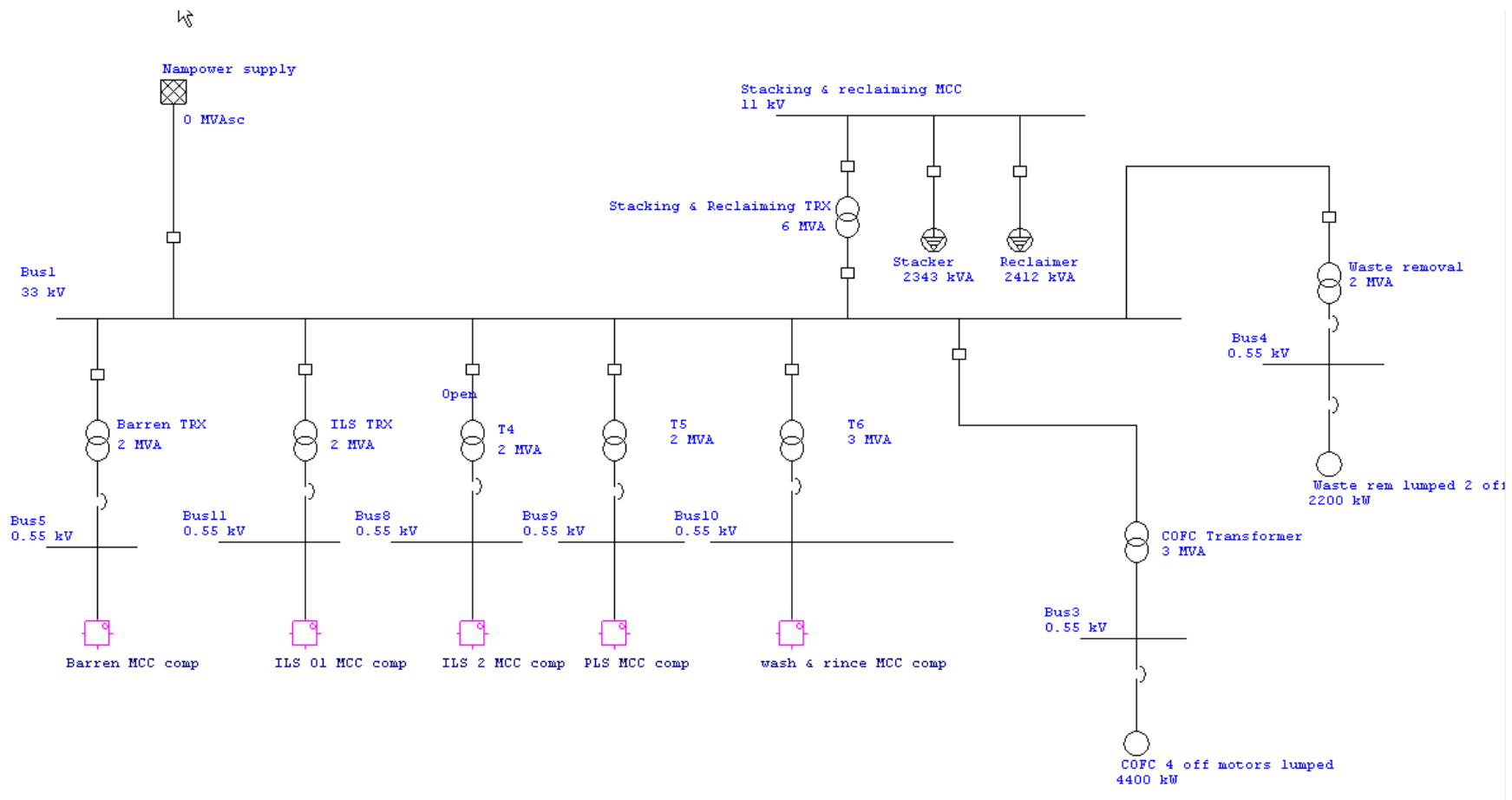

Figure 4.1: The base SLD

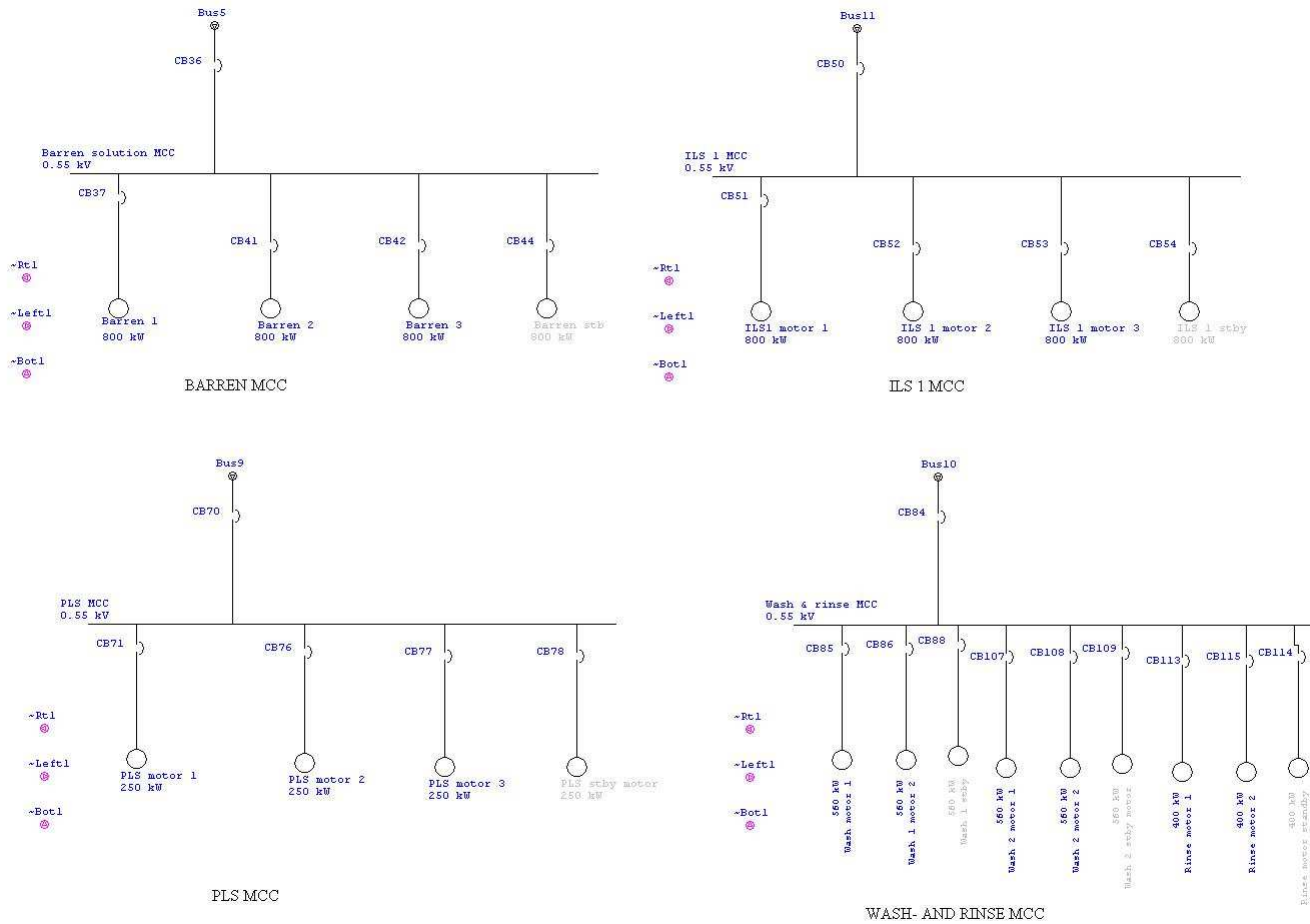
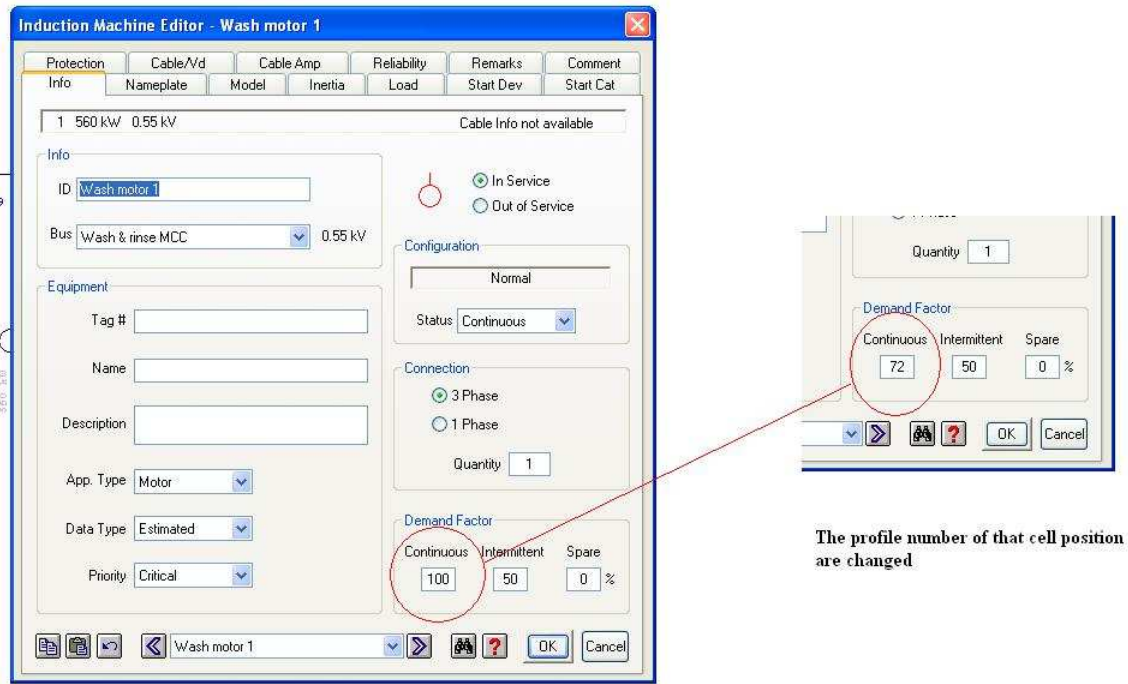

Figure 4.2: The composite networks representing the processes steps (Motor Control Centers)



The profile number of that cell position are changed

Figure 4.3: Changing profile factor

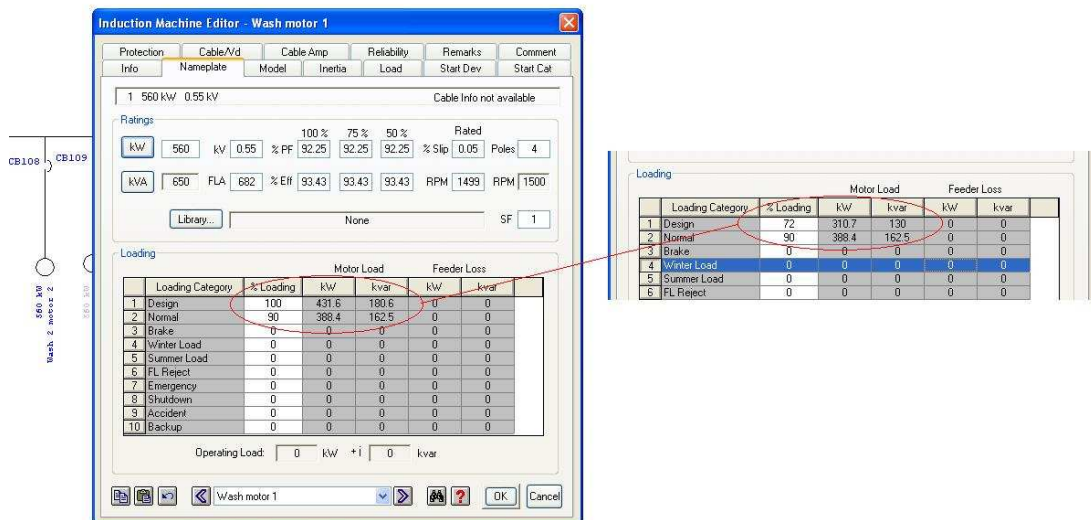
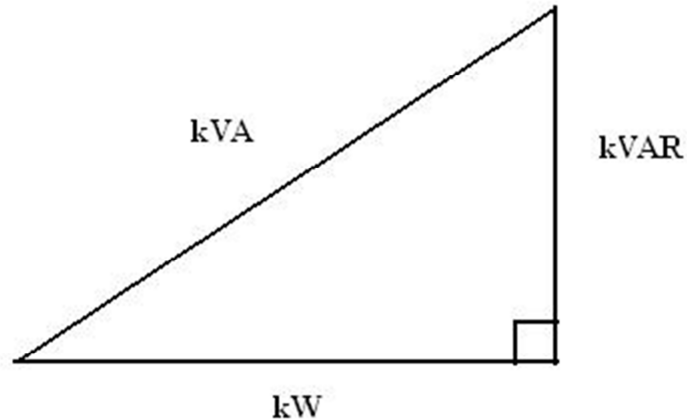

Figure 4.4: Changing the absorbed power.

The simulation uses a load flow simulation that can be chosen to display the real power (kVA) rating, current rating (A) or a combination of real power (kW) and reactive power (kVAR) rating at points of interest. As this investigation is interested in the kilowatts used (kW), the kW and KVAr display was used.

Basic Electrical engineer and Pythagoras indicate that:



$$\text{kW}^2 + \text{kVAR}^2 = \text{kVA}^2$$

or could be represented as;

$$\text{kW} + j (\text{kVAR}) \text{ kVA}$$

The author knows that to some readers the information above might be trivial, but it is presented as a reminder of power relationships. Later, in chapter 5 this will be used to derive the power factor (pf).

Running the simulation on the base SLD the following result were produced (refer to Figure 4.6.) and added to table 4.2. In the green circle the demand power used by the plant at the point of connection can be seen. Also the reactive power is presented.

$$15\ 819 + j (8\ 366) \text{ kVA}$$

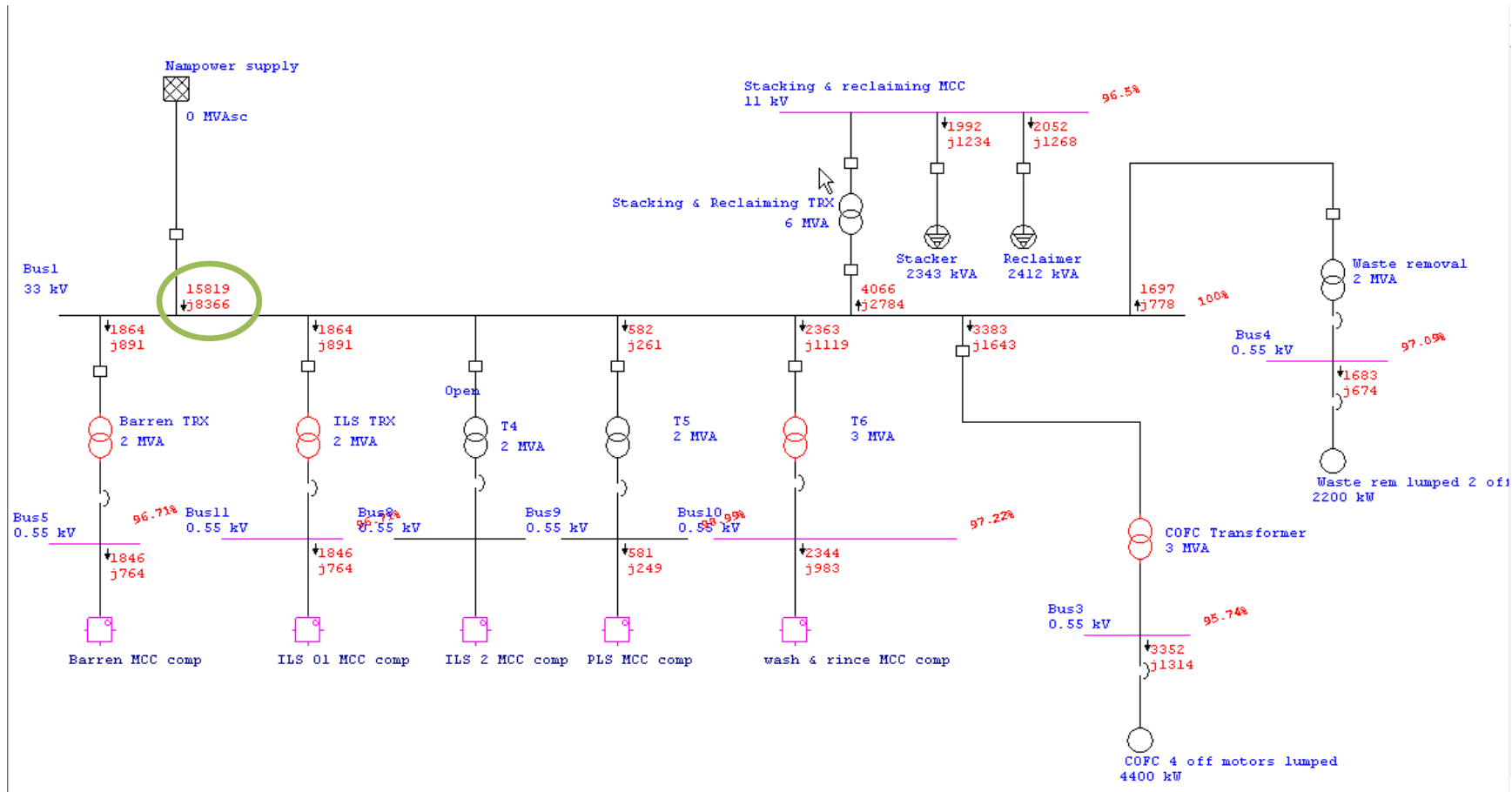

Figure 4.5: An illustration of a load flow analysis result. This particular one indicates the absorbed power.

Now that the base SLD was run on the load flow analysis tool, basically represented the  $P_{abs}$ , the other points of interest can be verified. In table 4.1, a list of each cell or scenario's profile parameters can be seen. These have been entered as per figure 4.3 and 4.4, pg. 48. The table below shows the results.

Cell	$P_{demand}$ (Rounded up) in MW
5 (MIN)	10.089
10 (Median)	10.667
20 (MAX)	11.164
Absorbed kW	15.919

**Table 4.2:** The simulated values for the steps of interest.

### 4.3 Comparing the results

In table 4.3 the results from the formula are compared with the results from the load flow simulation. The cell load peak (max and min) value and the cell load mean value (median) produce a percentage difference of less than 1%. This is a good indication that the formula is accurate and can be used for an OOHLP DSM. The absorbed power simulation differs from the formula by 1.4%. This can be contributed to the losses in the reticulation system.

Even more losses can be expected when drives such as Variable Frequency Drives (VFDs) are introduced to control the flow rates at which the fluids are pumped. These system losses (electrical reticulation losses and drive losses) will increase the demand, but at least this increase will more or less be the same for all 30 steps. A typical value of between 400kW and 600kW can be expected for the system losses as the 224kW from table 4.3 is contributed by the transformers. For VFDs a rule of thumb is to use between 2.5% and 3% of the nameplate rating to calculate losses (McGhee, Oct 2011). 3% of 800kW, the worst case is 24kW. If there are 13 VFDs this leads to 312 kW. The total will then be 536 kW. Designs will minimise  $I^2R$  losses in cable and overhead lines (OHLs).

As mentioned earlier, the difference is also due to process average consumption. Let's use the Barren solution as example. The process on any given time covers five cells. The supply pipes will be connected to the cell in the middle of the five and the spray system will be connected to cover all five. The manual model

calculates this as the average of the five cells used, but the E-tap model cannot do this. So the middle position was used or the best alternative.

With the results verified and the model proven accurate the next chapter analyses these results and discusses this with respect to the OOLHP application.

<b>Cell</b>	<b>Matrix results in MW</b>	<b>E-tap results in MW</b>	<b>Difference in kW</b>	<b>Percentage difference</b>
5 (MIN)	10,139	10.089	50kW	0.4%
10 (Median)	10.685	10.667	18kW	0.1%
20 (MAX)	11,161	11.164	3kW	0.02%
Absorbed kW	15,695	15.919	224kW	1.4%

**Table 4.3:** Comparing the models results with that of the software simulation package for the points of interest.

## **CHAPTER 5    DUSCUSSION OF RESULTS**

### **5.1        Introduction**

In this chapter the result from chapter three and four are analysed and discussed. The statistical information typically required for the DSM is presented. The model results are compared to typical design checks and calculations. A quick calculation is done to see what the power requirements for the services will be and the effect thereof on the demand side consumption.

### **5.2        Analysing the results**

Plotting the results of table 3.2 obtained from the model the following load shape is obtained. See p31.

Using the load shape and the data presented in table 5.1, the following statistical information can be put forward:

Maximum demand:	11.161 MW
Minimum demand:	10.139 MW
Stacking position during maximum demand:	Cell 20
Stacking position during minimum demand:	Cell 5
Average consumption:	10.654 MW
Median:	10.665 MW
Installed kW (from load list in chapter 3):	19.8 MW
Total absorbed kW (from load list in chapter 3):	15.7 MW

*(continued on the next page)*

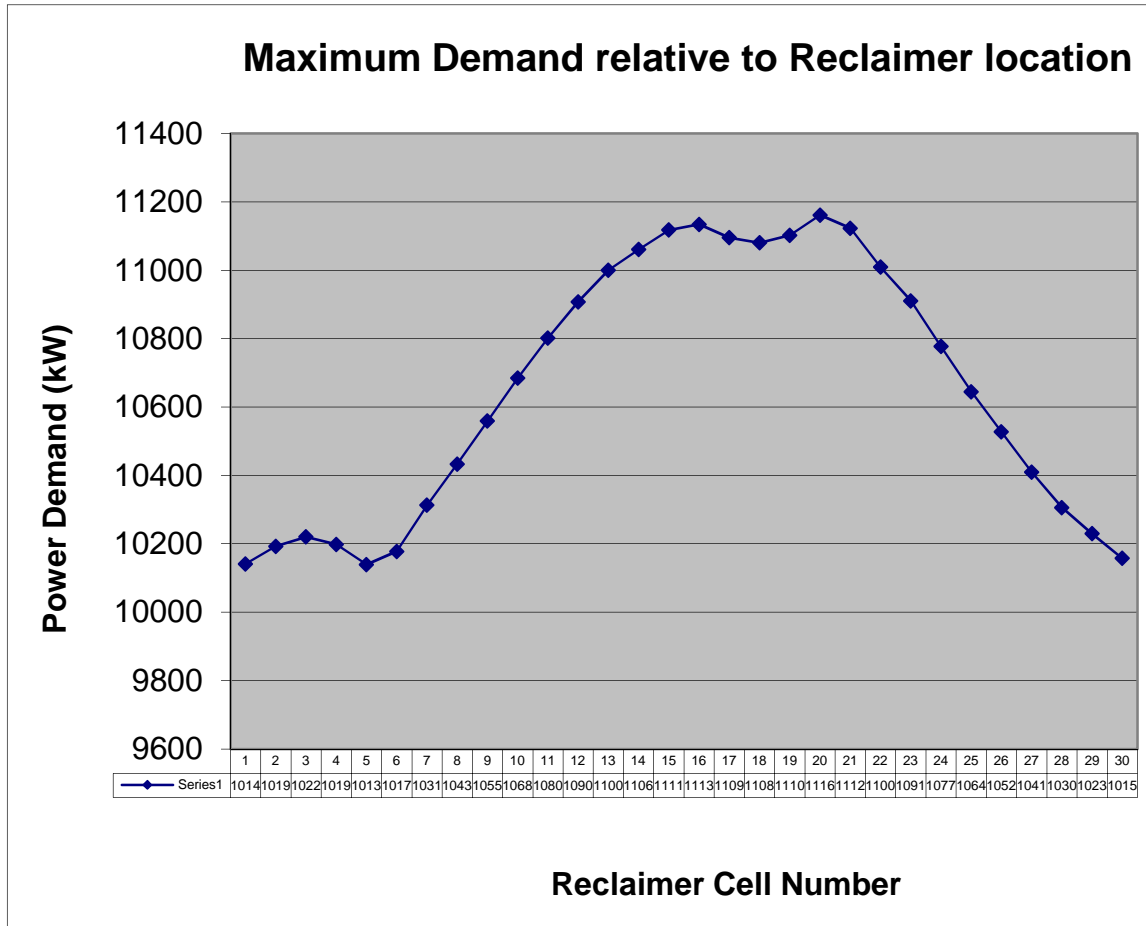

Figure 5.1: The Maxi OOHLP load shape.

Diversity factor (at max consumption):

$$\text{Divf} = \frac{11.161 \text{ MW}}{19.8 \text{ MW}} * 100$$

$$= 56.36 \%$$

Deviations up and down:

$$+ 507 \text{ kW}$$

$$- 515 \text{ kW}$$

Reactive power:

$$8336 \text{ kVAr}$$

Power factor ( $pf$ ):

$$S^2 = 15.7^2 + 8.34^2$$

$$S = 17.8$$

$$pf = \frac{P}{S}$$

$$pf = \frac{15.7}{17.8}$$

$$= 0.88$$

### 5.3 Discussing the results

With no information available to compare the results with, the following were considered:

Usually the pad diversity factor would have been taken as either 0.9 or 0.7 depending on how conservative the engineer is according to McGhee (2011). The conventional approach will be to calculate the absorbed power as:

$$\begin{aligned}
 P_{abs} &= P_{inst} \times MSF \times df && [5] \\
 &= 19.8 \times 0.8 \times 0.7 \\
 &= 11.8 \text{ MW}
 \end{aligned}$$

The maximum demand was calculated with the use of the model as 11.161 MW. This is close to the “quick check” or the conventional method.

That being said, the base line demand for the pad also needs to be included. This is non-process related power consumed and can be seen as services. Although this exercise is not part of this dissertation’s scope or objectives it is discussed next to provide the reader or user with a more comprehensive discussion.

Table 5.1 is a summary of the base power. This is a quick assessment done by McGhee (2011) and the author.

Load description	Estimated kW	Comments
Losses (Load varies)	600	Reticulation, transformers (TRX), cables, drives and converters.
Small power and lighting (SP&L) (Load varies)	228	3 substations with 200 kVA SL&P TRXs. 200 kVA x 0.8pf = 160 kW 160 kW x 0.8 safety margin = 128 kW 128 kW x 0.6 utility factor = 76 kW 3 times 76 kW = 228 kW
Substation air-conditioning units (static/continuous load)	104	3 x 2 (two/substation) x 60 000 BTU units 1 BTU = 0.000293 kWh If it is assumed most of the VFD heat is removed

		with ducts from the substations.
Emergency power (Load Varies)	22	lighting & intelligent relays 3 times 20 kVA Uninterruptable Power Supplies (UPSs) 20 kVA x 0.8pf = 16 kW 16 kW x 0.8 safety margin = 12.8 kW 12.8 kW x 0.6 utility factor = 7.6 kW 3 times 7.6 kW = 22.8
Total	954	+/- 1 MW

**Table 5.1:** A quick estimation made to quantify the service loads for the OOHLP (Nel and Mcghee (2011))

From the results of table 5.1, a lump sum of +/- 1000 kW (or one MW) can be added to each step of the manual model in chapter three to compensate for the services and losses. The load shape will affectively stay the same shape/curve but will shift by 1 MW on the y-axis. This can be seen as a more accurate representation of the actual power consumed.

Another interesting observation is that when the model as in the spreadsheet of appendix A, A1 is examined, it seems that the peaks are determined by the position of the stacker. When the stacker system is at the furthest point, cell 15 the power demand is at its highest and when the stacker is on cell 20, closest to the material source, the power demand is at the lowest. This effectively means that the COFC consumes the most power.

## 5.4 Conclusion

With the load shape obtained from the model and the information of section 5.2 and 5.3 derived from the load shape others, such as the Trekkopje Maxi client can use this to complete the DSM process. The next chapter concludes on this investigation and discusses some recommendation as DSM remedies for an OOHLP.

## **CHAPTER 6 CONCLUSION**

### **6.1 Introduction**

In this chapter a conclusion is given on how this dissertation developed a demand side management model for an on heap leach pad. In the following section some demand side management implementations and techniques are recommended and in the last section a discussion on the DSM study and the impact thereof on the EPCM engineering domain are provided.

To quickly recap (before the conclusion is given); in order to investigate the power requirements of an OOHL and determine the load shape (as part of a DSM process) the following steps were taken;

- Investigate and design a usable OOHL. This was accomplished by using the work done by the Bateman team for the Trekkopje Maxi project.
- Investigate and research similar studies done on other application in order to obtain information or experience to apply.
- Investigating and understanding the process and its equipment and operations to obtain a load shape
- Derive a mathematical model using both a formula and spreadsheet. The spreadsheet as seen in Appendix B not only calculated the results, but also served well as a graphical representation.
- Verifying the results of interest with a software package E-tap.
- Obtaining statistical information from the load shape.

### **6.2 Conclusion**

As a result of the research problem (see section 1.1) and the research objectives (see section 1.2) and how this dissertation resolved and achieved these, the following two figures (6.1 and 6.2) are presented. These figures are provided as the discussion for the conclusion on the methodology selected (and used) by this dissertation to provide a model. It also illustrates how the model, in the form of a load study and formula, can be used as

part of a DSM study on an OOHL. Figure 6.1 illustrates how the DSM *process* was applied to the OOHL by this dissertation. Figure 6.2 illustrates how this dissertation used a DSM *study* to achieve the objectives (as per section 1.2).

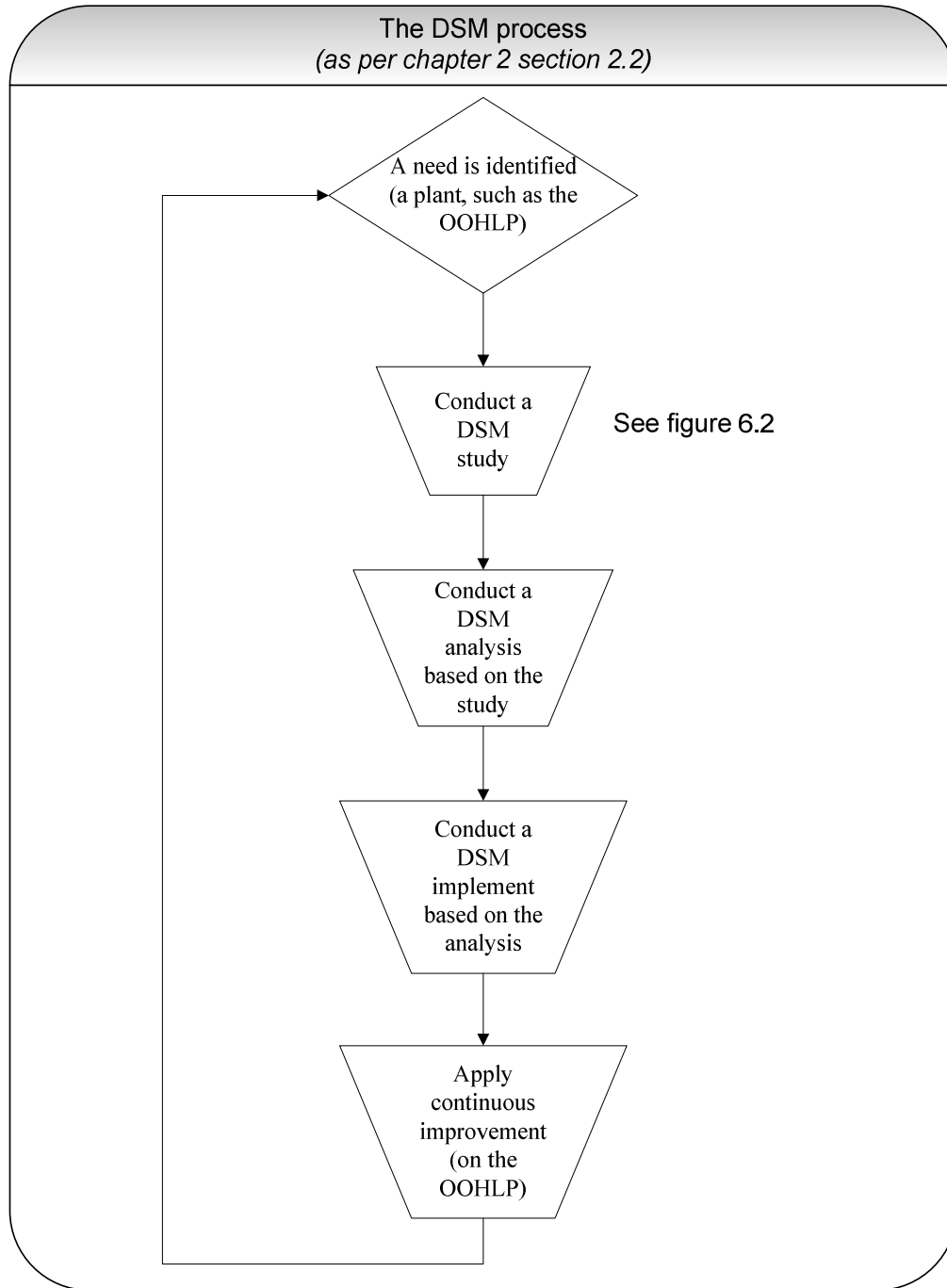

**Figure 6.1:** Illustrating the DSM process as set out by chapter two (figure created by the author).

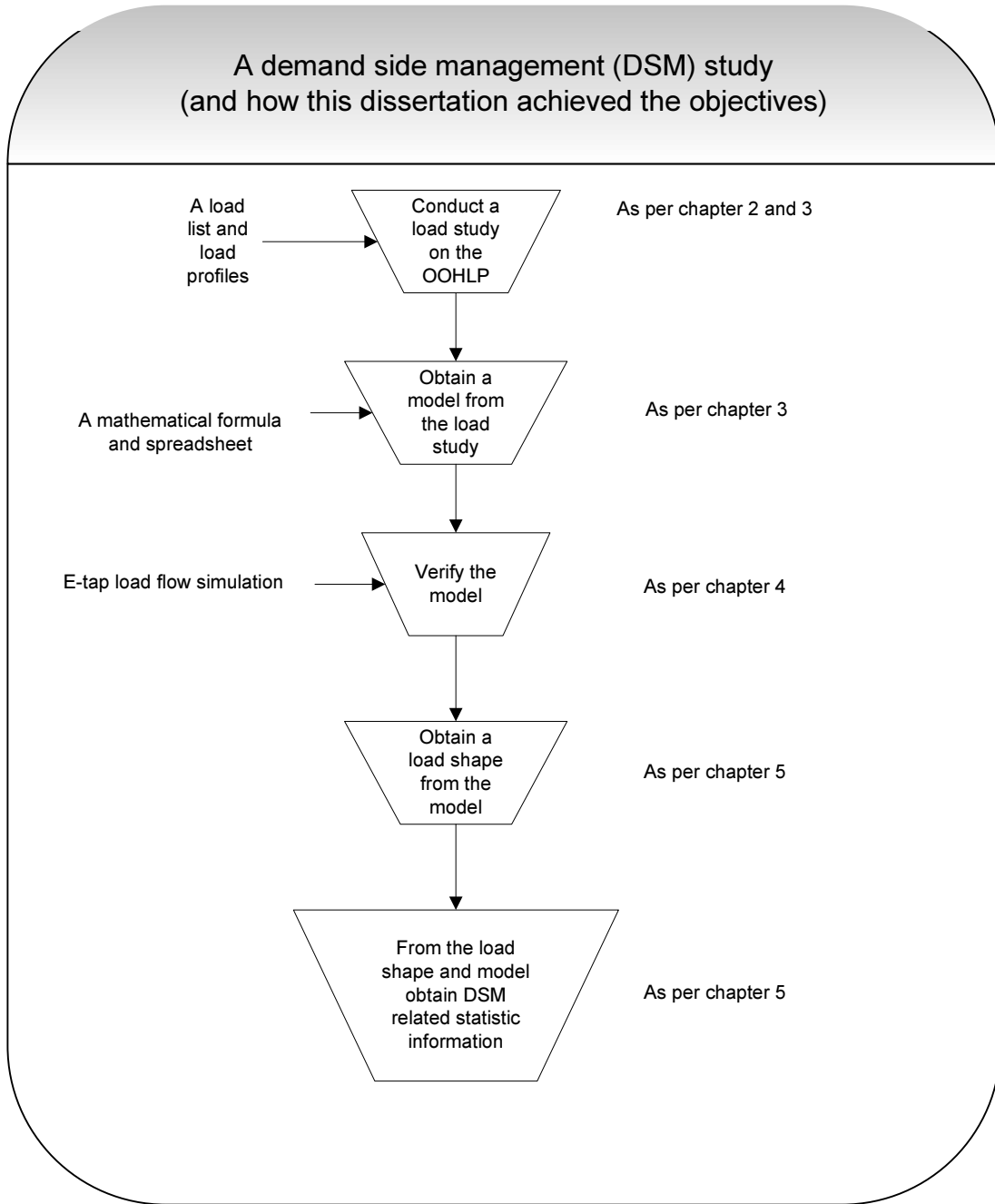

**Figure 6.2:** Illustrating a DSM study as followed by this dissertation (figure created by the author).

From the above it is evident that:

A method to develop a model as part of an overall DSM process to predict the energy demand of a greenfield OOHL P is now available to consumers. Consumers, such as Trekkopje Maxi can apply this same methodology to study and analyse an OOHL P's demand and implement measures to increase the efficiency of which the OOHL P operates. If applied correctly and using implementations such as in the next section, savings can be made on both capital- and operation expenditure.

In the next section some DSM implementations as remedies to increase the electrical demand efficiency are discussed. These implementations are recommended as they are considered the most applicable to the OOHL P process given the information obtained from the model.

### **6.3 DSM recommendation**

With the load shape obtained and verified prospective or future users can now investigate DSM implementations on the OOHL P. The following are recommended:

- Tariff synchronizations
- Load shape manipulations
- Reticulation equipment/component sizing
- Optimal power factor correction or PFC

These remedies are considered the most applicable and will add the most value to the OOHL P process given the information obtained from the model. Other options, such as using more efficient components/loads, minimising losses, etc., should not be excluded. These should be applied / implemented in parallel or as part of the solutions below.

#### **6.3.1 Tariff synchronization**

The bottom line for the customer is to save money on the electrical bill. The amount of money spent on power is determined by the time you use it and the tariff at the time, which is based on two legs. One is the connected power peak and the other the seasonal power tariff. In order to calculate monthly bills, the peak

kVA demand and the number of kVA used as well as the MWh needs to be known. The apparent power also plays a role, but this is usually limited by your level of PFC (see section 6.3.4).

With the model, i.e. the load shape and load list, together with the yearly and daily tariff costs, one can project the power cost over a predefined period. Normally the winter periods, May to July, is the most costly and the remaining months vary.

Plotting the tariffs over a period of five years, and then interposing the pads demand graph, extrapolating it for five years, one can see in which seasons the power peaks will be and which loads consumes the most energy during that time. This allows the user to plan in advance when and how to control the demand. This can be done by manipulating the load shape. The next section explains more on the load shape manipulation.

### **6.3.2 Load shape manipulations to exploit supplier low end tariffs**

As part of the DSM implementation and execution phase the load shape can be manipulated with the following exercises:

- **Load shifting (or load management):**  
When the plant OOHLPP is operating on the peak demand, other areas of consumption can be trimmed or decreased if possible, i.e. these processes can operate during the lower demand peaks (see the next point). This works well with batch process. It is important to note that when implementing load shifting of load management the service(s) provided must not be affected.
- **Valley filling:**  
When the OOHLPP approaches the lower end of its power demand, other process can be started to add redundancy. A good example is additional buffers such as run of mine stockpiles can be filled by increasing the through put through crushers, screens and conveyors.
- **Peak clipping:**  
Applying better technology or smarter control to the process during peak periods can to reduce the electrical demand. Let's use the barren solution as example. Three pumps are used in this process, but not all three needs to run simultaneously. Using the load profile for the pumps, for power requirement less than 67% only two pumps are necessary. Operating only two pumps will require it to "work" closer to their area of good efficiency rather than three that will operate at a lower power factor and lower efficiency.

These three techniques are closely associated. It follows that if one is applied the other is necessary and is automatically introduced (as a reaction). With these the off-peak periods can be exploited and additional capacity can be introduced, i.e. when the power requirements in the off-peak periods are low – other process, like filling run of mine piles or other batch process, can be increased as far as possible.

### 6.3.3 Reticulation equipment/component sizing

Every greenfield customer needs to apply for power allocation with the energy supplier. For this, the consumer needs to specify the exact amount of power to be utilized. Without the exact figures from this study the pads contribution to the overall power requirements would have thought to be:

$$P_{demand} = f_{utility} \times P_{abs} \quad [6]$$

Where;

$P_{demand}$  is the power required

$P_{abs}$  is the actual power consumed of all the drives

$f_{utility}$  is the utility factor

The utility factor can basically be seen as how all the loads are utilized together. As an example of this; if four lights are installed in a house of 100W each, but only two are used at any time then your  $f_{utility} = 0.5$  and therefore your  $P_{demand}$  will be  $4 \times 100 \times 0.5 = 200W$  as opposed to the installed kW of 400W. Usually contemporary demand calculation will be with a  $f_{utility}$  of 0.9 or 0.7 and  $P_{demand}$  would look like this;

$$\begin{aligned} P_{demand} &= 0.9 \times 19.8 \text{ MW} \\ &= 17.82 \text{ MW} \end{aligned}$$

or

$$\begin{aligned} P_{demand} &= 0.7 \times 19.8 \text{ MW} \\ &= 13.86 \text{ MW} \end{aligned}$$

This means that the user, in the past would have applied for 17.8 or 13.86 MW plus the rest of the plant base demand. With the model of this investigation it is now known that the  $f_{utility}$  is 0.56. Therefore:

$$P_{demand} = 0.56 \times 19.8 \text{ MW}$$

$$\begin{aligned} &= 11.1MW \\ \text{difference of } &\frac{(19.8 - 11.1)MW}{19.8} \\ &= 44\% \end{aligned}$$

Applying this reduction in the maximum demand figure to the maximum demand tariff charges will lead to significant savings. With a full scale investigation this saving can be determined more accurately. To go one step further, if the customer knows from the results of the model that the maximum demand will only be, about 11 MW and not 20 MW, the overhead lines (OHLs) or medium voltage cables (MV cables) feeding this section of the plant, together with the transformers, isolators, circuit breakers, reclosers, etc, i.e. reticulation equipment can be sized smaller and hence cheaper.

With these savings, equipment with better reliability and better maintainability can be bought, i.e. equipment that needs less maintenance. Or redundant backup systems can strategically be put in place to eliminate downtime.

All of these will save money and one can re-apply these savings. Eventually this can become reiterative. With a formal study the exact effects on availability, reliability and maintainability and later cost savings can be determined.

### **6.3.4 Continuous power factor correction**

The power factor correction (PFC) can be designed more effectively and this is usually one of the main outcomes for a DSM on industrial and mining plants. Although the load study or load list only looks at the kW used, it can include for the reactive power using the motor supplier's datasheets. Also, the simulation/verification from the software package gave an effective apparent power (kVAR) value for each cell position.

Again, usually the normal procedure will be to design a PFC and harmonic filtering bank for 96% of the total "absorbed" kVAR, but with a known dynamic reactance changing 30 times in the period several filters can be installed in parallel. These can be switched into the system in predefined steps as designed for, but this off course requires a separate investigation.

The benefits of having PFC are that if the client is billed for the kVA and not only the kW consumed, the PFC will lower the bill and also the system currents are less and therefore cables and other components can be sized accordingly and save money. It also reduces the  $I^2R$  losses

Next, the DSM process is discussed within the boundaries of the EPCM engineering domain and more specifically the importance thereof on greenfield projects.

## 6.4 A final word

With a load shape (which is verified) delivered by this study for the Maxi OOHLP, several value-adding-DSM-outcome-based-studies can be conducted to increase profit margins for a consumer, i.e. the client. These DSM deliverables offers information that can be applied by the client (if he so accepts) to OOHLP in order to increase the plants electrical efficiency. This will translates to savings and also a reduction of the footprint left on natural recourses and the impact on climate change. So what is the value added by obtaining the load shape upfront (before execution and construction)?

- If these DSM strategies (remedies) are implemented into the upfront design of the plant the forecasted savings can be used to buy more efficient equipment. Normally this high efficiency equipment is more expensive and as a tradeoff the clients usually settles for less expensive yet still moderately efficient equipment. They can now motivate to buy more expensive, reliable and efficient equipment. With the increase in efficiency even more money can be saved and then subsequently be spent to enhance the efficiency in other areas (or reapplied in a similar fashion). This can become an iterative process and if the client commits to this, newer and newer possibilities will surface. In the end, it comes down to total cost of ownership where the client will want to tradeoff his capital expenditures versus his operation expenditures.

The client can also include for an increase in process capacity and plant throughput to exploit the off-peak periods (valley filling and load shifting) using the initial project budget. This can be done with redundancy or increase of component sizes.

- Given a more accurate power demand figure the client can approach the utility supplier with more confidence and apply for power without the fear of rejection.
- Even more so, with more accurate figures the client can revisit his budgets allocated to the electrical design during the design phase.

To conclude, there's a very old saying in the EPCM industry and one that Bateman abides to:

*“A change during the design phase is a hell of a lot cheaper than that same change on site”. – Unknown.*

## REFERENCES

APEX FENNER. Updated Feb 2002. The conveyor handbook. Australia.

BLAKE, C. 2010. A meeting held with Trekkopje Maxi project manager. Johannesburg.

BOATKE, I Dr. 2010 and 2011. A telephone conversation with a load flow analysis and E-tap expert Johannesburg.

BOWLIN, M. 1999. <http://www.bp.com/>. Accessed Jun 2011

BUMIGEME. <http://bumigeme.com/Main-Activity-Mine>. Accessed Oct 2011.

BURGESS, L. A copper mining company to watch, A big surprise in the copper market. July 2008. <http://www.wealthdaily.com/articles/copper-mining-company/2059>. Accessed Oct 2011.

BUYS, P. Oct 2011. Telephone conversation with an Eskom Demand Side Management Manager. Johannesburg. (Recorded in notebook.)

CARTER, C. [www.logialscience.com/energy/quotes.html](http://www.logialscience.com/energy/quotes.html). Accessed Feb 2011.

CARTER, C. [www.stthomas.edu/recycle/energy.htm](http://www.stthomas.edu/recycle/energy.htm). Accessed Feb 2011

CHITONGO, A. 2010 and Jun 2011. Verbal communication with the Trekkopje Project Electrical manager. (Recorded in notebook)

CLAASENS, I. 2010 – 2011. Several verbal communication sessions held with a Bateman metallurgic engineer. Notes kept in a notebook. Boksburg.

COTTERRELL, R. 2010. Sulzer segment manager. A telephonic conversation. Johannesburg.

ECB. Namibia, Electrical Control Board. May 2006. Demand Side Management Study for Namibia, EMCON Consulting group in association with Tinda ESI Consultants.

Eskom's Demand Management webpage. [www.eskomidm.co.za](http://www.eskomidm.co.za). Accessed continuously between the period of Jun – Nov 2011.

E-tap programming. [www.etap.com](http://www.etap.com). Accessed continuously between Jan 2011 and Oct 2011.

FLSmidth se webpage (general), <http://www.flsmidth.com>. Last accessed Nov 2011.

FLSmidth website – conveying section. <http://www.flsmidth.com>. Last accessed Nov 2011.

GROBBELAAR, L. Oct 2011. A phone conversation on DSM.

IIEC. International Institute for Energy Conservation, July 2006. Demand Side Management Best Practice Guidebook for pacific island Power Utilities.

[www.sidsnet.org/docshare/other/20070110DSMBestpractices.pdf](http://www.sidsnet.org/docshare/other/20070110DSMBestpractices.pdf). Date of access: Aug. 2011.

IIEC. International Institute for Energy Conservation, [www.iiec.org](http://www.iiec.org). Accessed during the period of Jun – Nov 2011.

JANSEN, M & Taylor A. (Best available date) Jun 2006. A new approach to heap leach modeling and scale-up. For the International Project Development services. [www.altamet.com.au](http://www.altamet.com.au). Accessed Oct 2011. p18.

JORDAAN, N. Nov 2007. New Demand side management opportunities in the precious metals industry. Pretoria: PU. (Thesis – PhD.)

KAPPAS, D. Precious metal heap leach design and practice. [www.kcareno.com](http://www.kcareno.com). Accessed Oct 2011. p25.

KRUSE, D. 2010. Conveyor design report, Maxi (a project specific document). Johannesburg. 97p.

LOWTH, PA. Aug. 2011. Verbal communication with a Demand Side Management expert. Bateman, Boksburg. (Recorded in notebook.)

MALAN, D. Oct 2011. A conversation held with the mechanical package and design engineer for the Trekkopje Maxi project. Email kept. Boksburg.

MCGHEE, D. 2011. M7348 – E831-001 Rev A. Trekkopje Maxi master load list. Filed in livelink.

MCGHEE, D. Oct 2010 and Oct 2011. Lead electrical engineer and principle electrical. Trekkopje Maxi. Johannesburg.

MEL. M7348 - M880 – 001. Rev B. Trekkopje Maxi Mechanical Equipment list. Filed in Livelink.

NEL, L. 2010. M7348-E832-10 to 16 rev. B. MCC load lists for the Trekkopje Maxi project. Filed in livelink.

P&IDs. M7348 – P130. P&IDs. Filed in livelink. Bateman. Boksburg.

PFDs. M7348 – P120. PFDs. Filed in Livelink. Bateman. Boksburg.

PRETORIUS, D. Oct 2010 and Oct 2011. Electrical functional manager. Johannesburg.

REDELINGHUYS, T. 2010 to 2011. Several conversations with the mechanical package and design engineer for the Trekkopje Maxi project. Boksburg.

RPI. <http://www.rpi.edu/dept/chem-eng/Biotech-Environ/LEACH/heap.htm>. Accessed Oct 2011.

RPI. <http://www.rpi.edu/dept/chem-eng/Biotech-Environ/LEACH/leach.htm>. Accessed Oct 2011.

SAPMA (South African Pump Manufacturers Association). 2002. Pumps, principles and practice. Northcliff. 218p.

Sustainable energy regulation and policy making for Africa. Demand side management, Module 14. <http://africa-toolkit.recep.org/modules/Module14.pdf>. Accessed Oct 2011.

SYTSEMA, P. Nov 2008. M7348-2300-001 rev D Approved site conditions. A project document. Johannesburg.

U.S. EPA, United States Environmental Protection Agency. 1994. A technical report on treatment of cyanide heap leaches and tailings. Washington. p48.

VALASIS, J. 2009 – 2011. M7348-E110-001 rev. D. Trekkopje Maxi over all SLD. Filed in Livelink.

VALASIS, J. 2009 – 2011. M7348-E120-001 rev. D. Trekkopje Maxi general layout. Filed in Livelink.

VAN NIEKERK, A. March 2010. A meeting held with the lead mechanical engineer for the Trekkopje Maxi project. Johannesburg.

VAN RENSBURG, JF Dr. Oct 2011. Telephone conversation. Boksburg. (Recorded in notebook)

WESTON, B. 2010 – 2011. Several verbal communication sessions held with a Bateman process engineer. Notes kept in a notebook. Boksburg.



A demand side management study model for an on-off heap leach pad

		1	2	3	4	5	6	7	8	9	10	11	12	13	14	15	16	17	18	19	20	21	22	23	24	25	26	27	28	29	30					
a.	Pump profile (%)	25.00%	30.00%	35.00%	40.00%	45.00%	50.00%	55.00%	60.00%	65.00%	70.00%	75.00%	80.00%	85.00%	90.00%	100.00%	100.00%	90.00%	85.00%	80.00%	75.00%	70.00%	65.00%	60.00%	55.00%	50.00%	45.00%	40.00%	35.00%	30.00%	25.00%					
b.	Conveyor profile (%)	24.00%	28.00%	32.00%	36.00%	40.00%	44.00%	48.00%	52.00%	56.00%	60.00%	64.00%	68.00%	72.00%	76.00%	80.00%	80.00%	76.00%	72.00%	68.00%	64.00%	60.00%	56.00%	52.00%	48.00%	44.00%	40.00%	36.00%	32.00%	28.00%	24.00%					
		Cell no																																		
Description	No. of Drives	Instr. kW	1	2	3	4	5	6	7	8	9	10	11	12	13	14	15	16	17	18	19	20	21	22	23	24	25	26	27	28	29	30				
<b>1</b>	<b>CORRIDOR CONVEYOR</b>																																			
1.1	CENTRAL PCE	4	1100	3352.38	805	939	1073	1207	1341	1475	1609	1743	1877	2011	2146	2280	2414	2548	2682	2682	2548	2414	2280	2146	2011	1877	1743	1609	1475	1341	1207	1073	939	805		
<b>2</b>	<b>SPENT ORE FACILITY</b>																																			
2.1	RECLAIM CON	2	1100	1682.6	404	471	538	606	673	740	808	875	942	1010	1077	1144	1211	1279	1346	1346	1279	1211	1144	1077	1010	942	875	808	740	673	606	538	471	404		
<b>3</b>	<b>HEAP STACKING</b>																																			
3.1	STACKING SYL	24	2767	1992	1992	1992	1992	1992	1992	1992	1992	1992	1992	1992	1992	1992	1992	1992	1992	1992	1992	1992	1992	1992	1992	1992	1992	1992	1992	1992	1992	1992	1992	1992		
<b>4</b>	<b>HEAP LEACH PAD</b>																																			
4.1	WARREN SOLU	3	800	1845.76	461	554	646	738	831	923	1015	1107	1200	1292	1384	1477	1569	1661	1846	1846	1661	1569	1477	1384	1292	1200	1107	1015	923	831	738	646	554	461		
4.2	WARREN SOLU	1	800																																	
4.3	ILSF PUMPS	3	800	1845.76	461	554	646	738	831	923	1015	1107	1200	1292	1384	1477	1569	1661	1846	1846	1661	1569	1477	1384	1292	1200	1107	1015	923	831	738	646	554	461		
4.4	ILSF PUMP - SE	1	300																																	
4.5	ILSF PUMPS L	2	300																																	
4.6	ILSF PUMP - SE	1	300																																	
4.7	PLS PUMPS	3	250	580.583	145	174	203	232	261	290	319	348	377	406	435	464	493	523	591	591	523	493	464	435	406	377	348	319	290	261	232	203	174	145		
4.8	PLS PUMP - SD	1	250																																	
		16		4272.1																																
<b>5</b>	<b>WASHING / FRESH WATER MAKE-UP</b>																																			
5.1	WASH 1 PUMP	2	560	863.106	216	259	302	345	388	432	475	518	561	604	647	690	734	777	863	863	777	734	690	647	604	561	518	475	432	388	345	302	259	216		
5.2	WASH 1 PUMP	1	560																																	
5.3	WASH 2 PUMP	2	560	863.106	216	259	302	345	388	432	475	518	561	604	647	690	734	777	863	863	777	734	690	647	604	561	518	475	432	388	345	302	259	216		
5.4	WASH 2 PUMP	1	560																																	
5.5	RINSE PUMPS	2	400	617.628	154	185	216	247	278	309	340	371	401	432	463	494	525	556	618	618	556	525	494	463	432	401	371	340	309	278	247	216	185	154		
5.6	RINSE PUMPS	1	400																																	
		9		2342.84																																
<b>6</b>	<b>RECLAIMING</b>																																			
6.1	Tot. RECLAIM	23	2850	2052	2052	2052	2052	2052	2052	2052	2052	2052	2052	2052	2052	2052	2052	2052	2052	2052	2052	2052	2052	2052	2052	2052	2052	2052	2052	2052	2052	2052	2052	2052		
	Total dr kW			15695																																
	Total Inst kW			19777																																

A2: The extended load list with the inclusion of the individual load profiles.

## APPENDIX B: E-tap simulations

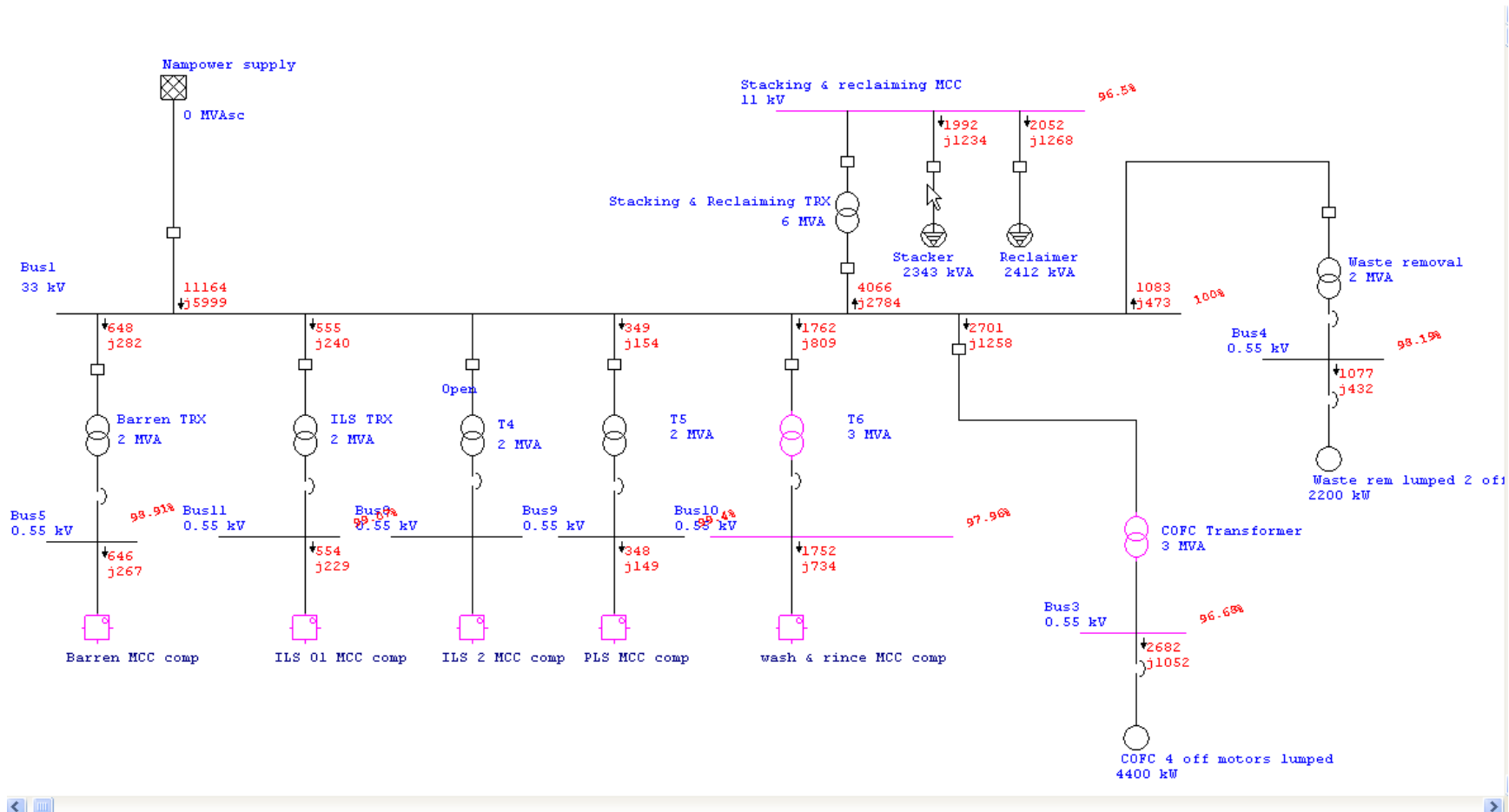

Figure B1: The E-tap simulation for cell 20 which is the maximum demand.

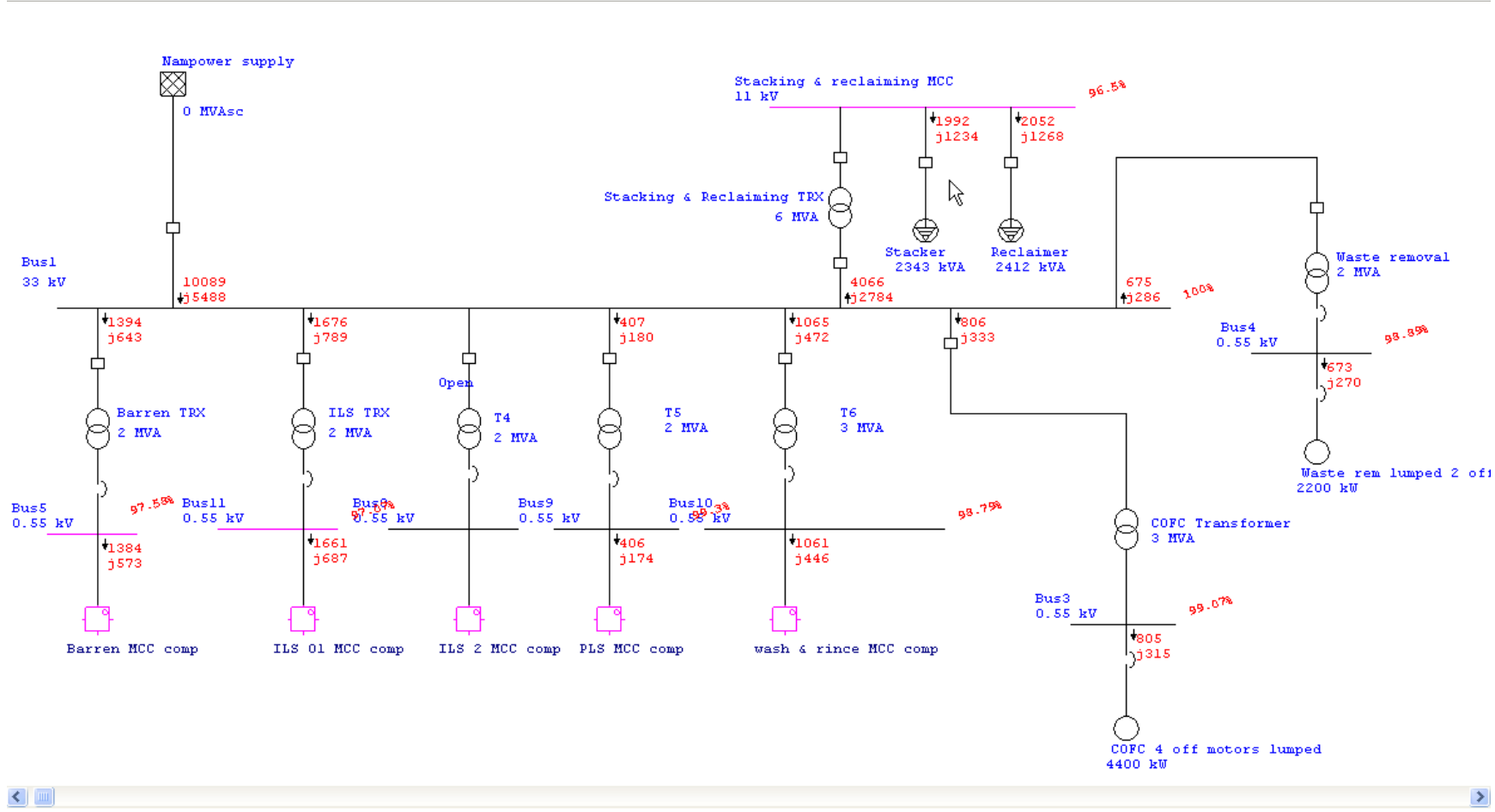

Figure B2: The E-tap simulation for cell 5 which indicates the minimum demand

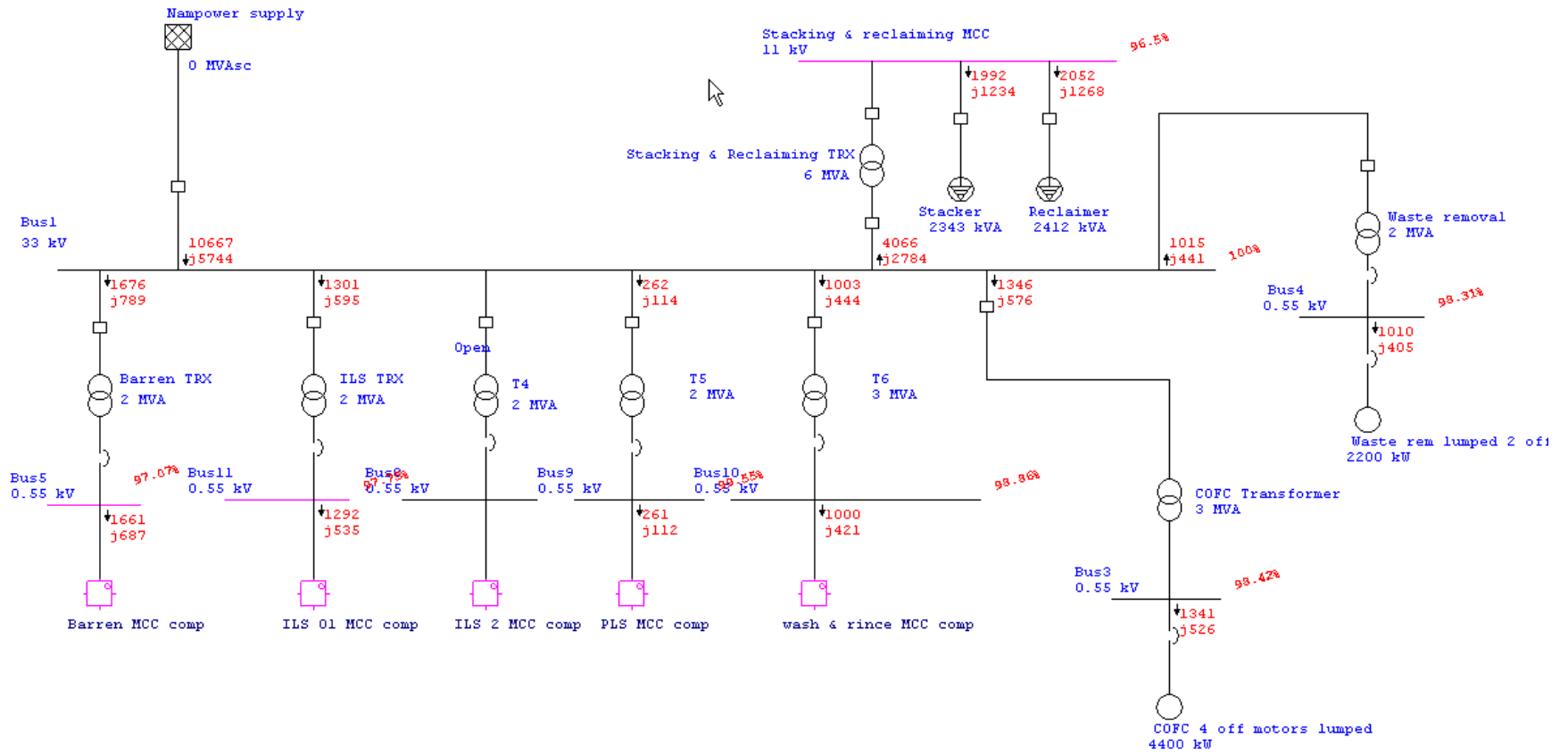
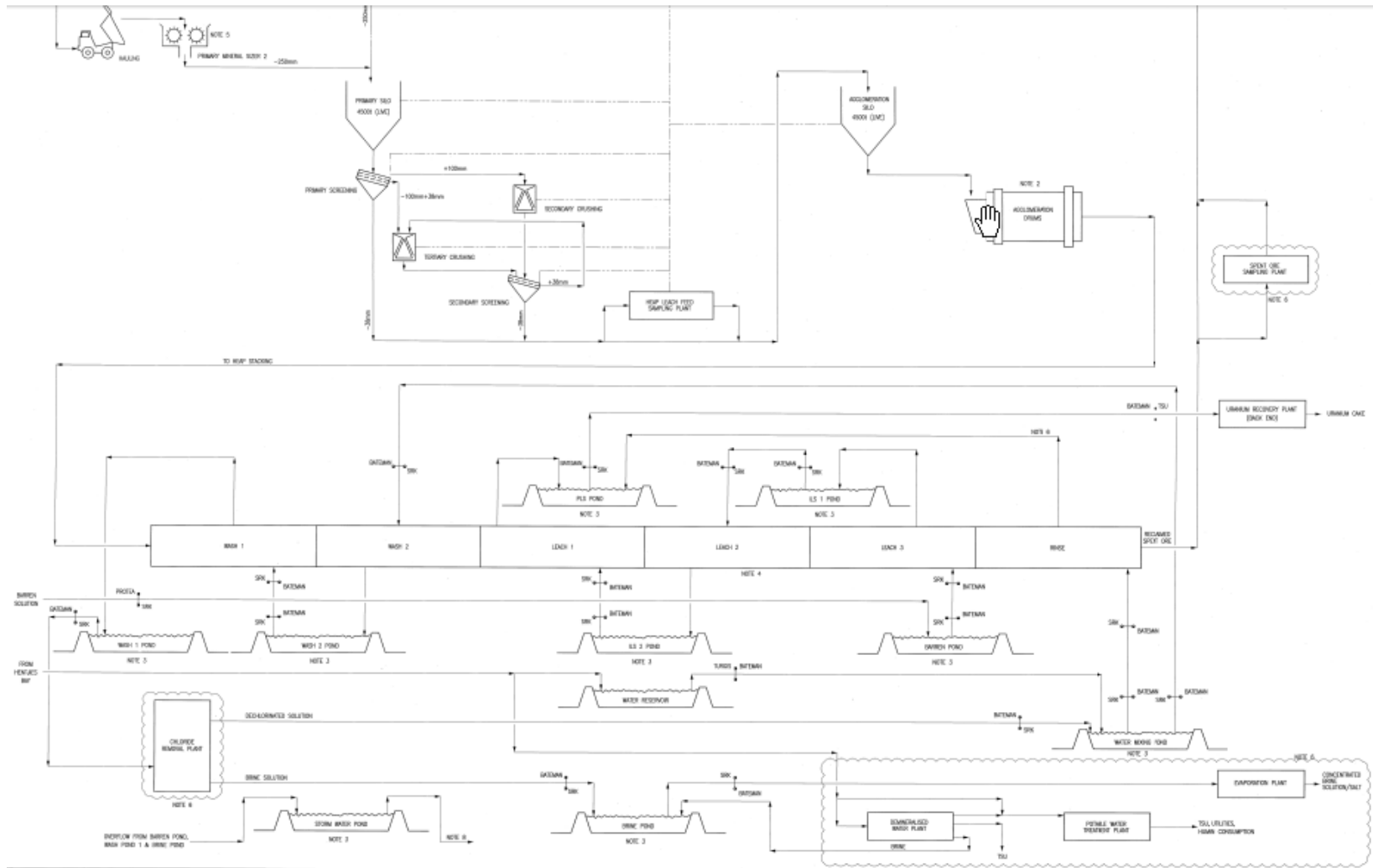

Figure B3: The E-tap simulation for cell 10 which indicates the median demand

### APPENDIX C: The process illustrated as a block flow diagram.



## APPENDIX D: Examples of actual load lists

Below are two load lists created by the author as an example of actual load lists that might be used in a DSM study.

MCC LOAD SCHEDULE										TREKKOPIE MAXI PROJECT													
MCC TAG NUMBER: 36-MCC-001 SERVICE: AREA F01 - HEAP LEACH PAD BRIGGATION MCC01 TYPE: CONTAINERISED MCC (FULLY EQUIPPED) MCC RATING: 32kV, 3 Phase, 3 Wire BUSBAR RATING: 3000A, 50kA LAYOUT DRAWING NUMBER: T.B.A										BATEMAN PROJECT NUMBER: 87348 BATEMAN DOCUMENT NUMBER: 87348-033-013 LOCATION: BOTTOM OFF AND BETWEEN BUS POWER 1 & 2 (1) REMARKS: 1. STARTER PANELS IN EMERGENCY SECTION TO BE PAINTED RED 2. Operating kW Factor = 0.75; Diversity Factor = 1										REV		B	
Rev	PFD DWG No	Equipment No.	Starter Type	Equipment Description	MCC Number	Qty	Rated Output Power (kW/EMC Device)	Number of EMC devices	Total Installed Power (kW rated)	Standby (kW)	Emergency Generator Power (kVA)	Load Capacity Factor	Designed Absorbed Power (kW) (kW rated x LCF)	Power Factor at % Load per EMC Device (Alstom Catalogue)	Efficiency at % load (Alstom Catalogue)	Operational Factor (DV)	Designed Operating Load (kW)	Designed Operating Load (kVA)	Designed Operating Load (kVA)	Typical Schematic Sheet No.	Release/hold		
A		36-IR-1	IR1	INDOMER 3000A	36-MCC-001	1	3000A														H		
A		36-IR-2	ACDP1	AUTO CHANGEOVER	36-MCC-001	1	3000A														H		
A		36-PUMP-01A	FDRV	SARREN SOLUTION PUMP A	36-MCC-001	1	900	1	900		YES	0.3	704.00	0.83	0.96	0.78	572.00	473.00	650.16		H		
A		36-PUMP-01B	FDRV	SARREN SOLUTION PUMP B	36-MCC-001	1	900	1	900		YES	0.3	704.00	0.83	0.96	0.78	572.00	473.00	650.16		H		
A		36-PUMP-02C	FDRV	SARREN SOLUTION PUMP C	36-MCC-001	1	900	1	900		YES	0.3	704.00	0.83	0.96	0.78	572.00	473.00	650.16		H		
A		36-PUMP-03D	FDRV	SARREN SOLUTION PUMP D	36-MCC-001	1	900	1	900	YES	YES	0	0	0.8	0.96	0.00	0.00	0.00		H			
A			CM	CONTROL AND DEVICES CUBICLE	36-MCC-001	1															H		
A			WLD	48KV WELDING SOCKET FEEDER	36-MCC-001	1	8.50		8.50								2.00	0.00	2.36		H		
A			CTN	1100V CONTROL TRANSFORMER WITH EP PROTECTING	36-MCC-001	1	1.00		1.00								1.155	0.00	1.423		H		
A			FDNS	LIGHTING FEEDER AND TRANSFORMER CUBICLE	36-MCC-001	1	2.00	1.00	2.00								1.00	0.00	2.36		H		
<b>TOTALS</b>										<b>10</b>		<b>3,211</b>	<b>800</b>	<b>1,378</b>									
DOL = Direct On Line Non Reversing Starter DOLR = Direct On Line Reversing Starter DOLM = Direct On Line Manual Non Reversing Starter DOLRM = Direct On Line Reversing Manual Starter DOLT = Direct On Line Load Shed Starter DOL2S = Direct On Line 2 speed Starter SD = Soft Starter VFD = Variable Frequency Inverter (VFD installed in the same room) SO = Start/stop starter Special = Special (see Remarks) WLD = 48KV Welding Socket Feeder										M1 = Single motor M2 = Double motor + 1st bus coupler M3 = Single motor + 2nd bus coupler ACDP1 = Frame 1 Auto Changer ACDP2 = Frame 2 Auto change over FDR3 = Feeder with G1 protection FDR1 = Feeder with G1 protection FDRV = Feeder to VFD CTN = 110V control transformer coil GDN = Control and Devices Cubicle										MCC TOTAL CURRENT = 1642 A			
										REV. No.		Date		Description		By:		Check:					
										B		2009/10/03		Issue for estimates		LN		DM					
										A		2009/06/01		Issue for internal approval		LN		DM					

MCC LOAD SCHEDULE										Trekkooppi Maxi													
MCC TAG NUMBER: 36-MCC-004 SERVICE: AREA F02 - HEAP LEACH PAD WASHING & FRESH WATER MCC 01 TYPE: CONTAINERISED MCC (FULLY EQUIPPED) (variable) MCC RATING: 32kV, 3 Phase, 3 Wire BUSBAR RATING: 3000A, 50kA LAYOUT DRAWING NUMBER: T.B.A										BATEMAN PROJECT NUMBER: 87348 BATEMAN DOCUMENT NUMBER: 87348-033-016 LOCATION: JUST BELOW WASH WATER POND 2/06 REMARKS: 1. STARTER PANELS IN EMERGENCY SECTION TO BE PAINTED RED 2. Operating kW Factor = 0.75; Diversity Factor = 1										REV		B	
Rev	PFD DWG No	Equipment No.	Starter Type	Equipment Description	MCC Number	Qty	Rated Output Power (kW/EMC Device)	Number of EMC devices	Total Installed Power (kW rated)	Standby (kW)	Emergency Generator Power (kVA)	Load Capacity Factor	Designed Absorbed Power (kW) (kW rated x LCF)	Power Factor at % Load per EMC Device (Alstom Catalogue)	Efficiency at % load (Alstom Catalogue)	Operational Factor (DV)	Designed Operating Load (kW)	Designed Operating Load (kVA)	Designed Operating Load (kVA)	Typical Schematic Sheet No.	Release/hold		
A		36-IR-1	IR1	INDOMER 3000A	36-MCC-004	1	3000A														H		
A		36-IR-2	ACDP1	AUTO CHANGEOVER	36-MCC-004	1	3000A														H		
A		36-PUMP-01A	FDRV	WWS PUMP	36-MCC-004	1	900.00	1	900.00		YES	0.69	480.00	0.82	0.96	0.75	603.30	505.54	422.39		H		
A		36-PUMP-01B	FDRV	WWS PUMP	36-MCC-004	1	900.00	1	900.00		YES	0.69	480.00	0.82	0.96	0.75	603.30	505.54	422.39		H		
A		36-PUMP-02C	FDRV	WWS PUMP	36-MCC-004	1	900.00	1	900.00	YES	YES	0.00	0.00	0.86	0.96	0.75	0.00	0.00	0.00		H		
A			CM	CONTROL AND DEVICES CUBICLE	36-MCC-004	1															H		
A			WLD	48KV WELDING SOCKET FEEDER	36-MCC-004	1	4.00		4.00								4.00	0.00	10.00		H		
A			CTN	1100V CONTROL TRANSFORMER WITH EP PROTECTING	36-MCC-004	1	0.50		0.50								0.50	0.00	0.50		H		
A			FDNS	LIGHTING FEEDER AND TRANSFORMER CUBICLE	36-MCC-004	1	3.00		3.00								3.00	0.00	3.00		H		
<b>TOTALS</b>										<b>9</b>		<b>1,830</b>	<b>500</b>	<b>845</b>									
DOL = Direct On Line Non Reversing Starter DOLR = Direct On Line Reversing Starter DOLM = Direct On Line Manual Non Reversing Starter DOLRM = Direct On Line Reversing Manual Starter DOLT = Direct On Line Load Shed Starter DOL2S = Direct On Line 2 speed Starter SD = Soft Starter VFD = Variable Frequency Inverter (VFD installed in the same room) SO = Start/stop starter Special = Special (see Remarks) WLD = 48KV Welding Socket Feeder										M1 = Single motor M2 = Double motor + 1st bus coupler M3 = Single motor + 2nd bus coupler ACDP1 = Frame 1 Auto Changer ACDP2 = Frame 2 Auto change over FDR3 = Feeder with G1 protection FDR1 = Feeder with G1 protection FDRV = Feeder to VFD CTN = 110V control transformer coil GDN = Control and Devices Cubicle										MCC TOTAL CURRENT = 928 A			
										REV. No.		Date		Description		By:		Check:					
										B		2009/10/03		Issue for estimates		LN		DM					
										A		2009/08/01		Issue for internal approval		LN		DM					

## **APPENDIX E: A compact laser disc (CD)**

A CD containing the following:

- E1     FLSmith pad stacking and reclaiming simulation (requires VLC media player),**
- E2     The model as a spreadsheet (excel file) with extended load list and graphs,**
- E3     The E-tap file (requires the E-tap program and licensing).**