

# **Best management practices to attain zero effluent discharge in South African industries**

**CGF Wilson**

**20222734**

Dissertation submitted in partial fulfilment of the requirements  
for the degree *Master of Engineering* at the Potchefstroom  
Campus of the North-West University

Supervisor: Prof PW Stoker  
November 2008

## ACKNOWLEDGEMENTS

I would like to thank the following people for their efforts and contributions in making this dissertation possible:

- ✚ My supervisor, Prof P Stoker, for his inspiring mentorship, guidance and willingness to assist with the study in any way possible.
- ✚ Prof H Wichers for recruiting me to the North-West University and its Masters in Engineering (Development and Management) programme, which opened many new doors for me.
- ✚ Mittal Steel for providing me with the opportunity to be project manager of the project to reach their goal of zero effluent discharge.
- ✚ Sasol for funding the final year of my studies.
- ✚ Fellow researchers and members of the industry who willingly offered their expertise and advice, particularly in terms of relevant literature.
- ✚ My friends and family for their patience and support.
- ✚ A special thought to my dad who passed away 3 months before the successful accomplishment of zero effluent discharge by Mittal Steel's Vanderbijlpark plant.
- ✚ My wife and best friend, Welma, for the sacrifices, encouragement, patience and support.

## ABSTRACT

Wastewater treatment is traditionally considered a separate part of an industrial activity, hardly connected to the production units themselves. It is nowadays essential to ensure that the quality of water is not degraded and that water that has been polluted is purified to acceptable levels, especially in a country with scarce water resources such as South Africa. Where water quality is concerned, Zero Effluent Discharge (ZED) is the ultimate goal, in order to avoid any releases of contaminants to the water environment. The push towards ZED in South Africa is also promoted further by the South African Government's plan to reduce freshwater usage and the pollution of water sources due to the water scarcity in a semi-arid South Africa. Future legislation will see a marked increase in the cost of freshwater usage and/or a possible limitation of the quantity of freshwater available. There is a need in the South African Industry for a framework of Best Management Practices (BMPs) in order to provide interested stakeholders, which include not only industry, but also academia, environmental interest groups and members of the public, with a procedure to meet the ZED statutory requirements.

This dissertation explores the regulatory requirements and current environmental management practices implemented. A framework of BMPs to successfully attain ZED status in South African industries is developed from the literature study and the researcher's own experience. The BMP framework embodies practices for one integrated strategy within three dimensions. The three dimensions of the BMP framework were selected to differentiate between BMPs for management (Governance BMPs), the project management team responsible for ZED projects (Project Management BMPs) and the implementation of preventative and operational measures to obtain and sustain ZED compliance for South African industries. The BMP framework was validated against the practices applied by Mittal Steel. The Mittal Steel plant in Vanderbijlpark implemented various projects, reduced the intake of water and eliminated the discharge of effluent and by doing this successfully realised their ZED status. The BMP framework will enable South African industries to develop their own BMPs Manual which should be specific to their operational and environmental requirements. The implementation of these BMPs should be tailored and used accordingly to demonstrate compliance to ZED requirements in South African industries.

### Keywords:

- |                            |                                |
|----------------------------|--------------------------------|
| ✚ Zero Effluent Discharge  | ✚ Effluent Separation          |
| ✚ Industrial Effluents     | ✚ Reuse of Water               |
| ✚ Water Quality Management | ✚ Water Mass Balance           |
| ✚ Water Use Efficiency     | ✚ Water Treatment Technologies |
| ✚ Water Recycling          | ✚ Best Management Practices    |

## TABLE OF CONTENTS

ACKNOWLEDGEMENTS _____	I
ABSTRACT _____	II
TABLE OF CONTENTS _____	III
LIST OF TABLES _____	VII
LIST OF FIGURES _____	VIII
LIST OF FIGURES _____	VIII
LIST OF ACRONYMS _____	IX
<b>CHAPTER 1 INTRODUCTION _____</b>	<b>1</b>
1.1 Introduction _____	1
1.2 Problem Statement _____	2
1.3 Hypothesis and Objective - Best Management Practices to attain Zero Effluent Discharge in the South African Industry _____	2
1.4 Overview of Dissertation _____	3
1.5 Limitations and Key Assumptions _____	4
<b>CHAPTER 2 LITERATURE STUDY: ENVIRONMENTAL LEGISLATION AND WATER GOVERNANCE _____</b>	<b>5</b>
2.1 Introduction _____	5
2.2 The Environment, Legislation and the Industry _____	5
2.2.1 Introduction _____	5
2.2.2 The African and South African Perspective _____	7
2.2.3 Legislation - Managing the Environment _____	8
2.2.4 Conclusion _____	21
2.3 Principles of Water Use Efficiency _____	21
2.3.1 Introduction _____	21
2.3.2 Water Use Efficiency in Industry _____	23
2.3.3 Physical Dimension of Water Use Efficiency _____	25
2.3.4 Technological Dimension _____	29
2.3.5 Social Dimension _____	31
2.3.6 Economic Dimension _____	34

2.3.7	Environmental Dimension	38
2.3.8	Conclusion	38
2.4	Conclusion	39
<b>CHAPTER 3 LITERATURE STUDY: CASE STUDIES</b>		<b>40</b>
3.1	Introduction	40
3.2	<b>Case Study - Effluent Management for a Metal Finishing Industry aiming at Zero Discharge Conditions</b>	<b>40</b>
3.2.1	Introduction	40
3.2.2	Description of the Industry and Production Processes	40
3.2.3	Water Consumption and Quality Requirements for Various Water Uses	41
3.2.4	Wastewater Generation and Different Types of Process Wastewaters	42
3.2.5	Treatment Requirements	42
3.2.6	Water Balance	45
3.2.7	Conclusion	47
3.3	<b>Case Study - Best Management Practices: Marine Products Processing</b>	<b>47</b>
3.3.1	Introduction	47
3.3.2	Description of the Industry, Production Processes and Organic Pollution	48
3.3.3	Environmental Regulations	48
3.3.4	How to Measure Organic Pollution	49
3.3.5	Best Management Practices	51
3.3.6	Conclusion	60
3.4	Conclusion	61
<b>CHAPTER 4 BMP FRAMEWORK TO ATTAIN ZED IN SOUTH AFRICAN INDUSTRIES</b>		<b>62</b>
4.1	Introduction	62
4.2	<b>Governance BMPs</b>	<b>64</b>
4.2.1	Corporate Policies	64
4.2.2	Sustainability	64
4.2.3	Legal Responsibility	65
4.2.4	Social Responsibility	67
4.2.5	Health and Safety Responsibility	68
4.2.6	Environmental Responsibility	69
4.2.7	Environmental Impact Assessment	70
4.2.8	Economic Responsibility	73
4.3	<b>Project Management BMPs</b>	<b>74</b>
4.3.1	Establish a Team	74
4.3.2	Draw up a Communication Protocol	75

4.3.3	Project Scope and Integration Practices _____	76
4.3.4	Cost Management Practices _____	78
4.3.5	Time Management Practices _____	79
4.3.6	Quality Management Practices _____	79
4.3.7	Project Risk Management Practices _____	80
4.3.8	Procurement Practices _____	81
4.3.9	Contractor Management _____	82
<b>4.4</b>	<b>Water Use Efficiency, Preventative and Operational BMPs _____</b>	<b>83</b>
4.4.1	Create Environmental Awareness through Educational Programmes _____	83
4.4.2	Develop Production Process Flow Sheets and Measure Sources of Pollution _	84
4.4.3	Water Quality Requirements and Water Mass Balance _____	85
4.4.4	Reduce Water Consumption _____	87
4.4.5	Pollution Prevention at Source _____	88
4.4.6	Effluent Separation, Recycling and Reuse of Water _____	90
4.4.7	Use of Chemical and Hazardous Products _____	90
4.4.8	Residues Management _____	91
4.4.9	Treatment Technologies _____	91
4.4.10	Emergency Plans for Unplanned Releases _____	92
4.4.11	Establish Verification Measures _____	93
<b>4.5</b>	<b>Conclusion _____</b>	<b>94</b>
<b>CHAPTER 5</b>	<b>ZED CASE STUDY: MITTAL STEEL, VANDERBIJLPARK _____</b>	<b>95</b>
5.1	Introduction to Case Study Approach _____	95
5.2	Reasons for Choosing Mittal Steel Vanderbijlpark as Case Study _____	95
5.3	Mittal Steel at a Glance _____	97
5.4	Mittal Steel and Corporate Governance _____	100
5.5	Mittal Steel's Commitment to a Cleaner Environment _____	102
5.5.1	Mittal Steel's progress towards ZED _____	102
5.6	Mittal Steel Environmental Master Plan _____	105
5.7	The Evolution of the Process Waters Master Plan Concepts _____	107
5.7.1	Introduction _____	107
5.7.2	Process Water Master Plan Methodology and Approach _____	109
5.7.3	Process Water Master Plan Baseline Studies _____	110
5.7.4	Process Water Master Plan Strategy _____	114
5.7.5	Initial Qualitative Findings and Short-term Measures _____	114
5.7.6	Summary of Mittal Steel Vanderbijlpark ZED Concept _____	115
5.8	The Mittal Steel MTP Project _____	115

5.8.1	Introduction_____	115
5.8.2	Governance and Management of the MTP Project_____	116
5.8.3	High Level Description of the Scope of the MTP Project _____	116
5.9	Conclusion _____	126
<b>CHAPTER 6</b>	<b>VALIDATION _____</b>	<b>127</b>
6.1	Introduction _____	127
6.2	Validation of Governance BMPs _____	127
6.3	Validation of Project Management BMPs _____	129
6.4	Validation of Water Use Efficiency, Preventative and Operational BMPs_____	130
6.5	Conclusion _____	131
<b>CHAPTER 7</b>	<b>CONCLUSION AND RECOMMENDATIONS_____</b>	<b>132</b>
7.1	Conclusion _____	132
7.2	Recommendations _____	133
7.3	Recommendations for further Research_____	133
<b>BIBLIOGRAPHY</b>	<b>_____</b>	<b>134</b>
<b>APPENDICES</b>	<b>_____</b>	<b>138</b>
	<b>Appendix A: Table of Contents of an Example for the Evaluation and Selection of Available Processes for a ZED System _____</b>	<b>138</b>
	<b>Appendix B: Water and the Millennium Development Goals_____</b>	<b>146</b>

## LIST OF TABLES

Table 2.1: Characteristics of Environmental Impacts _____	19
Table 2.2: Innovative Reclaimed Water Partnership in the Durban Area_____	28
Table 2.3: Some Capacity Assessment Tools_____	33
Table 2.4: The high Cost of Coping with Source Water Pollution in selected Communities in the US_____	37
Table 3.1: Quality Requirements for Different Water Uses in the Plant _____	41
Table 3.2: Characterisation of Segregated Streams_____	43
Table 3.3: Inventory of Products Used During One Hour by the Production Process. _____	53
Table 3.4: Inventory of the Products Generated During One Hour by the Production Process. _____	54
Table 3.5: Initial Compilation of the Physicochemical Characteristics of Various Effluents	55
Table 3.6: Organic Pollution Critical Points Compilation and Analysis_____	56
Table 3.7: Compilation of Continuous Measures of Verification of the Performance of the BMP _____	59
Table 5.1: Pollutants during Steel Making Process_____	98
Table 5.2: Mittal Steel Corporate Social Strategy _____	101

## LIST OF FIGURES

Figure 2.1:	The Reiterative Policy Making Process _____	6
Figure 2.2:	Hierarchy of Legislation _____	10
Figure 2.3:	The Linear and Non-Linear Policy Models _____	13
Figure 2.4:	Integrated Planning Approach at Various Levels of Government in South Africa _____	15
Figure 2.5:	Environmental Impact Assessment Process _____	18
Figure 2.6:	Dimensions of Water Governance _____	23
Figure 2.7:	Trends in Industrial Water Use by Region, 1950-2000 _____	24
Figure 2.8:	Total World Industrial Water Use, 1950-2000 _____	24
Figure 3.1:	Schematic Process Diagram for Process Wastewater Streams _____	44
Figure 3.2:	Water Balance for Summer and Favourable Weather Conditions _____	46
Figure 4.1:	Structure of BMPs Framework _____	63
Figure 5.1:	Process Flow at Vanderbijlpark Steel _____	99
Figure 5.2:	Mittal Steel Environmental Reporting Hotline _____	104
Figure 5.3:	Mittal Steel Process Water and Dry Weather Water Balance _____	113
Figure 5.4:	CETP Process Flow _____	118
Figure 5.5:	Previous Effluent Treatment System _____	119
Figure 5.6:	MTP Concept _____	122
Figure 5.7 :	MTP Process flow _____	124

## LIST OF ACRONYMS

ASGISA	Accelerated and Shared Growth Initiatives of South Africa
BCs	Brine Concentrators
BCR	Benefit Cost Ratio
BMPs	Best Management Practices
BODS <sub>SOLUBLE</sub>	Soluble Biochemical Oxygen Demand
BODS <sub>TOTAL</sub>	Total Biochemical Oxygen Demand
CETP	Central Effluent Treatment Plant
CIDA	Canadian International Development Agency
Cl	Chloride
CMAs	Catchment Management Agencies
CMP	Critical Management Point
CMSs	Catchment Management Strategies
CN	Cyanide
COD <sub>SOLUBLE</sub>	Soluble Chemical Oxygen Demand
COD <sub>TOTAL</sub>	Total Chemical Oxygen Demand
CPA	Cleaner Production Assessment
Cr (total)	Total Chromium
Cr <sup>6+</sup>	Hexavalent Chromium
DWAF	South African Department of Water Affairs and Forestry
EAP	Environmental Assessment Practitioner
ECA	Environmental Conservation Act 73 of 1989
EDR	Electrodialysis Reversal
EIA	Environmental Impact Assessment
EIRs	Environmental Impact Reports
EISs	Environmental Impact Statements
EU	European Union
F	Fluor
Fe	Iron
FO	Forward Osmosis
FOG	Fats, Oils and Grease
GAC	Granulated Activated Carbon
GDACE	Gauteng Department of Agriculture, Conservation and Environmental Affairs
GNR	Government Notice
GRI	Global Reporting Initiative
GTZ	German Technical Cooperation
GWP	Global Water Partnership
I&AP	Interested and Affected Parties
IDRC	International Development Research Centre
IEM	Integrated Environmental Management
IIRR	International Institute of Rural Reconstruction
IISI	International Iron and Steel Institute
IRR	Internal Rate of Return
ISNAR	International Service for National Agricultural Research
ISO	International Standards Organisation

IWRM	Integrated Water Resource Management
K	Potassium
kg/h	Kilogram per Hour
KM <sub>n</sub> O <sub>4</sub>	Potassium Permanganate
m <sup>3</sup>	Cubic Meter
m <sup>3</sup> d-1	Cubic Meter per Day
m <sup>3</sup> /h	Cubic Meter per Hour
MCCs	Motor Control Centres
MD	Membrane Distillation
MDGs	Millennium Development Goals
MEAs	Multilateral Environmental Agreements
mg/L	Milligram per Litre
Mn	Manganese
MTP	Main Treatment Plant
N	Nitrogen
Na	Sodium
NEMA	National Environmental Management Act 108 of 1998
NGO	National Government Organisation
NH <sub>3</sub>	Ammonia
NH <sub>3</sub> -N	Ammonia expressed as Nitrogen
NO <sub>2</sub>	Nitrite
NO <sub>2</sub> -N	Nitrite expressed as Nitrogen
NO <sub>3</sub>	Nitrate
NO <sub>3</sub> -N	Nitrate expressed as Nitrogen
NPV	Net Present Value
NWA	National Water Act 36 of 1998
NWRS	National Water Resource Strategy
OFT	Ockie Fourie Toxicologists United States Department of Labour's Occupational Safety and Health Administration
OSHA	
P	Phosphor
P <sub>SOLUBLE</sub>	Soluble Phosphorus
P <sub>TOTAL</sub>	Total Phosphorus
PCDD/F	Polychlorinated dibenzofuran
pH	Measure of alkalinity and acidity
RO	Reverse Osmosis
RoD	Record of Decision
RPA	Richard Paxton and Associates
S	Sulphur
SACI	South African Capacity Initiative
SEAs	Strategic Environmental Assessments
SH&E	Safety, Health and Environmental
SiO <sub>2</sub>	Silica
Sn	Tin
SO <sub>4</sub>	Sulphate

SO <sub>4</sub> -S	Sulphate expressed as Sulphur
SPARRO	Slurry Precipitation And Recycle Reverse Osmosis
TDS	Total Dissolved Solids
TETP	Terminal Effluent Treatment Plant
TKN	Total Kjeldahl Nitrogen
TKN <sub>SOLUBLE</sub>	Soluble Kjeldahl Nitrogen
TS	Total Solids
TSS	Total Suspended Solids
TVEf	Total Volume of Effluents
TVPW	Total Volume of Potable Water
UNDP	United Nations Development Programme
VEf	Volume of Effluents
VPW	Volume of Potable Water
WMA	Water Management Areas
WQG	South African Water Quality Guidelines
WSSD	World Summit on Sustainable Development
WWDR 2	United Nations World Water Development Report 2
XLZR	Crystallisers
ZED	Zero Effluent Discharge
Zn	Zinc

## CHAPTER 1 INTRODUCTION

### 1.1 Introduction

Worldwide a wealthy economy and improvement in the quality of life are directly linked to better access to consumer goods. Growing local industries create much needed jobs, therefore people have more disposable income to spend on manufactured products. Unfortunately this often comes at the cost of increasing pollution in the form of dumped solid waste, deteriorating water quality and increased air pollution when industry discharges untreated wastes onto land and into the air and water. However, the linkage between industry and pollution is avoidable. The United Nations World Water Development Report 2 (WWDR 2) indicates that manufacturing activities can both be clean and profitable (UNESCO, 2006:276-302). Governance and applying appropriate legislation has an important role to play in creating the environment that promotes healthy and sustainable industrial growth.

The South African Department of Water Affairs and Forestry (DWAF) acknowledged the fact that water is one of the most fundamental and indispensable of all natural resources. “It is fundamental to life and the quality of life, to the environment, food production, hygiene, industry, and power generation. The availability of affordable water can be a limiting factor for economic growth and social development, especially in South Africa where water is a relatively scarce resource that is distributed unevenly, both geographically and through time, as well as socio-politically.” (DWAF, 2004:1.) Planning for the water needs of the country in the future is a complex task, and non-conventional areas must now be addressed to supplement the two major areas of water resource management and water demand management. Internationally, especially in countries which have water shortages similar to that in South Africa, water reclamation is becoming increasingly common.

Both water quantity and quality need to be considered in the challenge of improving industrial water use. It is essential to ensure that the quality of water should not be degraded and that water that has been polluted should be purified to acceptable levels, especially in a country with scarce water resources such as South Africa.

Where water quality is concerned, Zero Effluent Discharge (ZED) is the ultimate goal, in order to avoid any release of contaminants into the water environment. The push towards ZED in South Africa is also promoted further by the South African Government’s plan to reduce freshwater usage and the pollution of water sources due to the water scarcity in a semi-arid South Africa. Future legislation will see a marked increase in the cost of freshwater usage and/or a possible limitation of the quantity of freshwater available (DWAF, 2004:2).

## **1.2 Problem Statement**

Considering the legislation regarding the environment today and more strict laws on the horizon, companies are forced to focus on the environmental impacts that result from their businesses. One of these impacts involves the requirements for the discharge of effluents and the ultimate goal of becoming ZED compliant. The ZED concept is still in its infancy, but the need to comply with ever increasing environmental challenges is forcing industries to plan for the implementation of ZED practices to support their own sustainability.

The industrial sector is a major contributor to the economic wealth of South Africa. Although South Africa at large is responding to the global requirements to protect the environment and ensure a better quality of life through improved environmental responsibility, the negative impact of the industrial sector is still a concern. There is a need to increase the South African industrial sector's knowledge base on water governance in order to adopt a pro-active planning and management approach.

There is a need in the South African industry for a framework of Best Management Practices (BMPs) in order to provide interested stakeholders, which include not only industry, but also academia, environmental interest groups and members of the public, with a procedure to meet the ZED statutory requirements.

## **1.3 Hypothesis and Objective - Best Management Practices to attain Zero Effluent Discharge in the South African Industry**

The objective of this research is to identify current environmental management practices and to develop a framework of practices to successfully attain ZED status in the South African industry. This dissertation is intended to provide South African industry with a framework of BMPs to attain a ZED status, thereby enabling it to comply with environmental regulations to reduce and prevent contamination of the aquatic environment. These practices represent a set of successful approaches, procedures and guidelines. If the framework is implemented, it should result in responsible, sustainable and legally compliant effluent management. These BMPs have been tested against the already implemented solution to meet the legal requirements of ZED for the Mittal Steel plant in Vanderbijlpark.

The intent is not to formulate a regulatory document, but to provide organisations in industry experiencing similar ZED challenges with a procedure whereby they can identify and implement effective and economical measures for treating their effluent. Industry should use the BMP framework and determine which of these practices are pertinent to their unique facility, and implement the BMPs to ensure they remain sustainable and legally compliant at all times.

## 1.4 Overview of Dissertation

The following protocol is used in this case study research:

Chapter Two presents a literature survey which focuses on the need for management principles towards achieving ZED as a result of the ever increasing environmental requirements. The chapter presents an overview of the environmental legislative requirements and the principles of water use efficiency for industries. Water use efficiency includes any measure that reduces the quantity of water used per any given unit of activity, consistent with the maintenance or enhancement of water quality.

Chapter Three consists of two case studies describing effluent management and BMPs in two industries. The case studies described in this chapter were selected because they represent circumstances in which many BMPs have been implemented with considerable success. From the literature survey and these case studies a framework has been established to attain ZED in the South African industry.

- ✚ The first case study focuses on effluent management for a metal finishing industry aiming at zero discharge conditions. The study evaluates technical implications of zero discharge condition for a large metal finishing plant as a representative case study.
- ✚ The second case study focuses on the best management practices of marine products processing. This study is included because processing of marine products requires large volumes of water which have a direct consequence of large volumes of effluent.

Chapter Four contains the BMPs to attain ZED in the South African industry. The BMPs were derived from:

- ✚ Interpretation of the intent of existing regulatory requirements described in Chapter Two as it applies to a variety of contaminants and waste streams and the principles of effective water governance.
- ✚ Review of practices from the case studies described in Chapter Three.
- ✚ The researcher's own experience.

Chapter Five summarises the state of affairs at the Mittal Steel plant in Vanderbijlpark and illustrates the process the Mittal Steel plant followed to reduce the intake of water and eliminate the discharge of effluent from its boundaries. The case study addresses the BMPs applied by Mittal Steel in compiling their environmental master plan and the execution of the project to bring about Mittal Steel's ZED compliance.

Chapter Six contains the validation of the application of the BMPs used by Mittal Steel as summarised in Chapter Five.

Chapter Seven consist of a summary, conclusions and recommendations and the document is concluded with a list of the sources referred to in this research.

### **1.5 Limitations and Key Assumptions**

This document does not intend to be a model in the design or maintenance of a water plant, because the application is normally site specific. BMPs to attain ZED are formulated from the literature survey, case studies and the researcher's own experience and then validated against the Mittal Steel application. Additional BMP frameworks may also need to be implemented by other South African industries, based on the facilities' specific effluent requirements and site specific conditions.

## CHAPTER 2 LITERATURE STUDY: ENVIRONMENTAL LEGISLATION AND WATER GOVERNANCE

### 2.1 Introduction

The intention of the BMPs is to provide industry with guidelines to keep pollutants from the effluent entering the neighbouring aquatic environment and to remain compliant with regulatory requirements. Environmental governance is crucial in the management of growing industries to ensure an acceptable level of pollution control and environmental management. Various international conventions and Multilateral Environmental Agreements (MEAs) exist in order to regulate industry. The need for management principles in order to be a ZED facility is a result of the ever increasing environmental requirements.

High on the list of environmental management is the need for an integrated and holistic approach to water resource management. In the WWDR 2 it is concluded that water managers around the world agree that the only way forward is through an inclusive and integrated approach to water resource management. “Integrated Water Resources Management (IWRM) promotes not only cross-sectorial cooperation, but the coordinated management and development of land, water (both surface water and groundwater) and other related resources, so as to maximize the resulting social and economic benefits in an equitable manner, without compromising ecosystem sustainability.” (UNESCO, 2006:13.)

This chapter focuses on the need for management principles in order to be a ZED facility. The first section is a literature study of the ever increasing environmental requirements and presents an overview of the environmental legislative situation and requirements for industries. The second section illustrates the importance of water use efficiency in determining a framework for ZED. This reference provides good guidelines for ZED BMPs, however, it does not address in any detail specific treatment technologies and operational procedures. The two case studies included in Chapter Three will, however, address practices in this regard.

### 2.2 The Environment, Legislation and the Industry

#### 2.2.1 Introduction

“We did not inherit the earth from our  
ancestors - we borrow it from our children”

*Navajo Proverb*

Over many centuries environmental protection or management was not regarded an issue as

such by Western civilisation. Few people saw the way in which the earth was exploited as a risk to the future quality of life. A possible explanation for this was that a balance was maintained between the impact of the exploitation of the environment and the environment's carrying capacity, or the ability of the natural resources to absorb the impacts on the environment. Now, however, the increasing population and the effect of growing industrialisation combined put enormous pressure on natural resources world-wide.

Nowadays structured thinking about environmental issues is part and parcel of the approach of governments, industry, NGOs, businesses and the average person. These environmental pressures have forced extensive changes in global legislation, South Africa included, despite its years of political isolation. Legislative changes favour better environmental management and a more advanced level of environmental protection.

Integrated Environmental Management must consider the impact on *inter alia*, the environment, socio-economic conditions and our cultural heritage. Anybody following the news today will be familiar with environmental issues such as *Global warming, Ozone layer depletion, Acid rain, Biodiversity, Deforestation*, and many others. Figure 2.1 was included in the WWDR 2 and illustrates different steps in a holistic policy making process (Gutrich *et al.*, 2005).

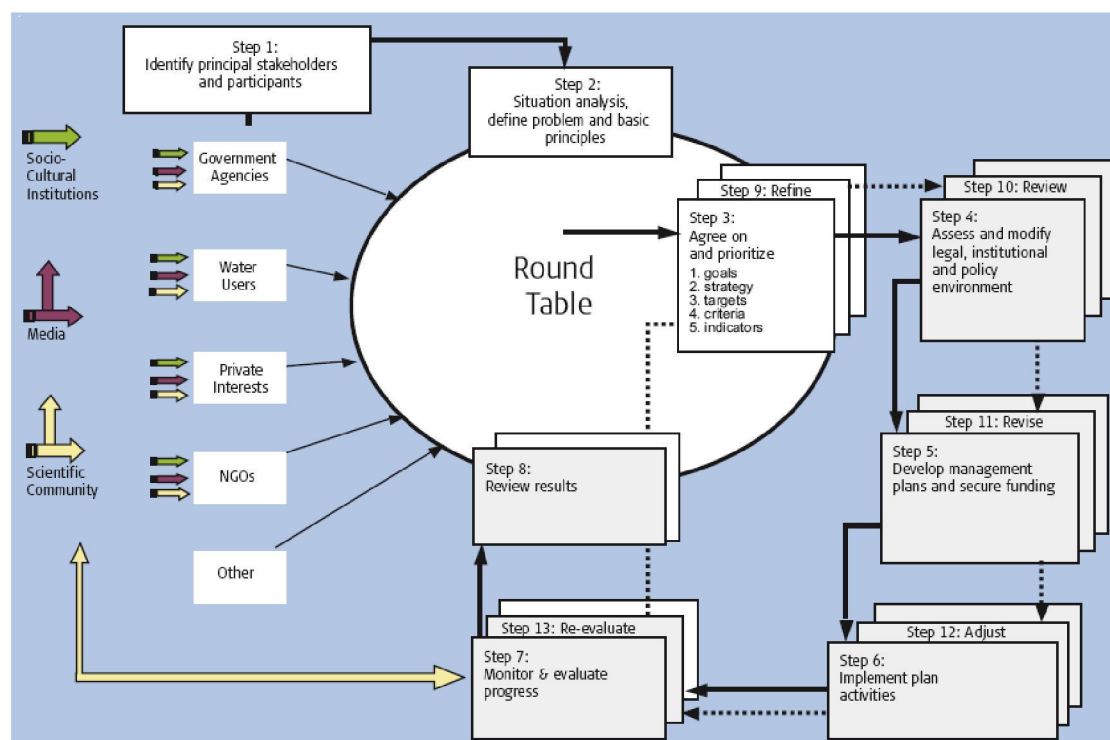

**Figure 2.1: The Reiterative Policy Making Process**

(Gutrich *et al.*, 2005: 197-209)

In an Environmental Impact Assessment presentation to Mittal Steel, the environmental

management consultant, Dr Pieter Aucamp, classified the different types of business environmentalism as one of the following:

- ✚ head in sand;
- ✚ knee jerk (people who only reacts when something happens);
- ✚ green gloss (only surface polishing of environmental issues);
- ✚ heads down (minimum compliance);
- ✚ pro-active (internally driven); and
- ✚ those with a proper understanding of sustainability concepts. (Aucamp, 2006:10).

The environmental debate has become progressively more vigorous. Contributing to the debate are environmental philosophers, the media, environmental activists, international organisations, agreements, treaties and conferences, and incidents with major environmental impacts which have made headline news. The purpose of Section 2.2 of this document is merely to draw attention to, and not to further the debate on the impact the legislative process has had so far on industries and the environment, which necessitated the development of BMPs by Industry.

### **2.2.2 The African and South African Perspective**

Environmentally speaking, Africa places extreme demands on its people. The environmental realities of Africa leave little leeway for mistakes. There are numerous sources of literature with statistics indicating that Africa is characterised by irregular rains and a shortage of water, a variety of pests and diseases, extremes in temperature, an upsetting variation in the availability of resources and numerous other environmentally demanding factors.

The challenges facing Africans might not be more severe than the challenges facing communities in other parts of the world. They are, however, unique to Africa. Barnard explains that over the ages the people of Africa have learnt to develop environmental management systems to ensure their survival. “A failure to plan and live according to the vicissitudes of Africa meant death. Africans practised sustainable development because they had no choice. They knew the yield capability of the land on which they lived and planned their activities around this fact.” (Barnard, 1999:31.)

“The position changed when colonial powers, having secured land after the ‘Scramble for Africa’, introduced new management systems. The existing systems were regarded as inferior. The imperialist masters favoured systems that in their opinion could improve land use in Africa. This short sighted approach led to the destruction of reliable systems that had been built over the ages.” (Barnard, 1999:31.)

Africa now faces many problems. It must cope with major sins of the past and must deal with the protection of its environment. It is not the duty of only the environmental planners and decision makers to re-establish the sustainable environmental management practices that were lost, but also of each and everyone in society.

The development of environmental legislation in South Africa reflects a growing environmental awareness. On evaluating all the different debates, one might conclude that all contributors shared the realisation that this involvement was essential for the future of the country and the environmental awareness has actually grown substantially since 1990. The South African Government has accepted that it is the duty of both the state and its subjects to comply with appropriate international legislation.

This is being acknowledged by the United Nations in their WWDR 2: “At the other end of the world, driven by South Africa’s reforming government, significant changes are occurring in the Southern African region in both attitudes and techniques of water management. The biggest changes are in South Africa itself, but their ideas are spreading to adjacent countries. There are some limited parallels with the European Union (EU) in that change is being driven by a wealthier core nation with strong institutions and clearly articulated equitable values, and is rippling out from there. In both the EU and Southern Africa, the process of change is underpinned by institutional values that emphasize inclusiveness of both the whole population and the needs of the natural environment. The water laws and regulations of both of these regions, especially at the core of them, are characterized by commitment to equality of access to water for all and to environmental protection of a more sophisticated nature (relatively speaking in each case) than almost anywhere else on the planet.” (UNESCO, 2006:13).

The BMP framework developed in Chapter Four will be of the utmost importance for industries to support this environmental commitment made by implementing these water laws and regulations.

### **2.2.3 Legislation - Managing the Environment**

#### **2.2.3.1 Environmental Law**

“Law is not just an abstract set of rules imposed on society but is an integral part of that society deeply rooted in the social and economic order in which it functions and embodying traditional value systems which confer meaning and purpose upon the given society.” (Dennis, 1964:252)

Over the centuries a considerable body of law has been created that affects man's relationship with his environment. The law of nuisance dates back thousands of years. The *Conservation of Agricultural Resources Act* dates back to 1983. Both are important components of contemporary environmental law. (Barnard, 1999:14). Previously there was no reason to bring together all environmental law rules in one convenient branch. The management of the environment was neither regarded important nor was it dealt with in an integrated and comprehensive manner. It was only recently that environmental management was accepted as an important discipline. It is now generally accepted that environmental law has become a fully-fledged branch of legislation. The main thrust of environmental law is to manage the relationship between humankind and the earth.

The fact that environmental law has emerged as a branch of legislation does not mean that it should be considered in isolation from other legislative embranchments. In fact, many principles forming part of neighbour law, administrative law, criminal law, the law of delict, constitutional law and other legislative branches also form part of environmental law. For effective environmental management it is necessary to bear in mind that no other branch of law interacts quite as extensively and regularly with other legal and non-legal disciplines. (Barnard, 1999:15).

Thus the environmental protection of a property from water pollution by applying the *National Water Act* involves legislation from several other branches. Barnard explains cleverly how pollution deals with land and, as land is property, the law of things applies. In order to apply the *National Water Act* the rules of administrative law must be applied. As the pollution of water is an offence, the criminal law must be applied. In proving the case against the polluter, the law of criminal procedure, which is part of formal law, must be applied. Constitutional law is also involved as the complainant who laid the charge relies, amongst others, on the right to an environment that is not harmful to his health and well-being as protected in the *Bill of Rights*. (Barnard, 1999).

In his presentation Dr Pieter Aucamp explained the complexity of the legislative process regarding the environment and pointed out that there are nearly 100 environmental acts. The illustration in Figure 2.2 of the Hierarchy of Legislation for the Environment (Aucamp, 2006: 28) is equally intertwined as the previously indicated reiterative holistic policy making process in the WWDR 2.

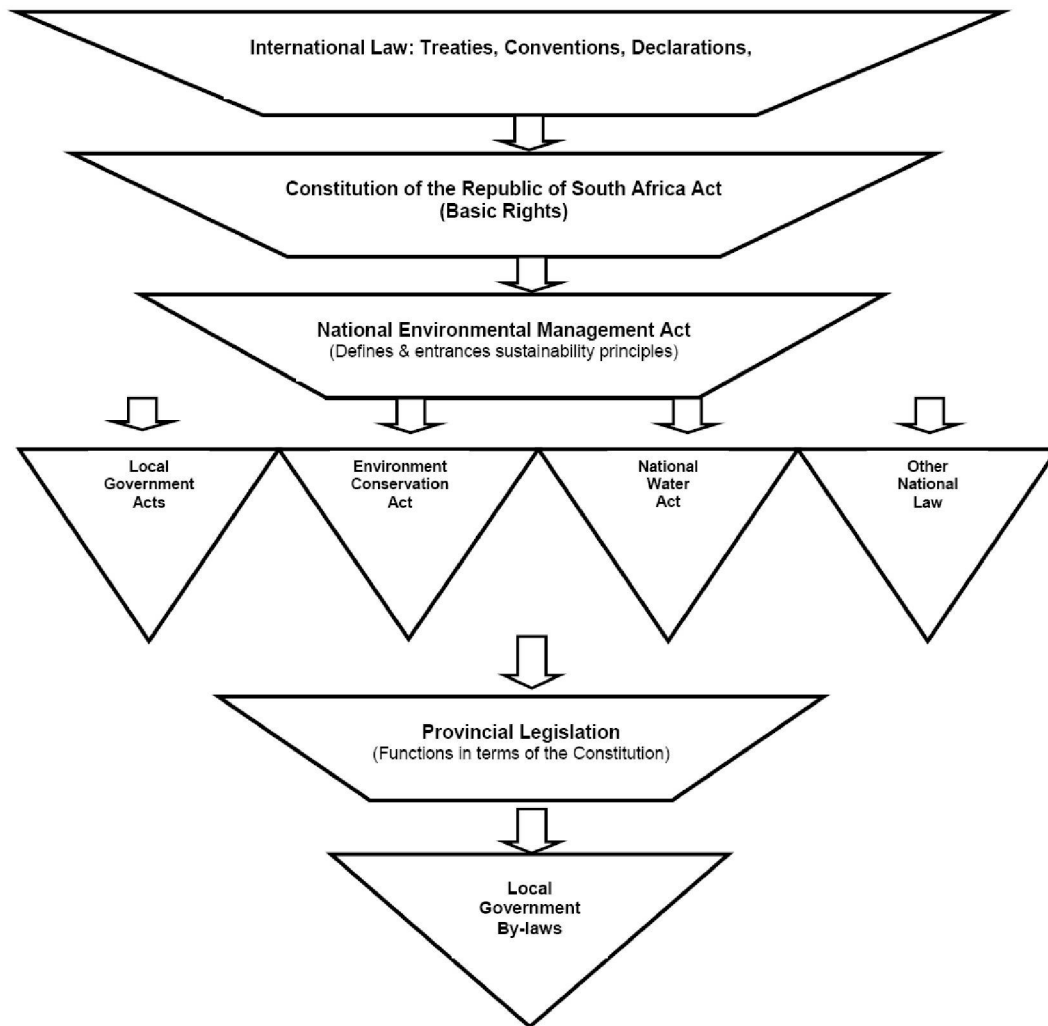

**Figure 2.2: Hierarchy of Legislation**

(Aucamp, 2006:28)

Environmental law has moved from relative obscurity to prominence in a short time. The importance of contemporary international law and especially international environmental law is marked by the extent to which it increasingly influences business, cultural, recreational and other activities of the members of the international community in their capacity as the subjects of states.

Political isolation over several decades resulted in South Africa being left out in the cold while the international community developed a wide range of legal guidelines, in particular regarding environmental law. Since South Africa has now been re-admitted into the international community, it has accepted the international principles. Environmental legislation is undergoing significant reform in South Africa and the force behind this is the support of the overall national objective of sustainable development. (Agenda 1997, 21:2).

The *Bill of Rights* is contained in Chapter 2 of the *Constitution of the Republic of South Africa Act 108 of 1996* (1996a). The comprehensive protection of environmental rights is contained in section 24 under the heading “Environment”.

- ✚ Section 24(a) states: “Everyone has the right - (a) to an environment that is not harmful to their health or well-being; ...”.(1996b). Although the “health” or “well-being” of people cover a wide field, this enactment fits well into the spectrum of internationally accepted principles protecting the quality of life of people.
- ✚ Section 24(b) states: “Everyone has the right... (b) to have the environment protected, for the benefit of present and future generations, through reasonable legislative and other measures that - (i) prevent pollution and ecological degradation; (ii) promote conservation; and (iii) secure ecologically sustainable development and use of natural resources while promoting justifiable economic and social development”. (1996b).

The enforcement of the environmental rights in section 24 in the *Bill of Rights* is facilitated by several subsidiary measures, policies and numerous Acts.

#### **2.2.3.2 Quantifying Environmental Impacts**

One of the major components of environmental management is the identification of the different courses of conduct that can be followed and the choice of the most acceptable alternative. This will have an influence on the validity in selecting a specific BMP. It is only possible to make a valid and reliable choice if the alternative courses of conduct can be compared effectively. It is essential to make an effort to quantify environmental goods or impacts. The ability to quantify environmental goods and impacts financially is also essential for other reasons. The business community must make decisions concerning the environment that could have major financial and legal implications for their organisations. They need to be able to justify their decisions, which they cannot do on vague and valueless bases of comparison.

Reliable quantification has furthermore become particularly important as legislation explicitly and by implication requires it. It is specifically required in section 2(4)(i) of the *National Environmental Management Act 107 of 1998* (NEMA) where it is stated that “the social, economic and environmental impacts of activities, including disadvantages and benefits, must be considered, assessed, and evaluated, and decisions must be appropriate in the light of such consideration and assessment.” (1998a). This section can be complied with only if the impacts are quantified to financial figures.

Section 2(4)(p) of the NEMA states that “the costs of remedying pollution, environmental degradation and consequent adverse health effects and of preventing, controlling or minimising further pollution, environmental damage or adverse health effects must be paid for by those responsible for harming the environment”. (1998a). Again compliance with this section can only be effected if the impacts are quantified to financial figures. Development must meet with the requirements of sustainability. In essence these sections require that all present or planned developments should be analysed to determine whether they cause or might cause external costs. “Externalities, also called external costs, spillovers or social costs, are costs generated by the producer but carried or paid by someone else.” (Barnard, 1999:101) Barnard explains the considerations involved in shifting the cost burden back to the producer of the cost. The process is called *internalisation of externalities*.

“It is generally accepted that the judicious use of a pricing mechanism can facilitate effective environmental management. This aspect of environmental management in general was investigated in a project launched in 1991 and undertaken for the Department of Environment Affairs by Economic Project Evaluation (Pty) Ltd, under the auspices of the Departmental Steering Committee for Environmental Resource Economics. Water management in particular was researched and the findings were published as *The application of economics to water management in South Africa*. The White Paper *A National Water Policy for South Africa*, issued by the Department of Water Affairs and Forestry in April 1997 accepts the principle of using a water-pricing policy in paragraph 6.5.3.” (Mirrilees, *et al.*, 1994). The *National Water Act 36 of 1998* (NWA) also introduces this policy in sections 56 to 62 (1998b). The pricing strategy can be applied to achieve social equity, to fund costs of water resource management, development and use, and to achieve an equitable and efficient allocation of water. Water quality management can be supported by applying the ‘polluter pays’ principle. In this regard a typical application of these principles is contained in section 56(6) that states “(i)n setting a pricing strategy for water use charges, the Minister ... (b) may consider incentives and disincentives - (i) to promote the efficient use and beneficial use of water; (ii) to reduce detrimental impacts on water resources; and (iii) to prevent the waste of water.” (1998b).

Although it is inevitable that the quantification will not be exact, an honest attempt must be made to assign realistic values to the environmental considerations using available technology.

### **2.2.3.3 Water Management in South Africa**

The WWDR 2 included two models by Gooch and Huitema (2004) illustrating the multitude of role players, decisions and processes in the making of water policies. One model indicates the linear policy model, which is the ideal and theoretical model with typical

stages of policy making. The second model indicates a more realistic version of the factors shaping policy formulation and implementation. “Policy-making is not a straightforward linear process, but rather a ‘messy’ business, in which various actors with different interests, stakes and powers are trying to influence the policy outcome while different policy stages are interlinked and sometimes done in a simultaneous fashion. What the policy process looks like, what actors are involved and other concerns differ among various development contexts and depend on what water challenges the policy is intended to address.” (UNESCO, 2006:58). South Africa is the leader on the African continent with implementation of processes resulting in new policies, strategies and laws for managing their water resources.

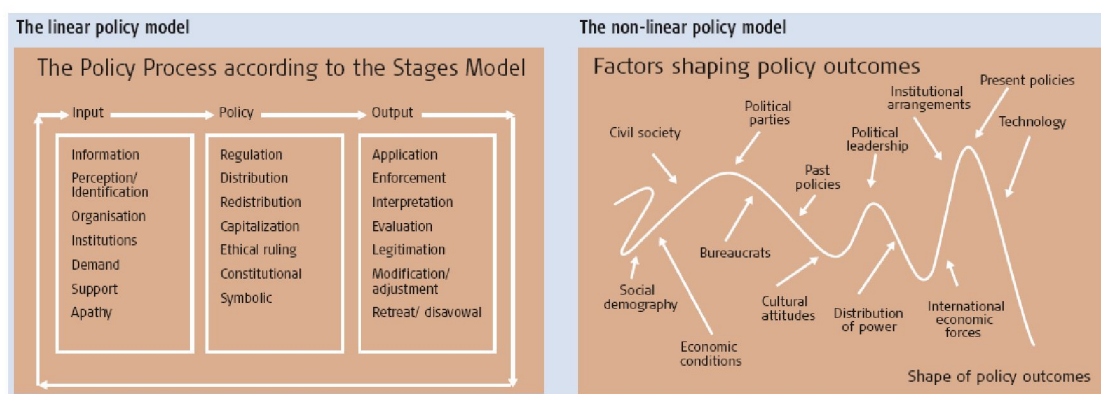

**Figure 2.3: The Linear and Non-Linear Policy Models**

(Gooch and Huitema, 2004)

“Water is one of the most fundamental and indispensable of all natural resources. It is fundamental to life and the quality of life, to the environment, food production, hygiene, industry, and power generation. The availability of affordable water can be a limiting factor for economic growth and social development, especially in South Africa where water is a relatively scarce resource that is distributed unevenly, both geographically and through time, as well as socio-politically. Prosperity for South Africa depends upon sound management and utilisation of our many natural and other resources, with water playing a pivotal role. South Africa needs to manage its water resources optimally in order to further the aims and aspirations of its people.” (DWA, 2004:1.) Conley confirmed that the greater part of South Africa is semi-arid and subject to variable rainfall, droughts, floods, and high evaporation. Furthermore, underground water reserves are limited and freshwater lakes are a rarity in South Africa. (Conley, 1992). Water management requires that the available water is managed properly and equitably and that the quality of available water is protected.

“A process of intensive public participation resulted in the promulgation of the *National Water Act 36 of 1998 (NWA)*. The Act drastically changed the basis of water management.

Before analysing the water management regime introduced by the *National Water Act*, the background both to the management of water quantity and of water quality management is considered.” (Barnard, 1999:261) The NWA is structured around the following priorities: “that water is scarce, that it is unevenly distributed, that it belongs to all people; that all aspects of water resources must be managed in an integrated manner, and that water management must achieve sustainable use and must protect its quality”. (Barnard, 1999:265). Other legislation which supports the NWA is the *Water Services Act (Act 108 of 1997)* (WSA) and NEMA.

DWAF is responsible for water management in terms of the NWA and within the broader framework of other environmental legislation. “The National Water Resource Strategy (NWRS) is the implementation strategy for the NWA and provides the framework within which the water resources of South Africa will be managed in the future. All authorities and institutions exercising powers or performing duties under the NWA must give effect to the NWRS. This strategy sets out policies, strategies, objectives, plans, guidelines, procedures and institutional arrangements for the protection, use, development, conservation, management and control of the country’s water resources.” (DWAF, 2004:2.)

“The country has been divided into 19 Water Management Areas (WMAs). The delegation of water resource management from central government to catchment level will be achieved by establishing Catchment Management Agencies (CMAs) at WMA level. Each CMA will progressively develop a Catchment Management Strategy (CMS) for the protection, use, development, conservation, management and control of water resources within its WMA.” (DWAF, 2004:3.) Three of the WMAs fall within the Vaal River system.

DWAF also illustrated the integrated planning approach and relationship between national, provincial and local authorities with regard to the way in which resources are protected, used, developed, conserved, managed and controlled in Figure 2.4. (DWAF, 2004:3).

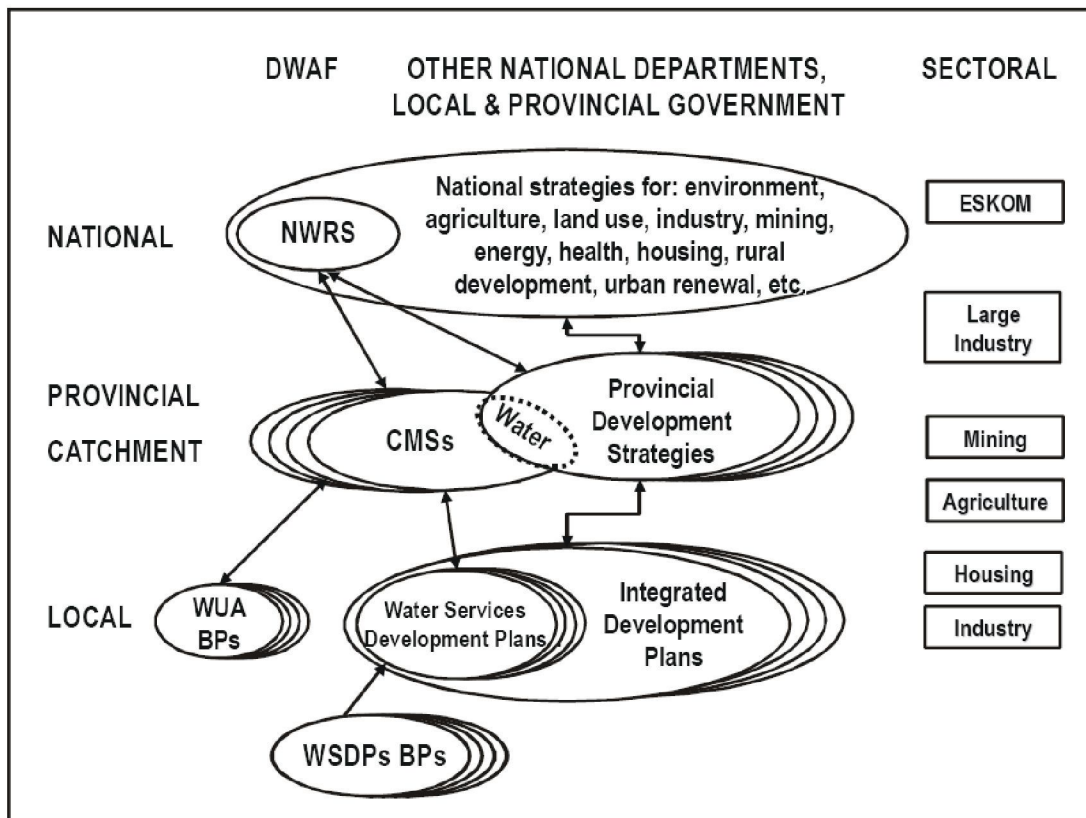

Figure 2.4: Integrated Planning Approach at Various Levels of Government in South Africa

(DWAf, 2004:3)

#### 2.2.3.4 Water Quality Management

Water availability is only as good as the quality of the water. In determining the best management practices for your facility, both the quantity and the quality of the water should be integrated in the water resource management.

The substances in water determine what it can be used for. A specific profile of users has over time been developed for water bodies such as dams, rivers or aquifers, because the water was suitable for use by these users. The set standard for the effluent disposed of into such water bodies is determined to ensure that the water remains suitable for other water users. For this purpose two aspects have to be determined: firstly the quality of the water and then the question whether the effluent could cause the water in the water body to be less effective for use. In order to apply the principle effectively, particulars of the different substances that can be found in water, the extent to which different percentages of these substances can affect the use that the water could be put to, and the tolerance of users to the substance in the water are required.

The Department of Water Affairs and Forestry embarked on a programme to re-evaluate

and develop its water quality management policies, which resulted in the *Water Quality Management Policies and Strategies in the RSA*, published in April 1991. (Barnard, 1999: 276). Applying the receiving water quality objectives, as was pointed out on page 14 of the 1991 policy involved “...the compilation of water quality guidelines based on the requirements of the recognised water uses ... (and the) ... formulation of water quality management objectives which recognise the water quality requirements of water users as well as economic, social, political, legal and technological considerations ... (and) ... site specific effluent standards or other measures to ensure that the water quality management objectives determined for the particular water body will be met ...” (DWAF, 1991:14).

The Department of Water Affairs and Forestry also developed the necessary water quality guidelines for different users: the domestic, recreational, industrial and agricultural users and aquatic ecosystems. The *South African Water Quality Guidelines* (WQGs) (DWAF, 1996), published in eight volumes, describe the acceptable level of substances for the different water users. The subcategories of industrial use include the use of water for cooling, steam generation, as process water, as production water and as utility water. The fitness of the water for use is evaluated according to its corrosiveness, scaling, fouling, forming of blockages, foaming, gas production, contamination, coagulation, turbidity, waste disposal and others. The constituents include its alkalinity, chemical oxygen demand, pH, chloride, iron, manganese, silica, sulphates and several others.

“Direct discharges to rivers are licensed and managed on the basis of assimilative capacities of those rivers, and on Receiving Water Quality. Where these limits are exceeded, often through the cumulative impact of diffuse discharges, water becomes unavailable to some, or even all, users downstream. DWAF will licence users to take water, and again to discharge it in recognition that there is generally a cost to the resource in terms of a reduction in quality and a reduction in its further assimilative capacity. It is for this reason, and in order to bring about additional management and a strong incentive, that the Waste Discharge Charge System is being developed. Discharge users will be obliged to pay, depending on the quantity and quality of their discharge.” (DWAF, 2004:12).

#### **2.2.3.5 Environmental Impact Assessments**

The Environmental Impact Assessment (EIA) process is required by law for new projects and significant extensions of existing projects in many countries. It covers a broad range of activities and introduces procedural elements such as the provision of an environmental impact statement and consultation with the public and environmental authorities, within the framework of development consent procedures for the activities covered. Without elaborating on the legislative progression of the impact assessments, a short explanation

would emphasise its importance.

Investigations conducted into the impact of specific projects on the environment are known as Environmental Impact Assessments (EIAs), Environmental Impact Reports (EIRs), Environmental Impact Statements (EISs), or planned analysis. In Strategic Environmental Assessments (SEAs) a region is assessed to determine its ability to adsorb impacts. In Integrated Environmental Management (IEM) the investigation forms part of management process.

The total EIA applications in South Africa since 1997 under the *Environmental Conservation Act 73 of 1989* (ECA) until July 1, 2006, were 43 423. This was a lengthy process and only 9% was finalised in 2 or more years, mostly because of complexity, controversy and delays in the review and decision making process. (Aucamp, 2006:107).

Since July 1, 2006 the Regulations fall under the NEMA (1998a):

- ✚ GN. R. 385 GG28753 of 21 April 2006
  - Environmental Impact Assessment Regulations, 2006,
- ✚ GN. R. 386 GG28753 of 21 April 2006
  - List of activities and competent authorities identified in terms of sections 24 and 24d of the NEMA, and
- ✚ GN. R. 387 GG28753 of 21 April 2006
  - List of activities and competent authorities identified in terms of sections 24 and 24d of the NEMA (Sections 27 - 36 apply) (Aucamp, 2006:38).

There are two types of assessments and an Environmental Assessment Practitioner (EAP) must determine the need and type of EIA from the lists provided in the Act:

- ✚ List A (GN. R. 386 GG28753 of 21 April 2006, Sections 22 - 26 apply)
  - Basic Assessment, and
- ✚ List B (GN. R. 387 GG28753 of 21 April 2006, Sections 27 - 36 apply)
  - Scoping, Plan of Study (PoS), Full EIA, SEA (Aucamp, 2006:38).

Refer to Figure 2.5 for a simplified typical process flow of the EIA process that came into effect on 1 July 2006.

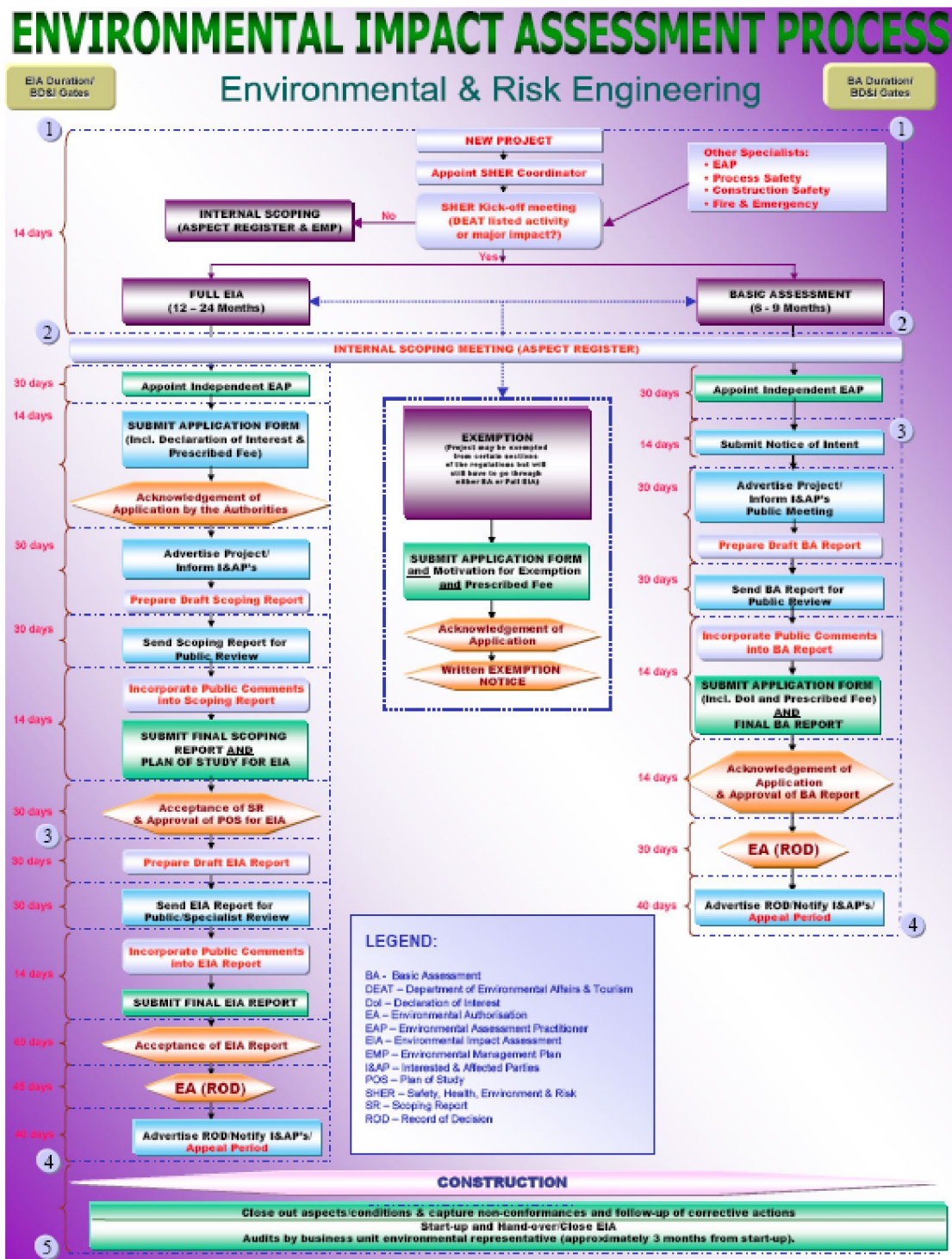

Figure 2.5: Environmental Impact Assessment Process

(Sasol, 2003)

In terms of the EIA Regulations, Section.29 (1) (b) feasible alternatives are required to be considered as part of the environmental investigations. An alternative in relation to a proposed activity refers to the different means of meeting the general purpose and requirements of the activity (as defined in GN.R.385 of the EIA Regulations, 2006), which may include alternatives to:

- ✚ the property on which or location where it is proposed to undertake the activity;
- ✚ the type of activity to be undertaken;
- ✚ the design or layout of the activity;
- ✚ the technology to be used in the activity; and
- ✚ the operational aspects of the activity.

The EIA process incorporates a public participation process where the primary aim is for all Interested and Affected Parties (I&APs) to participate in the decision making process. This process can only be successful if there is:

- ✚ meaningful and timeous participation of I&APs;
- ✚ promotion of transparency and an understanding of the proposed project and its potential environmental (social and biophysical) impacts;
- ✚ accountability for information used for decision making;
- ✚ service as a structure for liaison and communication with I&APs;
- ✚ assistance in identifying potential environmental (socio-economic and biophysical) impacts associated with the proposed development; and
- ✚ consideration of the needs, interests and values of I&APs in the decision making process.

The combination of the specialist studies into a consolidated report will allow for easy assessment of the potential environmental aspects. The criteria for the classification of impacts should be as per Regulation 32 of the EIA Regulations (July 2006) promulgated under the NEMA (1998a). In order to evaluate the significance of the identified impacts, the characteristics of each potential impact in Table 2.1 should be identified.

**Table 2.1: Characteristics of Environmental Impacts**

CATEGORY	DESCRIPTION OF DEFINITION
Cumulative Impacts	In relation to an activity, it means the impact of an activity that in itself may not be significant but may become significant when added to the existing and potential impacts eventuating from similar or diverse activities or undertakings in the area.
Nature	A brief written statement of the environmental aspect being impacted upon by a particular action or activity.
Extent (Scale)	The area over which the impact will be expressed. Typically, the severity and significance of an impact have different scales and as such bracketing ranges are often required. This is often useful during the detailed assessment phase of a

CATEGORY	DESCRIPTION OF DEFINITION
<ul style="list-style-type: none"> <li>✚ Site</li> <li>✚ Local</li> <li>✚ Regional</li> <li>✚ National</li> <li>✚ International</li> </ul>	<p>project in terms of further defining the determined significance or intensity of an impact. For example, high at a local scale, but low at a regional scale.</p> <ul style="list-style-type: none"> <li>✚ The immediate vicinity of the project (radius ±100 m)</li> <li>✚ Within a radius of 2 km of the project</li> <li>✚ Provincial (and parts of neighbouring provinces)</li> <li>✚ The whole of South Africa</li> <li>✚ Beyond the borders of South Africa</li> </ul>
<p>Status</p> <ul style="list-style-type: none"> <li>✚ Positive (+)</li> <li>✚ Negative (-)</li> <li>✚ Neutral</li> </ul>	<p>Denotes the perceived effect of the impact on the affected area.</p> <ul style="list-style-type: none"> <li>✚ Beneficial impact</li> <li>✚ Deleterious or adverse impact</li> <li>✚ Impact is neither beneficial nor adverse</li> </ul> <p>It is important to note that the status of an impact is assigned based on the <i>status quo</i> - i.e. should the project not proceed. Therefore not all negative impacts are equally significant.</p>
<p>Duration</p> <ul style="list-style-type: none"> <li>✚ Short-term</li> <li>✚ Medium-term</li> <li>✚ Long-term</li> <li>✚ Permanent</li> </ul>	<p>Indicates what the lifetime of the impact will be.</p> <ul style="list-style-type: none"> <li>✚ 0-5 years</li> <li>✚ 5-15 years</li> <li>✚ Impact will cease after the operational life of the activity</li> <li>✚ Permanent</li> </ul>
<p>Probability</p> <ul style="list-style-type: none"> <li>✚ Improbable</li> <li>✚ Probable</li> <li>✚ Highly probable</li> <li>✚ Definite</li> </ul>	<p>Describes the likelihood of an impact actually occurring.</p> <ul style="list-style-type: none"> <li>✚ Possibility of the impact materialising is very low</li> <li>✚ Distinct possibility that the impact will occur</li> <li>✚ Most likely that the impact will occur</li> <li>✚ Impact will occur regardless of any preventative measures (i.e. mitigation)</li> </ul>
<p>Intensity</p> <ul style="list-style-type: none"> <li>✚ Low</li> </ul>	<p>Describes whether an impact is destructive or benign</p> <ul style="list-style-type: none"> <li>✚ Impact affects the environment in such a way that natural, cultural and social functions and processes are not affected</li> </ul>

CATEGORY	DESCRIPTION OF DEFINITION
<ul style="list-style-type: none"> <li>✚ Medium</li> <li>✚ High</li> </ul>	<ul style="list-style-type: none"> <li>✚ Effected environment is altered, but natural, cultural and social functions and processes continue, albeit in a modified way</li> <li>✚ Natural, cultural and social functions and processes are altered to the extent that they temporarily or permanently cease</li> </ul>
Significance  <ul style="list-style-type: none"> <li>✚ Low</li> <li>✚ Medium</li> <li>✚ High</li> </ul>	The significance of an impact is determined through a synthesis of all of the above aspects.  <ul style="list-style-type: none"> <li>✚ No influence</li> <li>✚ Will have an influence</li> <li>✚ Will have an influence regardless of mitigation</li> </ul>

The suitability and feasibility of all proposed mitigation measures should be included in the assessment of significant impacts and mitigation measures should be identified.

## 2.2.4 Conclusion

In the Introduction it was mentioned that this section would emphasise why people should know about the legislation and the management of the environment. A reasonable thumbnail sketch to strengthen the importance of environmental legislation in the compilation of the BMPs to attain ZED can include the following:

- ✚ respect for nature;
- ✚ the interest of future generations;
- ✚ identification of feasible, environmentally friendly, alternatives;
- ✚ criminal liability, which can vary from fines, jail sentences, forced repair of damage to closing down of the company;
- ✚ civil liability;
- ✚ requirements and consequences of the EIA process; and
- ✚ making good business sense, considering the image of the company and the reputation with your customers.

## 2.3 Principles of Water Use Efficiency

### 2.3.1 Introduction

In the previous section the need for BMP frameworks due to the ever-increasing environmental legislation was the focus. The fact that South Africa depends upon sound

management of its water resources in order to be sustainable was also emphasised. This section look into the principles of water use efficiency, which concentrates on alternative uses for different quality water by different activities. Various dimensions of water management in literature boil down to the reduction of the amount of water in the various production processes, with the ultimate aim of ZED. Donald Tate (2000) illustrates how the term “water use efficiency” originates in the economic concept of productivity.

“Productivity measures the amount of any given resource that must be expended to produce one unit of any goods or service. Thus, for example, labour productivity in a steel mill would be the amount of labour required to produce a tonne of crude steel. In a similar manner, water productivity might be measured by the volume of water taken into a plant to produce a unit of the output. In general, the lower the resource input requirement per unit, the higher the efficiency. Throughout this book, improved water use efficiency in its simplest form means lowering the water needs to achieve a unit of production in any given activity.

“In an environmental resource context, however, the efficiency concept must be extended to include considerations of quality. Any effort to improve water use efficiency should be consistent with maintaining or improving water quality.” (Tate, 2000:1)

The importance of water use efficiency on sustainable development was high on the agenda of the 2002 World Summit on Sustainable Development (WSSD), where all countries were requested to produce Integrated Water Resource Management (IWRM) and water efficiency plans by 2005. (UNESCO, 2006:14). The Global Water Partnership (GWP) defines the IWRM as “a process which promotes the coordinated development and management of water, land and related resources in order to maximize the resultant economic and social welfare in an equitable manner without compromising the sustainability of vital ecosystems”. (UNESCO, 2006:14). Water governance is the key theme of the 2006 WWDR 2 which classifies the four dimensions of water governance as indicated by Tropp in Figure 2.6. (Tropp, 2005). Tate adds five basic parameters related to the physical dimension of water use efficiency as well as the technological dimension to the economic, social and environmental dimensions of water governance (Tate, 2000).

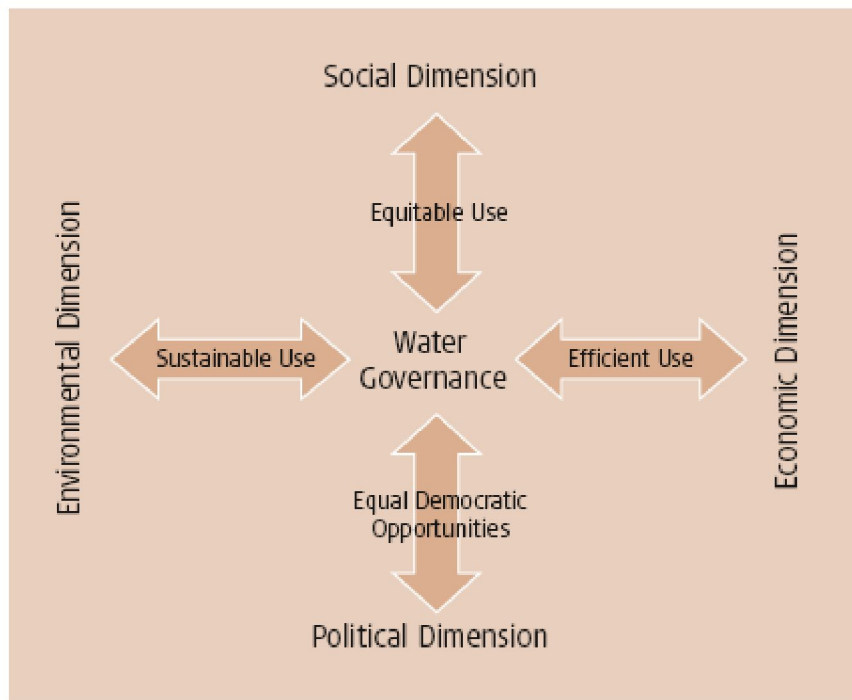

**Figure 2.6: Dimensions of Water Governance**

(Tropp, 2005)

This section examines the practices that should lead to improved water use efficiency to include as BMP frameworks in assessing various water supply and demand measurements. Important is the fact that water use management will differ between industrial activities and their location and industry should address all the options available to compile their unique framework to achieve water use efficiency, and ultimately aiming for ZED.

### 2.3.2 Water Use Efficiency in Industry

When water quality management was discussed earlier, the different ways water is used in industry was mentioned. Water is part of the raw material, a solvent and/or part of the final product; is used for transporting dissolved material, for heating, cooling, cleaning and steam generation in industrial processes. The surplus water at the end of the process, taking cognisance of evaporation and water trapped in products and other residual material as part of the water balance is normally discharged as effluent. The WWDR 2 indicates that the water withdrawal from surface water and groundwater by industry is usually much more than the amount of water that is actually consumed, as illustrated in Figures 2.7 and 2.8 (Shiklomanov, 2000). One of the key principles to reach ZED is the recycling or reusing of effluent before the final treatment. The quality of effluent in relation to the quality of water required by the different users is important. Tate (2000) supports the concept of WWDR 2 where higher water productivity and the final goal of ZED can be achieved through the allocation of water based on values of water in alternative uses. The next section will

briefly indicate the different strategies to increase water efficiency by selecting typical water use patterns in different activities at different locations.

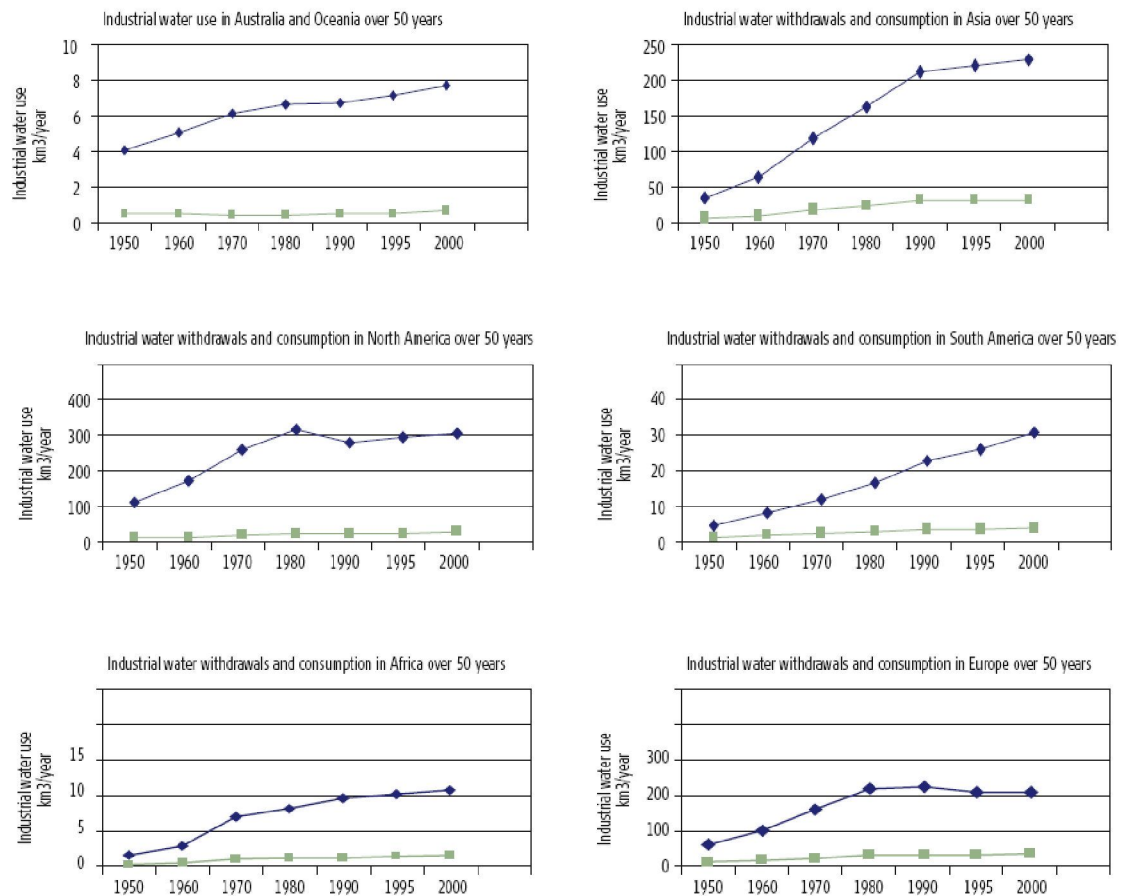

**Figure 2.7: Trends in Industrial Water Use by Region, 1950-2000**

(Shiklomanov, 2000)

**Note:** Vertical scale varies among the graphs. Industrial water withdrawals in Africa and South America are still rising, albeit of a very low base. In Asia, North America and Europe industrial water use accounts for the bulk of the global figure for industrial water withdrawals. Note that industrial water consumption everywhere is much lower than the volume of water withdrawn.

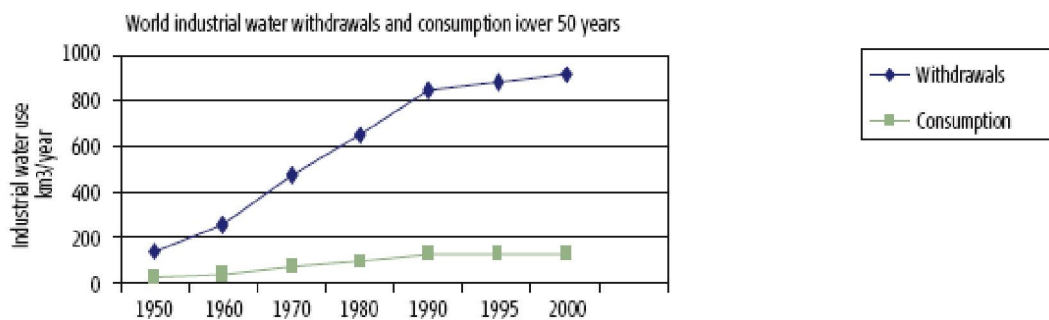

**Figure 2.8: Total World Industrial Water Use, 1950-2000**

(Shiklomanov, 2000)

### 2.3.3 Physical Dimension of Water Use Efficiency

The physical dimension of water management will always be the criterion which is relatively variable due to the variation in industry and facility specific requirements. In a semi-arid region such as South Africa, the need of BMPs for better water use efficiency is more important than in regions with surplus water. Where legislation or the economic situation prescribes the site specific requirements, the water use processes of an industry can be modified to comply with environmental requirements. The case studies in Chapter Three will also reflect in more depth on the physical and technological BMPs to reach ZED.

Tate categorises the water use cycle of any activity using five basic parameters:

- ✚ “Gross water use refers to the total amount of water used to carry out an activity, such as producing a manufactured product, doing a load of laundry, or growing a particular crop. It is composed of two basic sources:
  - intake, the amount of "new" water taken into the operation under consideration; and
  - recirculation, the amount of previously used water employed in the activity.
- ✚ Likewise, the two remaining parameters relate to the release side of the water use cycle:
  - discharge, the amount of water allowed to exit the activity or process; and
  - consumptive use, the amount used up during the process as steam, incorporation into product, or other means” (Tate, 2000:2).

For a ZED status the *discharge* parameter should thus equal zero.

The strategies to reduce water contamination and reuse of effluent to increase water use efficiency included in the WWDR 2 report and practised by numerous industries with the eventual objective of ZED, provide a good baseline for the framework developed in this dissertation. The principles of cleaner production can also be applied to reduce pollution.

#### 2.3.3.1 Cleaner Production

There are many case studies of cleaner production available to assist industries to be more profitable as well as cleaner, using a methodology called Cleaner Production Assessment (CPA). The methodology identifies areas of inefficient use of resources and poor management of wastes by focussing on the environmental impact of industrial processes. WWDR 2 summarises the five phases of this methodology:

**Phase I:** Planning and organization: obtain management commitment; establish a project team; develop policy, objectives and targets; plan the CPA.

**Phase II:** Pre-assessment (qualitative review): prepare company description and flow chart; undertake a walkthrough inspection; establish a focus.

**Phase III:** Assessment (quantitative review): collect quantitative data; assess material balance; identify Cleaner Production opportunities; record and prioritize options.

**Phase IV:** Evaluation and feasibility study: prepare preliminary evaluation; conduct technical evaluation; conduct economic evaluation; conduct environmental evaluation; select viable options.

**Phase V:** Implementation and continuation: prepare an implementation plan; implement selected options; monitor performance; sustain Cleaner Production activities” (UNESCO, 2006:294)

### **2.3.3.2 Water Mass Balance**

The principle of water use efficiency is to either lower the water input where it might be unnecessarily wasted or by identifying different users with different quality requirements and thus recycling and/or reusing the same effluent.

“Conducting a water audit of an industrial plant or manufacturing facility clearly shows where the water supplied to the plant is being used, how much is used in each process, and where it ultimately ends up. Rainwater that falls on the site, as well as the natural evaporation that occurs, should also be included in the audit. Once a water audit has been done, it is possible to draw a flow chart and show the water balance across the plant, or over individual units of the process. This is the first step in finding innovative ways to save water on an industrial site.” (UNESCO, 2006:290.)

### **2.3.3.3 Matching Water Quality to Use Requirements**

The importance of using a water mass balance effectively is to identify the quality of water required by a specific process. One of the biggest mistakes by many industries is to use unnecessary high quality water for the different processes where lower quality water would have sufficed. “Often 50 percent or more of an industrial plant’s water intake may be used for the purpose of process cooling, a need that can often be met with lower quality water. On the other hand, some industries require water of exceptionally high quality. In such processes, additional water treatment is carried out on the water received from the local water utility, or withdrawn from groundwater or surface waters, in order to further improve the water quality before it is used.” (UNESCO, 2006:290.)

Water of different qualities can be made available to different users by recycling and reuse of the waters in the water mass balance.

#### **2.3.3.4 Water Recycling and Water Reuse**

Water use efficiency is increased if less freshwater is used to manufacture the same amount of a basic product and water recycling and reuse is the essence to attaining this objective.

“Water recycling is the primary means of saving water in an industrial application: taking wastewater that would otherwise be discharged and using it in a lower quality application (often after treatment). Each cubic metre (m<sup>3</sup>) of water that is recycled on-site represents one cubic metre that will not have to be withdrawn from a surface water source or from groundwater. Water can even be used many times over. In such cases, where, for instance, a given cubic metre of water is used ten times in the process (a ‘recycle ratio’ of ten to one), this represents 9 m<sup>3</sup> that are not withdrawn from a freshwater source. Increased water savings can be made by raising the recycle ratio. The industrial water productivity of the product is thereby also greatly increased, as far less freshwater is used to produce the same quantity of product” (UNESCO, 2006:290-291.)

The most common applications that are used by nearly all types of industries are heating, cooling and quenching and these applications do not always require such high quality water.

“A second consideration in recycling industrial water is the cost of treating the wastewater to the required level, including the cost of new or additional pipes and pumps, as compared to the cost of ‘raw’ water supplies (freshwater). Where the quality of freshwater is declining locally, or where freshwater supplies are becoming unreliable due to water scarcity in the region (droughts or falling groundwater levels), on-site industrial water recycling becomes an increasingly attractive option. On-site water recycling can be regarded as a component of industrial risk management, since it contributes to reducing the risk related to the unreliability of freshwater supplies” (UNESCO, 2006:291.)

The WWDR 2 also includes the option of one industrial enterprise using the wastewater produced by another industrial plant. The innovative partnership in the Durban area where reclaimed water is supplied to industries is indicated in Table 2.2. Implementing ZED would ensure that once freshwater is used by industry, the water remains within the industrial cycle, and the fraction that evaporates in the process should be clean from contaminants and is in essence returned to the natural water cycle.

**Table 2.2: Innovative Reclaimed Water Partnership in the Durban Area**

“In the metropolitan region of Durban, South Africa, an innovative public-private partnership has been supplying reclaimed water to industries since 1999. The Southern Sewage Works of the Durban Metro Water Services treats over 100,000 m<sup>3</sup>/day of domestic and industrial effluent (through primary treatment only), prior to discharging it to sea through a long sea outfall. Projections showed that the capacity of the sea outfall would soon be reached, due to the growing population and industrial water discharges in the area. A secondary treatment plant with a capacity of 48,000 m<sup>3</sup>/day was built, which was allowed to discharge water into a canal that flows over the beach into the sea. A nearby paper mill then contracted to take 9,000 m<sup>3</sup>/day of the treated water. A local survey was undertaken, which found that further (tertiary) treatment would be required to sell reclaimed water to other industries in the area, which needed higher quality water than the paper mill. Since it was not economically feasible for the municipal water utility to construct and operate such a high-tech plant, the tertiary treatment works (which currently treat and sell up to 30,000 m<sup>3</sup>/day of reclaimed water to local industries) was built through a public-private partnership.”

(UNESCO, 2006:292)

### 2.3.3.5 Stream Separation

What seemed to be a good idea at the time of planning and construction of many industries, is now one of the headaches. The relative clean storm water and the various grades of contaminated effluents from the different processes were discharged into the same infrastructure before eventually being discharged into the receiving environment. It is important for new developments to carefully plan the discharge configuration during the different phases of the CPA described earlier to ensure a cleaner production process.

Various sources of literature confirm the importance of stream separation when identifying effluents for reuse and recycling and for assessing effluent that should be treated to acceptable levels before being discharged. The WWDR 2 also acknowledges the fact that effluents containing a variety of contaminants require more complicated and expensive treatment than effluents containing only one contaminant and also that mixing a concentrated stream of effluent with a more diluted stream may result in much larger volumes of effluent to be treated by an expensive treatment process.

“The diluted stream alone may be suitable for discharge directly into a sewer, to be dealt with by a municipal wastewater treatment plant or may be suitable for on-site recycling for direct reuse in another part of the process. Treating the concentrated stream alone may become easier, because it may contain fewer contaminants and is likely to be cheaper,

because the volume is much smaller. Now that a wide range of treatment technologies is available, stream separation may provide better and more cost-effective solutions in comparison to producing a single mixed effluent. The larger the enterprise, the more cost-effective this approach becomes. However, even small and medium-sized enterprises may benefit from considering stream separation” (UNESCO, 2006:297).

#### **2.3.4 Technological Dimension**

Technologies and in particular the improvement of technologies related to water management is important to ensure water use efficiency. In the past technology for the treatment of effluent was expensive but the cost is now being reduced and it is also available worldwide. Tate (2000) makes a distinction between the dimensions of technologies on the supply and demand side.

“On the supply side, the progression of technology has vastly increased the resources available, through the discovery of new reserves and stocks of everything from petroleum to fish. Supplies have been expanded even more by advances enabling the use of less accessible resources, of lower quality, and lesser concentrations.” (Tate, 2000:7.) If we simplify this to a manufacturing process, it relates well to the prevention of effluent contamination at source, a principle used by many industries to mitigate the requirement for a complicated and expensive effluent treatment system downstream.

“On the demand side, technology has progressively reduced and eliminated our dependence on particular resources for particular purposes, broadening the range and improving the suitability of materials available to producers.” (Tate, 2000:7.) The WWDR 2 confirms the importance of demand management. “Traditionally, the responses to pressures on water availability were solved by increasing supply: developing new sources and expanding and increasing abstractions from existing ones. As this is not sustainable, attention is switching rapidly towards more efficient and equitable approaches. The process of using water more efficiently and fairly, improving the balance between present supplies and demand, and reducing excessive use, is known collectively as demand management.” (UNESCO, 2006:14.)

Technological changes are thus required for water use efficiency. These technologies should be used to implement the required recycling, reuse and treatment of effluent before it is discharged into the neighbouring environment. There is a wide range of technologies available for effluent treatment (for example, settling, softening, clarification, flocculation, filtration, chlorination, reverse osmosis, adsorption, evaporation and crystallisation).

The report by the U.S Department of the Interior Bureau of Reclamation published a report in April 2008 (*Desalination and Water Purification Research and Development Program Report No. 149 - Evaluation and Selection of Available Processes for a Zero-Liquid Discharge System for the Perris, California, Ground Water Basin*). The report includes “a research of a wide range of existing and emerging water treatment technologies for the design and implantation of a ZED plant. Alternative processes such as secondary reverse osmosis (RO), electro dialysis reversal (EDR), forward osmosis (FO), membrane distillation (MD), and seeded RO (slurry precipitation and recycle reverse osmosis [SPARRO]) were studied by either bench-scale experiments or pilot plant testing. Subsequent brine minimization techniques, including brine concentrators (BC), crystallizers (XLZR), evaporation ponds, and SAL-PROCTM, were incorporated into the treatment processes; and overall economics were calculated through desktop modelling.” (US Department, 2008:1.)

The report is an excellent representative technical supplement to this BMP to attain ZED in the South African industry. Whereas this dissertation concentrates on management principles and not technologies to attain ZED, the mentioned report evaluates five technologies that, individually or in combination, could act as an intermediate brine treatment step to further concentrate the existing brine and recover more potable water at a lower cost. The report identifies and gives descriptions of the different technologies and processes. “There are several processes in various stages of development that could potentially treat brine from a primary desalting process to produce a zero-liquid discharge system.” (US Department, 2008:19.)

“A six-step approach was used to achieve the goals on this project.

Step 1 - Identify the potential processes

Step 2 - Develop operating criteria

Step 3 - Develop operating cost data

Step 4 - Develop capital cost estimates

Step 5 - Develop process combinations

Step 6 - Evaluate process combinations and select preferred alternative” (US Report, 2008:19).

Although the objective of this dissertation is to search for the management practices to attain ZED, the contents of the above mentioned report supports this dissertation from a technical perspective which falls outside the scope of the research. Due to the size of the report, only the table of contents of the report is attached as Appendix A for reference purposes.

### **2.3.5 Social Dimension**

The social dimension of water governance is of vital importance to industry although it has an indirect effect on the water use considerations. Social and political factors nowadays are much supported by the different regulations outlined earlier. Because of the subtle nature of these soft issues, as well as the differences and complexity thereof in different countries and regions, this section will not supply a framework available governing this aspect in detail. Tate calls the social dimension of water use efficiency socio-political factors, dealing with characteristics embedded in the fabric of societies. He supplies an illustrative observation of the application of this principle without being comprehensive or definitive.

Tate's discussion includes:

- a) the effects of social tastes and preferences,
- b) the effects of public education,
- c) some of the effects of the legal arrangements,
- d) the effects of property rights, and
- e) the effects of public policy." (Tate, 2000:5)

The effects of the complex legal arrangement and public policy were outlined earlier and the discussion that follows will deal briefly with Tate's other three principles.

#### **2.3.5.1 The Effects of Social Tastes and Preferences**

Tate is accurate in describing the major impact social tastes and preferences have on the way individuals and groups perceive the operations of industry and the need for water use efficiency. The social and cultural context of water is also visible throughout the different reports on water governance. Water is everyone's business and the key theme of the United Nations second World Water Development Report is water - a shared responsibility. The challenges of well-being and development are outlined in Chapters 6 to 9 of the WWDR 2 and the case studies included have a key theme of sharing resources. Discharging contaminated effluent in the environment has an enormous impact on people's lives and their development.

Despite the efforts by water governance bodies, industries' neighbouring communities organise themselves into forums and groups. In many instances these groups feel that the systems in place are not adequate and that the environmental legal, regulatory and administrative frameworks do not focus on the water quality requirement issues satisfactorily.

The important implication on the drive towards ZED is to involve all stakeholders in the

process. Tate (2000:6) points out that “deeply ingrained attitudes, tastes and preferences are important considerations in moving towards increased water use efficiency”.

### **2.3.5.2 The Effects of Public Education**

A fundamental principle to achieve acceptance of water use efficiency entails the education of the public. Chapter 13 of the WWDR 2 focuses on enhancing the knowledge base and the development of capacities to fill the void between the historic way of managing water and the desired sustainable water governance principles. People need to be educated in the effective management of water and also on the impact industry can have on the environment. The Millennium Development Goal no 8 requires the development of a global partnership.

The WWDR 2 concedes that “it is incumbent upon donor nations to embrace the new paradigm for water development by providing the necessary support (increased aid and debt relief, opening of trade, accelerated transfer of technology and improved employment opportunities) to allow developing nations to expand their knowledge base and enhance their existing local capacities rather than transferring short-term solutions as was common in the past. Likewise, it is the responsibility of the leaders of developing countries to create an enabling environment to enhance the existing local capacities and the knowledge base on water, by setting policies, ensuring adequate funding, and empowering local institutions and stakeholders with decision making responsibilities, and to monitor performance to ensure good governance and transparency”. (UNESCO, 2006:459).

The already mentioned international water related conferences and meetings provide a suitable platform for society to get exposure and also to enhance their knowledge from parties with similar experiences. As mentioned before, communities also embark on enhancing their knowledge by formulating groups and joining existing forums to get insight into the ideas of industry and the approaches of governing bodies with regard to the development of water governing structures. As discussed earlier, public education will have a direct effect on the attitudes of people and on water governance.

Some key sources included in the WWDR 2 for information on how to perform capacity assessments are included in Table 2.3.

**Table 2.3: Some Capacity Assessment Tools**

<p><b>The UNDP's Capacity Development Resource Book</b> (available at <a href="http://magnet.undp.org/cdrb/Default.htm">magnet.undp.org/cdrb/Default.htm</a>) is a collection of electronic documents assembled for capacity development practitioners.</p>
<p><b>UNDP website on capacity development</b> (<a href="http://www.capacity.undp.org/">www.capacity.undp.org/</a>) includes key sources for generic information on how to perform capacity assessments. Additionally, it includes initiatives, networks, resources and tools. It offers access to the Capacity 2015 initiative developed to operationalize the MDGs.</p>
<p><b>The South African Capacity Initiative (SACI)</b> (<a href="http://www.undp-saci.co.za">www.undp-saci.co.za</a>) developed a Capacity Mobilization Tool-kit for Southern African countries, which takes into consideration the particularly complex human capacity challenges associated with the impacts of HIV and AIDS, poverty and recurring disasters on sustaining basic social services to the public at all levels of the Millennium Development Goals.</p>
<p>The World Bank provides an online <b>Capacity Development Resource Centre</b>, which provides an overview of case studies, lessons learned, "how to" approaches and good practices pertaining to capacity development. It is available at <a href="http://www.worldbank.org/capacity">www.worldbank.org/capacity</a></p>
<p><b>The Canadian International Development Agency (CIDA)</b> has developed a Tool-kit for Capacity Development, available at <a href="http://www.acdi-cida.gc.ca/">www.acdi-cida.gc.ca/</a> that includes reference documents for capacity development.</p>
<p><b>The European Centre for Development Policy Management's Capacity Development</b> website (<a href="http://www.capacity.org">www.capacity.org</a>) aims to look at policy and practice of capacity development within international development cooperation and provides a newsletter and a comprehensive material related to capacity development in all sectors.</p>
<p><b>The International Development Research Centre (IDRC)</b>, the International Institute of Rural Reconstruction (IIRR) and the International Service for National Agricultural Research (ISNAR) implemented a project to better understand how capacity development takes place and how its results can be evaluated. Further information is available at <a href="http://www.idrc.ca/en/ev-31556-201-1-00-TOPIC.html">www.idrc.ca/en/ev-31556-201-1-00-TOPIC.html</a></p>
<p>A team of <b>The German Technical Cooperation (GTZ)</b> supported the Indonesian Government in preparing guidelines on how to organize and manage a capacity-building needs-assessment process in the regions, resulting in a medium-term regional capacity-building action plan. These very well structured guidelines, field-tested before they became final, are available at <a href="http://www.gtzsfdm.or.id/cb_nat_fr_work.htm">www.gtzsfdm.or.id/cb_nat_fr_work.htm</a></p>

(UNESCO, 2006:458)

### **2.3.5.3 The Effects of Property Rights**

The issue of property rights is a legal issue with water use as a key component. Industry should take cognisance of the property rights of the neighbouring community with regards to effluent discharge as well as seepage into underground systems. Tate points out that “water typifies common property resources, with non-exclusivity, non-enforceability and low prices. Under these conditions, little incentive exists for conserving, efficient resource use. Indeed, in many cases, the potential for overuse and abuse is strong, and management becomes a very complex and difficult undertaking. But the theory goes further by suggesting that externalities, under such conditions, will rise to socially unacceptable levels, and that, over time, the development of private or quasi-private arrangements of rights will develop. Currently, in some parts of the world, the development of water markets for re-allocating water supplies, and the fledgling use of effluent discharge fees and tradeable permits for pollution control reflect the growing reformation of property rights to water. Under such conditions, the development of increasingly efficient water use practices is an accompanying trend. The principle emerging here is that water use efficiency is partially a response to the property rights prevailing in a society”. (Tate, 2000:6).

### **2.3.6 Economic Dimension**

South Africa was previously classified as semi-arid which will result in competition for fresh water intake for use by industry. This will make water use efficiency critical and also the need for ZED more economically feasible.

The economic dimension, or in other words, the value of water, is one of the most important, but also one of the more difficult principles of water use and ultimately water use efficiency to quantify. The advantages and also the limitations of the different techniques used in the economic evaluation of water are important to all stakeholders. It plays a role in the decisions taken by policy makers, in the strategies chosen by industrial management, in the decisions by engineers responsible for designing plants and also for the public in expressing their personal tastes and preferences. Water governance must be a shared responsibility and everyone should be able to use the tools available.

Chapter 12 of the WWDR 2 Report discusses different mechanisms for the valuation and charging of water and also confirms the difficulty in attempting to value water. Throughout the report the role of the physical, social, cultural and economic factors are used concurrently and the same applies to the economic evaluation of water. Tate also confirms that many of the variables affecting water use are economic in nature. He

illustrates how three generalised factors of production, which are land, labour and capital, combine in considerable variations to yield products for consumption. (Tate, 2000:4). Similarly the WWDR 2 report classifies economic efficiency as “the importance of maximizing returns for the money, manpower and materials invested”. (UNESCO, 2006:406).

“The way in which the factors combine depends upon their relative prices. In other words, factor prices generally comprise indicators of how land, labour and capital will be combined to produce given products at given locations at specified times. Firms or consumers normally will tend to use relatively more of the cheaper inputs, and relatively fewer of the more costly ones. In economic theory, the optimal combination of inputs, or “economic efficiency”, occurs when the marginal prices of each of the factor inputs are equal. If any required input has a very low, or zero price, to the user, as much of that input will be used as required. Here lies one of the fundamental problems of environmental resource management.” (Tate, 2000:4.)

The predicament of industry is that water prices were historically low relative to the cost of the other two inputs and therefore the use of water was not managed effectively and water was used in abundance. Tate confirms that “when the price of an input such as water is very low relative to other productive inputs, it is used without regard for quantity or conservation ... This basic factor plays a major role in explaining why water usage per unit of production is high, why recycling rarely reaches its full potential and why water usage per capita is higher in some countries than in others”. (Tate, 2000:4). He concludes that low water prices are the enemy of water efficiency and uses the simple example that cheap or free water at plant inlets is cheaper than the installation of reticulation systems. “High intakes and low use rates are the logical outcome of low intake prices.” (Tate, 2000:4.)

Throughout Chapter 12 of the WWDR 2 report mention is made about the measurement of the values of water. The report also acknowledges that some values are difficult if not impossible to measure and that “informed decision relies upon such information developed largely through regular monitoring and data collection. Indicators which focus on critical aspects of water resources management and allocation have an important role to play in developing efficient and effective systems of water governance”. (UNESCO, 2006:428). The WWDR 2 report concluded that more water will be available for use by others if everyone contributes to the efficient use of the water in his system. The following economic indicators were included in the report and can be used as principles to determine the BMP for a specific industry:

- ✚ Opportunity cost is defined as the maximum worth of a good or input among possible alternative uses (OMB, 1992).

- ✚ Willingness to pay is the maximum amount an individual would be willing to pay, or give up, in order to secure a change in the provision of a good or service (OMB, 1992).
- ✚ Economies of scale are the savings achieved in the cost of production by larger enterprises because the cost of initial investment can be defrayed across a large number of producing units.
- ✚ Net present value (NPV) is the discounted or present value of an annual or periodic stream of benefits minus costs over the life of a project (OMB, 1992).
- ✚ The benefit-cost ratio (BCR) is the ratio of the present value of periodic benefits to the present value of periodic costs over the life of the project (Boardman *et al.*, 2000).
- ✚ Internal rate of return (IRR) is the discount rate that will render the present value of a future stream of net benefits equal to zero (OMB, 1992).
- ✚ Opportunity cost is the maximum worth of goods or input among possible alternative uses (OMB, 1992).
- ✚ “The ‘user pays’ principle contends that consumers should pay an amount equivalent to the burden (i.e. the full social cost) that their consumption places on society. Full social costs include both the capital, operating and maintenance expenditures to keep the system operating, and also the opportunity costs. They would also include the costs of damage resulting from the water pollution imposed on the society - the ‘polluter pays’ principle” (UNESCO, 2006:406).
- ✚ “Deductive methods involve logical processes to reason from general premises to particular conclusions. Applied to water valuation, the deductive methods commence with abstract models of human behavior that are fleshed out with data that is appropriate to projected future policy, economic or technological scenarios. Assumptions can be varied and the sensitivity of the results to varying assumptions can be determined. The advantages of deductive models are simplicity, flexibility and the ability to analyze a hypothesized future. In principle, they can incorporate alternative assumptions about prices, interest rates and technology, thus testing the projections about unknown, future conditions” (UNESCO, 2006:407).
- ✚ “Inductive methods, on the other hand, involve a process of reasoning from the particular to the general, that is, from real-world data to general relationships. Observations on water-user behavior are tabulated and subjected to formal statistical analysis to control for external factors influencing willingness to pay” (UNESCO, 2006:407-409).

“The Millennium Ecosystem Assessment (2005) report forcefully reiterates the importance of considering environmental and ecosystem values. The economic significance of anticipating and avoiding environmental damages becomes apparent when one considers the costs of remediation, not to mention the social costs” (UNESCO, 2006:407-408). Table

2.4 was used as example to illustrate the high cost of restoring a clean water source in a selected sample of cities across the United States and should be useful in identifying the cost associated with different types of problems that industries may experience and need to address to reach the goal of ZED. (UNESCO, 2006:408).

**Table 2.4: The high Cost of Coping with Source Water Pollution in selected Communities in the US**

Community	Type of problem	Response	Costs (USA)
Perryton, Texas Camden-Rockland, Maine	Carbon tetrachloride <sup>1</sup> in groundwater Excess phosphorus in Lake Chickawaukie	Remediation	\$250,000 (estimated)
Moses Lake, Washington	Trichloroethylene <sup>2</sup> in groundwater	Blend water, Public education	\$1.8 million (to date)
Mililani, Hawaii	Pesticides, solvents in groundwater	Build and run treatment plant	\$2.5 million + \$154,000/yr
Tallahassee, Florida	Tetrachloroethylene <sup>3</sup> in groundwater	Enhanced treatment	\$2.5 million + \$110,000/yr
Pittsfield, Maine	Land-fill leachate in groundwater	Replace supply, remediation	\$1.5 million (replace supply)
Rouseville, Pennsylvania	Petroleum, chlorides in groundwater	Replace supply	> \$300,000 (to date)
Atlanta, Missouri	Volatile Organic Compounds (VOCs) <sup>4</sup> in groundwater	Replace supply	\$500,000 to \$600,000
Montgomery County, Maryland	Solvents, freon <sup>5</sup> in groundwater	Install water lines, provide free water	\$3 million + \$45,000/yr for 50 years
Milwaukee, Wisconsin	Cryptosporidium <sup>6</sup> in river water	Upgrade water system; immediate water utility; Health Department Costs	\$89 million to upgrade system; millions in immediate costs
Hereford, Texas	Fuel oil groundwater	Replace supply	\$180,000
Coeur d'Alene, Idaho	Trichloroethylene <sup>2</sup> in groundwater	Replace supply	\$500,000
Orange County, California	Nitrates, salts, selenium, VOCs in groundwater	Remediation, enhanced treatment, replace supply	\$54 million (capital costs only)

Note: This table features a sampling of localities of various sizes that bore high, readily quantifiable costs due to source water pollution. It attempts to isolate community costs, excluding state, federal and private industry funding. Not included here are the costs to individuals, such as lost wages and medical costs, reduced property values, higher water bills, and, in extreme cases, death.

1. A manufactured chemical most often found in the air as a colorless gas, used in the production of refrigeration fluid and propellants for aerosol cans, as a pesticide, as a cleaning fluid and degreasing agent, in fire extinguishers, and in spot removers; soluble in water.
2. A colorless or blue organic liquid with a chloroform-like odor used as a solvent to remove grease from fabricated metal parts and some textiles.
3. A manufactured chemical used for dry cleaning and metal degreasing. Exposure to very high concentrates can cause dizziness, headaches, sleepiness, confusion, nausea, difficulty in speaking and walking, unconsciousness, and death. See also: [www.atsdr.cdc.gov/tfacts18.html](http://www.atsdr.cdc.gov/tfacts18.html)
4. Volatile organic compounds; for more information see: [glossary.eea.eu.int/EEAGlossary/N/non-methane\\_volatile\\_organic\\_compound](http://glossary.eea.eu.int/EEAGlossary/N/non-methane_volatile_organic_compound)
5. FREON (trade name) is any one of a special class of chemical compounds that are used as refrigerants, aerosol propellants and solvents.
6. Parasitic protozoa found in soil, food, water, or surfaces that have been contaminated with infected human or animal feces.

(UNESCO, 2006:408)

### 2.3.7 Environmental Dimension

Industrial pollution has a direct effect on the deteriorating quality of water in many rivers and marine environments. Achieving a ZED status will be a foremost contribution to a cleaner environment for everyone to live in. Water and water governance through sustainable development of water uses have a major role to play in achieving the Millennium Development Goals (MDGs) by 2015. The different principles of water use efficiency outlined earlier in this section presented several dimensional views of water use efficiency. Tate correctly portrayed the environmental aspect in contrast, “the environmental aspect encourages us to take a somewhat broader view of the issue, and to realize the need for integrated approaches to management. This is where water quality considerations ... become important. For instance, conceptualizing efficiency as an input-output issue, as was done at the outset of the chapter, leads to concentration on the quantitative aspects of water use” (Tate, 2000:7).

### 2.3.8 Conclusion

It is important to take the different principles for effective water use into account when developing BMPs to attain ZED in the South African industry. The framework to be formulated should be evaluated against numerous criteria, and this section provided insight into establishing key principles for compiling the BMP framework.

## **2.4 Conclusion**

Chapter Two presented an overview of the environmental legislative requirements and the BMPs of water use efficiency that should be included when deciding on a framework to attain a ZED status. Although the framework should have a holistic approach, this chapter discussed some of the principles in isolation. Chapter 3 will focus on two case studies where the application of these BMPs is demonstrated.

## **CHAPTER 3 LITERATURE STUDY: CASE STUDIES**

### **3.1 Introduction**

The principles discussed in Chapter Two should be adopted for effective effluent management when confronted with effluent discharge restrictions and ultimately ZED. The selection and application of these principles in industry are important to ensure sustainable operation of manufacturing processes. Chapter Three consists of two case studies that describe effluent management and BMPs in two industries. The principles in Chapter Two and the application of the principles as summarised in this chapter, constitute the foundation for the framework to attain ZED in the South African industry. This framework is reported in Chapter Four.

### **3.2 Case Study - Effluent Management for a Metal Finishing Industry aiming at Zero Discharge Conditions**

#### **3.2.1 Introduction**

The study evaluates operational and technical implications of ZED conditions for a large metal finishing plant as a representative case study for the BMPs. “The plant is located within the protection zone of a surface water body designated as a potential source for consumption water supply. The study covers and provides the necessary information on the technical steps required for a comprehensive survey, involving detailed process profile, water demand, and wastewater generation, wastewater segregation for optimum treatment, water balance and conceptual basis of wastewater recycling. The selected effluent management strategy and the wastewater reuse scheme are defined. The non-recoverable portions of the wastewater, inherently generated as part of the treatment schemes are identified.” (Babuna, *et al.*, 2006:1794.)

These operational conditions of the industry in this case study include various synergies (due to the discharges associated with metal finishing) with the Mittal Steel case study that is measured against the framework developed in Chapter Four.

#### **3.2.2 Description of the Industry and Production Processes**

“The industry under investigation is established on an area of 1 005 000 m<sup>2</sup>, functions 5 days a week, employing 3 211 personnel. As the plant is located within the protection zone of a complex surface water resource system designed for multi-purpose beneficial uses, mainly involving abstraction for human consumption, it is permitted for no wastewater discharge. In other words due to the type of the permit, total recovery and reuse of

wastewater generated in the plant, is required. Four main production lines, namely; steel wheel production, tractor production, engine assembly shop and spring production are involved in the plant.” (Babuna *et al.*, 2006:1794.)

### 3.2.3 Water Consumption and Quality Requirements for Various Water Uses

“Throughout the plant water is used not only for the production processes and domestic purposes (water supply for workers and personnel), but also as cooling water make-up and boiler water make-up. The total daily water requirement of the installation may be calculated as 1 307 m<sup>3</sup> d<sup>-1</sup>, when boiler water demand is not considered.” (Babuna *et al.*, 2006:1796.)

“Generally there is a lack of scientific basis for setting the appropriate quality criteria for water consumption in industrial applications. Thus, specific demands of the manufacturer based upon practical experience become the decisive factor in defining the water quality requirements. Apart from irrigation, three different water quality requirements are set by the manufacturer i.e., for fresh cooling water inputs and for process waters either deionised or other types. Table 3.1 summarizes the relevant quality requirements for different types of water uses in the installation under investigation. As may be noted from the table, total dissolved solids, (TDS), either directly measured or expressed in terms of conductivity level is the sole quality parameter considered, with the assumption that water will be free of all other organic and/or particulate impurities. The specified conductivity level varies in a wide range from 10 to 2 000 µS cm<sup>-1</sup>, depending on the type of particular use.” (Babuna *et al.*, 2006:1796-1797)

**Table 3.1: Quality Requirements for Different Water Uses in the Plant**

Water quality for	TDS (mgL <sup>-1</sup> )	Conductivity (µS cm <sup>-1</sup> )
Irrigation		
✚ Class III (suitable)	525 - 1400	750 - 2 000
✚ Class IV (special care is needed)	1 400 - 2 100	2 000 - 3 000
Fresh Cooling Water	<450	<600
Process Water		
✚ Deionised	-	<10
✚ Other	-	<300 - 400

(Babuna *et al.*, 2006:1796-1797)

### 3.2.4 Wastewater Generation and Different Types of Process Wastewaters

“Process wastewaters of 425 m<sup>3</sup> d<sup>-1</sup> together with a cooling water discharge of 112 m<sup>3</sup> d<sup>-1</sup> and a domestic effluent of 385 m<sup>3</sup> d<sup>-1</sup> are generated in the plant. A conventional wastewater characterization is conducted on all effluent streams originating from different production processes to find out distinct quality differences. The observed quality differences are then evaluated in a way to collect and treat the wastewater streams with similar characteristics separately as part of an optimal recovery and recycle strategy. Within the context of this fact, process wastewaters are segregated to identify five different effluent streams, namely cutting oil wastewaters; dye containing wastewaters; oily wastewaters; general wastewaters; metal containing wastewaters.” (Babuna *et al.*, 2006:1798.)

“It must be noted that both continuous as well as intermittent wastewater discharges are generated from the production processes. The frequency of discharges from intermittent sources varies in a wide range of 2 days to 6 months.” (Babuna *et al.*, 2006:1798-9.) The characterisation of segregated wastewater streams in terms of relevant pollutant parameters is tabulated in Table 3.2

### 3.2.5 Treatment Requirements

“On the basis of specific water quality requirements, treatment to be prescribed for the recovery and reuse of the wastewater should remove all pollutant inputs associated with the manufacturing processes and lower the TDS level to a level acceptable for the respective water demand. In this context, the following preliminary treatment schemes are proposed for process wastewaters, according to the results of a treatability study, not reported in this paper: (i) Cutting oil wastewaters: Ultrafiltration + Evaporation, (ii) Dye containing wastewaters: Phase Separation + Chemical Precipitation + Biological Treatment, (iii) Oily wastewaters: Dissolved Air Flotation + Chemical Precipitation + pH Adjustment + Biological Treatment, (iv) Metal containing wastewaters: Chemical Precipitation + pH Adjustment, and (iv) General wastewaters: pH Adjustment + Biological Treatment. After the preliminary treatments specific for each wastewater stream, an advanced treatment unit to meet the process and cooling water requirements within the context of total recovery and recycle concept is installed for all wastewater streams.” (Babuna *et al.*, 2006:1800-1801.) The full treatment system (preliminary + advanced) envisaged for segregated process wastewaters is schematically illustrated in Figure 3.1.

**Table 3.2: Characterisation of Segregated Streams**

		Metal Containing wastewater		Oily wastewater		General wastewater		Dye containing wastewater
Parameter	Unit	Continuous	Intermittent	Continuous	Intermittent	Continuous	Intermittent	Intermittent
pH	-	6.41	6.44	9.48	10.35	9.97	8.52	7.1
COD	(mgL <sup>-1</sup> )	60	<30	200	2510	45	175	1 575
TSS	(mgL <sup>-1</sup> )	150	125	420	680	30	315	105
Oil & Grease	(mgL <sup>-1</sup> )	N.D.	N.D.	25	430	<10	<10	N.D.
Conductivity	(µScm <sup>-1</sup> )	1 850	2 600	2 500	10 000	1 300	6 500	5 300
Zinc	(mgL <sup>-1</sup> )	56.0	4.0	N.D.	N.D.	0.1	1.2	0.45
Total Iron	(mgL <sup>-1</sup> )	1.0	5.8	N.D.	N.D.	0.2	2.2	4.2
Ni	(mgL <sup>-1</sup> )	17.3	1.0	N.D.	N.D.	<0.2	0.3	<0.2
Total Cr	(mgL <sup>-1</sup> )	N.D.	N.D.	N.D.	N.D.	<0.5	<0.5	<0.5
Cd	(mgL <sup>-1</sup> )	N.D.	N.D.	N.D.	N.D.	N.D.	N.D.	<0.2
Cu	(mgL <sup>-1</sup> )	N.D.	N.D.	N.D.	N.D.	N.D.	N.D.	<0.5
Fluoride	(mgL <sup>-1</sup> )	18.0	12.0	N.D.	N.D.	0.5	3.0	N.D.

(Babuna *et al*, 2006:1798-9)

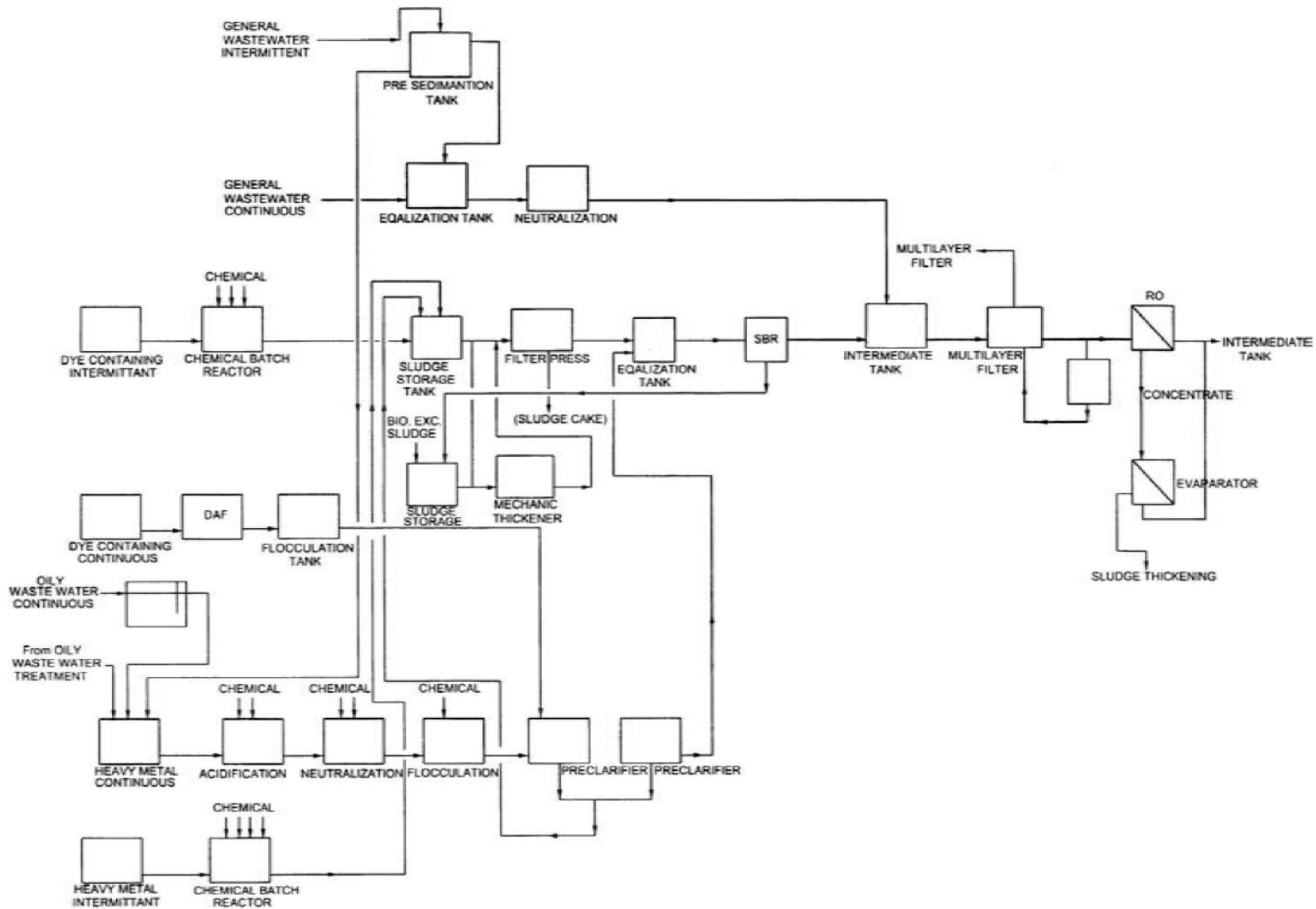

Figure 3.1: Schematic Process Diagram for Process Wastewater Streams

(Babuna *et al.*, 2006:1800-1801)

### 3.2.6 Water Balance

“The following key issues are considered while defining the appropriate water balance for recovery and reuse:

- i. The water requirement for contact domestic usage is supplied from tap water.
- ii. Treated cooling water discharge is primarily used to meet the cooling water requirement.
- iii. In summer and favourable weather conditions, the treated domestic wastewater is used for irrigation, after passing through biological treatment, filtration and subsequent disinfection.
- iv. In all other periods (winter conditions), the effluent of the domestic wastewater treatment plant is directed to the central advanced treatment facility for recovery and reuse in plant operations. This treated wastewater is used primarily as process water, then as cooling water input and finally as deionised process water.
- v. A portion of the treated domestic effluent is directly used in non-contact facilities such as toilet flushing.” (Babuna *et al.*, 2006:1800-1802.)

“The water balance defined for summer conditions, which entails favourable weather conditions, is outlined in Figure 3.2. Two significant factors must be envisaged for establishing water balance and evaluating the concept of zero discharge. The first factor relates to water losses associated with in-plant activities, due to evaporation, transportation, etc. These losses are calculated to vary, as shown in Table 8, from around 10% for process water to 75% for cooling water.

“The second factor involves losses associated with the treatment of the generated wastewater flows, as evaporation, formation of sludge and/or brine, etc. For the specific treatment scheme designed for the plant in this study such losses were evaluated. On the one hand these losses are quite important in setting the correct balance between recovery and demand and on the other hand, they challenge the validity of the zero discharge concept. In fact, a careful look at the reclamation system advocated for the plant would show that 90 m<sup>3</sup> d<sup>-1</sup> of untreatable residues, mostly in liquid form (brines), have to be disposed of from the plant premises, not perhaps to adjacent receiving waters, but to authorized sites for final disposal. This situation requires an in-depth review of the zero discharge concept which finally consists of dealing with TDS disposal and this parameter may be quite acceptable in the environment when there is acceptable proof that it may be safely diluted either on site or else at the final receiving medium. These observations seem to provide the basis for changing the conventional understanding of zero discharge towards a much more meaningful and manageable zero pollutant discharge concept.” (Babuna *et al.*, 2006:1802.)

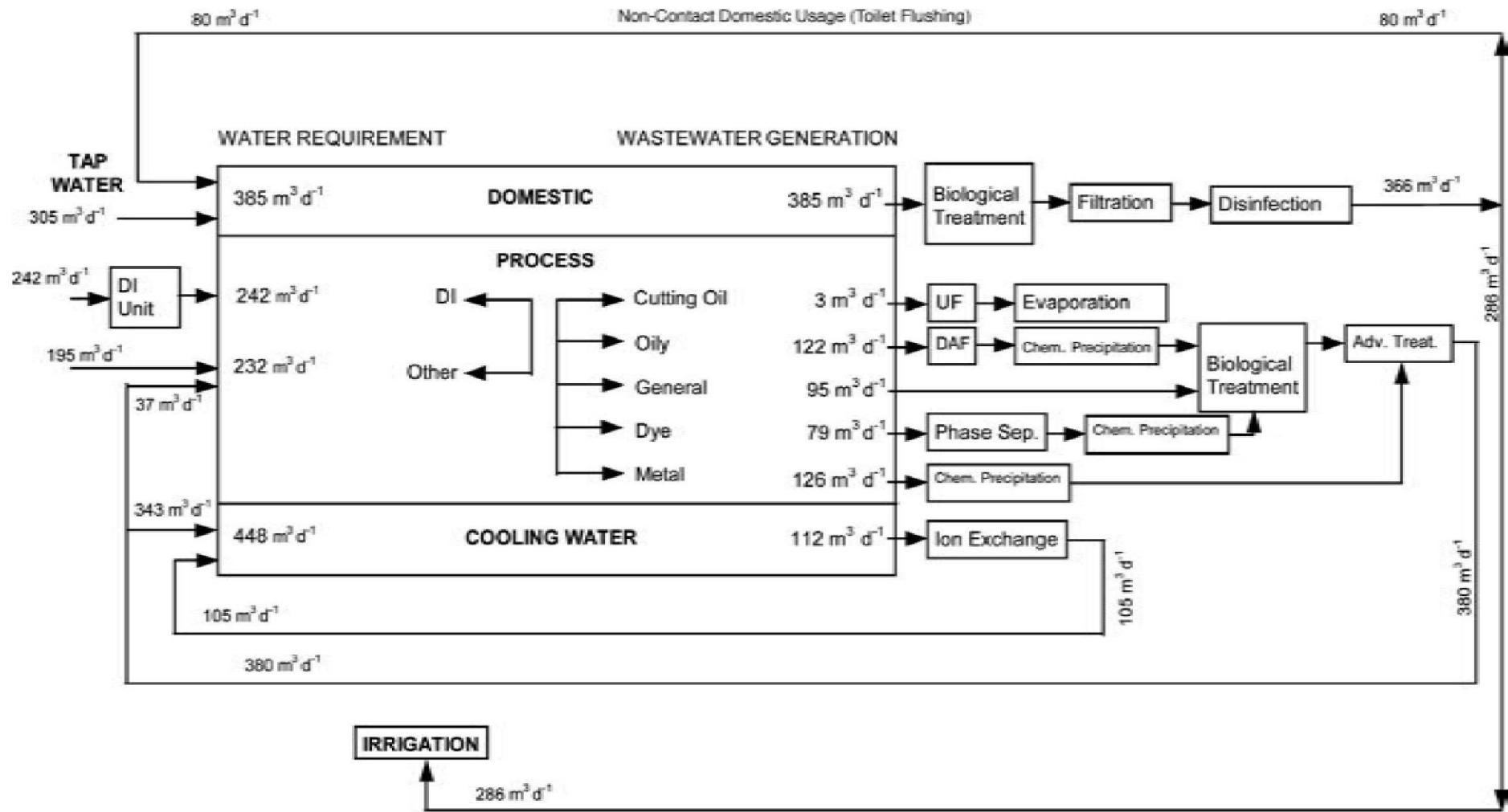

Figure 3.2: Water Balance for Summer and Favourable Weather Conditions

(Babuna *et al.*, 2006:1800-1801)

### 3.2.7 Conclusion

The case study indicates the use of some of the BMPs to attain ZED in industry and also how the evaluation of wastewater management drastically changes for total recovery and recycles and involves the total dissolved solids as the significant parameter. This work gives excellent practices to address preventative pollution measures. The researcher therefore decided to use the principles as base for the BMPs to attain ZED in the South African industry. The core of this case study is that the concept of ZED needs to be formulated in terms of the most important pollutants of concern and implemented accordingly. Chapter Four will make use of pattern-matching and address the most significant aspects of this case study to arrive at a holistic approach in developing the BMP framework for the South African industry.

## 3.3 Case Study - Best Management Practices: Marine Products Processing

### 3.3.1 Introduction

The case study presents a guide that was established to address marine products processing activities in the gulf region of Canada. Many of these plants are located in rural areas and this industrial activity is a significant aspect of the economy of the province. Similar to many industries in South Africa, the processing of marine products requires large volumes of water in the total process, which is also an increasingly limited resource in the province and whose cost could increase in the future. The significance of this case study to the compilation of the BMPs to attain ZED in the South African industry is amplified due to this and other similar challenges faced by the marine products processing industry. The case study illustrates the benefits that industrial plants can gain in both their economic as well as environmental performance, by adapting the BMP frameworks for the raw product, water and effluents.

“The use of large volumes of water, in addition to causing a significant loss of raw product, has as a direct consequence the generation of large volumes of effluents. These effluents can be particularly rich in residual organic matter (fats, protein). Furthermore, their characteristics can be quite variable from one plant to the other, because they are closely linked to the different types of production. The discharge of these effluents, in harbours and bays, remains a constant source of concern in terms of environmental impact and public health.” (Tchoukanova, *et al.*, 2007:2-3).

The Canadian industry will therefore also experience the tightening of environmental standards to which operating plants would be forced to operate. Industry will therefore “soon have to adopt best management practices (BMPs) aimed at better controlling the

quantity of water used as well as that of effluents generated in plant, and/or to equip themselves with technologies to treat effluents that are adapted to both their needs and their budget.” (Tchoukanova *et al.*, 2007:3).

It should be noted that this case study concentrates on the implementation of BMPs for the raw product, water and effluents of processing plants, and that it will not deal with technologies for the treatment of effluents.

### **3.3.2 Description of the Industry, Production Processes and Organic Pollution**

“In 2002, the 133 seafood plants having a processing permit issued by the Provincial Department of Agriculture, Fisheries and Aquaculture processed slightly more than 103,000 metric tons of marine products and the exports have reached a value of nearly 900 million dollars. Most of these plants are located in rural areas, where they provide work to thousands of local residents. The size and mode of operation of these processing plants vary considerably. Some plants are seasonal while others operate all year long. Some plants process large volumes of marine products, others process more modest volumes. Some plants process more than one marine species whereas others orient their activities towards a sole species.” (Tchoukanova *et al.*, 2007:2.)

“Marine products processing involves many steps and the use of large volumes of potable water. During the various steps required for such processing, mechanical action as well as water act vigorously on the raw product, thus forming an effluent containing raw product particles in a wide range of sizes. These particles, called Total Solids (TS), are classified according to their size and their solubility as Total Suspended Solids (TSS) or Total Dissolved Solids (TDS)” (Tchoukanova *et al.*, 2007:3.)

### **3.3.3 Environmental Regulations**

Chapter Two explored the environmental legislation for South Africa and therefore this section will only summarise the Canadian state of affairs. It was mentioned in the Introduction that environmental regulations will be strengthened due to the increasing deterioration of the quality of Canada’s coastal waters. There are currently no environmental regulations in Canada that are specifically related to the discharge of effluents from marine products processing plants, except for guidelines on pollution prevention which do not constitute legal requirements. “They are rather guidelines that aim at alleviating some of the common problems linked to the discharge of these types of effluents, by reducing the incidence of these problems to a level that reflects the use of good industrial practices by the processing plant.” (Tchoukanova *et al.*, 2007:10.)

Although the case study treats the subject quite vigorously, it did so from a Canadian regulatory perspective. As is evident from the problem statement in Chapter 1, this dissertation investigates the ZED requirements for South African industries. Similar to the challenges faced by the Canadian industries, the necessity for BMPs is fundamental to mitigate the effect of effluents being discharged into the South African receiving environment.

### 3.3.4 How to Measure Organic Pollution

In the BMP frameworks for the marine products processing, the first requirement is to analyse the composition of the effluents generated by the processing plant in order to estimate the degree of organic pollution. These analyses are done to provide the physical and chemical (i.e. physicochemical) characteristics of the effluents. The following approach, as described by Tchoukanova, *et al.*, illustrates the essential steps industry should carry out in order to measure this pollution.

#### ***Step 1: Measurement of the volume of effluents generated:***

Measure the total volume of effluents generated by the process per unit of time. These measurements will make it possible to determine the volume of effluents generated by the processing of one kilogram of raw product or by the production of one kilogram of finished product. (Tchoukanova *et al.*, 2007:6).

#### ***Step 2: Physicochemical characterisation of the generated effluents:***

Several analyses must be carried out to obtain the major physicochemical characteristics of an effluent discharged by industry. The following description was included for the marine products processing industry but is a good illustration of the important constituent of a composite effluent sample in a majority of industries.

**“Ammonia (NH<sub>3</sub>):** This is a measure (in mg/L) representing the quantity of ammonia contained in an unfiltered sample of effluents, and resulting from the bacterial decomposition of proteins.

**Fats, Oils and Greases (FOG):** This is a measure (in mg/L) representing the quantity of fatty matter (fats, oils and greases) contained in an unfiltered sample of effluents.

**Organic matter:** Organic matter is a generic term which includes all the various biodegradable compounds (fats, proteins, sugars, etc.) coming from animal and plant tissues.

**pH:** This is a measure of the acidity or the alkalinity of a sample. The pH varies along a

scale of 1 (highly acidic) to 14 (highly alkaline), with 7 as a neutral point.

**Total Biochemical Oxygen Demand ( $BOD_{5\text{ Total}}$ ) and Soluble Biochemical Oxygen Demand ( $BOD_{5\text{ Soluble}}$ ):** These are measures (in mg/L) that indicate the quantity of oxygen necessary for the degradation of the organic matter contained in an unfiltered ( $BOD_{5\text{ Total}}$ ) or filtered ( $BOD_{5\text{ Soluble}}$ ) sample of effluents by aerobic bacteria maintained under defined conditions during a 5 day period.

**Total Chemical Oxygen Demand ( $COD_{\text{ Total}}$ ) and Soluble Chemical Oxygen Demand ( $COD_{\text{ Soluble}}$ ):** These are measures (in mg/L) that indicate the quantity of oxygen necessary for the degradation of the organic matter contained in an unfiltered ( $COD_{\text{ Total}}$ ) or filtered ( $COD_{\text{ Soluble}}$ ) sample of effluents, by a chemical product reacting under defined conditions. The determination of the COD is faster than the determination of the BOD (the results can be obtained a few hours after the laboratory receives the sample). It is therefore used more often to estimate the level of organic contamination of effluents. There is a correlation between COD and BOD; typically the COD value will be somewhat higher than BOD, for a given sample.

**Total Nitrogen or Total Kjeldahl Nitrogen (TKN) and Total Soluble Nitrogen or Total Soluble Kjeldahl Nitrogen ( $TKN_{\text{ Soluble}}$ ):** These are measures (in mg/L) that represent the quantity of nitrogen (chemical symbol N) contained in an unfiltered (TKN) or a filtered ( $TKN_{\text{ Soluble}}$ ) sample of effluents. This nitrogen comes from the organic matter which is part of the Total Solids (TS) present in the effluent of a marine products processing plant.

**Total Phosphorus ( $P_{\text{ Total}}$ ) and Soluble Phosphorus ( $P_{\text{ Soluble}}$ ):** These are measures (in mg/L) that represent the quantity of phosphorus contained in an unfiltered ( $P_{\text{ Total}}$ ) or filtered ( $P_{\text{ Soluble}}$ ) sample of effluents. The phosphorus can originate from the decomposition of organic solids, food additives authorised for the process, and cleaning products.

**Total Dissolved Solids (TDS) :** This is a measure (in mg/L) of the solids of very small size present in a sample of effluents that pass through a standard glass fibre filter during the filtration.

**Total Suspended Solids (TSS) :** This is a measure (in mg/L) of the solids present in a sample of effluents and retained by a standard glass fibre filter during the filtration.

**Total Solids (TS) :** This is a measure (in mg/L) of all the TSS and TDS present in a sample of effluents.” (Tchoukanova *et al.*, 2007:7-9.)

### ***Step 3: Estimation of the quantity of pollutants produced***

“Estimate the quantity of TSS for an hour or a day of production by means of the following formulae:

$$TSS_{(Kg/hr)} = [TSS_{(mg/L)} \times TVEf_{(L/hr)}] / 1,000,000$$

or

$$TSS_{(Kg/day)} = [TSS_{(mg/L)} \times TVEf_{(L/day)}] / 1,000,000$$

These same formulae will also enable you to estimate the quantity of TKN, FOG, P, and  $NH_2$  discharged, as well as the BOD (COD) required, by hour or by day of production.” (Tchoukanova *et al.*, 2007:9-10.)

### 3.3.5 Best Management Practices

Similar to the metal finishing industry case study, the significance of preventative measures to prevent pollution, and the implementation of BMPs to achieve the required discharge standards are of importance in the marine products processing industry. The guide for BMPs of raw products, water and effluents for the marine products plants in New Brunswick in Canada consists of a series of procedures to:

- ✚ “reduce the volume of potable water used.
  - ✚ reduce the volume of effluents discharged.
  - ✚ reduce the contact between raw product (especially the residues) and water.
  - ✚ increase the yield and thus reduce the quantity of raw product that ends up in the effluents as TSS and TDS.
  - ✚ optimise the use of food additives and cleaning/disinfecting products.”
- (Tchoukanova *et al.*, 2007:11.)

This section will explore the BMPs as illustrated in the guide. This work is an excellent guide to use as baseline for developing a framework of BMPs to attain ZED in the South African industries.

#### 3.3.5.1 Set Up a Team

The first step in the guide is to establish a work team to develop and implement the BMPs. It should be obvious that the composition of the team will exert a big influence on the success of implementing the BMPs. Therefore, it is very important that adequate resources have been allocated to the project and that all those involved (workers, technical and professional employees and leaders) adopt an attitude of cooperation and an open mind in order to facilitate the implementation of the BMP. The team should include:

- ✚ “an administrator, who will promote and facilitate, on behalf of plant management, the acceptance of the measures for the implementation of the BMP policy planned by the work team.
- ✚ an internal (production and/or maintenance manager) or external professional, who will coordinate the execution of the actions planned by the work team based upon the decisions taken, and who will ensure follow-up based on the results and the evaluations obtained.
- ✚ assistants, who will carry out the actions planned by the work team, in order to establish the BMP policy and to ensure that it is put into practice by the plant workers.” (Tchoukanova *et al.*, 2007:12.)
- ✚ environmental specialists and team members familiar with the required legislation.

#### **3.3.5.2 Draw up a Plan of Action**

“The team is responsible for the development of an action plan in order to implement a BMP policy adapted to its plant. This action plan will have to take the characteristics of each production process into account. The team will establish the objectives, define the steps of the task and fix the time limits for its implementation.” (Tchoukanova *et al.*, 2007:12.)

#### **3.3.5.3 Develop Detail Production Diagrams**

It is easier to identify and prioritise the processes and production units where the sources of pollution are and implementation of BMPs are required when the process flow with information on the water mass balance and concentrations of products used and generated for each production process are available. The same have a bearing on dissolved and suspended matter within the product streams. “A good knowledge of all the characteristics of each production process used in a plant is absolutely essential to any effective planning and implementation of BMP for raw product, water and effluents. A substantial amount of information can be summarised and presented in the form of detailed production diagrams.” (Tchoukanova *et al.*, 2007:12.)

#### **3.3.5.4 Develop Input/Output Quantity Inventories**

To develop the BMP frameworks for specific production processes, the guide for the marine products processing industry used tables to compile data in order to allow the formation of input/output inventories for a given period of production. “A period of one hour of

production has been used in the following tables, as an example, for the purposes of presenting the approach.” (Tchoukanova *et al.*, 2007:12.)

These tables will be included in this section and there will be reference made to the applicable tables in the next chapter when the BMPs for ZED in the South African industry are ascertained. “These data (Tables 2, 3 and 4) will enable you:

- ✚ to calculate the volume of potable water used, the volume of effluents, as well as the quantities of pollutants generated by the processing of one kilogram of raw product (kg TSS/kg r.p., kg TKN/kg r.p., etc.) or by the production of one kilogram of finished product (kg TSS/kg f.p., kg TKN/kg f.p., etc).
- ✚ to identify the steps of the process that generate an excessive quantity of effluents and organic pollutants (TSS, TKN, etc.).
- ✚ to identify the critical points in the process in terms of organic pollution produced, that depend on the critical management points (CMP).” (Tchoukanova *et al.*, 2007:15.)

#### 3.3.5.4.1 Determine the Quantity of Water and Products Used (Inputs)

The guide for the marine products processing industry used Table 3.3 to enter all the steps of the production process, including a list of the products used in each one of the steps.

**Table 3.3: Inventory of Products Used During One Hour by the Production Process.**

Processing steps	Products used (inputs)						
	Raw product (kg/hr)	Potable water			Chemical products (kg/hr)		
		Use	VPW (L/hr)	% of total	Salt	Phosphates	Others (nitrogen compound, etc)
1 <sup>st</sup> step							
2 <sup>nd</sup> step							
- / /-							
N <sup>th</sup> step							
Total/hour			TVPW				
Cleaning							

(Tchoukanova *et al.*, 2007:13)

“Start by determining the quantity of raw product processed. Measure the volume of potable water (VPW) used for each step of the production process (VPW<sub>step 1</sub> ... VPW<sub>step N</sub>) (in litres/hour) and identify their use (transport of the raw product or the residues,

cooking, cooling, etc.). Calculate the total volume of potable water (TVPW) used for the entire process. Calculate the percentage of flow attributable to each water stream, relative to the total flow. Measure also the volume of potable water necessary for the cleanup and enter it in the table.” (Tchoukanova *et al.*, 2007:13.)

### 3.3.5.4.2 Determine the Quantity of Products and Residues Generated (Outputs)

The guide for the marine products processing industry used Table 3.4 to enter the same steps of the production process as per Table 3.3, but this time to determine the quantity of each type of finished product and byproduct generated, as well as solid and semisolid residues generated by each of the steps.

“Note the type and physical state of each residue as soon as it is separated from the raw product, if it is in contact or not with water, and the relative duration (short or prolonged) of this contact. It is important to underscore that one of the main objectives to attain here is to isolate the residues before their contact with water, in order to limit their disintegration and their dissolution in the effluent. The choice of isolation and handling techniques mainly depends on the physical state and quantity of residues.”

**Table 3.4: Inventory of the Products Generated During One Hour by the Production Process.**

Processing steps	Generated products (outputs)							
	Finished product (kg/hr)	By-products (kg/hr)	Residues				Effluents (VEf)	
			Type and physical state	Contact with water	(kg/hr)	% of total	(L/hr)	% of total
1 <sup>st</sup> step								
2 <sup>nd</sup> step								
- / /-								
N <sup>th</sup> step								
Total/hour								
Cleaning								
Main effluent							TVEf	

(Tchoukanova *et al.*, 2007:14)

“Measure the volume of effluents (VEf) generated at each step of the production process ( $VEf_{step 1} \dots VEf_{step N}$ ) and the total volume of effluents (TVEf) generated for the whole process. Calculate the percentage of flow attributable to each water stream, relative to the total flow.” (Tchoukanova *et al.*, 2007:14.)

### 3.3.5.4.3 Determine the Physicochemical Characteristics of the Effluents Generated

The guide for marine products production process uses Table 3.5 to bring together the analyses to obtain the major physicochemical characteristics of an effluent deemed essential in order to determine the composition of the various effluents generated.

**Table 3.5: Initial Compilation of the Physicochemical Characteristics of Various Effluents**

Processing step	VEf	TSS		COD <sub>total</sub>		COD <sub>soluble</sub>		TKN		P		FOG	
	L/hr	mg/L	kg/hr	mg/L	kg/hr	mg/L	kg/hr	mg/L	kg/hr	mg/L	kg/hr	mg/L	kg/hr
1 <sup>st</sup> step													
2 <sup>nd</sup> step													
- / / -													
N <sup>th</sup> step													
Total/hour													
Cleaning													
Main effluent													

(Tchoukanova *et al.*, 2007:15)

### 3.3.5.5 Identify Critical Management Points (CMP)

The guide for marine products production process uses Table 3.6 to gather, analyse and classify the critical points of organic pollution that have been identified. Table 3.6 presents a relative scale to classify the seriousness of the identified point of pollution. “Not all factors considered may fit the definition described for a specific level of concern. If one or more of the factors considered fits best in the next higher level, the general priority of the problem should be advanced to the next higher level in the interests of adopting a precautionary approach.” (Tchoukanova *et al.*, 2007:15.)

The guide uses the example of the following problems being identified and these will also be discussed in more detail:

- ✚ BMPs for the quality of the raw product;
- ✚ BMPs for the potable water and effluents;
- ✚ BMPs for residues; and
- ✚ BMPs for chemical products.

The relative scale is used to develop the action plan:

“1. **Negligible problem** (the quality of the raw product is good, volumes of water and effluents are low, the quantities of solid residues as well as of Total Suspended Solids (TSS) and Total Dissolved Solids (TDS) are low, and the use of chemical products is absent or low)

2. **Moderate problem** (the quality of the raw product is average, volumes of water and effluents are average, the quantities of solid residues as well as of Total Suspended Solids (TSS) and Total Dissolved Solids (TDS) are average, and the use of chemical products is moderate)

3. **Significant problem** (critical management point - CMP) (the quality of the raw product is less than satisfactory, volumes of water and effluents are high, the quantities of solid residues as well as of Total Suspended Solids (TSS) and Total Dissolved Solids (TDS) are high, and the use of chemical products is excessive).” (Tchoukanova *et al.*, 2007:16.)

**Table 3.6: Organic Pollution Critical Points Compilation and Analysis**

Processing steps	Problem identification	Significance of problem	Probable sources or causes	Preventive measures to apply	Priority of execution
1 <sup>st</sup> step					
2 <sup>nd</sup> step					
- / / -					
N <sup>th</sup> step					
Cleaning					

(Tchoukanova *et al.*, 2007:16)

The approach followed by the marine products processing guide as described in the following sections will make it possible to identify the problems (critical points) and to determine the level of seriousness of each one. The researcher decided to include this approach for developing BMPs to attain ZED in South African industries.

#### **3.3.5.5.1 BMP for the Quality of the Raw Product - Storage and Handling**

The critical point identified by the marine processing industry in the quality of the raw product is associated with the storage conditions and handling of materials. A number of management measures to ensure a constant quality of the product is discussed in the marine guide, but will not be elaborated on here. Various other sources of literature include detail criteria and practices for the storage of raw materials, by-products, products and also materials used during construction. The key is to plan your storage in such a way as to prevent contact with storm water or any other effluent and to install drains that lead to treatment facilities. Special requirements should be adhered to in the storage of hazardous materials.

#### **3.3.5.5.2 BMP for the Potable Water and Effluents**

This is the key problem area as the unplanned release of effluent eventually prevents ZED conditions. The marine products processing guide also classifies the excessive use of water, and consequently the generation of large volumes of effluents linked to each step of the production process as an important critical point.

The marine guide uses Table 3.3 to classify the water streams and Table 3.4 to indicate the effluents generated at each step as a function of their volume (small volume, medium volume or high volume).

“Based on the results of your inputs/outputs budget and on the classification grid thus created, you can:

- ✚ identify problematic areas in terms of water consumption and generation of effluents;
- ✚ complete columns 2 and 3 of Table 3.6; and
- ✚ establish the distribution and relative importance of the streams of potable water and effluents on your production diagram.”( Tchoukanova *et al.*, 2007:18.)

#### **3.3.5.5.3 BMP for Residues Management**

The marine products processing guide uses the results from Table 3.3 and Table 3.4 to establish a grid of the residues generated as input into the residues portion of Table 3.4 (in terms of small, average or high quantities of residues) and a grid classification of the raw product that is found in the effluent in Table 3.5 (in terms of small, average or high quantity of organic matter). This is based upon the TSS and determines the degree of

contamination due to organic matter in the effluent. The marine products processing guide identifies the following critical points related to residues management:

- ✚ “the quantity of residues generated;
- ✚ the physical state of the residues generated (solid, semisolid, liquid);
- ✚ the quality (freshness) of the residues generated and their storage conditions;
- ✚ the duration of contact between the residues and water; and
- ✚ the intensity of contact between the residues and water” (Tchoukanova *et al.*, 2007:18.)

The advantage of using the tables presented by Tchoukanova is to:

- ✚ “identify processing steps that are more problematic in terms of residue management.
- ✚ complete columns 2 and 3 of Table 3.6.
- ✚ enter the distribution as well as importance and relative loads of organic matter for the streams of residues on your production diagram.” (Tchoukanova *et al.*, 2007:19.)

#### **3.3.5.5.4 BMP for Chemical Products**

Due to the cleaning, disinfecting, preserving and other requirements, the marine processing industry is using a range of chemical products that can be harmful to the environment. The synergy with other industries is that the use of these chemicals is unavoidable. “Based on the information gathered in Table 3.3, you can pinpoint the critical points associated with the excessive use of chemical products. This information can be transcribed and described in more detail in Table 3.6. It is also helpful to make use of the production diagram by noting on it the relative use of the various chemical products at the time of the various steps in the production process.” (Tchoukanova *et al.*, 2007:19.)

#### **3.3.5.6 Establish Verification Measures**

It is of no use implementing BMPs without verification to confirm that the BMP is successful in achieving the environmental requirements. The marine products processing guide uses Table 3.7 to register the initial and final data and to verify the BMPs on a continuous basis. This data could be used to evaluate not only the environmental but also the performance of your plant.

**Table 3.7: Compilation of Continuous Measures of Verification of the Performance of the BMP**

Used / generated products	Initial measures (before BMP)	Final measures (after BMP)	% of reduction/increase	Verification measures 1 (date)	Verification measures 2 (date)	Verification measures 3 (date)
Quantity of raw product (kg/hr)						
Potable water volume (L/hr)						
Quantity of finished product (kg/hr)						
Quantity of by-products (kg/hr)						
Quantity of residues (kg/hr)						
Volume of effluents (L/hr)						
TSS (mg/L)						
TKN (mg/L)						
FOG (mg/L)						
P (mg/L)						
BOD (mg/L)						
COD (mg/L)						

(Tchoukanova *et al.*, 2007:33)

“By comparing initial and final results, you should notice:

✚ a reduction in total volume of potable water (TVPW) used, in % =  $[(TVPW_{Initial} -$

$TVPW_{Final} / TVPW_{Initial}] \times 100.$

- ✚ a reduction in total volume of effluent (TVEf), in % =  $[(TVEf_{Initial} - TVEf_{Final}) / TVEf_{Initial}] \times 100.$
- ✚ an increase in the quantity (Qty) of finished products, in % =  $[(Qty_{Final} - Qty_{Initial}) / Qty_{Initial}] \times 100.$
- ✚ an increase in the quantity (Qty) of residues/by-products, in % =  $[(Qty_{Final} - Qty_{Initial}) / Qty_{Initial}] \times 100.$
- ✚ a reduction of the quantity (Qty) of organic matter in effluent, in % =  $[(Qty_{Initial} - Qty_{Final}) / Qty_{Initial}] \times 100.$

(where Qty can be the value in TSS, TKN, FOG, P, BOD, COD, etc.).” (Tchoukanova *et al.*, 2007:33.)

### 3.3.5.7 Establish Education Programmes

Research concluded that the education of employees is one of the key factors for success when implementing BMPs. The marine products processing guide also identifies that one of the last responsibilities of the work team is to establish an education programme to ensure receptivity to and continuity of the application of the BMPs.

### 3.3.6 Conclusion

The marine products processing guide focused on BMPs of raw product, water and effluents and contains basic information necessary so that a processing plant, regardless of its size, can undertake a programme to reduce the organic pollution generated by its marine products processing activities. Similar to numerous case studies on the environmental requirements of production processes, the guide identifies the economic and social advantages that industry will be able to realise:

- ✚ “reduction of the water supply cost (reduce volume of water).
- ✚ improvement in yield (optimal use of raw product) and quality of the finished products.
- ✚ increased opportunity to develop valuable by-products and residues.
- ✚ reduction in the cost of treatment of the effluent.
- ✚ better control of the sources of pollution.
- ✚ improvement of the corporate image, positive recognition by the community and concerned governmental authorities.
- ✚ increased pride of employees working for a processing plant concerned about the consequences of its processing activities on the environment.” (Tchoukanova *et al.*, 2007:19.)

The measures presented can be applied to all types of industrial processes. The inputs/outputs budget developed constitutes an important source of information that will allow industry to increase the performance of the plant. The strategic information derived from your own processing plant, for example, identifying sources of waste or operations whose functioning can be optimised, will be required if modifications to your industrial processes are required for ZED compliance.

### **3.4 Conclusion**

Case studies are a valuable method to research the BMPs with its distinctive characteristics. The BMPs implemented and described in these two case studies form the nucleus to develop a BMP framework to attain ZED in the South African industry in Chapter Four. The case study on effluent management for a metal finishing industry aiming at zero discharge conditions also have synergies with the Mittal Steel case study in Chapter Five that is measured against the framework developed in Chapter Four.

## CHAPTER 4 BMP FRAMEWORK TO ATTAIN ZED IN SOUTH AFRICAN INDUSTRIES

### 4.1 Introduction

The development of the BMPs should consider the operational, environmental, social, and economic constraints inherent in the South African industry to bring new and existing facilities into compliance with regulatory requirements.

The objective of the framework is to derive practices from literature and the case studies and to provide information and examples of procedures used by industry to keep pollutants from the effluent entering the neighbouring aquatic environment and to remain compliant with regulatory requirements. The BMPs are, however, not intended to replace or supersede any local, provincial or national laws, regulations, permits or ordinances that may regulate the discharge of effluent. To ensure compliance, relevant information should be obtained from these regulatory agencies. Industry will have to determine which of these practices apply to their unique facility, and implement the framework accordingly.

The BMPs in this chapter are documented to represent industries' responsibility under the following categories:

- ✚ Governance BMPs,
- ✚ Project Management BMPs, and
- ✚ Water Use Efficiency, Preventative and Operational BMPs.

Although the BMP framework embodies practices for one integrated strategy, the three categories were selected to differentiate between BMPs for management (Governance BMPs), for the project management team responsible for ZED projects (Project Management BMPs) and for the production and water departments' personnel (Water Use Efficiency, Preventative and Operational BMPs).

Each of the three categories is divided into subcategories with a number of BMPs for each of the subcategories. The intent of the BMPs under each subcategory is stated for easier reference of the BMPs. The BMPs also have a unique number (from 1 to 187) with the numbering continuing all the way through the three main categories. The flow chart below gives an overview of the structure and content of the BMPs framework.

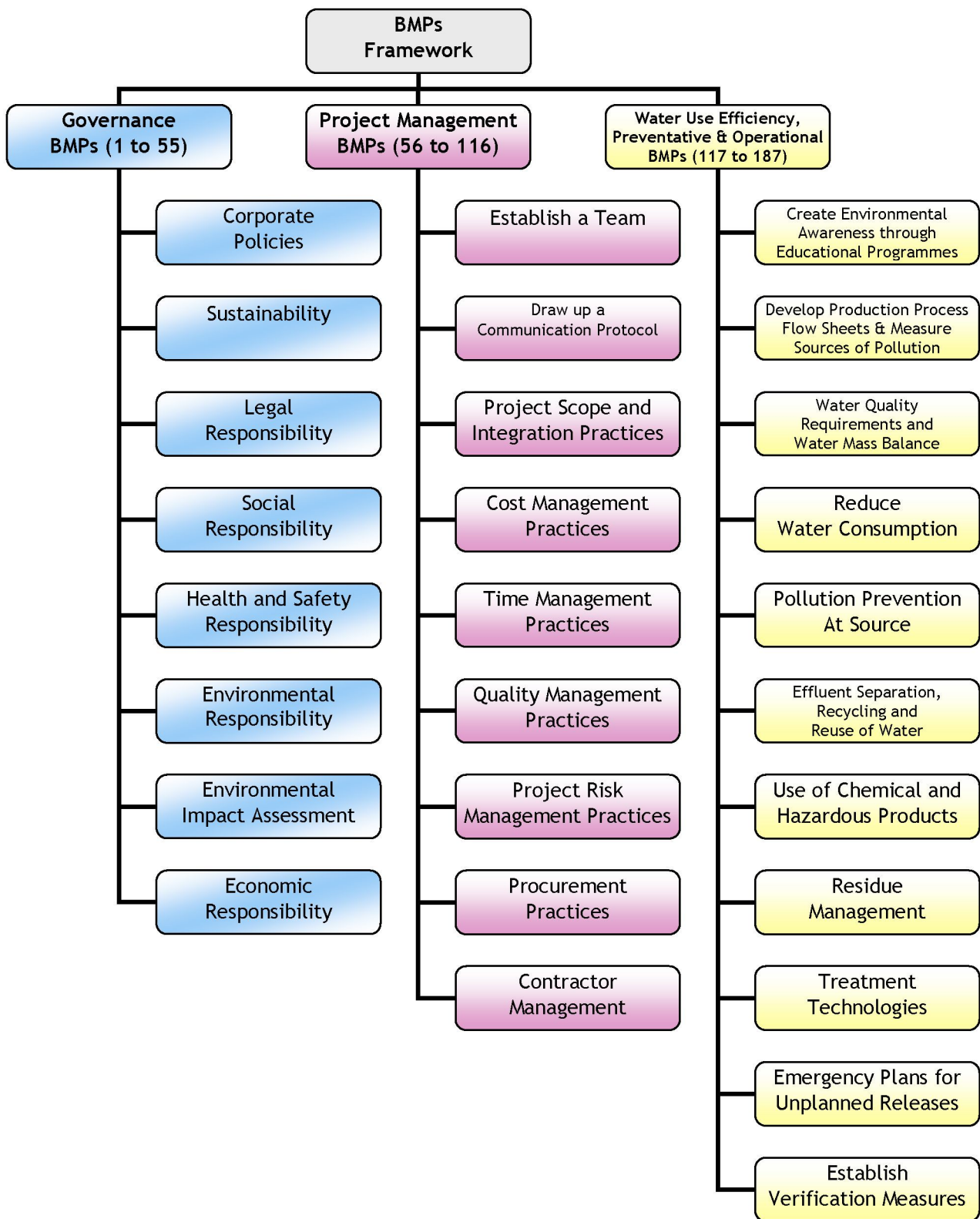

Figure 4.1: Structure of BMPs Framework

## 4.2 Governance BMPs

### 4.2.1 Corporate Policies

**Intent:**

Companies should have policies in place to govern their business and to optimise the value of their processes by applying sound commercial judgement whilst endeavouring to realise maintained long-term business sustainability in a manner that respects the environment and the health of all stakeholders.

1. The company should advocate a policy that is a forward-thinking dynamic directive focussing on key business drivers, the company's strengths and opportunities, and the strategies it intends to pursue to benefit from these strengths and opportunities to reach its business objectives. It should also focus on the weaknesses and threats to its business, and plan mitigation strategies.
2. Internal company governance structures and roles should be in place and reviewed and improved where necessary to reflect best practices. This should happen at the different management levels.
3. Ensure there is an established environmental policy based on the minimum requirements of the ISO 1400 environmental management system for the protection and sustainable development of the environment. The policy should state that the company will not compromise on safety, health and environmental values to increase profits. If ZED is a legal requirement the policy should state the company's compliance to this requirement.
4. Create a corporate culture where environmental protection and pollution control measures become part and parcel of operational planning in line with company policy.

### 4.2.2 Sustainability

**Intent:**

South Africa has signed and ratified certain important international conventions that aim to protect the environment. One of the most important of these is the Convention on Biodiversity. The main purpose of this convention is to encourage governments to apply the principles of sustainable development in the running of their countries and the management of natural resources. The intent of these BMPs is to have systems (political, economic, social, production, etc.) in place to protect and improve the community's resources so that environmental processes, on which life depends, are maintained and quality of life can be improved.

5. Identify the critical success factors to compete in the specific industry. Compare the industry's critical success factors with alternative business proposals to determine the facility's:
  - ✚ strengths,
  - ✚ weaknesses,
  - ✚ opportunities, and
  - ✚ threats.
6. Assess the competitiveness of each business alternative with that of the other industry players by doing a value chain analysis and cash cost analysis.
7. The social, economic and environmental impacts of activities, including disadvantages and benefits, should be considered, assessed, and evaluated, and decisions should be appropriate in the light of such consideration and assessment.
8. Management should endorse the application of sustainable development practices by its employees. The international importance of sustainable development was officially recognised by the world community at the first Earth Summit in Rio de Janeiro, Brazil, in 1992. The second Earth Summit took place in Gauteng in 2002. It was called the World Summit on Sustainable Development (WSSD) in recognition of the need for balance between environmental and human development. The second World Water Development Report assists in the monitoring of progress towards achieving the targets set at these summits. Subsequent editions of the report are scheduled for 2009, 2012 and 2015 and the understanding of the interrelated water issues by the relevant employees will enhance the ability to manage water and the related challenges and apply the principles of sustainable development properly.
9. It is good practice to publish a sustainable development report in accordance with the Sustainability Reporting Guidelines of the Global Reporting Initiative (GRI) to review the company's economic, social and environmental performance for a given financial year. The sustainable development report should be integral to the company's drive towards facilitating positive transformation in its company, as well as in South African society and its economy.

#### 4.2.3 Legal Responsibility

**Intent:**

There are substantial and complicated legal requirements involved in any business and the impact of legislation is affecting the sustainability of industry, especially when ZED compliance is a requirement.

10. The legal system is a specialist area and legal advisers should be appointed to be responsible for creating a proper legal framework for your company.

11. A checklist should be compiled with the relevant Acts and Regulations to guide the project team through the maze of intricacies normally encountered when dealing with legislation. The identification of the different courses of conduct that can be followed and the choice of the most acceptable alternative will have an influence on the validity in selecting a specific BMP. International conventions, treaties and declarations, as well as National, Provincial and Municipal legislation should be included in the framework.
12. Investigate if there are patent systems related to new technologies and obtain the required knowledge about the legislation and regulations and also if there is a patent register that could be searched.
13. The following Acts and Regulations should be considered when dealing with BMPs to attain ZED status in South Africa:
  - ✚ South African Constitution (*Act 108 of 1996*) (where Section 24 deals with the health and well-being of all involved and Section 32 with access to information).
  - ✚ *National Environment Management Act (108 of 1998)*.
  - ✚ *National Water Act (36 of 1998)* (controls the pollution of water by any waste, which includes solid material that is suspended, dissolved or transported in water (including sediment) and which is spilled or deposited on land or into a water resource in such volume, composition or manner as to cause, or to be reasonably likely to cause, the water resource to be polluted).
  - ✚ *Environment Conservation Act (73 of 1989)* (for the control of pollution from littering, waste disposal, noise, etc).
  - ✚ *Occupational Health and Safety Act (Act 85 of 1993)*, and Regulations: Particularly the *Hazardous Biological Regulations* (worker health and safety, and training).
  - ✚ *Health Act (63 of 1977)* (for the control of the health aspects of waste disposal and water treatment) and the proposed Regulations for the control of environmental conditions constituting a danger to health or a nuisance.
  - ✚ National Environment Management: *Air Quality Act No. 39: 2004*.
  - ✚ *Hazardous Substances Act (15 of 1973)*.
  - ✚ *Atmospheric Pollution Prevention Act (45 of 1965)* (for the control of air pollution from waste (e.g. incineration facilities, landfill sites).
  - ✚ *Nuclear Energy Act (Act 92 of 1982)* (radioactive waste).
  - ✚ National Building Regulations (storage requirements).
  - ✚ *National Road Traffic Act (93 of 1996)*, and Regulations and an EIA requirement, also incorporating the following SANS Codes:
    - 10228: Identification and Classification of Dangerous Substances,
    - 10229: Packaging of Dangerous Substances for Road and Rail Transportation,
    - 10230: Transportation of Dangerous Substances: Inspection Requirements for road vehicles,

- 10231: Transportation of Dangerous Substances: Operational Requirements for road vehicles,
  - 10232-1: Transportation of Dangerous Substances: Emergency information System for Road Transportation, and
  - 10233-3: Transportation of Dangerous Substances: Emergency information System: Emergency action codes.
- ✚ This is by far not a complete list but should serve as a reminder. There are also a number of draft papers and policies which might be relevant but not mentioned here.

#### 4.2.4 Social Responsibility

**Intent:**

The company's social responsibility objective should include the amalgamation of improvement of the corporate image, positive recognition by the community, concerned governmental authorities and other interested and affected parties and the increased pride of employees working for a company concerned about the consequences of its processing activities on the environment.

14. The social responsibility dimension of the triple bottom line represents a change from the historic practices which have concentrated on the technical issues of the industry. Practices of social responsibility should be incorporated in the management, design and implementation of projects.
15. Stakeholder engagement is important as part of the social responsibility and the best strategy is to interact actively with stakeholders rather than passively interact and respond. Involving communities in the decision making process will build trust and acceptance between the industry and the neighbouring communities.
16. Industry should take cognisance of the property rights of the neighbouring community with regards to effluent discharge as well as seepage into underground systems. Potential impacts on neighbouring communities should be considered in the operating of production processes.
17. The impact of socially related issues by neighbouring communities such as resettlement, compensation claims, loss of livestock, noise pollution, water pollution, aesthetic complaints and development issues should be considered in decision making.
18. ZED constitutes that no polluted water will be released to the neighbouring communities. Investigate the possibilities of implementing measures to supply smaller communities and households with safe drinking water as part of the holistic water management plan.

19. Ensure that there is a commitment so that the company could be managed in an ethical way that strikes an appropriate and well reasoned balance between economic, social and environmental needs and is committed to:
- ✚ conducting business with respect and care for people and the environment.
  - ✚ continually improving safety, health and environmental performance.
  - ✚ complying as a minimum with all applicable legal and other agreed requirements.
  - ✚ responsible utilisation of natural resources.
  - ✚ promoting dialogue with stakeholders about safety, health and environmental performance.

#### 4.2.5 Health and Safety Responsibility

**Intent:**

Domestic and personal hygiene go hand in hand with access to safe drinking water and sanitation. Water related diseases should be prevented by setting, validating, monitoring and pursuing the proper implementation of norms and standards and applying an integrated approach to human health and water resource management

20. Create a guideline with the essential elements of the company's Safety, Health and Environmental (SH&E) Risk Management Process as a generic approach to the profiling and management of SH&E risks. It should serve as a high level framework referring to the various types of SH&E Risk Assessments performed in the company when addressing ZED requirements.
21. It is important to have knowledge of the MDGs and to have knowledgeable resources available and indicators in place to assess the status and monitor the progress of your company towards meeting the targets with respect to water related health issues. Refer to Appendix B for a summary of the role water plays in achieving the goals and the positive impact ZED compliance will have on the environment.
22. There are three key international guidelines on water quality relevant to human health and these guidelines should be used to set the targets and standards of the company's water management plan. Although these guidelines are addressed to policy makers and health regulators to assist in setting national standards, it should give the necessary guidance with regard to permissible effluent discharge levels. The Guidelines for Drinking Water Quality, Guidelines for the Safe use of Wastewater, Excreta and Greywater and Guidelines for Safe Recreational Water Environments and many others are available on-line at [www.who.int/water\\_sanitation\\_health/norms/](http://www.who.int/water_sanitation_health/norms/).
23. It is important to do a health impact assessment and incorporate the human health considerations into the overall and integrated water management plan.
24. Include all stakeholders and make provision to include all the various uses and users

of water in the planning, development and management of water resources. Mitigating health risks requires holistic approaches and should involve all stakeholders to enhance knowledge sharing, set realistic measures for the improvement of health and encourage the protection of the aquatic environment to improve water quality for the safe use by communities.

25. Ensure that there are risk management strategies in place, taking cognisance of the chemicals and their concentrations present in the water and its implications on health.
26. Establish a management system framework for the implementation of a uniform Process Safety Management System, based on the United States Department of Labour's Occupational Safety and Health Administration (OSHA) process safety requirements. South African legal requirements to process safety requirements also have to be followed. This framework should form an integral part of the application of management and engineering principles to prevent fires, explosions and accidental chemical releases, as well as fatalities and injuries at industrial process facilities.

#### 4.2.6 Environmental Responsibility

**Intent:**

The South African Constitution (1996) says that each and everyone has the right to a safe and healthy environment. The quality of our environment affects all of us and therefore everyone has a responsibility to protect and use the environment in a way that will protect it for us, our children, and our grandchildren. South African industries should show their environmental responsibility to maintain the highest standards in terms of biodiversity protection, hygiene, safety, air and water quality and overall environmental performance.

27. Environmental legislation is undergoing significant reform in South Africa and the focus of every industrial activity should be to support the overall national objective of sustainable development.
28. It is important to understand the contents of and to apply practices complying with The Bill of Rights, as contained in Chapter 2 of the Constitution of the Republic of South Africa Act 108 of 1996. These regulations deal with protection of environmental rights as contained in section 24 under the heading "Environment". The enforcement of the environmental rights in section 24 in the Bill of Rights is facilitated by several subsidiary measures, policies and numerous acts.
29. It is important to know your industry's environmental requirements and to ensure the necessary systems are in place to obtain and sustain compliance. NEMA provides a framework for the country in its approach to the environment. It covers the following areas:

- ✚ land, planning and development,
  - ✚ natural and cultural resources, use and conservation, and
  - ✚ pollution control and waste management.
30. A number of government departments have specific responsibilities to address different aspects to sustain our environment and safety. Interaction and open communication with these departments should be encouraged. For example, the labour department has inspectors who visit places of work to see that workers do not work in unsafe conditions. The health department and municipalities take responsibility for hygiene, waste management, etc. The Department of Agriculture, Conservation and Environmental Affairs as well as the Department of Water Affairs and the Department of Tourism deal with pollution of rivers.
  31. One of the major components of environmental management is the identification of the different courses of conduct that can be followed and the choice of the most acceptable alternative. This will have an influence on validity in selecting a specific BMP. It is only possible to make a valid and reliable choice if the alternative courses of conduct are quantified and can be compared effectively.
  32. Provide input with regard to the environmental aspect into the Safety, Health and Environmental (SH&E) Risk Management Process Guideline discussed under the Health and Safety Practices.
  33. Development must meet with the requirements of sustainability. In essence it requires that all present or planned developments should be analysed to determine whether they cause or might cause external costs.
  34. The company's environmental management plan and strategies to attain or sustain ZED should be a transparent plan according to a clearly stated policy on a company/facility wide level. Environment management objectives should be expanded to develop plant/facility level objectives in terms of water usage and effluent discharge.
  35. Interim goals and plant/facility targets should be implemented in terms of water utilisation and effluent discharges to manage non-compliance with the overall objective.

#### 4.2.7 Environmental Impact Assessment

**Intent:**

EIA Regulations were promulgated in terms of Section 24(5) of NEMA on 21 April 2006 in Government Notice R 385. The regulations define the requirements in terms of Chapter 5 of NEMA for the submission, processing, consideration and decision of applications for environmental authorisation of listed activities. Two lists, defining activities that require either basic assessment or scoping in terms of Sections 24 and 24D of NEMA were published

in Government Notice R 386 and R 387 respectively. Any activity that is captured under either of these lists requires environmental authorisation from the pertinent authority.

36. It is important to start with compiling a SH&E assessment package where the key SH&E considerations of strategic significance are considered. These include legal implications (e.g. ZED compliance, emerging issues, public perception), environmental concerns (e.g. significant pollutants, siting), process matters (e.g. major hazards) safety and health (e.g. people aspects) and product issues (e.g. regulated substances).
37. It is also important to identify the relevant role-players to be involved in the EIA process and to appoint an EIA Specialist to manage the process.
38. The EIA should aim to achieve the following:
  - ✚ supplementing, where necessary, assessments of social and biophysical environments affected by the proposed projects.
  - ✚ assessing impacts on the study area in terms of environmental criteria.
  - ✚ identifying and recommend appropriate mitigation measures for potentially significant environmental impacts.
  - ✚ undertaking a fully inclusive public participation process to ensure that I&AP issues and concerns are recorded and addressed.
39. Refer to the simplified process flow of the EIA process in Chapter 2 and compile a specific process flow with key dates as required for the specific project.
40. The characteristics of each potential environmental impact should be identified. Use Table 2.1 included in Chapter Two.
41. The EIA Specialist determines, with assistance from the dedicated team members if an EIA is legally required in terms of Section 24(1) and 24(F) of the National Environmental Management Act, Act no 107 of 1998, specifically according to the listed activities in GNR 386 & 387. Where relevant a pre-application consultation with the pertinent authority to determine the EIA route is required. There are four potential EIA routes that may be applicable to projects:
  - ✚ no EIA legally required.
  - ✚ basic Assessment.
  - ✚ full EIA.
  - ✚ exemption can be applied for certain parts of basic or full assessment.
42. If the activities associated with a specific project are not listed in GNR 386 or 387, no EIA will be required. In such cases it is good practice to schedule a meeting with the project team to confirm that the specific activities associated with the project are indeed not listed in GNR 386 or 387.
43. When applying for exemption from any of the EIA requirements in terms of Chapter 5 of the EIA regulations under Section 24(1) and 24(F) of the *National Environmental Management Act, Act no 107 of 1998*, then the EIA specialist in the team should:

- ✚ submit an exemption application to the relevant authority together with the required motivational documentation.
  - ✚ initiate the application process to obtain other necessary environmental permits and certificates, if any.
  - ✚ obtain a written Exemption Notice on the exemption application from the relevant authority.
  - ✚ initiate actions, if any, required to comply with conditions of the Exemption Notice.
  - ✚ ensure that the public participation requirements, if any, for the exemption authorisation are adhered to.
  - ✚ submit the Exemption Notice to the relevant authority together with the EIA application documentation.
44. If the project must follow the Basic Assessment or Full EIA route, the EIA Specialist
- ✚ appoints a suitable independent Environmental Assessment Practitioner (EAP) through the approved commercial process and makes project information available to the EAP.
  - ✚ finalises, together with the EAP, the extent of the project.
  - ✚ ensures that a notice of intent to submit an application for Basic Assessment is compiled and submitted by the EAP. He has to ensure that the EAP obtains an acceptance letter on the application form from the relevant authority.
  - ✚ ensures that the public participation process is conducted by the EAP, in line with the requirements under Section 56 of GNR 385. Refer to section 2.2.3.5 for guidelines during the public participation process.
  - ✚ ensures that the EAP submits the application form, basic assessment report and relevant public participation documentation to the relevant authority.
  - ✚ ensures that the EAP obtains an environmental authorisation on the relevant report from the relevant authority. Reports will vary depending on the EIA route followed and can be one of the EIA Basic Assessment Report, EIA Scoping Report, Plan of Study for the EIA or the EIA Report.
  - ✚ updates the Aspect Register with the information gathered during the EIA Phase (including internal and external specialist reports and environmental authorisation conditions).
  - ✚ ensures that EIA information and requirements are fed back to the project team and incorporated into the design where required. Where relevant, he ensures that the EIA deliverables are monitored.
45. The Project Environmental Assessment Records should be available at all times for ad hoc or formal in-house auditing by the project team or by any of the interested and affected parties.
46. The EIA Specialist should ensure the necessary implementation, verification and close-out of all the EIA activities were done as per the requirements.

#### 4.2.8 Economic Responsibility

**Intent:**

The economic dimension, or in other words, the value of water, is one of the most important, but also one of the more difficult principles of water use and ultimately water use efficiency to quantify. The advantages and also the limitations of the different techniques used in the economic evaluation of water are important to all stakeholders. These issues play a role in the decisions taken by policy makers, in the strategies chosen by industrial management, in the decisions by engineers responsible for designing plants and also for the public in expressing their personal tastes and preferences. Water governance must be a shared responsibility and everyone should be able to use the available tools.

47. Chapter 12 of the WWDR 2 Report discusses different mechanisms for the valuation and charging of water and also confirms the difficulty in attempting to value water. To make use of these mechanisms, informed decision relies upon such information developed largely through regular monitoring and data collection. Indicators which focus on critical aspects of water resources management and allocation have an important role to play in developing efficient and effective systems of water governance.
48. More water will be available for use by others if everyone contributes to the efficient use of the water in the relevant system. Refer to the indicators discussed in Chapter 2 (2.3.6) which can be used as principles to determine the BMP for a specific industry.
49. Consideration of the economic significance of anticipating and avoiding environmental damages should always be the focus and will also become evident when one considers the costs of remediation, not to mention the social costs involved in such an exercise.
50. In South Africa there are also a number of policies which deal with the principle of water pricing and it is every company's responsibility to become familiar with the contents of these policies. The pricing strategy can be applied to achieve social equity, to fund costs of water resource management, development and use, and to achieve an equitable and efficient allocation of water.
51. Water quality management, and in particular where ZED is compulsory, can be supported by applying the 'polluter pays' principle and the importance of the application of this principle can have damaging consequences. A typical application of these principles is contained in section 56(6) of the National Water Act 36 of 1998 that states that in setting a pricing strategy for water use charges, the Minister may consider incentives and disincentives:
  - ✚ to promote the efficient and beneficial use of water,
  - ✚ to reduce detrimental impacts on water resources, and
  - ✚ to prevent the waste of water.
52. Always consider the company's official long-term economic forecasts when planning

to become a ZED compliant facility.

53. Consider requirements for capital applications, i.e. requirements for business plan, production plan, evaluation of alternative values and requirements for economic evaluations.
54. Develop an economic model to justify the viability of any planned activity. The assistance of accountants would be required for a proper model.
55. Risks should be identified qualitatively for each alternative and included in the economic model. Quantify the risks in terms of potential ranges (minimum and maximum values). Do an analysis to identify and rank the variables affecting the outcomes of the economic model. Evaluate each of the options considering the associated risks.

### 4.3 Project Management BMPs

#### 4.3.1 Establish a Team

**Intent:**

These BMPs involve the development of individuals and sub-teams into a cohesive project unit with the common purpose of meeting project objectives. The BMPs should include determining the resources required for managing tasks, both within the core project team and the broader organisational matrix related to the ZED requirements. Staff recruitment, selection, training and development should be conducted to accommodate changes throughout the project life cycle.

56. The BMPs to attain ZED in industry will be implemented by people and not by techniques and systems. It is imperative that attention is given early on to unite the individuals into a team who trust each other and work well together.
57. Resource requirements for individual tasks should be determined, in consultation with appropriate stakeholders, to establish a basis for determining staffing levels and competencies.
58. Project organisation and structure should be developed and agreed upon with higher authority to optimise alignment of project tasks of individual and group competencies with regard to ZED.
59. Staff should be recruited, allocated to, and within the project, and reallocated within the organisation, as agreed with higher authority, to meet competency requirements throughout the project life cycle. It is very important that the resources allocated to the project and all those involved (workers, technical and professional employees, leaders) adopt an attitude of cooperation and an open mind in order to facilitate the implementation of the BMPs as part of the ZED requirements.
60. The team should include:

- ✚ an administrator who will promote and facilitate the implementation of the BMPs to attain and sustain a ZED status, according to the strategy planned by the work team.
  - ✚ an internal or external professional who will coordinate the execution of the actions planned by the work team based on the decisions taken, and who will ensure follow-up based on the results and the evaluations obtained.
  - ✚ team members from all project management, engineering and related disciplines who will carry out the actions planned in order to establish the BMP strategy and to ensure that it is put into practice.
  - ✚ environmental specialists for the different fields of expertise in environmental compliance and team members familiar with the required legislation.
61. Internal and external influences in individual and team performance and morale should be analysed and action should be taken to make sure these influences do not have a negative impact on the project.
  62. Procedures for interpersonal communication, counselling and conflict resolution should be established and maintained to promote a positive working environment.
  63. Intraorganisational, interproject and intraproject conflict should be identified and positively managed to ensure all team members are dedicated in applying the BMPs to attain ZED.
  64. The project management team should identify the stakeholders, determine what their needs and expectations are, and then manage and influence those expectations to ensure a successful project. Project stakeholders are individuals and organisations who are actively involved in the project, or whose interests may be positively or negatively affected as a result of project execution or successful project completion.

#### 4.3.2 Draw up a Communication Protocol

**Intent:**

A communication protocol is drawn up to determine information and communication needs between all stakeholders and team members. Good communication management provides the required link between people, ideas and information and ensures timely and accurate generation, collection, distribution and storage of information, using formal structures and processes.

65. A communication plan should be developed to manage and direct the communication flow to all relevant stakeholders during the application of BMPs and the execution of related projects. The plan should provide the critical links between people, ideas and information which are all necessary for project success and describe how the project team will handle internal and external communication to all stakeholders and how ad

- hoc communication needs, such as queries from the press, will be dealt with.
66. If the team will depend mostly on technology mediated communication it is important to allow the team members to meet and get to know each other. They should also be encouraged to use technology in an informal manner to become acquainted with the communication tool and to become comfortable with its use.
  67. Take note of the communication constraints specific to the project being planned. Restraints may even be related to language differences and translation facilities. Alternative forms of communication from the standard may have to be considered.
  68. Determine all stakeholders that should be included in the communication plan. Stakeholder characteristics and demographics, the information required by a stakeholder and the originator, media benefits and limitations of the various options all need to be considered
  69. Determine who needs what, when they will need it and how it will be given to them. This may be identified by a stakeholder needs analysis.
  70. Various meetings should be held regularly during the project duration to ensure that proper governance prevails. These should include Steering Committee Meetings, Project Progress Meetings, Cost and Risk Review Meetings and Technical Meetings. Special meetings should be organised, if and when required, to discuss such issues as cannot be addressed at the abovementioned meetings. Minutes should be taken during these meetings to capture tasks allocated and decisions made which will have an impact on the project.
  71. There are various ways in which information could be shared within the company. Newsletters, coffee sessions, notice boards, communication forums, meetings, e-mails etc. can all be used to do so.
  72. In many cases the external information sharing regarding compliance to legal requirements such as the discharge of effluents should not take place without the approval of the corporate communication department and can only be handled in accordance with the corporate communication policy.
  73. The substantial body of source documentation employed in all the phases towards ZED should be referenced and indexed for future use. The implementation of ZED practices will no doubt require further refinement and optimisation over time. Access to the original source documentation will be essential to remain ZED compliant.

#### 4.3.3 Project Scope and Integration Practices

**Intent:**

The scope of a project comprises a combination of the end products of the project and the work required to produce them through a plan of action. Integration is the management of overall project scope in the context of schedules, budgets, risks and contracts towards

establishing agreed baselines for supplier/client requirements.

74. The team should compile an action plan in order to implement the company's BMP strategy. This action plan should take the characteristics of each production process into account. The team should establish the objectives, define the steps of the task and fix the time limits for its implementation.
75. All stakeholders should be identified to determine the influence of every possible interested party on achievement of the successful implementation of all projects related to achieving ZED.
76. Any new project's objectives, deliverables, constraints and principal work activities should be defined and recommended as the basis for agreement between the project team and management to ensure alignment with company strategy, governance and policies. Links should be established and maintained to manage the alignment between the objectives of any new project in a facility and the organisation's environmental requirements and objectives throughout the different project life cycles.
77. Scope definition, scope management strategies and plans should be developed, agreed upon and communicated to ensure clarity of understanding and ongoing management of project scope.
78. The requirements of all the functions within the project team should be analysed, rationalised and integrated, to determine agreed and achievable objectives.
79. Integrated control mechanisms should be derived to accommodate change throughout the life cycle of all ZED related projects and actions.
80. The impact of conflicting requirements of different levels of management within the organisation on individual areas or on the overall projects should be managed to achieve project as well as ZED objectives or, if necessary, to modify project objectives to remain compliant with the environmental requirements.
81. A change management system should be established and maintained for forming the basis of ongoing scope management. The impact of potential, perceived and actual scope changes should be analysed and actions should be taken to achieve or modify project and ZED objectives throughout the project life cycle. The team should establish and implement written procedures to manage changes to process chemicals, technology, equipment, and procedures; as well as changes to facilities that affect a covered process. Prior to the change, the following considerations should be addressed:
  - ✚ the technical basis for the proposed change;
  - ✚ impact of change on Safety, Health and Environment;
  - ✚ modifications to operating procedures;
  - ✚ necessary time period for the change;
  - ✚ authorisation requirements for the proposed change;

- ✚ up-dating Process Safety Information, Process Hazard Analyses and Operating Procedures;
  - ✚ relevant training dependant on the work to be performed; and
  - ✚ all relevant employees should be retrained in those operating procedures affected by the implementation of the change, prior to start-up.
82. Sessions should be conducted about the scope management lessons learned in order to provide for application in planning and implementation of other projects in a ZED environment.

#### 4.3.4 Cost Management Practices

**Intent:**

Cost management includes the processes required to identify, analyse and refine project costs to produce a budget and is used as the principal mechanism to control project cost. This should focus on the cost management for the implementation of projects and not the total economic responsibility of the organisation.

83. Develop a project budget
- ✚ Resource requirements for individual tasks should be determined in consultation with appropriate stakeholders to provide a basis for attributing expenditure.
  - ✚ Project costs should be estimated to enable budgets and cost management processes to be developed at an appropriate level throughout the project life cycle.
  - ✚ Cost strategies and cost management plans should be developed, communicated and implemented to ensure clarity of understanding and ongoing management of project finances.
84. Manage the project costs
- ✚ Cost management systems should be developed and maintained to monitor actual expenditure and to control costs throughout the project life cycle.
  - ✚ Analyses should be conducted, options should be evaluated and responses to cost variations should be implemented to maintain control over changing financial and overall project objectives throughout the project life cycle.
  - ✚ Internal and external influences on project costs should be monitored to forecast, and if necessary, seek approval from higher project authority for major changes to the approved project budget.
85. Manage the financial completion
- ✚ Finalisation of activities should be managed to achieve integrated financial and physical project completion.
  - ✚ Project outcomes should be reviewed and analysed to determine the effectiveness of the cost management systems and to improve the planning and implementation

of these practises for other projects.

#### 4.3.5 Time Management Practices

**Intent:**

Management of project time relates to the activities associated with development, analysis and control of project schedules. Meeting project objectives within the identified time frame is a critical factor when projects are implemented to ensure ZED compliance as per environmental requirements and deadlines set by governing bodies.

86. The duration and effort, sequence and dependencies of tasks should be determined from the output of scope definition and with input from appropriate stakeholders, as the basis for the project schedule.
87. Time management methods, techniques and tools should be selected, modified as required, and used to assess different options, and to determine and align preferred schedule and time management plans, resource allocation and financial requirements.
88. It is important when the final schedule is accepted, that the schedule is formalised as appropriate, and communicated to stakeholders as the basis for planning, implementation, review of progress and for subsequent schedule revision.
89. Mechanisms should be developed, implemented and modified to monitor, control, record and report actual progress in relation to the agreed schedule and plans.
90. Ongoing analyses should be conducted to identify and forecast variances and trends and to develop responses to achieve project objectives throughout the project life cycle.
91. Progress should be reviewed and the schedule should be refined throughout the project life cycle to ensure consistency with changing scope, objectives and constraints related to time and resource availability.
92. Responses to perceived, potential or actual schedule changes should be initiated and managed to achieve project objectives throughout the project life cycle.
93. When promised deadlines will definitely not be achieved, the appropriate governing bodies should be informed and the necessary steps followed to ensure the required permission for certain non-compliances such as effluent discharge conditions, is obtained.

#### 4.3.6 Quality Management Practices

**Intent:**

Quality management applies objective standards and processes to achieve the goal of

environmental compliance and stakeholder satisfaction through the continuous application of quality planning, quality control, quality assurance and continuous improvement throughout the project life cycle as well as the day-to-day activities in all the processes.

94. Quality objectives, standards, levels and criteria should be determined in consultation with stakeholders to establish the basis for quality outcomes.
95. Quality management methods, techniques and tools should be selected, modified as necessary and used to assess options and determine the preferred mix of quality, capability, cost and time.
96. Quality criteria should be identified and communicated to stakeholders to ensure clarity of understanding and achievement of quality and overall project objectives.
97. Results of project activities and product performance should be analysed to determine compliance with agreed quality standards and environmental requirements.
98. Causes of unsatisfactory results should be identified, in consultation with clients and stakeholders, and appropriate actions should be initiated to enable continuous improvement in quality outcomes.
99. Inspections of quality processes should be initiated and results should be analysed to determine compliance to quality standards with overall quality and environmental objectives.
100. A quality management system should be developed and maintained to enable effective management and communication of quality issues and outcomes.

#### 4.3.7 Project Risk Management Practices

**Intent:**

Risks are factors which might adversely affect project outcomes and ultimately environmental compliance. Risk management should address the processes concerned with identifying, analysing and responding to uncertainty. It should also include maximising the results of positive events and minimising the consequences of adverse events.

101. Potential, perceived and actual risk events should be identified, documented and analysed, in consultation with appropriate stakeholders, as the basis for risk management planning.
102. Risk management methods, techniques and tools should be selected and modified as necessary to analyse information, evaluate options and determine preferred risk approaches within the overall project environment.
103. Risk management plans and strategies should be developed, communicated to the appropriate stakeholders and managed to ensure clarity of understanding and

achievement of project objectives and environmental requirements throughout the project life cycle.

104. A risk management system should be developed and maintained to enable effective management and communication of risk events, responses and results to stakeholders. Projects should be managed in accordance with agreed project and risk management plans to ensure common approach to achievement of objectives.
105. Progress should be reviewed, variances analysed and risk responses initiated to achieve objectives with minimal disruption and conflict in a changing environment.
106. Internal and external risks to project outcomes should be monitored and remedial actions initiated to achieve project objectives, or if necessary, to modify project objectives to fulfil the environmental requirements.

#### 4.3.8 Procurement Practices

**Intent:**

Project procurement involves the management of contracting activities from formation, such as product and contract definition, market analysis, through the tendering process up to contract formation, to contract performance, management and administration after contract award. Project procurement management concludes with contractual aspects of the project finalisation processes. Subsequent BMPs for a contractor management system is included in the next section.

107. Procurement activities should be defined and planned early and refined throughout the project life cycle to ensure changing project objectives are met. Whether involvement in the procurement process is as the client, the prime contractor, or as a sub-contractor, it may influence the perspective from which the procurement activities are addressed. However, similar project management processes would normally apply.
108. Plan Project Procurement
  - ✚ Product specifications, environmental requirements and procurement strategies should be identified, analysed and prioritised, in consultation with appropriate stakeholders, as the basis for procurement planning and the contracts required to ensure ZED compliance.
  - ✚ Procurement strategies, methods and management plans should be developed, agreed upon and managed to reflect changes to project objectives throughout the project life cycle.
109. Set up and manage the Procurement Process
  - ✚ Potential sources capable of fulfilling procurement requirements should be identified and evaluated to determine the extent to which project objectives can

be met.

- ✚ Selection processes and selection criteria should be determined in consultation with stakeholders and communicated to prospective contractors to ensure fair competition.
- ✚ Higher project authority endorsements should be obtained when necessary to ensure procurement actions accord with organisation, and project and policy objectives.
- ✚ Proposals should be developed, agreed upon, and communicated to prospective contractors to ensure clarity in understanding of project objectives, responsibilities and methods of achievement.
- ✚ Responses should be evaluated and preferred contractors should be selected in accordance with agreed selection processes. The importance of the contractor's safety performance and programmes and compliance with environmental requirements should be weighed accordingly in the evaluation process.
- ✚ Contract terms and conditions should be negotiated to agree on common goals and to minimise uncertainty.

#### 110. Manage the Contracts

- ✚ Procurement activities should be managed in accordance with agreed contract and procurement management plans to ensure a common approach to achievement of objectives.
- ✚ Progress should be reviewed, variances analysed and agreed changes should be implemented to ensure project objectives are met within the legal framework of the contract.
- ✚ Potential, perceived and actual contractual conflicts should be identified and remedial actions implemented to minimise disruption to achievement of contract and project objectives.
- ✚ Reference should be made to the contractor management BMPs in the next section.

### 4.3.9 Contractor Management

**Intent:**

A contractor management system should be established to ensure the contractor complies with the environmental requirements when executing projects within the boundaries of a ZED compliant process.

111. Obtain and evaluate information regarding the contractor's safety performance and programmes and compliance with environmental requirements.

112. Contractors are to be informed of potential hazards, the facility's emergency procedures, and internal codes of practices such as safe work practices in process

- areas, ZED compliance and their responsibility to maintain an injury/illness log (including tracking of their recordable case rate).
113. Specifically inform contract employers of the known potential fire, explosion, or toxic release hazards related to the contractor's work, as well as the applicable provisions of the emergency action (response) plan.
  114. Contractors are to ensure that contractor employees are trained in safe work practices, documenting such training, and ascertaining that their employees know about potential process hazards and zero effluent release practices.
  115. Contractors should also advise the site employer of hazards posed by the contract work or hazards identified by contract employees.
  116. Evaluate the performance of contract employers in fulfilling their obligations.

#### **4.4 Water Use Efficiency, Preventative and Operational BMPs**

##### **4.4.1 Create Environmental Awareness through Educational Programmes**

**Intent:**

These BMPs should focus on enhancing the knowledge base and the development of capacities to fill the void between the historic way of managing water and the desired sustainable water governance principles. People need to be educated in the effective management of water and also on the impact industry can have on the environment.

117. The WWDR 2 illustrates the responsibility of the leaders of developing countries to create an enabling environment to enhance the existing local capacities and the knowledge base on water, by setting policies, ensuring adequate funding, and empowering local institutions and stakeholders with decision making responsibilities, and to monitor performance to ensure good governance and transparency. The support of all industries is vital to success in this regard and management should take the lead in creating environmental awareness.
118. Public education will have a direct effect on the attitudes of people on water governance and the focus of industry should be to involve all stakeholders in the awareness programmes used in industry. Refer to the sources included in Chapter 2 (Table 2.3) for information on how to perform capacity assessments.
119. Develop and implement written operating procedures, safe work practices and clear instructions for the control of hazards during operations and maintenance within the company.
120. Review the operating procedures as often as necessary to ensure that they reflect operating practices supporting ZED.
121. Appropriate training in applicable tasks and procedures should be provided to affected employees to enable them to perform their jobs safely and effectively under

- a variety of operating conditions. Environmental awareness and the regulations that should be complied with (example ZED) should form part of this training. Emphasise the importance of keeping pollutants from storm water systems.
122. Initial training for new employees should include verification that employees involved with a covered process have the required knowledge, skills and abilities to safely perform their duties and responsibilities and understand the environmental consequences of their actions.
  123. Initial training: Each operator should be trained in an overview of the process and in the operating procedures. The training should include emphasis on the specific safety and health hazards, emergency operations including shut-down, safety critical tasks and safe work practices applicable to the employee's job tasks.
  124. Hazard and Operability training: Each operator should be trained in those process scenarios that can lead to process safety incidents such as loss of containment, explosions or fires. Lessons learnt from previous studies should be used as a source of information on what can go wrong in a process, as well as to obtain a better understanding of the associated risks. Implemented preventative measures should also be explained, e.g. the reasons for not releasing effluent into the surrounding areas.
  125. Refresher training should be provided at least every three years and more often if necessary, to each employee involved in operating a process to ensure that the employee understands and adheres to the current operating and environmental procedures of the process.
  126. Encourage employees to be part of the environmental BMP framework by introducing some sort of suggestion box with an incentive scheme for suggestions that can be implemented to improve the protection of the environment.

#### 4.4.2 Develop Production Process Flow Sheets and Measure Sources of Pollution

**Intent:**

It is easier to identify and prioritise the processes and production units which can be sources of pollution and where implementation of BMPs are required if the process flow of the different production processes is available.

127. The first step is to do a thorough investigation to gain knowledge of the industrial processes and the alignment with the governance BMPs. In other words, to determine, for example, that due to the type of the discharge permit, total recovery and reuse of wastewater generated in the plant are required.
128. Detailed production diagrams of all the processing steps of the different production units should be developed, if not already available. A sound knowledge of all the characteristics of each production process used in a plant is absolutely essential to

any effective planning and implementation of BMP for raw product, water and effluents.

129. During the various production processes mechanical action, as well as water, acts vigorously on the raw product, thus forming an effluent containing raw product particles in a wide range of sizes. These particles, called Total Solids (TS), are classified according to their size and their solubility as Total Suspended Solids (TSS) or Total Dissolved Solids (TDS). These sources of effluent generation should be identified and the BMPs for pollution prevention at source detailed later, should be applied.
130. The most important requirement is to analyse the composition of the effluents generated by the processing plant in order to estimate the degree of pollution. These analyses are done to provide the physical and chemical (i.e. physicochemical) characteristics of the effluents. Section 3.3.4 describes the steps industry should follow in order to measure this pollution. These include the measurement of the volume of effluents generated, the physicochemical characterisation of the generated effluents and the calculation of the quantity of pollutants produced.

#### 4.4.3 Water Quality Requirements and Water Mass Balance

**Intent:**

The intent of using a water mass balance is to identify the quality of water required by a specific process. One of the biggest mistakes made by many industries is to use unnecessary high quality water for the different processes, where lower quality waters would have sufficed.

131. The South African Water Quality Guidelines, developed by the DWAF should be studied to ensure compliance to all legal requirements. A good relationship with the regulatory authorities should also be established to ascertain the correct application of the minimum requirements of these guidelines.
132. Refer to Section 3.3.5.4 and 3.3.5.5 to develop BMPs for specific production processes. Tables are used to compile data in order to allow the formation of input/output inventories for a given period of production. The actions required, are to enter all the steps of the production process, including a list of the products used in each one of the steps, to determine the quantity of water and products used and to determine the characteristics of the effluents generated. Table 3.3 classifies the water streams and Table 3.4 indicates the effluents generated to assist in identifying problematic areas in terms of water consumption and generation of effluents and establish the distribution and relative importance of the streams of potable water and effluents.
133. Different users with different quality requirements should be identified. Different

quality waters should be made available to different users by recycling and reuse of the waters in the water mass balance. (Also refer to the BMPs under section 4.4.6 for recycle and reuse of water)

134. Summarise the different quality requirements for different types of water uses in the installation under investigation. It is easier to identify and prioritise the processes and production unit which may be sources of pollution and where implementation of BMPs is required if the process flow indicating the information on the water mass balance and concentrations of products used and generated for each production process, are available. This is also applicable to dissolved and suspended matter within the product streams. A wastewater characterisation analysis should be conducted on all effluent streams originating from different production processes to determine distinct quality differences.
135. The different quality requirements should be evaluated in such a way as to collect and treat the wastewater streams with similar characteristics in a separate process as part of an optimal recovery and recycle strategy.
136. While defining the appropriate water balance for recovery and reuse the following key issues should be considered:
  - ✚ The first issue to take into account relates to water losses associated with in-plant activities due to evaporation, transportation, etc.
  - ✚ The second issue to take into account is that losses associated with the treatment of the generated wastewater flows as evaporation and sludge should also be evaluated.
  - ✚ Water is not only used for production processes and domestic purposes, but also as cooling water make-up and boiler water make-up and these should be included in the water mass balance.
  - ✚ Water for domestic usage should be supplied from potable water.
  - ✚ Treated cooling water discharge should primarily be used to meet the cooling water requirement.
  - ✚ In summer and favourable weather conditions the treated domestic wastewater can be utilised for alternative purposes such as irrigation after undergoing the required treatment.
  - ✚ In all other periods and conditions where the domestic water might be polluted, the effluent of the domestic wastewater treatment plant should be directed to a treatment facility for recovery and reuse in plant operations. This treated wastewater should, for example, be used primarily as process water, subsequently as cooling water input and then as deionised process water.
  - ✚ Part of the treated domestic effluent can be used in facilities such as toilet flushing.
137. Refer to Figure 3.2 in Section 3.2.6 for an example of a Water Mass Balance diagram.

#### 4.4.4 Reduce Water Consumption

**Intent:**

The intent is to establish BMPs to reduce the consumption of freshwater in a processing plant and consequently the volume of the effluent produced without affecting the quality of the final product.

138. The first BMP identified under the Water Quality Requirements and Water Mass Balance requires the compilation of data in tables. These tables should now be used to establish BMPs for a reduction in water use consumption.
139. This first and crucial phase in the implementation of BMPs for freshwater is to understand how and why this water is used in the process, to quantify the volumes used (in litres or m<sup>3</sup>), and to properly visualise the type and the volume of effluents that will thus be generated. Tables 3.3, 3.4 and 3.5 which you would have created, will contain the information necessary to perform this analysis/review. A critical analysis of these results, compiled in Table 3.6, will help you identify the most obvious over-consumption of water.
140. The objective of the second phase is to identify all unnecessary sources of freshwater loss, in other words, all the quantities of water that are not used at the time of production (pure wastage). Create a sub-team that will be tasked to inspect meticulously all your installations (production and auxiliary zones) and to note, among others, the following problems:
- ✚ water losses caused by leaks from pipes, hoses, taps and pieces of equipment;
  - ✚ automatic spraying maintained in operation on the production line during breaks and production shutdown periods, as well as in the sanitary zones; and
  - ✚ pipes and taps from which water runs needlessly between periods of use.
141. It is important to compile a report outlining the work done and containing guidelines aimed at solving such problems permanently. The persons responsible for each sector (production supervisor, maintenance team supervisor, etc.) must be advised of the findings and decisions made, because they are the ones who will ensure that corrective actions will be taken. The work team will have to prepare a programme of education and awareness for the employees as well as a long-term follow-up programme.
142. The objective of the third phase is to reduce the volume of freshwater used during the essential steps of the production process. In order to realise this simultaneously difficult and important phase of the project, it is recommended to complete Table 3.6 in consultation with personnel who have a sound, practical knowledge of the work methods and technologies used, while using the general advice given below as a guide:
- ✚ identify the sources and/or probable causes of the problems detected in water

- management;
  - ✚ list the preventive measures that can be applied to decrease the volume of water used;
  - ✚ discuss among yourselves the feasibility and the cost of each proposed change;
  - ✚ make sure that the measure envisaged will conform with the company's standards; and
  - ✚ identify the priority of execution of the proposed change.
143. Identify the steps of the production process that consume relatively more water than others. These process steps are important and should be explored further. Most of the guidelines presented below are aimed specifically at reducing the consumption of water in each step individually, but some of the remaining have a more general application:
- ✚ install a system to measure the volume of water used (flow meters), particularly at processing steps and equipment that necessitate large quantities of water;
  - ✚ check the volume of water used regularly (daily) and record this information;
  - ✚ install valves in order to allow better control of the water flows;
  - ✚ install nozzles that will enable reduction of the volume and pressure of water in the spraying or automatic sprinkling (continuous and periodic) systems of the production lines; and
  - ✚ install solenoid valves to automatically stop the supply of water during periods of work stoppage.

#### 4.4.5 Pollution Prevention at Source

**Intent:**

Many industries that need to implement measures to comply with discharge requirements have an “end of pipe” thinking as solution for ZED. There is not enough effort to examine what could be achieved at the effluent sources in terms of reduced flows, less pollutants and internal reuse at or near the source.

144. There are many case studies of cleaner production available to assist industries to be more profitable as well as *cleaner* by identifying areas of inefficient use of resources and poor management of wastes by focussing on the environmental impact of industrial processes. Refer to Section 2.3.3.1 for an example of what should be included in such a methodology.
145. Implement operating procedures where storm water pollution may be eliminated by preventing unpolluted water from coming into contact with operational areas exposed to pollutants.
- ✚ Relocate processes indoors to prevent rain from coming into contact with

- operational areas. The reverse should also be implemented where pollutants should be kept away from the areas that will come into contact with storm water.
- ✚ Prevent storm water from coming into contact with contaminated water to reduce the concentrations of pollutants in the storm water.
  - ✚ Change procedures which were accepted in the past and allowed polluted waters to enter the storm water system.
146. Criteria and practices for the storage of raw materials, by-products, products and also materials used during construction should be developed. The key is to plan your storage in such a way as to prevent contact with storm water or any other effluent and to install drains that lead to treatment facilities. Special requirements should be adhered to in the storage of hazardous materials.
147. Identify areas which use water excessively. These areas would most probably be responsible for the generation of large volumes of effluents and will in many instances also be the bigger sources of pollution. These areas will therefore institute the biggest opportunity of implementing pollution prevention measures. Review options for reducing effluent flows and concentrations at source or for using local treatment and recovery technologies.
148. Implement practices to reduce the potential pollution in coating processes. These practices should include the storage, application and disposal of such products.
- ✚ Prevent spillages from entering the storm water system.
  - ✚ Store coating products in a fire-resistant enclosure with an impervious floor and within a bunded area to contain any spillages.
  - ✚ Implement measures to recover and recycle the various solvent products.
149. Implement practices to facilitate the safe disposal of waste fluids which should include its storage, separation, on-site processing and off-site disposal to reduce the possibility of accidental spillages. Spillages should also not be able to enter the storm water systems.
150. Implement spill prevention, control and countermeasure contingency plans. The contingency plans should be site specific and should include the causes of the spills as well as the remedial actions of the responsible cleanup team. There are various documents that could be consulted to assist in the development of a contingency plan.
151. Maintenance and housekeeping practices should be implemented to reduce the possibility of cross contamination of effluents and waste streams between different activities. The necessary environmental awareness should be fostered to ensure ZED compliance would not be jeopardised by poor maintenance or housekeeping at source.

#### 4.4.6 Effluent Separation, Recycling and Reuse of Water

**Intent:**

Relative clean storm water and the various grades of contaminated effluents from different processes are in many instances discharged into the same infrastructure before eventually being discharged into the receiving environment. It is important to carefully plan the discharge strategy and the importance of stream separation when identifying effluents for reuse and recycle and for assessing effluent that should be treated to acceptable levels before being discharged.

152. Identify and categorise effluents that are discharged and develop a strategy to use it in lower quality applications (after treatment, should that be required). Applications that do not always require such high quality waters are heating, cooling and quenching.
153. It is important to use the water mass balances to identify the quality of water required by a specific process. Different quality waters can be made available to different users by recycling and reuse of the waters in the water mass balance. Infrastructure should be made available to ensure the different quality waters are separated and routed to the required and identified treatment facilities and finally to the required users.
154. When recycling water, the TDS, alkalinity, hardness and other chemical compositions of the water will be affected. Although water consumption can be reduced by recycling, the number of cycles should be optimised to ensure the concentration of these constituents does not form mineral deposits in the water systems.
155. An important consideration in recycling industrial water is the cost of treating the wastewater to the required level, including the cost of new or additional pipes and pumps, as compared to the cost of using freshwater as supply. A risk matrix with the different options for water uses should be developed to assist in decision making.

#### 4.4.7 Use of Chemical and Hazardous Products

**Intent:**

Most of the industries in South Africa use some chemicals and the use of chemical and hazardous products can harm the environment if not managed correctly. The management of chemical and hazardous products should also take into consideration the regulations related to its use.

156. The user of chemical and hazardous products should follow the manufacturers' instructions and abide by the governmental regulations in this regard.

157. The chemical composition of chemical products should be taken into consideration when evaluating which to use. Environmentally friendly products should be the preferred alternative.
158. The quantities suggested by the manufacturer should not be exceeded.
159. Practices should be implemented to reduce the impact of uncontained spills. The storage of chemicals and hazardous products should have a suitable containment infrastructure and systems to prevent overflow of tanks and containers.

#### 4.4.8 Residues Management

**Intent:**

It is important to identify the processing steps that are problematic in terms of residue generation and management and to increase the options for recovery and reuse.

160. Refer to Table 3.3 and Table 3.4 of Section 3.3.5.5 and establish a grid of the residues generated as input into the residues portion of Table 3.4 and a grid classification of the raw product that is found in the effluent in Table 3.5. This should be based on the TSS to determine the degree of contamination. The following critical points should be considered in the application of residues management BMPs:
  - ✚ the quantity of residues generated;
  - ✚ the physical state of the residues generated;
  - ✚ the quality of the residues generated;
  - ✚ the storage conditions of the residues; and
  - ✚ the duration and intensity of contact between the residues and water.
161. A good practise is to include the different residue streams on the process flow diagrams of the different production plants.
162. Implement work procedures to force employees to consider residues as a raw product with value adding features instead of a waste that must be discarded.
163. Investigate the possibility to recover the residues.
164. Draw up a table to categorise the preferred storage and disposal BMPs for wastes and also to indicate if the waste can be recovered and if it is hazardous or not.
165. Develop residue handling and storing practices that will ensure ZED compliance is adhered to at all times.

#### 4.4.9 Treatment Technologies

**Intent:**

Treatment technologies should be identified and developed to implement the required

recycling, reuse and treatment of effluent before it is discharged into the neighbouring environment.

166. Refer to the report by the U.S Department of the Interior Bureau of Reclamation published in April 2008 (Desalination and Water Purification Research and Development Program Report No. 149 - Evaluation and Selection of Available Processes for a Zero-Liquid Discharge System for the Perris, California, Ground Water Basin). The table of contents of the report is included as Appendix A and contains a wide range of existing and emerging water treatment technologies for the design and implantation of a ZED plant. The following technologies were included but the report should be studied to form a comprehensive decision making matrix:

- ✚ reverse osmosis (RO),
- ✚ electrodialysis reversal (EDR),
- ✚ forward osmosis (FO),
- ✚ membrane distillation (MD),
- ✚ seeded RO,
- ✚ slurry precipitation and recycle reverse osmosis [SPARRO), and
- ✚ brine minimisation techniques, including brine concentrators, crystallisers, and evaporation ponds.

167. The relevance and application of other treatment technologies should be explored and some of the technologies discussed in the literature study include ultra-filtration, evaporation, phase separation, chemical precipitation, biological treatment, dissolved air flotation and pH adjustment technologies.

168. Attend workshops that will provide fundamental knowledge on effluent treatment technologies and also share the latest innovations and case studies on effluent treatment technologies. Decide on workshops that identify the different effluent treatment systems, describe the basic chemistry in effluent treatment, cover the design and installation of these systems and also apply BMPs through the latest technologies.

#### 4.4.10 Emergency Plans for Unplanned Releases

**Intent:**

Establish pro-active procedures to be prepared when unplanned releases of effluents are the only option. Employees should be familiar enough with these emergency procedures to react unhesitatingly when the situation arises.

169. An emergency response team should be selected to respond to emergency releases of effluents and hazardous chemicals, including small planned releases. All employees

- should know which people to notify within the company and outside parties such as government departments, and these people should then be notified as required.
170. The team should establish and implement an emergency action plan for the entire plant in accordance to the provisions of international standards. In addition, the emergency action plan should include procedures for handling small releases.
  171. Do an assessment of the emergency situation.
  172. Consider all health and safety precautions.
  173. Consider the impact on the environment and the neighbouring communities.
  174. Evacuate the affected areas and isolate all affected equipment.
  175. Immediately implement procedures to prevent further contamination and releases.
  176. Do assessments of the remedial actions required and implement these remedial and maintenance actions.
  177. Thoroughly clean and flush the repaired systems.
  178. Put the systems back in operation.
  179. Ensure the required clean-up actions are done quickly and efficiently.

#### 4.4.11 Establish Verification Measures

**Intent:**

Verification measures should be in place to evaluate not only the environmental but also the actual performance of industrial plants.

180. Compile a table similar to Table 3.7 (refer to section 3.3.5.6) to register the initial and final data and to verify the BMPs on a continuous basis.
181. The data and information registered in Table 3.7 should also be used as tools to make predictions linked to future production processing activity needs. The volume of water that will be used, the quantity of products that will be generated, as well as the volume of effluents and quantities of pollutants that result should be established.
182. Routine check-ups of the BMP performance should be implemented. The stability of the verification measurements in relation to final measurements, will confirm the proper operation of the BMP. The opposite can demonstrate a lack of control and/or a lack of continuity in the application of the BMP.
183. Implement record keeping practices to verify performance in carrying out the BMPs. Include deficiencies identified, improvements implemented, water quality discharged and other checklists to ensure compliance with the necessary legal requirements.
184. A summary of the BMPs selected as appropriate to a specific processing plant should be issued to all employees and contractors and posted on notice boards to induce continuous responsiveness to the different situations encountered on a daily basis.
185. Assign inspection teams with different roles and responsibilities and implement audit

systems to demonstrate the effectiveness of the BMPs to attain ZED in the South African industry.

186. Implement a run-off modeling or catchment modeling system to indicate possible changes in impact for the hydrological situation pertaining to a specific area. Take into consideration the changes in site behaviours due to the implementation of mitigating measures, construction of new plants, extreme weather conditions or major plant upsets.
187. Implement a user-friendly dynamic (not historical) water system simulation model to verify the actual performance of the total holistic water system within industrial plants.

#### **4.5 Conclusion**

This BMP framework will enable industry to develop their own BMPs Manual which should be specific to their operational and environmental requirements. The implementation of these BMPs should demonstrate compliance to the ZED requirements in the South African industry. The BMPs Manual should also be a live document and should be updated with new BMPs generated by the lessons learned and practices applied in industry, by new and improved technologies and procedures and also those due to changes in the regulations and specific licence requirements.

Chapter Five is a case study of the Mittal Steel plant in Vanderbijlpark. The BMP framework developed in this chapter is validated in Chapter Six against the BMPs applied by Mittal Steel to bring about their ZED compliance

## CHAPTER 5 ZED CASE STUDY: MITTAL STEEL, VANDERBIJLPARK

### 5.1 Introduction to Case Study Approach

Instead of using large samples and following a rigid protocol to examine a number of variables, a case study approach involving an in-depth examination of the practices applied in industry will be evaluated.

“Case study research is a time-honoured, traditional approach to the study of topics in social science and management. Because only a few instances are normally studied, the case researcher will typically uncover more variables than he or she has data points, making statistical control (e.g. through multiple regression) an impossibility. This, however, may be considered a strength of case study research: it has the capability of uncovering causal paths and mechanisms, and through richness of detail, identifying causal influences and interaction effects which might not be treated as operationalized variables in a statistical study. As such it may be particularly helpful in generating hypotheses and theories in developing fields of inquiry.” (Garson, 2008:1)

In an article published by Lynn Davey (1991) a case study is described as a method of learning about a complex instance through extensive description and contextual analysis. “The product is an articulation of why the instance occurred as it did, and what may be important to explore in similar situations.” (Davey, 1991.)

Chapter Five presents a case study of the state of affairs at the Mittal Steel plant in Vanderbijlpark and the process the organisation followed to reduce the intake of water and eliminate the discharge of effluent from their boundaries. The BMPs applied by Mittal Steel in compiling their environmental master plan and the execution of the project to bring about Mittal Steel’s ZED compliance is addressed.

### 5.2 Reasons for Choosing Mittal Steel Vanderbijlpark as Case Study

**Note:**

ArcelorMittal, the world’s top steel producer, owns just over half of ArcelorMittal South Africa and changed its name from Mittal Steel South Africa Limited in 2007 to ArcelorMittal South Africa Limited. Due to the fact the case study concentrates on the company’s ZED practices and implementation projects to ensure ZED compliance by end 2005, the name Mittal Steel South is used in the dissertation because it was the company’s official name at the time.

“Mittal Steel South Africa Limited, which had been known as Iscor Limited since June 1989 and changed its name to Ispat Iscor Ltd on 17 August 2004 and changing it again on the 1<sup>st</sup> of March 2005 to Mittal Steel South Africa Limited, was established in 1928 to promote industrialisation in South Africa through the production of steel for the growing manufacturing industry”. (Mittal Steel, 2008.)

The damaging effect of industry on the environment is one of the greatest challenges facing industry throughout the world. “Although industry accounts for only approximately 16% of the direct water use in South Africa, it often produces effluents, which contain toxins and other damaging pollutants. The damaging effect of industry in South Africa is compounded by a low availability of water.” (Brouckaert and Buckley, 2003:1.)

The water quality in South Africa’s Vaal River varies from poor in the highly developed areas to good in the less developed areas. “The water quality is impacted on by point discharges from industries, wastewater treatment works, mine dewatering, irrigation return flows and diffuse sources such as run-off from mining and industrial complexes, agriculture and urban areas. The area is also subject to atmospheric deposition due to emissions from coal fired power stations and industry in and around the catchment.” (DWAF, 2004: v.) The Vaal River is divided into three Water Management Areas and the release of pollutants into the Vaal River has a wide-ranging effect. “The cascading characteristic of the three Vaal Water Management Areas (WMAs) has the consequence that the water quality of the main stem of the Vaal River in the downstream WMAs is impacted on, not only by the activities in the WMA itself, but also by the water received from upstream. In addition, the water quality in the Vaal River will also impact on the water quality of the Orange River in the Lower Orange WMA. Due to this inter-dependency it was identified that the current process of managing water at sub-catchment level should be expanded to integrate management activities across sub-catchments, to meet shared water quality objectives in major tributaries as well as in the main stem of the Vaal River.” (DWAF, 2004: v.)

Mittal Steel South Africa produces flat steel products at its steel plants at Vanderbijlpark and Saldanha. The Mittal Steel Vanderbijlpark plant, an integrated steel works situated near the Vaal River south of Johannesburg, is one of the world’s largest inland steel plants and the largest supplier of flat steel products in sub-Saharan Africa. There are significant potential releases of pollutants during the various stages in the steel making process.

The total water requirement of the iron and steelmaking processes is of the order 100-200 m<sup>3</sup> per tonne of product supplied, primarily, by integrated recycling systems. From the viewpoint of pollutant control a high recycling ratio is preferred; however, factors such as build-up of hardness and conductivity require that an optimum recycling ratio is

determined from a total water system analysis. The extensive recirculation in indirect and direct cooling systems reduces the total water intake to 2.4 percent of the requirement of a once through system. (UN, 2002).

The researcher was the Project Manager of the project to construct a new Main Treatment Plant (MTP), the upgrading of existing treatment plants and to separate the storm and process water blow down systems and redesign the water distribution network and water applications to cater for the newly reclaimed water. The main drive and benefit of the MTP was to reach the objective of Mittal Steel Vanderbijlpark of not releasing any effluent water into the environment and thereby contributing to the DWAF's objective to lower the salinity in the Vaal River catchment area.

### 5.3 Mittal Steel at a Glance

Mittal Steel South Africa is South Africa's largest steel producer, producing more than 7 million tonnes of liquid steel per annum. As mentioned before the plants in Vanderbijlpark and Saldanha produce flat steel products and its Newcastle and Vereeniging plants produce long steel products.

Mittal Steel Vanderbijlpark was established in 1943 and specialises in the production of flat steel products from primary raw materials. The Mittal Steel Vanderbijlpark plant is one of the world's largest inland steel plants and the largest supplier of flat steel products in sub-Saharan Africa. This plant produces nearly 4 million tonnes of flat steel products per annum, including hot rolled steel in coil and plate; cold rolled; hot-dipped galvanised; electro-galvanised; colour coated and tinsplate coil and sheet. (Mittal Steel, 2005)

Figure 5.1 illustrates the different production processes that take place within Mittal Steel South Africa. Mittal Steel Vanderbijlpark consists mainly of:

- ✚ Sinter Production
- ✚ Direct Reduction
- ✚ Coke Ovens
- ✚ Blast Furnaces
- ✚ Basic Oxygen Furnaces
- ✚ Electric Arc Furnaces
- ✚ Continuous Casting
- ✚ Milling
- ✚ Sheet Coating

By its very nature, the various processes produce residue streams which are either reused

in the same or other processes, disposed of to outside interests as raw materials or have to be managed as residue. The latter activity has to comply with a number of regulatory requirements administered by different state departments.

It cannot be denied that the steel manufacturing process can potentially be responsible for significant pollution of the environment if their environment management systems are not in place. In a very controversial report on Mittal Steel's pollution history (Cock and Munnik, 2006:10-11) the following table indicated the main pollutants arising from the steel making process.

**Table 5.1: Pollutants during Steel Making Process**

<b>Steel making process</b>	<b>Most significant potential releases of pollutants during stages in the process of steel making</b>
Sinter plants (which produce pellets of iron)	Release particulates, heavy metals, sulphur dioxide, nitrogen oxides, carbon dioxide and polychlorinated dibenzo-p-dioxins and polychlorinated dibenzofuran (PCDD/F), which are carcinogenic.
Coking plants (where coal is made into coke)	Release particulates, sulphur dioxide, nitrogen oxides, raw Coke Oven Gas, benzene and PAHs to air: oils and wastewaters containing phenols, cyanides and ammonia.
Blast furnace iron making	Release iron fumes (particularly if no cast house fume abatement exists), carbon monoxide, sulphur dioxide and carbon dioxide to air; and wastewater containing iron and heavy metals. Bleeder openings can be noisy and release carbon monoxide and particulate.
Basic oxygen steel making	Release iron fumes, heavy metals and carbon monoxide if they escape collection; and carbon dioxide.
Electric arc steel making	Releases iron fumes, other metals. PCDD/F and carbon monoxide into air; wastewater; fume dust to landfill; and noise.
Reheat furnaces and on-site power plants	Release sulphur dioxide and nitrogen oxides, particularly when burning fuel oil and large amounts of ash in the case of coal-fired power plants.

(Cock and Munnik, 2006:10-11)

# Process Flow at Vanderbijlpark Steel

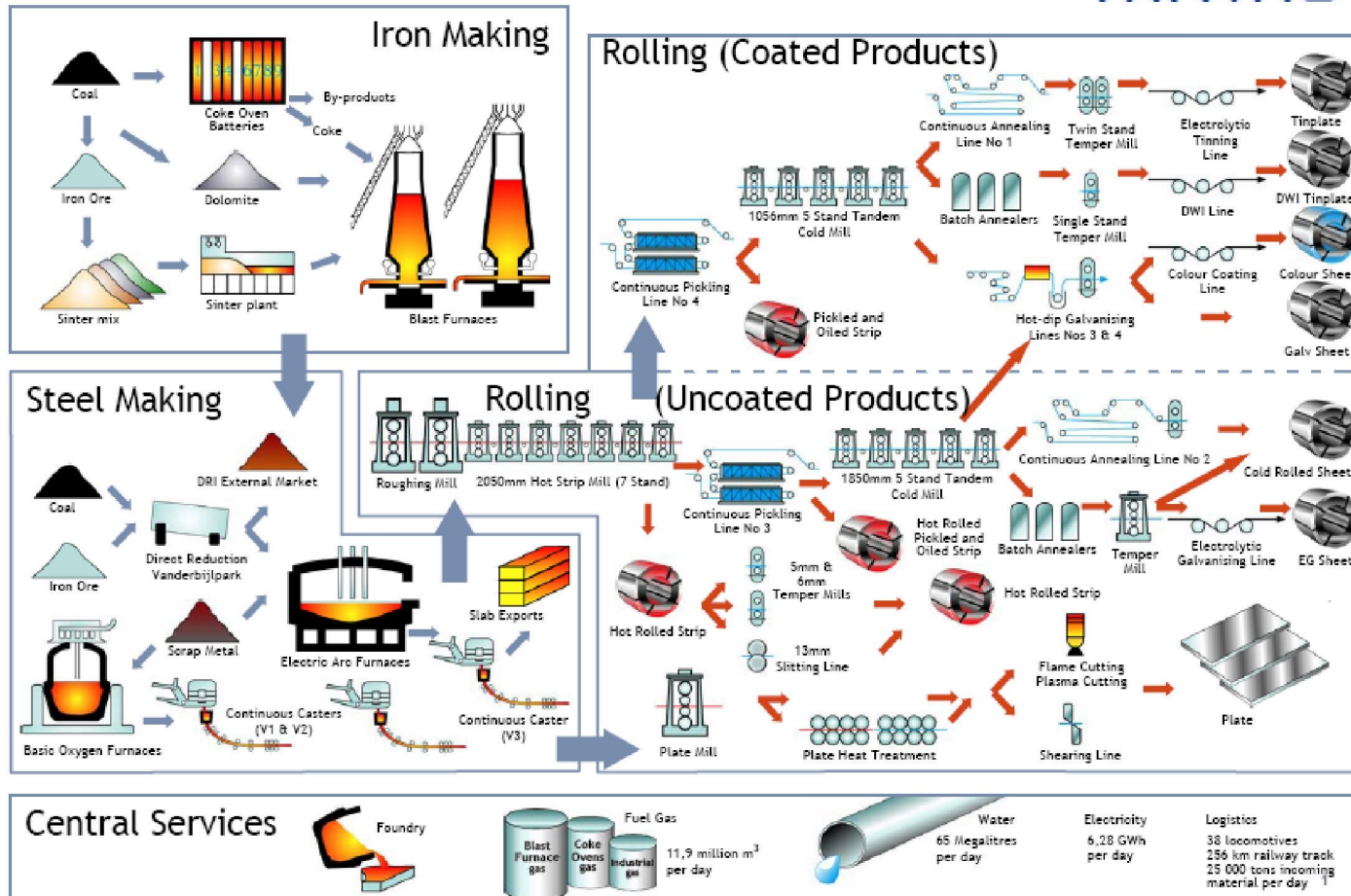

Figure 5.1: Process Flow at Vanderbijlpark Steel

(Mittal Steel, 2005)

## 5.4 Mittal Steel and Corporate Governance

Mittal Steel complies with all material aspects of the Code of Corporate Practices and Conduct as contained in the King II Report on Corporate Governance for South Africa 2002, as a minimum standard. In line with the King II report and the JSE requirements, a reporting system was developed and The Board of Mittal Steel South Africa endorses the Code of Corporate Practice and Conduct as set out in the King II Report on Corporate Governance and has satisfied itself that Mittal Steel South Africa has complied throughout the period with the King II Code.

Mittal Steel recognises that there are a number of parties who are affected by its operations and who have an interest in their affairs. For this reason even the annual reports cover a number of non-financial issues in addition to pure financial information. The objective is to present a balanced and understandable assessment of the company's affairs to stakeholders. The corporate affairs department plays an important role in ensuring regular communication with shareholders and the investment community. The Mittal Steel website, [www.mittalsteelsa.com](http://www.mittalsteelsa.com), is a valuable tool in communicating with interested parties. It covers a variety of issues concerning the company and operations. The section on corporate governance contains a number of relevant documents, including the annual report, the board charter, terms of reference of board committees and many others. Mittal Steel also included their progress towards ZED in the different annual reports.

The Mittal Steel annual reports since 2004 encompass many aspects of modern management principles. Mittal Steel South Africa is an active member of the International Iron and Steel Institute (IISI) and contributes to and supports its policies and initiatives on sustainable development. Specific initiatives are aimed at achieving objectives with regard to sustainable development and are covered extensively within the sustainability report section contained in this report. These include:

### Risk Management

- knowledge sharing,
- skills development,
- talent management,
- HIV/Aids, and
- employment equity.

### Human Resource Management

### Safety, Health and Environment (SHE) Management

- safety,
- occupational health and hygiene,

- environment,
- commitment to sustainable development.
- ✚ Corporate Social Investment
- ✚ Black Economic Empowerment
- ✚ Corporate Governance
  - internal audit,
  - code of ethics,
  - stakeholder communication,
  - insider trading.
- ✚ Technology Leadership

**Table 5.2: Mittal Steel Corporate Social Strategy**

“ArcelorMittal South Africa accepts that social development cannot be the sole responsibility of government. Through public-private sector partnerships the company engages its skills and resources to broaden the base of the economy and ensure that it serves the broader community. ArcelorMittal South Africa’s CS strategy is underpinned by the following principles:

- ✚ Addressing socio-economic imbalances;
- ✚ Contributing to meaningful transformation;
- ✚ Aligning objectives with government programmes such as ASGISA (Accelerated & Shared Growth Initiatives of South Africa);
- ✚ Empowering historically disadvantaged communities to become self-sufficient; and
- ✚ Promoting employee participation in social projects.

Our focus areas are:

**Primary**

- ✚ education with special emphasis on the development of human potential in the fields of mathematics, science and technology through a variety of initiatives
- ✚ job creation and poverty alleviation
- ✚ health & safety
- ✚ BBBEE & SME Development

**Secondary**

- ✚ sports development
- ✚ arts & Culture
- ✚ environment
- ✚ social promotion

With this said, ArcelorMittal South Africa has a long-standing commitment to social transformation and capacity building and millions have been invested with charitable and education organisations involved in a variety of community development programmes”

(Mittal Steel, 2008)

## 5.5 Mittal Steel's Commitment to a Cleaner Environment

Mittal Steel Vanderbijlpark manages its environmental issues as part of its core business and has implemented environmental management systems that comply with the international ISO 14001. As part of the commitment of Mittal Steel Vanderbijlpark to the creation of a safe and healthy environment and its endeavours to conduct its business in an environmentally sound and acceptable manner, they made a commitment to the DWAF to move towards a ZED plant by the end of December 2005.

The Mittal Steel ZED principle aims to re-circulate the process water as many times as practicably possible to build up the salt level; then to purge a portion of the salt-laden water, treat it, and return it to the system.

In the controversial report on Mittal Steel's pollution history, named *Throwing Stones at a Giant* (Cock and Munnik, 2006) the history of Mittal Steel's pollution practices are highlighted and more interestingly the report concentrated on Mittal Steel's denial of responsibility for the pollution caused by the processes. The case studies of the people of the neighbouring community dramatically portray the impacts and outcomes of water pollution and how a community collapsed due to Mittal Steel's reckless pollution of the environment. The repercussion of this impression by the public makes the need for a successful ZED implementation imperative.

### 5.5.1 Mittal Steel's progress towards ZED

Below follows a roadmap of milestones to indicate the progress made towards meeting the ZED requirements:

- ✚ Mittal Steel's executive management made a commitment to the Minister of DWAF in 1997 to achieve ZED for process water at its Vanderbijlpark plant by December 2005.
- ✚ The investigation of projects commenced in 1997 to build a series of plants to handle all the effluent of Mittal Steel Vanderbijlpark. However, it was found that these plants would not satisfy all the environmental objectives and would have been costly to build (a water treatment plant of approximately R500 million and Coke Ovens by-products plant of approx R700 million).
- ✚ In 1999 a consulting team under the guidance of Dr O Fourie was appointed to look at a holistic approach to the environmental problems.
- ✚ During 2000 and 2001 a series of short-term ZED measures had to be implemented to comply with the previous DWAF exemption certificate that was replaced by the 2002 water license.

- ✚ During 2000 a joint investigation was completed between Mittal Steel Vanderbijlpark and Sasol to take organically polluted water to Sasol for treatment and return brine water to Mittal Steel. The estimated project operating costs were found to be unacceptably high and the project was mutually cancelled.
- ✚ An Organic Effluent Treatment Plant was perceived (circa 2000) as one of the major components of the necessary water management infrastructure for the Mittal Steel Vanderbijlpark site. In assessing its performance requirements, an overall water management strategy was evolved some years previously. This strategy was updated and adapted to suit the ever-changing requirements of the site and the ever-tightening expectations of the DWAF and other interested and affected parties. The strategy had the specific aim of achieving a zero dry weather effluent flow from the site. This strategy means that as water becomes too contaminated to be usable anywhere on site, it has to be treated and recovered for reuse, with the solid treatment residues suitably rendered harmless or disposed of appropriately. The strategy took the view that, ideally, the recovered water should equal or exceed the highest quality water used at the site; as this would yield the greatest flexibility for reuse.
- ✚ Mittal Steel Vanderbijlpark was issued a license by the DWAF dated 2002-04-02 that allowed continued operations as long as continuous improvements were implemented to reach ZED by December 2005. The Main Treatment Plant (MTP) project was born to fulfil this license requirement.
- ✚ At that time, ZED would be achieved by the containment of mainly organic polluted waters by the Cleaning of Coke Ovens Gas and Water Project and the treatment of mainly inorganic polluted waters by the MTP project. The total cost of these two projects was R500 million and formed part of Mittal Steel's R1 billion capital outlay set aside for environmental programmes.
- ✚ ZED is stated as "No process water from the operation of Mittal Steel Vanderbijlpark is allowed to flow across the Works' boundary."
- ✚ Mittal Steel Vanderbijlpark reached its ZED target on 31 December 2005 by not releasing any effluent into the environment.
- ✚ There is an ongoing drive to address the environmental issues timeously and effectively and Mittal Steel has lately implemented a toll-free environmental complaints line for the public to report any environmental incidents of concern (Anonymous, 2008:26).



**Environmental Complaints reporting:  
Toll free number implemented for ArcelorMittal South Africa Vanderbijlpark Works**

In line with ArcelorMittal South Africa's strategy to address environmental issues timely and efficiently, Vanderbijlpark Works has implemented a toll free Environmental Complaints Line.

**The number is 0800 212 198**

This number is for the use of the public to report any incidents of concern like extensive emissions, noise pollution and other environmental incidents at the Vanderbijlpark Works site.

transforming tomorrow

Figure 5.2: Mittal Steel Environmental Reporting Hotline

(Anonymous, 2008:26)

## 5.6 Mittal Steel Environmental Master Plan

Because of changing legislation, legacy issues, legal action against the Works and increased pressure from state departments during the late nineties, a need to develop an Environmental Master Plan was identified. As stated in the Introduction, it is necessary to explore the BMPs taken by the specialist team to produce the Environmental Master Plan. The Management of Mittal Steel Vanderbijlpark appointed a project team under the leadership of Ockie Fourie Toxicologists (OFT) to develop an Environmental Master Plan to address in particular:

- ✚ documentation of the environmental *status quo*;
- ✚ identification and quantification of all environmental impacts and risks;
- ✚ development of options for the improvement of the risk profile;
- ✚ collation of an integrated plan of action; and
- ✚ development and implementation of an Environmental Monitoring System.

The main project team consisted of local and international specialist to address all the disciplines as required. Specialist studies on all environmental aspects had been carried out. The environmental disciplines that were addressed included specialist studies for the following:

- ✚ residue characterisation (solids, sediments and leachates),
- ✚ geotechnical and soil profiles,
- ✚ geology and ground water,
- ✚ surface water,
- ✚ process effluents,
- ✚ air pollution,
- ✚ ecoterrestrial (plant life and animal life),
- ✚ aquatic ecosystems,
- ✚ noise,
- ✚ visual and aesthetic quality,
- ✚ archaeological and cultural interest,
- ✚ land use capability,
- ✚ socio-economics,
- ✚ public participation and consultation,
- ✚ regulatory and legal requirements, and
- ✚ land zoning.

One of the key objectives of the Environmental Master Plan was to characterise the environment of the Vanderbijlpark Steel study area in an integrated holistic approach. The

current and historical practices and possible contamination had to be characterised during the execution of the baseline studies. The scope of the baseline studies was formulated in a holistic manner to enable its integration to facilitate integrated risk and impact quantification and hence the introduction of management objectives and measures.

The baseline studies for the Master Plan were conducted over a period of two and a half years, starting in July 2000. The findings of the individual environmental aspects were integrated with the identification of all risk factors and the formulation of motivated alternative corrective actions for the identified 10 priority environmental management areas, which were further delineated into 42 business units and the business units were consolidated into logical, geographical and operable zones. The integration process included an activity description per management area and a description of the impacts and risks for each environmental component.

The primary objectives were then formulated and area specific or secondary management objectives were determined. The next step was to identify and formulate alternatives. A first order evaluation and consideration of alternatives was performed. The consideration of alternatives included verification by means of applying technical, legal, economical and environmental criteria. As the integration process unfolded during the course of a series of workshops and specialist work sessions, the more environmentally acceptable and feasible options were identified, formulated and conceptualised.

Mitigating measures and alternative strategic approaches were defined, formulated and developed for the preferred options applicable to each management area. A three stage verification process was conducted which entailed the following:

- ✚ a detailed review of the alternatives as part of the feasibility study phase;
- ✚ a comparative analysis of the base case with the preferred option(s) and the testing of the viability and level of confidence of each option;
- ✚ a detailed feasibility study of the preferred option;
- ✚ a confirmation of the preferred option by consulting the stakeholders; and
- ✚ initiation of the permitting and authorisation processes, required for the implementation of environmental projects.

The preferred options and measures were conceptualised, costs were estimated and an implementation strategy was developed. The prioritisation was a complex but important step during the project. A two level prioritisation process was performed and a matrix evaluation was done during which the environmental management areas were rated and ranked in terms of health and environmental criteria. The criteria inherently encompassed:

- ✚ “Primary criteria
  - Human Health criteria; and
  - Biophysical and environmental criteria.
- ✚ Secondary criteria
  - Risk based management criteria of site specific nature;
  - Criteria to ensure that all environmental effects are taken into consideration in an integrated manner;
  - Criteria to ascertain that the best practicable environmental option is pursued;
  - Criteria to ensure the promotion of sustainable development and continued operations of the Works;
  - Requirements enforced by the regulatory authorities to enhance informed decision making; and
  - Criteria to ensure the effective regulation and management of the implementation of the Master Plan.” (OFT, 2002:60).

The prioritisation process resulted in 4 major projects and more than 200 environmental measures proposed for implementation. Of the 4 major projects the construction of a water plant to achieve ZED by December 2005 was at the top of the list. At the time the estimated cost for a water treatment plant was R150m (base date 2002) out of the estimated total financial provision of R1 445m (base date 2002) for the implementation of the Environmental Master Plan.

## **5.7 The Evolution of the Process Waters Master Plan Concepts**

### **5.7.1 Introduction**

Members of the R. Paxton and Associates Ltd team (RPA) were contracted by OFT to be responsible for the process water part of the Environmental Master Plan.

At the start of the Environmental Master Plan Process (mid 2000), the standards of operation and compliance regarding process waters were poor. The different parts of the overall strategy that existed for improvement and for reaching ZED by 2005 (as had been promised to the Authorities) did not link up adequately, and in places there were serious gaps that would have needed major quantities of additional resources in order to fill the gaps. In particular, the concepts would only have been able to have achieved ZED during dry weather. During wet weather, the majority of the ‘then’ discharges would have been discharged as an admixture with surface waters.

A further major problem with the proposals was the “end of pipe” thinking. There had been

little apparent effort to examine what could be achieved at the effluent sources in terms of reduced flows, less pollutants per unit volume, internal reuse at or near to source, etc.

One thing which must be remembered when one is evolving a strategy for process waters and effluents, particularly in the Highveld areas of South Africa (or other net evaporation regions which are distant from the sea), is that treating Steel Works and other similar effluents to a quality which will be acceptable for discharge into the environment is almost always more expensive than treating that same effluent or process water to a standard which would enable the whole volume to be usable elsewhere on-site. In the light of this generally proven experience and the ongoing tightening of standards to which effluents will have to be treated before they can be discharged into the environment, the concept of moving towards ZED was both a realistic and a pragmatic concept.

Accordingly, RPA (Paxton, 2002a:8) recommended that the identification and quantification of lower grade water consumption users was an essential first step in the process of evolving a cost-effective method for achieving ZED. This was particularly important in the light of the additional volumetric throughputs associated with polluted ground and storm waters that had been identified in previous studies.

In particular, RPA (Paxton, 2002a:9) recommended that the following types of questions needed to be answered:

- ✚ Could partly treated water be used for some lower grade usage so as to prevent or reduce the use of raw water?
- ✚ Are there input streams to the total source of wastewater which (before they mix with the rest) are clean enough to be used elsewhere?
- ✚ Are there individual effluents which contain components which will assist the treatment of other effluents?

RPA proposed that in a suitably holistic approach, with cash flow and value for money at the top of the agenda, a new strategy could be developed which would not only be compliant but also considerably cheaper in terms of both capital and operating costs. To that end RPA, as part of the OFT Environmental Master Plan Team, were engaged to identify a flexible strategy to achieve the ZED objective (Paxton, 2002a:9). Clearly, there was an understanding by all concerned that the relevant water quality criteria would tighten progressively with time. As a result, the fundamental planning and the process designs that were needed in order to achieve ZED had to be such that this progressive tightening could be accommodated by a systematic sequence of upgrades rather than by some form of “start again” approach at some time in the future.

The final Process Water Master Plan by RPA consisted of 2 volumes of 172 and 154 pages respectively.

### 5.7.2 Process Water Master Plan Methodology and Approach

In essence the role of RPA was split into the following elements (Paxton, 2002a:11):

- ✚ Confirm the alternative strategies and objectives outlined in the previous RPA critique of the Organic Effluent Treatment Plant based system.
- ✚ Using direct contact with plant staff plus existing site data, RPA would characterise all industrial water uses (qualities and quantities) and determine the controlling criteria as to the necessary quality requirements via an appreciation of the technology employed. Similarly the potential for change as a result of planned/possible future plant or process changes was evaluated.
- ✚ Review options for reducing effluent flows/concentrations at source or for using local treatment recovery and other technologies.
- ✚ Introduce and refine flow and quality measurement arrangements and accumulate and interpret data as necessary.
- ✚ Run tests and pilot studies for potential reuse/recovery/treatment options (especially for cold and hot mill recycling areas).
- ✚ Develop and update overall water and contaminant balance and integrate with surface water balance.
- ✚ Evolve and rank optional strategies for recycling, reuse and treatment.
- ✚ Review bio-treatability options and define any experimental studies that may be required (desk and literature study plus review of experience from operating facilities).
- ✚ Revisit Organic Effluent Treatment Plant technology and options (as proposed in 2000).
- ✚ Revisit Central Effluent Treatment Plant (CETP) technology/options for upgrade (as proposed in 2000).
- ✚ Review options for existing bio-plant upgrade.
- ✚ Review Options for Terminal Effluent Treatment Plant (TETP) upgrade.
- ✚ Overall integration with surface water, ground water, leachates, air pollution control effluents and any possible future projects.
- ✚ Generate Master Plan definition for process waters inclusive of outline budgets and timescales.
- ✚ Review the proposal with Mittal Steel Management and DWAF and the other interested/affected authorities as required.

The original concepts for the Process Waters Master Plan were evolved during the latter part of 2000 and early 2001. They were drawn together into an overall coherent whole by the middle of 2001. During early 2002 the timetable for achieving ZED by December 2005 necessitated the confirmation of the Process Waters Master Plan so that realistic process designs could be completed and tender documents could be prepared. This necessitated that either specific aspects of the remainder of the Master Plan studies had to be finalised or the existing assumptions that had been made by RPA had to be used. Assumptions had to be made regarding the following areas:

- ✚ The nature of surface waters that would eventually have to be processed.
- ✚ The nature and the capabilities of the infrastructure which would be available on-site for the treatment and disposal of the residues from the ZED infrastructure.

### 5.7.3 Process Water Master Plan Baseline Studies

The RPA baseline studies (Paxton, 2002a) commenced by compiling the following:

- ✚ The on-site water use, consisting of:
  - water consumption rates,
  - water consumption profile, and
  - water use breakdown (by business unit).
- ✚ The functioning of the existing effluent systems (including evaporation dams):
  - the effluent generation sources together with their qualities and volumes for each system;
  - the technology and chemistry of each system;
  - the quality and volume of the final effluent from each system; and
  - the inputs to the different canals within the Works.
- ✚ Identification and characterisation of each effluent that is generated at each individual plant area discharge point and to identify the routing of each effluent into the canal infrastructure. A water balance for the site is provided in Figure 5.3. Note that the drawing is an indicative overview picture that concentrates on the net flows reaching the TETP at that time and as such does not fully represent all the internal water and effluent recycle systems in place at the works.
- ✚ RPA worked closely with the Mittal technical and operational personnel to identify

and characterise each effluent that is generated at each individual plant area. The effluent composition analysis included the aggregated total for all the individual effluents that were obtained from the RPA assessments of individual process areas to obtain a mass balance for the Works.

Baseline study findings per individual active process water related production area were established and consisted of the following:

- the purpose and objective of that specific area in the steel making process;
- the different steps and technologies of the process;
- the chemistry and main elements in the process;
- water utilisation;
- the wastewater sources; and
- the characteristics of all water related systems in terms of the following:
  - a description of the processing steps and the sequence of processing, what the plant and equipment consists of, and what is necessary for:

Lubrication	Cooling of the work and back-up rolls
Cooling of the work, strips and/or backup rolls	Removal of iron-particles
Rinsing	Flushing water
Discharge arrangements	Secondary issues
Techniques for the reduction of wastewater volume and contaminant loading	
Account being taken regarding the overall effluent issues and the overall interests of the site as a whole	

- The technical specification and in particular:

System capacity	Hot water temperature
Standard make-up rate	Cold water temperature
Blow down rate	Cycles of concentration
Circulation rate	Materials of construction
Side stream filtration	Delta T (temperature change)

- The stream analysis in terms of:

Total Hardness	SiO <sub>2</sub>	Phenol	Cr <sup>6+</sup>
Ca Hardness	Conductivity	NO <sub>3</sub> <sup>-</sup>	Zn
P alkalinity	TDS	NO <sub>2</sub>	K
Total Alkalinity	Suspended Solids	NO <sub>3</sub> -N	KMnO <sub>4</sub>
pH	F	NO <sub>2</sub> -N	Cr (total)
Cl	Mn	P	S
SO <sub>4</sub>	NH <sub>3</sub>	Na	CN
SO <sub>4</sub> -S	NH <sub>3</sub> -N	Fe	Sn

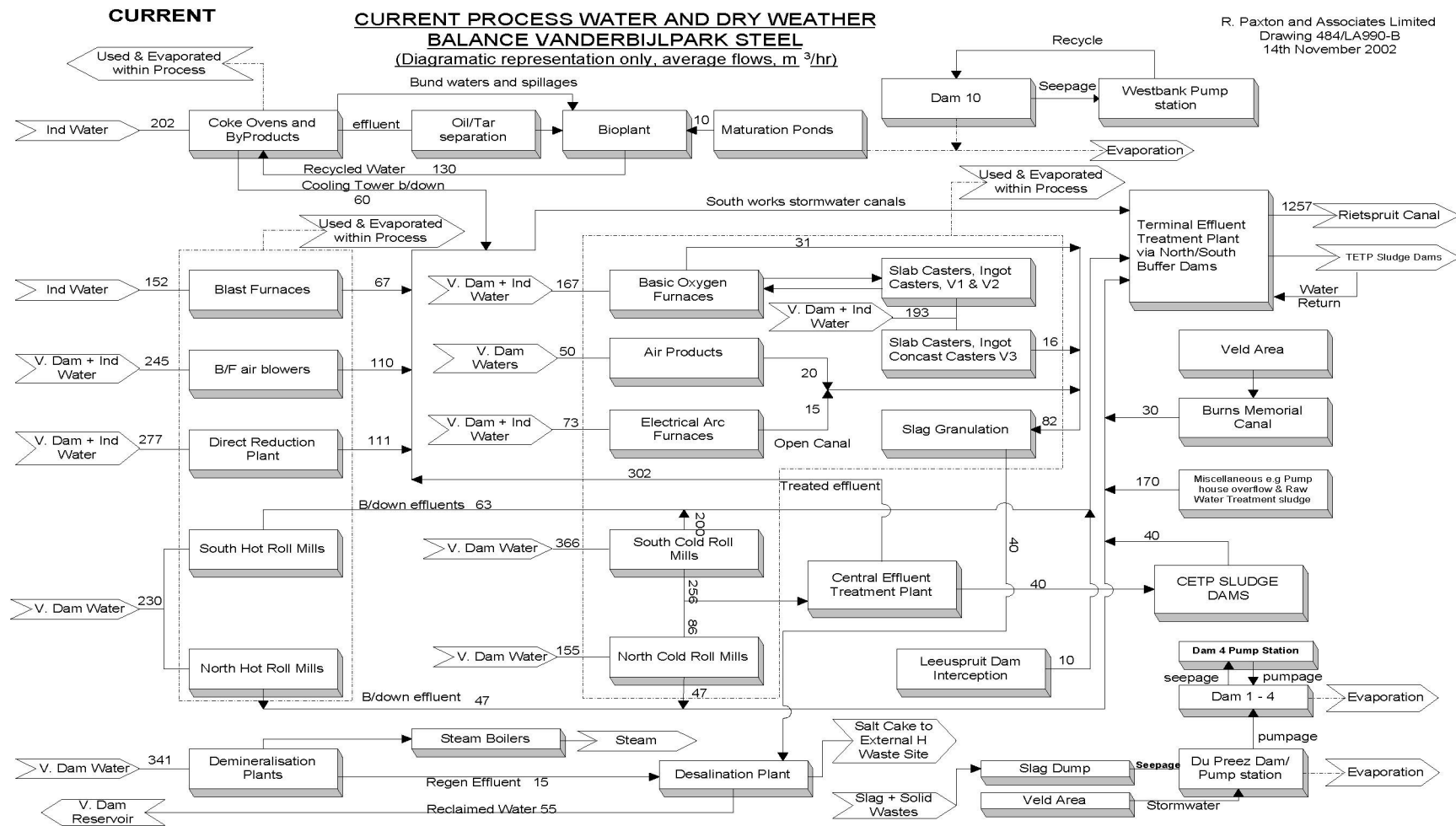

Figure 5.3: Mittal Steel Process Water and Dry Weather Water Balance

(Paxton, 2002b:107)

#### 5.7.4 Process Water Master Plan Strategy

The next important step was that each plant area in turn was described in detail in terms of process effluent derived environmental risk.

In order to reach the ultimate master plan status, it was necessary for RPA to use the data obtained from the baseline studies to evolve a method of collecting, treating and reusing all of the following (Paxton, 2002b:37):

- ✚ all process effluents (both the weak effluents and the strong effluents);
- ✚ all the contaminated ground water;
- ✚ all the contaminated surface water;
- ✚ all spillages and leaks;
- ✚ all leachates and seepages from the dump, from the dams and from stock piles; and
- ✚ all the contaminated waters currently stored in dams, lagoons or tanks.

As a first step in the overall Master Plan Process, all the different effluents from the different production units were characterised. This characterisation included:

- ✚ the source location;
- ✚ the nature and variability of the production process;
- ✚ the water and reagent quality used in that production process;
- ✚ the variability in flow and quality of each effluent during normal production and during power outage, maintenance or other non-normal situation;
- ✚ the potential for changes to that production process, either now or in the future;
- ✚ the significant changes that occurred over recent years, if any;
- ✚ were the nature and status of any existing treatment facilities for these effluents either at source or elsewhere on-site;
- ✚ what was the current discharge/outlet arrangement or route; and
- ✚ the quality criteria or other determinant which required the liquor to be discharged, purged or blown down as an effluent.

In addition, the current water usage arrangements around the site were examined relative to the quality and quantity of water which could be used by each user, if such a quality was available.

#### 5.7.5 Initial Qualitative Findings and Short-term Measures

From the initial qualitative findings a picture emerged of strong process effluents all being

handled by specific plants or infrastructures on the site and weak effluents being discharged by various canal infrastructures to the TETP. A small number of relatively minor discharges from processes (mainly cooling towers and wash down) to the storm water systems were identified. Effluents were discharged into the same infrastructure as that for storm water and there were many areas where there were inadequate means for containing process spillages or leakages. In addition, there were relatively few options for returning any spillages or leaks to process or for routing them separately to appropriate disposal.

As part of the close working relationship between RPA and the Mittal Steel site personnel, a number of measures were pushed through under the OFT team banner to bring about immediate environmental improvement at the site. These short-term measures were of the utmost importance in the overall process water management infrastructure and the development of ZED.

#### **5.7.6 Summary of Mittal Steel Vanderbijlpark ZED Concept**

It has already been mentioned that there was an understanding by all concerned that the relevant water quality criteria would tighten progressively with time and that ZED should be achieved by a systematic sequence of upgrades.

RPA's key role therefore was to look at all the process effluents and process waters and in conjunction with the rest of the overall holistic environmental master plan studies, evolve a more appropriate way of achieving compliance with the concept of ZED. In addition RPA had to define a method by which this ZED could be achieved within the originally agreed time scale of "before the end of 2005".

### **5.8 The Mittal Steel MTP Project**

#### **5.8.1 Introduction**

This section of Chapter 5 will summarise the approach taken from the concepts for the Process Waters Master Plan (Paxton, 2002a & 2002b) to implementation of the MTP project.

As mentioned before, the Vanderbijlpark plant of Mittal Steel had a commitment to be a ZED plant by December 2005. Treated rainwater will still be allowed to leave the site. To achieve this, the rainwater and process water collection systems have to be separated and certain water treatment plants need to be upgraded and modified. Finally only treated rainwater would be allowed to leave the site, while all process effluents will be treated and recycled back to the various processes on the site.

At the time the TETP treated all the effluent before it was discharged. This effluent included both process water and rainwater.

### **5.8.2 Governance and Management of the MTP Project**

The execution of the MTP project was managed by a project team taking the four core project management functions of scope, quality, time and cost through the four facilitating functions of risk, human resources, procurement and the required communication practices to attain the ZED milestone of December 2005.

The MTP project was divided into the following four manageable subprojects and short term measures which were contracted out to experienced contractors for the design, detail engineering, contractors project management, procurement, construction commissioning and testing of the different plants:

- ✚ The MTP project which included the upgrade of the TETP to become the Main Treatment and Dewatering Plant.
- ✚ The upgrade of the CETP Project.
- ✚ The separation of storm water and effluent and the collection and redistribution of effluents.
- ✚ Emergency dam project.
- ✚ Short-term measures to bring about immediate environmental improvement at the site. These short-term measures were vital in eventually achieving ZED compliance and alleviated the environmental impacts of historical practices.

The following section will give a brief description of the EIA process and each of the four projects.

### **5.8.3 High Level Description of the Scope of the MTP Project**

#### **5.8.3.1 The EIA Process**

Mittal Steel had to follow the full EIA process under the *Environmental Conservation Act 73 of 1989*. The relevant authority, the Gauteng Department of Agriculture, Conservation and Environmental Affairs (GDACE) had been consulted from the outset of this study and was engaged throughout the project process. As could be expected, the public participation process caused several delays due to the neighbouring community demanding answers to all the current and historical pollution practices by Mittal Steel and not only the relevant water related pollution. The full EIA process was followed and Mittal Steel received a

positive Record of Decision (RoD) from GDACE in February 2004 (ref GAUT 002/02-03/222).

### 5.8.3.2 Upgrade of the CETP Project

The CETP is a plant upstream of the TETP that treats approximately 420m<sup>3</sup>/h of Cold Mills' rolling effluents and then sends this treated effluent to the TETP for further treatment. The CETP will continue to receive all of its existing effluent inputs. The CETP will process all these inputs using the same reaction chemistry, but with new and enlarged reactors and as three separate streams.

At that time the CETP treated all its effluents in one single stream through a single reactor. In the reactor, lime is added to a pH of approximately 10 after which the mixture flows to a set of five clarifiers. The treated water overflowing the clarifiers flow to the TETP for further treatment, and the underflow, containing mostly iron, chromium and stannous hydroxides and calcium fluoride is pumped to the sludge dams.

In the previous set-up some components in the oily effluents inhibit chemical reactions that are required to properly clean the inorganic effluents. The reactor had a too short residence time (reactor capacity is too small) for the completion of some reactions. These two issues were addressed in the upgraded plant. With the upgraded plant it is now possible to eliminate the use of sludge dams, as the sludge will be dewatered with 2 x 50% filter presses.

In the upgraded CETP the effluents are treated as indicated in Figure 5.4 in three separate streams, namely:

- ✚ acid neutralisation (30 m<sup>3</sup>/h),
- ✚ oily effluent treatment (140 m<sup>3</sup>/h), and
- ✚ inorganic effluent treatment, used for stannous, fluoride and chromium containing effluents (250 m<sup>3</sup>/h).

These new reactors have longer residence times than the previous reactor to ensure that the soluble fluoride and magnesium levels in the reactor product are significantly lower than previously. The lower magnesium hardness in this effluent also lessens the need to do magnesium softening at the new MTP. Six new reactors in total were constructed: two sets of three sequential reactors, one set for oily effluent treatment and one for inorganic effluent treatment.

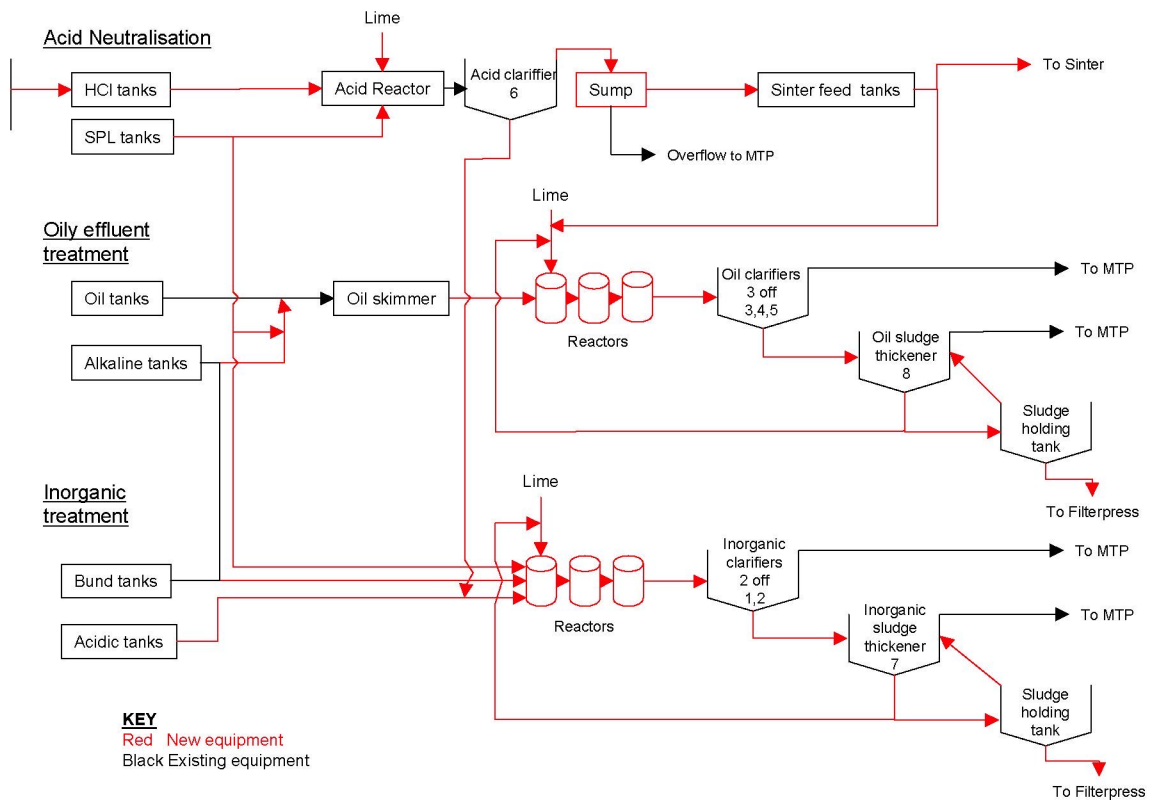

**Figure 5.4: CETP Process Flow**

(Wilson, 2003:5 [as derived from Paxton], 2002b)

The five existing clarifiers are now used separately: two for inorganic effluent clarification and three for the oily effluent circuit. In this way the inorganic and organic effluents are kept separate and the sludge will also be separate, allowing sludge recycling to the inlet of the two systems respectively.

Two of the old redundant clarifiers were modified to be used as thickeners for the two separate sludges. A portion of the thickened sludge is now recycled while the rest is fed to the new filter presses for dewatering and final disposal. The aim of the sludge recycling is to recover some of the excess lime and also to enhance crystal growth.

The upgraded CETP is designed to produce a maximum of 2500 kg/h of sludge (assuming 50% moisture content). This sludge is stored temporarily in a 120m<sup>3</sup> concrete bunker. The sludge is regularly loaded onto a truck by a loading shovel and transported to an appropriate dumping site for final disposal.

Scope of work for upgrading the CETP mainly consisted of:

- three inorganic reactors and three organic reactors complete with mixers, constructed from concrete, each with a residence time of 20 minutes.

- ✚ two 1250 kg/h filter presses, complete with filter press building and sludge bunker.
- ✚ modifications to two old clarifiers to be used as thickeners.
- ✚ associated pumps and pipe work.
- ✚ process control and instrumentation equipment.
- ✚ electrical power systems, MCCs, local control stations, plant cabling and cable racking.

### 5.8.3.3 The MTP Project

The Vanderbijlpark plant of Mittal Steel used approximately 1 460 m<sup>3</sup>/h of freshwater from the Vaal River and 1 250m<sup>3</sup>/h from the Vaal Dam and its dry weather discharge into the Rietspruit before the implementation of the ZED measures was about 1 300 m<sup>3</sup>/h.

The TETP at that time treated all the effluent before it was discharged. This effluent included both process water and rainwater as indicated in Figure 5.5.

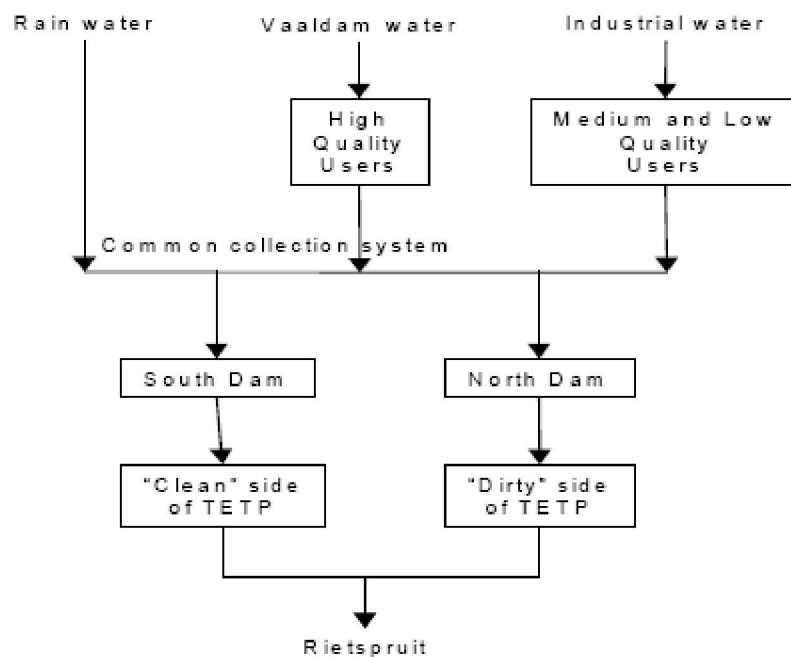

**Figure 5.5: Previous Effluent Treatment System**

(Wilson, 2003:6 [as derived from Paxton], 2002b)

In the previous configuration rainwater and process effluents were collected in a common collection system. Process effluents consisted primarily of treated effluent from the CETP, cooling tower blow down water, cooling tower sand filter backwash water, quench water

and boiler blow down water.

All these effluents were buffered in the South Dam and North Dam before they were treated in the TETP. From the two buffer dams the effluent gravitated through grit/oil chambers where grit and oil were removed. The water then flowed through flocculation chambers where a flocculent was dosed and from there to six sedimentation tanks where the water was clarified. The water was then pumped through two banks of nine sand filters before the water flowed out of the Works to the Rietspruit. Sludge that was removed in the process was pumped in a sludge dam.

The aim of this part of the MTP project was to achieve two main objectives, namely to separate the rainwater and process water collection systems and to modify the current TETP to enable physical as well as chemical treatment.

The TETP was originally designed and built with the following treatment facilities: Two buffer dams, oil/grit removal facilities, flocculation chambers, sedimentation tanks and sand filters. The water from the two buffer dams was treated as two parallel streams in the TETP. The two streams were known as the “Clean” and “Dirty” water systems. The streams were totally separate, except for a common filter backwash and desludging system.

As a result of it being possible to use gravity drainage for all the process effluents to the TETP it was decided to upgrade the existing TETP and to use the adjacent area for the salt removal part of the MTP. A part of the TETP (the so-called “Clean” half) will stay in operation as previously, for the treatment of rainwater.

As a result of the better performance of the upgraded CETP, the optimisation of water recycling and cascading systems and the separation of rainwater and process water, the MTP now have three separate water streams to treat:

The first stream is treated in the storm water treatment system (previously the “Clean” side of TETP). This system remained mainly unchanged, except for some upgrading and modifications on the control and filter backwash systems.

The second stream is now treated in the process water treatment system (previously the “Dirty” side of TETP) where the aim is to soften the water. This softening is aimed at removing the hardness compounds (i.e. calcium and magnesium). This renders the water suitable for recycling to the cooling tower circuits. Other elements such as chlorides, sodium and potassium are concentrated and controlled by purging this recycling system to the next system of the MTP. The process water treatment system is designed to treat 1 300 m<sup>3</sup>/h on average with a maximum hydraulic capacity of 2 000 m<sup>3</sup>/h.

The scope of work for the process water system included:

- ✚ transfer pumps from the buffer dams to process water system;
- ✚ softening reactors (4 x 100 m<sup>3</sup> complete with stirrers);
- ✚ soft water return pumps to recycle the softened water back to the Works,
- ✚ chemical storage and dosing equipment;
- ✚ filter presses (2 x 60% filter presses with a total capacity of 1 800 kg/h @ 50% moisture content). the filter presses are common for sludge from both the process water system and salt removal system;
- ✚ associated pumps and pipe work;
- ✚ process control and instrumentation equipment; and
- ✚ electrical power systems, MCCs, local control stations, plant cabling and cable racking.

The third stream is treated in the salt removal system. This system receives purged water from the process water system and its aim is to remove all the dissolved salts (Cl, Na, K, etc.) that cannot be removed by the process water system.

Process units required for the salt removal system include:

- ✚ lined buffer dams;
- ✚ softening reactors (3 x 100 m<sup>3</sup> reactors in series complete with stirrers);
- ✚ chemical softening (2 x 50 % clarifiers with 0.33 m/h rise rate);
- ✚ multimedia filters, capable of handling a flow of 220 m<sup>3</sup>/h;
- ✚ granulated activated carbon filters (GAC);
- ✚ a two stage Reverse Osmosis (RO), consisting of cellulose acetate spiral wound membranes;
- ✚ evaporator/crystalliser to treat the brine from the RO plant;
- ✚ common sludge thickener for sludge from the process water system and salt removal system;
- ✚ chemical storage and dosing equipment, storage tanks are shared with process water system;
- ✚ associated pumps and pipe work;
- ✚ process control and instrumentation equipment;
- ✚ electrical power systems, MCCs, local control stations, plant cabling and cable racking; and
- ✚ the capacity of this system is 220 m<sup>3</sup>/h. Figure 5.6 illustrates the configuration of the MTP concept.



other unwanted components, such as manganese, in addition to the normal calcium and magnesium. The main portion of the blow down and backwash waters from these low quality users is distributed back to the process water dam (as described in d) below).

- c) Direct some of the blow down and the backwash waters from the low quality user circuits, as mentioned in b), to secondary users (very low quality users) where further increases in the quantity of dissolved salts and the consequent potential for scale formation and corrosion will not cause significant operational problems. These very low quality users include coke quenching and the various slag quenching and granulation functions. The quantity (not quality) of waters that is directed to these very low quality users has to be controlled, not on the basis of how much water these very low quality users normally consume, but on the basis of blowing down enough of the more concentrated effluents from the low quality users so as to purge enough dissolved salts and thereby preventing the build-up of these salts to levels where corrosion or other unacceptable problems could occur within low quality user circuits.
- d) Direct the remainder of the blow down and backwash waters from the low quality user circuits, as described in b), back to the process water dam.
- e) Purge the very low quality users' water circuits of their excess volume to the evaporator feed dam and add contaminated ground water. Then feed this water into the salt removal system in order to remove all the various dissolved salts, which have accumulated from the source waters, from the very low quality users and from the groundwater. If necessary, purge more volume than the above excess volumes, if this is required in order to keep the dissolved salts content within acceptable limits.
- f) Feed the concentrated brine product from the evaporators and RO units within the salt removal system to a new crystalliser plant.
- g) Feed the condensate from the evaporators and the crystalliser, together with any permeate from RO units through an organics removal stage to a selected location within the industrial water distribution system so that it can be used as feed water for the high pressure boilers' demineralisation plant, where its higher purity with respect to industrial water will be best exploited.

The process flow of the three systems of the MTP is illustrated in Figure 5.7.

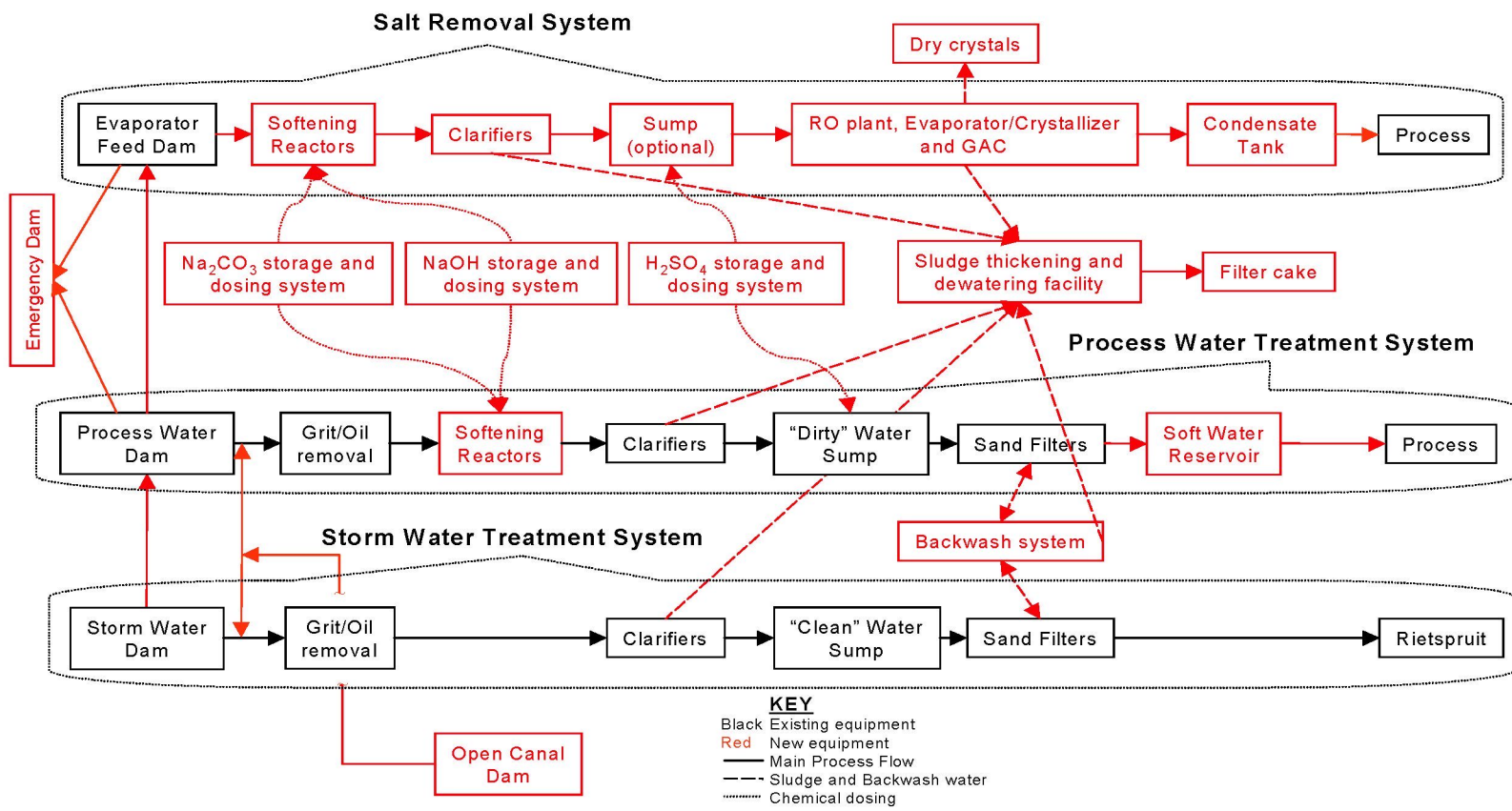

Figure 5.7 : MTP Process flow

(Wilson, 2003:8 [as derived from Paxton], 2002b)

#### **5.8.3.4 Separation of Storm Water and Effluent and Redistribution of Effluents**

This project covered the supply, manufacture, delivery, off-loading, erection, painting, testing, commissioning and testing of:

- ✚ modifications and additions to existing Works infrastructure to enable the separation of rainwater and process effluent water systems.
- ✚ modifications and additions to existing Works infrastructure to enable redistribution of the treated waters back into the Works systems for reuse. The redistribution part of the project entailed a number of pipe modifications to the existing industrial water distribution network to enable the recycling of treated water back to the relevant processes.

The process water is now collected in new collection pipes that route this water to the process water dam. This dam is lined according to Hazardous Lagoon Standards. From here the water is softened in the process water system as described above. This step is required to reduce the water volume that needs to be softened and also because it is a licence requirement.

Storm water is collected by the existing storm water collection canals and gravitates to the storm water dam. From this dam the water gravitates to the “Clean” side of the MTP. Water from the southern side of the works that cannot gravitate to the storm water dam is collected in the new open canal dam. From here it is also pumped to the “Clean” side of the MTP.

Storm water is then treated with exactly the same equipment and in exactly the same process as previously. The only difference is that only one half of the current TETP is used, because there is no longer a volume of process water mixed with the storm water. The storm water is treated to comply with the standards as specified in the water license and only then discharged into the Rietspruit.

#### **5.8.3.5 Emergency Dam Project**

The emergency dam consists of two separate halves: one half for organically contaminated water and the other half for inorganically contaminated water, each with a capacity of 100ML.

Previously all the treated effluents were discharged via the Rietspruit and therefore a big storage dam was not required. Due to the fact that the MTP would require regular

maintenance with the major maintenance shutdowns longer than the buffer capacity available in the buffer dams at the MTP, ZED compliance was at risk. These shutdowns could for instance include a yearly cleaning of heat exchangers that could typically last for up to five days. During these maintenance periods as well as any other emergency, effluent will be stored in the emergency dam for treatment later on.

## **5.9 Conclusion**

The Mittal Steel plant in Vanderbijlpark reduced the intake of water and eliminated the discharge of effluent. The lessons learned while becoming a ZED facility would benefit the industry as wastewater minimisation is now such an important environmental issue to South African industry. From his experience in this project the researcher recognised the opportunity to explore the BMPs to attain ZED in South African industry and to create a framework of practices for others who need to implement a similar project, to execute it more effectively. Chapter Six will validate the BMP framework developed in Chapter Four against the practices applied by Mittal Steel.

## CHAPTER 6 VALIDATION

### 6.1 Introduction

There are various arguments against and criticism of the validation of a case study research because of potential investigator subjectivity. Yin (1984, 1993, 1994) proposed remedies to counteract this, including using multiple sources of evidence and establishing a chain of evidence. Yin further maintains that the possibility of "inference" in case studies can be dealt with using pattern-matching and for that reason the representative case studies of Chapter Three in this research were selected to assist in validating the BMP framework against the practices applied by Mittal Steel.

The validation will be done for the three groups of BMPs under the following headings:

- ✚ Governance BMPs.
- ✚ Project Management BMPs.
- ✚ Water Use Efficiency, Preventative and Operational BMPs.

### 6.2 Validation of Governance BMPs

The BMP framework includes various Governance BMPs which will guide industries towards their goal to be admired for their contribution to the environment and the neighbouring society, the well-being of its people and their families. The practices in the framework take cognisance that there are several parties (including shareholders, customers, suppliers, employees and the Government) affected by the operations of South African industries. The BMP framework shows that collective responsibility is essential for attaining ZED in South African industries. The various environmental issues faced by industries today are interrelated and the BMP framework should therefore be considered in a holistic manner.

A comprehensive summary of the legal requirements was included as part of the Mittal Steel Environmental Master Plan to provide an overview of the requirements pertaining to Mittal Steel's Vanderbijlpark plant. The surface water baseline studies also supported the various regulatory processes and legal requirements. The BMP framework includes several Acts and Regulations under section 4.2.3 that should be considered when dealing with the substantial and complicated legal requirements involved and the impact of legislation on the sustainability of South African industries, especially when ZED compliance is a requirement. The practices included in section 4.2.7 demonstrate the important actions required to guarantee the EIA process is managed effectively.

A strategic approach was followed for the development of the Mittal Steel Environmental

Master Plan. This strategic approach complied with the comprehensive environmental strategy framework of South African Legislation and associated guidelines. The ZED concept is qualified and the objectives as stated in the Environmental Master Plan can be regarded as a policy statement and hence provide overall guidance for performance. The Environmental Master Plan and strategy towards ZED was, however, not a transparent plan according to a clearly stated policy on a company/facility wide level. Furthermore, the environmental management areas were not aligned to the basic requirements of performance objectives, i.e. being measurable and achievable. There is also no clear indication of where and when these objectives would apply.

The BMP framework, however, addresses these shortfalls in the Mittal Steel application as part of the environmental responsibility in section 4.2.6. The practices in the BMP framework illustrates as part of the environmental responsibility how Mittal Steel's objective of ZED should have been expanded to develop plant/facility level objectives in terms of water usage and effluent discharge. Interim goals and plant/facility targets in terms of water utilisation and effluent discharge were absent and the management of non-compliance with the overall ZED goal would be difficult to manage in the Mittal Steel case. The BMPs in the framework would contribute management information essential to the success of ZED.

The BMP framework includes practices for interaction with the public as an interested stakeholder as part of the social responsibility (section 4.2.4) and also during the public participation process of the EIA section (section 4.2.7). By applying these practices, negative reports and historic negative judgement (as experienced by Mittal Steel) towards industries might be reduced. Industries should apply the BMPs and fully appreciate the growing demand for accountability, honesty and transparency in fulfilling their environmental and social duties towards all stakeholders of which the neighbouring community forms part. The BMP framework includes the public participation process as part of the EIA application and this should give all stakeholders the opportunity to be part of the decision making process towards realising ZED.

One of the social influences that may affect projects and the success of attaining ZED in South African industries and which is not addressed in the BMP framework are cultural influences. The most recent Mittal Steel corporate social strategy includes this influence. Every project should operate within a context of one or more cultural norms. These cultural norms include the various South African political, demographic, educational, ethical, ethnic, religious, economic, and other areas of practice, belief and attitudes that affect the way people and organisations interact. This is an area that will impact heavily on the ZED status and is a potential for future research to include the diverse South African cultural influences in the practices of the BMP framework.

### 6.3 Validation of Project Management BMPs

The Project Management Body of Knowledge (PMBOK) is a globally recognised standard for the practice of the project management profession throughout the world. Mittal Steel implemented the four core project management functions of scope, quality, time and cost through the four facilitating functions of risk, human resources, procurement and the required communication practices. The Project Management BMPs cover the nine PMBOK subject areas in sufficient depth to understand and apply sound project management principles and practices necessary for the successful planning and accomplishment of the ZED projects. Projects and project management, however, operate in an environment broader than that of the project itself. The Project Management BMP framework includes some of the day-to-day activities that are necessary for project success. A key practice is to assign the correct resources (team members) to a project team and to involve all the necessary stakeholders whose interests may be positively or negatively affected as a result of project execution or successful project completion as indicated in the BMPs included in section 4.3.1. The project management team should use the framework to apply this broader context.

The studies and projects required in attaining ZED compliance are very complex with many water/effluent collection, conveyance and treatment components. The implementation of the Mittal Steel project included various Project Management BMPs from the framework, especially while managing the interdependence between the different projects and the critical path projects to ultimately achieve the ZED goal. The practices included in section 4.3.3 give a high level guide towards project scope and integration of such projects.

It does, however, emerge that a combination of professional judgement and opinions of the various specialists, who participated in the development of the Mittal Steel Environmental Master Plan and ZED strategy, as well as qualitative ranking methodologies were applied to prioritise management measures. Possible changes in site behaviours due to the implementation of the proposed management measures have not been quantified. Performance objectives have also not been identified. A change management system as illustrated in BMPs 80, 81 and 82 would have improved Mittal Steel's management system.

The BMP framework does not address the different project phases, which collectively form the project life cycle. The Mittal Steel case study can be divided into conceptual studies, a pre-feasibility phase and an implementation phase. These phases are required to provide better management control and appropriate links to the ongoing operations of the performing organisation. Projects are unique undertakings and thus involve a degree of uncertainty. Although many project life cycles have similar phase names with similar work products required, few are identical. Most have four or five phases, but some have nine or

more.

The BMP framework fittingly requires in section 4.3.2 that the significant body of source documentation employed in all the phases towards ZED should be referenced and indexed for future use. The implementation of ZED practices will no doubt require further refinement and optimisation over time. Access to the required documentation is also required to ensure other companies learn from earlier mistakes by others and apply the best practices already implemented by others.

#### **6.4 Validation of Water Use Efficiency, Preventative and Operational BMPs**

The first two sections of the BMP framework illustrate the importance of encouraging the development of environmental awareness and the subsequent identification of the sources of pollution. The Mittal Steel case study also highlights the importance of pollution prevention at source and the effort required to achieve success will only be realised if all employees are educated, are familiar with the environmental requirements and form part of the process to secure a ZED status.

Mittal Steel followed the same approach recommended by the BMP framework in terms of identifying the quality of water required by a specific process. The practices used in the Mittal Steel Environmental Master Plan for the process water strategy were primarily focussed on the determination of water quality requirements for the relevant water sources. The BMP framework recommends in section 4.4.3 that The South African Water Quality Guidelines, developed by the DWAF should be used for this purpose. The risks Mittal Steel might be exposed to by not using the South African Water Quality Guidelines are changes in regulatory control and associated modified application of legislation. Possible knowledge virtues, such as the receiving environment characterisation as well as experience of and good relationships with the regulatory authorities might be forfeited by Mittal Steel, but was covered by the application of the practices in the framework of Chapter Four.

The BMPs adequately incorporated the different aspects of practices used for pollution prevention at source, pollution control at source, reduction of water consumption, effluent separation, the recycle and reuse of effluent between different plants, practices for the safe use and storage of chemicals and residues management. The Mittal Steel ZED case study confirmed the importance of including these practises for the successful accomplishment and sustainability of ZED compliance.

The upgrade of the CETP and the new MTP were based on well established engineering

practices. The concepts and processes chosen for the different plants reflect application of known and proven technology and practices. Adequate attention was given to the implementation of the concepts during the design and construction of the different plants. The basis of design in terms of effluent flows and quantities, and of unit treatment process performance should, however, be compiled in a single document for reference purposes. The BMP framework does not, however, include practices to guide industries in choosing the correct concepts and technologies, but reference to the report by the U.S Department of the Interior Bureau of Reclamation (refer to Appendix A for the index) adds this dimension to the framework.

BMP 186 addresses the implementation of run-off and catchment modelling. No specific run-off modelling or catchment modelling were conducted to depict possible changes in impact for the hydrological situation pertaining to Mittal Steel's Vanderbijlpark plant. Cognisance was not taken of changes in site behaviours due to the implementation of mitigating measures, extreme weather conditions or major plant upsets. The absence of these poses a risk, since the unexpected could occur as well as unreasonable or unattainable regulatory requirements which could be imposed over time. The construction of the emergency dam created some buffer capacity in crisis situations. There is not, however, buffer storage capacity between the different plants to cater for potential differences between internal water supply and demand.

The analysis and evaluation of a complex water system such as the Mittal Steel system in Vanderbijlpark would benefit from a user-friendly dynamic (not historical) water system simulation model as addressed in BMP 187. Sufficient information and knowledge have been accumulated to compile and sustain such a model.

## **6.5 Conclusion**

There are frequent similarities in the practices included in the BMP framework outlined in Chapter Four and the application of practices to attain ZED by the Mittal Steel plant in Vanderbijlpark, as summarised in Chapter Five. Although the Mittal Steel case study cannot presume to be representative of all the aspects industries face with the challenges to attain ZED status, the successful attainment of ZED makes it a commendable reference study. In comparison, the practices applied by Mittal Steel represent many of the dimensions outlined in the BMP framework.

It may therefore be confirmed that the predominance of practices included in the ZED BMP framework are consistent with the practices applied by Mittal Steel and will therefore be a significant tool to aid industries in South Africa to attain ZED status.

## CHAPTER 7 CONCLUSION AND RECOMMENDATIONS

### 7.1 Conclusion

A literature review was done to identify current environmental practices and to develop a framework of practices to attain ZED in South African industries. The most frequently encountered reason found in literature for the need to achieve ZED and to implement key practices, is a result of the ever increasing environmental regulatory requirements. The literature findings indicate how the complicated legal requirements and different courses of action to be followed can affect the sustainability of South African industries. The literature findings from the two case studies are considered to be more than just the identification of different technologies to treat effluent since it also takes into account the governance and project management practices to attain ZED in South African industries. The literature also indicated the importance of taking the different principles for effective water use into account when developing BMPs to attain ZED.

A framework of practices was compiled, applying practices from the researcher's own experience, the literature survey and case studies, with the aim to provide information and examples of procedures used by industry to keep pollutants from the effluent entering the neighbouring aquatic environment and to remain compliant with regulatory requirements. The BMP framework embodies practices for one integrated strategy within three dimensions. The three dimensions of the BMP framework were selected to differentiate between BMPs for management (Governance BMPs), for the project management team responsible for ZED projects (Project Management BMPs) and for the implementation of preventative and operational measures to obtain and sustain ZED compliance for South African industries. The BMP framework will enable industry to develop their own BMP Manual which should be specific to their operational and environmental requirements. The implementation of these BMPs should be tailored and used accordingly to demonstrate compliance to the ZED requirements in the South African industry.

The BMP framework was validated against the practices applied by Mittal Steel. As part of the commitment of Mittal Steel Vanderbijlpark to the creation of a safe and healthy environment and its endeavours to conduct its business in an environmentally sound and acceptable manner, they made a commitment to the relevant authorities to be ZED compliant by the end of December 2005. The Mittal Steel plant in Vanderbijlpark implemented various projects, reduced the intake of water and eliminated the discharge of effluent and by doing this successfully realised their ZED status as promised. The validation of the BMP framework against the Mittal Steel case study concludes that there is a parallel in the practices included in the BMP framework and the application of practices to attain

ZED by the Mittal Steel plant in Vanderbijlpark.

**It may therefore be concluded that the ZED BMP framework will provide the required methodology for industries in South Africa to attain and sustain ZED status.**

## **7.2 Recommendations**

South African industries, faced with the challenges associated with implementing measures to reduce or eliminate the discharge of effluents and with the ultimate requirement of becoming ZED compliant, must use these BMPs to meet the ZED statutory requirements. The framework now provides all interested stakeholders with practices to meet the ZED statutory requirements. The framework can be tailored to be universal and relevant as a BMP framework to attain ZED in the South African industries. It is recommended that each industry uses these practises as a tool to develop and implement a set of site specific practices required for an effluent release strategy.

## **7.3 Recommendations for further Research**

The BMP framework does not address the different project phases, which collectively form the project life cycle. Herein lies the need for potential and additional studies to include the different project phase deliverables in the BMP framework. A deliverable is a tangible, verifiable work result such as a concept study, a feasibility study, basic engineering, a detail design, or the execution of projects. The deliverables, and hence the phases, are part of a generally sequential logic designed to ensure proper definition of the project. The project life cycle for ZED projects will determine which transitional actions at the end of the phases, and in the end the project, are included and which are not. In this manner, the project life cycle definition can be used to link the project to the ongoing operations and sustainability of ZED compliance by South African industries.

## BIBLIOGRAPHY

ACTS see SOUTH AFRICA

AGENDA 21. 1997. Economic Aspects of Sustainable Development in South Africa, based on South Africa's submission to the 5th Session of the United Nations Commission on Sustainable Development. Available from:

<http://www.un.org/esa/agenda21/natlinfo/countr/safrica/eco.htm> [Date of access: 9 August 2008].

ANONYMOUS. 2008. Environmental Complaints reporting. *Vereeniging Ster*. 8 - 12 September 2008, Page 26.

AUCAMP, P.J. 2006. Environmental Impact Assessments. Ptersa Environmental Management Consultants.

BABUNA, F.G., KABDASLI, I., SOZEN, S., and ORHON, D. 2006. Effluent Management for a Metal Finishing Industry Aiming Zero Discharge Conditions. *Journal of Environmental Science and Health*. Part A, 41:1793-1806, ISSN: 1093-4529 (Print); 1532-4117 (Online) C\_ Taylor & Francis Group, LLC.

BARNARD, D. 1999. Environmental Law for all: A Practical guide for the business community, the planning professions, environmentalists and lawyers. Pretoria: Impact Books CC.

BOARDMAN, A.E., GREENBERG, D.H., VINING, A.R. AND WEIMER, D.L. 2000. Cost-Benefit Analysis: Concepts and Practice (2nd ed). Upper Saddle River, New Jersey, Prentice Hall.

BROUCKAERT, C.J., and BUCKLEY, C.A. 2003. The Application of Pinch Technology to the Rational Management of Water and Wastewater in an Industrial Complex. Pollution Research Group, University of Natal, Durban.

COCK, J. and MUNNIK, V. 2006. Throwing Stones at a Giant: an account of the Steel valley struggle against pollution from the Vanderbijlpark Steel Works. Report for the Centre for Civil Society, University of Kwazulu Natal.

CONLEY, A.H. 1992. South Africa's Water Management: Burning Questions and Key Trends. DWAF. Department of Water Affairs and Forestry.

CONSTITUTION see SOUTH AFRICA. 1996.

DAVEY, L. 1991. The application of case study evaluations. *Practical Assessment, Research & Evaluation*, 2(9). Available from: <http://PAREonline.net/getvn.asp?v=2&n=9> [Date of Access: May 3, 2008]

DENNIS, L. 1964. *The idea of law*. Penguin Books.

DWAF (Department of Water Affairs and Forestry), South Africa. 1991. *Water Quality Management Policies and Strategies in the RSA*. DWAF. Pretoria: Government Printer.

DWAF (Department of Water Affairs and Forestry), South Africa. 1996. *South African Water Quality Guidelines (1<sup>st</sup> edition)*. CSIR Environmental Services, ISBN 0-7988-5338-7 (Set), Pretoria: Government Printer.

DWAF (Department of Water Affairs and Forestry), South Africa. 2004. *Upper Vaal Water Management Area: Internal Strategic Perspective*. Prepared by PDNA, WRP Consulting Engineers (Pty) Ltd, WMB and Kwezi-V3 on behalf of the Directorate: National Water Resource Planning. DWAF Report No P WMA 08/000/00/0304.

GARSON, G.D. 2008. *Case Studies*. NCSU Master's and Ph.D Programs in Public Administration, North Carolina State University.

GOOCH, G. D. AND HUIITEMA, D. 2004. Improving governance through deliberative democracy: Initiating informed public participation in water governance policy processes. Paper presented at the Stockholm Water Symposium, 18 August 2004.

GUTRICH J., DONOVAN D., FINUCANE M., FOCHT W., HITZHUSEN F., MANOPIMOKE S., MCCAULEY D., NORTON B., SABATIER P., SALZMAN J., SASMITAWIDJAJA V. 2005. Science in the public process of ecosystem management: lessons from Hawaii, Southeast Asia, Africa and the US Mainland. *Journal of Environmental Management*. Vol. 76, No.3, pp.197-209.

MIRRILEES, R.I., FORSTER, S.F., WILLIAMS, C.J. 1994. *Water Research Commission Report 415/1/94*. Institute of Natural Resources, University of Natal.

MITTAL STEEL. 2005. *Vanderbijlpark Steel Intranet*. Available from: <http://vdb-www01/factory/dashboard.asp> [Date of access: 29 April 2005].

MITTAL STEEL. 2008. *Arcelor Mittal South Africa Limited*. Available from: [http://www.iscor.com//UploadedFiles/ContentFiles/manual\\_of\\_mittal\\_staal\\_and\\_subsidiaries](http://www.iscor.com//UploadedFiles/ContentFiles/manual_of_mittal_staal_and_subsidiaries). [Date of access: 25 October 2008]

OFT (Ockie Fourie Toxicologists). 2002. Iscor Vanderbijlpark Steel Environmental Master Plan Summary report - Draft for discussion. Series 1, Document IVS/MP/001.

OMB (Office of Management and Budget). 1992. Guidelines and Discount Rates for Benefit-Cost Analysis of Federal Programs. (Circular No. A-94 [Revised]). Washington DC: US Government.

PAXTON, R AND ASSOCIATES. 2002a. Iscor Vanderbijlpark Steel process Waters Master Plan Report: Part 1 of 2. RPA Report no: LA1075. Beacon Street. Lichfield: R. Paxton and Associates limited.

PAXTON, R AND ASSOCIATES. 2002b. Iscor Vanderbijlpark Steel process Waters Master Plan Report: Part 2 of 2. RPA Report no: LA1075. Beacon Street. Lichfield: R. Paxton and Associates limited.

SASOL. 2003. Sasol Technology (Pty) Ltd. Business Development and Implementation Model Rev 4 (as amended). Sasolburg. Sasol Technology.

SHIKLOMANOV, I.A. 2000. World Water Resources and their Use. Paris: UNESCO and the State Hydrological Institute, St Petersburg.

SOUTH AFRICA. 1989. *Environmental Conservation Act 73 of 1989*. Pretoria: Government Printer.

SOUTH AFRICA. 1996a. *Constitution of the Republic of South Africa Act 108 of 1996 as adopted by the Constitutional Assembly on 8 May 1996 and as amended on 11 October 1996*. (B34B-96.) (ISBN:0-260-20716-7.)

SOUTH AFRICA. 1996b. *The Bill of Rights of the Constitution of the Republic of South Africa (1996)*. Government Gazette. (No. 17678).

SOUTH AFRICA. 1997. *Water Services Act 108 of 1997*. Pretoria: Government Printer.

SOUTH AFRICA. 1998a. *National Environmental Management Act 107 of 1998*. Pretoria: Government Printer.

SOUTH AFRICA. 1998b. *National Water Act 36 of 1998*. Pretoria: Government Printer.

TATE, D.M. 2000. *Principles of water use efficiency*. Available from:

<http://www.cepis.ops-oms.org/muwww/fulltext/repind48/principles/principles.html> [Date of access: 15 January 2008].

TCHOUKANOVA, N., GONZALEZ, M., POIRIER, S. 2007. Best Management Practices: Marine Products Processing. Translated from French by Manon Losier and Sylvain Poirier. Prepared according to contract F4760-030015 for Fisheries and Oceans Canada - Gulf Region, by the Fisheries and Marine Products Division of the Coastal Zones Research Institute Inc., Shippagan, New Brunswick, Canada.

TROPP, H. 2005. Building New Capacities for Improved Water Governance. Paper presented at the International Symposium on Ecosystem Governance, 2005, South Africa, organised by CSIR (Council for Scientific and Industrial Research).

U.S DEPARTMENT see U.S DEPARTMENT OF THE INTERIOR BUREAU OF RECLAMATION

U.S DEPARTMENT OF THE INTERIOR BUREAU OF RECLAMATION. 2008. Desalination and Water Purification Research and Development Program Report No. 149 - Evaluation and Selection of Available Processes for a Zero-Liquid Discharge System for the Perris, California, Ground Water Basin. Prepared for Reclamation under Agreement No. 05-FC-81-1153 Task F by Eastern Municipal Water District Carollo Engineers. Denver, Colorado.

UN (United Nations). 2002. Industry Sector Report for the United Nations World Summit on Sustainable Development: The Steel Industry. International Iron and Steel Institute, Brussels, Belgium.

UNESCO (United Nations Educational, Scientific and Cultural Organisation). 2006. Water, a Shared Responsibility: The United Nations World Water Development Report 2. 150 Broadway, Suite 812, New York, UNESCO and Berghahn Books.

WILSON, C.G.F., 2003. Background information for the Main Treatment Plant project. Unpublished raw data.

YIN, R. 1984. Case study research: Design and methods. (1st ed.). Beverly Hills, CA: Sage Publishing.

YIN, R. 1993. Applications of case study research. Beverly Hills, CA: Sage Publishing.

YIN, R. 1994. Case study research: Design and methods. (2nd ed.). Beverly Hills, CA: Sage Publishing

## APPENDICES

### Appendix A: Table of Contents of an Example for the Evaluation and Selection of Available Processes for a ZED System

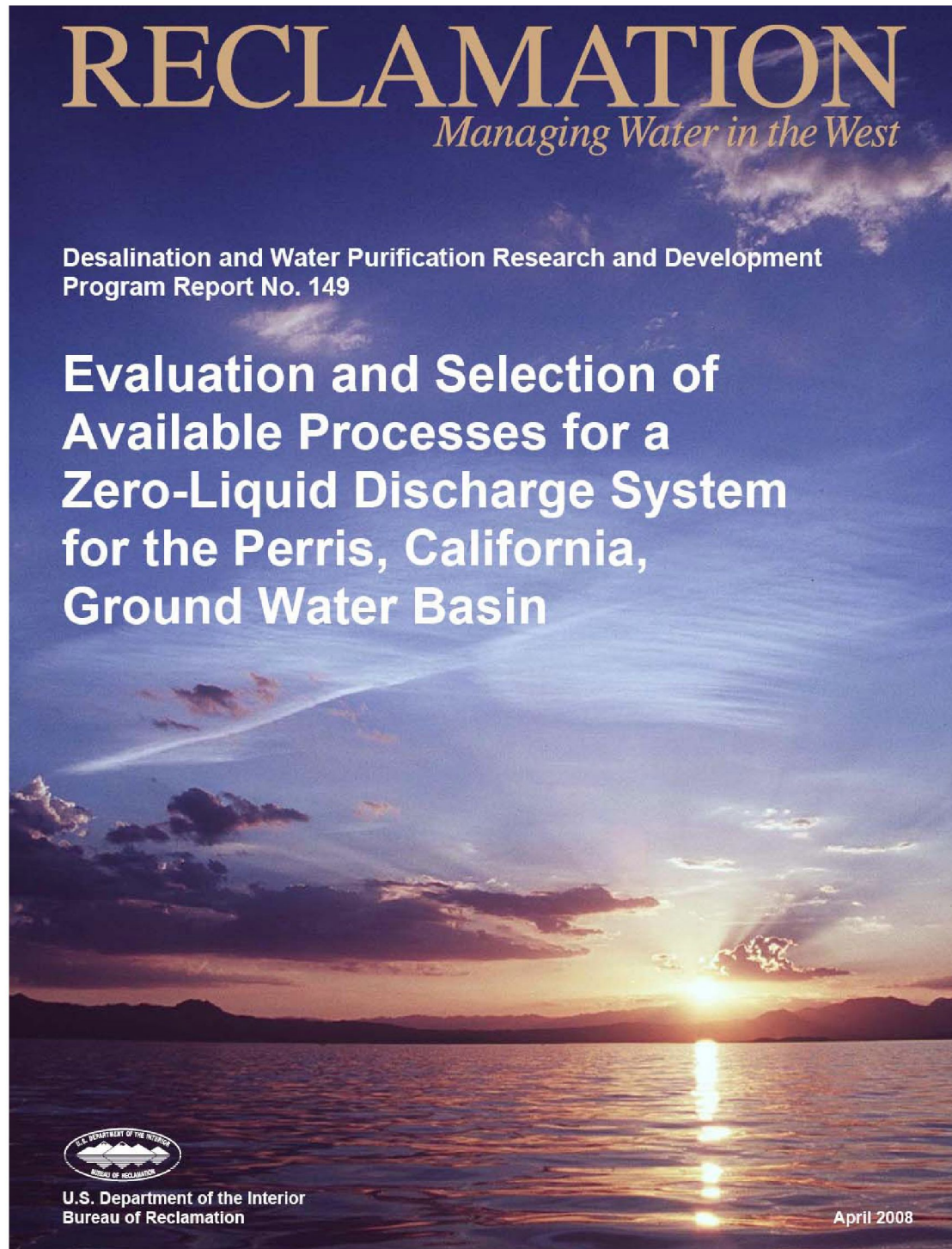

REPORT DOCUMENTATION PAGE			Form Approved OMB No. 0704-0188		
Public reporting burden for this collection of information is estimated to average 1 hour per response, including the time for reviewing instructions, searching existing data sources, gathering and maintaining the data needed, and completing and reviewing this collection of information. Send comments regarding this burden estimate or any other aspect of this collection of information, including suggestions for reducing this burden to Department of Defense, Washington Headquarters Services, Directorate for Information Operations and Reports (0704-0188), 1215 Jefferson Davis Highway, Suite 1204, Arlington, VA 22202-4302. Respondents should be aware that notwithstanding any other provision of law, no person shall be subject to any penalty for failing to comply with a collection of information if it does not display a currently valid OMB control number. PLEASE DO NOT RETURN YOUR FORM TO THE ABOVE ADDRESS.					
1. REPORT DATE (DD-MM-YYYY) April 2008]		2. REPORT TYPE Final	3. DATES COVERED (From - To) October 2005–September 2007		
4. TITLE AND SUBTITLE Evaluation and Selection of Available Processes for a Zero-Liquid Discharge System for the Perris, California, Ground Water Basin			5a. CONTRACT NUMBER Agreement No. 05-FC-81-1153		
			5b. GRANT NUMBER		
			5c. PROGRAM ELEMENT NUMBER		
6. AUTHOR(S) Graham Juby, Ph.D., P.E., Carollo Engineers Adam Zacheis, Ph.D., P.E., Carollo Engineers Wimmie Shih, Ph.D., Carollo Engineers Parameshwaran Ravishanker, P.E., Eastern Municipal Water District (EMWD) Behrooz Mortazavi, Ph.D., P.E., EMWD Michael D. Nusser, EMWD			5d. PROJECT NUMBER		
			5e. TASK NUMBER Task F		
			5f. WORK UNIT NUMBER		
7. PERFORMING ORGANIZATION NAME(S) AND ADDRESS(ES) Eastern Municipal Water District PO Box 8300, Perris CA 92572-8300  Carollo Engineers 10540 Talbert Ave., Suite 200 East, Fountain Valley CA 92708			8. PERFORMING ORGANIZATION REPORT NUMBER		
9. SPONSORING / MONITORING AGENCY NAME(S) AND ADDRESS(ES) U.S. Department of the Interior Bureau of Reclamation Denver Federal Center PO Box 25007 Denver CO 80225-0007			10. SPONSOR/MONITOR'S ACRONYM(S) Reclamation		
			11. SPONSOR/MONITOR'S REPORT NUMBER(S) DWPR No. 149		
12. DISTRIBUTION / AVAILABILITY STATEMENT Available from the National Technical Information Service Operations Division, 5285 Port Royal Road, Springfield VA 22161					
13. SUPPLEMENTARY NOTES Report can be downloaded from Reclamation Web site: <a href="http://www.usbr.gov/pmts/water/publications/reports.html">www.usbr.gov/pmts/water/publications/reports.html</a>					
14. ABSTRACT (Maximum 200 words) Eastern Municipal Water District faces a serious disposal issue for brine produced by their existing and planned primary ground water desalination facilities. The cost of brine disposal, especially for an inland agency, is very expensive and is expected to dramatically increase. As a result, a wide range of existing and emerging water treatment technologies were evaluated for the design of a zero-liquid discharge system. Alternative processes were tested; at pilot-scale, secondary reverse osmosis and electro dialysis reversal; at bench-scale, forward osmosis, membrane distillation, and seeded reverse osmosis; and by desktop modeling, brine concentrators, crystallizers, evaporation ponds, and SAL-PROC™. A cost analysis model based on individual treatment modules was developed for each process alternative with 14 process trains evaluated. Total annual costs ranged from \$5,396,278 to \$8,326,201. These figures represent a sum of the amortized capital annual costs plus operation and maintenance costs, and do not consider the revenue generated from recovered water.					
15. SUBJECT TERMS zero-liquid discharge, ZLD, concentrate, management, desalination, brine					
16. SECURITY CLASSIFICATION OF:			17. LIMITATION OF ABSTRACT SAR	18. NUMBER OF PAGES 40	19a. NAME OF RESPONSIBLE PERSON Scott Irvine
a. REPORT UL	b. ABSTRACT UL	c. THIS PAGE UL			19b. TELEPHONE NUMBER (include area code) 303-445-2253

Standard Form 298 (Rev. 8/98)  
Prescribed by ANSI Std. Z39-18

Desalination and Water Purification Research  
and Development Program Report No. 149

# Evaluation and Selection of Available Processes for a Zero-Liquid Discharge System for the Perris, California, Ground Water Basin

Prepared for Reclamation Under Agreement No. 05-FC-81-1153 Task F

*by*

**Eastern Municipal Water District  
Carollo Engineers**



**U.S. Department of the Interior  
Bureau of Reclamation  
Technical Service Center  
Water and Environmental Services Division  
Water Treatment Engineering Research Team  
Denver, Colorado**

April 2008

# Table of Contents

	<i>Page</i>
Acronyms.....	xi
1. Executive Summary.....	1
1.1 Overview and Study Objectives.....	1
2. Background.....	3
2.1 General Introduction.....	3
2.2 Justification for Research.....	3
2.2.1 Recovery Limitations.....	4
2.2.2 Concentrate Disposal.....	4
2.2.3 Economic Value.....	4
2.3 Project Goals and Objectives.....	6
2.4 Description of Unit Processes for Brine Minimization.....	7
2.4.1 Chemical Softening and Secondary Desalting.....	7
2.4.2 Reverse Osmosis.....	8
2.4.3 Electrodialysis Reversal.....	9
2.4.4 SPARRO (Seeded RO).....	10
2.4.5 Membrane Distillation.....	11
2.4.6 Forward Osmosis.....	12
2.4.7 Residual Recovery (SAL-PROC).....	14
2.4.8 Brine Concentrators.....	15
2.4.9 Crystallizers.....	16
2.4.10 Evaporation Ponds.....	17
2.5 Subcontractors.....	18
3. Technical Approach.....	19
3.1 Project Implementation Plan.....	19
3.1.1 Introduction.....	19
3.2 Pilot Studies.....	20
3.2.1 Chemical Softening and Secondary Desalting.....	20
3.2.2 Reverse Osmosis.....	22
3.2.3 Electrodialysis Reversal.....	22
3.2.4 SPARRO (Seeded RO).....	23
3.3 Bench-Scale Studies.....	25
3.3.1 Membrane Distillation.....	25
3.3.2 Forward Osmosis.....	26
3.4 Desktop Modeling.....	28
3.4.1 Residual Recovery (SAL-PROC).....	28
3.4.2 Brine Concentration and Crystallizer.....	28
3.4.3 Evaporation Ponds.....	29
3.5 Development of Cost Estimates.....	29
3.5.1 Cost-Curve Assumptions.....	29
4. Results and Discussion.....	31
4.1 Primary Brine Water Quality.....	31
4.2 Pilot Studies.....	32

## Table of Contents (continued)

	<i>Page</i>
4.2.1 Chemical Softening and Secondary Desalting.....	32
4.2.2 Reverse Osmosis.....	33
4.2.3 Electrodialysis Reversal.....	37
4.2.4 SPARRO (Seeded RO).....	38
4.3 Bench-Scale Studies.....	44
4.3.1 Membrane Distillation.....	44
4.3.2 Forward Osmosis.....	47
4.4 Desktop Modeling.....	49
4.4.1 Residual Recovery (SAL-PROC™).....	49
4.4.2 Brine Concentration.....	52
4.4.3 Crystallizer.....	53
4.4.4 Evaporation Ponds.....	53
4.5 Process Combination Alternatives.....	54
4.5.1 Alternative 1: Primary RO/Chemical Softening/ Secondary RO/Brine Concentrator/ SARI Discharge.....	54
4.5.2 Alternative 2: Primary RO/Chemical Softening/ Secondary RO/Brine Concentrator/Crystallizer/ Solids Disposal.....	57
4.5.3 Alternative 3: Primary RO/Chemical Softening/ Secondary RO/Brine Concentrator/Evaporation Pond/Solids Disposal.....	57
4.5.4 Alternative 4: Primary RO/Chemical Softening/ EDR/Brine Concentrator/SARI Discharge.....	57
4.5.5 Alternative 5: Primary RO/Chemical Softening/ EDR/Brine Concentrator/Crystallizer/ Solids Disposal.....	58
4.5.6 Alternative 6: Primary RO/Chemical Softening/ EDR/Brine Concentrator/Evaporation Pond/ Solids Disposal.....	58
4.5.7 Alternative 7: Primary RO/Forward Osmosis/ Brine Concentrator/SARI Discharge.....	58
4.5.8 Alternative 8: Primary RO/Forward Osmosis/ Brine Concentrator/Crystallizer/Solids Disposal.....	59
4.5.9 Alternative 9: Primary RO/Forward Osmosis/ Brine Concentrator/Evaporation Pond.....	59
4.5.10 Alternative 10: Primary RO/LOW TDS SAL-PROC #1/Solids Disposal.....	59
4.5.11 Alternative 11: Primary RO/Chemical Softening/ Secondary RO/Seeded RO/SAL-PROC#2/ Solids Disposal/SARI Discharge.....	60

## Table of Contents (continued)

	<i>Page</i>
4.5.12 Alternative 12: Primary RO/Chemical Softening/ Secondary RO/Seeded RO/Brine Concentrator/ SARI Disposal .....	62
4.5.13 Alternative 13: Primary RO/Chemical Softening/ Secondary RO/Seeded RO/Brine Concentrator/ Crystallizer/Solids Disposal.....	63
4.5.14 Alternative 14: Primary RO/Chemical Softening/ Secondary RO/Seeded RO/Brine Concentrator/ Evaporation Pond/Solids Disposal.....	63
4.5.15 Base Case A: Primary RO/SARI Disposal .....	63
4.5.16 Base Case B: Primary RO/Softening/Secondary RO/SARI Disposal.....	64
4.6 Cost Summary.....	64
4.7 Conclusions.....	67
Appendix A University of Nevada, Reno Report on VEDCMD and FO .....	71
Appendix B Geo-Processors USA, Inc. Report on SAL-PTOC.....	73
Appendix C HPD – Veolia Water Solutions Report on Brine Concentrator and Crystallizer .....	75
Appendix D Raw Data Files for Seeded RO Pilot Test.....	77
Appendix E Detailed Cost Estimates.....	79

## List of Figures

<i>Figure</i>	<i>Page</i>
2.1 High-pressure membrane schematic .....	8
2.2 Schematic of electrodialysis process .....	10
2.3 Schematic of seeded RO process concept.....	11
2.4 Schematic of membrane distillation process.....	12
2.5 Schematic of FO process .....	13
2.6 Schematic of brine concentrator (graphic courtesy of GE/Ionics).....	15
2.7 Schematic of brine crystallizer (graphic courtesy of GE/Ionics).....	16
3.1 Process flow diagram for softening secondary desalting.....	21
3.2 Site layout of RO skid, Zimpro softening unit, and EDR trailer .....	23
3.3 Seeded RO process testing setup .....	24
3.4 Bench-scale setup for vacuum enhanced direct contact membrane distillation.....	26

## List of Figures (continued)

<i>Figure</i>	<i>Page</i>
3.5 Schematic of forward osmosis testing system .....	27
4.1 Recovery of secondary RO pilot operation.....	34
4.2 Seeded RO net driving and osmotic pressures for Brine B .....	39
4.3 Seeded RO permeate flux and rejection for Brine B .....	40
4.4 Seeded RO specific flux for Brine B .....	41
4.5 Seeded RO recovery and apparent seed concentration for Brine B .....	41
4.6 SEM of gypsum seeds from seeded RO tests .....	42
4.7 EDAX analysis of seed crystals from seeded RO tests.....	43
4.8 Seeded RO feed, permeate, and brine conductivity for Brine B.....	43
4.9 Water flux versus feed concentration for MD of (A) Brine A and (B) Brine B.....	44
4.10 Comparison of Brine A and Brine B MD results at (A) $\Delta T = 20\text{ }^{\circ}\text{C}$ and (B) $40\text{ }^{\circ}\text{C}$ .....	46
4.11 Water flux versus feed concentration for FO of Brine A and Brine B .....	48
4.12 Conceptual process schematic for FO system .....	49
4.13 SAL-PROC modeling for 1-mgd ZLD treatment of Brine A and Brine C .....	50
4.14 Treatment alternatives for Brines A, B, and C.....	55
4.15 Total capital costs for various treatment alternatives .....	68
4.16 Total annual costs for various treatment alternatives .....	69

## List of Tables

<i>Table</i>	<i>Page</i>
2.1 Summary of Water Quality Data: Menifee Water Quality .....	5
4.1 Summary Water Quality Data for Three Brine Types.....	31
4.2 Summary of Selected Water Quality Results from Chemical Softening.....	32
4.3 Summary of Selected Water Quality Results for RO Permeate .....	33
4.4 Summary of Selected Water Quality Results for EDR.....	38
4.5 Summary of Water Quality Data for Seeded RO Process on Brine B .....	38
4.6 Conceptual Cost Estimates and Projected Revenue Base for the Recommended Brine Treatment Systems .....	52
4.7 Conceptual Cost Estimates for Brine Concentration Treatment Systems (0.125 to 1 mgd) for BC only.....	53

**List of Tables (continued)**

<i>Table</i>		<i>Page</i>
4.8	Conceptual Cost Estimates and Projected Revenue Base for the Recommended Brine Treatment Systems (1 mgd to 0.125 mgd) for BC/XLZR System.....	53
4.9	Cost Comparison of Treatment and Disposal Alternatives.....	66

## Appendix B: Water and the Millennium Development Goals

### GOAL 1. ERADICATE EXTREME POVERTY AND HUNGER\*

Water is a factor of production in virtually all enterprise, including agriculture, industry and the services sector. Improved nutrition and food security reduces susceptibility to diseases, including HIV/AIDS, malaria among others. Access to electricity is key to improving quality of life in the modern age. Competition between the various sectors must be balanced by policies that recognize the ability and responsibility of all sectors to address the issues of poverty and hunger.

#### Targets:

- Have, between 1990 and 2015, the proportion of people whose income is less than \$1 a day
- Have, between 1990 and 2015, the proportion of people who suffer from hunger

#### WWDR2 Water-related Indicators:

- Percentage of undernourished people
- Percentage of poor people living in rural areas
- Relative importance of agriculture
- Irrigated land as percentage of cultivated land
- Relative importance of agriculture water withdrawals in water balance
- Extent of land salinized by irrigation
- Importance of groundwater in irrigation
- Dietary Energy Supply (DES)

See Chapter 7: *Water for Food, Agriculture and Rural Livelihoods*

- Trends in industrial water use
- Water use by sector
- Organic pollution emissions by industrial sector
- Industrial water productivity
- Trends in ISO 14001 certification, 1997-2002
- Access to electricity and domestic use
- Electricity generation by fuel, 1971-2001
- Capability for hydropower generation, 2002
- Total primary energy supply by fuel
- Carbon intensity of electricity production, 2002
- Volume of desalinated water produced

See Chapter 8: *Water and Industry* and Chapter 9: *Water and Energy*

### GOAL 2. ACHIEVE UNIVERSAL PRIMARY EDUCATION

Promotion of a healthy school environment is an essential element of ensuring universal access to education, and school enrolment, attendance, retention and performance are improved; teacher placement is improved. In this respect access to adequate drinking water and sanitation is key.

#### Target:

- Ensure that, by 2015, children everywhere, boys and girls alike, will be able to complete a full course of primary schooling

#### WWDR2 Water-related Indicator:

- Knowledge Index

See Chapter 13: *Enhancing Knowledge and Capacity*

### GOAL 3. PROMOTE GENDER EQUALITY AND EMPOWER WOMEN

Educating women and girls will permit them to fulfil their potential as full partners in the development effort.

#### Target:

- Eliminate gender disparity in primary and secondary education, preferably by 2015 and in all levels of education no later than 2015

#### WWDR2 Water-related Indicator:

- Access to information, participation and justice in water decisions

See Chapter 2: *Challenges of Governance*



### GOAL 4. REDUCE CHILD MORTALITY

Improvements in access to safe drinking water and adequate sanitation will help prevent diarrhoea, and lay a foundation for the control of soil-transmitted helminths and schistosomiasis among other pathogens.

#### Target:

- Reduce by two-thirds, between 1990 and 2015, the under-five mortality rate

#### WWDR2 Water-related Indicators:

- Mortality in children < 5 yrs
- Prevalence of underweight children < 5 yrs
- Prevalence of stunting among children < 5 yrs

See Chapter 6: *Protecting and Promoting Human Health*

### GOAL 5. IMPROVE MATERNAL HEALTH

Improved health and nutrition reduce susceptibility to anaemia and other conditions that affect maternal mortality. Sufficient quantities of clean water for washing pre-and-post birth cut down on life-threatening infection.

#### Target:

- Reduce by three-quarters, between 1990 and 2015, the maternal mortality rate

#### WWDR2 Water-related Indicator:

- DALY (Disability Adjusted Life Year)

See Chapter 6: *Protecting and Promoting Human Health*

### GOAL 6. COMBAT HIV, AIDS, MALARIA AND OTHER DISEASES

Improved water supply and sanitation reduces susceptibility to/severity of HIV/AIDS and other major diseases.

#### Targets:

- Have halted by 2015 and begun to reverse the spread of HIV/AIDS
- Have halted by 2015 and begun to reverse the incidence of malaria and other major diseases

#### WWDR2 Water-related Indicator:

- DALY (Disability Adjusted Life Year)

See Chapter 6: *Protecting and Promoting Human Health*

## GOAL 7. ENSURE ENVIRONMENTAL SUSTAINABILITY

Healthy ecosystems are essential for the maintenance of biodiversity and human well-being. We depend upon them for our drinking water, food security and a wide range of environmental goods and services.

### Target:

- Integrate the principles of sustainable development into country policies and programmes and reverse the loss of environmental resources

### WWDR2 Water-related Indicators:

- Water Stress Index
- Groundwater development
- Precipitation annually
- TARWR volume (total annual renewable water resources)
- TARWR per capita
- Surface water (SW) as a % TARWR
- Groundwater (GW) as a % of TARWR
- Overlap % TARWR
- Inflow % TARWR
- Outflow % TARWR
- Total Use as % TARWR

See Chapter 4: *The State of the Resource*

- Fragmentation and flow regulation of rivers
- Dissolved nitrogen (NO<sub>3</sub> + NO<sub>2</sub>)
- Trends in freshwater habitat protection
- Trends in freshwater species
- Biological Oxygen Demand (BOD)

See Chapter 5: *Coastal and Freshwater Ecosystems*

### Targets:

- Halve by 2015 the proportion of people without sustainable access to safe drinking water and basic sanitation
- By 2020, to have achieved a significant improvement in the lives of at least 100 million slum dwellers

### WWDR2 Water-related Indicators:

- Urban Water and Sanitation Governance Index
- Index of Performance of Water Utilities

See Chapter 3: *Water and Human Settlements in an Urbanizing World*

- Access to safe drinking water
- Access to basic sanitation

See Chapter 6: *Protecting and Promoting Human Health*

## GOAL 8. DEVELOP A GLOBAL PARTNERSHIP FOR DEVELOPMENT\*

Water has a range of values that must be recognized in selecting governance strategies. Valuation techniques inform decision-making for water allocation, which promote sustainable social, environmental and economic development as well as transparency and accountability in governance. Development agendas and partnerships should recognize the fundamental role that safe drinking water and basic sanitation play in economic and social development.

### Targets:

- Develop further an open trading and financial system that is rule-based, predictable and non-discriminatory, includes a commitment to good governance, development and poverty reduction – nationally and internationally
- Address the special needs of landlocked and small island developing states

### WWDR2 Water-related Indicators:

- Water sector share in total public spending
- Ratio of actual to desired level of public investment in water supply
- Rate of cost recovery
- Water charges as a percent of household income

See Chapter 12: *Valuing and Charging for Water*

- Water interdependency indicator
- Cooperation indicator
- Vulnerability indicator
- Fragility indicator
- Development indicator

See Chapter 11: *Sharing Water*

- Disaster Risk Index
- Risk and Policy Assessment Index
- Climate Vulnerability Index

See Chapter 10: *Managing Risks*

- Progress toward implementing WRM

See Chapter 2: *Challenges of Governance*

\* Only the most relevant targets have been listed for this goal.



(UNESCO, 2006:30)