

## CHAPTER 2: METHODOLOGY



**Rietfontein pump station near Kriel**

*Water is pumped from the Rietfontein pump station towards Matla power station for use in power generation.*

## **2 Overview of a Water Distribution Scheme**

### **2.1 Preamble**

In this chapter the potential for a sustainable DSM project on the Department of Water Affairs (DWA) water distribution schemes will be investigated. The reader will thus be familiarised with the problems encountered by the implementation of such a project. The Usutu-Vaal water scheme, which serves to deliver water to those locations with the demand thereof, will serve as the case study for the investigation.

The water pumping system and storage facilities will be simulated to determine if savings are feasible and whether these savings will be sustainable. This simulation will take into account the different factors associated with the water scheme, such as water supply to power stations etc.

### **2.2 Typical water distribution system**

#### **2.2.1 South Africa's water demand problem**

South Africa is a relatively dry country with an annual average rainfall of only 464mm, which is almost half of the world average of about 860mm per year [35]. South Africa thus, due to its large population, has less water per person than other neighbouring countries, which are considered to be much drier [36].

Figure 13 illustrates that South Africa has merely a small area along the eastern coastline which receives a mean annual rainfall of more than 800mm. The rest of the country is considered to be arid and semi-arid.

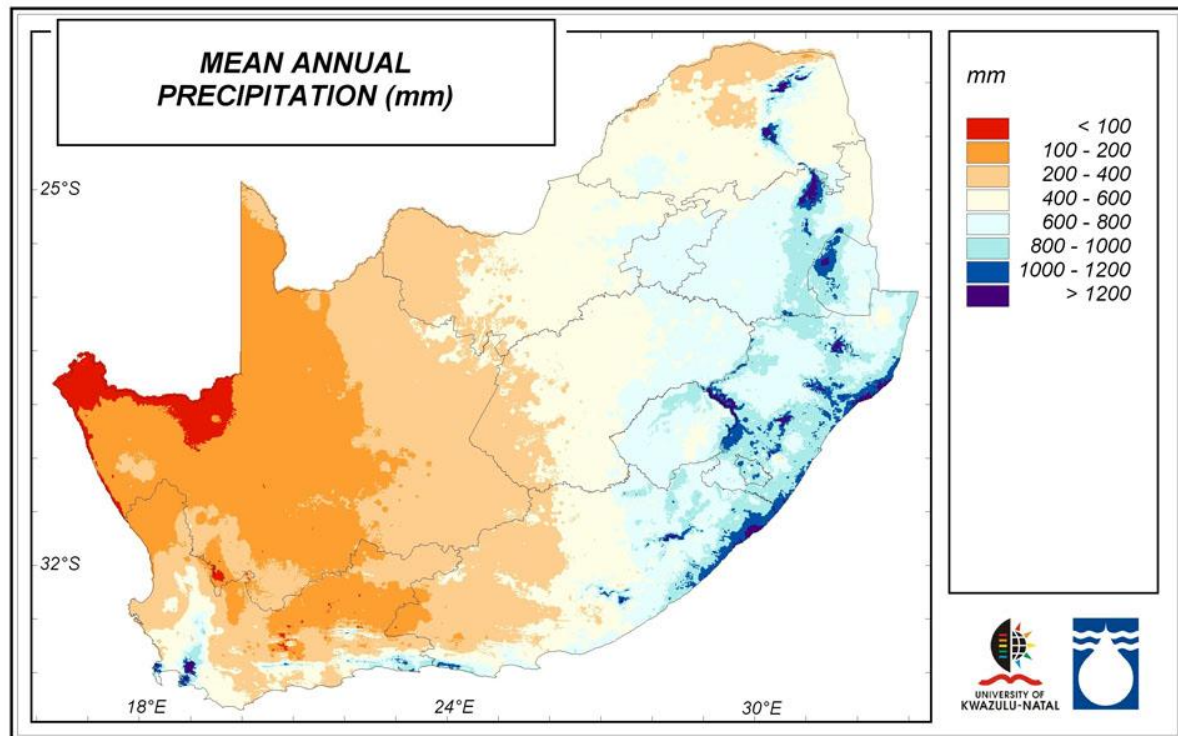

**Figure 13:** South Africa mean annual rainfall [53]

Figure 13 indicates that a large part of the country receives less than 500mm of rain annually. It is therefore essential that water consumption in South Africa is managed efficiently. The South African government has therefore established various intervention groups to efficiently distribute the available water within the country.

### 2.2.2 Water consumers

DWA has to distribute water to various consumers, one of which is the public. In 2000 the DWA introduced the Free Basic Water policy. This provided for every household in South Africa to receive 6 000 litres of water monthly free of charge. This amounts to 50 litres per person per day in a household of 4 persons [37].

Drinking water is obtained from two sources, namely: surface and ground water. Surface water includes water obtained through rainfall and its runoff into rivers and dams, whereas groundwater is water extracted from underground stores of aquifers through means off boreholes, fountains, etc. The drinking water is transported from its

source to a water treatment facility where it is treated by various processes. This water is then stored in reservoirs or tanks from where it gets distributed to the consumer.

Other water consumers include power stations, agriculture and major industries. Figure 14 illustrates the different consumers and their respective usages.

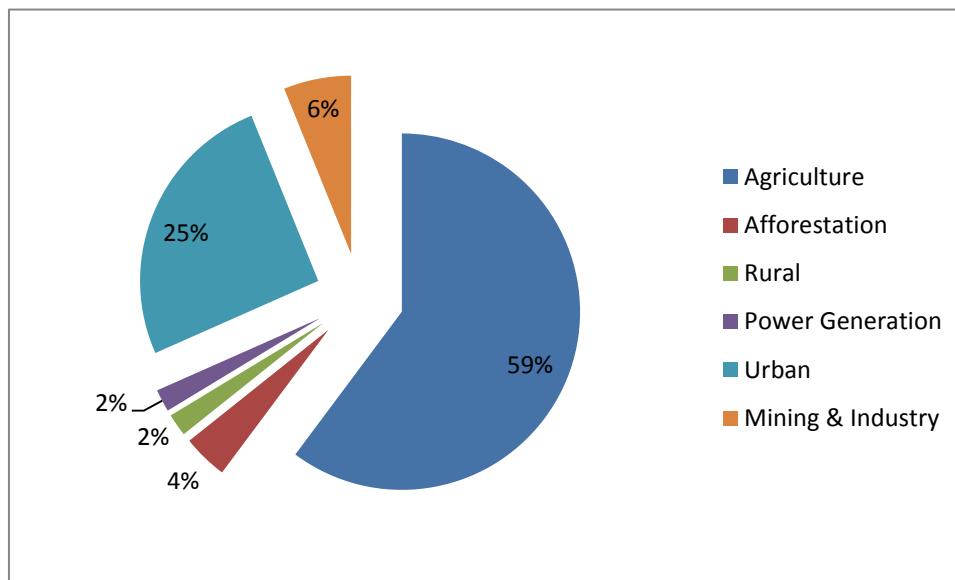

**Figure 14:** Different water consuming sectors [55]

A water distribution scheme provides all these sectors with water. Water extracted from a river or dam is pumped via canals or streams to other storage facilities such as dams and reservoirs. These dams or reservoirs then supply the consumers in that area with water.

### 2.2.3 The Usutu-Vaal water distribution scheme

South Africa is divided into 19 water catchment areas (Figure 15), where water is transferred to different areas to ensure ample water availability for national key important instances, as discussed earlier. Of these, power stations (Eskom) and the Sasol entities (Synfuels) are the most important [38].

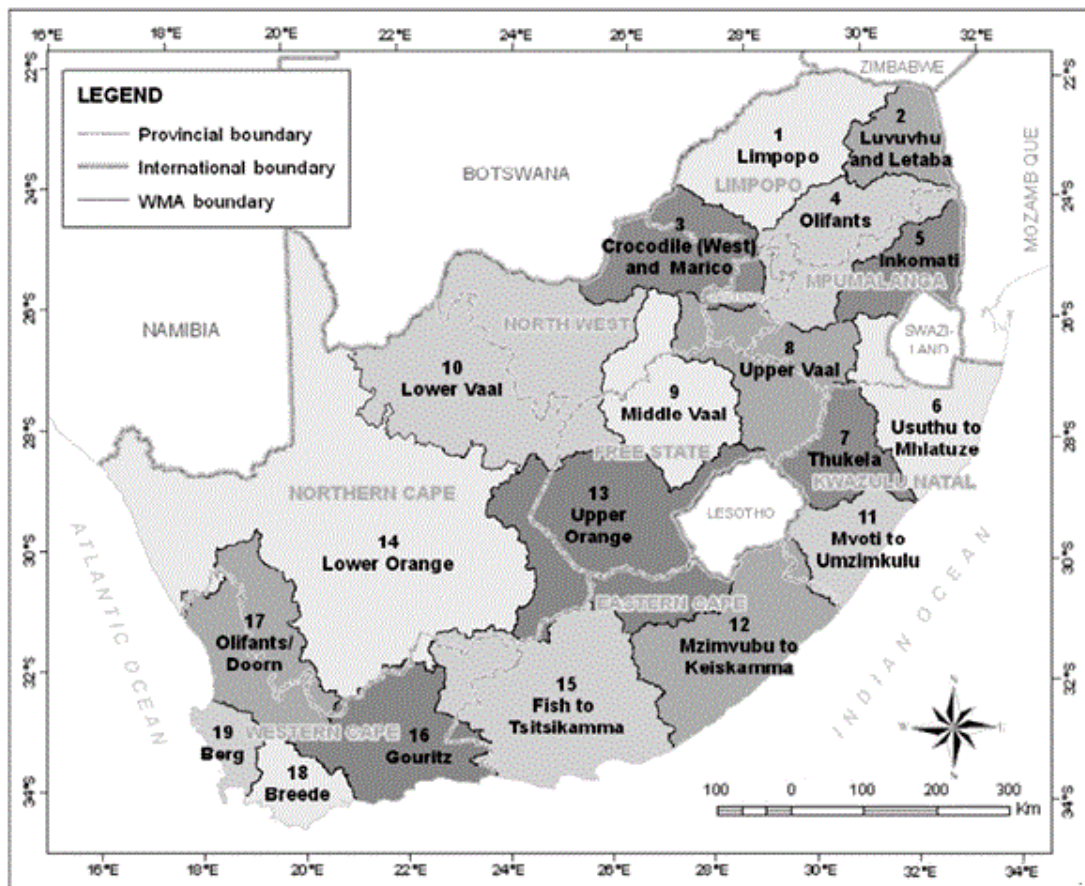

Figure 15: South Africa's water catchment areas [39]

The Usutu-Vaal water scheme, shown in Figure 15 area #4, and its various pump stations will be investigated in this dissertation.

## 2.3 Investigation and simulation results

### 2.3.1 DSM investigation methodology

In this section, the main focus will be on the Usutu-Vaal water distribution scheme and the potential for a DSM project. The impact of a DSM intervention will also be investigated.

The first step in any DSM investigation is to identify a potential project as well as the responsible client. In this instance, the client pumps large quantities of water. This requires pumping equipment with large installed capacities. Large storage facilities in the Usutu-Vaal scheme present ideal opportunities for a DSM project.

After a client has been identified, an initial investigation will be carried out by an ESCo. If the initial investigation indicates DSM potential, a more detailed investigation will be conducted. The following information will normally be obtained by the ESCo in a detailed investigation:

- the number of pumps and pump stations,
- the installed capacities of the pumps,
- water storage facilities and their respective sizes,
- a detailed layout of the system,
- water flow in and out of the system,
- average hourly power consumption of the system on a typical day,
- the clients tariff structure.

### **2.3.2 The Usutu-Vaal DSM investigation**

The various Usutu-Vaal pump stations are:

- Grootdraai pump station near Standerton,
- Grootfontein pump station near Charl Cilliers,
- Rietfontein pump station near Kriel and
- Naauwpoort pump station near Witbank.

These pump stations and their supply regions are shown in Table 1.

**Table 1:** Usutu-Vaal pump stations [40]

Pump station	Pumping to	Number of pumps
Grootdraai	Grootfontein pump boost station	4 Main
	Tutuka power station	4 Booster 4 Main
Grootfontein	Knoppiesfontein Tower	5 Main
Rietfontein dam	Matla power station	4 Main
Naauwpoort	Duvha power station	11 Main

### 2.3.2.1 The Usutu-Vaal process

The Grootdraai pump station has two sets of pumps as illustrated in Figure 16. The first of these pumping stations, namely the Grootdraai pump set, pumps water to Grootfontein, whereas the second pumping station called the Tutuka set provides water to the Tutuka power station. The Tutuka Power station consists of two dams, each with a capacity of 450 ML. Water is transferred from Grootdraai to Grootfontein by means of a canal. The Tutuka pump set consists of four main pumps, each with a booster pump, giving a total of eight pumps. A booster pump works in cooperation with a main pump and as the name suggests, boosts the pressure of the water through the pumping line, increasing the flow.

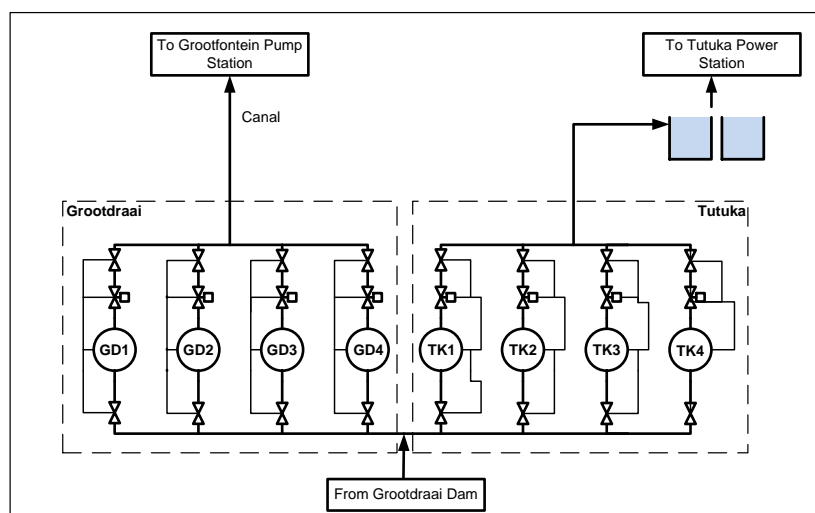
**Figure 16:** Grootdraai & Tutuka layout

The water from Grootdraai, which is transferred to Grootfontein pump station, is then pumped to the Knoppiesfontein towers via five pumps as illustrated in Figure 17. These pumps are considered part of the Grootfontein pump system and are located at the Grootfontein pump station.

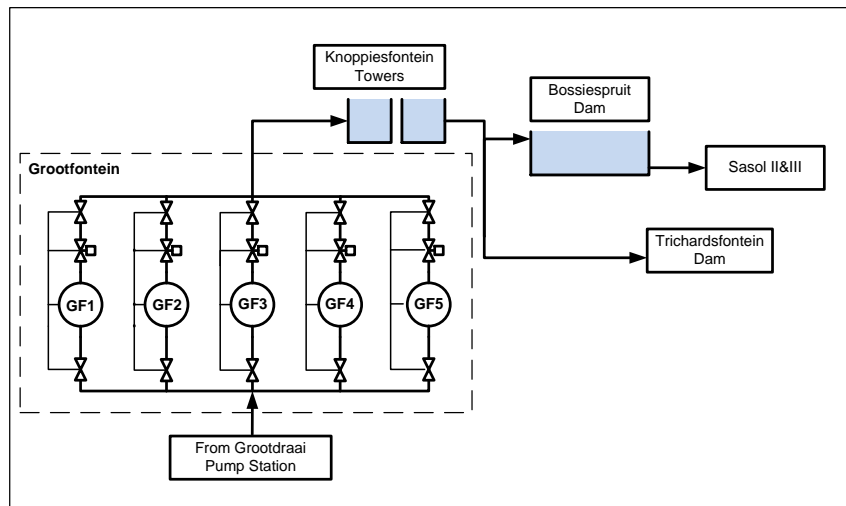

**Figure 17:** Grootfontein layout

From Knoppiesfontein tower the water is gravity fed to the Bossiespruit dam for Sasol II and III and to the Trichardsfontein dams. Water is supplied from the Trichardsfontein dam to Rietfontein dam by means of a river.

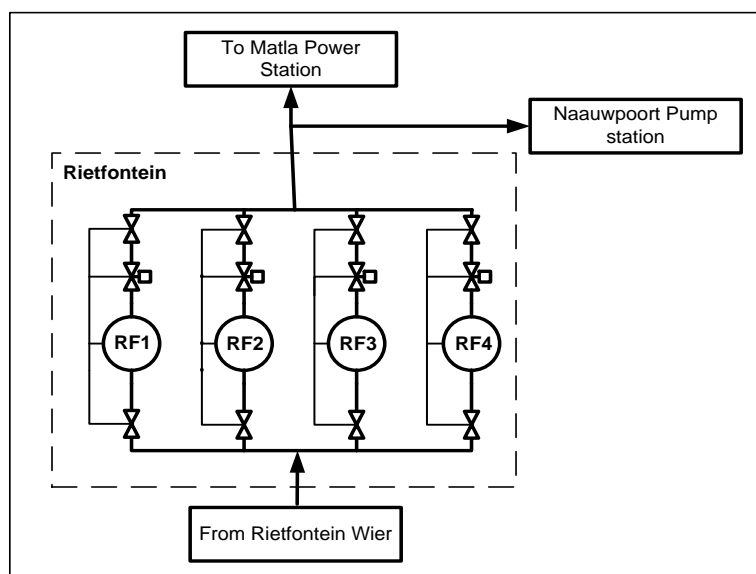

**Figure 18:** Rietfontein layout

The Rietfontein system consists of four pumps where water is pumped to the Matla Power station (Figure 18). Water can be distributed from Matla to Kriel and Kendal Power stations if required [41]. Rietfontein also supplies the Naauwpoort Pump station which in turn supplies water to the Duvha Power station.

The respective water storage facilities and their capacities are demonstrated in Table 2. The table also demonstrates minimum and maximum dam levels. These levels are not allowed to be exceeded under any circumstances.

**Table 2:** Usutu-Vaal dam storage capacities [40]

Dam\Storage	Capacity [ m <sup>3</sup> ]	Wall Height [m]	Min level	Max level
Grootdraai	354 x10 <sup>6</sup>	42	90%	98%
Tutuka (2 x)	2 x 0.45 x10 <sup>6</sup>	10 & 6	80%	95%
Grootfontein canal	N/A	N/A	1 m	3 m
Knoppiesfontein towers	1 300	16	2.5 m	12.5 m
Bossiespruit	2.289 x10 <sup>6</sup>	12	80%	95%
Trichardsfontein	15.496 x10 <sup>6</sup>	24	90%	98%
Rietfontein	0.599 x10 <sup>6</sup>	9.3	99%	80%
Matla	0.885 x10 <sup>6</sup>	9	80%	97%
Witbank	104.019 x10 <sup>6</sup>	42		
Duvha	0.885 x10 <sup>6</sup>	11	80%	97%
Boskop	20.850 x10 <sup>6</sup>	18		

A simplified layout of the Usutu-Vaal water scheme and all its pump stations are shown in Figure 19. This schematic layout demonstrates each pump station with its pumps and storage facilities, as well as the destination of the water being transferred to the different locations.

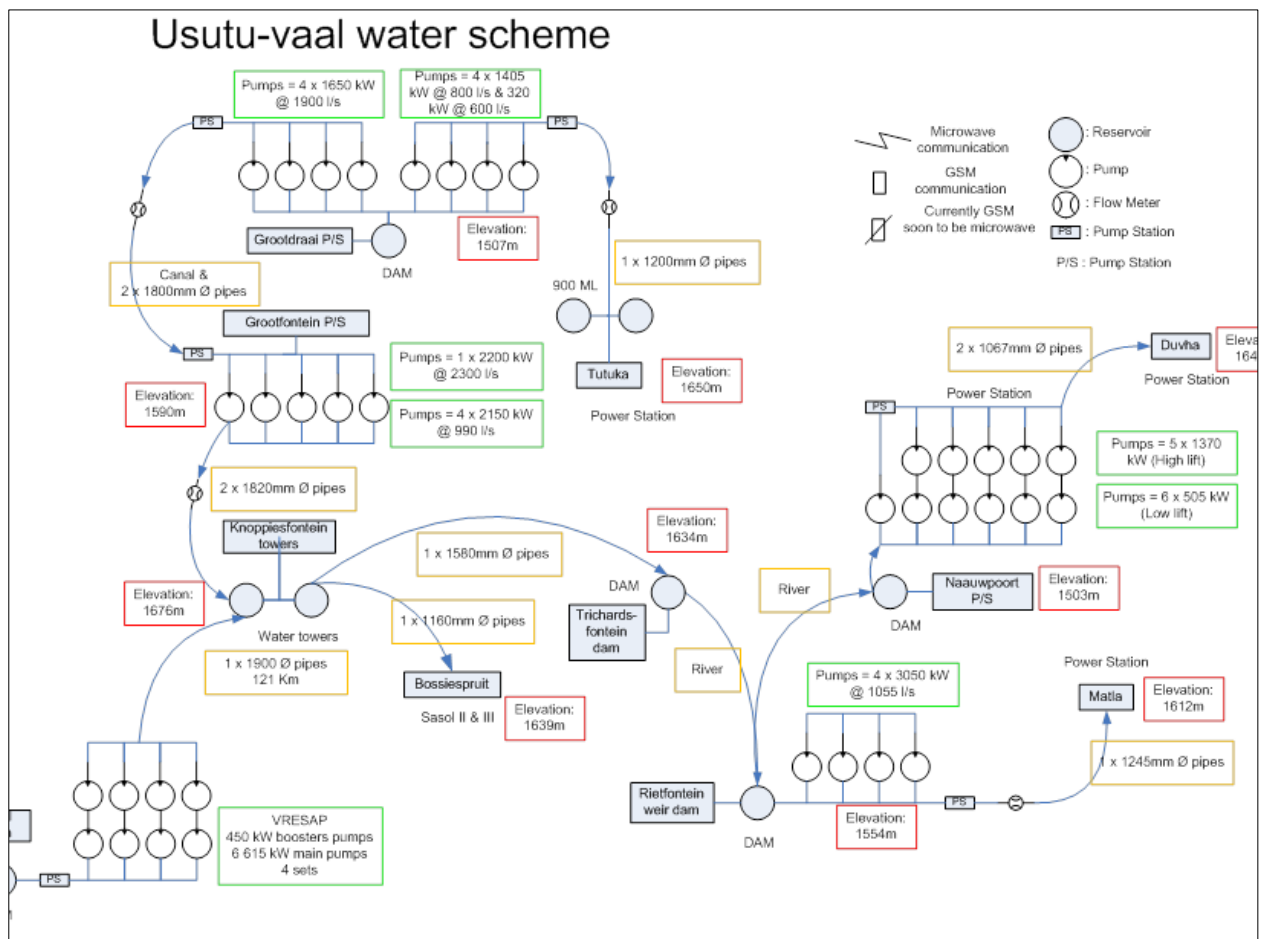

Figure 19: Usutu-Vaal water scheme layout

2.3.2.2 Usutu-Vaal pump station specifications

Table 3 exhibits the installed pump capacities of the Grootdraai Pump station. A total of twelve pumps are located at this station, of which four are on the Grootdraai side and eight on the Tutuka side (Table 1). Each pump on the Grootdraai side has a flow rate of 1 900 l/s at a head of 70m, and an installed capacity of 1 650 kW each. Two pumps are located per line at the Tutuka side as explained previously. These pump sets deliver a flow of 1 400 l/s at a head of 165m each, with the main pumps and booster pumps all having installed capacities of 1 405 kW and 320 kW respectively. None of the pumps on the Usutu-Vaal pump station are automated.

Table 3: Grootdraai pump station installed capacities

Pump set name:	Number of pumps	Installed capacity [kW]
Grootdraai 1-4	4(Main)	1 650
Tutuka 1-4	4(Main)+4(Booster)=8	1 405 and 320

Five pumps are located at the Grootfontein pump station of which four have installed capacities of 2 150 kW. Pump number five has an installed capacity of 2 200 kW. These pumps deliver a flow rate of 2 100 l/s at a head of 85m each. Only one pump is installed per line at Grootfontein.

The Rietfontein pump station consists of four pumps each with an installed capacity of 3 050 kW. Only one pump is installed per column and each pump delivers a flow of 1055 l/s at a head of 100m.

Naauwpoort pump station has eleven pumps (Table 1) and consists of two pump stations, namely a high lift pump station and a low lift pump station. Six of the pumps are in the low lift pumping station, each with an installed capacity of 505 kW. Only two of these pumps may run simultaneously. The high lift pump station has five pumps each with an installed capacity of 1 370 kW. Only one pump may be operational at this pump station at any one time. Table 4 gives both the high- and low lift pump capacities found on the Naauwpoort pump station.

**Table 4:** Naauwpoort pump station installed capacity

<b>Pump station:</b>	<b>Installed capacity [kW]</b>
Low lift pumps	6x 505
High lift pumps	5x 1 370

The water in- and out flows of the system were identified to obtain a better understanding of the system. The actual flow of these pump stations are illustrated in tables 5 to 7. Table 7 illustrate two scenarios at Rietfontein pump station; that is to say when the pumps are running at either high- or low speed.

By running the pumps on high speed a higher efficiency is achieved as the rotational speed of the impeller is increased [42]. High speed requires that no less than three pumps run simultaneously at the Rietfontein pumping station. If this is not done, the permitted maximum pump motor amperage would exceed the limit. This would result in

a pump trip which may cause damage to the pumps. Subsequently, Table 7 does not illustrate values for less than 3 pumps running on high speed mode.

**Table 5:** Grootdraai pump station flow rates

<b>No. of pumps:</b>	<b>1</b>	<b>2</b>	<b>3</b>
<b>Grootdraai Flow [l/s]</b>	1440	2840	4130
<b>Tutuka Flow [l/s]</b>	1160	2420	3240

**Table 6:** Grootfontein pump station flow rates

<b>No. of pumps:</b>	<b>1</b>	<b>2</b>	<b>3</b>
<b>Flow [l/s]</b>	2300	3800	4900

**Table 7:** Rietfontein pump station flow rates

<b>No of pumps:</b>	<b>1</b>	<b>2</b>	<b>3</b>
<b>Flow (low speed) [l/s]</b>	1030	1650	1950
<b>Flow (high speed) [l/s]</b>	n/a	n/a	3600

### 2.3.3 Analysis of existing power consumption

When determining the load shift potential of a DSM intervention it is standard practice to obtain at least three months' data before an accurate power baseline can be calculated. However, in general, more than three months of data are collected and evaluated in order to obtain the maximum load shift potential.

Great care had to be taken in selecting the most representative months for the Usutu-Vaal water scheme since there are five pump stations present. The months investigated at the five different stations had span the precise and identical periods of time for the results of the investigation to be accurate. The baseline was developed as the average hourly weekday power consumption for the time period from 1 June 2011 to 31 August 2011. Data for weekend days was also required because of the possibility

that the load could be shifted out of peak periods into weekend off-peak periods, due to the large amount of potable water storage facilities available for the pump stations.

### 2.3.3.1 Grootdraai i& Tutuka pump stations

The Grootdraai & Tutuka pump station consists of eight pump columns. Each Grootdraai column has an installed capacity of 1 650 kW. A Tutuka column consists of two pumps (one main pump and one booster pump) with a combined installed capacity of 1 725 kW per column. This results in a total installed capacity of 6.6 MW on the Grootdraai section of the pump station and 6.9 MW for the Tutuka section. Only four pumps may be operated simultaneously on this pumping station, as more pumps would exceed the electrical substations' maximum load capacity.

Baselines for both Grootdraai and Tutuka were calculated using pump data obtained from logbooks. The processed profile for the Grootdraai & Tutuka baseline is illustrated in Figure 20. Baseline data for all the pumping stations could be found in Appendix B.

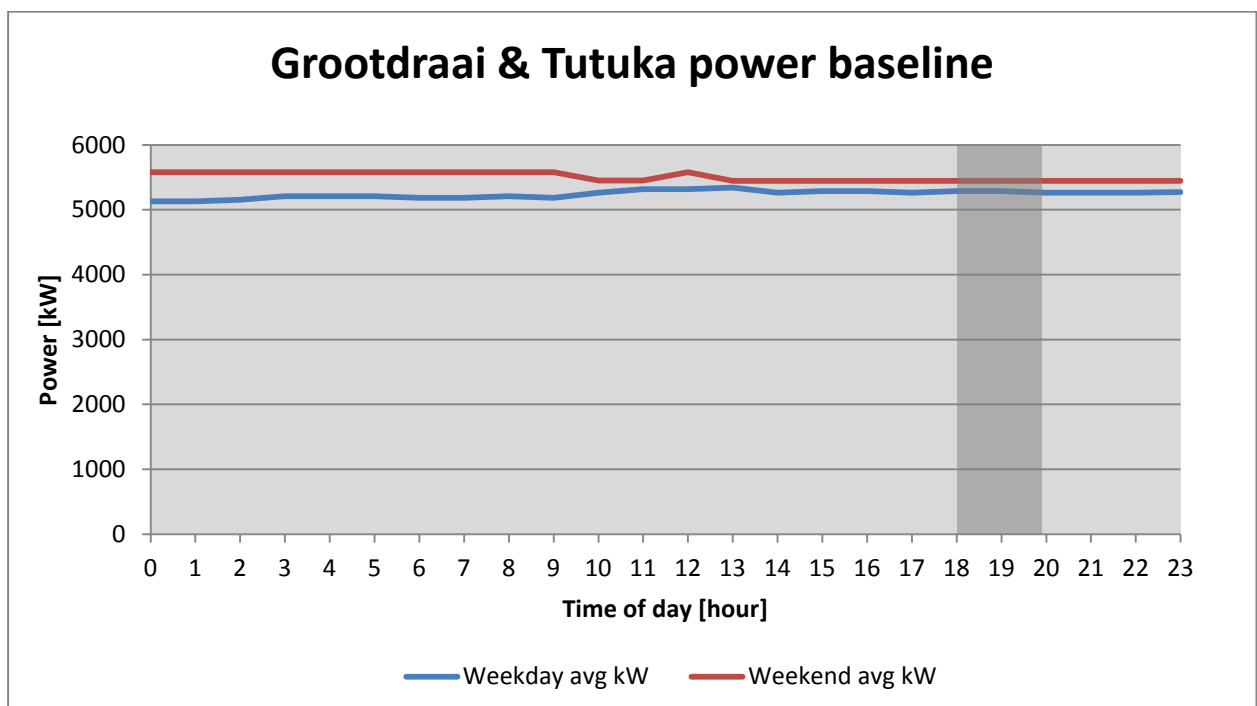

**Figure 20:** Grootdraai & Tutuka power baseline

The figure illustrates that the pumping station consumes just over 5 MW of power on average throughout a weekday. This calculates to three pumps running throughout the day.

By starting an additional pump during the off-peak and standard time period of the day, the possibility of stopping all the pumps between 18H00 and 20H00 will exist on the pump station. An average evening electricity load shift of approximately 5 MW is possible between 18H00 and 20H00 for the Grootdraai and Tutuka pump station.

### 2.3.3.2 Grootfontein pump station

Grootfontein pump station has five pumps, each with an installed capacity of 2 150 kW, except for pump number five which has an installed capacity of 2 200 kW. This gives a combined installed capacity of 10.8 MW. The electrical substation only allows for four of these pumps to be operated simultaneously. Running more pumps would exceed the substation's maximum load capacity.

Baseline data was obtained from operator log sheets for the Grootfontein pump station. Figure 21 illustrates the Grootfontein power consumption profile.

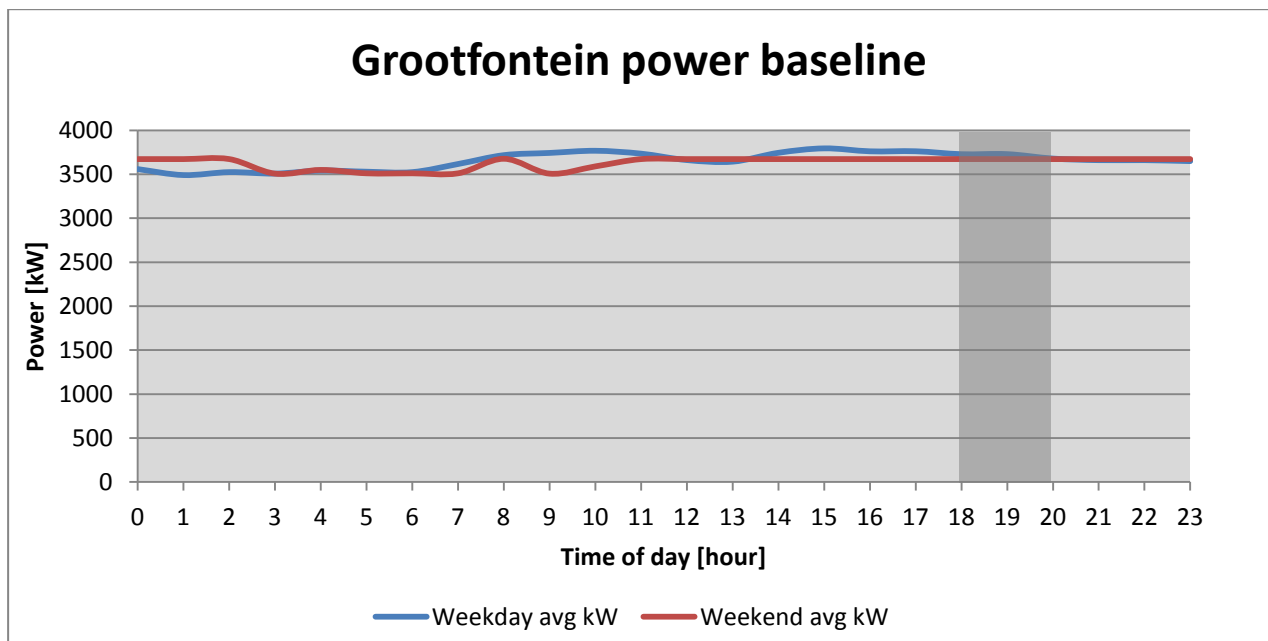
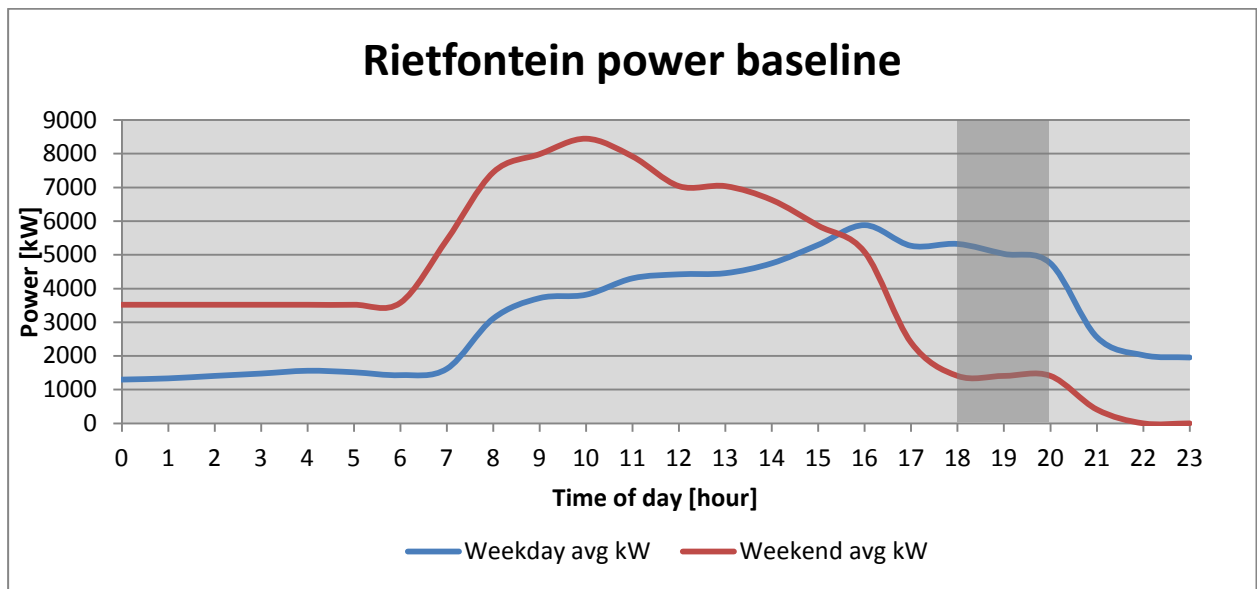

Figure 21: Grootfontein power baseline

As with the Grootdraai & Tutuka pump station, an additional pump could be started throughout the standard and off-peak periods. This will allow for the entire load to be shifted out of the evening peak time period. The data indicates that an average load shift of 3.5 MW during weekday evening peak periods is possible.

### 2.3.3.3 Rietfontein pump station

The Rietfontein pump station consists of four pumps, each with an installed capacity of 3 050 kW resulting in a combined capacity of 12.2 MW. The electrical substations maximum load capacity only allows for three pumps to be operated at the same time. Figure 22 shows the average power consumption profile for the Rietfontein pump station. This data was obtained from operator log sheets.



**Figure 22:** Rietfontein power baseline

The Rietfontein pump station baseline shows relatively large variations over a 24 hour period. The profile indicates that an average of approximately 5 MW may possibly be shifted out of the evening peak period into an off peak period by scheduling pumping outside of the Eskom evening peak period.

### 2.3.3.4 Naauwpoort pump station

The weekday power consumption profile for the Naauwpoort pump station can be seen in Figure 23. Water is extracted from the Witbank dam and pumped to Duvha power station during certain periods of the year. Duvha mainly receives its water from the Wintershoek reservoir. The Naauwpoort pumping station therefore only serves as a supplementing water supplier to the Duvha power station, if the water supply from Wintershoek is spent.

Only two low lift pumps and one high lift pump may be operational at the Naauwpoort pumping station at the same period of time. This is with the aim to not exceed the electrical substations maximum load capacity. No data were obtained for weekends as the weekday power consumption profile is relatively low and the load will not be shifted into weekend periods.

Due to the relatively small quantities of water pumped from this pump station, the power baseline is also relatively low. Figure 23 indicates that an average of approximately 1 MW can be shifted out of the evening peak period. Data used to plot these figures can be found in Appendix B.

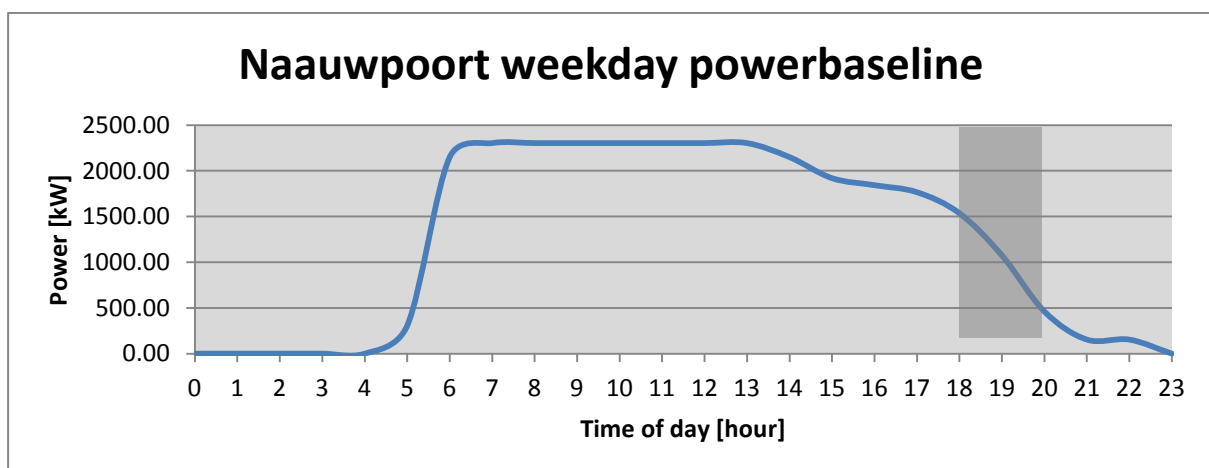
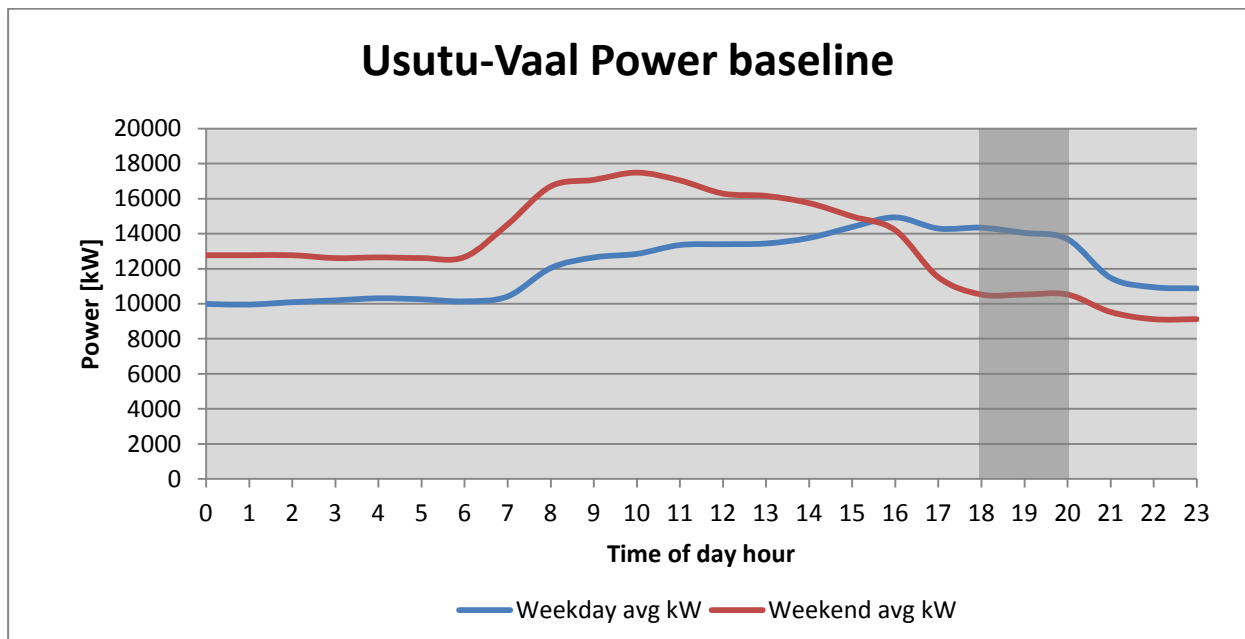

Figure 23: Naauwpoort power baseline

This relatively low baseline and due to the fact that pumping occurs merely over short periods during the winter months, resulted in the conclusion that there is presently no

significant potential for DSM intervention. This dissertation will therefore only focus on the other pumping stations.

For the three remaining pump stations, the reader will note that Figure 24 illustrates that an average weekday peak period load shift of about 14 MW exists for the Usutu-Vaal system as a whole.



**Figure 24:** Power baseline for all three pump stations

After establishing that the potential for a DSM project exists, a simulation model of the system must be developed. This will determine whether the project is feasible and will also quantify the expected cost and energy savings generated by the intervention.

### 2.3.4 Simulation results

An initial, provisional simulation was completed, using Microsoft Excel, to determine the feasibility of the project. The performance of each individual pump station was computed for the project. Upon completion a simulation of the system as a whole was prepared using REMS (Real-time Energy Management system). This is explained in section 2.5.2 of this document.

Figure 25 to 27 illustrates a proposed electrical energy usage profile called the “proposed baseline” for each of the pump stations. This takes into consideration the maximum number of pumps allowed to run simultaneously at each pump station, as well as dam level percentages. Data used to plot Figures 25 to 27 are displayed in Appendix B.

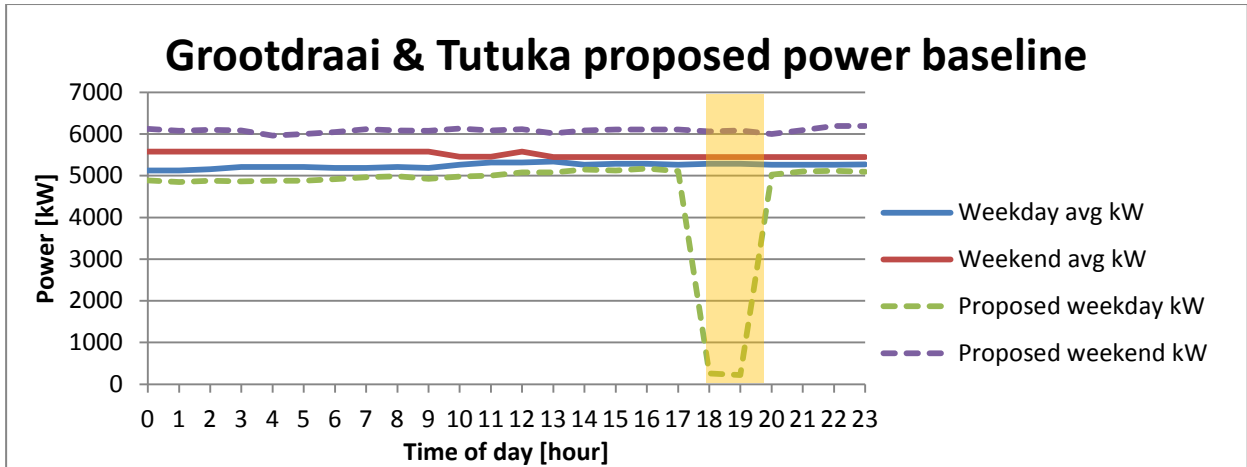

Figure 25: Proposed Grootdraai & Tutuka profile

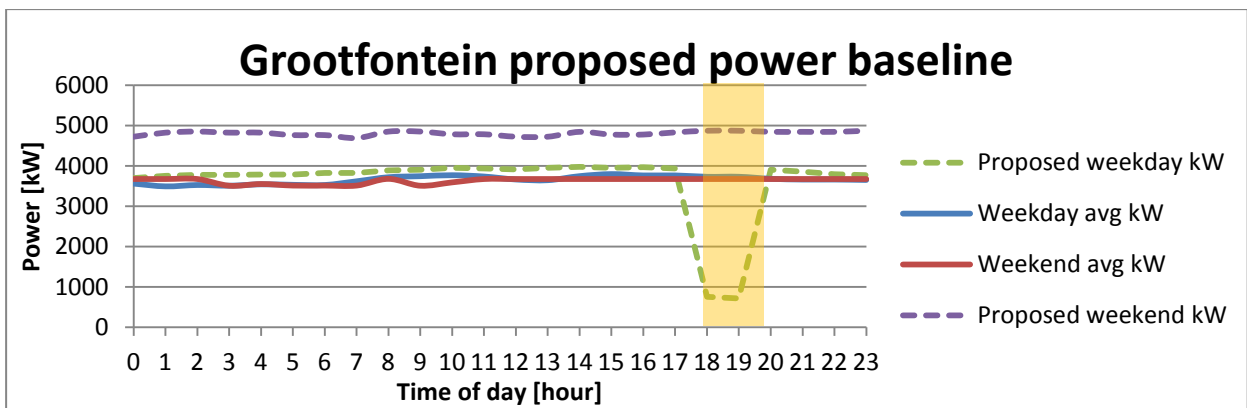

Figure 26: Proposed Grootfontein profile

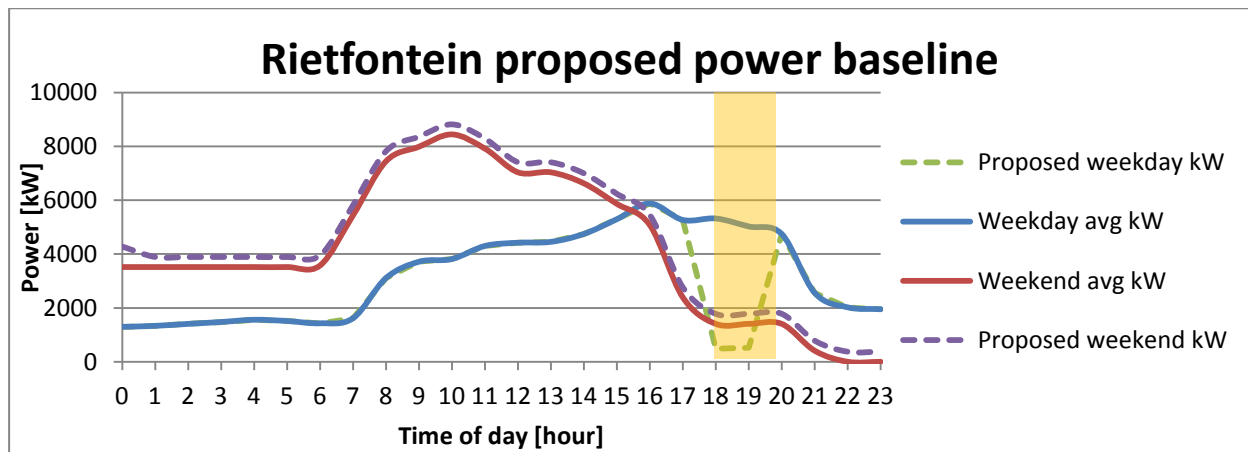

Figure 27: Proposed Rietfontein profile

The results show that different profiles are obtained from normal working weekdays and weekends. This is because water could be not only be shifted out of the weekday peak periods into off-peak and standard periods, but also into weekends, which is classified as off-peak periods [24].

## 2.4 Existing control systems and new requirements

### 2.4.1 Existing control system on Usutu-Vaal

Before the DSM intervention on the Usutu-Vaal water scheme, the system was operated by making use of relay logic control. This is a very complicated method to control the system and the operator has to perform all tasks manually. For example, if a pump operator wanted to start a pump he would have had to abide to the following procedure:

- 1 Start the motor oil-cooling heater and wait 15 minutes;
- 2 Start the motor oil-cooling pump;
- 3 Check oil temperature;
- 4 Open the delivery valve and wait until open;
- 5 Open the suction valve and wait until open;
- 6 Sound an alarm indicating that a pump is about to be started;
- 7 Activate the pump motor;

- 8 Check if all pump temperatures and vibrations are in allowable range;
- 9 Open the control valve;
- 10 Check if all pump temperatures and vibrations are in allowable range;
- 11 Wait 10 minutes for water hammering in pipes to stop before starting next the next pump;
- 12 Check if all pump temperatures and vibrations are in an allowable range and repeat every 30min;

This involves a number of operations and leaves ample opportunity for errors to be made. Another disadvantage of relay logic is that data cannot be stored and the operator has to log these values by hand.

Figure 28 demonstrates an existing relay logic panel used by the operator to operate the pumps on the Grootfontein pumping station. Figure 29 demonstrates the vast amount of hard wiring assembled in this panel. This makes it difficult to make modifications in the system.



**Figure 28:** Grootfontein relay logic panel

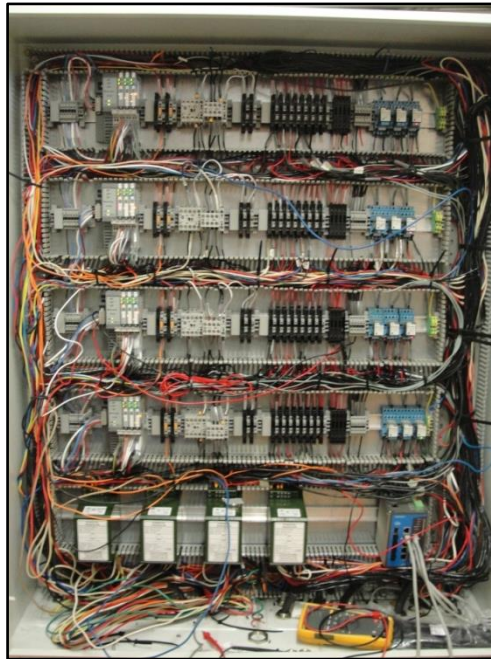

**Figure 29:** Relay logic wiring

### 2.4.2 Programmable Logic Controller (PLC)

A PLC is a freestanding electronic device used to control equipment. It is discerned as the fundamental component of most industrial automation processes. PLC's may be found in most industrial facilities, for example food processing machinery and conveyor systems.

The traditional control system operates by method of all control devices communicating directly with each other, depending on how the system is set-up. By introducing a PLC to the system the wiring between devices are simplified. All the equipment is connected directly to the PLC as opposed to each other [43]. The PLC then communicates and controls the various devices by utilising the control program inside of the PLC known as "soft wiring".

The control program is software that is stored in the PLC's memory which then commands the PLC to carry out certain instructions.

The advantages of using a PLC over a traditional control system are:

- The versatility of the PLC,
- high reliability,

- computing capabilities,
- small space requirements,
- reduced costs for modifications to the control system and
- the ability to withstand harsh environments.

A picture of a typical PLC is shown in Figure 30.



**Figure 30:** Programmable Logic Controller (PLC) [44]

### 2.4.3 Supervisory Control and Data Acquisition (SCADA)

The primary purpose of the SCADA system is to monitor and control plant or regional operating systems from a central location [45]. As implied by the term, this is not a full control system but rather a system that focuses on a supervisory level.

A SCADA acts as a centralised system that monitors and controls a network. SCADA's are made up of three basic elements [45], these are:

- PLCs,
- communications and
- Human-machine Interface (HMI).

Information is accumulated at each site by the regional PLC. This information is then continuously transferred to a central location by means of various communication structures. Instructions from the SCADA are then relayed back to the PLCs and the

PLC will control the system accordingly. Communications which transpire in the plant are usually transmitted by means of network cabling or optic fibre, while regional systems most commonly utilise wireless radio communications. This data is then processed by means of the HMI.

The PLC's control functions are predominantly restricted to basic over-ride or supervisory level capability. For example, a PLC controls the flow of water through a valve by opening or closing the valve according to a predefined set point. The SCADA system may, however, allow the operator to vary the control set point for the flow as well as other variants which may be included in the PLC by means of the HMI.

A typical SCADA layout is illustrated in Figure 31. In this figure, PLC-1 measures and compares the flow (F-1) to the specified set point given by the SCADA and then controls the pump speed (E-1) in order to coordinate these values. PLC-2 controls the level (L) to the set point and then controls the flow through the valve (V-2) to correspond with the level set point. In the figure the SCADA system reads and logs the measured flow and level, and sends the required set point values to the PLC's.

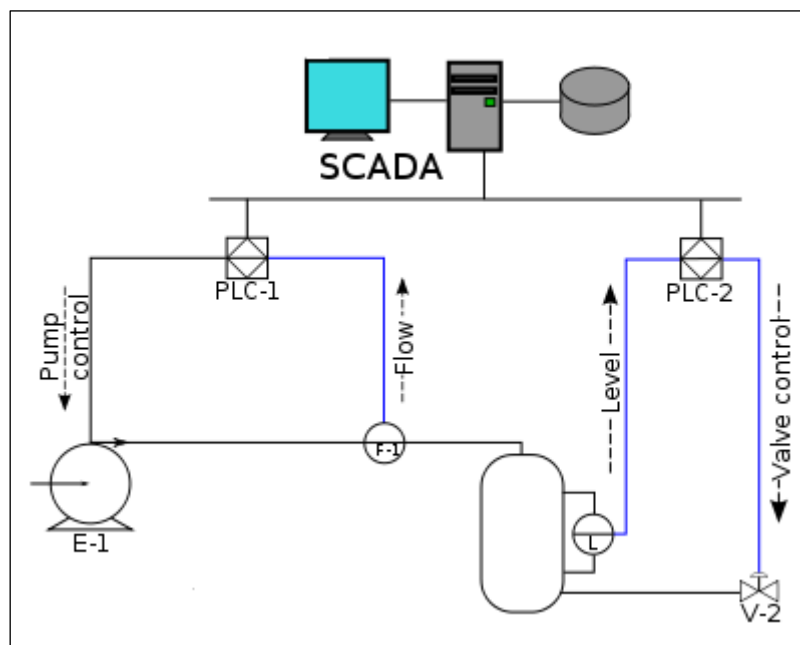

**Figure 31:** Example of a SCADA layout [46]

#### **2.4.4 Human-Machine Interface (HMI)**

An HMI, or Human-Machine Interface, is a device which enables a user to communicate with a machine or automation system. The HMI relays the user's commands and translates complex data into usable information [47]. The HMI also connects the operator with the process being controlled by providing alerts, information, commands and other tools.

The HMI is then linked to a database and provides diagnostic data, data trending and information such as logistic information and scheduled maintenance procedures.

### **2.5 Developing an optimised Real-time Energy Management System**

#### **2.5.1 Background**

REMS or Real time Energy Management System was developed by HVAC International to control electrical energy demands in the mining industry. Some of these applications include the automation of winders, pumps, refrigeration plants, etc. Due to the versatility of the REMS system, it can easily be adapted to automate the Usutu-Vaal system and ensure that the system shifts load out of the daily peak periods.

Presently pumps are operated by operators at each pump station of the Usutu-Vaal water scheme. These operators receive information on the fluctuating capacity of the dams in the system via another individual positioned at the dam. The operator then has to make a decision, taking into account all the different factors regarding the system, whether he needs to start or stop pumps at the pump station. REMS can fully automate a system and replace a control room operator with a computer driven control system.

The REMS program emulates the operator by communicating the appropriate information to a SCADA. The SCADA sends all the necessary data such as dam levels to the control module of REMS. A control algorithm is then utilised in the scheduling of the operational periods of the pumps in real-time. Essential data such as minimum and maximum dam level constraints are set up in the REMS system. It then switches the

allocated pumps on or off depending on whether that dam level reaches the upper or lower limit.

Other factors such as pump availability, pump status, time of day and whether it is a weekday or weekend, are all monitored by the REMS system. The real-time management of the system is dependent on all of these factors to successfully schedule pumping to off peak periods.

If a dam level exceeds a constraint specified by the REMS system the following would occur:

1. REMS monitors the SCADA and identifies the dam where the level is too low;
2. REMS determines the availability of pumps allocated for that dam taking into account the maximum amount of pumps which may be in operation at that specific time of day;
3. By using the control algorithm, REMS determines which pumps must be switched on;
4. REMS then commands the PLC to switch on the pump
5. The PLC turns on the pump
6. REMS monitors the pumps and confirms if it is running

This is done continuously by the REMS system which then controls the pumps accordingly.

### **2.5.2 The Real-time Energy Management set-up**

REMS is a component based software package that makes use of drag and drop methodology. The program has specific icons for all the devices under its control, where each of these icons has its own function. These icons, such as dams and pumps, can be dragged and dropped to any position on the REMS screen as laid out by the user. Figure 32 illustrates the layout of the Usutu-Vaal system as an example.

Although the REMS software has already been developed, it is still necessary to set up each project individually, as each system is unique and has its own limitations. The REMS simulation software will also be used to verify the project potential.

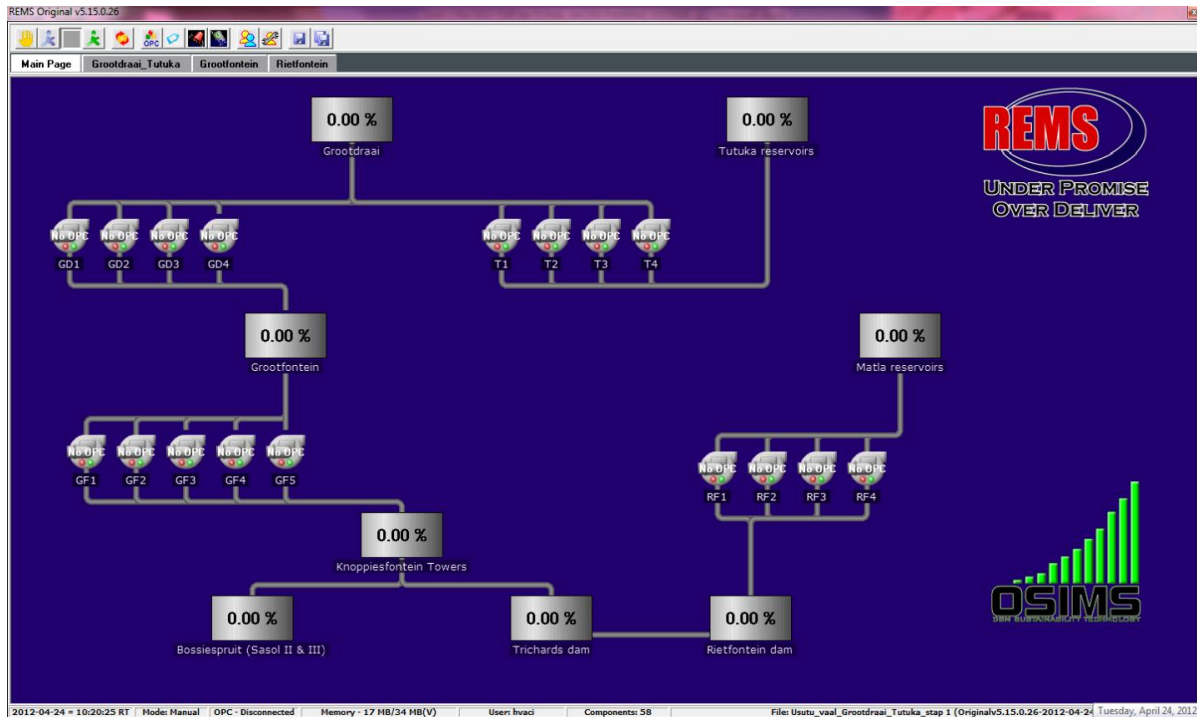

**Figure 32:** REMS Usutu-Vaal layout

When all the components of a pump station have been inserted and positioned, these icons have to be inter-connected by making use of the REMS built in functions. For this specific example, each of the dams is linked to the pumps prescribed for each specific dam as in Figure 33. Figure 33 illustrates how the Grootfontein dam editor is set up.

In addition to linking each pump to the relevant dams, other properties such as the dam maximum and minimum levels, etc. are also set up in this function.

**Description**

Grootfontein

Level Tag	0 / Tag /	<p><b>Filter Dam Level Fluctuations</b></p> <p><input type="checkbox"/> Filter Dam Fluctuations</p> <p style="margin-left: 20px;">Window: 0.0 %</p> <p><b>Display Settings</b></p> <p><input checked="" type="checkbox"/> Display Max and Min Levels</p> <p><input type="checkbox"/> Display Settler</p>
Temp Tag	0.00 / Tag /	
Volume	500000 m <sup>3</sup>	
Max Dam Level	98 / Fix	
Min Dam Level	60 / Fix	

**Simulation Values**

Simulated flow	2200 / Fix	l/s	Initial Simulation :	Level : 80	%	<input type="checkbox"/> Override Sim. Value with Level Tag
	1 / Fix	°C		Temp : 8	°C	
	<input type="radio"/> In-flow <input checked="" type="radio"/> Out-flow					

In Flows				Out-Flows			
Component	Cmpt Type	Valve Bound	Vlve Status	Component	Cmpt Type	Valve Bound	Vlve Status
GD 1	Pump			GF1	Pump		
GD 2	Pump			GF2	Pump		
GD 3	Pump			GF3	Pump		
GD 4	Pump			GF4	Pump		
				GF5	Pump		

**Figure 33:** REMS Grootfontein dam editor

As with the dams, each pump also has a function which needs to be edited. Physical properties of each pump such as flow rate, efficiency, etc. are read into the pump editor as shown in Figure 34.

**Description**  
GD1

**Control Properties**  
Hold Delay: 3 s  Reset on status change  
 Attempt Restart on Start Failure

**Display Colors**  
Standby:  Offline:  On:

**Tags**

Start Tag	<input type="text" value=""/>
	<input checked="" type="radio"/> Bit <input type="radio"/> Byte <input type="text" value="1"/> <input type="radio"/> Spec. Bits <input type="button" value="Select"/>
Stop Tag	<input type="text" value=""/>
	<input checked="" type="radio"/> Bit <input type="radio"/> Byte <input type="text" value="1"/> <input type="radio"/> Spec. Bits <input type="button" value="Select"/>
Availability Tag	<input type="text" value=""/>
	<input checked="" type="radio"/> Bit <input type="radio"/> Byte <input type="text" value="0"/> <input type="radio"/> Spec. Bits <input type="button" value="Select"/>
Status Tag	<input type="text" value=""/>
	<input checked="" type="radio"/> Bit <input type="radio"/> Byte <input type="text" value="0"/> <input type="radio"/> Spec. Bits <input type="button" value="Select"/>
Priority Tag	<input type="text" value=""/>
Start Permission Tag	<input type="text" value=""/> Def True
Stop Permission Tag	<input type="text" value=""/> Def True
Auto/Manual Tag	<input type="text" value=""/>
Trip Reset Tag	<input type="text" value=""/>

**Physical Properties**  
Power: 1650 / Fix kW  
Flow Rate: 1900 / Fix l/s  
Efficiency: 95 %  
Type: Sulzer  
Min Run Time: 30 min

**Copy Settings to/from pumps**

**Control Settings**  
 Enable Start Stop In Manual  
 Enable Start Stop In Auto  
Manual Startup Delay: 0 sec  
 Repeat Start Command after: 1200 sec  
 Repeat Stop Command after: 0 sec

Figure 34: REMS pump editor

After the dam and pump parameters have been read into the editors, a controller must be set up for each of the pump stations. As the term indicates, the controller controls the pumps. A controller will however only control the pumps specified by the user. The REMS3 controller takes all the required information it receives from the pumps and dams, such as pump statuses, availability and dam levels into account. Subsequently it controls the system by starting and stopping different pumps correspondingly to the information it receives from the PLC and SCADA devices.

Figure 35 shows how the REMS3 controller is set up and programmed according to the control parameters as requested by the client. The relevant pumps to be controlled are added to the controller.

Figure 35: REMS3 controller

The user may also make use of internal tags to force the controller to control pumps to the user's specifications. A user can program into an internal tag by using "if", "and", "or" and "else" statements.

The REMS3 controller offers a variety of controllability by allowing the user to configure the controller according to the days of the week, hours and minutes of the day. This is a major advantage as it allows the user to control differently during weekdays and weekends as required in the Usutu-Vaal project.

Another advantage of the REMS3 controller is the ability of the user to specify top and bottom offsets for the dams. This function effectively reduces pump start-ups and stoppages as it takes into consideration dam level fluctuation when a pump is started and stopped. This reduces pump cycling in the system which is caused by pumps switching on and off too rapidly.

When all of this has been completed, the REMS system has been set-up. The next step is to simulate the program in order to be able to optimise the system. The

simulation takes into consideration the dam in- and outflows as well as pumping flows and accordingly simulates the entire system, as shown in Figure 36.

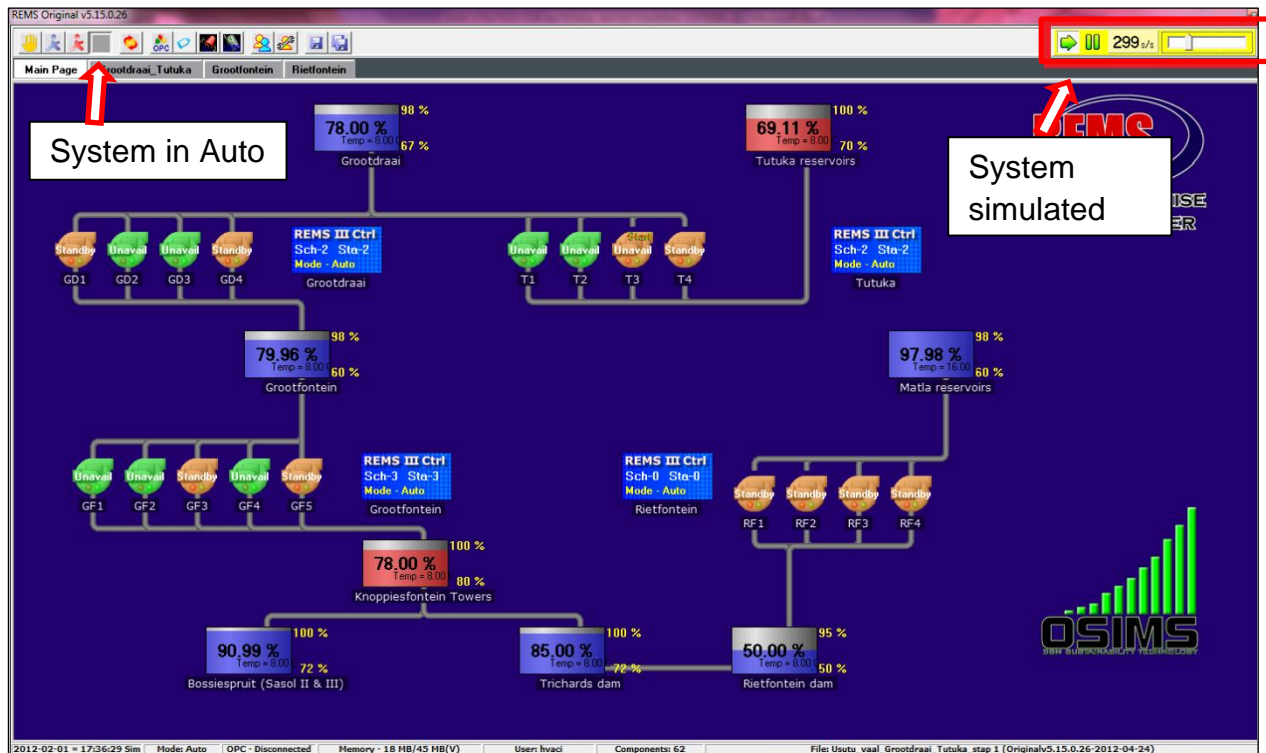

Figure 36: REMS simulation

This figure illustrates that the system is being simulated - as seen in the right-hand top corner - and that the system is in automatic mode, allowing the controllers to switch the pumps on and off. If the system were to be in manual mode, the red man icon at the top left-hand corner would be pressed and the system will not be able to control the pumps. The operator will now be required to do this manually.

A scenario has been simulated in Figure 36, where some of the dams are below their minimum levels as indicated in red (Tutuka and Knoppiesfontein) and others are above their maximum level (Matla reservoir). The controller identifies this and from the figure it can be ascertained that the pump stations, associated with the dams which are below minimum level, are running at maximum capacity as predefined by the user, while adhering to the system restrictions. The figure also illustrates that no pumps are in operation at Rietfontein pump station, due to the Matla reservoir being full.

As discussed earlier, the REMS system will use a control algorithm to determine the most cost effective manner of pumping. It will thus schedule the pumping out of the peak times, into the off-peak times where possible. In Figure 37 another scenario has been created where the system time is in the Eskom peak period between 18H00 and 20H00 on a weekday. One of the dam levels has however been simulated to be under the minimum dam level (Grootfontein).

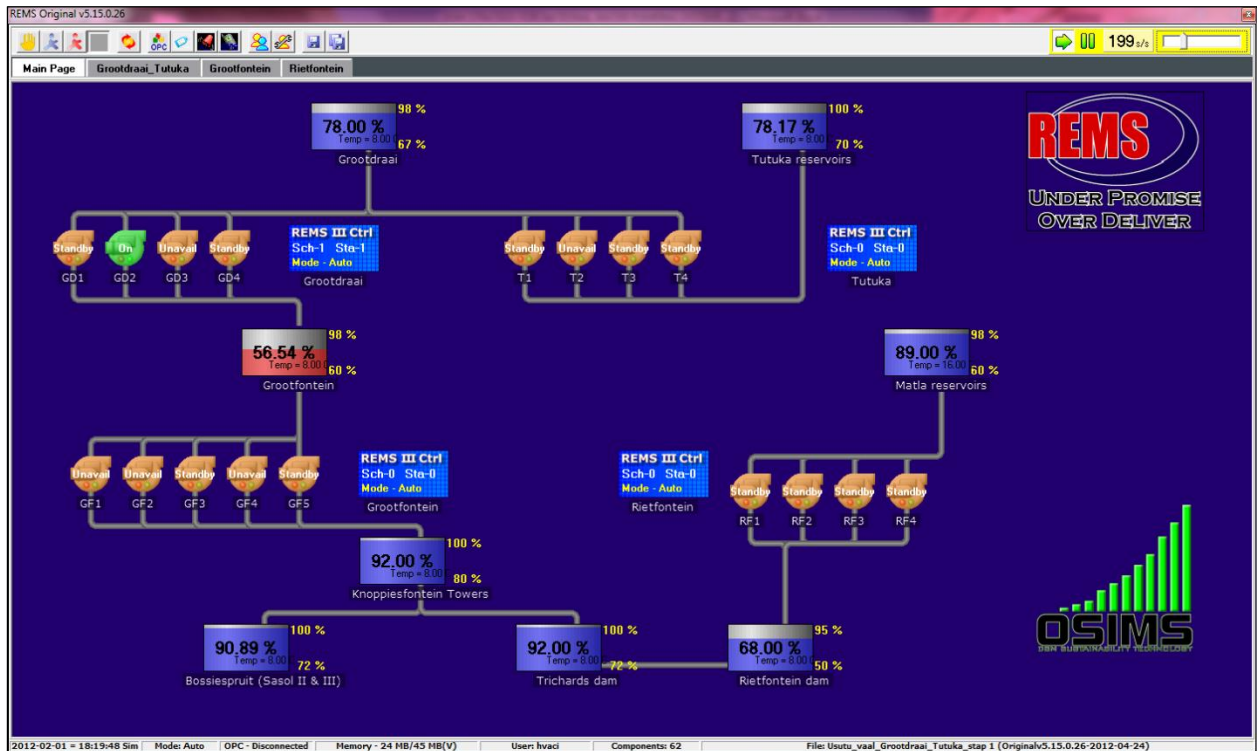

Figure 37: REMS simulation (peak time)

It can be ascertained that all the pumps, except one, shown in green, are switched off by the controllers. This is as a result of the simulated system time being in the Eskom peak-time period. The pump at Grootdraai pump station will be left on by the controller due to the Grootfontein dam being below the minimum level.

### 2.5.3 REMS additional features

By adding certain applications to the REMS platform such as generic data loggers and master loggers, the appropriate data can be logged for the simulated values which can then be compared to the original baseline.

Different meter panels and trend tools can also be added to the REMS platform. This allows the user to obtain different data and graphs from the system that the user may find useful. Figure 38 shows an example of the Grootdraai & Tutuka pump station with the different components which could be included into the REMS system. Appendix C contains the results of the simulations for each of the three stations.

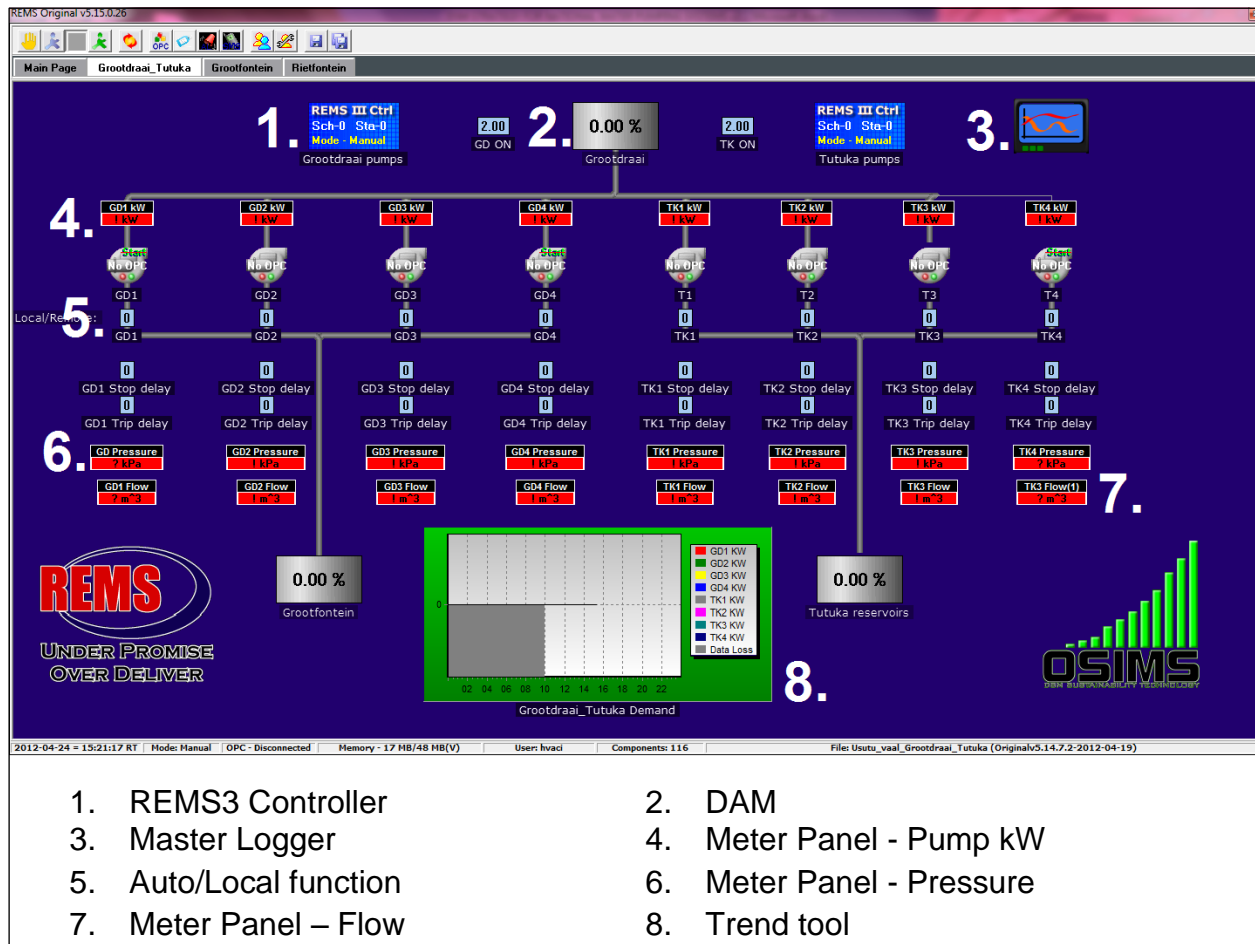

Figure 38: REMS platform functions

## 2.6 Conclusion

Low rainfall in most regions of the country has created a problem in water demand throughout South Africa. Various different water consumers were identified. To resolve this problem, a potential Eskom DSM intervention was investigated at the Usutu-Vaal Water Scheme which is used to supply water to consumers such as the Matla and Tutuka Power stations, as well as SASOL II and III. This investigation included the DWA Grootdraai, Tutuka, Grootfontein, Rietfontein and Naauwpoort pump stations.

All the pump stations' power consumptions were determined. A simulation program was used to determine the feasibility of a DSM project on the Usutu-Vaal Water Scheme. The existing control systems which were already installed on the pump stations were identified as well as infrastructure that would be required for implementation of an automated DSM project. It was explained how the REMS system was programmed according to the Usutu-Vaal water scheme. This was used to verify simulation results as well as to optimise the system for implementation