CHAPTER 3

RESEARCH FACILITIES

3. RESEARCH FACILITIES

3.1 GENERAL TECHNICAL INFORMATION

The characterisation of scientific and performance testing of the processes concerned in a modern steam power plant, in this case the influence of coal quality on the optimum combustion air, can be divided into five levels:

- Chemical and physical analysis
- Advanced analytical techniques
- Laboratory scale testing
- Pilot scale tests
- Full scale tests

Level 1 - Chemical and physical analysis

This category includes mass based proximate, ultimate and CV analysis of the coal on a gravimetric (mass) basis. Ash fusion temperatures and elemental (constituent) analysis are also included in level 1.

Level 2 - Advanced analytical techniques

These analyses are mostly on a petrographical basis. "Petrography is the study of the microscopic organic and inorganic constituents in coal and the degree of metamorphosis to which they have been subjected subsequent to their time of burial."⁽¹⁾ The Lethabo coal analysis according to this is approximately:

Vitrinite - 17,5%

Exinite - 2,5%

Inertinite - 80%

(Reactive macerals - 27%)

It involves fields such as mineralogy and char microscopy. Mineralogy is the analysis of the crystal structure of the mineral components (pyrite, siderite, SiO, Al₂O₃, etc.). Techniques such as FTIR and NMR (see nomenclature) are also included here.

Level 3 - Laboratory scale testing

This level includes combustion testing using the so-called hot stage microscope, heated grid and flat flame techniques, thermogravimetric analysis (TGA) where the mass loss is determined vs. T or t, which can be performed in N₂ to devolatilise, or O₂ to combust, DSC, RC, DTF methods. (See nomenclature).

Moving from level 3 to 4 is the transition of microscopic to macroscopic approach. To obtain directly usable results to fulfil an operational need, the macroscopic approach (more specifically plant performance techniques in the form of Process and Thermal Efficiency Optimisation) is primarily required for this project. This should also serve as a link between the macroscopic and microscopic approaches.

Level 4 - Pilot scale tests

These are mostly performed on dimensionally similar burners, but are unfortunately relatively expensive.

Level 5 - Full scale tests

These tests are performed on the actual plant and the tests of this project fall into this category, in the true sense of the macroscopic approach.

The geographical data for this test facility (Lethabo Power Station) are the following:

Longitude:	27° 58' 34,5" (South)
Latitude:	26° 44' 23,5" (East)
Altitude:	1459,7 m.a.s.l.
Gravity:	9,78665 ms ⁻²

For practical, financial and strategic reasons, unit 1 was selected for this test. The selection was dictated by factors such as the state of plant and the availability of the units, the Lethabo maintenance outage program, the ability to run at various loads, with agreement from National Control and measuring facilities that differ on the various units. The test results achieved with unit 1 were expected to be the most representative since this unit is the oldest at Lethabo with the most running hours, most modifications implemented, most seasoned ball charges in the mills, etc.

Table 3.1: UNIT ATTRIBUTES FOR TESTING PURPOSES

ASPECT	UNIT: 1 2 3 4 5 6
Calibrated feed flow orifice plate installed	x x
Machined ports to accommodate CO monitors	x x x
Opacity monitor ports per casing	x x
A/HTR gas outlet sampling ports per casing	x x x x
Coal feeder sampling ports	x x x x
NO _x /SO ₂ stack monitoring facility	x x x
Burner pipe sampling ports	x x
Balanced furnace characteristics	x x x
Lean coal test performed	x
Furnace characterisation test performed	x
EID excess air tests performed	x
Boiler guarantee efficiency test performed	x
Air flow Optimisation tests performed	x
Precipitator efficiency test performed	x x x
Opacity Monitor correlation test performed	x x x x x x

Plant constraints (such as the generator vibration problem that plagued unit 1 and limited the load to 400 MW, but which were cured during March 1993), was the main reason why the previous air flow optimisation tests had to be performed on unit 2 in September 1992 (Storm⁽²⁾). The unit preferred for testing then and now remains unit

1. It has the most measuring and testing equipment installed, since all other previous test work (Lean coal test⁽³⁾, Guarantee efficiency test⁽⁴⁾, etc.) was performed on it (see table 3.1). An interim refurbishment (IR) was performed on unit 1 from the 18th February to 20th March 1994. During April 1994 optimisation activities on this unit took place in preparation for the tests which were conducted from the 2nd to 20th May 1994. These preparation activities will be discussed in more detail in chapter 4.

3.2 UNIT AND CYCLE DESCRIPTION

The Rankine cycle for the steam plant at Lethabo Power Station is shown plotted on a T-s diagram in Figure 3.1. It is a sub-critical (<22,1 MPa, Figure 3.1 no. 3 - 4), super-heat (Figure 3.1 no. 4 - 5), reheat cycle (Figure 3.1 no. 7 - 6), with extended regenerative feed heating (Figure 3.1 no. 10, 11 & 12). The HP (Figure 3.1 no. 10) and LP (Figure 3.1 no. 12) feed heaters are surface heat exchangers, whilst contact feed heating is simultaneously done in a deaerator (Figure 3.1 no. 11). Sub-critical implies the presence of a steam drum.

Steam expansion occurs in one HP (Figure 3.1 no. 5 - 7), one IP (Figure 3.1 no. 6 - 8) and two dual flow LP turbine cylinders (Figure 3.1 no. 8 - 9).

Figure 3.1: RANKINE CYCLE ON T-s DIAGRAM

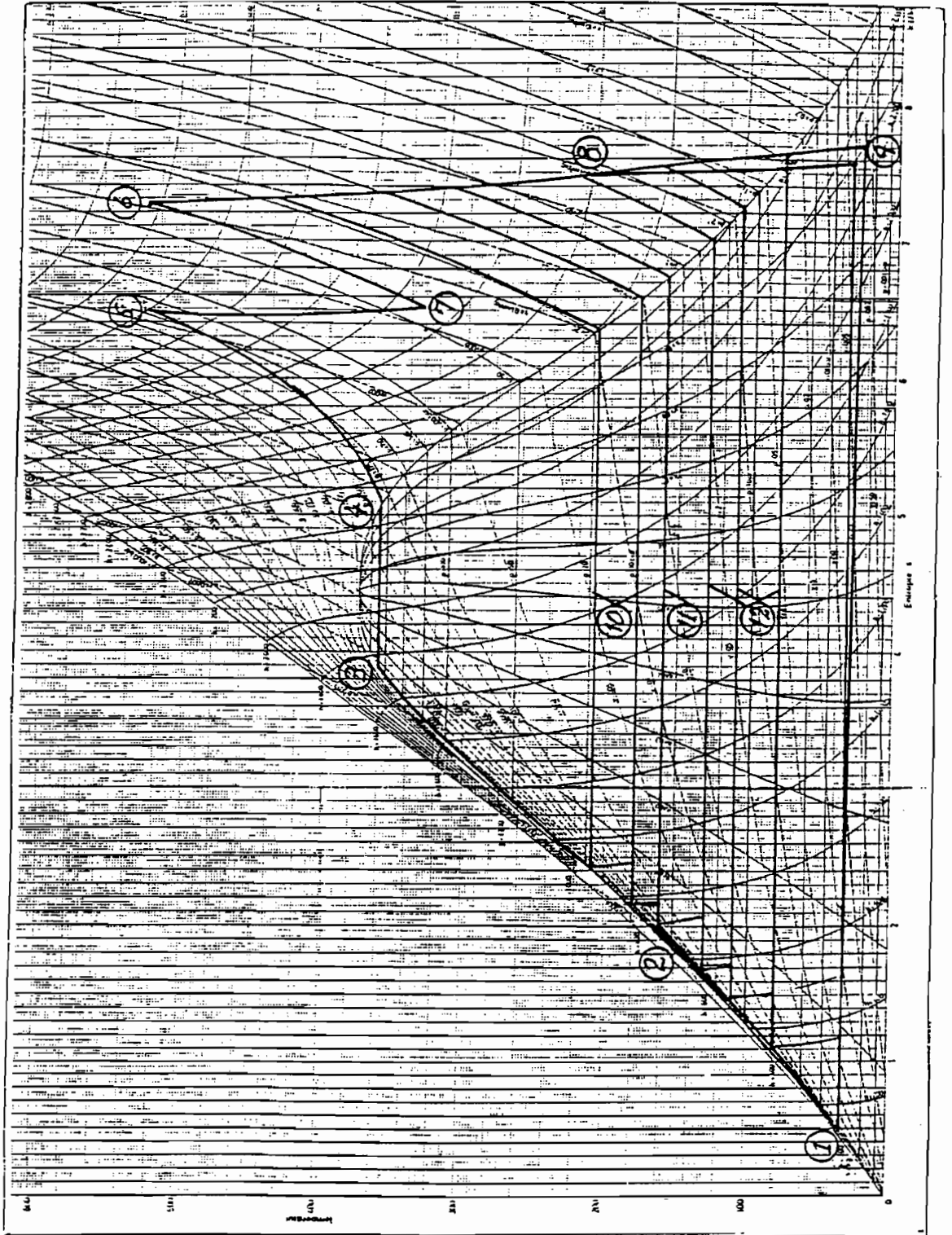

The latter exhaust directly into two condensers in tandem (Figure 3.1 no. 9 - 1) which operate at different temperatures due to the CW supply (11 m³/s) flowing through them in a series arrangement.

Feed pumping (± 500 kg/s) is in two stages (Figure 3.1 no. 1 & 2). The first stage (condensate extraction pumps) takes suction from the condenser hot well at an absolute pressure of ± 5 kPa and raises the pressure to 800 kPa and a gravitational head of 33m. The second stage (20 MW steam turbine driven 100% main pump, or two 50% electrically driven pumps) raises the pressure to overcome 64m of gravitational head and associated pipe friction to produce a drum pressure of 18,1 MPa.

The upper temperature of the working fluid in both live and reheat steam is controlled at 535 °C at all loads whilst the average MCR design temperature in the condensers is 35 °C. This renders the Carnot efficiency for this plant as:

$$\eta_{\text{Carnot}} = \frac{T_H - T_L}{T_H}$$

$$= \frac{(535 + 273) - (35 + 273)}{(535 + 273)}$$

$$= 61,88\%$$

This means that in the ideal case, considering the working fluid only, at least 38,12% of the heat must be rejected to the heat sink via the condensers and cooling towers. The design value of the turbine cycle heat rate (heat sink losses included) is a minimum of 8125 kJ/kWh at 618 MW generated (100% MCR). (See Figure 3.2.). This corresponds to a maximum efficiency of 44,31% for the energy conversion process in the turbine cylinders. The additional loss on the turbine plant due to auxiliary power for example, is another 2,74%, which reduces the useful total to 41,57%. The total boiler efficiency is approximately 89% which further reduces the overall value to 37%. This is the maximum possible cycle efficiency at optimum load.

The heat rate calculated from the inverse of this efficiency (9730 kJ/kWh) is called the optimum sent out heat rate. This is the minimum possible heat rate that the units at Lethabo can achieve at 100% MCR with specification coal to the boiler, freshly soot-blown, no ageing or deposits on turbine blades, etc. In practice, where the load factor over a month would average 80%, the coal quality is below specification and other parameters are below ideal design optimum, a typical Lethabo unit would achieve an overall efficiency of 35%.

A typical Sankey diagram for Lethabo (Figure 3.3) shows the losses as a percentage of primary energy input, including the heat that is

Figure 3.2: TURBINE HEAT RATE

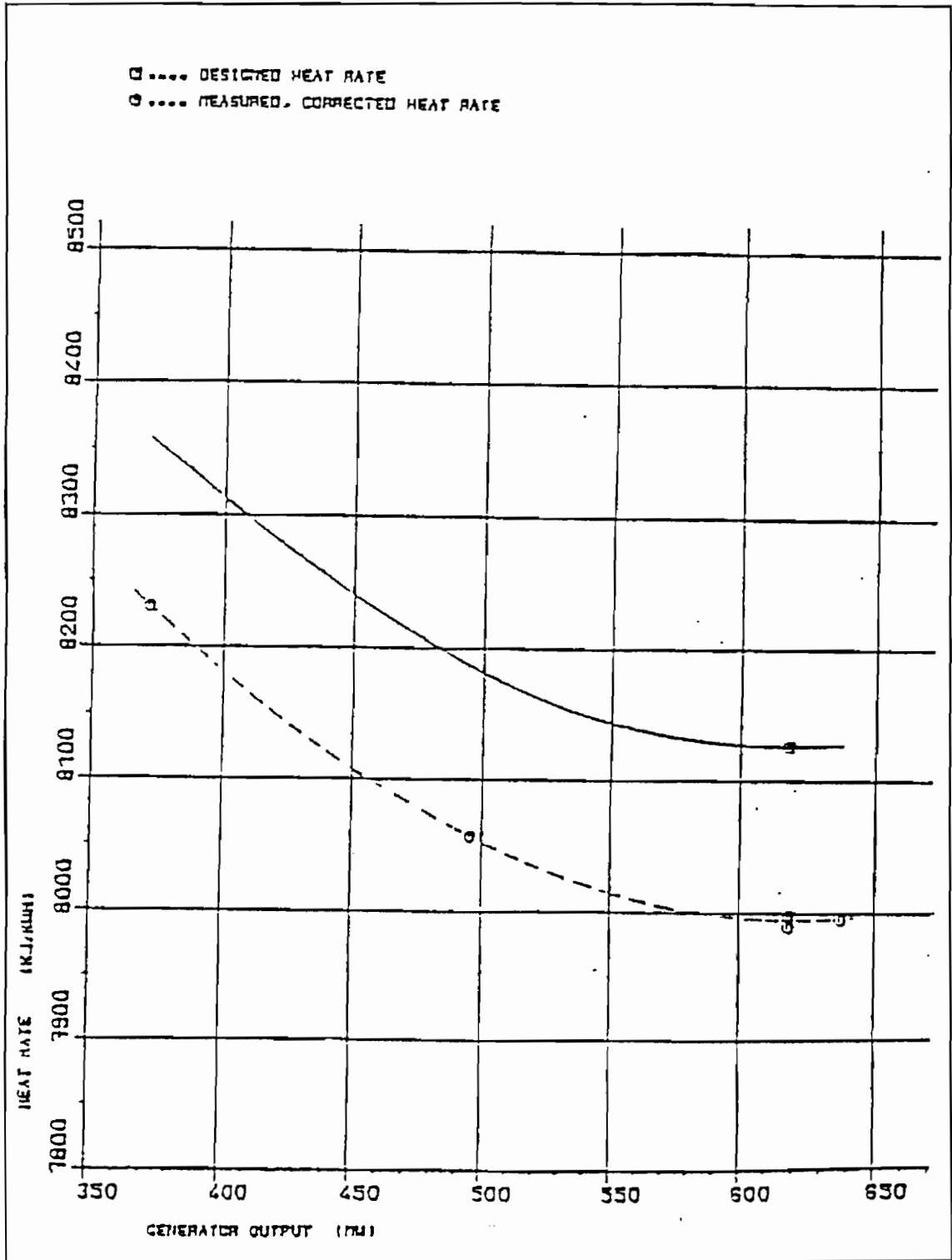
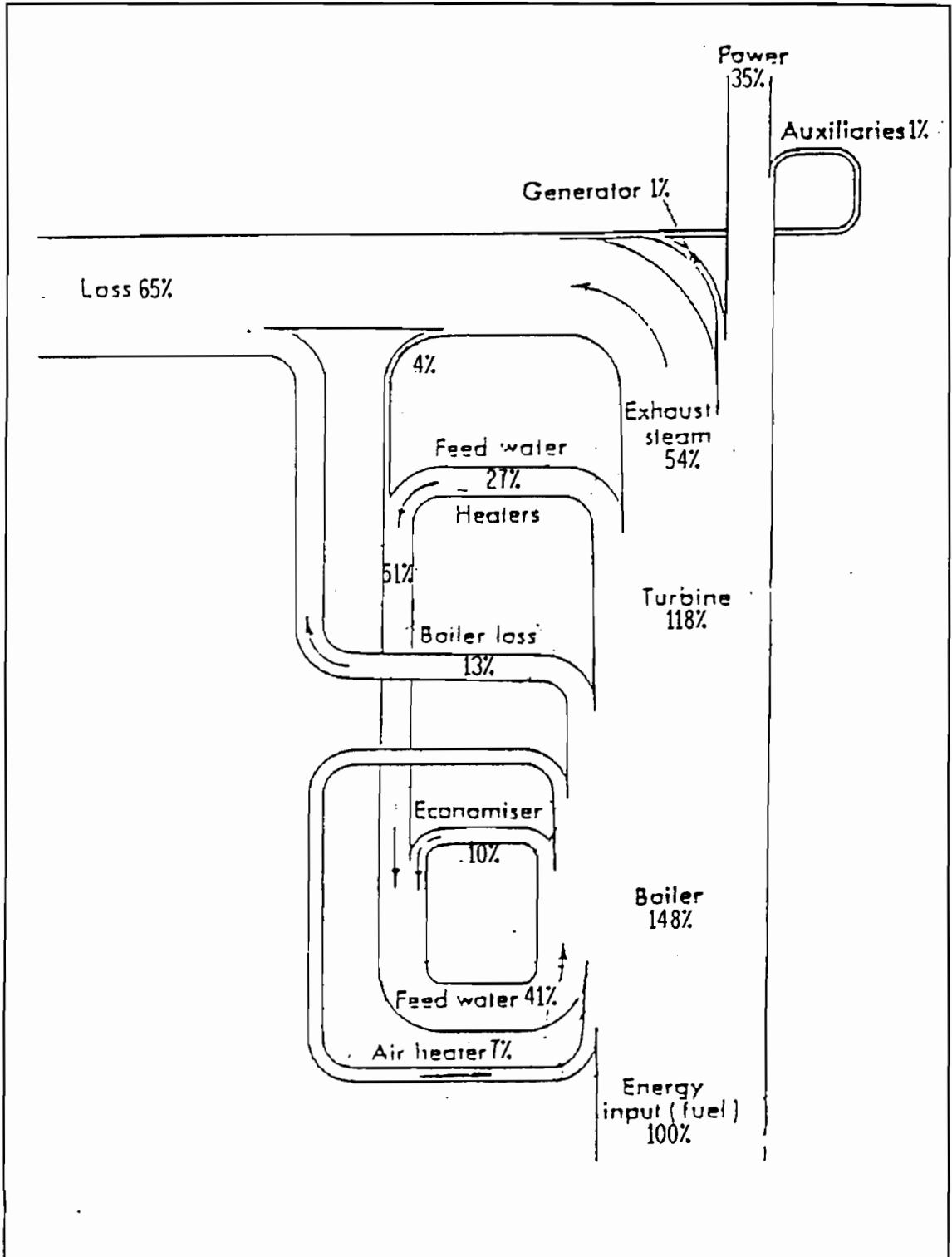

Figure 3.3: SANKEY DIAGRAM



recovered through regeneration (air and feed water heaters), the heat wasted to the heat sink and the final useful electrical energy sent out (to the national grid).

Concerning the overall efficiency of a unit (weighted average of simultaneous boiler and turbine operation) the maximum is assumed to be at 100% MCR. This will be evaluated in this test under the criterion of varying air flow and not varying design criteria.

The point of maximum efficiency for the boiler would be most affected by varying air flow and its influence on the load at which this maximum efficiency occurs.

3.3 TURBINE PLANT DESCRIPTION

The intention here is not to discuss the turbine plant in detail, but only those aspects that could influence the boiler and the unit as a whole with changing air flow to the combustion process. The fact that some of these aspects did present themselves during the unit 2 tests in 1992 (Storm⁽²⁾) makes an overview of this section of plant necessary. Excess air reduction caused the reheat steam temperature to decrease with a resulting decrease in final feed water temperature at lower loads. The influence of the turbine auxiliaries also proved to have a significant impact on the optimum efficiency point relative to combustion excess air quantity.

The physical aspects of the layout and components of the turbine plant were mentioned in section 3.2. Quantification thereof can be seen in Figures 3.4, 3.5 & 3.6. These flow diagrams display the sequential order of the working fluid through this part of the Rankine cycle:

- turbine cylinders
- condensers
- LP feed heaters
- HP feed heaters
- deaerator
- feed pumping stages

The magnitude of the physical properties of pressure (bar), temperature ($^{\circ}\text{C}$), mass flow (kg/s) and specific enthalpy (kJ/kg) are also given between each process. As mentioned, the turbine cycle achieves its maximum efficiency at 100% MCR as per design. There are some interesting aspects worthwhile mentioning since they can be influenced by certain variables of these tests (varying combustion air flow) and they can in turn impact on the boiler and overall efficiency. Emanating from experience in analysis and interpretation of STEP, as well as plant design factors, note the following:

- The cycle is more efficient with the SFP and BFPT in service than with the EFP's (see nomenclature). Depending on the load factor, this increase in efficiency can be up to 0,3 % for the entire cycle.

Figure 3.4: TURBINE CYCLE FLOW DIAGRAM - 100% LOAD

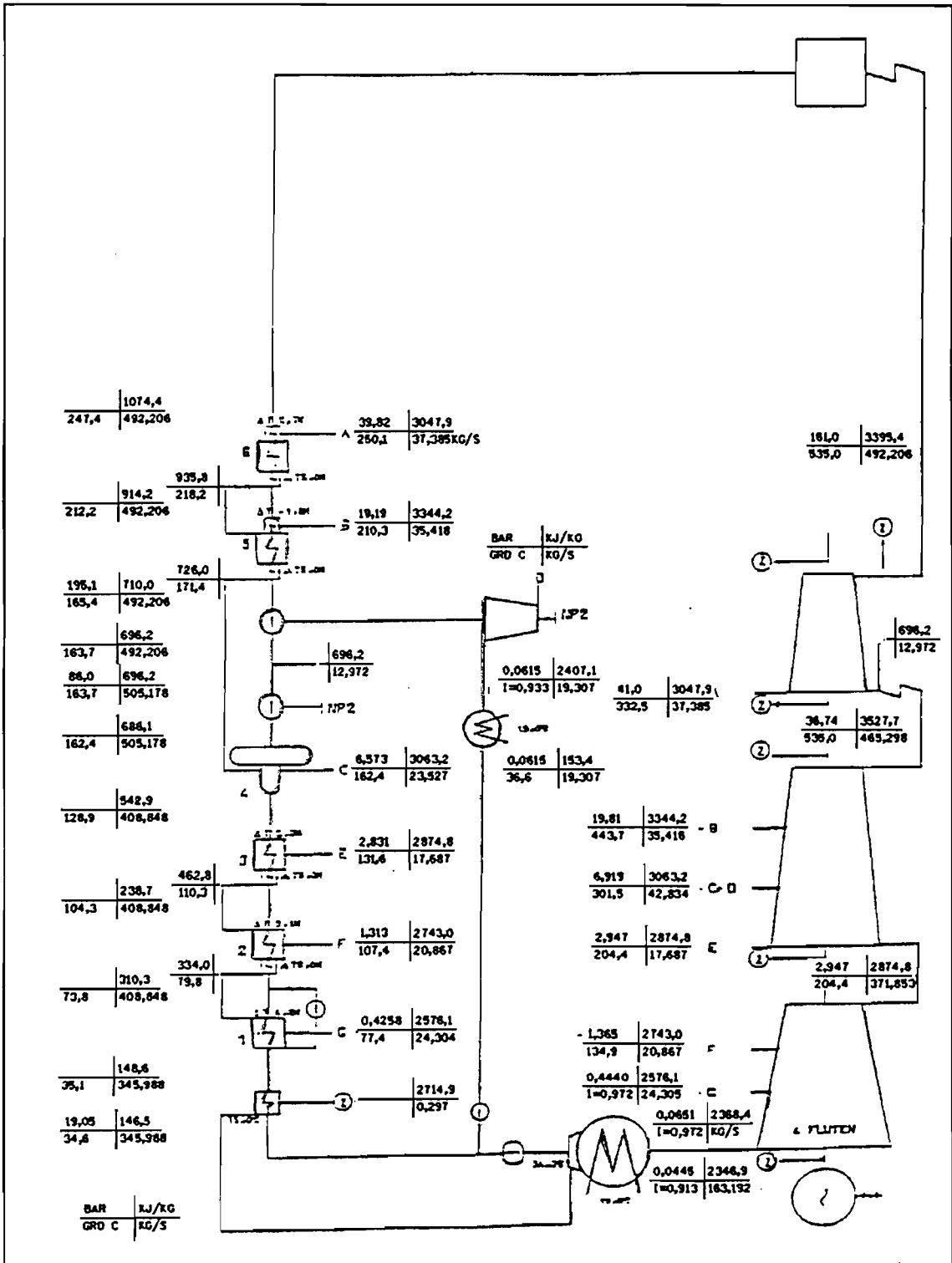

Figure 3.5: TURBINE CYCLE FLOW DIAGRAM - 80% LOAD

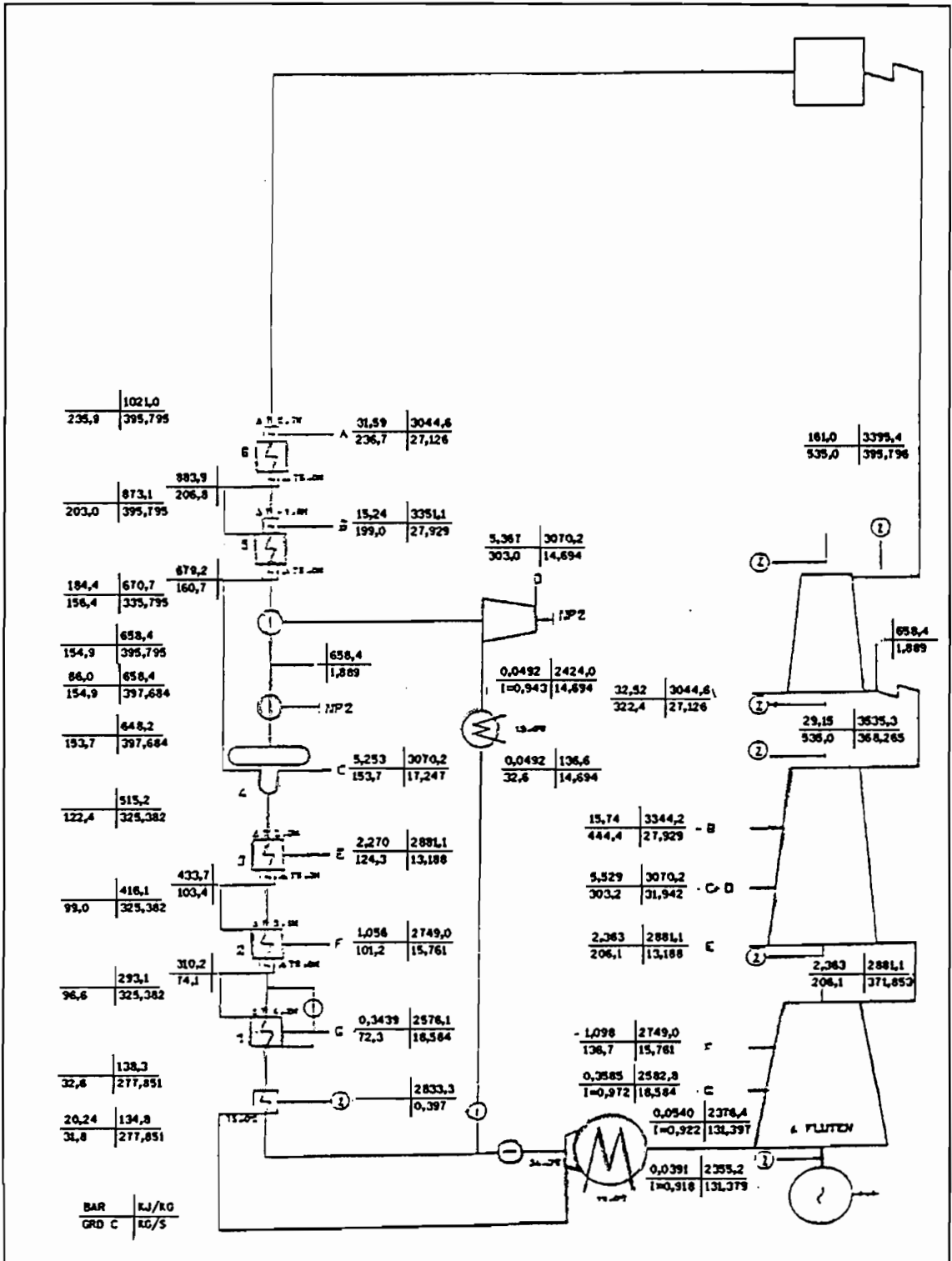
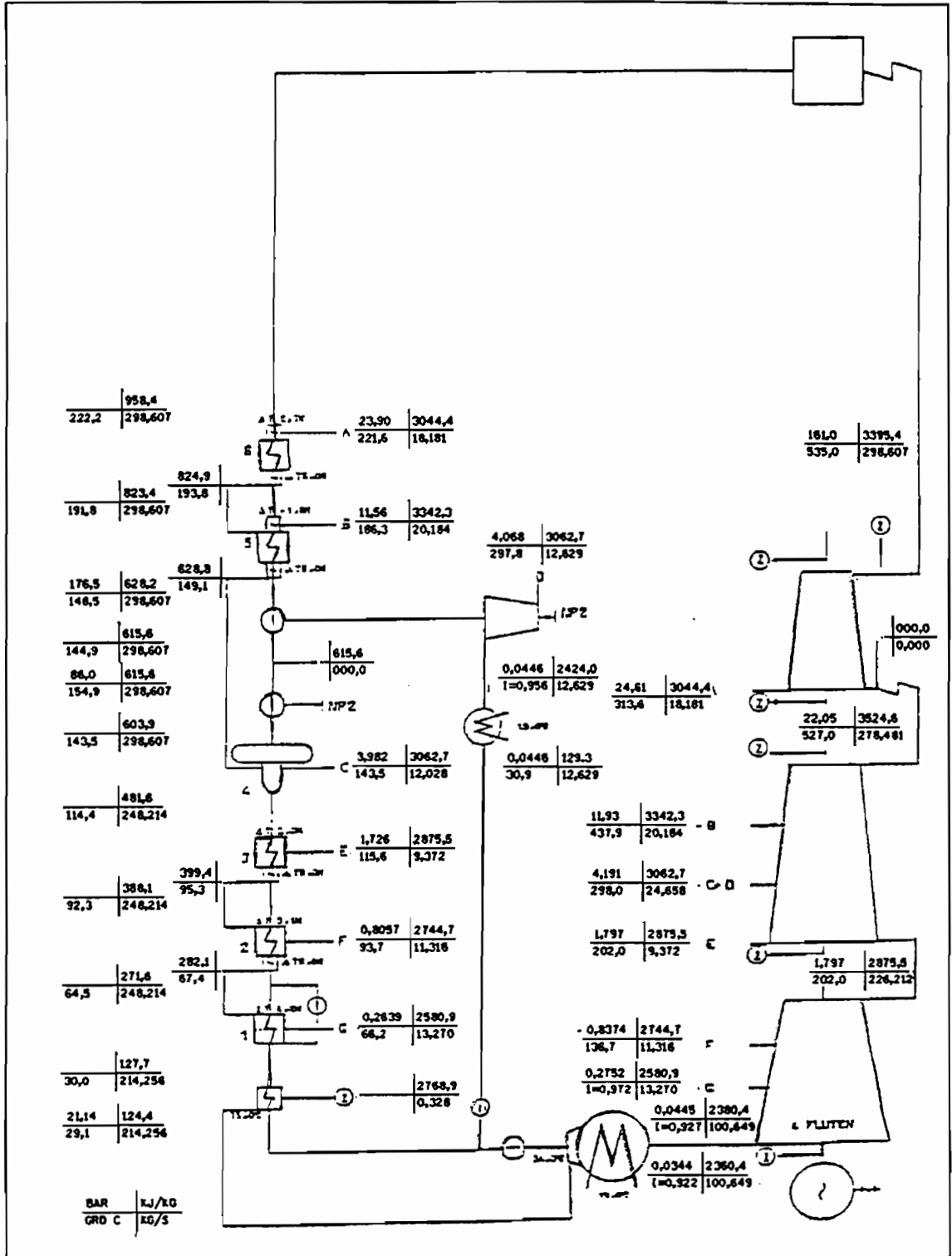

Figure 3.6: TURBINE CYCLE FLOW DIAGRAM - 60% LOAD



- Of all the losses, excluding overall governing factors such as load factor, there is not one that has such a significant impact on cycle efficiency as condenser performance. The cycle efficiency is very sensitive to condenser vacuum (back pressure).

- Numerically smaller than the condenser loss, but in the same order of magnitude, is the final feed water temperature. This is a measure of how effective the regenerative feed water system is and its effect on cycle efficiency. Important to note from Figures 3.4, 3.5 and 3.6 is that while the target final feed water temperature decreases with decreasing load, the bled steam percentages of total steam flow remains the same, regardless of the load.

The three above-mentioned aspects are important parameters where the turbine can impact on thermal efficiency and boiler combustion. For example, the boiler has to work harder for the same generator load if the EFP's are in service instead of the SFP. The test program had to avoid random changes of auxiliary plant in service between different tests, since consistency should prevail. Also, from previous test experience, it is important to note the amount of CW pumps in service as well as their configuration in terms of electrical power supply. This can impact greatly on efficiency via condenser vacuum and auxiliary power consumption since only certain CW pumps are supplied with power from unit 1 electrical boards.

3.4 BOILER PLANT DESCRIPTION

3.4.1 BOILER AND STEAM GENERATION

As mentioned, the Lethabo boiler is a sub-critical, water-tube evaporator accommodating a steam drum (Figures 3.7 & 3.8). On exiting the main feed pump at 22 MPa, 141 °C, HP feed heaters raise the temperature to 247 °C and the working fluid is further pre-heated in an economiser to 305 °C before entering the steam drum at 18,1 MPa, 357 °C. Natural circulation occurs due to density difference in the latent evaporation process via down-comers and side-wall manifolds, headers, risers and vestibule tubes.

There is no central dividing wall in the combustion chamber. Liquid and vapour separation takes place in the steam drum whereafter the working fluid passes on to the super-heating elements.

The flow path of super-heating commences with the primary super-heaters to 475 °C in the rear gas pass (Figure 3.11). The steam then reaches 500 °C through the platen super-heater panels, situated directly above the furnace, where it is exposed to the highest flue gas temperatures. Figure 3.9 shows the maze of pipe work of super-heating. Two aspects are worthwhile noticing here:

- Steam super-heating takes place in four banks from left to right, namely A, B, C, and D, when the boiler is viewed from the front.

Figure 3.7: WATER FLOW THROUGH BOILER

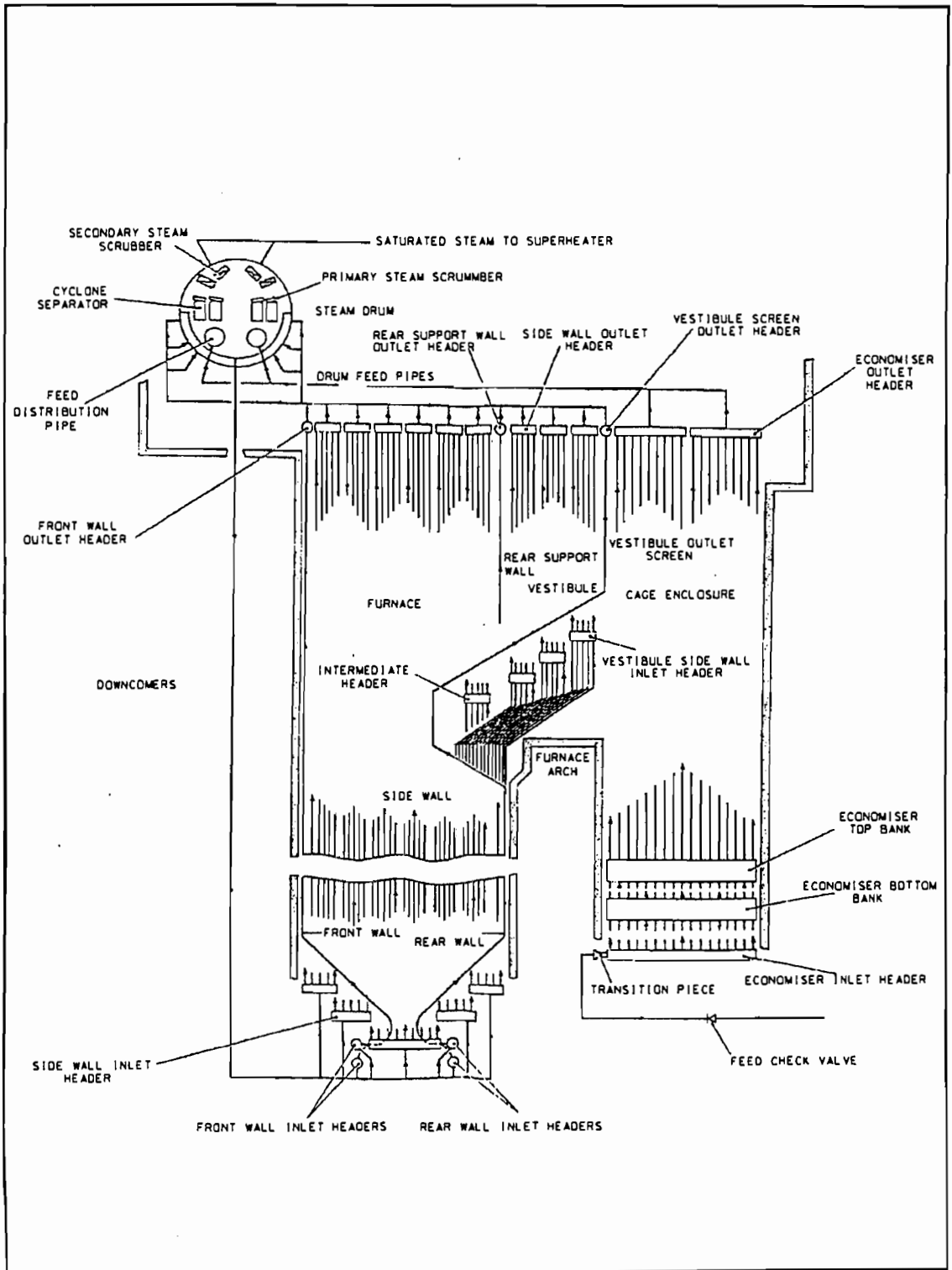

Figure 3.8: SECTIONAL VIEW OF STEAM DRUM

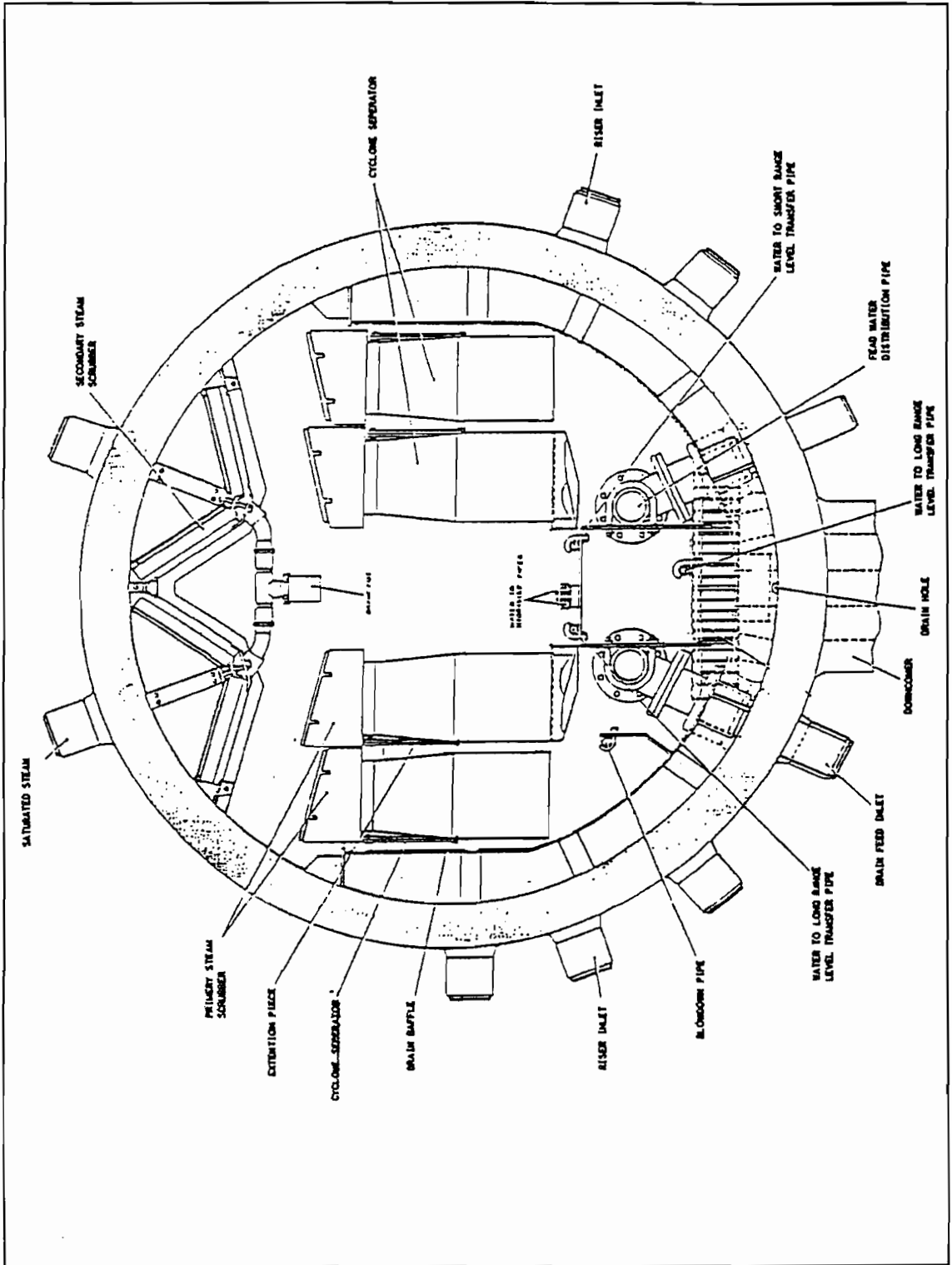
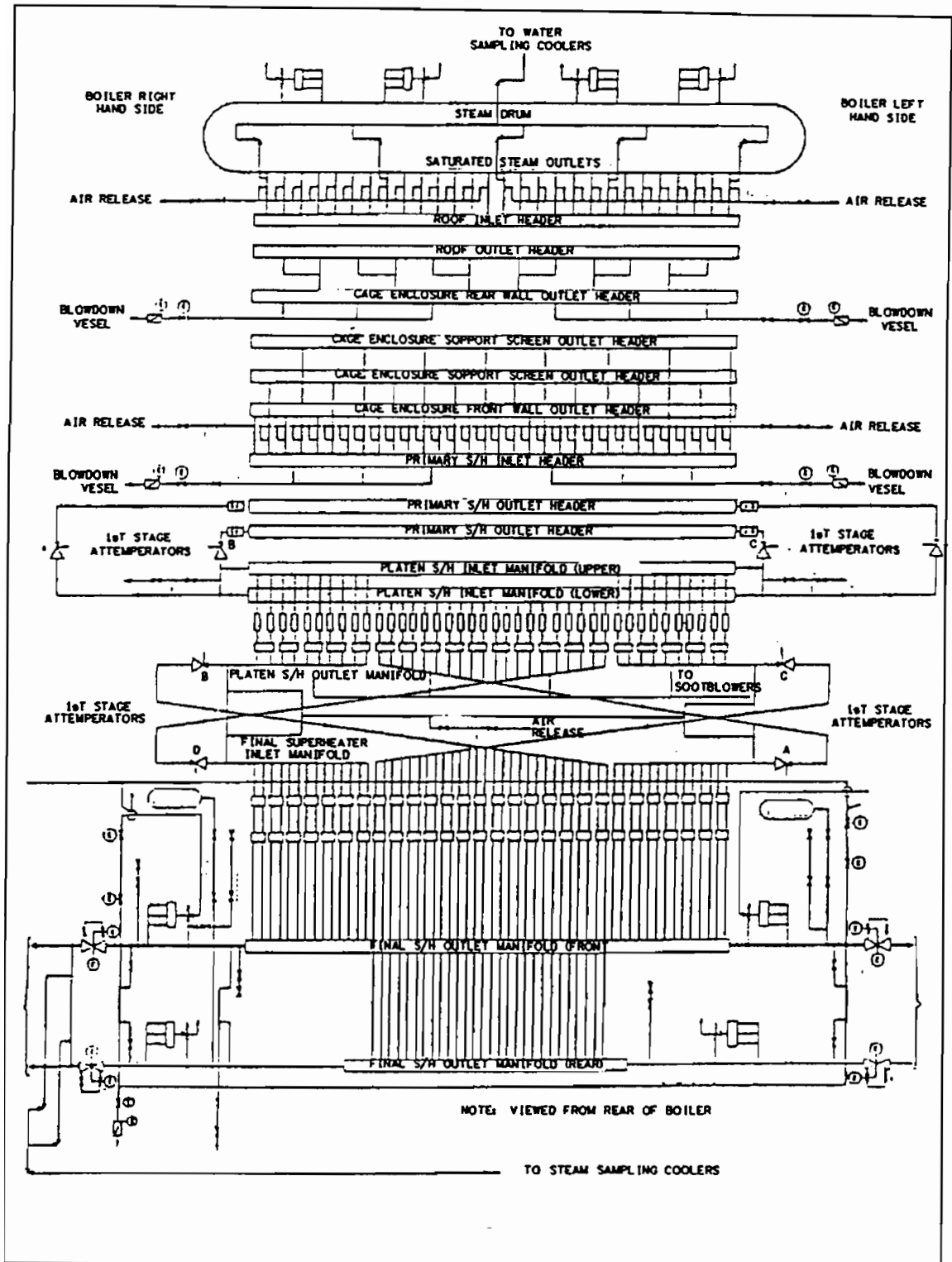

Figure 3.9: BOILER STEAM SIDE SUPER HEAT FLOW DIAGRAM



- The pipe work between these banks perform cross-over traversing between primary, final or secondary and platen super-heaters in order to eliminate any unbalance in the furnace and flue gas temperatures.

The first stage attemperating or spray water is added before entrance to the platen super-heaters. Four attemperation stations capable of 15 kg/s each are controlled by the platen super-heaters outlet temperature. The steam then enters the secondary or final super-heaters, also with four attemperation stations of 4 kg/s capacity each and controlled by the final boiler live steam outlet temperature of 540 °C. There is a 5 °C temperature loss to the turbine where the required design inlet conditions are 16,1 MPa, 535 °C. After the HP turbine the steam returns to the boiler (4,1 MPa, 332 °C) as cold reheat for reheating. The primary reheater raises the temperature to 460 °C and is situated in the rear gas pass. The final reheater is situated just behind the final super-heater in the front gas pass. A cross-over arrangement of pipe work between the four banks, similar to the superheater, also exists between reheater pipe work (Figure 3.10). The reheater has four attemperation stations capable of 11 kg/s each, controlling the final reheater steam temperature to 540 °C. The required hot reheat steam design conditions of 535 °C and 3,8 MPa then result at the IP turbine inlet.

Figure 3.10: BOILER STEAM SIDE REHEAT FLOW DIAGRAM

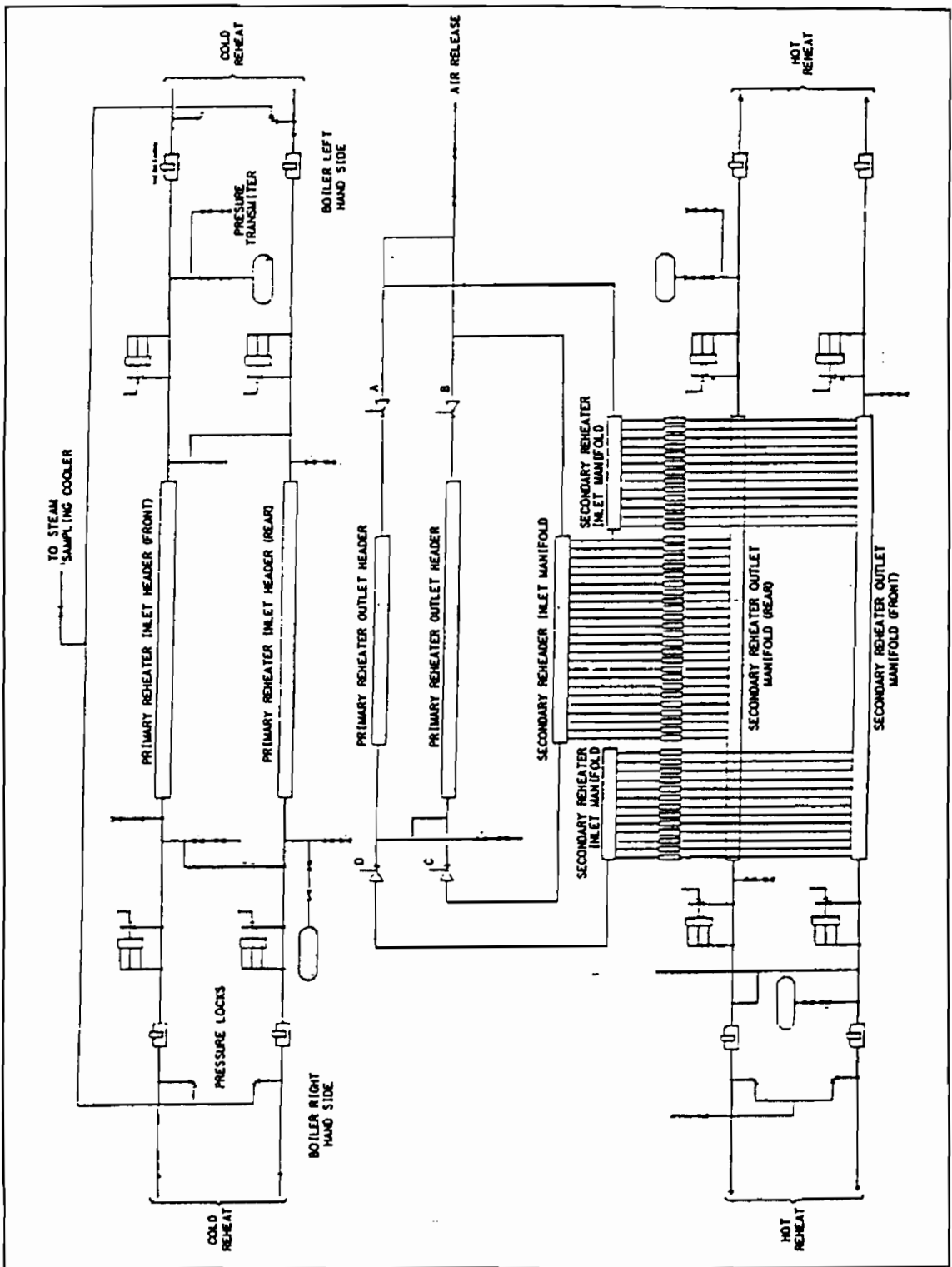

3.4.2 FURNACE AND COMBUSTION

The furnace is constructed such that the combustion process provides heat to the evaporation process primarily in the radiant mode (Figure 3.11). Combustion temperatures are between 1200 °C and 1400 °C. The platen super-heaters also receive some radiant heat but thereafter the heat transfer occurs mostly via convection, with conduction once the heat reaches the metal of the tubes. The front and rear gas passes are constructed in such a way that the heat transfer between flue gas and steam occurs in the counter flow arrangement.

After passing over the furnace, platen, final super-heater and final reheater tubes, the gas (± 700 kg/s) has cooled down to ± 600 °C. It then passes through the rear gas pass in a downward direction through the primary super-heater, primary reheater and economiser to exit at a temperature of ± 320 °C. The maximum gas velocity of ± 10 m/s occurs at the top of the front gas pass before entering the rear gas pass. Depending on the load, an air molecule or pf particle takes 7 to 12 seconds to travel between burner and economiser exit.

Downstream of the economiser, the gas duct splits into two. The gas in each of these ducts then passes through a primary and a secondary air heater in parallel, to cool down to ± 130 °C. Thereafter each duct splits into two to enter the four electrostatic precipitator casings. After passing through the precipitator, where more than 99,9 % of the fly ash is removed, the four ducts join into

Figure 3.11: DIAGRAMMATIC FURNACE ARRANGEMENT

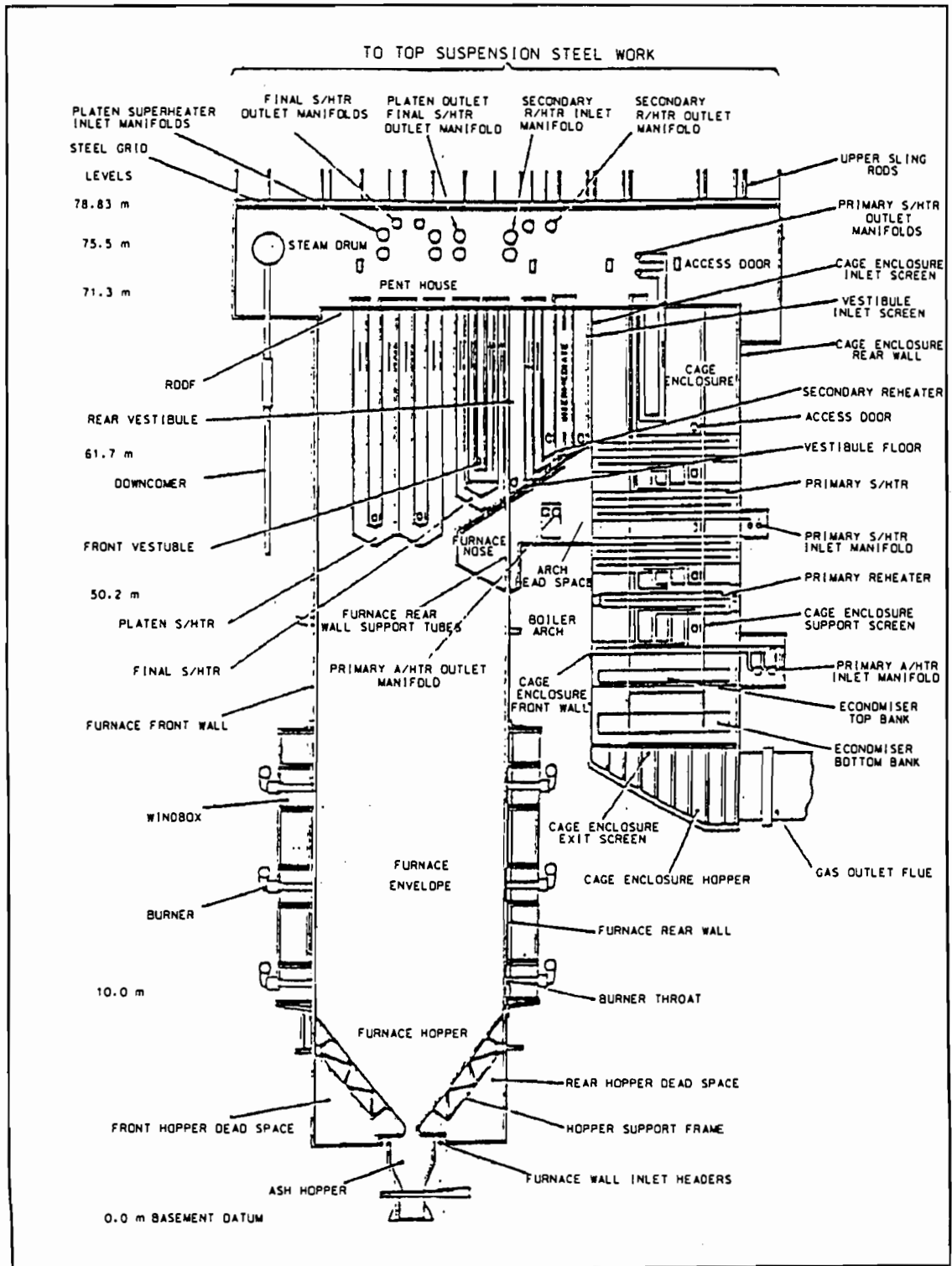

two separate ducts where two ID fans (\pm 3,5 MW each) take suction to propel the gas to atmosphere via one flue that passes up the multi-flue chimney stack (275 m high).

Two FD fans situated at ground level, take suction inside the boiler house at 73m level to utilise the radiant heat loss from the boiler and furnace (Figure 3.12) where the ambient temperature ranges from 25 °C (winter) to 40 °C (summer). The capital outlay of this arrangement, extra ducting for example, is overridden by the gain in efficiency and air heater protection. It can be detrimental to metal surfaces if the cold air side temperature of the air heater is not kept above dew point since sulphuric and other acids in the flue gas originating from the combustion process are extremely corrosive. The aerofoils measuring total air (sample calculation 2) are situated in the FD fan intake ducts at 41m level.

The air then passes through the secondary air heaters where its temperature is raised to approximately 260 °C before entering the furnace via the burner. The secondary air flow control to the furnace is through thirty six SA aerofoils and dampers (one per burner). The total arrangement of SA flow can be seen in Figure 3.12.

Two smaller primary air fans take suction in parallel with and from the same duct as the FD fans and supplies the mills via the primary air heaters, with air at a temperature of 260 °C (Figure 3.13).

Figure 3.12: SECONDARY AIR FLOW DIAGRAM

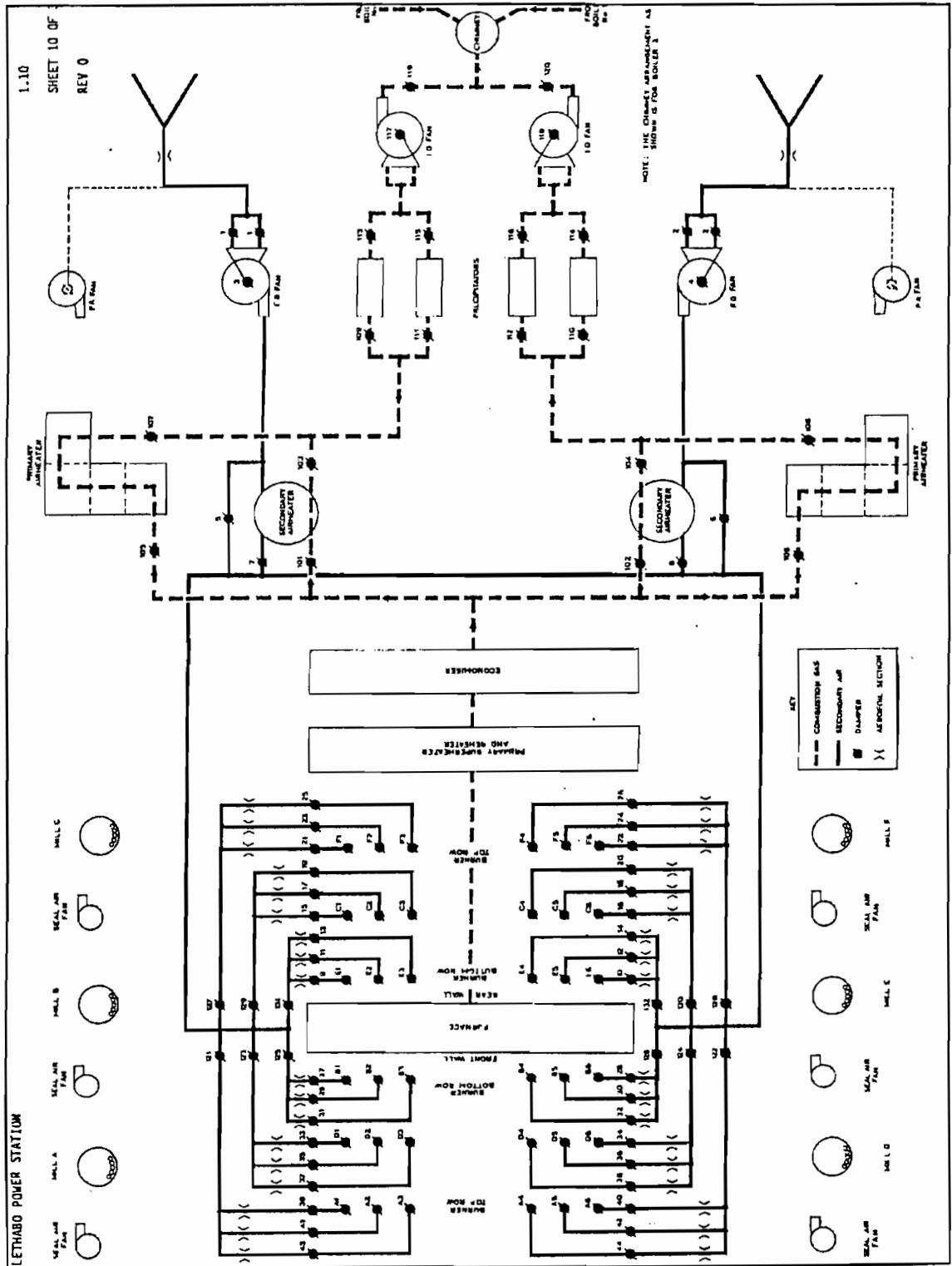
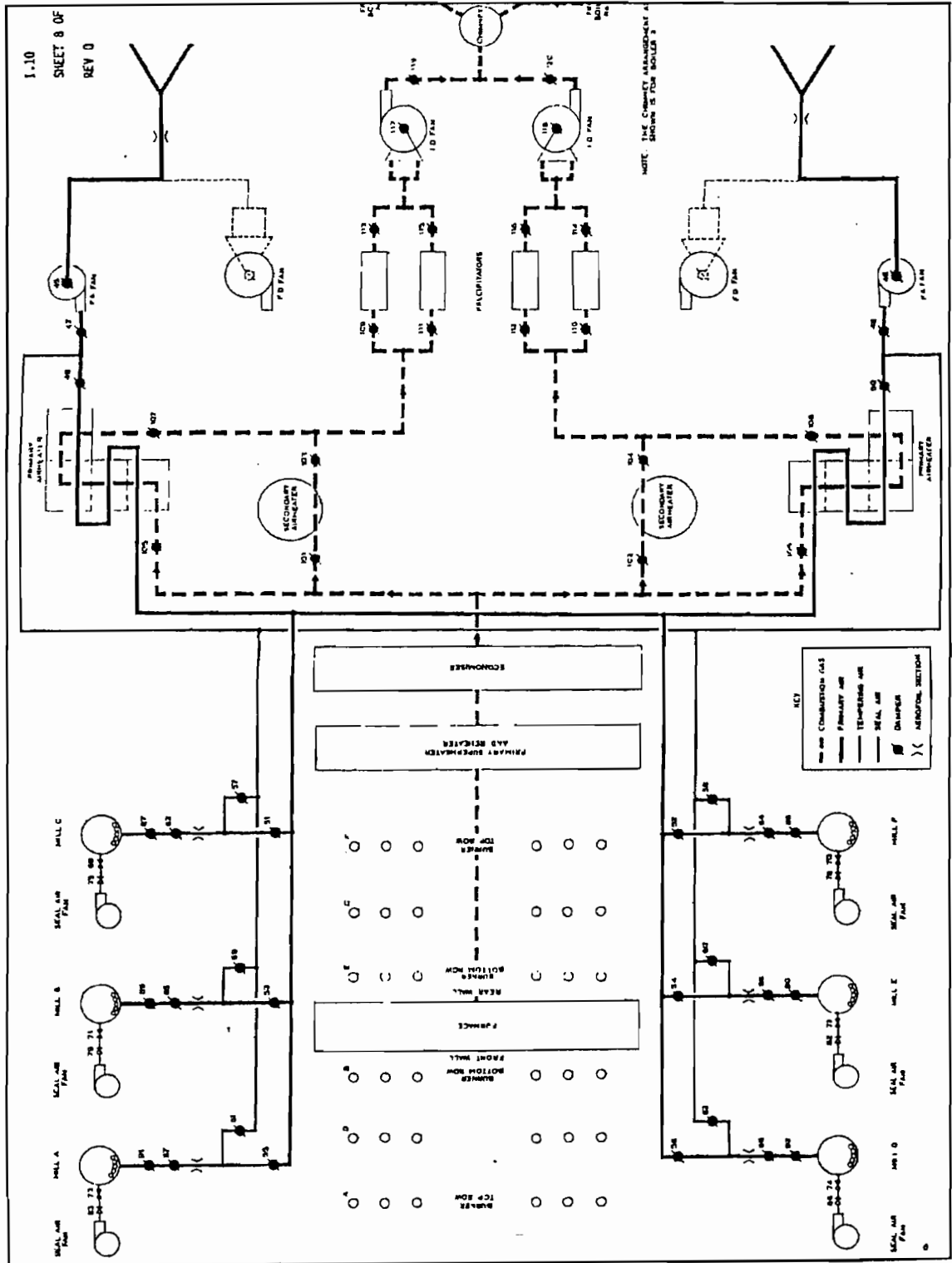

Figure 3.13: PRIMARY AIR FLOW DIAGRAM



To prevent a fire from developing in the mills due to excessively hot primary air, an attemperating facility is provided to cool the air entering the mill with air bypassing the P/A/HTR. To prevent the leakage of pf from the pressurised mill, a seal air system, powered by seal air fans discharging at a pressure greater than that of the PA fans, seals off the trunnions and volumetric feeders. The latter and the entire interrelated PA system can be seen in Figure 3.13.

Each boiler has six mills. Full load can be maintained with five while the remaining is on stand-by or available for maintenance. The mills are situated on ground level and supply the furnace with PA and pf via burner pipes in an arrangement as in Figure 3.14 and 3.15. Each mill has two bunkers, each fitted with a volumetric coal feeder. The coal and PA to each mill is thus supplied in dual flow mode and the resulting PA/pf mixture also leaves the mill in dual flow via two classifiers. The classifier (Figure 3.16) is a constant efficiency device that segregates the percentage of oversize coarse material from the mixture and recirculates it back to the mill. The temperature of the PA/pf mixture leaving the classifier reduces to 80 °C due to the sensible heat absorbed by the coal and latent heat needed to evaporate the inherent and surface moisture during the grinding process.

The mills are of the tubular type each driven by a 1600 kW electric motor. Each mill contains 98 tons of grinding media which consists of 50 mm diameter steel balls having 12% Cr. This type of mill absorbs

Figure 3.14: MILL AND BURNER PIPE ARRANGEMENT

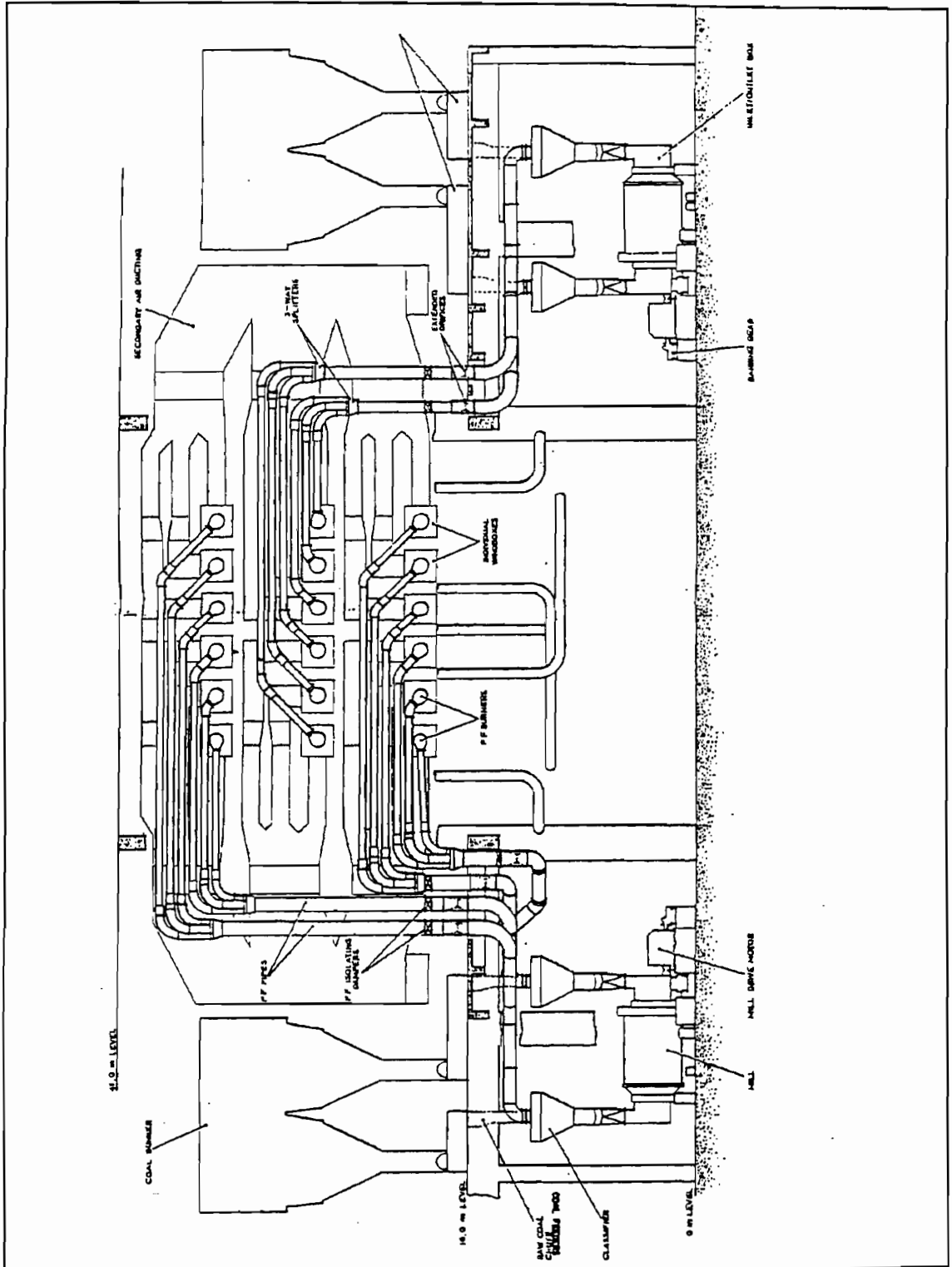

Figure 3.15: MILLING PLANT ARRANGEMENT

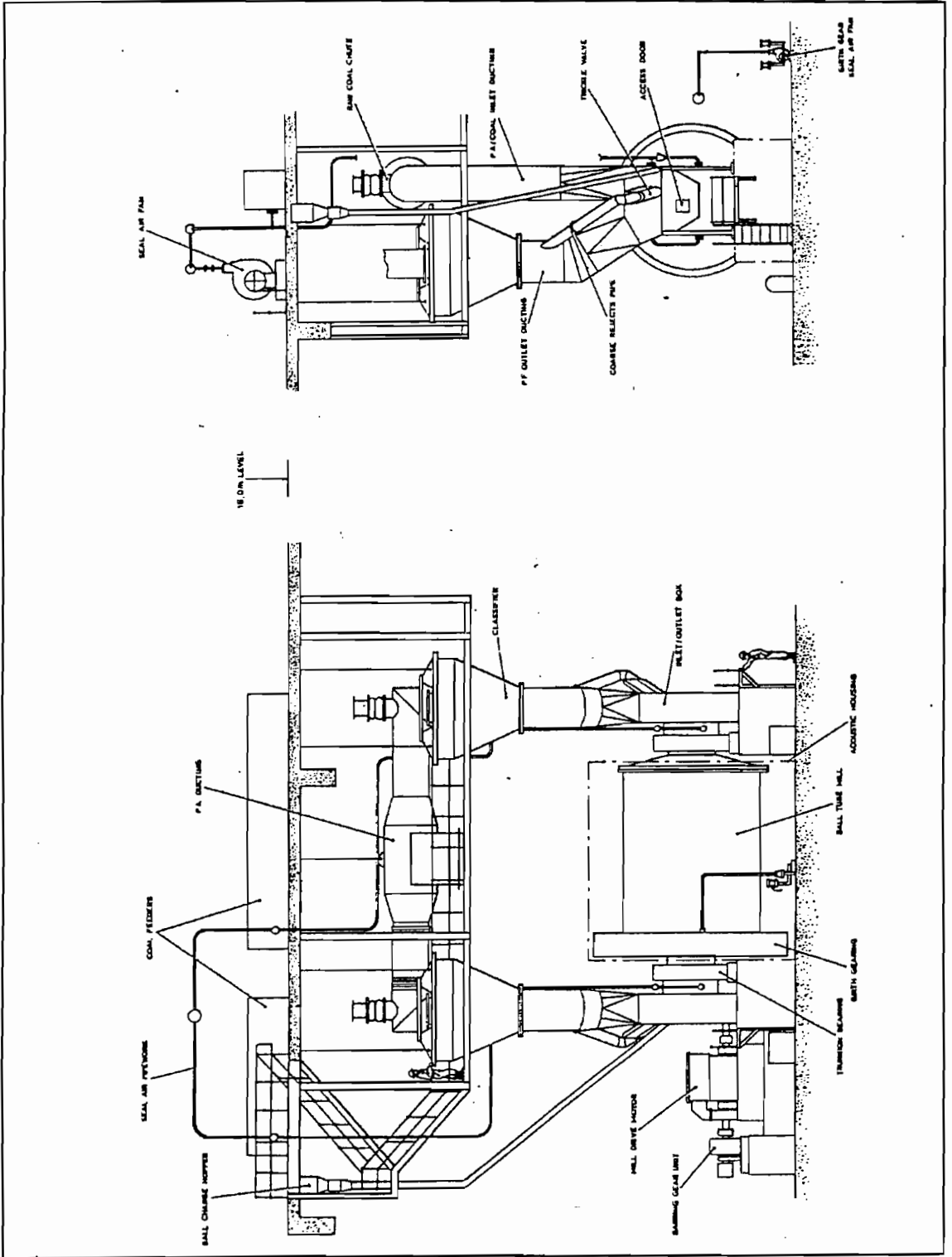
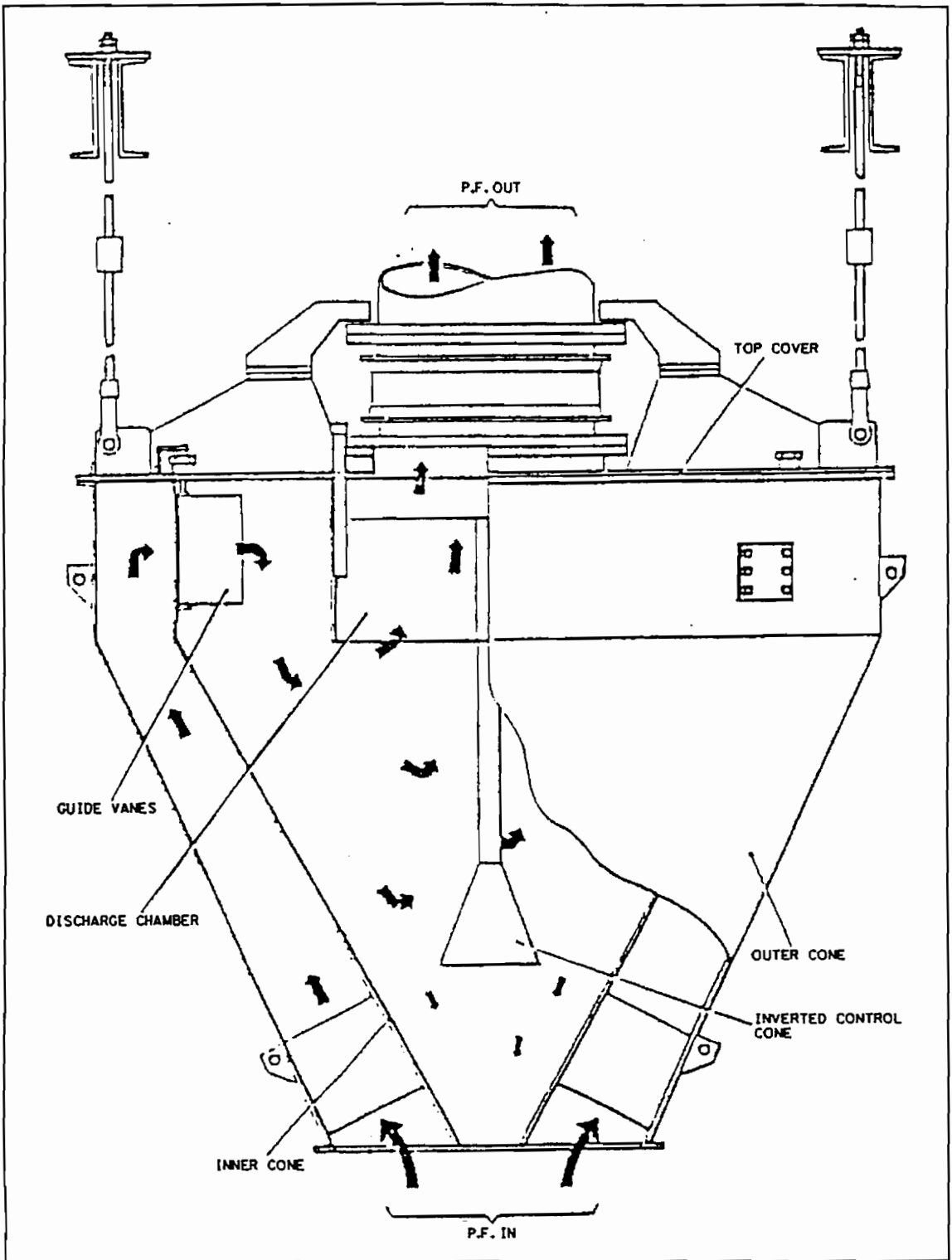

Figure 3.16: MILL CLASSIFIER



virtually constant motor power once the charge has been established, irrespective of load and throughput (± 80 tons/hour coal flow / mill).

The mill is a very important component in combustion testing. If the trunnion division plates (dividing the incoming PA and coal from the outgoing PA/pf) are damaged or are not in the required symmetrical position, the combustion conditions within the furnace can become unbalanced. Similarly, if the mill controls are not functioning correctly, this can render it impossible for the boiler to stabilise and to produce the required test conditions. The procedure to calibrate the mill so that its physical properties such as the mass of the ball charge and the required amount of coal fed into the mill at a particular time, correspond to the required power and feeder control set points, is called a stripping and filling peak procedure. This procedure must be performed at regular intervals since the ball charge wears away and the make-up must be determined. This procedure will be discussed in chapter 4.

Each end of the mill supplies three burner pipes via the classifiers and each enters the furnace through a burner (Figure 3.17). Thus, each mill supplies a row of six burners while each boiler has thirty six burners, 18 in each of the opposing front and rear furnace walls. The oil lance for starting a mill is in the centre of the burner, while the PA/pf tube and SA are located concentrically around it.

Figure 3.17: PF BURNER

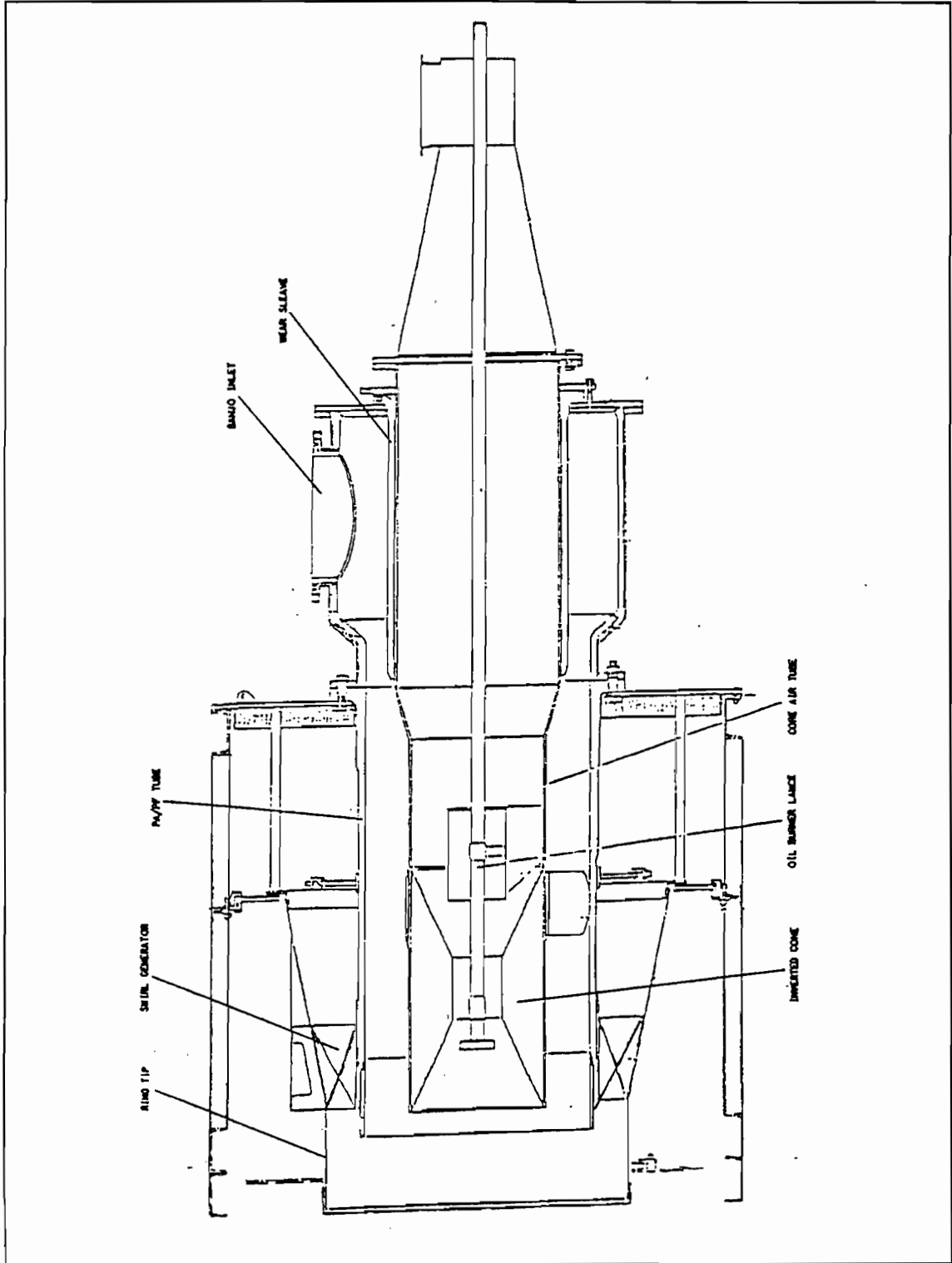

The burner is one of the most important components in this test project since a heat-distorted or otherwise damaged burner can produce an abnormal amount of CO due to incomplete combustion. Incorrectly and inconsistently set burner swirl generators can cause the same. Unbalanced combustion conditions makes testing conditions more difficult.

The tubular primary and regenerative secondary air heaters are also very important components of plant. They impact significantly on efficiency and also have a great effect on the rate of ignition since the increase in ignition temperature has an exponential growth with distance from the burner. If the temperature is too low ignition and combustion can be prolonged to such an extent that an increase in temperature of the super-heater metal elements occur.

The secondary air heaters are of the rotating type Lungström design utilising rotating element packs and weigh 140 tons apiece (Figure 3.18). The relative movement due to rotation makes the use of axial, tangential and radial seals necessary (Figure 3.19). Axial seals prevent air to gas leakage and are automatically controlled by actuator motors sensing and correcting the gap distance. Tangential seals prevent gas to gas and air to air leakage. They have a fixed cold setting and have no sensors and actuators. Radial seals also limit air to gas leakage and are controlled by gap sensors. These are the most important seals since most leakage occurs via them.

Figure 3.18: SECONDARY AIR HEATER

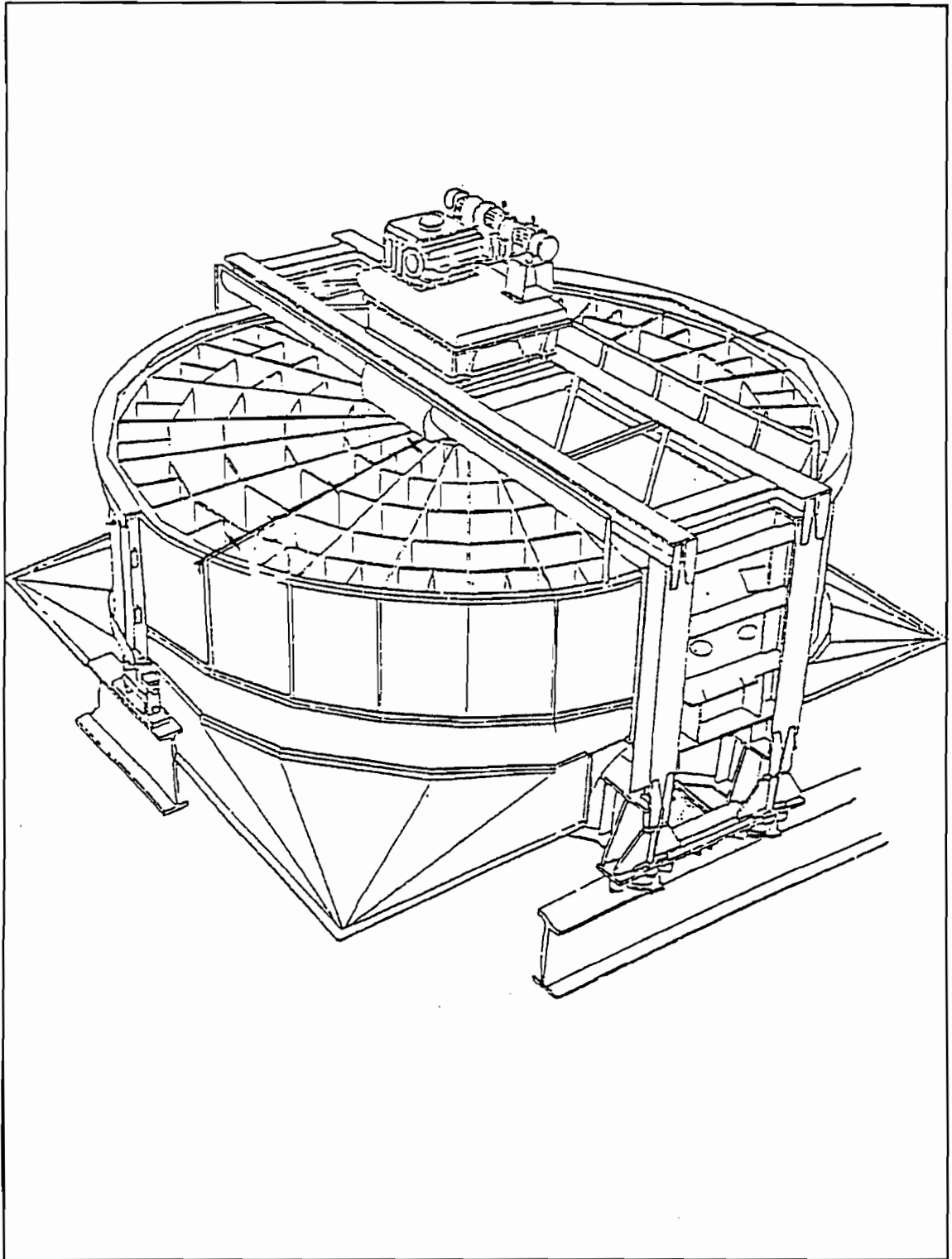
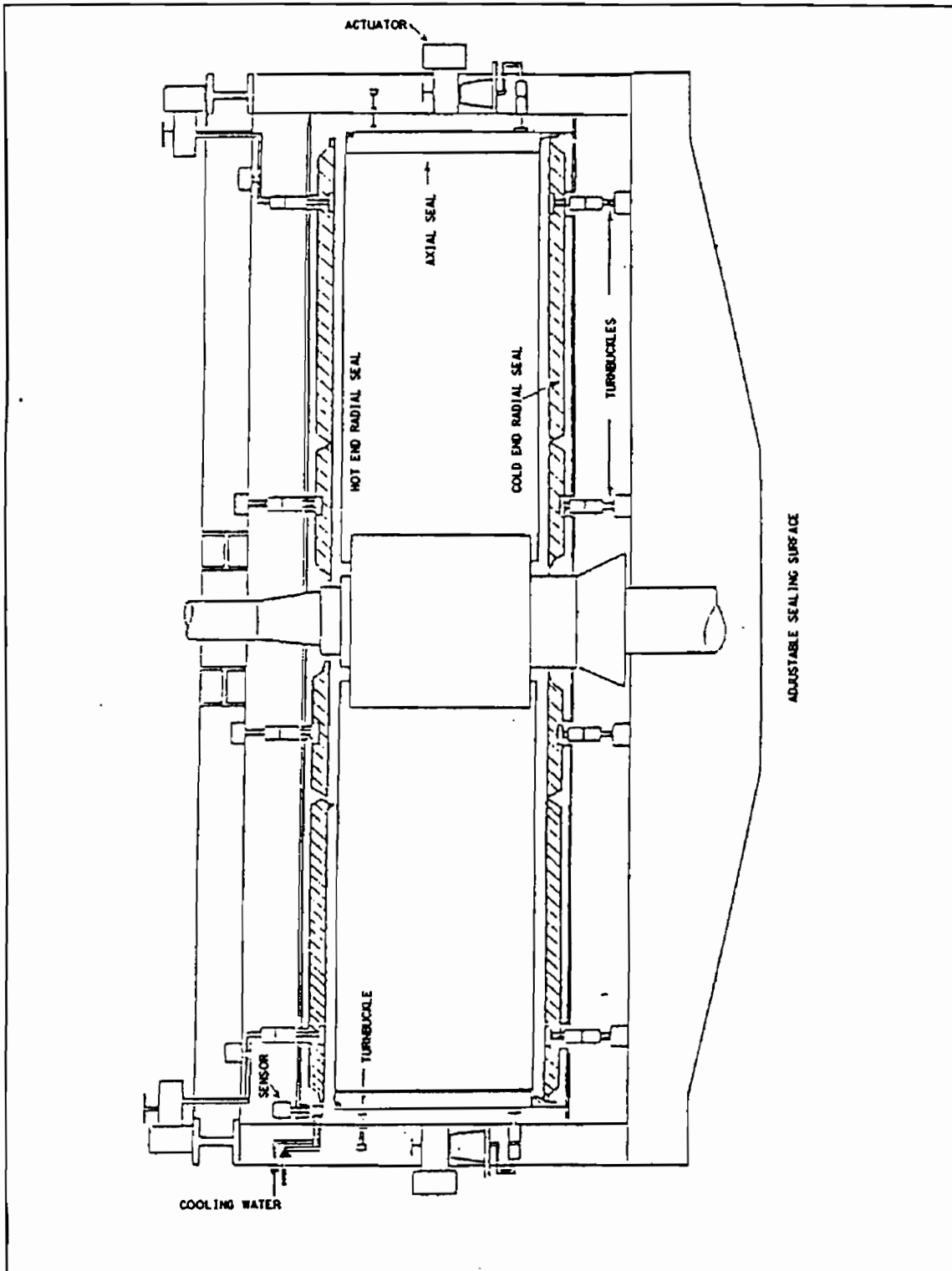

Figure 3.19: SECONDARY AIR HEATER SEALS



The primary air heaters are of the tubular type operating in counter flow heat exchange mode. There are two passes of gas flow and four passes of air cross flow (Figure 3.20). Leakage can also occur from air to gas in the P/A/HTR if tubes carrying the gas come adrift from the tube end plates. In the event of these air heaters being deficient, e.g. blocked with ash or excessive leakage, reduced thermal efficiency and delayed ignition and combustion will result. In addition a false impression of favourable dry flue gas loss is created. The latter is very important to this type of testing since it played a significant role in the EID tests⁽⁵⁾ mentioned previously. It is to eliminate this defect and to correct the leakage dilution on the dry flue gas temperature (see sample calculation 3) that the measuring of oxygen before as well as after the air heater was introduced in this project.

The boiler soot blowers merit mentioning since they influence boiler efficiency. A dirty furnace and associated heat transfer elements will have a negative effect on the rate of heat transfer resulting in an increase in dry flue gas loss. Heat input into different sections of the boiler will also be affected.

A Lethabo boiler has a total of 128 soot blowers (see Figure 3.21). They consist of four secondary air heater blowers, thirty two furnace wall blowers of the short stroke fixed rotating type, whereas all other blowers are of the retracting long lance type, twenty four for

Figure 3.20: PRIMARY AIR HEATER

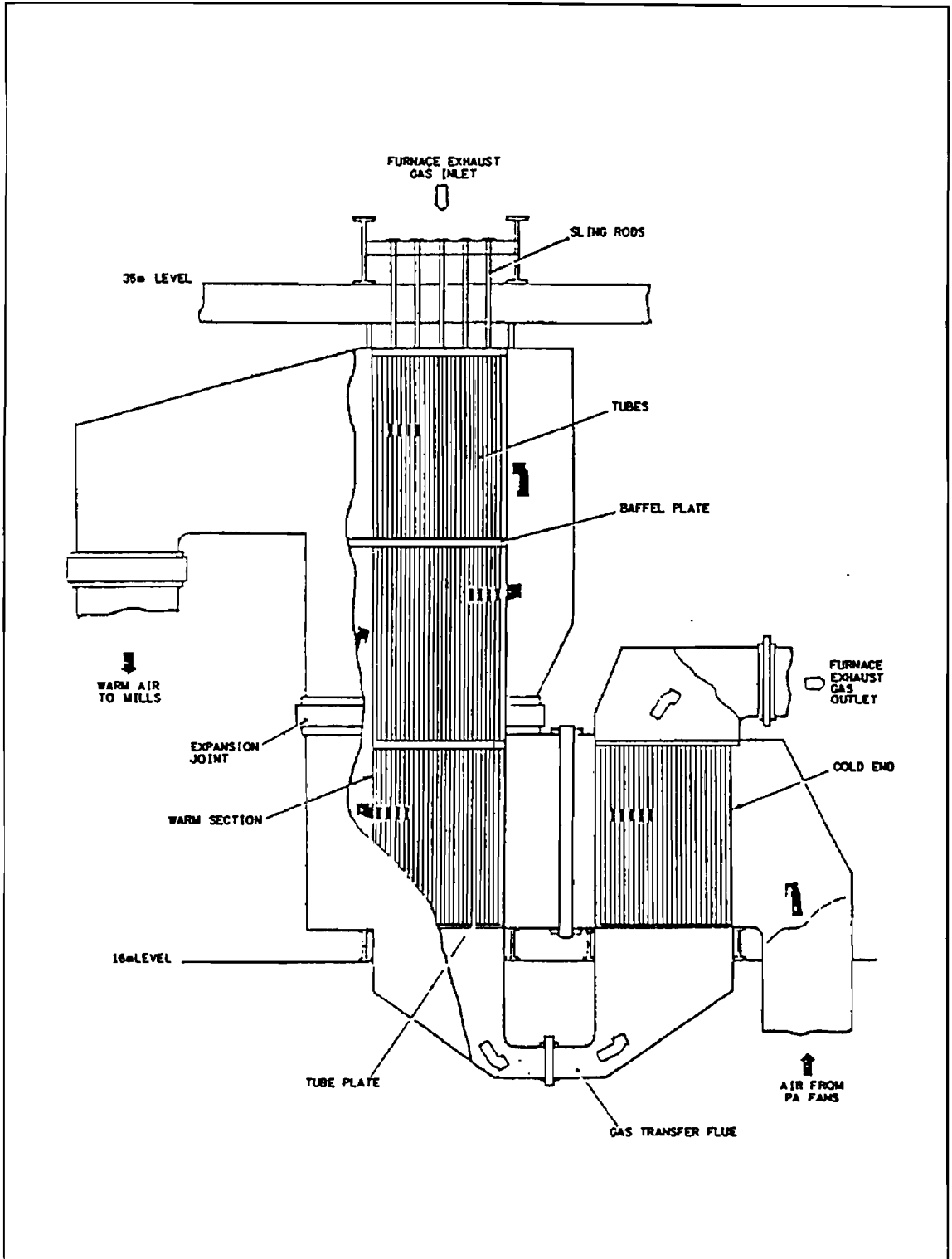
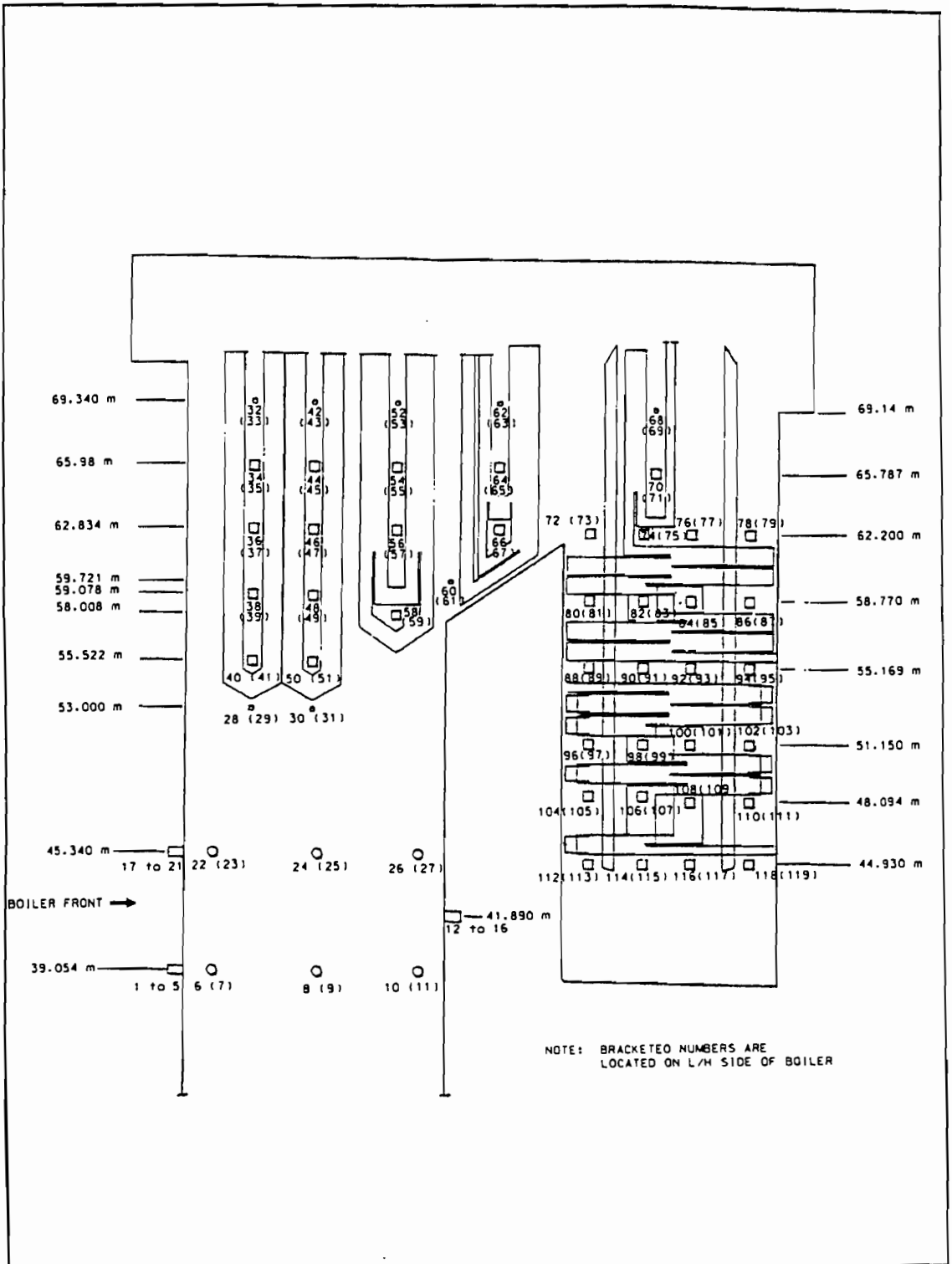

Figure 3.21: SOOT BLOWER LOCATION DIAGRAM



the platen super heater, eight final super-heater and eight reheater blowers in the front gas pass. The remaining fifty two blowers are situated in the rear gas pass and serve the primary super-heater, primary reheater and economiser.

At Lethabo many arguments evolved around the influence of soot blowing on boiler efficiency, super-heater metal temperature excursions and plant deficiencies, and several enhancement programs were conducted. Secondary air heater blockages for example, were shown to be caused by the malfunctioning of the air heater soot blowers depositing moisture into the packs and clogging the ash⁽⁶⁾ rather than large ash particles termed "popcorn ash". A furnace wall blower test was also carried out to prove the importance of adequate soot blowing of the furnace and its effect on efficiency⁽⁷⁾, and a revised operating procedure was implemented.

3.5 CONTROL SYSTEM

The control system that governs the operation and reaction of the boiler and turbine is complicated and a detailed explanation thereof would contribute to confusion and overshadow the important issues. Only the more applicable aspects that interface with the philosophy of this project will therefore be explained. The unit and turbine controls will not be treated in detail, but only some of the boiler controls, particularly those related to combustion.

The boiler and turbine unit is normally operated in the *Automatic Generation Control (AGC)* mode. This enables National Control to regulate the output of the unit (turbine and boiler simultaneously) according to load and frequency demands termed frequency bias control. This is done by a computerised loading device referred to as ENCOR (see nomenclature). The unit process control provides capability for Boiler follow and Turbine follow modes. The first is where the boiler reacts to turbine load and the latter is where the turbine only generates what the boiler is capable of at that point in time. Variance in generator output is carried out by means of a turbine Load Controller and the corresponding boiler reaction is obtained with the Pressure Controller. The latter operates via a control circuit referred to as the Initial Pressure Set point Formation (Figure 3.22). According to input signals such as the Unit Load Set point, the resulting calculated signals are sent to the Boiler Master controller (Figure 3.23), which controls the boiler. The specific control setup for testing will be explained in more detail in Chapter 5.

A suitable manner to explain the functioning of the control system is to describe the reaction of the applicable components when a load change occurs. As a point of departure, assume the unit is running at steady load. There are no variables on the set points of load, pressures, number of mills in service or fuel oil burner support, etc. Assuming that an increase in load (i.e. power demand) occurs, the response of the control system in cascading mode will be as follows:

Figure 3.22: INITIAL PRESSURE SET POINT FORMATION

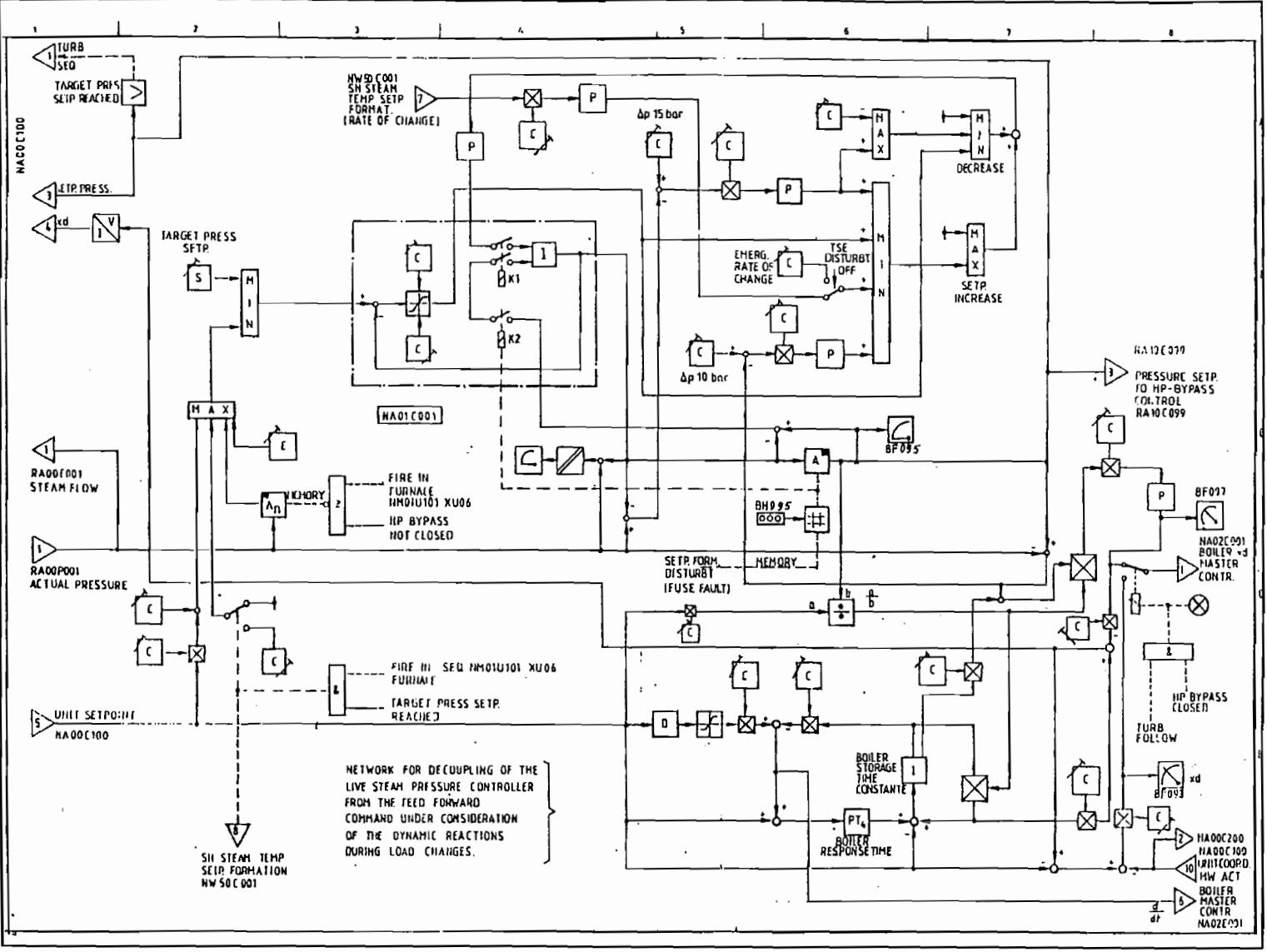
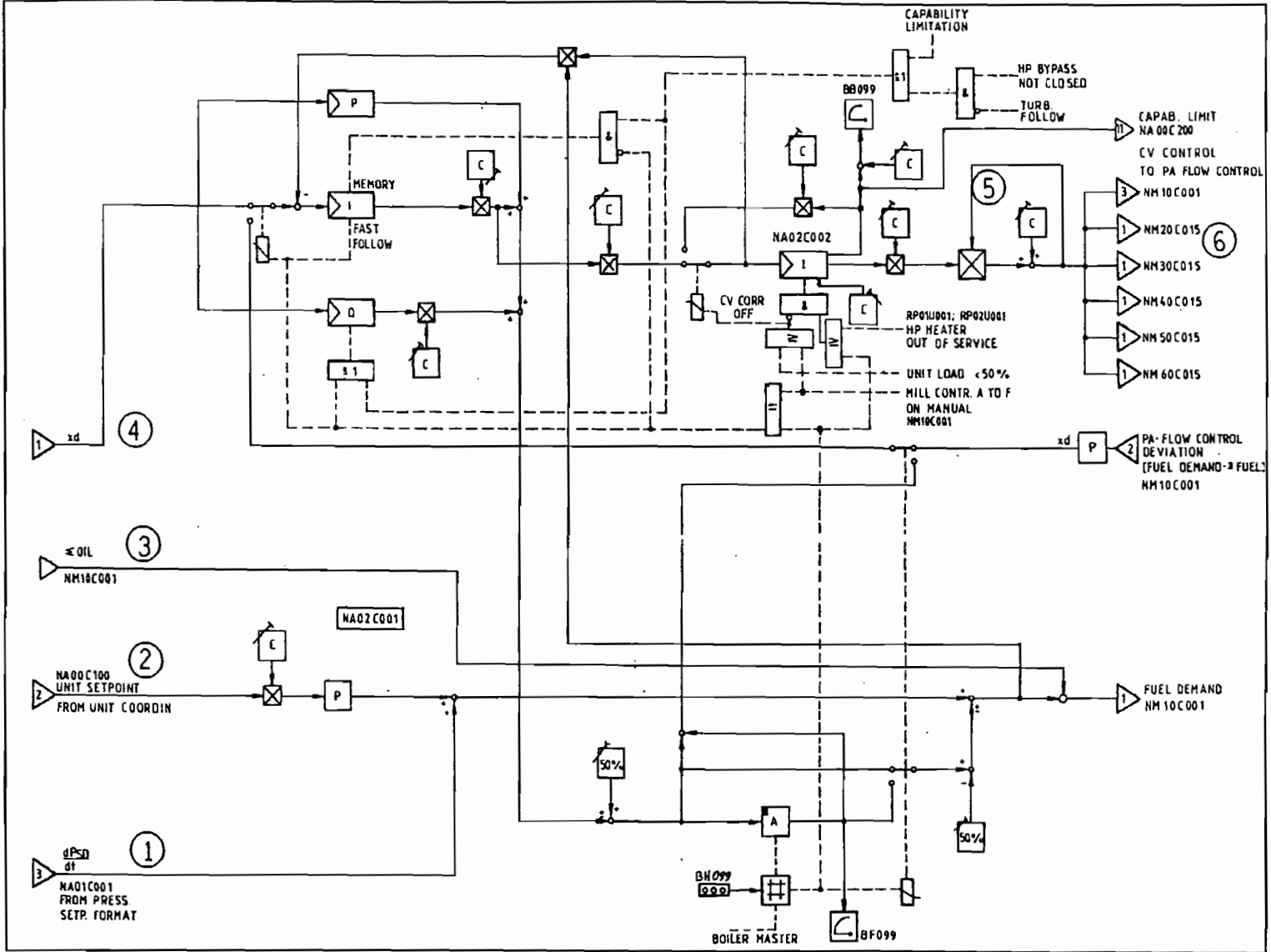

Figure 3.23: BOILER MASTER CONTROL DIAGRAM



The turbine and generator controls will cause the steam governor valves to open further via the speed governor and frequency bias set point. This is to admit more steam to the turbine to provide the increased power required while the terminal voltage is kept constant by means of the AVR. As a result of this there will be a drop in steam pressure in the main steam pipes supplying the high pressure (HP) turbine.

The boiler is normally controlled on the Constant Pressure principle. (The other controlling principle is the Sliding Pressure principle which implies that the governor valves are further open and the quantity of steam flow is controlled more by the feed pumps via the boiler.)

On the Lethabo boilers the Pressure Controller will detect any change or pressure drop and the Boiler Master Controller will instruct the feed pumps to increase the feed water flow to the boiler via the Master Feed signal. This is to enable more steam supply to the turbine. The drum level detection will trim or "fine tune" this signal. Simultaneously, the Boiler Master Controller will instruct the Master Firing control to increase the boiler's firing rate (to enable the additional feed water to be turned into steam and to overcome the pressure drop that existed in the first place). The major signal through which the Boiler Master achieves an increase in firing rate is an increase in PA flow to the mills.

Figure 3.23 shows the Boiler Master Controller input signals. Point (Pt.) 1 is the pressure set point input. This pressure of 16.1 MPa is the target that the controller strives to maintain. Pt. 2 is the unit load co-ordinator set point. Pt. 3 is the fuel oil (if any) to be subtracted from the coal supply. Pt. 4 is the deviation between the actual pressure and set pressure. This is the signal that activates the multipliers at the CV correction (Pt. 5) to send the fuel demand signal to the PA flow signal, Pt. 6. Note that the settings at the CV correction (Pt. 5) are fixed set points. This means that the value is set for the power station's average or expected CV and is not a variable that can change with varying CV or be changed by the operator at will.

The increasing PA flow through the mill will sweep more pf to the burners, thus supplying the additional fuel demand to the furnace. The decreasing level of coal charge in the mill will result in a measurably increasing power requirement to turn the tube mill. This will be sensed by the Power Sonic mill controller and the coal feeder will be instructed to increase the coal flow into the mill.

In Figure 3.24 it can be seen that the PA flow initially activates the feeder (Pt. 1). After the 27th step in the sub group control a release will be given for the switch at Pt. 2 to change the signal to that coming from the Power Sonic controller at Pt. 4. The input signals for the power sonic control is primarily the power for the

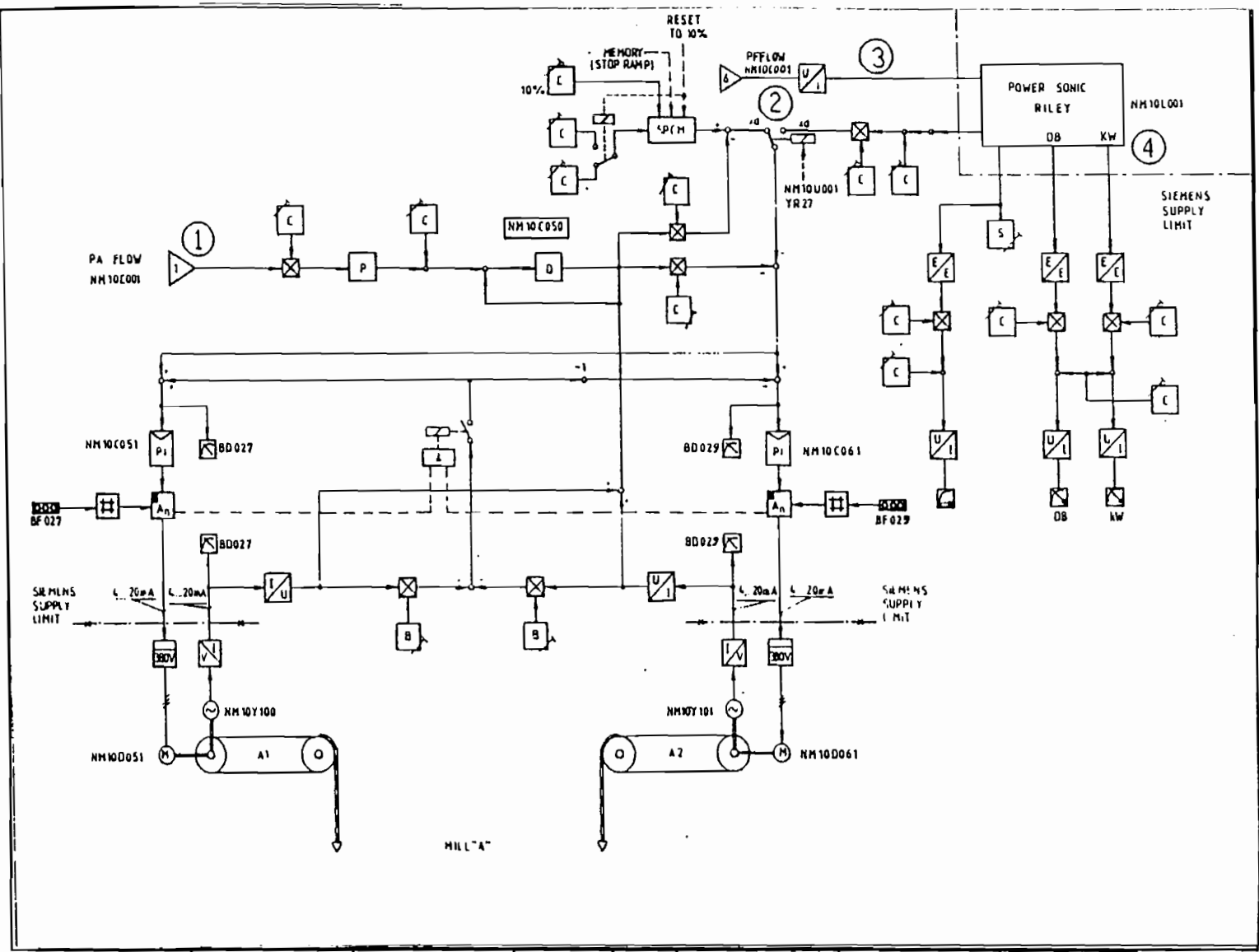

Figure 3.24: COAL FEEDER CONTROL DIAGRAM

mill motor and the sonic verifying signal. The pf signal at Pt. 3 is only a feed forward signal when a load change occurs. It can be seen as an input for the kW and decibel (db) set point. Thereafter it is again the power (kW) and decibel signals from the mill that activate the controlling. The transducers and electronic control cards of the Power Sonic control are tuned to behave according to a prescribed Mill Load line, Figure 3.25.

To render the mill more versatile, a mill PA flow bypass damper is built into the inlet/outlet throat of the mill trunnion. If the PA/pf burner pipes are designed with large enough diameter so as not to throttle the maximum required flow, the diameter will be too large for minimum required flow and pf settling will occur in these pipes. To overcome this problem, a bypass damper is built in to ensure minimum velocity at all times, preventing these pipes being clogged with pf. This can be seen in Figure 3.26 (Pt. 1). What is of importance here is that the total amount of air approaching the mill (as measured by the PA aerofoil and controlled by the rating damper shown in Figure 3.27 Pt. 1) is referred to as PA. The accompanying signal in the control system is also referred to as the PA signal. After the bypass air is subtracted, the remaining air passing through the mill is referred to as a pf signal. This is because this balance of air is proportional to the flow of pf due to it being swept up by this air.

Figure 3.25: MILL LOAD LINE

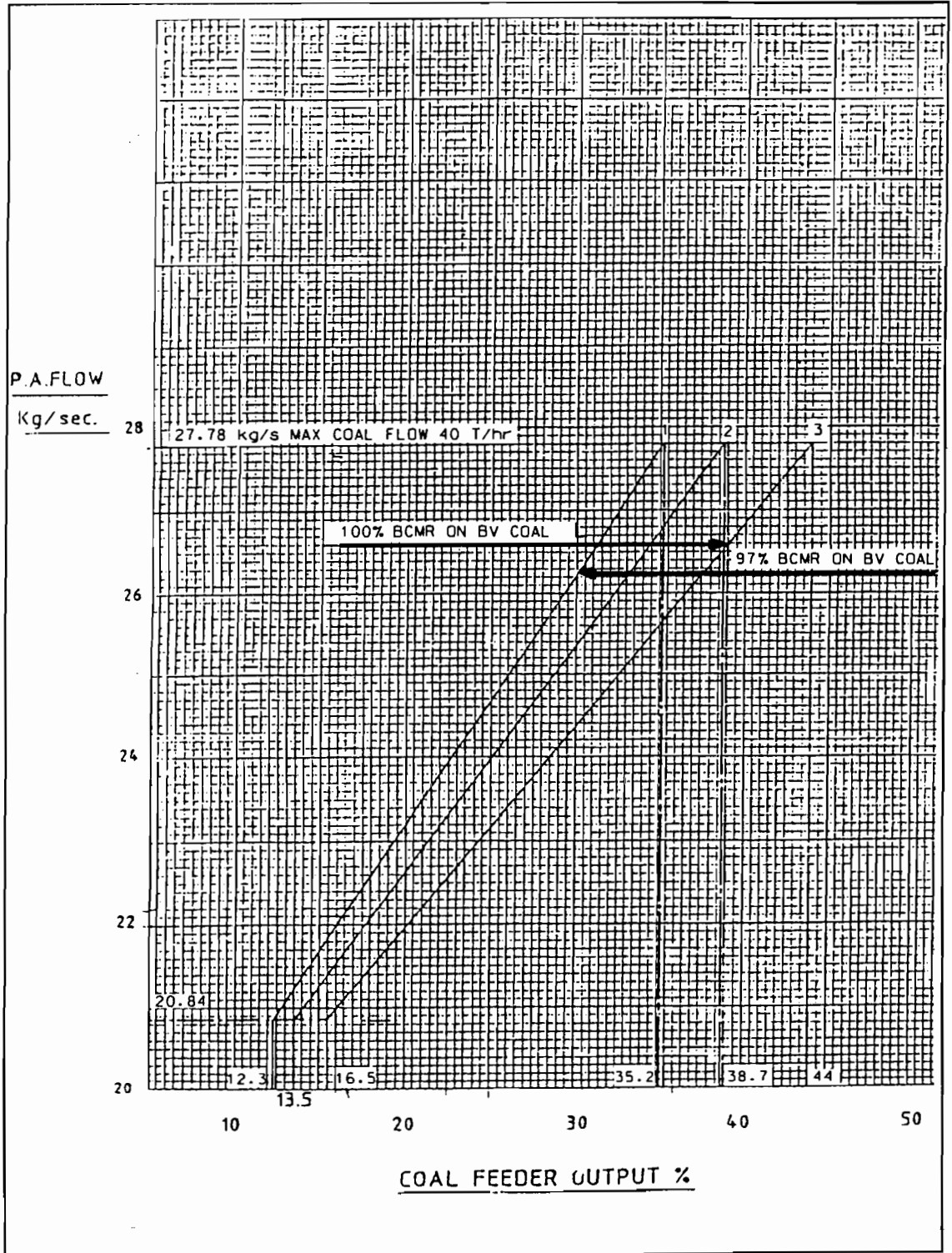

Figure 3.26 : MILL BYPASS FLOW CONTROL DIAGRAM

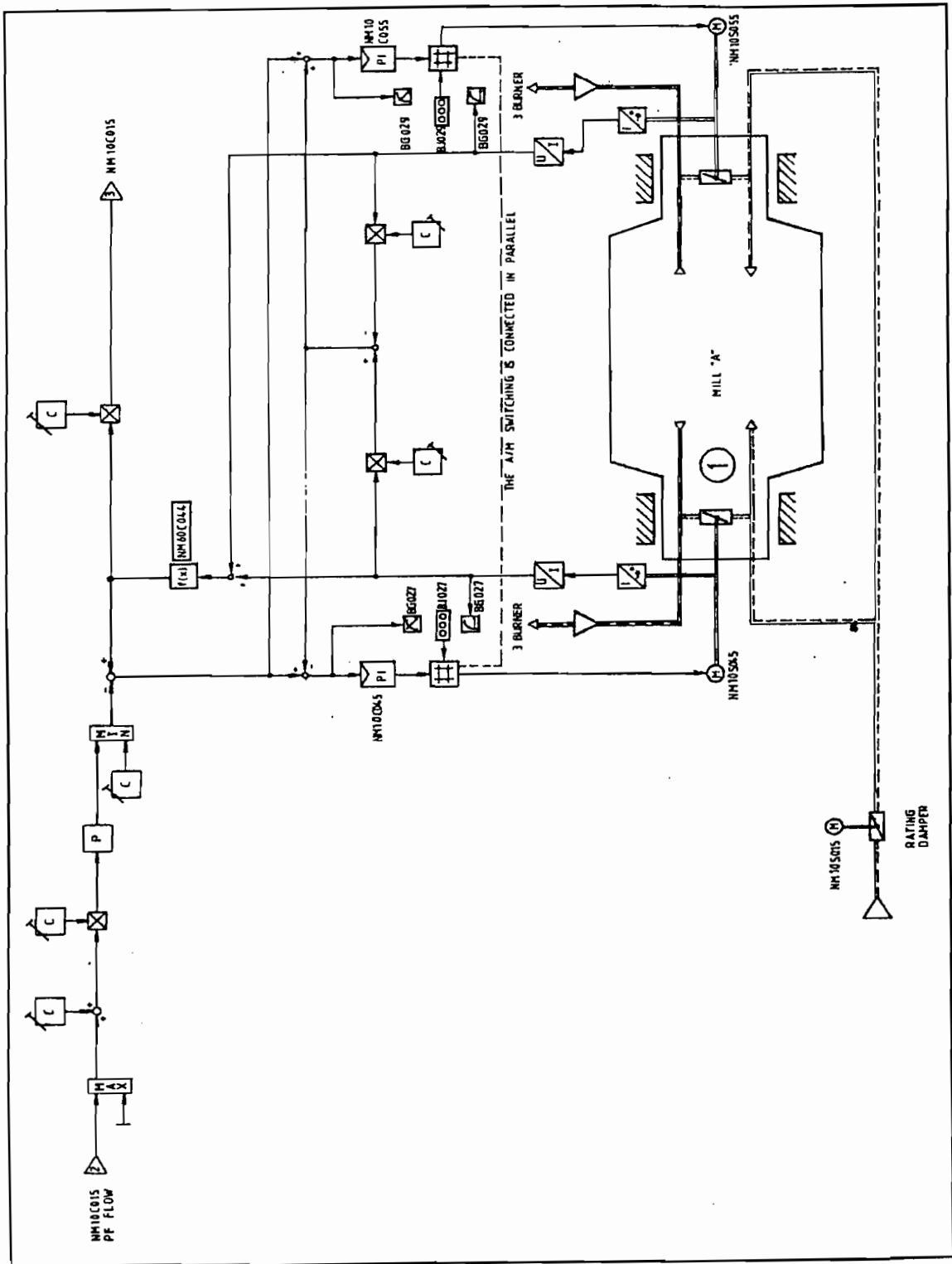
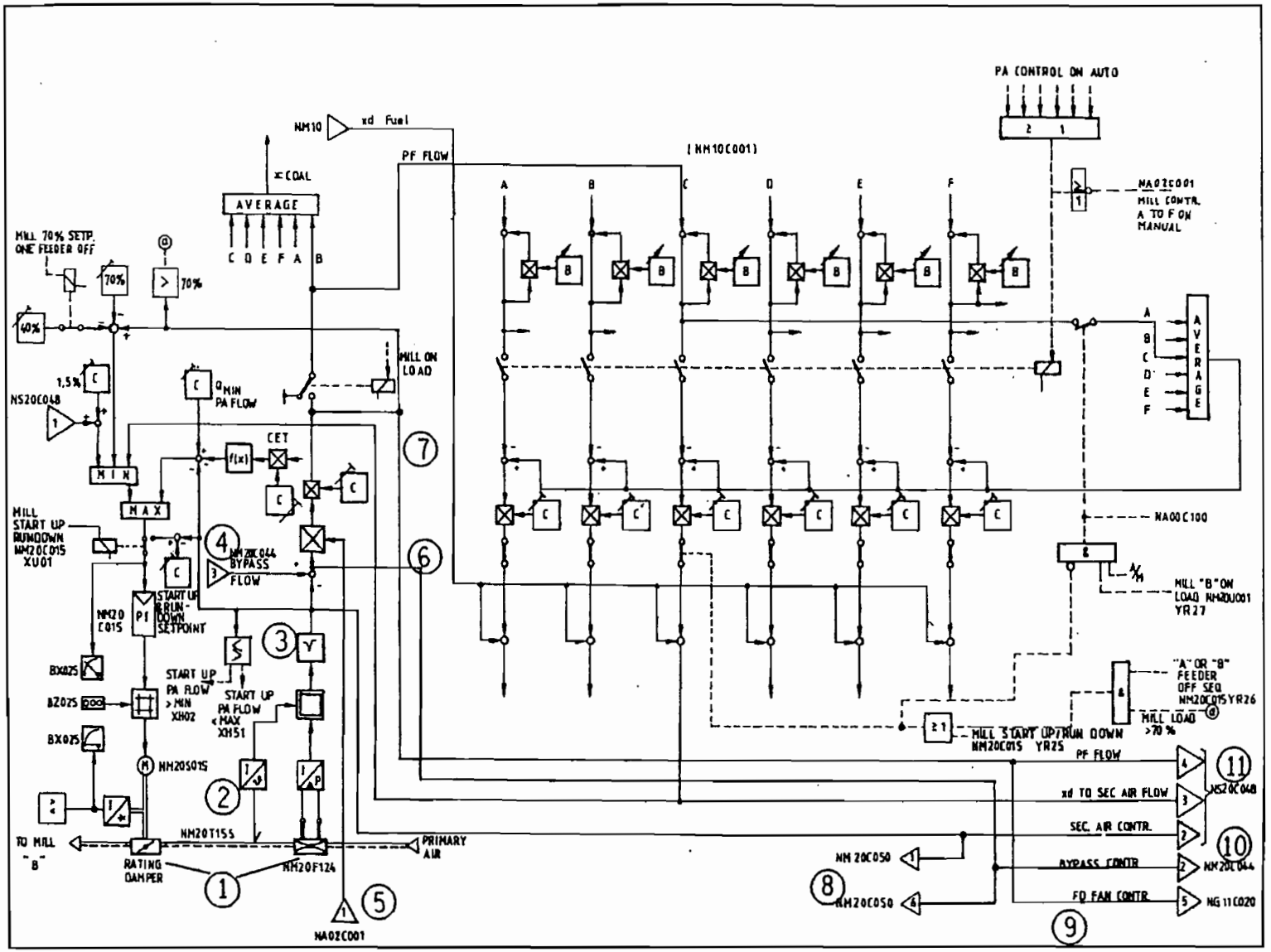

Figure 3.27: MILL PA FLOW CONTROL DIAGRAM



From Figure 3.27 some very important conclusions can be made. The control diagram shows the input requirement from the boiler master, (Pt. 5). The PA flow signal measured at the PA aerofoil and regulated by the rating damper at Pt. 1, undergoes a temperature compensation at Pt. 2 and a square root extraction at Pt. 3 (to produce a flow from a differential pressure).

The bypass air is subtracted at Pt. 4 to produce the pf signal as previously explained at Pt. 6 (PA minus bypass air). This signal which is proportional to the fuel flow, (Pt. 6), goes to the coal feeders at Pt. 8 and the bypass damper controller at Pt. 10. The feedback pf flow signal at Pt. 11 and the forced draught (FD) fan controller, which is total SA, (Pt. 9), receives its signal from Pt. 7 which is the full PA flow, without the bypass air subtracted. (Note: PA + SA = total air.) The result can be seen in Figure 3.28. In short, the PA flow in Figure 3.28 is the PA with the bypass air subtracted i.e. actually the pf signal, in order to vary the secondary air (SA) which is $\pm 75\%$ of the total air, with the amount of fuel for more constant air/fuel (A/F) ratio.

All the above explanations indicate how the controls react when the load increases. The result was the PA and the SA increasing proportionally with the pf signal, i.e. the total air increasing (see Figure 3.29). If the CV of the coal were to decrease the result

Figure 3.28: PA / SA FLOW RELATIONSHIP

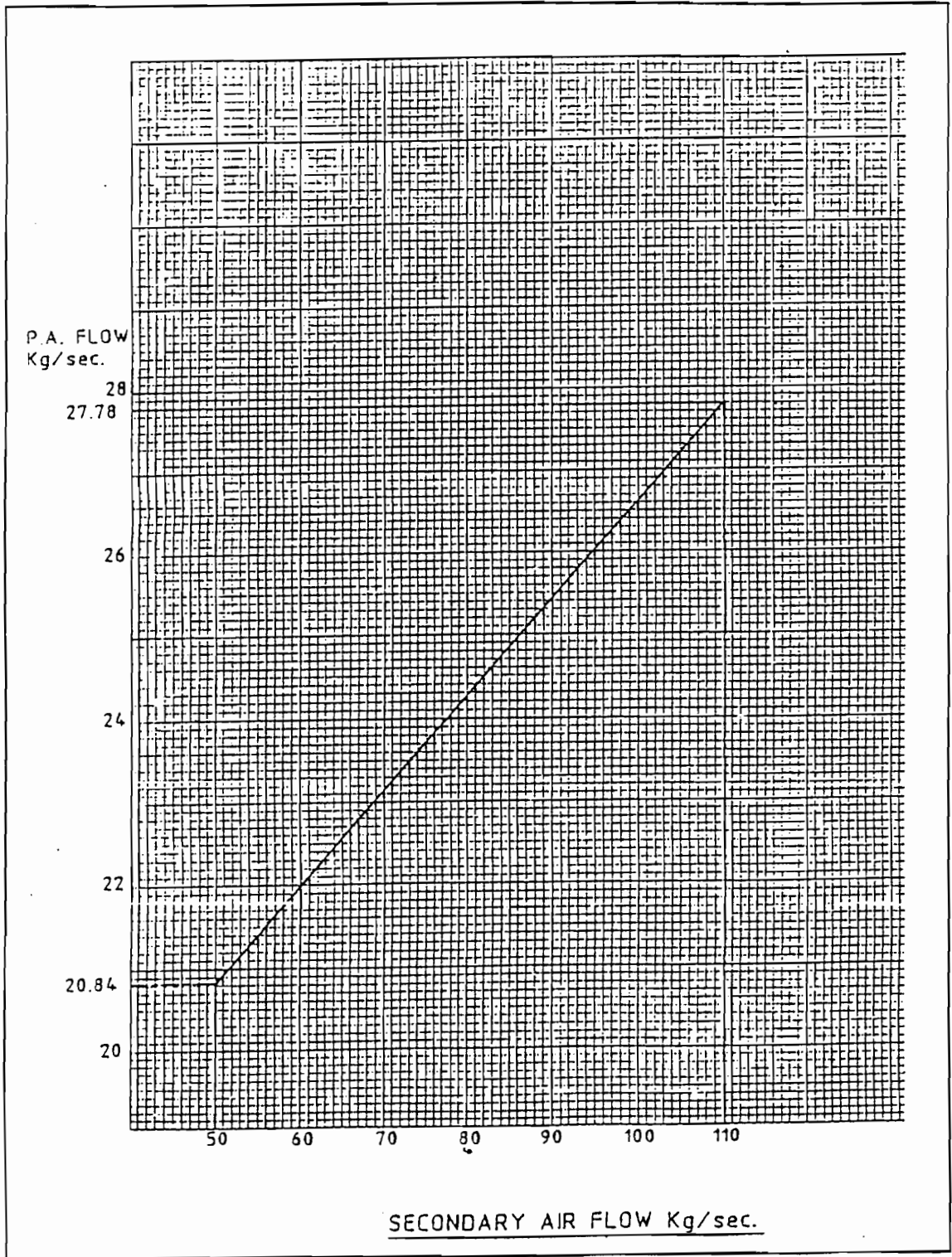
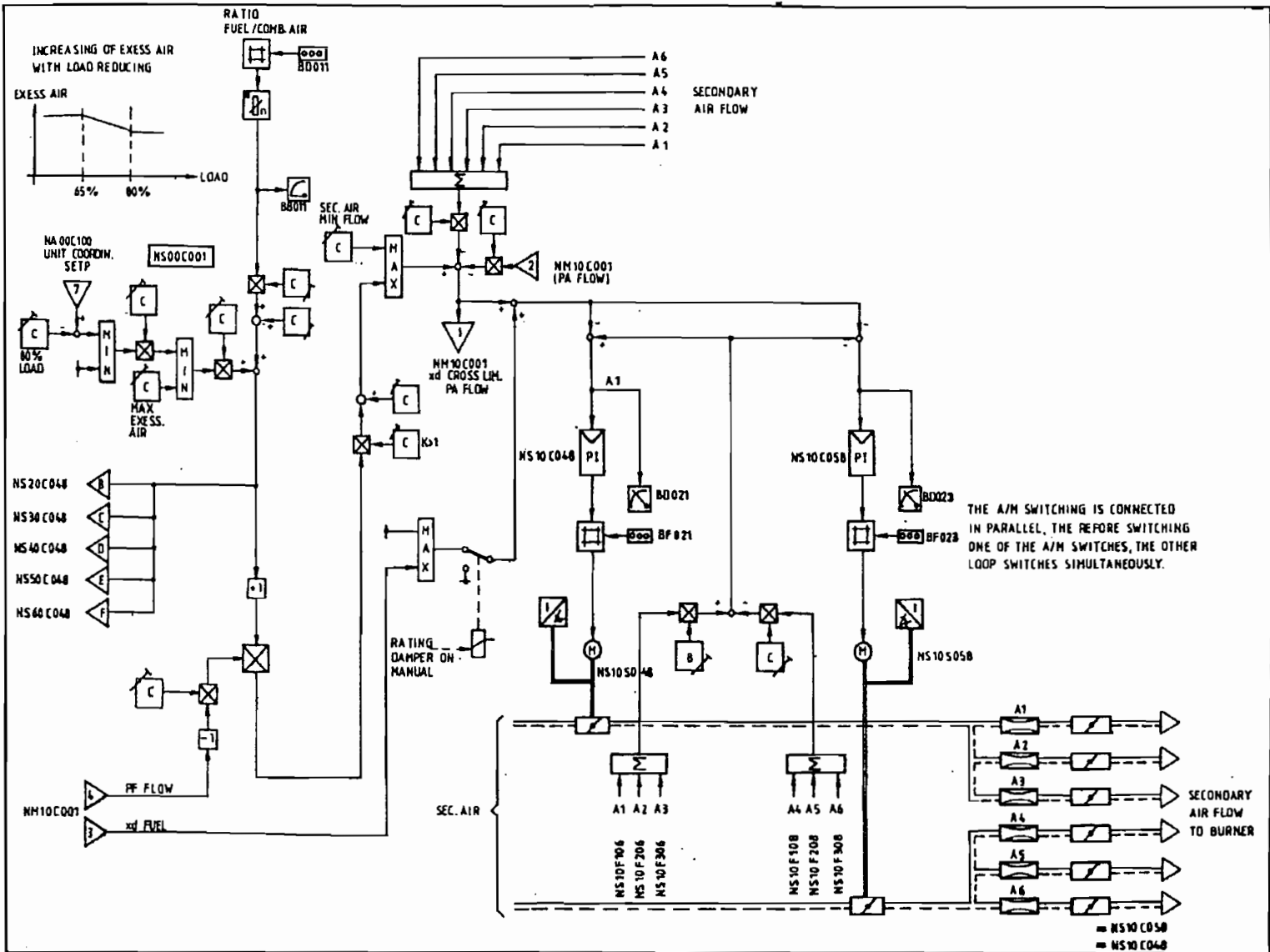

Figure 3.29: SA FLOW CONTROL DIAGRAM



would again be increased total air. This is because more coal would be necessary for the same heat due to its lower CV, increased PA flow would be necessary to sweep it up and convey it to the burners, and the resulting SA and then total air would also increase.

3.6 INSTRUMENTATION AND MONITORING EQUIPMENT

The main equipment monitoring the unit and from which the majority of data will be accumulated is the plant computer, the SICOMP 70. This computer provides information for the process control system which also controls the unit automatically. It has a facility whereby a group log can be compiled to have readings of the selected parameters measured, logged and printed at a preset frequency. Hourly, every couple of minutes, or even seconds can be chosen as frequency while a "snap shot" or instantaneous facility is also available.

There are however certain parameters that cannot be measured by the SICOMP since no measuring points exist, or certain parameters which have to be measured more accurately. The SICOMP relies on transducers and frequent recalibration is therefore necessary. Its accuracy is also influenced by factors such as cold junctions and lead compensation. Plant performance testing also requires a degree of accuracy such that standard instrumentation is not necessarily adequate or the readings achieved may not be representative due to the geometry of the installation.

The SICOMP 70 is however very useful for trending and for providing backup readings. Due to the reasons mentioned above, the following are the important additional monitoring equipment which will provide more accurate measurement of parameters than would be possible by relying on the plant computer data alone, or which cannot be measured by the SICOMP 70 at all:

- The ESKOM TRI mobile caravan. This facility, which is equipped specifically for the purpose of back-end exhaust gas analysis, was used to measure the following parameters very accurately:

- O₂ (percentage)
- NO_x (ppm)
- SO₂ (ppm)
- CO₂ (percentage)
- CO (ppm)

- Codel CO monitors. Concerning gas analysis, there is one aspect, besides the accuracy of O₂, that is considered so important regarding safety that a backup instrument is necessary. This is the CO content of the gas at the ID fan outlet. Two CO monitors, one per outlet duct, were employed in addition to the mobile caravan facility. Where the caravan's CO monitoring operates on the extraction sample principle whereby the sample is passed over a reactivity cell, these monitors are of the infra red cross-duct scanner type. They have

proved to be very reliable, sensitive and accurate in the past.

- Pitot - static tube. This basic flow measurement device is very accurate if used correctly. It is normally used in conjunction with an accurate manometer to measure a differential pressure to obtain a velocity from the dynamic pressure ($P_{dyn} = P_{stag} - P_{stat}$) and finally a flow. Pitot - static tubes were used to determine the main gas velocity stream in order to obtain representative measuring points on the four air heater outlet ducts (Appendix B). It was also used to determine air in-leakage into the furnace via the mill seal air fan suction ducts during testing (chapter 5).

- The Economiser outlet sampling Matrix. Two very important parameters that need to be sampled very accurately and especially very representatively is the oxygen and fly ash content of the flue gas at the economiser outlet before the air heaters. The percentage oxygen here is also a legal requirement as stated in the Pf code of practice⁽⁸⁾. The standard oxygen measuring equipment supplied with the boiler consists of a single 20mm diameter extraction pipe on the upper side of each of the two rectangular ducts measuring 5 x 11m. This was considered inadequate and inaccurate. Consequently a 16 probe sampling matrix was designed and installed at Lethabo Power Station (Figure 3.30), whereby the sampling of fly ash and oxygen content was carried out isokenetically, much more representatively, and continuously.

Figure 3.30: FLUE GAS AND FLY ASH SAMPLING MATRIX

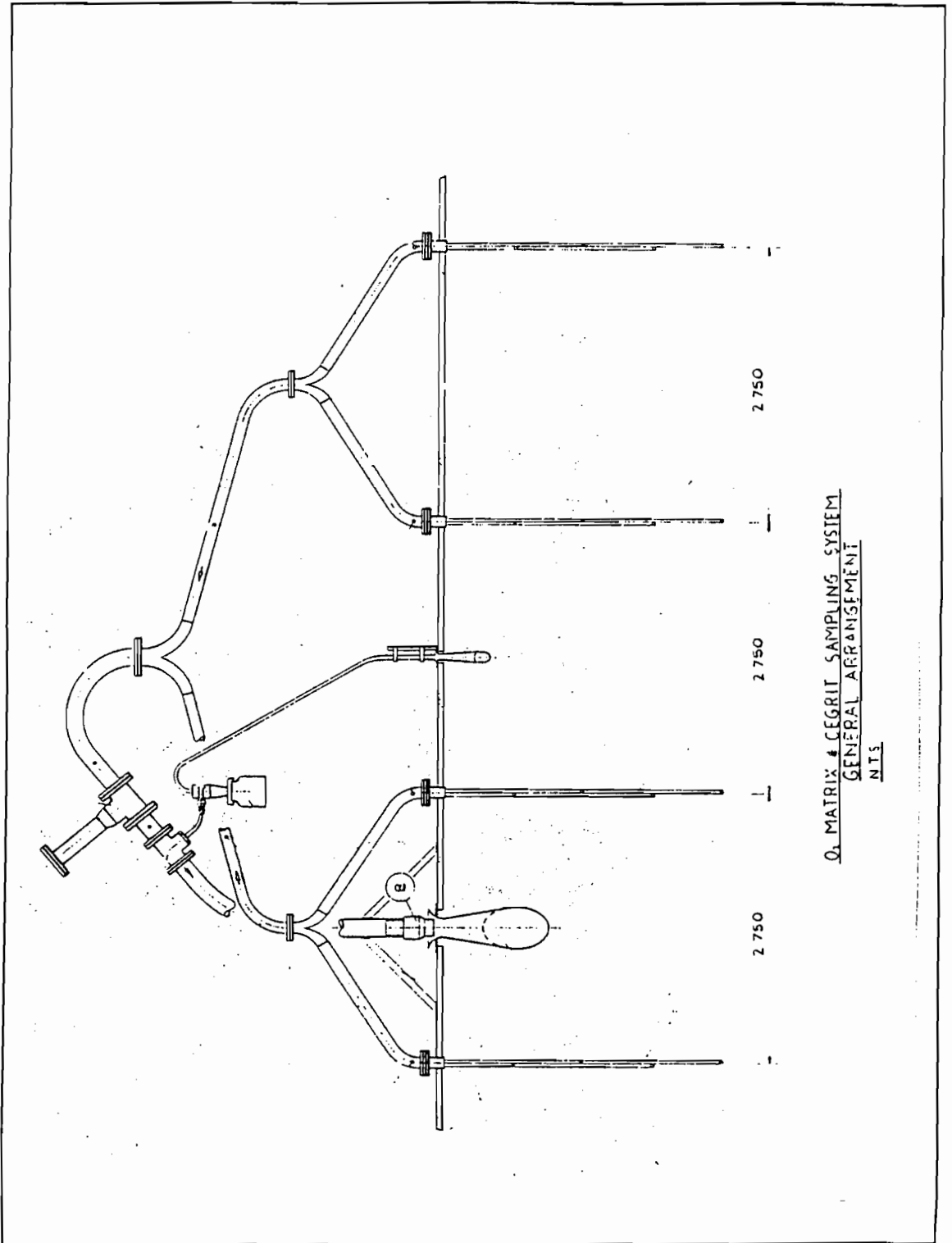

- The OTOX 91 Portable Oxygen Analyser. This is a small compact portable instrument which has proved to be very reliable and accurate. It is also easily calibrated with test gas (3% oxygen) in its operating range of 0 - 35% oxygen by volume. It was used to obtain correction factors for the economiser outlet oxygen on a daily basis as well as to measure the air heater outlet oxygen content on a continuous basis during testing.

- Digital read-out Thermocouples. These pre-calibrated portable instruments were used to measure the flue gas temperature at predetermined representative points of the air heater outlet ducts.

- Digital display Vane Anemometer. These pre-calibrated instruments with correction figure graphs were used to measure the air in-leakage into the furnace via the burner core air tubes during testing.

- Wetbulb/Drybulb Thermometers. These instruments were used to measure the air intake temperatures into the furnace and to calculate the relative humidity of the combustion air.

- Dual Limb Incline Manometers. The total air flow was calculated from basic principles and differential pressure measurements taken with this manometer installation connected to the total air measuring aerofoils (Figure 3.31). Compensation for

Figure 3.31: CROSS-SECTION OF MEASURING AEROFOIL

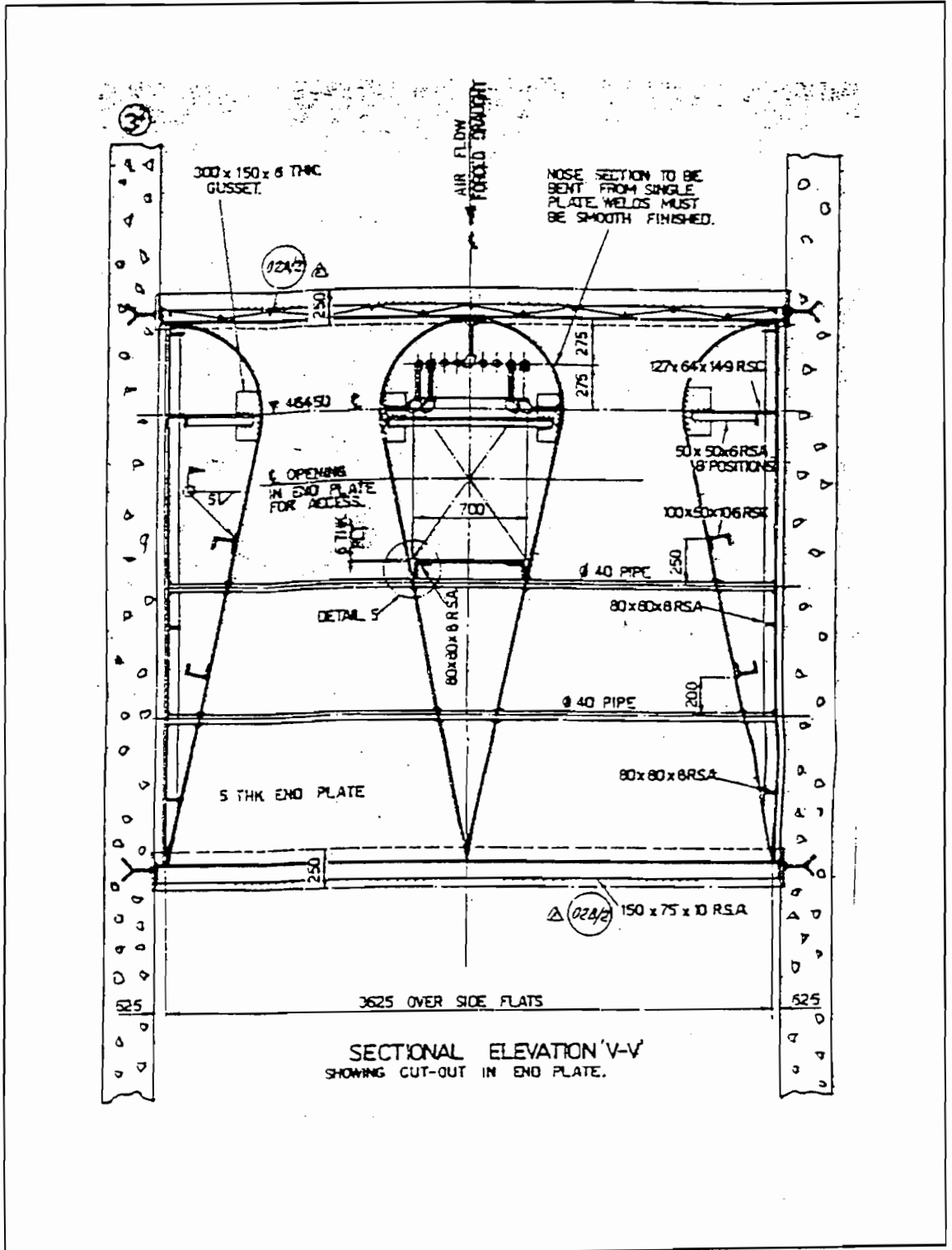

temperature, relative humidity and Ca factor was done as explained in sample calculation 2, Appendix A.

- **Isokinetic Pulverised Fuel Sampler.** Isokinetic sampling is achieved when the sampling velocity within the nozzle is equal to the velocity in the immediate vicinity of the nozzle. This is of utmost importance for accurate evaluation of mill performance. This sampler and procedure (Appendix J) was used to sample the pf of a representative mill on each test for particle size distribution (Chapter 5). The mill optimisation and enhancement that preceded these tests was also evaluated by this means (Chapter 4) since particle size is of utmost importance in this project. This equipment included the drying oven and shaker with its sieves for the grading process.

- **Feed Water Flow High Pressure Orifice Plate.** The accuracy of the mass flow of the working fluid is very important. Since the STEP calculations are very sensitive to feed water flow to the boiler, a special laboratory calibrated orifice plate was installed in a Sempell block specifically designed to accommodate the plate (Figure 3.32). Special high pressure transducers were employed with appropriate conversion and correlation factors to produce accurate flow values. See sample calculation 4 (Appendix A).

Figure 3.32: FEED FLOW HIGH PRESSURE ORIFICE PLATE

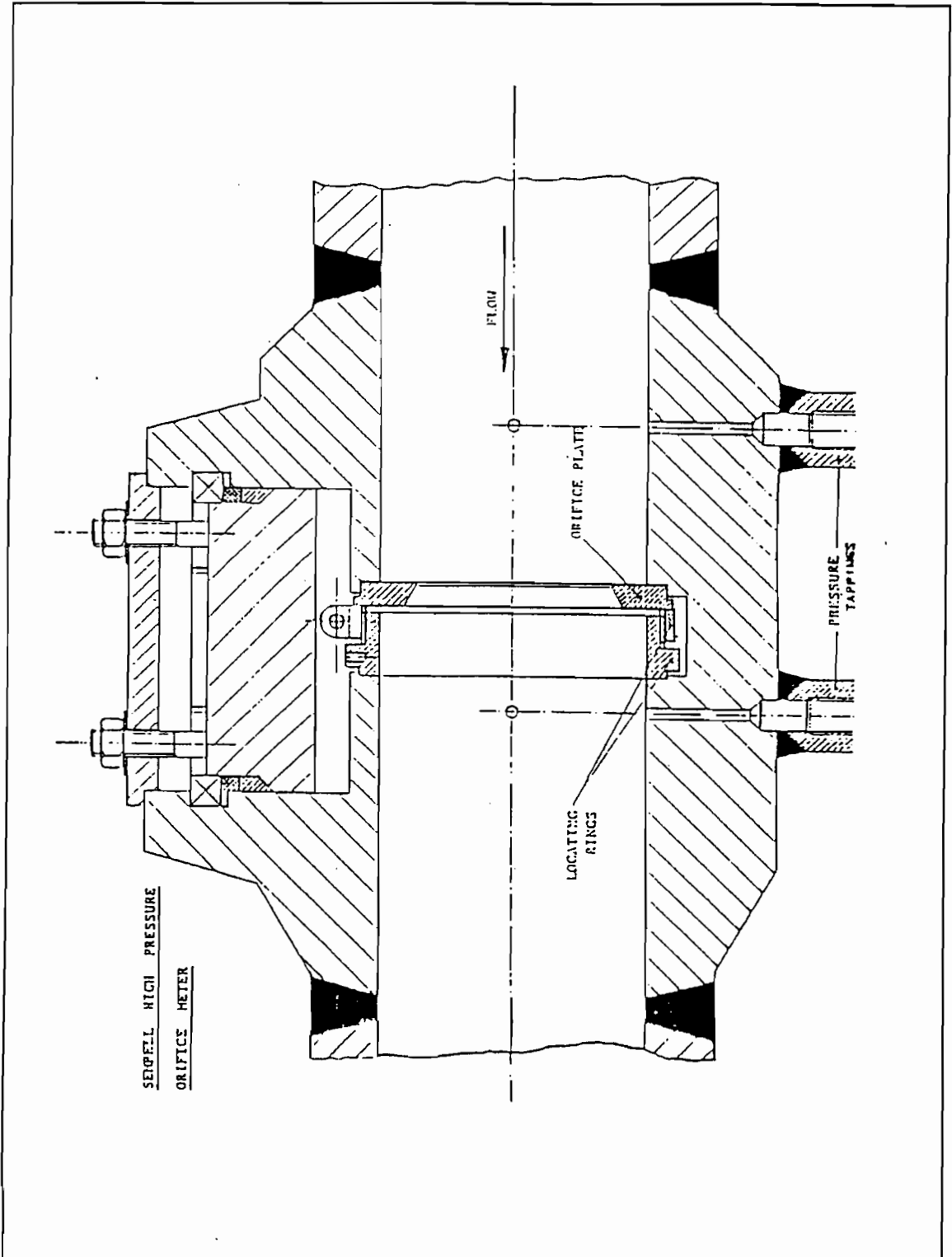

- Volumetric Coal feeders. On the combustion side the coal flow is very important. The coal volume flow was measured by means of the feeder integrators. The feeder bars were set according to the required dimensions and a correction factor was used to determine mass flow from the volume flow obtained from the feeder integrators. See sample calculation 5 (Appendix A).

More perspective of the above preparations and measurements will be discussed in chapter 4.

3.7 COMPUTER SOFTWARE AND EFFICIENCY PROGRAMS

There are three programs utilised by ESKOM for calculating thermal efficiency or heat rates. These programs will be discussed functionally only, highlighting their advantages and disadvantages. No programming or software details will be discussed.

Firstly, there is the PEPSE program (Performance Evaluation of Power Station Efficiencies). This is a comprehensive heat rate calculating program that can handle the smallest detail and process of plant. Its operating principle is that a process model can be built up to serve as a reference. Simulations can be run for certain variances of the model, e.g.: what would the turbine cycle heat rate be if a HP feed heater is bypassed, or if the condenser cooling water temperature changes by a certain amount? The disadvantage of this program is that

it is very complex. In order to obtain full benefit from this program a person would have to be appointed on a full-time basis to utilise the system and analyse results. At first the PEPSE program was only equipped for the turbine plant but it was recently expanded to include the boiler. At the time of writing it is being tested in the evaluation of the unit in its entirety and not only in handling the turbine and boiler as separate entities. The PEPSE program is a very good design tool to establish for example turbine plant design specifications.

The second program is based on BS2885, 1974⁽⁹⁾. This British Standard is commonly used internationally and was used by ESKOM TRI at the time of the Lethabo excess air reduction tests (Potgieter⁽⁵⁾). It was also used to evaluate Guarantee Acceptance Testing of new units built by contractors for ESKOM. It is based on the losses or indirect method. It only addresses the boiler and not the turbine or the entire unit. The losses that can be measured are:

- Combustibles in ash
- Radiation loss
- Sensible heat of water vapour
- Dry flue gas
- Wet flue gas
- Moisture in combustion air
- Combustible (unburnt) gas

Although BS2885 deals with the last three losses to a greater extent than does STEP, which includes them in the unaccountable losses, it does not take into account certain other losses that STEP does. This program is the best for Guarantee testing where a specific efficiency value is to be achieved, using the indirect method by evaluating specific losses stipulated in a specification.

The third program is STEP (see nomenclature). It is used on every thermal power station in ESKOM by plant performance personnel to monitor and evaluate the hourly, daily, weekly or monthly thermal performance of individual units as well as that of the station. It can also simulate performance in real time mode by entering for example a series of hourly readings averaged as a "snapshot". It operates on both the direct and indirect method simultaneously where the unaccountable losses make up the difference between accounted losses and 100%. This is the best cross-controlling method to minimise calculation and monitoring errors.

STEP also calculates a sliding target for each loss and compares the actual loss to the target to form a percentage STEP loss. It furthermore evaluates the boiler, turbine and entire unit simultaneously. The twelve most important losses measured are:

Overall station:

- Demineralised water make-up
- Auxiliary power

Turbine:

- Condenser vacuum
- Final feed water temperature
- Main steam temperature
- Reheat steam temperature
- Turbine deterioration (isentropic expansion efficiency)

Boiler:

- Boiler radiation
- Mill rejects
- Hydrogen and fuel moisture
- Unburnt carbon
- Dry Flue gas

STEP has never before been used outside its original purpose of a trending tool for evaluating plant history. However, it holds the potential as being the best optimising tool presently available. The intention was to utilise STEP in these tests since it had already proved itself in this mode during the Air Flow Optimisation tests (Storm⁽²⁾).

The main efficiency calculations of this project were performed by the STEP system personal computer (PC) facility. A model can be constructed, tuned and customised for a specific situation whereafter simulation runs can be performed. For the purposes of these tests, some modifications were made to the STEP formulae and targets. The compensation to dry flue gas loss due to dilution caused by air in-leakage (sample calculation 3) and the compensation to unburnt carbon energy due to varying ash quantity in coal, were two such formulae modifications. The sliding targets of auxiliary power consumption and dry flue gas loss proved to be erroneous and were also corrected for the calculations of these tests.

3.8 COAL AND THE BLENDING STOCKYARD

Due to its unique composition, the Lethabo coal is just as important a research topic as the plant itself. The coal quality used for testing in this project was extremely poor by international standards for pulverised fuel technology. The main reason for this is the higher volatile matter of those coals compared to the Lethabo coal. The low volatile content of the Lethabo coal is one of the crucial matters around which this project evolves. The high ash percentage of this coal also presents greater erosion problems in the boiler as well as severe stack emission problems. Fortunately however the ash properties present relatively favourable clinkering characteristics due to the high fusion temperatures. The properties of the Lethabo coal relative to other South African and European coals can be seen in

Table 3.2.

Table 3.2: COMPARATIVE AIR DRIED COAL PROPERTIES

COAL PROPERTIES	IN SITU COAL RESERVES			CONTRACTUAL COAL QUALITIES			LETHABO	MATIMBA	DRAX	BROWN COAL
	minimum	maximum	average	minimum	maximum	Base value	{(GUAR. TEST)}	(RSA)	(UK)	{(GERMANY)}
CV (MJ/kg)	11.1	23.5	17.2	15.0	17.0 (total)	16.0	15.2	20.1	26.4	20.0
Inherent moisture %	1.6	9.6	5.9	7.0	15.0	12.5	4.5	2.2	4.3	30.0
Ash %	21.1	47.8	33.7	27.0	41.0	37.5	37.8	34.5	18.1	5.0
Volatile matter %	10.5	26.8	20.8	16.0	23.0	19.5	21.1	27.2	28.9	44.0
Fixed carbon %							36.67	36.10	48.70	36.00
Total carbon %							43.75	48.19	64.39	68.00
Hydrogen %							2.83	3.59	4.16	5.00
Nitrogen %							.99	1.16	1.38	1.00
Sulphur %	.15	2.97	.75				.59	1.09	1.26	.50
Carbonates %								1.12	.50	
Oxygen %							9.60	8.15	5.91	25.00
Abrasiveness mgFe/kg	50	1095	237	130	800	450				
Ash fusion (IDT) °C	1210	1400	1390	1200	1400	1300				1400
HIV %							20.87	40.94	39.52	40.96

From the values of CV, ash and especially volatile matter (Table 3.2), it can be seen that the characteristics of the in situ coal reserves of Lethabo Power Station span a very wide range from minimum to maximum. In general, it is not feasible, and in many aspects

impossible, to design a power plant that can accommodate feed stock with such a large variance. It is therefore essential that coal blending takes place before it enters the power station. The coal has to be blended for CV as main criterion, with other prerequisites for minimum or maximum values of ash, volatile matter and moisture, etc. These values form the contractual limits in Table 3.2 (see coal contract⁽¹⁰⁾).

The layout of the coal blending stockyard can be seen in Figure 3.33. The intention here is not for a detailed study of the stockyard but rather to gain an overview and to take note of certain functions thereof. The entire coal supply side of Lethabo Power Station, i.e. New Vaal Mine, consists of three functional areas. The first is referred to as the "Pit" which is an opencast mine and where the coal under discussion originates in three relatively shallow seams. The raw coal is taken from these seams in approximate portions averaging 30,4% from the top seam, 43,5% from the middle seam and 26,1% from the bottom seam, as per contract⁽¹⁰⁾. The coal enters the second area which is referred to as the "Plant" by conveyor belt (North Eastern side of Figure 3.33). About 40% of the coal undergoes beneficiation (destoning) in a DMS (dense media separation) plant. Mass meters used for payment, an assized bin for mass meter calibration and a sampler for checking coal quality, are also incorporated.

Figure 3.33: COAL BLENDING STOCKYARD IN PLAN

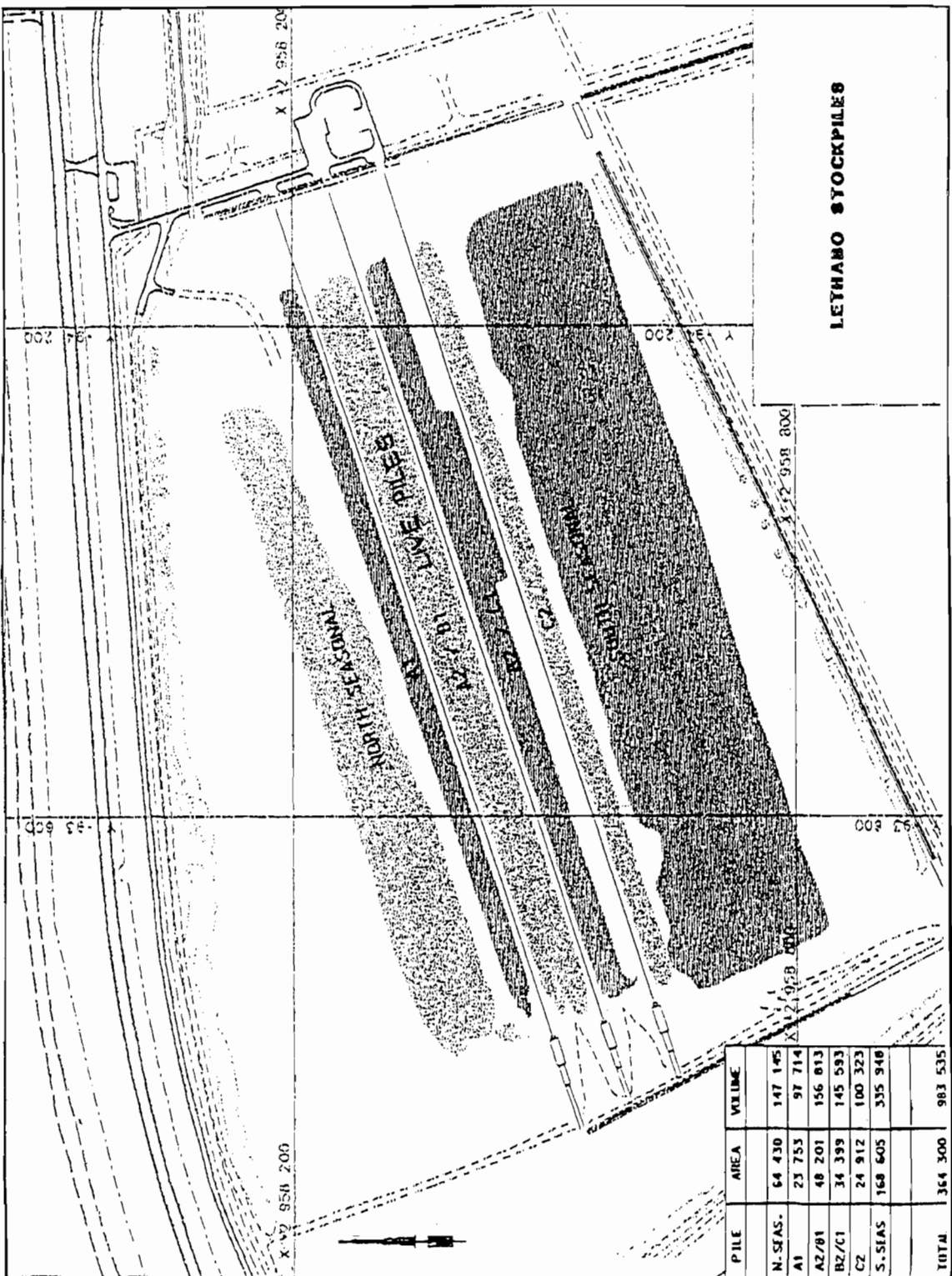

The third area is the blending stockyard. It consists of a Northern and Southern compacted strategic stockpile. In between these stockpiles lie the live stockpiles where the coal is blended. This is basically achieved by means of three rail mounted mechanical stacker-reclaimers. The in-coming coal is stacked by either the windrow or the chevron methods. Both methods utilise the principle of stacking the in-coming coal with different qualities in a horizontal manner in layers and reclaiming it in a vertical manner, thus taking a certain ratio of coal at different qualities. This quality is pre-calculated to provide a quality within the range as per contract. On the outgoing side of the stockyard mass meters and a sampling plant is also installed.

There is also a facility for bypassing the blending yard in the event of emergency coal demand from the power station. This project may also review minimum standards of coal quality during bypassing actions.

Figure 3.34 shows a functional flow diagram of the plant and blending on the live stockpiles, each of which can store almost one million tons. This project may also highlight the need for an on line coal quality monitoring scanner or moisture analyser to predict certain coal properties prior to entering the power station. The original facility was removed due to the unreliability of readings. It should be noted that at Lethabo the ratio between volatiles and CV of the

coal is not constant. The results of present research and development is anxiously being awaited. There are no coal storage staithes at Lethabo. Each boiler is provided with a coal silo holding 5550 tons which in turn serves six bunkers, each of 800 tons capacity, one each per mill.

The calculation and ordering of the coal for the tests will be discussed in chapter 4. The low grade coal for these tests (low CV, low volatile type) is in abundance in the pit. The intermediate coal was blended in the normal supply mode. However, a problem arose with the acquisition of high grade coal for this test. Although the required quality of high grade coal was available in the pit, it did not occur in large enough homogenous volumes to extract directly for testing. It was therefore decided to utilise the old Vaal coal stockpile where almost a million tons of coal was available. Vaal was an old ESKOM power station which was recently decommissioned. Calculations (see chapter 4) established that the quality of this coal was very close to the high grade required for the test. It was also more economical and practical to use this coal directly in unblended form, rather than the high grade coal from the pit. Although the coal was sold by ESKOM, the negotiations were timeous enough to recover an adequate quantity for testing.

3.9 ELECTROSTATIC PRECIPITATORS

The Electrostatic Precipitators (ESP) were not to be tested as such, but varying air flow of the combustion process greatly influences ESP performance. Precipitator efficiency decreases with increasing gas velocity through the fields. Although combustion was the main criterion in this project, cognisance was taken of the corresponding changes in ESP performance and stack emissions.

Due to the high percentage of ash in the Lethabo coal (sometimes over 40%) this power station is equipped with one of the largest precipitators in the world at the time of construction. The following are some design data for the Lethabo precipitators:

Efficiency at 97% MCR	Base value coal	worst coal
All fields in service	99,88%	99,86%
One field out of service	99,85%	99,81%
Dust burden	30 g/m ³	30 g/m ³
Pressure drop	0,25 kPa	
Temperature drop	11 °C	
Gas velocity	1,2 m/s	

Inlet:

Dust concentration	38 g/m ³ (actual)
Dust concentration	68.7 g/m ³ (standard)
Ash mass in	39,3 kg/s

Outlet:

Dust concentration	82 mg/m ³ (actual)
Dust concentration	147 mg/m ³ (standard)
Ash mass out	84 g/s

Construction: (see Figures 3.35, 3.36, and 3.37)

Parallel casings	Four
Series fields per pass	Seven
Plate height	14,8m
Plate length	5m
Aspect ratio	2,4
Plate area	190624 m ²
Flow area	817 m ²
Specific collecting area	191.6 s/m

Transformer/rectifiers:	Per field	Per boiler
Sets	28	
Output voltage	35 kV	50 kV
Output current	47,6 A	1 A
Output power	565,6 kW	1824 kW

Figure 3.35: GENERAL PRECIPITATOR CONSTRUCTION

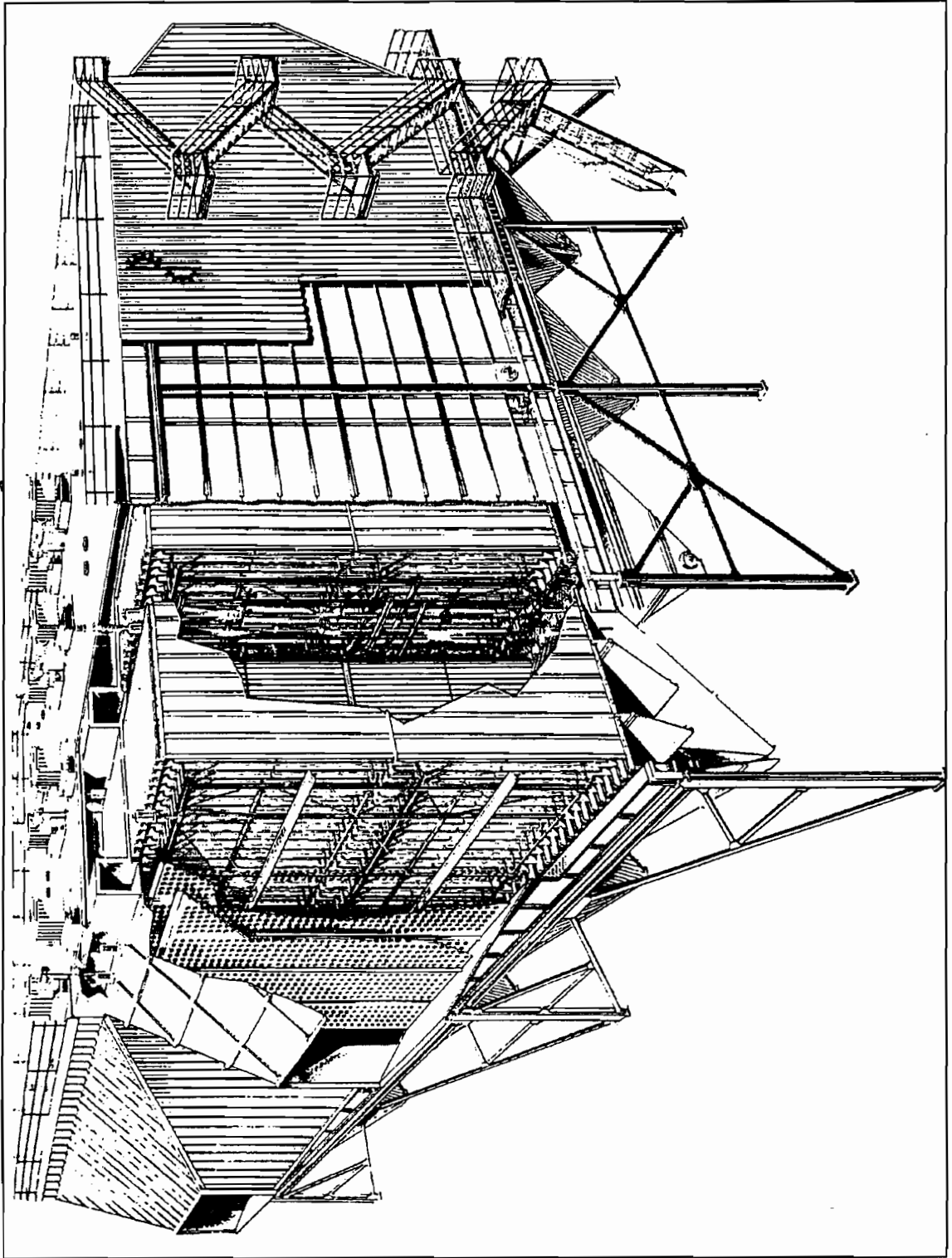

Figure 3.36: SIDE VIEW OF PRECIPITATOR CASINGS

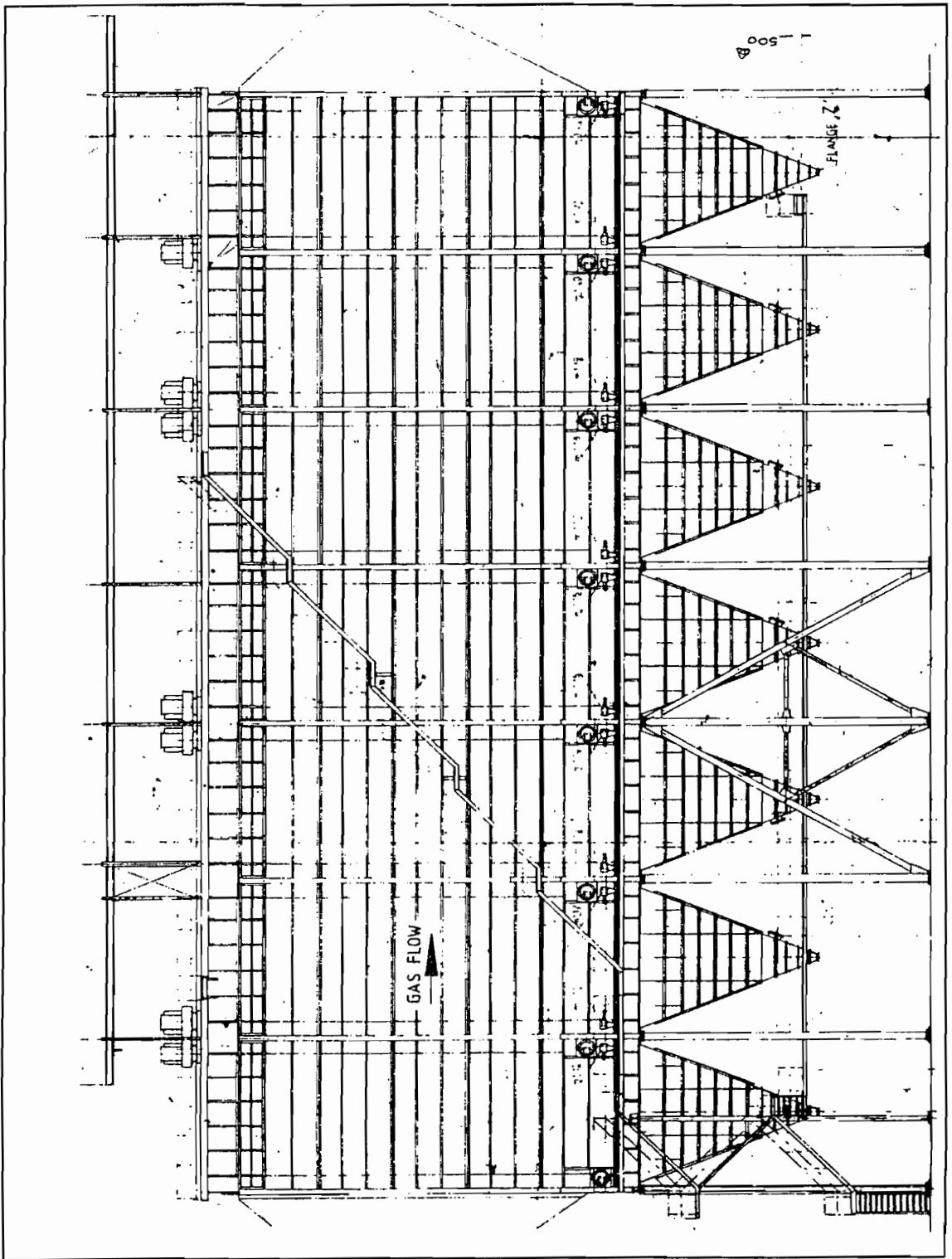
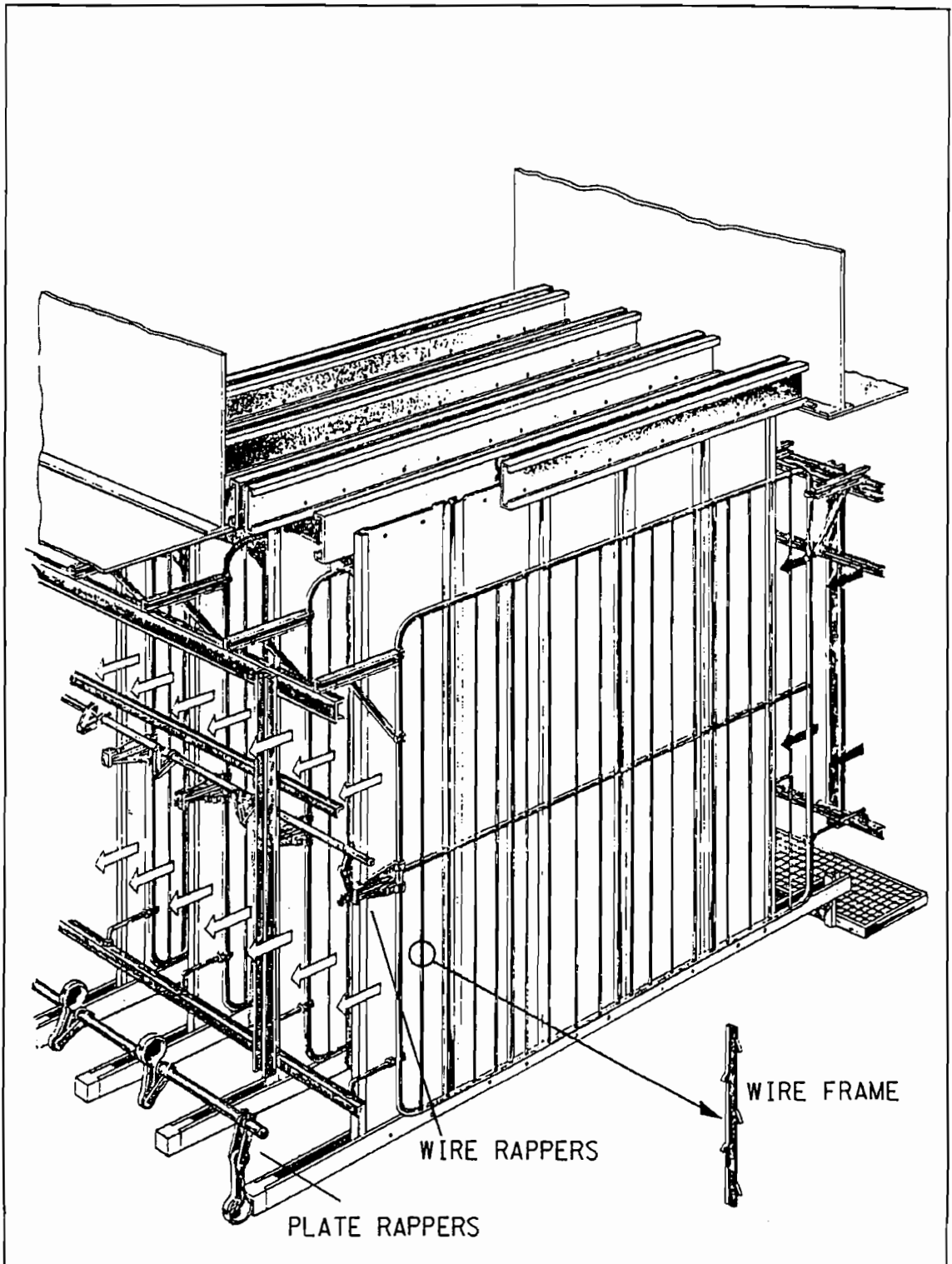

Figure 3.37: ARRANGEMENT OF PRECIPITATOR ELECTRODES AND RAPPERS



Typical ash analysis:

Silicon (as SiO ₂)	51,8 %
Aluminium (as Al ₂ O ₃)	34.3 %
Iron (as Fe ₂ O ₃)	3,5 %
Titanium (as TiO ₂)	1,7 %
Phosphorous (as P ₂ O ₅)	0,4 %
Calcium (as CaO)	4,6 %
Magnesium (as MgO)	1,2 %
Sodium (as Na ₂ O)	0,1 %
Potassium (as K ₂ O)	0,4 %
Sulphur (as SO ₃)	0,1 %
Manganese (as MnO)	0,03 %
Unburnt carbon	0,3 %

An enhancement program was undertaken on the Lethabo precipitators during 1989/90. This involved the retrofitting of microprocessor controllers to all fields. This resulted in reducing emission levels especially under adverse conditions such as poor coal quality and field outages. These controllers also reduced the precipitator power consumption from 4,2 MW to the 1,8 MW as stated above. The optimisation of rapper settings also served to reduce emission levels.

Figure 3.38: PRECIPITATOR CORRELATION CURVE - UNIT 1

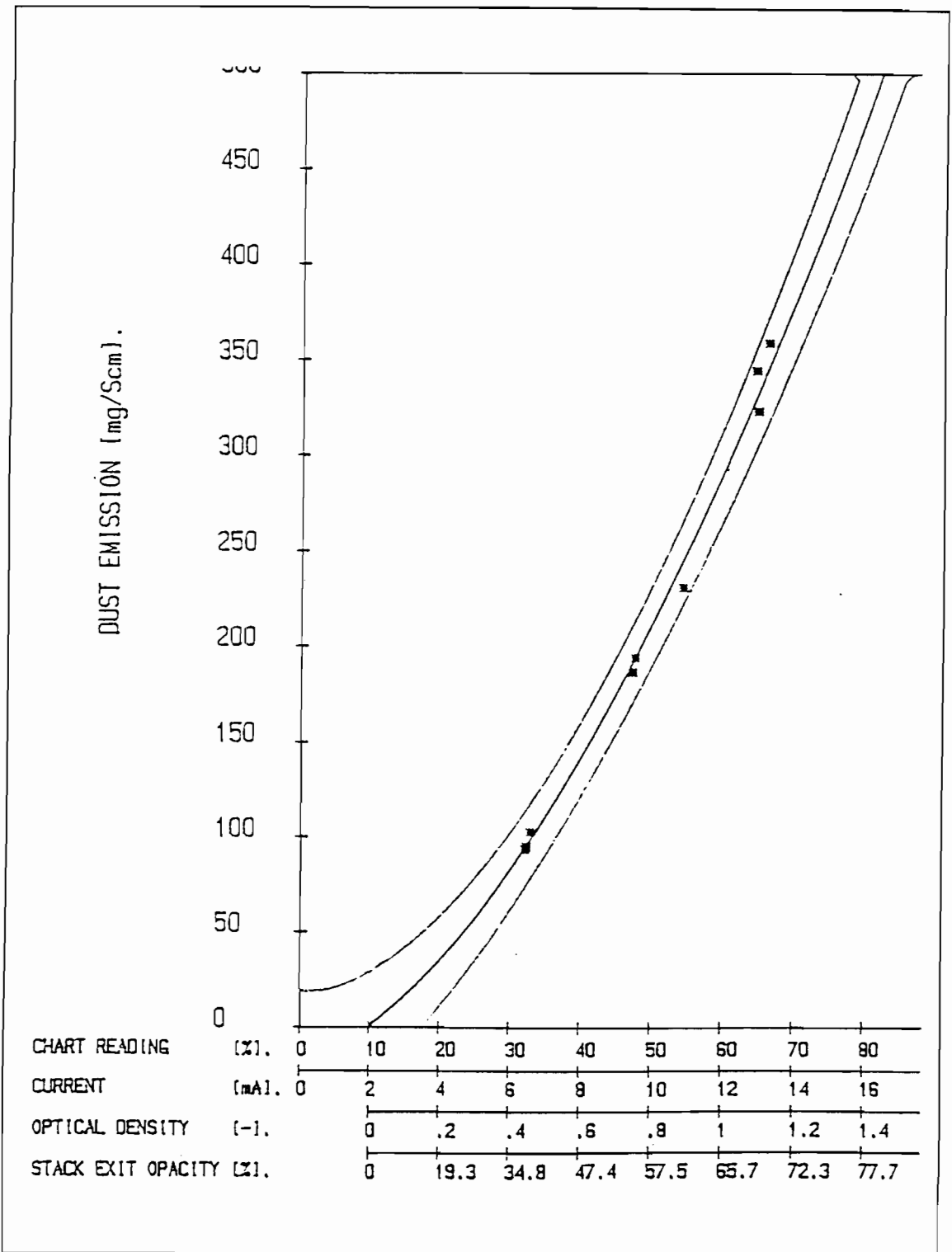

The present environmental legislation in South Africa is based on two requirements:

- The total station mass emission per 31 days should not exceed 1200 tons of particulate emissions (ash), i.e. 200 tons per boiler.

- An opacity of 60 % (250 mg/m³ STP) may not be exceeded for more than 8 hours. Thereafter the specific unit should be deloaded to bring the opacity below the limit.

The above legislation is based on a correlation curve⁽¹¹⁾ which shows the relationship between percentage opacity and mass emission (Figure 3.38). A separate correlation curve is available for each individual unit at Lethabo Power Station.

The importance of the precipitators and the mass emission legislation is the limitation that it can place on combustion air flow. The overall unit efficiency will be the main criterion, but the above emission limits can place an overruling restriction on any specific air flow recommendation. This will be of particular significance at higher loads.