

The effectiveness and advantages of an energy-efficient concrete mixer drive using a synchronous permanent magnet motor to develop helical rotor movement.

A permanent magnet motor with two degrees of mechanical freedom

by Dr. Oleksandr Dobzhanskyi and
Dr. Rupert Gouws, North-West University

Concrete production technology is a complicated process and electric power is used in almost every stage of concrete preparation. One of the most energy consuming stages is when the concrete is mixed in concrete mixers. There are many techniques proposed in literature on how to make concrete mixers more efficient through control applications [1, 2, 3, 4]. Most of these papers are, however, not concerned with electric motors which drive the mixers.

Mechanical power of the mixer blades is developed by the electrical drive connected through a gear or directly to the shaft where the blades are attached. The electric drive efficiency is therefore important for the energy consumption of the concrete plant.

The issue of permanent magnet machines versus induction motors for concrete mixers is well-debated. Some concrete mixer producers [5] suggest applying permanent magnet machines which usually have higher power density and efficiency, but also higher cost. Induction machines still dominate in the concrete production process.

This article introduces a novel design for a permanent magnet drive for concrete mixers. The proposed motor's high efficiency and simple structure promise energy savings and lower cost advantages. The motor is not a

conventional synchronous permanent magnet motor and the machine is designed so that two degrees of mechanical freedom (TDMF) of the rotor is achieved by the magnets skewed on its surface. In other words, the rotor of the machine moves helically (rotary and liner movements are combined).

There are various designs of electric machines with TDMF already proposed in literature, but most of them are induction or reluctance types of motors [6 – 9]. L Chen et al [10] have designed a permanent magnet motor with TDMF. However, there are two windings (rotary

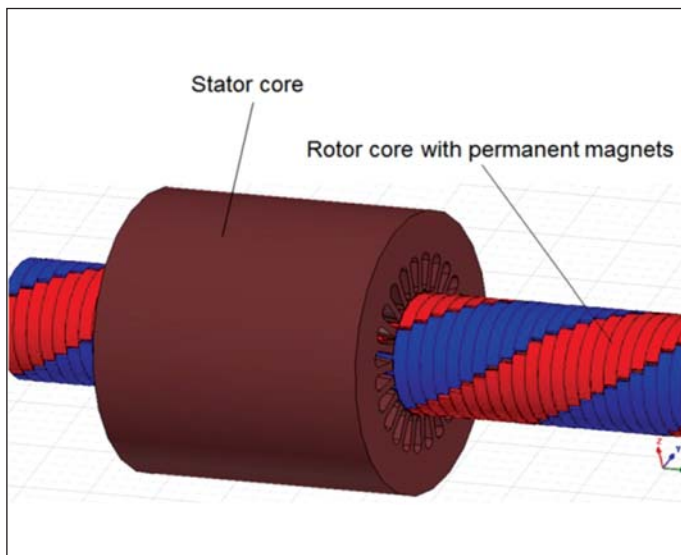

Fig. 1: The motor with TDMF.

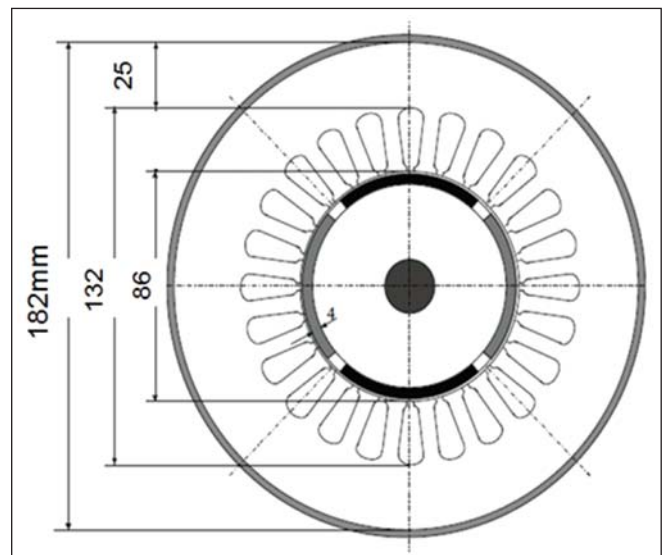

Fig. 2: Stator and rotor dimensions of the machine.

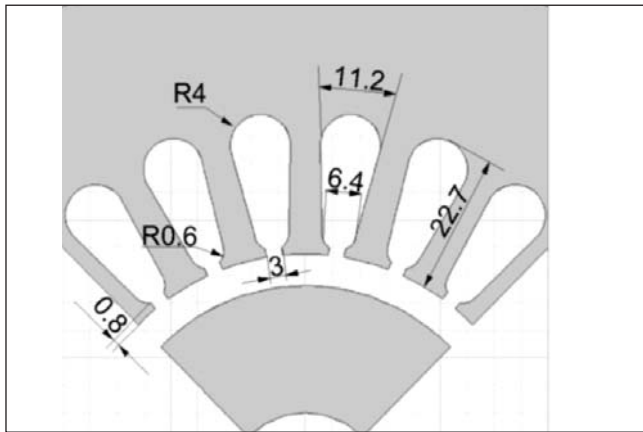

Fig. 3: Detailed stator slot dimensions.

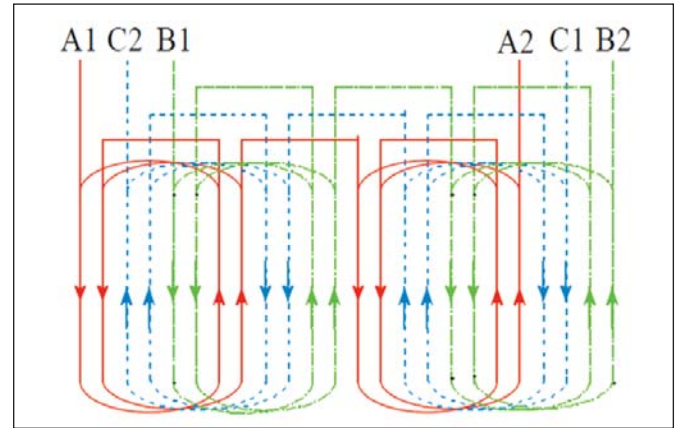

Fig. 4: Rotary winding diagram.

and linear) placed in one stator, which can cause mutual inductance between them. Shuang Ye et al introduce a synchronous permanent magnet drive for chaotic mixing [11], but chaotic movement of the compound is achieved by geometrically asymmetric design of the mixing tank.

Design description

The machine is shown schematically in Fig. 1, which shows the stator core and the rotor of the proposed machine. The rotor, placed inside the stator, is able to move axially and rotary. The rotor consists of the rotor core made of solid iron, and permanent magnets mounted on its surface. The permanent magnets on the rotor are skewed by six tooth pitches (twelve slots). The design of the proposed motor is similar to that of a conventional permanent magnet synchronous machine. Its dimensions were calculated to meet the required power at rated speed. The motor was analysed by means of 3D FEM software after the dimensions were determined. During the analysis, the dimensions were optimised to satisfy admissible values of magnetic flux density distribution in the stator and rotor cores. The basic dimensions of the motor are shown in Fig. 2.

The dimensions of the single slot are determined by the area needed to pack 72 conductors of AWG 16 wire. These dimensions are presented in Fig. 3. The rotary winding of the machine is a 3-phase overlap winding distributed in the slots according to the scheme shown in Figs. 4 and 5. The motor magnet, winding, and basic dimensions data is provided in Table 1.

Principle of operation

The motor's cross-section is shown in Fig. 6. The rotary 3-phase winding placed in the stator slots produces rotating magnetic field in the air-gap. The rotating magnetic field moves at speed. Interacting with the magnetic flux of the permanent magnets, the force (F) acting on the rotor is developed. This force is perpendicular to the magnet line as shown in Fig. 7. The force (F) can be split into two components – rotary (F_r) and linear (F_l). If the rotary magnetic field rotates in the opposite direction, the liner force will change its direction to that direction too. The machine can therefore produce helical movement on both axial directions: to the right and to the left. The rotor movement's trajectory is shown in Fig. 8.

Application: industrial concrete mixer

The motor design allows for blades to be attached to its shaft directly, without a gear. The blades' moving trajectory will

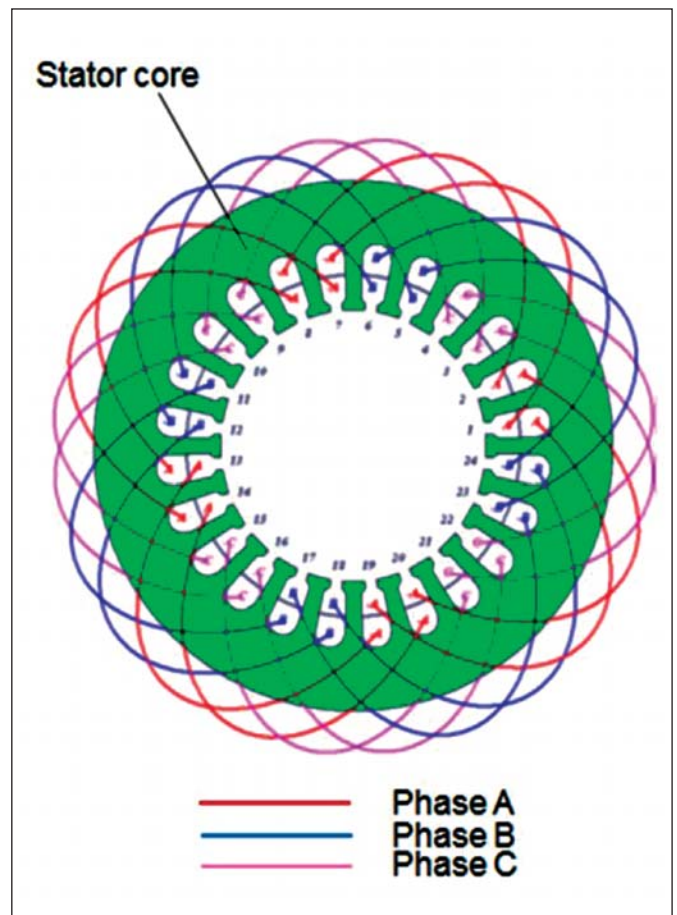

Fig. 5: Three-phase overlap winding distribution in the slots.

therefore also be helical. A schematic picture of the concrete mixer with TDMF drive is shown in Fig. 9.

The motor is placed between two mixing drums containing concrete compound. Two iron bars holding the mixer blades are attached firmly to the rotor yoke on both sides. The blades travel helically through the compound. When the rotor with permanent magnets approaches the mixing drum, the supply voltage direction is switched to the opposite, causing the rotor to "go backwards". The concrete compound in both mixing drums is mixed in this process.

Since the mixer produces rotary and liner moves at the same time, the blades design can be much simpler. Very often in conventional concrete mixers with only rotary movement of the rotor, blades have complicated shapes. Moreover, two

shafts with blades are used. Each of the shafts is driven by a separate motor. Such a complicated design is done to embrace a maximum amount of concrete compound during mixing. Fig. 10 shows the design of the conventional two-shaft concrete mixer used in the industry [12].

Another advantage of the proposed mixer is that it is direct-driven, meaning that no mechanical power is lost in gears and chain/belt mechanisms. This increases the efficiency of the process and decreases cost. Most conventional industrial mixers have gear mechanisms to transmit mechanical power from the rotor to the mixing blades. Mechanical power in gears is lost mainly due to the friction between gear teeth. Chains and belts dissipate power through stretch and wear and through friction. The total mechanical losses of gear mechanisms can reach more than 5%. Gear and chain mechanisms also increase maintenance on industrial concrete mixers. Fig. 11 shows an industrial concrete mixer with a gear and chain mechanism [5].

Efficiency analysis

The introduced motor with TDMF was designed to meet the following criteria:

- Rated power: 5 kW.
- Rated speed: 2500 rpm.
- Electromagnetic torque: 28 Nm.
- Linear force: 800 N.

An induction motor with similar output power, rated speed and torque was chosen to compare the motor with a conventional drive used in industrial mixers.

Winding	
Number of phases	3
Number of poles	4
Number of slots per pole per phase	6
Number of wires per slot, Nw	0,5
Filling factor, kW	AWG16
Permanent magnets	
Type	NdFe40
Relative permeability	1,09967
Bulk conductivity, S/m	625 000
Basic dimensions	
Stator diameter, mm	182
Rotor diameter, mm	86
Length of the armature, mm	100

Table 1: Design data of the machine.

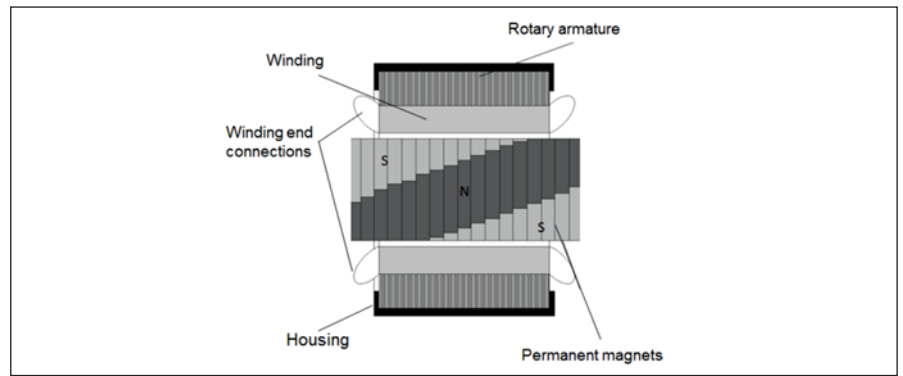

Fig. 6: Motor cross-section.

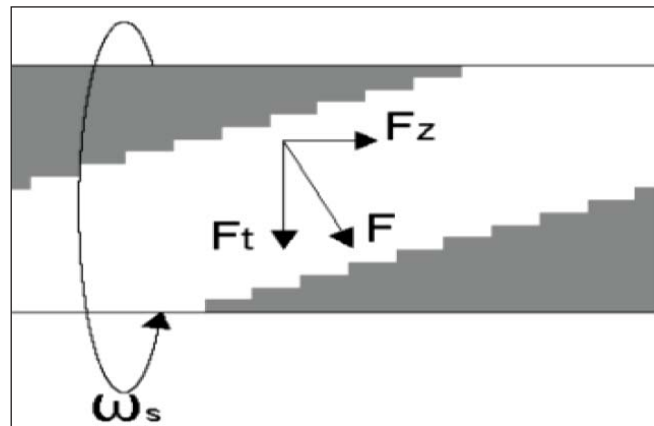

Fig. 7: Forces acting on the motor.

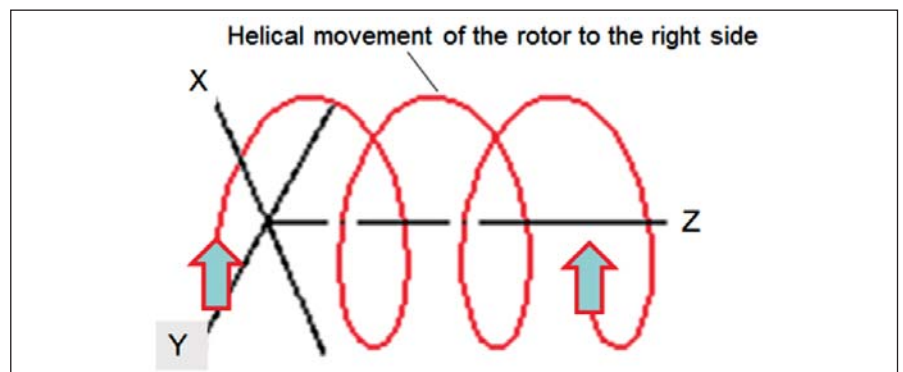

Fig. 8: Trajectory of the rotor movement.

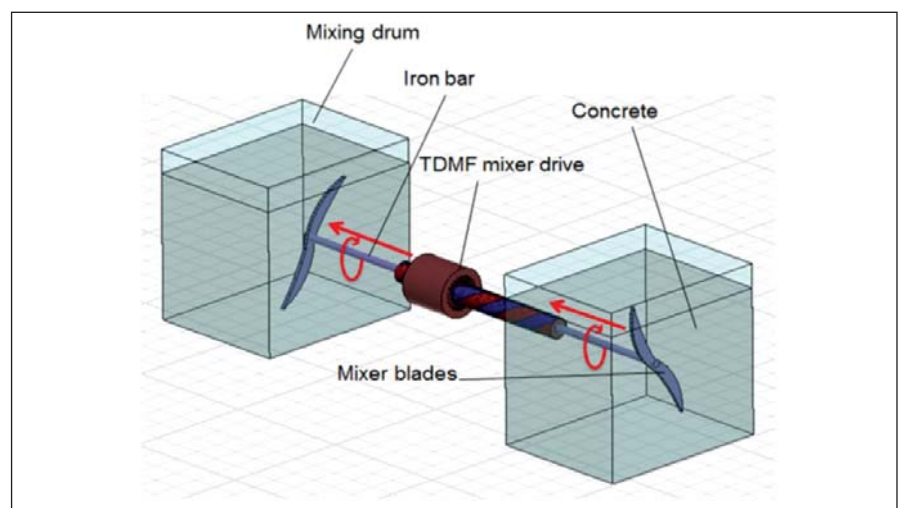

Fig. 9: Schematic illustration of the concrete mixer using the TDMF drive.

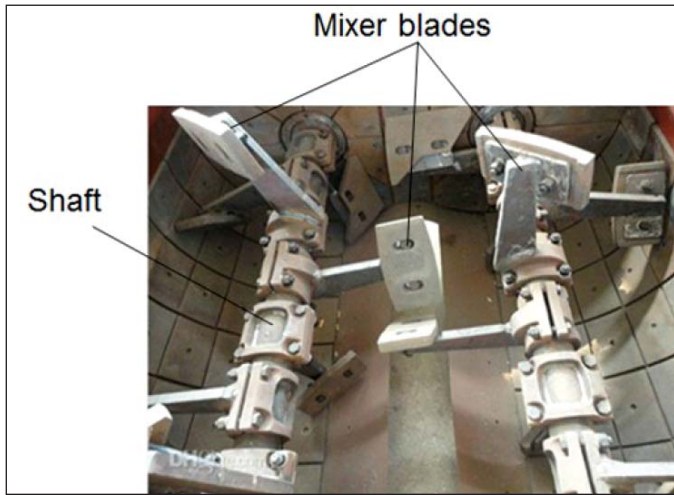

Fig. 10: Design of the industrial concrete mixer.

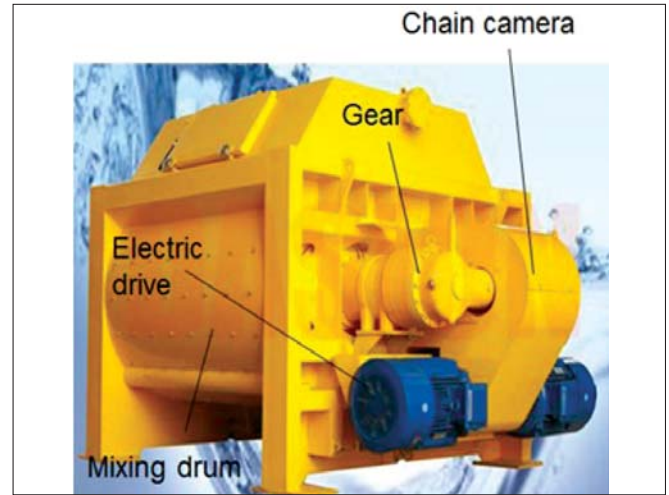

Fig. 11: Industrial concrete mixer with a gear-and-chain mechanism.

The parameters of the induction motor are as follows:

- Rated power: 5 kW.
- Rated speed: 2500 rpm.
- Electromagnetic torque: 32 Nm.

Both machines can provide the same power at rated speed for a concrete mixer. Two motors were compared in terms of efficiency, at different load conditions. The comparison was done to verify the energy use by both machines. Energy consumed by an electric motor depends on three factors: operating hours, load and efficiency. The relationship between them is calculated as follows [13]:

$$\text{Energy consumption} = \frac{\text{operating hours} \cdot \text{load}}{\text{efficiency}} \quad (1)$$

This equation demonstrates that, the higher the level of efficiency, the lower the energy consumption of the motor. The efficiencies of both machines are shown in Fig. 12.

The efficiency of the TDMF motor at full load is 94%; the efficiency of the induction motor is close to 87%. The dashed area between the two curves represents how much more energy is consumed by the induction motor.

Conclusion

A 3-phase permanent magnet motor with two degrees of mechanical freedom was designed to be used in industrial concrete mixers. Electromechanical parameters such as output power, rated torque and linear force were calculated using 3D FEM software. The advantages of the proposed motors are simple design, helical rotor movement and the ability to connect blades directly to the rotor.

The machine was compared with a conventional induction type drive for

industrial concrete mixers and the efficiencies of both motors were calculated and compared. The results show that the induction motor was less efficient than the permanent magnet machine.

Acknowledgment

This article is based on a paper presented at the 2013 Industrial and Commercial Use of Energy Conference and is republished here with permission.

References

- [1] L Ming-shan, Z Yuan: "Application of artificial intelligence technology in asphalt concrete mixer control systems", fourth International Conference on Fuzzy Systems and Knowledge Discovery, Volume 4. pp 159 – 163, 2007.
- [2] H Da-young, Y Ju-qing: "Design of distributed computer control system based on the fieldbus for asphalt concrete mixer", International Conference on Computer Applications and System Modelling (ICCSM), Volume 15, pp 587 – 591, 2010.
- [3] RB Williamson: "Electric motors in the cement industry", American Institute of Electrical Engineers, Volume: XXXVII, Issue: 2, pp 1531 – 1650, 1918.
- [4] J Zhao, L Xinhui, Z Xin, Y Han: "Research on the energy-saving technology of concrete mixer trucks", fourth IEEE Conference on Industrial Electronics and Applications, pp 3551 – 3554, May 2009.
- [5] Dasion Company: "YJS series twin-shaft concrete mixer", 2013. Available online: www.da-sion.net/mixer/3.html
- [6] J Fleszar, E Mendrela: "Twin-armature rotary-linear induction motor", IEEE PROC., Volume 130, Pt. B, #3, pp. 186-192, May 1983.
- [7] EA Mendrela, E Gierczak: "Double-winding rotary-linear induction motor", IEEE Transactions of energy conversion, Volume EC-2, #1, pp. 47-54, 1987.
- [8] JF Pan, NC Cheung, G Cao: "A Rotary-linear switched reluctance motor", third International Conference on Power Electronics Systems and Applications, 2009.
- [9] T Mashino, S Toyama: "Micro rotary-linear ultrasonic motor for endovascular diagnosis and surgery", 2008 IEEE International Conference on Robotics and Automation, Pasadena, CS, USA, pp. 3600 – 3605, 19 – 23 May 2008.
- [10] L Chen, W Hofman: "Design of one rotary-linear permanent magnet motor with two independently energised 3-phase winding", International Conference on Power Electronics and Drive Systems, pp. 1372 – 1376, 2007.
- [11] Y Shuang, KT Chau: "Design of permanent magnets to chaoize PM synchronous motors for industrial mixers", Digest of the IEEE International Magnetic Conference, pp: 723 – 724, 2005.

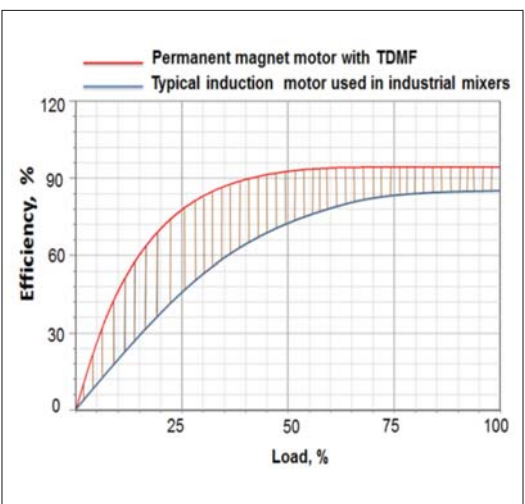

Fig. 12: Efficiency curves of permanent magnet motor with TDMF and typical induction motor at different load conditions.

Contact Dr. Rupert Gouws,
North-West University,
Tel 018 297-5908,
rupert.gouws@nwu.ac.za