

Evaluation of generator circuit breaker applications

J.F. Fourie

12425044

**Dissertation submitted in partial fulfilment of the
requirements for the degree Master of
Engineering in Electrical Engineering at the
Potchefstroom campus of the North-West
University**

Supervisor: Prof J.A. de Kock

June 2010

Abstract

The use of generator circuit breakers in power stations was investigated and evaluated. A feasibility study to determine if the additional capital cost required, when using a generator circuit breaker in a power station could be justified by the advantages it provides.

The background to the study is provided through a technology and literature survey. Included in the technology review and the literature study is information on interruption mediums, the historic developments of circuit breakers and generator circuit breaker application theory. This data was used to determine the practicality of using a specific interruption medium within a generator circuit breaker application. The requirements of generator circuit breakers were determined and used to evaluate the interruption mediums in question.

To ensure practical results, commonly used layouts were used to determine the effect of using a generator circuit breaker on the reliability, availability and the mean time to repair of a power station electrical distribution layout. Furthermore, the effect of the protection on the generator and generator transformer was evaluated. It was found that increased selectivity of the protection system by using a generator circuit breaker limits the extent of equipment damage in case of failure.

Practical layouts were used to determine the effect on reliability. The analysis was conducted using assumed values of operational costs to determine the cost incurred through the change in reliability of the power station. By adding a generator circuit breaker, the station transformer and associated equipment is regarded as back-up or redundant equipment. This increases the reliability of the power station dramatically and limits the risk of income lost due to failures.

The full evaluation included the estimation of the capital investment costs and the impact that the additional cost has on the operational requirements of a power station. The study determined that the capital cost required to use a generator circuit breaker results in no additional income for a power station. Through the increased protection, higher availability and the possible omission of power station ancillary equipment, the use of generator circuit breakers will result in more power being delivered and more income generated by a power station.

The study proved that the generator circuit breaker is a critical part of a power station layout and is a necessary capital requirement to ensure the sustainability of the power station.

Key Words: Generator circuit breaker, power station layout, reliability, circuit breaker, protection

Declaration of Originality

I declare that this dissertation is a presentation of original research by me, conducted under the supervision of Prof. J.A. de Kock. Whenever contributions of others are involved, every effort is made to indicate this clearly, with due reference to the literature. No part of this research has been submitted in the past, or is being submitted, for a degree or examination at any other University.

.....
JF Fourie

June 2010

Table of contents

Abstract	ii
Declaration of Originality	iv
Table of contents	v
Table of figures	vi
List of tables	viii
Chapter 1: Introduction	1
Chapter 2: Technology Review	4
2.1 NEED FOR CIRCUIT BREAKERS.....	5
2.1.1 Arc Phenomenon	7
2.2 TYPES OF CIRCUIT BREAKERS.....	9
2.2.1 Air Circuit Breaker.....	10
2.2.2 Oil Circuit Breakers.....	20
2.2.3 Vacuum.....	25
2.2.4 SF ₆	35
2.3 <i>CIRCUIT BREAKER OPERATING MECHANISMS</i>	42
2.3.1 Opening Requirements	43
2.3.2 Closing Requirement	46
2.4 SUMMARY	49
Chapter 3: Generator Circuit Breaker Literature Review	52
3.1 GENERAL REQUIREMENTS OF GENERATOR CIRCUIT BREAKERS	52
3.2 GENERATOR CIRCUIT BREAKER.....	56
3.3 GENERATOR OPERATION MODES	60
3.4 BASICS OF GENERATOR STATION PROTECTION	64
Generator Protection	64
Transformer Protection.....	67
3.5 SUMMARY	70
Chapter 4: Impact Analysis	72
4.1 SIMULATION.....	73
4.2 POWER STATION LAYOUTS.....	79
4.3 SYSTEM AVAILABILITY AND RELIABILITY	88
4.4 COST CALCULATIONS.....	96
4.5 SUMMARY	99
Chapter 5: Conclusion	101
References	104

Table of figures

Figure 1: Single line diagram of practical power station [19]	2
Figure 2: Voltage variation in failure modes of circuit breakers [2]	8
Figure 3: Main parts of an air circuit breaker [2]	11
Figure 4: Graphic operation of a magnetic circuit breaker with a blow out coil a) Normal current carrying, b) Initial contact separation, c) Current transferred to arcing contacts and electro magnetic coil inserted into the system, d) Coil assist in the arc continuing into the runners [3]	14
Figure 5: Basic operations of air blast circuit breaker operations [4]	15
Figure 6: A graphical representation of a conducting single flow nozzle [3]	16
Figure 7: Pressurized-head air blast circuit breaker [3]	17
Figure 8: Schematic diagram of an air generator circuit breaker [8]	20
Figure 9: Original Oil Circuit Breaker Design [3]	21
Figure 10: BOCB with side vented arc control device [2]	22
Figure 11: Representation of 36 kV MOCB [2]	24
Figure 12: Vacuum Circuit breaker commissioned in the U.K. in 1967 [6].	27
Figure 13: Schematic diagram of the typical components of a vacuum circuit breaker [2].	28
Figure 14: Basic Components of a vacuum circuit breaker [6]	28
Figure 15: Representation of voltage conditioning in vacuum interrupters [5].	32
Figure 16: Photograph of a SF ₆ circuit breaker [2]	37
Figure 17: Schematic representation of the arc quenching mechanism of a SF ₆ circuit breaker: a) normal current carrying operation, b) current breaking is initialised and only arc contacts used to carry current, c) arcing between moving arc contacts and fixed contact, forced gas movement by the double piston self pressurized principle, d) interrupted current complete or open position [2].	38
Figure 18: Representation of the single and double puffer interrupters [2]	40
Figure 20: Schematic representation of an integrated generator protection system [9]	41
Figure 21: Contact material erosion due to arcing [3]	45
Figure 22: Graphic demonstration of the basic parts of a spring type mechanism [2]	47
Figure 23: Pneumatic mechanisms [2]	48
Figure 24: A finger of a segmented arcing contact system [9]	57
Figure 25: Voltage escalation due to restrikes during capacitive load switching [3]. Note: E is used for voltage is this graph.	61
Figure 26: Voltage surges (p.u.) per time unit caused by consecutive re-strikes while interrupting inductive currents [3]	63
Figure 27: Stator Differential protection [13]	65
Figure 28: Configuration of transformer differential and restricted earth fault protection	69
Figure 29: Generation station layout	75
Figure 30: Voltage output of the simulated generator without a generator circuit breaker	76

Figure 31: Simulated fault current without a generator circuit breaker installed	76
Figure 32: Generator terminal voltage with generator circuit breaker installed	77
Figure 33: Simulation outputs of fault currents with a generator circuit breaker	78
Figure 34: Directly connected generator with generator circuit breaker	80
Figure 35: Layout of a thermal power station without a generator circuit breaker	81
Figure 36: Pointer diagrams of the automatic transfer algorithms used in HBT [14]	82
Figure 37: Layout of a generating station with a generator breaker included	83
Figure 38: Visual comparison of the difference between Gas turbine power station layouts without and with a generator circuit breaker	84
Figure 39: Graphical representation of Layout 1 in table 11	94
Figure 40: graphical representation of Layout 2, 3 and 4 of table 11	95

List of tables

Table 1: Example of technical specifications of an air blast generator circuit breaker [8]	19
Table 2: Strengths and weaknesses of vacuum as an arcing medium [5].	34
Table 3: Mechanical duty requirement of circuit breaker operating mechanisms class M1	43
Table 4: Characteristics of Circuit Breaker operating mechanisms [2]	48
Table 5: Comparison between requirements of circuit breakers [11]	59
Table 6: Summary of comparative layout table results	86
Table 7: Summary of the data used from the IEEE Std 493-1990 [16]	90
Table 8: Summary of data used to evaluate layouts with generator circuit breakers	91
Table 9: Results of failure rate comparison between figure 35 and 37	92
Table 10: Results of unit configuration of two parallel units with and without generator circuit breakers	93
Table 11: Results comparison between layout availability for production	94
Table 12: Summary of budget quotations for power station equipment	98
Table 13: Summary of costing data for all evaluated solutions	100

Chapter 1: Introduction

A circuit breaker is "a mechanical device capable of making, carrying and breaking currents under normal circuit conditions and also making, carrying for a short time and breaking currents under specified abnormal circuit conditions such as those of short-circuits" [1]. The definition describes a circuit breaker's purpose in an electrical circuit. For this specific reason, this device has been used and applied in most electrical circuits for more than a century. This investigation will focus on a special type of circuit breaker, the generator circuit breaker. This circuit breaker can be classified as a high voltage / high current circuit breaker applied in a special medium voltage environment. The circuit breaker is applied in the circuit directly between the generator and the generator (step-up) transformer as can be seen in Figure 1. In Figure 1 the square represents the generator circuit breaker and the x represents possible fault locations within the system.

The aim of this investigation is to determine through technology, literature and calculations the feasibility of using generator circuit breakers in modern power stations.

The study was conducted to discuss various viewpoints on the use of generator circuit breakers. The viewpoints are divided as the increase in capital cost required to use a generator circuit breaker are compared to the improved benefits in system protection, reliability and availability of a power system. Advantages in protection are documented and more often than not the reason for the inclusion within modern power stations. A comprehensive study to determine the impact on layout, reliability and cost is required. The mentioned aspects are directly affected by the inclusion of a generator circuit breaker, and serves as the motivation for this study. Previous studies conducted on generator circuit breaker were conducted based on the equipment risk and the financial implications of possible failure. This study bases financial estimations on the variations in capital and running costs as this can accurately estimate financial impacts throughout differences in configuration and layout.

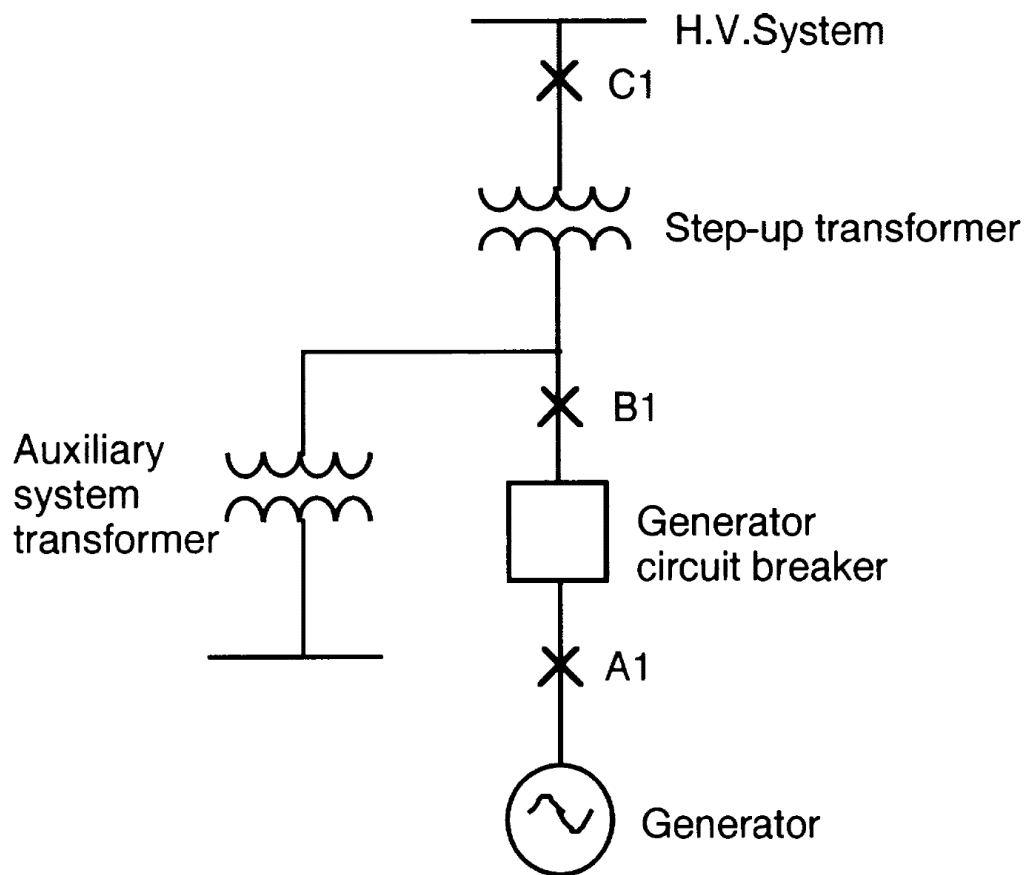

Figure 1: Single line diagram of practical power station [19]

Through multiple practical evaluations and theoretical simulations, the feasibility of using a MV generator circuit breaker within various layouts was determined. Furthermore, the study aims to cement the generator circuit breaker as either a critical or optional component in modern power stations.

To ensure that all possible impacting elements on generator circuit breakers are considered, all aspects that effect reliability, protection, and practical use must be considered. For this reason the study was based on a technology review of circuit breaker technologies, to determine the limitations and their impact, a literature review of generator applications and the complexity thereof. Furthermore, the associated protection system theory is evaluated to develop an insight in some practical requirements of generator circuit breaker

applications. The report does not practically determine the magnitude of fault conditions and the response of the breaker. The protection settings and co-ordination thereof is also not included in this text.

This study includes an economic analysis and the techniques used to evaluate power station reliability and mean time to repair. These tools can also be used to determine the most economical power station layouts.

The installation of a generator circuit breaker is simply the improvement of the protection of a power station generator and associated equipment. This can only be achieved at a price that is determined by the type, size and incorporated devices in the generator circuit breaker. This circuit breaker also results in possible additional changes within the power station layout, additional capital cost and the reliability of the layout. In this investigation these questions and the interaction of various elements will be quantified and evaluated, resulting in a practical layout of a power station. The effect of the using of a generator circuit breaker will finally be determined by the comparison of the layouts with and without a generator circuit breaker using the cost, reliability and availability of the system as criteria.

Chapter 2: Technology Review

This chapter's primary purpose is to evaluate and develop an insight into circuit breaker technology and protection theory. This information is required in later chapters when evaluations and simulations using generator circuit breakers are done. Further detail of circuit breaker technologies was required as they dictate the feasibility of implementation within any specific power station layout. By discussing the limitations and use of circuit breakers within a power station, the impact on the design, layout and reliability can be evaluated. The advantages and restrictions of each type of breaker can be used to determine the optimal application, and this can affect the reliability of the power station. This also effects the cost of the power station as the size, type, mechanism, and associated requirements of a generator circuit breaker determines multiple factors of the station as a whole.

The types of breakers that were evaluated are all currently available technologies or technologies that are used in field applications. This necessitates a review of these technologies. Operating mechanisms are briefly discussed as they influence the advantages and disadvantages of breaker technologies, such as the speed, contact corrosion and auxiliary requirements of mechanisms.

All the mentioned factors were evaluated to create a complete picture of the function and restrictions of circuit breakers in generator circuit breaker applications. This in turn directly affects the power station as a whole in terms of possible availability, reliability, economic sustainability, and initial capital costs. In the sections to follow a complete review of these aspects are discussed and the theoretical evaluation of the need for and the practicality of implementing circuit breakers as generator circuit breaker were reviewed.

2.1 NEED FOR CIRCUIT BREAKERS

Circuit breakers are a necessary part of any power system. This is due to the possibility of fault conditions occurring at any time. In the following section the various types of faults as well as conditions of faults will be discussed. This background of power system protection devices and systems is essential as an in-depth knowledge of the possibilities of faults and the conditions in which they occur can prevent costly interruptions or equipment failures or both. The most common of all system faults is the occurrence of a system using or supplying more current than the equipment within the system can handle, also called an overcurrent event. Overcurrent conditions can be explained as a dramatic rise of current when a fault occurs. Any load needs some current for correct operation, but if the rated current is exceeded it is described as an overcurrent condition.

To protect equipment against faults fuses and circuit breakers can be used. These types of equipment incorporate some form of delay in operation at lower intensity faults. This is done for various reasons, including allowing controllable overloading of equipment and to ensure proper grading between power system equipment. This is important as it ensures that only the faulty section is isolated. One of the fault conditions that causes severe overcurrent conditions is short-circuits. As the name suggests, this fault occurs when a section of a circuit is eliminated, thus reducing the load impedance dramatically. This will cause dramatic changes in the current. The extreme overcurrent can be damaging to equipment. The protection should thus be sufficient to limit the energy within such a fault by reacting to the condition in a short time. All alternating current (ac) power systems incorporate components that can store limited amounts of energy naturally. This energy discharge can result in a direct current (DC) component that is superimposed on the ac fault current. This energy discharge decays with time according to the X/R ratio of the system. But just how intense can such a short-circuit fault be? A short-circuit fault is restricted by the maximum capacity of the voltage sources and the system impedance. Possible voltage sources include generating stations and all rotating machines running at the time of the fault.

In extreme cases, a source can be an external factor such as lightning that strikes a system.

Another consideration in a modern power station is the critical requirement of continuously supplying power to the network. This complicates the protection, as only the fault-affected area should be isolated. The network as a whole should be capable of handling various fault conditions and still supply much needed power to consumers. This also complicates the design of power systems, as sections of the power system are prone to exposure to fault conditions.

Various types of short-circuit faults can occur, for example single phase-to-earth, phase-to-phase faults, and balanced three-phase faults. To ensure that all possible conditions are accounted for, the worst-case scenario must be considered. In general the balanced three-phase fault could cause the most damage, thus the power system protection co-ordination is calculated using these fault levels.

Because rotating machines are one of the most common circuit elements within an end-user system, their effect on power system faults have to be evaluated. Three-phase rotating machines cause the ac component of the fault current to change with time, and these rapid variations of generator and motor impedance are caused by the change from subtransient to transient and synchronous reactance. To explain the effect of this varying reactance, its use and time boundaries will be described. Subtransient reactance is usually used to calculate the instantaneous values of fault conditions and can usually be applied to the first 40 ms of the fault, thereafter the transient reactance should be used until the steady state value is reached. The synchronous reactance can be used to calculate the steady state fault current and associated protection relay settings.

The fault power factor also influences the fault current behaviour. A power factor of one can result in efficient interruption of fault current. This is because only the resistive components have an impact on fault conditions, and limits

the possible damage to the circuit breaker contacts. On the other hand switching in low power factor conditions has the opposite effect. Damage to circuit breaker contacts and arc extinguishers are extensive, and the interruption of the current is more complex.

For a successful current interruption some requirements have to be met, i.e. to ensure that the arcing is limited, the power dissipated in the arcing process must be less than the breaker's cooling capacity. The breaker's interruption medium should also have a high de-ionisation rate and adequate dielectric strength. For this reason, the internal functioning of a circuit breaker must be understood and will be explained in the sections to come. The breaker interruption medium, method of arc formation and interruption are critical factors in understanding the methods of disconnecting system sections or components.

2.1.1 Arc Phenomenon

The arcing between current carrying contacts, separated by some mechanism, is one of the essential parts of the circuit breaker and can be modelled as a non-linear variable resistor [2]. "This variable resistance is a high pressure arc that burns in a corresponding gas in various circuit breaker mediums such as air, oil and SF₆" [2]. The exception to this rule is vacuum circuit breakers where the arc burns in electrode vapour.

In the opening process of a circuit breaker the arcing contacts plays a significant role in the prevention of the abrupt interruption of the current. The arc provides a low resistance path after contact separation and so minimise the current chopping and transient recovery voltages. In an alternating current circuit breaker the arc is momentarily extinguished at every current zero, thus for current breaking to occur the arc should be prevented from re-igniting after voltage is re-established. The arc phenomenon is a requirement for the operation of the circuit breaker and the lack thereof can cause dramatic damage to the breaker and other circuitry. Through the prevention of the arc, the current interrupts instantaneously and the collapse of the magnetic field will cause very high voltages in the insulation system [2]. This

creates the need for efficient arc control mechanisms to obtain the best functional current interrupter. Control can only be established once a clear understanding of the electrical characteristics of an electrical arc is known.

In theory there is energy stored in the arc column [2], this means that the conductance will cross the zero threshold after the current zero has passed, meaning that 'post-zero' current has to flow. If the rate of rise of the recovery voltage is greater than the critical value, just after current zero, ohmic heating can cause the arc to re-establish. In this situation thermal failure can occur. The re-striking value can have a peak amplitude of such nature that the gap dielectric withstand fails.

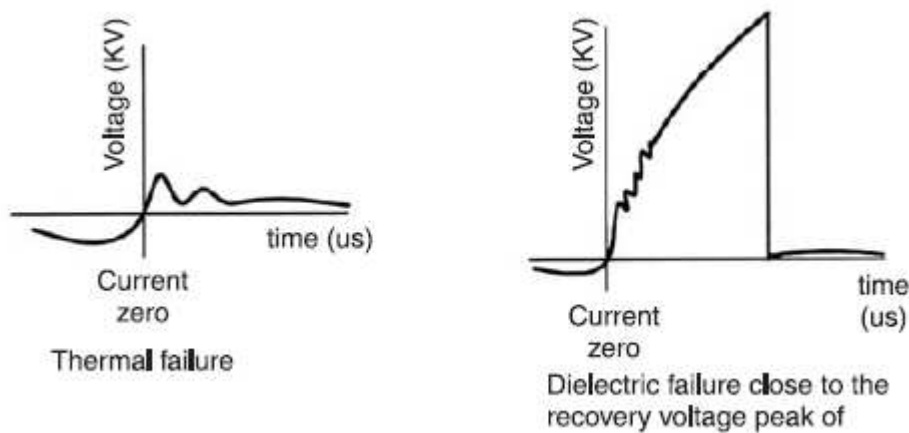

Figure 2: Voltage variation in failure modes of circuit breakers [2]

In Figure 2 the difference in the voltage over the circuit breaker can be seen for the two system failures as described in the preceding text.

The arcing process within the circuit breaker has one of two methods of occurring, by the ions neutralising the electric space charge and allowing large currents to flow [2]. The other occurs in ac circuit breakers when the arc is extinguished after every current zero, and re-strikes occur only if the transient recovery voltage across the electrodes reaches a sufficient value.

The primary function of the circuit breaker is to prevent the re-striking of the arc and this re-strike depends on factors such as the nature and pressure of arc, external ionising and de-ionising agents, voltage across the electrodes,

and variation of the voltage with time, material and configuration of the electrodes and the nature and configuration of the arcing chamber. Arcs can be classified in two categories, visual high-pressure arcs and vacuum arcs [2].

In visual high-pressure arcs, the arc-quenching medium is a flowing gas, usually air or SF₆. High-pressure arcs are described in three distinct regions [2]:

- Cathode Region : Electrons and metal vapour are emitted from the metal electrode in the form of plasma
- Arc Coulomb : Current is carried by moving electrons and ions
- Anode Region : Electrons from the vapour enter the electrode and metal vapour enters the plasma

This previous section explained the functioning of a circuit breaker, concentrating on the forming and the operation of the arc within circuit breaker. Further, the different methods of quenching this arc will be described; this will be discussed in a forthcoming section, as there are many different methods of arc quenching.

2.2 TYPES OF CIRCUIT BREAKERS

During the development of electrical systems, the protection thereof had to develop accordingly. Through the major improvements in electronics the control, measurement and interpretation of electrical system states has become a precise science. This also relates to the development of circuit breakers of various sizes, applications and types. The section will describe the various types of breakers used practically. To ensure a full understanding of the possible applications the history, development, and the possible uses of generator circuit breakers are described. This section will establish sufficient background information for all breaking mediums used in circuit breakers. This background will be used to determine the advantages and disadvantages of each type, and from this the practicality of implementing the specific type in generator circuit breaker applications will be determined.

2.2.1 Air Circuit Breaker

“A circuit breaker, which opens and closes in air at atmospheric pressure” is described as an air circuit breaker [2]. Air circuit breakers (ACB), although one of the oldest forms of circuit breakers, are still being used today in low voltage applications and high security applications (generally used in locations which are at risk of fires and the consequence of oil contamination is too high) [2]. These types of breakers are applied as generator circuit breaker in applications where extremely high breaking capacity is required. The main parts of an ACB are shown in Figure 3.

Air at atmospheric pressure has a low dielectric strength, approximately 3 kV/mm depending on the contact surface. According to Garzon [3] still air has a large deionisation time constant due to the lack of an accelerant in the process of recombination. This explains the limited current breaking capacity of early knife type circuit breakers, and the need for further developments within this class. The development of the air circuit breaker and the adaptations to expand their usable voltage range will be explained in the next segment.

One of the earliest types of circuit breakers that operated in free air was the plain break knife switch type. Air circuit breakers have developed from the early nineteenth hundreds into various types of constructions and applications. Although used in multiple applications the development and optimisation of forced air-flow in the arcing chamber in the twentieth century is the defining innovation of this class of circuit breaker.

Patented in 1927 and commercially used in 1940s the air blast circuit breaker is one of the most successful of all air circuit breakers developed. This type of breaker was also the preferred and the only choice for voltage levels above 345 kV before the development of SF₆ breakers in the second half of the twentieth century [3]. In 1964 U.K. designs of air blast circuit breakers,

operating at 2.5 MPa with up to 12 breaks per phase, resulting in fault ratings of 35 000 MVA for system voltages up to 400 kV [4], were developed.

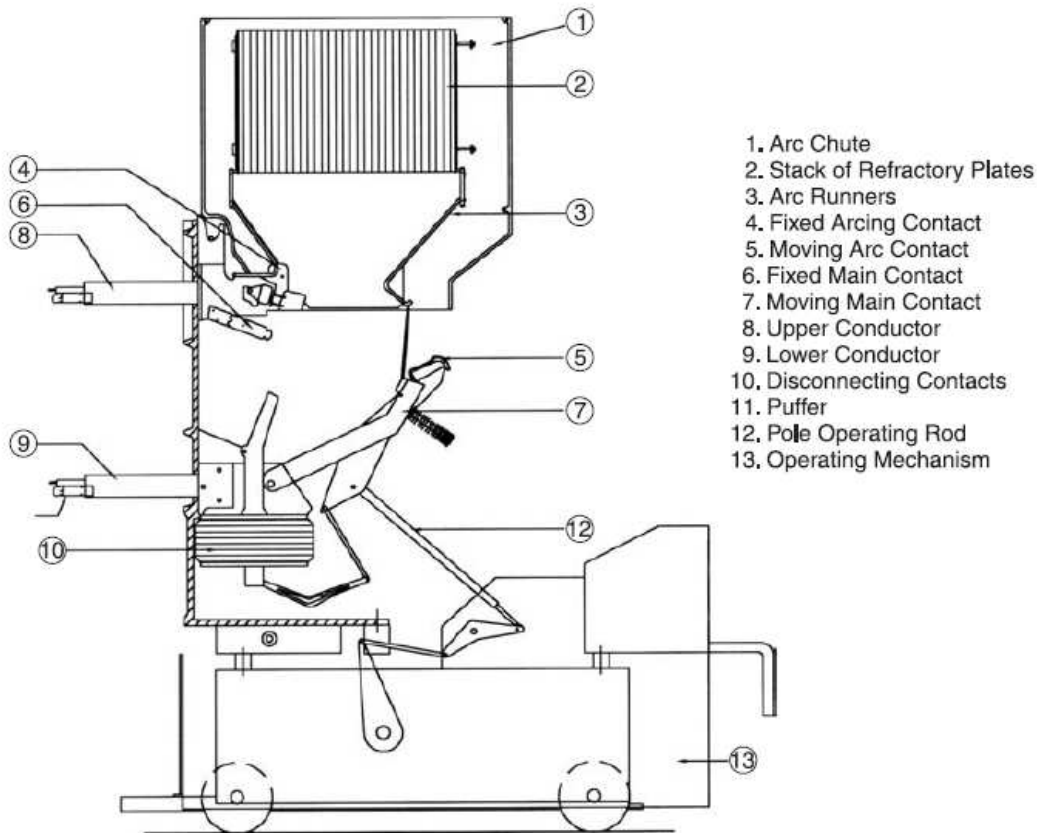

Figure 3: Main parts of an air circuit breaker [2]

In the USA and Europe, respectively air magnetic circuit breakers and air blast circuit breakers were the most common used breakers in the 1970s for medium voltage indoor applications [4]. During this time out-door applications within the high voltage range relied on the air blast breaking technology for fault interruption [3].

Another defining development within the air circuit breaker is the arc chute. This device that consists of a box with insulated metallic plates that lengthens the arc to assist in the interruption of the arc. This effectively aids in the cooling of the arc plasma and the deionisation is completed much faster. Deionisation of the air in the arc causes the resistance air gap to increase,

reducing the short-circuit current. This dramatically increases the possibility of a successful fault interruption [4].

It is also true that increasing the resistance of the arc increases the voltage across the arc, and within different types of air circuit breakers this is achieved by:

- a Lengthening the arc
- b Splitting the arc into multiple shorter arcs - shorter interruption times are possible when the number of short arcs voltage combined is higher than the system voltage [3].
- c Constricting the arc, through narrow channels, thus reducing the cross-section of the arc and increasing the arc voltage.

Most recent developments in this class of breakers are in the low voltage range and are omitted from this text. Further developments with the air blast type circuit breakers will be similar to the developments of SF₆ self-pressurized circuit breakers and puffer breakers. The detailed operation of each subgroup of air circuit breakers will now be discussed.

2.2.1.1 Air Magnetic Circuit Breakers

Air magnetic circuit breakers, for all medium voltage applications, rely on the arc chute as interrupting device, as mentioned earlier. This type of breaker is not generally used as generator circuit breaker, but can be used with small generators due to restrictions to be mentioned earlier.

This arc chute is made of insulated ceramic materials, for example, zirconium oxide or aluminium oxide [3]. The quenching of the arc is initiated by lengthening the arc. Through the design of the breaker, specifically the geometry and the position of the slits, the arc follows a complex path upwards [3]. On contact with the ceramic plates, the arc is constricted as the arc should now fill the narrow space between these plates, and is cooled by diffusion to these walls [3].

An arc can be compared to a flexible conductor that can be manipulated into these insulating plates. The forced movement of the arc can be achieved by an external magnetic field, usually produced by an electric coil. This coil is bypassed in normal operation by the arcing contacts as can be seen in Figure 4(a). In Figure 4(b) the current is transferred to the arcing contacts and on separation initiates the arc [3]. When the arcing contacts separate the geometry of the arc, runners force the arc into the chute simultaneously the coil is inserted into the circuit and forces the arc deeper into the chute (see Figure 4(d)). The arc rapidly transfers heat to the insulating plates, releasing gasses and vapour [3]. It must be noted that the forces of the arc and the magnetic coil on the vapour has to be larger than the downward force of the gasses [3]. This is a necessity, as the gas and vapour have to escape through an opening at the top of the arc chute. Contact with the opening contacts can result in re-strikes. Another requirement of the blow out coil is that a phase lag is needed to ensure that the force on the arc is not lost at current zero [3]. Although this technology is one of the oldest and most researched methods of current interruption the design of an arc chute remains an art and relies on experimentation for optimisation. To ensure the upward movement of the arc in most air magnetic circuit breakers, a puffer is used to force air through the separating arc contacts, to assist in the upward movement of the arc into the chute. This is needed because the magnetic force at low current levels can be too weak to aid in the upward movement of the arc [3].

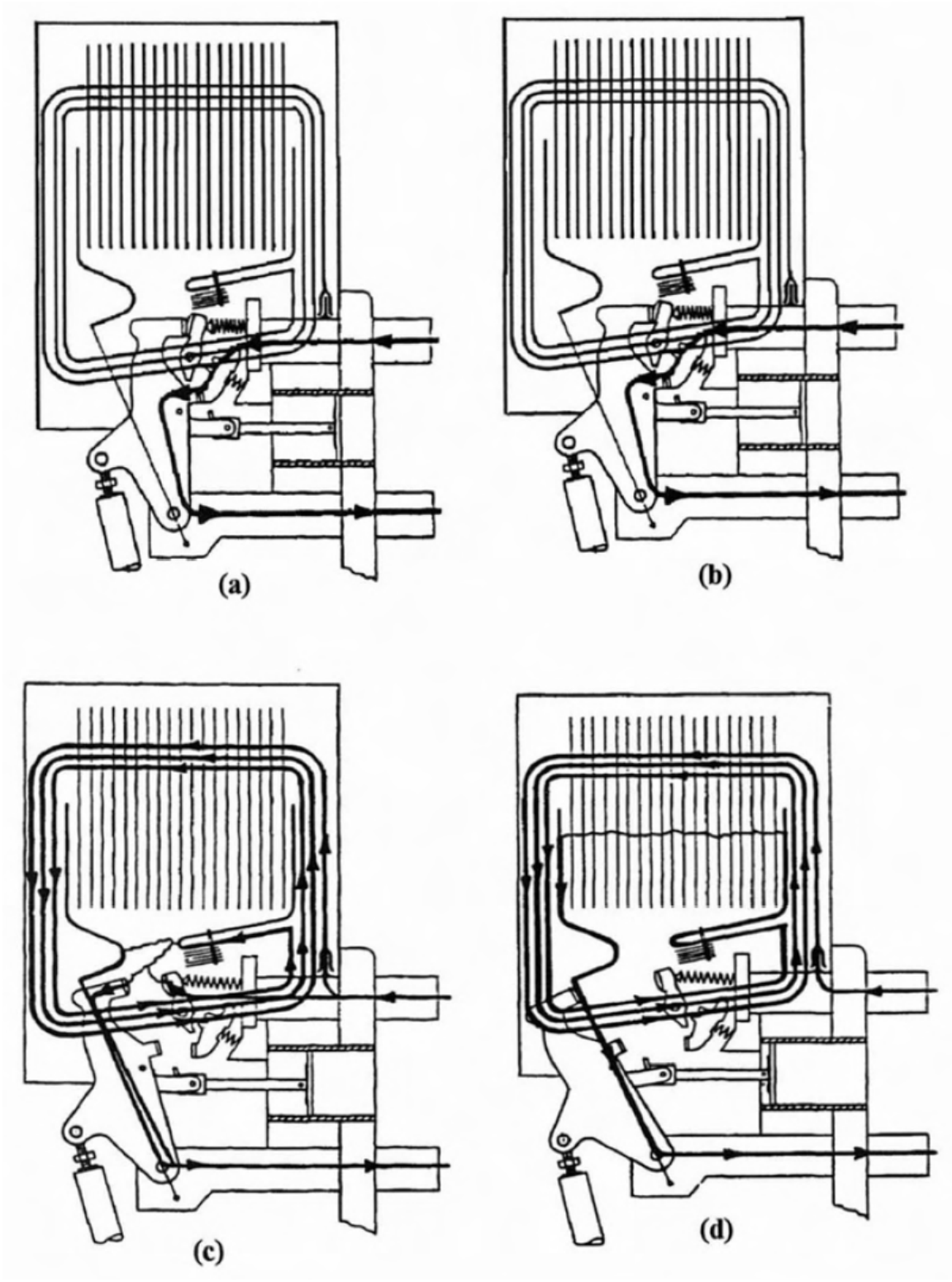

Figure 4: Graphic operation of a magnetic circuit breaker with a blow out coil a) Normal current carrying, b) Initial contact separation, c) Current transferred to arcing contacts and electro magnetic coil inserted into the system, d) Coil assist in the arc continuing into the runners [3]

2.2.1.2 Air Blast Circuit Breakers

An air blast circuit breaker, as the name suggests, extinguishes arcs through the opening of a blast valve at arc contact separation. The pressurized air flowing through the arc contacts results in high dielectric characteristics in the arc gap as well as fast cooling, thus in this type of breaker no arc lengthening is used [4]. This type of arc quenching technology can be utilized with various gaseous mediums, and also depict the most commonly used generator circuit breaker technology i.e. gas blast. Three arrangements that are regularly used can be seen in Figure 5.

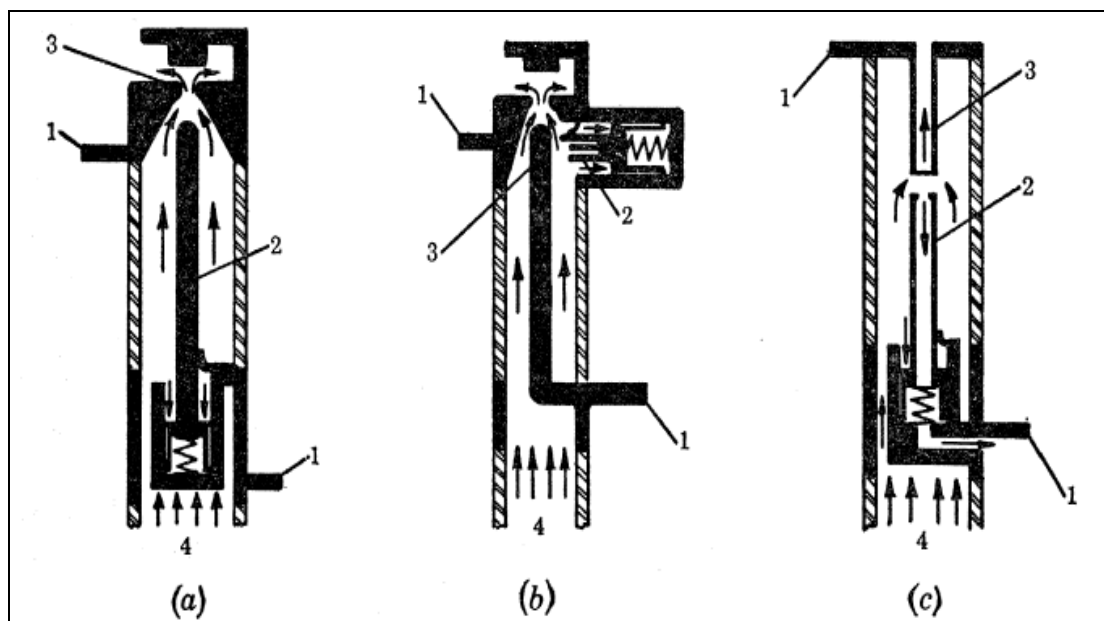

Figure 5: Basic operations of air blast circuit breaker operations [4]

The three arrangements are:

- a) Axial flow with axial moving contact
- b) Axial flow with side moving contact
- c) Radial flow with axial moving contact

And the numbered tags represent:

1. Terminal
2. Moving contact
3. Fixed contact
4. Blast Pipe

Along with the various configurations the blast valve can be used in either live or dead tank designs with multiple positions of mounting. According to Kelsey and Petty [4], the preferred air blast circuit breaker in high voltage applications is the pressurised head circuit breaker that can be seen in Figure 7. This technology can be generally described as gas blast circuit breakers, since various forms of gasses can be used for the interruption and cooling of the arc [3]. For this reason, the arc quenching process will be handled within the SF₆ chapter of this document.

Further flow configurations include the cross blast mechanism, which is the preferred mechanism for medium voltage applications and high current applications [3]. All the above-mentioned configurations need a correctly directed blast of gas to effectively cool the arc. This can be achieved by a D’Laval type of converging-diverging nozzle, with a choice of metallic, insulating or conduction nozzles [4]. Independent of the nozzle design the primary purpose of the gas blast is to force the arc to the arc catcher, or arcing contact. This can be clearly seen in Figure 6. With this configuration the arc length can be dramatically increased in a short time by the high-pressure gas flow [3].

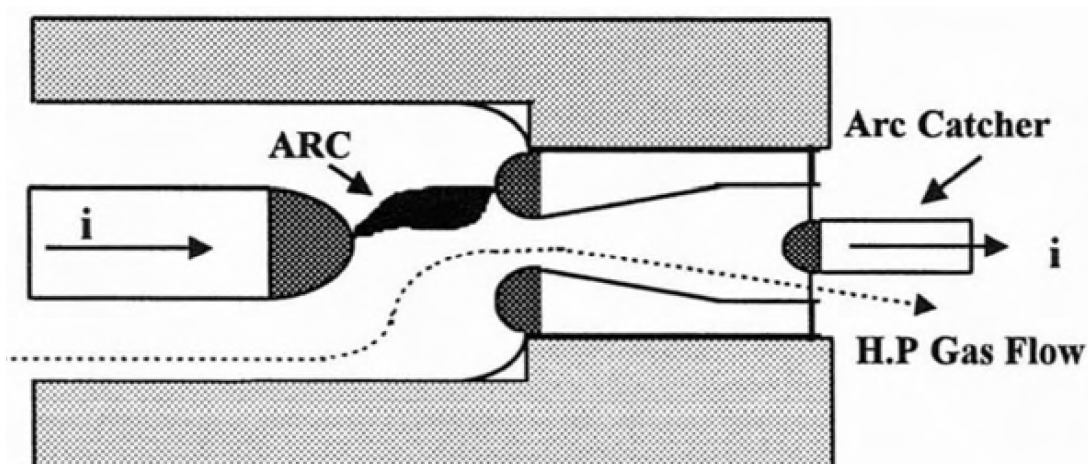

Figure 6: A graphical representation of a conducting single flow nozzle [3]

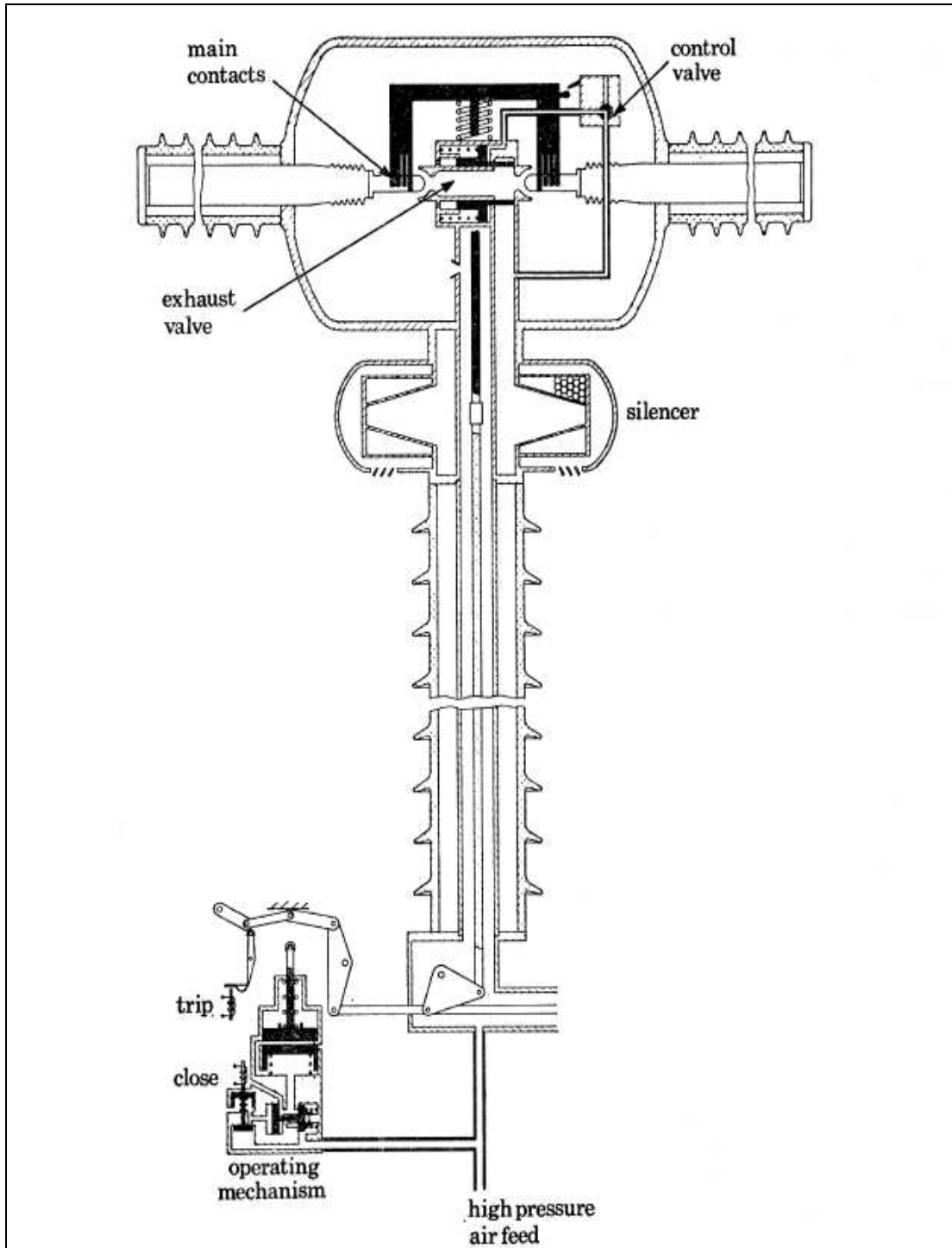

Figure 7: Pressurized-head air blast circuit breaker [3]

A comparison between conducting and insulating nozzles indicates limited differences in design. The differences were found to be the insulating material forming the nozzle and the gas flow characteristics. The gas and arc interaction is the same once the intended arc contacts are reached.

Gas blast circuit breakers can also be connected in series to increase interrupting voltage over the combination of the stages. This can only be achieved with the proper control of the voltage divider over the interrupters as well as the gas flow control to ensure stable conditions throughout the various interrupters [3]. The inherent capacitance difference between the interrupters can also be overcome by sufficient compensation.

Various improvements have been made to ensure that the gas blast breaker can be used within modern systems. One of these modifications includes pressurising the interrupting chamber at maximum pressure. This eliminates the need for an air-insulating valve, reducing the time for opening and re-closing as well as eliminating the noise associated with other gas blast designs.

2.2.1.3 Advantages and disadvantages

Air blast circuit breaker's performance is mostly influenced by the operating pressure, nozzle diameter and interrupting current. This will be further explored within the SF₆ blast breaker and is referred to in this section.

On the other hand, the air magnetic circuit breaker is more dependent on the voltage magnitude, and the interrupting capability increases with lowering system voltages [3]. Another benefit of voltage controlled air breakers is the modification of the normal wave of the fault to advance a current zero [3]. This is a result of the high arc resistance and can be a great advantage in the switching of high asymmetric fault current components. One such application is the protection of large generators, although the disadvantages of these breakers include the size and cost compared to similar modern breakers. Further disadvantages include a short interrupting contact life, a high energy operating mechanism and the risks associated with the exposure to hot gases following the interruption of short-circuit current

Thus, considering the decreased dielectric characteristics of air in comparison to other gases and the expensive nature of the outdated technology it might

be perceived that this technology is not used in the modern power systems. This is not true as the largest rated generator circuit breaker in the ABB range is a metal clad air blast breaker rated for 2 000 MVA generating units [8]. This breaker can be directly incorporated into the high current bus ducts and is designed with redundant cooling equipment to ensure reliability.

This type of breaker is used if there is a need for a large breaking capacity, but further considerations must be evaluated for the impact of the design for an air interrupter. More space is required for the expansion of the air pressure, the air compressor plant and some structural modifications are some requirements for the operation and maintenance of such a breaker. The structural modifications are required as a maintenance pit under the breaker is required. A typical specification of an air blast generator circuit breaker is shown in Table 1, with a graphical representation depicted in Figure 8.

Table 1: Example of technical specifications of an air blast generator circuit breaker [8]

Type designation	DR 36 v 1750 D	
Rated voltage	kV	36
Rated short-time power-frequency withstand voltage 50 Hz, 1 min. against earth	kV	75
Over open isolating distance	kV	100
Rated lightning impulse withstand voltage 1.2/50 μ s against earth	kV	170
Over open isolating distance	kV	195
Rated frequency	Hz	50/60
Rated current		
– self-cooling	A	up to 11 000
– forced cooling	A	up to 50 000
Breaking current	kA	250
Making current (peak value)	kA	400-750

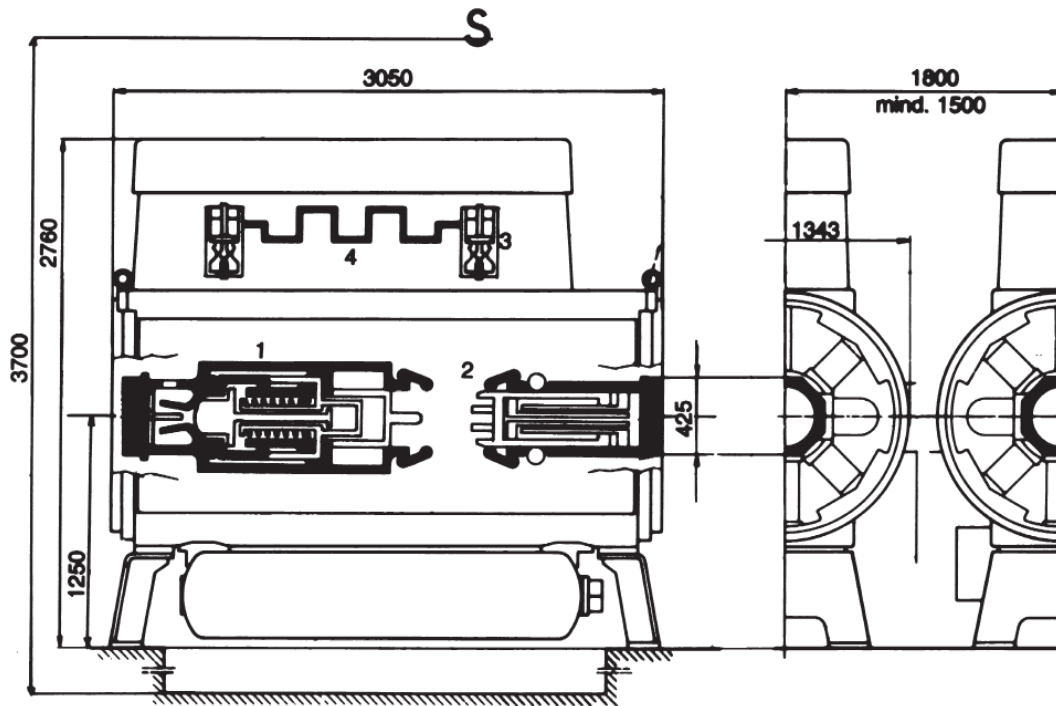

Figure 8: Schematic diagram of an air generator circuit breaker [8]

According to the ABB switchgear manual [8] the components labelled in Figure 8 are:

1. Circuit Breaker
2. Linear-travel disconnect
3. Auxiliary chamber
4. Low-resistance resistivity

2.2.2 Oil Circuit Breakers

As one of the oldest types of breakers, the oil circuit breaker, have been widely used throughout the world. Oil circuit breakers in various forms are still in use today. This breaker uses the high dielectric abilities of insulating liquid for interruption and in some cases for insulation. This must be evaluated with the risk involved with oil as a fire hazard and the associated maintenance of outdated equipment in mind.

2.2.2.1 Bulk Oil

An early design of an oil circuit breaker can be seen in Figure 9, and was built in 1901. This device operated at 40 kV with a short circuit fault rating of 200 A to 300 A and remained in service for a year [3].

This type of circuit breaker uses oil as interrupting and insulation medium. This type of circuit breaker is usually operated in the voltage range of 1 kV to 330 kV. The Bulk Oil Circuit Breaker (BOCB) technology developed from just submerging the contacts in oil to the development of a side vented 'explosion pot'. Bulk oil and air blast circuit breakers were quite common until the mid 1970s for outdoor applications at voltages ranging from 15 kV to 345 kV [3].

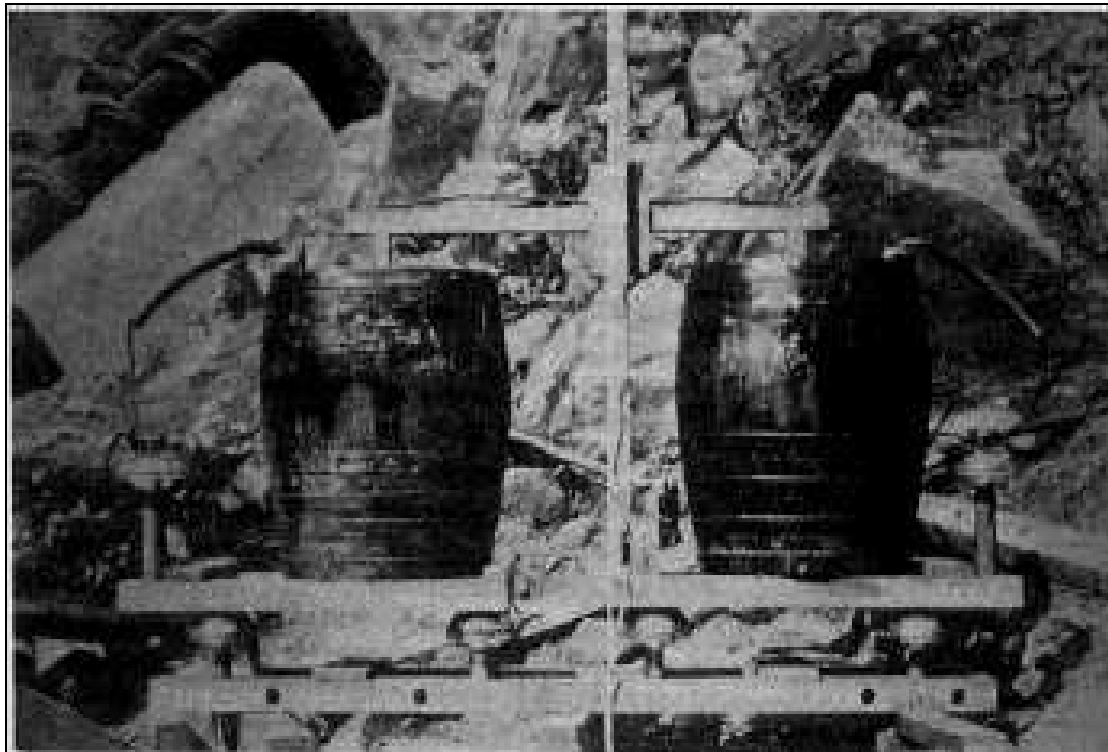

Figure 9: Original Oil Circuit Breaker Design [3]

Initially this method of current interruption relied on submerging the current carrying contacts in an oil bath. The cooling and extinguishing of the arc is achieved through the properties of hydrogen, created by the arc, with the aid of the distance between the contacts. This combination resulted in the dielectric strength required to inhibit a re-strike. Another attractive property of

using oil as an interrupting medium is the fact that with increased fault currents the pressure within the arc chamber increases, resulting in increased vaporization of the oil around the arc. The de-ionisation properties of the hydrogen bubble also increases and assists in increased dielectric strength [2]. This effect relies on the mechanical strength of the device as well as the proportioning space above the oil level to ensure that the rise in pressure does not damage the equipment.

Further pressures within the expanding electrical distribution and transmission system resulted in the development of the side vented arc control device. The principle of operation is that pressure developed by the vaporisation and dissociation of oil is retained in the pot, by separating the moving part by insulating radial plates, with minimum radial clearance to ensure pressure retention. No pressure is released until the moving part uncovers one of the side vents. The pressurized hydrogen gas developed in the arc chamber is released across the arc path causing an intense cooling action. At current zero the post arc resistance increases rapidly after the clearance occurred [2]. Figure 10 depicts the process described above.

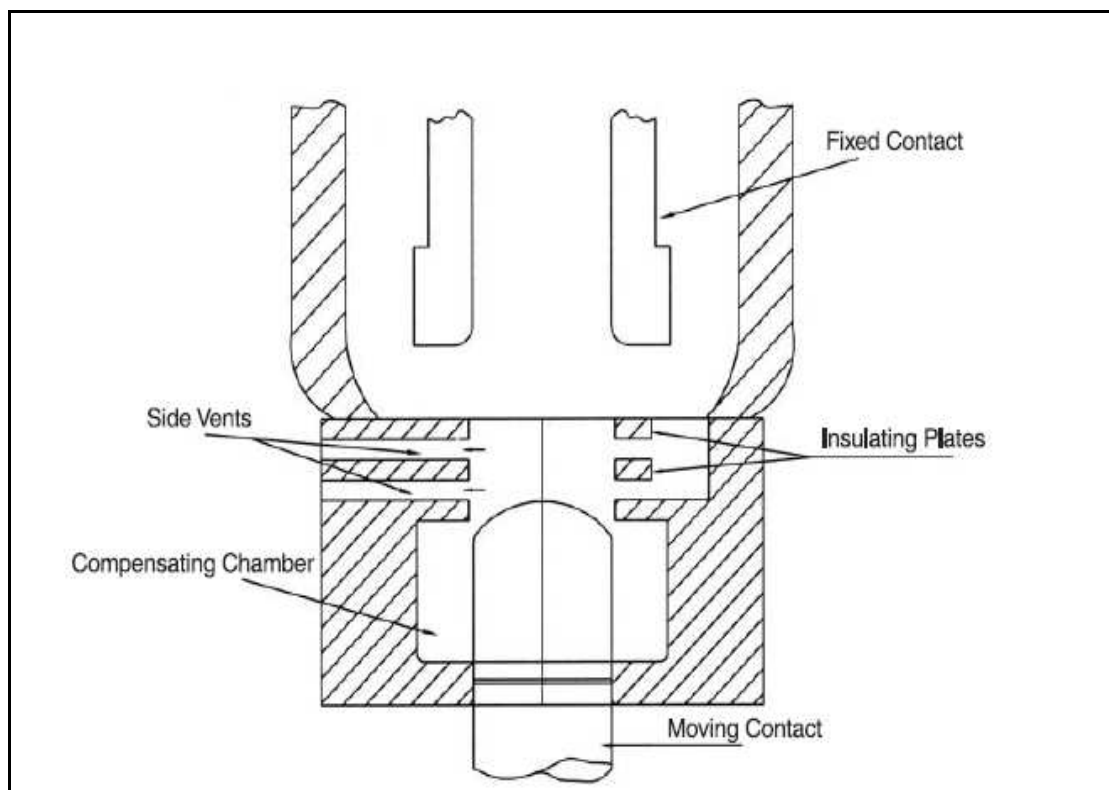

Figure 10: BOCB with side vented arc control device [2]

With lower fault current, problems occur due to the cooling effect being less effective. This problem was solved by the use of a compensating chamber, supplying the arc with sufficient oil to vaporize to ensure current interruption.

The bulk oil circuit breaker is limited to the 330 kV range, due to restrictions in the design. These types of breakers require a large amount of oil (approximately 50 kℓ for a 330 kV breaker), and with the increase in oil volume the associated environmental and fire risk also increases. The need for high-speed contact separation and energy intensive mechanisms resulted in the development of minimum oil and air blast breakers.

2.2.2.2 Advantages and disadvantages

Although this type of breaker is the preferred technology with the older generations, mainly because this technology has a proven track record, this breaking medium relies on frequent maintenance and inspections to ensure reliability. The inherent fire risk associated with oil used as well as the environmental impact of spills, assisted in the restricted application of this type of breakers. With the development of superior technologies such as air blast circuit breakers, this technology was only used in distribution class applications and for indoor circuit breakers.

2.2.2.3 Minimum Oil Circuit Breaker

With the expansion of the transmission and distribution networks in the mid-nineteenth century, the minimum oil circuit breakers were regularly used for a replacement for air and bulk oil breakers. This was true for most installations outside Europe [3].

These types of circuit breakers only use oil as the interrupting medium and not as insulating material in all chambers. This type of circuit breakers is normally used in 1 kV to 76.5 kV applications [2]. A typical 36 kV MOCB is shown in Figure 11.

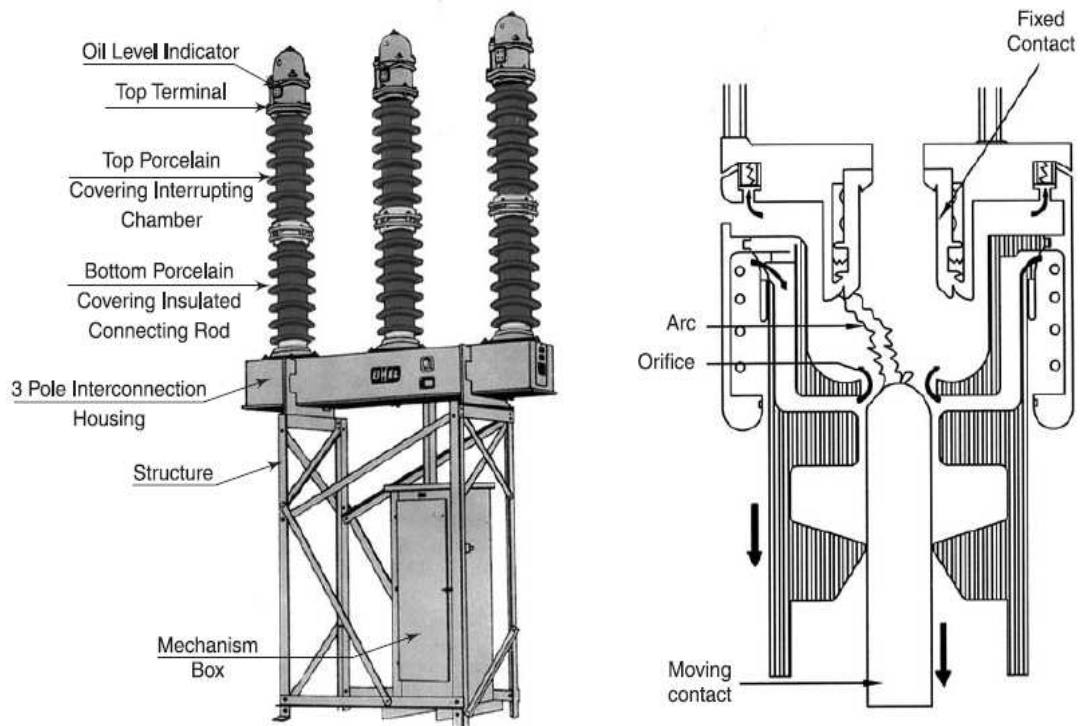

Figure 11: Representation of 36 kV MOCB [2]

These types of breakers are widely used in transmission and distribution networks, but have a known sensitivity to transient recovery voltages (TRV) and are prone to re-strikes during the switching of capacitor banks.

One of the latest developments in this breaking medium was the development of an interruption capability of 50 kA. These fault levels can be interrupted in 145 kV and 245 kV systems, with a prolonged life achieved by the pressurizing and sealing of the unit with dry nitrogen. This eliminates the effects of moisture on the device in the field and in outdoor applications.

The operation of a minimum oil circuit breaker is similar to that of the bulk oil circuit breaker, as the arc is contained within the arc chamber. This results in a pressurized bubble of vaporized hydrogen around the arc. This pressure is released by an orifice when contact separation distance is reached. This results in the rapid cooling of the area between arcing contacts and fast de-ionisation at current zero. This in turn gives rise to transient recovery voltages over the contacts aiming to reinstate the current flow. This can result in a re-

strike and an unsuccessful interruption. This effect can further be complicated with the switching of capacitor loads and out-of-phase currents, but can be addressed by pressurizing the device with dry nitrogen.

2.2.2.4 Advantages and disadvantages

This type of breaker was more effective than its direct competitor, the air blast breaker, in low ambient temperatures. The cross blast design of minimum oil breakers has some flaws, such as sensitivity to peak voltages and the effects of pre-arcing. This technology, as was the case with bulk oil circuit breakers, has been totally replaced in the medium voltage range by vacuum and SF₆ circuit breakers and with SF₆ in the high voltage range.

As was the case with the bulk oil circuit breaker the restricted capability and the smaller effectiveness of the interrupting medium, resulted in the preferred mediums for modern generator circuit breakers to be SF₆, vacuum and limited applications of air blast circuit breakers. Although these breakers are not preferred as generator circuit breakers, they are still widely found in field on the high voltage side of the generator transformer. This interruption medium has all the qualities required for generator circuit breaker applications, but the associated environmental and fire risks are the major cause for the restricted use.

2.2.3 Vacuum

An interest in vacuum breaking technologies has been regularly investigated through the developmental stages of the investigation of the modern circuit breaker. The vacuum technology is the improvement of the weak dielectric properties of air, without the environmental risk of SF₆ and the fire risk of oil.

Using “high” vacuum as an interrupting medium has been seen as an alternative from the nineteenth century onwards, although only in theory [6]. The interrupting ability of this medium was demonstrated first by the California Institute of Technology in 1923 to 1926, through the development of a circuit breaker able to interrupt 900 A at 400 kV [6]. Although limited progress was

made in the development of vacuum circuit breakers until the 1950s, breakers capable of interrupting 4 kA to 5 kA on 15 kV levels were available.

Research throughout the 1950s in the U.S.A. and the U.K. produced the first power interrupter capable of interrupting 12.5 kA at 15.5 kV [6]. The research concentrated on the study of the physics of vacuum arcs, principles of vacuum arc extinguishing, control of current chopping and arcing contact design. This resulted in the building of a power circuit breaker.

In Figure 12 four interrupters were used to establish the 15.3 kA, 132 kV circuit breaker commissioned in the U.K. in 1967. Each one of these interrupters is rated at 15.3 kA and 16 kV respectively. The circuit breaker has a continuous current rating of 1200 A. In Figure 12 the interrupters are contained in each half of the head of the T structure [6]. With these interrupters the line faults and transformer faults can be interrupted without the use of switching resistors. The interrupters are mechanically operated by spring mechanisms for reliable operation.

Further evolutions of this type of breaker resulted in interrupters able to break 40 kA in single interrupters [6]. Various problems were also eliminated by the development of contact materials for the arcing contacts [6].

As the name implies this type of circuit breakers interrupts the current within a vacuum, at approximately 10^{-6} mbar for new interrupters [5]. The circuit breakers has been successfully developed and used in the medium voltage range. Higher voltage installations have been developed, but are not commercially available yet.

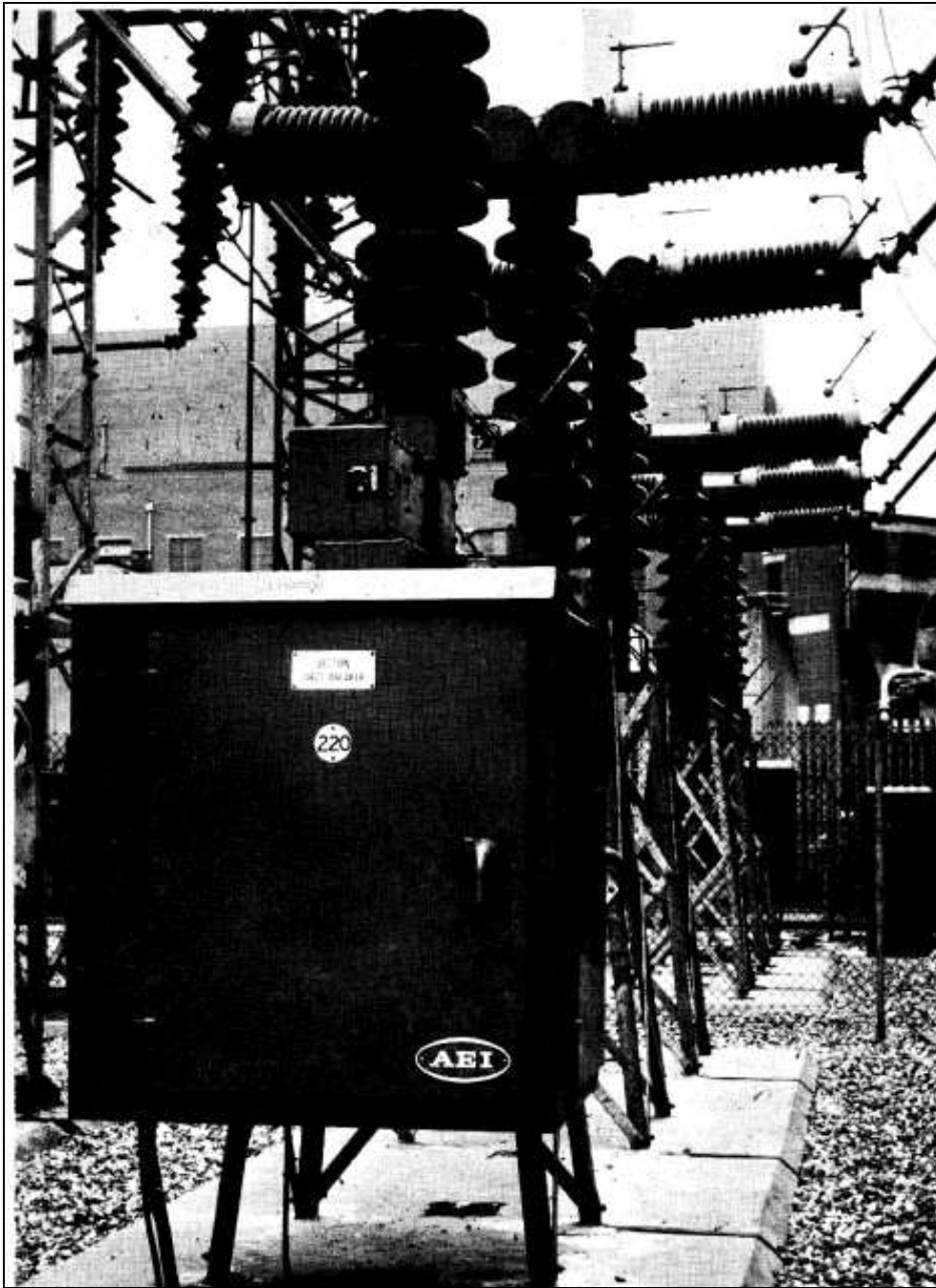

Figure 12: Vacuum Circuit breaker commissioned in the U.K. in 1967 [6].

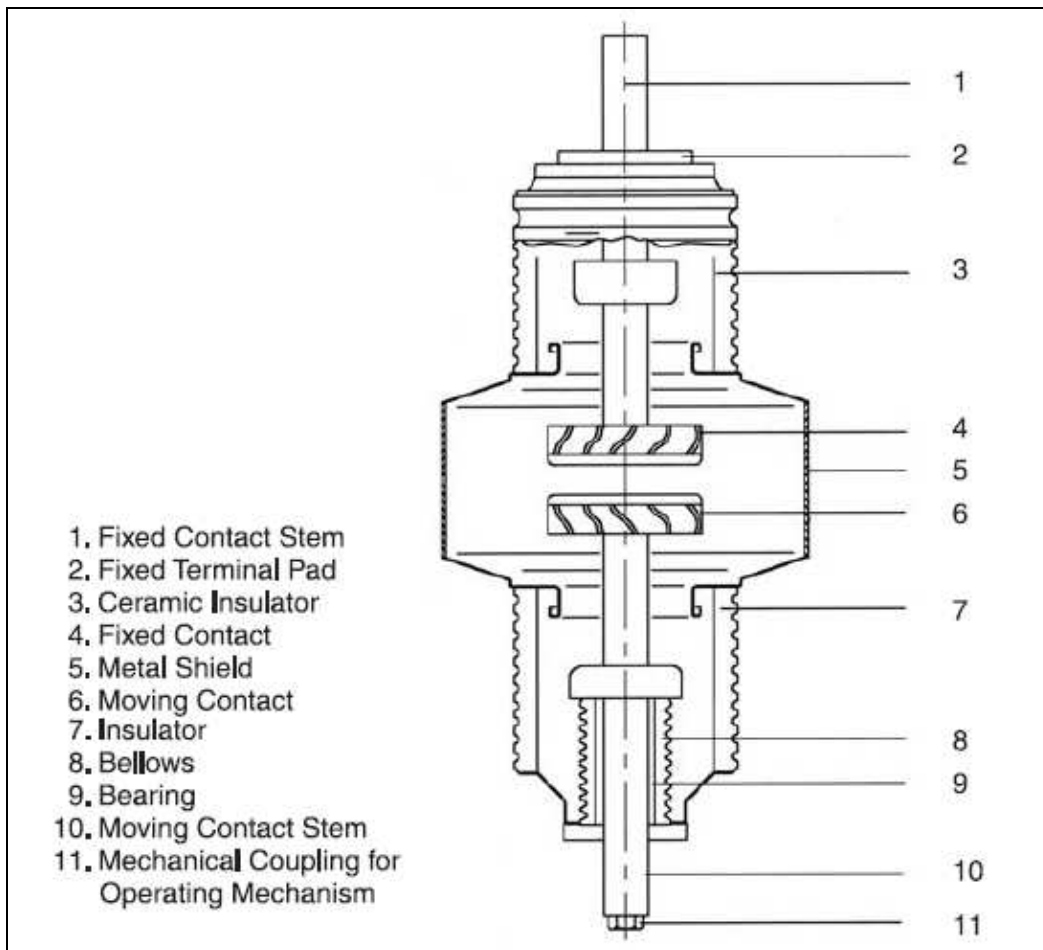

Figure 13: Schematic diagram of the typical components of a vacuum circuit breaker [2].

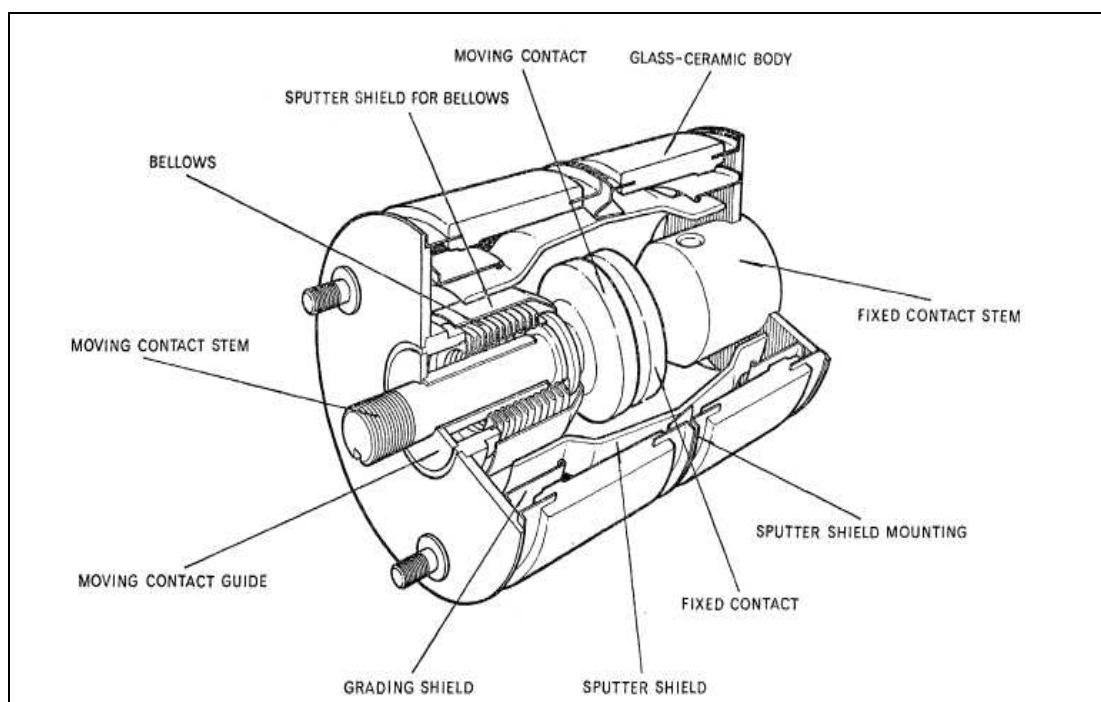

Figure 14: Basic Components of a vacuum circuit breaker [6]

In Figure 13 the basic components of the vacuum circuit breaker can be seen. Number (5) in the sketch, named “Metal shield”, is the arcing chamber housing the arcing contacts.

One of the key elements with this type of circuit breaker is the specific metals used in the arcing contacts. Common metals used in this application are CuBi, CuCr, and CuAg [2]. CuCr has proven itself as the ideal solution in the 8 kA to 63 kA range, due to the high boiling point and thermal conductivity [6]. In this alloy, chromium is distributed through copper in the form of fine grains. This material combines good arc extinguishing characteristics with a reduced tendency of contact welding and low chopping current when switching inductive current. The use of this special material is that the current chopping is limited to between 4 A and 5 A [7]. This type of vacuum interrupter technology has evolved from the 1960s and is still evolving today. For example, the diameter of vacuum interrupter contacts has reduced from 275 mm to just 50 mm [2]. The experts think that vacuum medium voltage type breakers will be the only choice in the twenty first century [ref].

According to “Bharat Heavy Electrical” the SF₆ type breakers are lagging behind in the following areas when compared to vacuum breakers.

- *Long Life*: The vacuum circuit breakers can now be produced at low cost and with such long lives, even exceeding the required prolonged circuit breaker life [2]. To quantify this, between 10 000 and 50 000 Closed-to-Open operations are claimed by original equipment suppliers.
- *Environmentally safe*: All the materials used in the construction of these circuit breakers are non-hazardous. Whereas SF₆ type breakers have to have hazardous waste handling plans as well as regular maintenance. Care should also be taken when the SF₆ breakers are replaced at the end of their lives [2].

- *Superior Performance:* Through comprehensive research and development the vacuum circuit breakers are installed with relative ease and can be interchanged [2].

It is clear that these types of circuit breakers will be very important in the future of circuit breaker technology.

With all the developments for economically viable vacuum circuit breakers, the application of this technology is the preferred technology below 24 kV. Although most suppliers are able to provide vacuum breakers from 7.2 kV up to 36 kV, the preferred breaker for higher voltage applications still remains SF₆ [9].

Vacuum Characteristics

A vacuum can be defined when a gas molecule behaves as if it were practically alone. As stated earlier a “high” vacuum is in fact a low-pressure gas. This can be seen by evaluating a 1 mm³ volume of vacuum with a pressure of typically 10⁻⁶ mbar. Within this volume there still exist 27x10⁶ gas molecules, but their interactions are negligible as their average free path between collisions is 100 m [5].

At pressures above atmospheric pressure, the dielectric behaviour of air generally follows the Paschen Curve [5]. The product of the pressure and the distance between electrodes determines the dielectric breakdown of air, and results in the Townsend avalanche method of breakdown. But this is not the case with lower pressures as the electrons decay on the path between collisions as the distance is so vast. This effect is utilized in circuit breakers using vacuum as interrupting medium, and also dictates the degree of vacuum necessary. Due to the lack of ionisation mechanisms in this type of breaker the effects of electron emission becomes more critical. This act of extracting electrons from the electrodes occurs with sufficient rise in temperature or a strong electric field applied to the metal surface [5]. The latter case is more applicable to vacuum interrupters and can be modelled by the simplified Fowler-Nordheim equation

$$j_e = \frac{AE^2}{\phi} \exp\left(-\frac{B\phi^{1.5}}{E}\right) \quad (2.1)$$

Where: j_e = Electronic current density (Am^{-2})

$$A = 1.54 \times 10^{-6} \text{ AJV}^{-2}$$

E = Electric field in V/m

Φ = work function in eV

$$B = 6.83 \times 10^9 \text{ VJ}^{-1.5}/\text{m}$$

Between 10^9 V/m and 10^{10} V/m is needed to cause field emission from the surface of the electrodes or contacts. This, although not typical for vacuum breakers field emissions, have been observed by researchers [5]. Scientists speculate that this is due to impurities or insulating materials in the contact surface increasing the electric field [5]. This effect limits the dielectric withstand voltage capability of a new interrupter, raising the need to condition these emission sites on the contacts. This can be achieved by multiple breakdowns, destroying these sites or at least limiting their enhancement factor [5]. Multiple breakdowns can be obtained by applying a high voltage for a few minutes, and through the breakdown that occurs because the dielectrics withstand to increase to the expected values. The progressive increase of dielectric breakdown can be seen in Figure 15, with multiple breakdowns applied. Figure 15 is a scatter plot of experimental results and the fitted line plot representing the general response due to voltage conditioning.

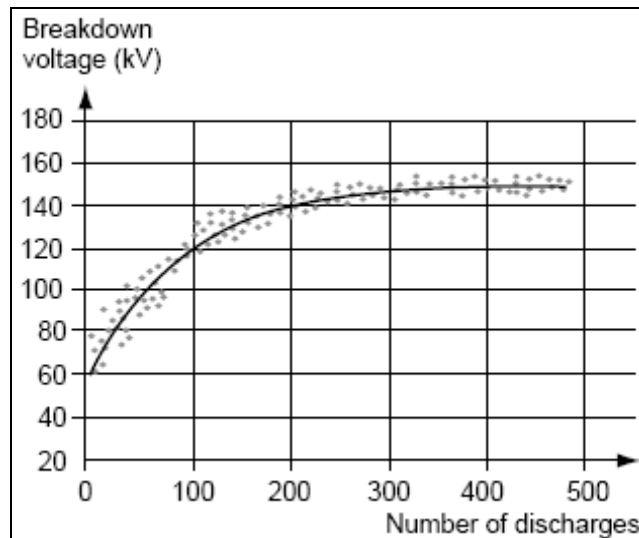

Figure 15: Representation of voltage conditioning in vacuum interrupters [5].

This electron emission does not generally degenerate the dielectric breakdown to such an extent to cause breakdown without the increase in applied voltage, but the breakdown in vacuum circuit breakers usually results from the formation of localized plasma. This ionised gas, which should be sufficiently dense, causes an electron avalanche phenomenon and results in dielectric breakdown of gas [5]. The formation of this plasma can be explained in the following steps [5]:

- It can be produced on the cathode region by electron emission;
- Intense overheating causes the destruction of the emissive site resulting in metal vapour;
- The highly energetic electrons bombarding the anode region, causes the de-sorption of gasses on the surface, and
- The released gasses results in the partial vaporization of the anode metal, and this gas ionises through beam electrons to cause breakdown.

Vacuum Arc

According to Picot [5] arcs in a vacuum can be explained by two modes, i.e. diffused and constricted. Diffuse mode arcing is limited to arcs that form in a vacuum, and naturally adopts the breaking current range [5]. This mode of

arc causes neutral plasma around the cathode, consisting of electrons and charged ions. Within the plasma the electric field and extreme temperatures causes the combination of thermo and field electronic emissions. Due to the high current densities produced, a single spot in the arcing contacts is formed of 5 μm to 10 μm that can emit up to 100 A [5]. Above 100 A the spot divides and coexist within the cathode plasma. Another characteristic of the diffuse mode of arcing is that the arc occupies the entire area of the cathode, consisting of various spots within the plasma with opposing forces [5]. The plasma immersed cathode functions as a passive electrode collecting charges. This results in a 20 V voltage drop in the region of the cathode, and results in lower erosion as the level of ion emission is lower.

In the constricted mode of arcing the diffuse method of arcing forms on the anode side as the current increases, except that the current is constricted to a limiter area of the anode. This allows for the anode to attract electrons resulting in a positive anode voltage drop and the diminishing of the neutrality of the cathode [5]. The increased energy supplied by the electrons in a restricted area heats and emits neutral particles. The neutral particles are energised by the incident electrons, and form plasma at the anode region. Although less energetic than the plasma of the cathode, this plasma form a luminous anode spot, much larger than the cathode spots. This spot, made up of molten metal, spills vapour into the inter-electrode gap, and became energised by the cathode flow [5]. This results in a similar cathode spot forming, and the mechanism now relies on the ionisation of the metallic vapours in the electron gap.

2.2.3.1 Advantages and disadvantages

To ease the evaluation of this breaking medium it will be explained by the breaking capacity, dielectric withstand and current flow the advantages and disadvantages of the interruption medium. This will be used as a tool to evaluate the best properties as well as the weak points of this technology.

Table 2: Strengths and weaknesses of vacuum as an arcing medium [5].

Field	Characteristics	Strong points	Weak points
Breaking capacity	Very rapid dielectric recovery	Breaking of fault currents with severe di/dt and TRV.	Breaking of HF currents following restrikes: overvoltages are generated, protection devices necessary in certain networks.
	Low arc voltage (energy).	High electrical endurance.	No current limiting effect in LV.
	Ability to break even without contact movement.	Current interruption in case of striking between open contacts (partly compensates for the lack of reliability of the dielectric withstand).	
Dielectric withstand	Influenced by the surface condition of electrodes and the presence of particles.		Intrinsic dielectric withstand limited in HV and may change over time.
	Influenced by the arc phase that immediately preceded.		Random post-break dielectric withstand: risk of re-striking after capacitive breaking if the interrupter is not adapted.
Current flow	Non-compensated contacts of the butt type.		High contact pressure needed to prevent "popping" by electromagnetic force.
	Contacts in vacuum.	Constant contact resistance (no oxidation and no deterioration upon breaking).	Tends to weld upon closing.
	Same contacts for continuous current flow and breaking.		High contact resistance: significant thermal dissipation for high ratings.
Breaking environment	Vacuum < 10 ⁻³ mbar.	No decomposition products and no effects on the environment.	Permanent monitoring of the vacuum level is impossible: periodic dielectric checks make shutdown necessary.

With a chrome copper contact vacuum circuit breaker, the operating requirements are low due the mechanism moving only small distances with low mass [7]. The fact is that the vacuum arcs dissipate limited energy, with almost no contact erosion, and the "sealed for life" constructions requiring less monitoring [7]. For this reasons the medium is depicted to be an almost perfect interrupting medium [7]. Furthermore, the rated life of a vacuum interrupter is longer than that of a SF₆ circuit breaker. This is due to the simplistic design and less moving parts [7]. Field testing does not suggest that any of the two are more reliable, but some tests suggest that vacuum circuit breakers are able to perform more short-circuits and rated current interruptions than the alternatives.

Vacuum breakers can be used without design modifications as generator circuit breakers [8]. This is true for generators rated up to 100 MW and 20 kV, and supplies the electricity provider with a compact solution to limit damage to the generator due to fault conditions. One such vacuum generator circuit breaker is the ABB type VD4 G breaker, incorporating earthing capabilities, voltage and current transformers. A typical example of ratings for such a circuit breaker is [8]:

Rated Voltage:	17.5 kV
Rated Short Time power frequency withstand voltage	50 kV
Lighting impulse withstand voltage	110 kV
Rated Current at 40 °C ambient	5000 A (with forced cooling)
Rated Breaking Current:	40 kA (system source, symmetrical)
	25 kA (generator source)

2.2.4 SF₆

Two newer technologies, one using vacuum and the other sulphur hexafluoride (SF₆) gas as the interrupting medium, made their appearance at about the same time in the late 1950s, and are now used in what is considered to be the new generation of circuit breakers [3].

The use of this type of breaker gained popularity when metal clad SF₆ circuit breakers were developed [2]. This was due to the outdoor type breakers being of a similar design to ABCBs (Air Blast Circuit Breakers), only exchanging the extinguishing gas. The pressure rise is obtained by gas compression in a compression chamber. This gas is released into the arcing region and captured in a low-pressure receiver, where the gas is pressurized and pumped to the high-pressure receiver.

In 1957 a puffer type technique was introduced for SF₆ high voltage breakers. This provided the pressure needed to quench the arc by using the relative

movement of a piston and a cylinder linked to the moving parts, and the application through an insulated nozzle.

The second-generation SF₆ circuit breakers were named single pressure SF₆ breakers [2]. This technology addressed the problems associated with pressurised SF₆ and further developed by the incorporation of thermal assistance techniques to assist in the energy requirements for opening.

Further improvement in the thermal technique was obtained by using a valve between the expansion and the compression chambers. The third generation SF₆ breakers using the thermal or self-blast principle are used up to 245 kV. Future developments can see this principle be used up to 420 kV [2].

In this type of circuit breaker the contacts open and close in Sulphur Hexafluoride (SF₆). SF₆ circuit breakers are available in all medium and high voltage breaker ranges up to 800 kV. It must be noted that live tank designs with a 800 kV rating consists of four interrupters in series, and dead tank designs can consist only of two interrupters in series [2]. These versatile and commonly used circuit breakers are not without any downsides, the SF₆ gas used has been identified as a greenhouse gas and regulations require that the gas does not get released into the atmosphere. SF₆ gas is 22.5 times more potent than CO₂ in its global warming potential per mass when released into the atmosphere [12]. SF₆ gas is also 5 times denser than air and one of the heaviest gasses at 146.05 g per mol [12]. This results in the inert gas remaining on the surface of the planet resulting in the greenhouse effect by the great thermal insulating characteristics of SF₆ gas. For to this reason, monitoring of the amount of SF₆ gas released into the air are strictly regulated by the IEC 62271-1 standard, including the regulations for the handling and destruction of the gas. Through the development of SF₆ breakers the mass of high voltage circuit breakers has dramatically decreased with increased reliability. The newer generation breakers are rated for fault clearance in two cycles, limiting the damage to a power system due to fault currents.

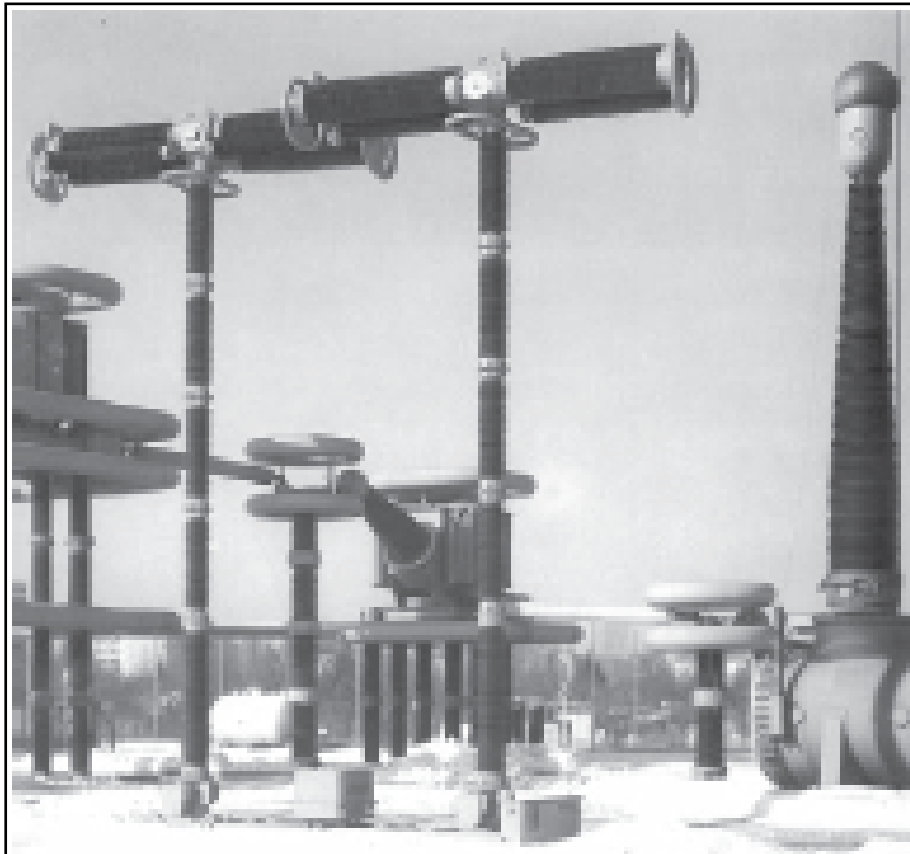

Figure 16: Photograph of a SF₆ circuit breaker [2]

In Figure 16, a SF₆ circuit breaker can be seen as the T-shaped figure. The specific breaker, is a single pressure (no pressure chamber) live tank breaker with two interrupters and is an excellent example of an outdoor 400 kV breaker.

Recent developments in the SF₆ circuit breakers include the upsizing of the self-breaking capability to 200 kA [9]. This eliminates the need for generator breakers of larger capacities needing to rely on air blast breakers.

Figure 17 demonstrates the quenching of the arc, by the separation of the contacts, a flow of cool gas is forced into the arc region thus cooling and quenching the arc. The picture also demonstrates how the internal elements are arranged in the breaking as well as the conducting stage. This phenomenon will be discussed in more detail later in this chapter.

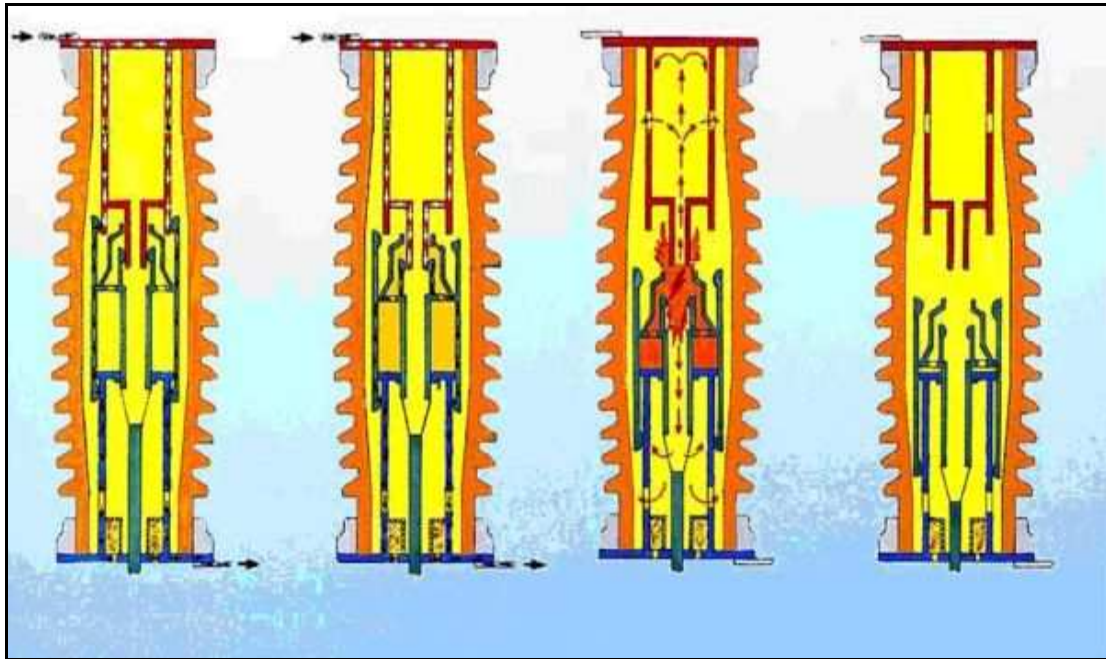

Figure 17: Schematic representation of the arc quenching mechanism of a SF6 circuit breaker: a) normal current carrying operation, b) current breaking is initialised and only arc contacts used to carry current, c) arcing between moving arc contacts and fixed contact, forced gas movement by the double piston self pressurized principle, d) interrupted current complete or open position [2].

The success of the SF₆ circuit breaker comes from:

- Simplicity of the interruption chamber;
- The autonomy provided by the puffer technique;
- High performance with less interrupting chambers;
- Short break time (2 – 2.5 cycles);
- High electrical endurance, allowing 25 years of operation without reconditioning;
- Possible compact solutions;
- Integrated circuitry to reduce switching overvoltages;
- Reliability and availability, and
- Low noise levels.

Although these characteristics are wanted in a circuit breaker, some elements like the high amount of energy needed to switch such a breaker, led to the

new technology of thermal blast chambers. Another disadvantage of the dual pressure type breakers is that the high pressure SF₆ gas liquefies at high pressure and low temperatures [2]. The objective was to reduce operating energy, but also to increase reliability by reducing dynamic forces on the pole [1]. The reduction was mainly achieved by the use of the arc energy to compress the gas and quench the arc.

In Figure 17 the non-moving contact, arc contacts and the moving contact can be seen. The area between the moving contact and the stationary piston is the pressure building area for arc extinction. This pressure is produced by the reduction in the volume of this space forcing the gas to the needed area. The rapid exit of the gas to the arcing area, results in a vacuum like action and the ease of movement is increased for the moving contact, also known as thermal assisting single pressure puffer type SF₆ circuit breakers [2]

The single-pressure sulphur hexafluoride breakers were developed to eliminate restrictions in the design of the dual pressure type breakers. The compression required to create the pressure needed to extinguish the arc is created by the movement of the compression chamber against a fixed position piston.

Although the arc interruption through the single and dual pressure technique is similar in operation, the composition of the moving contact is quite different. Figure 17 represents a single-flow series piston arrangement and in Figure 18 the single and double self-blast thermal assist SF₆ configurations can be seen.

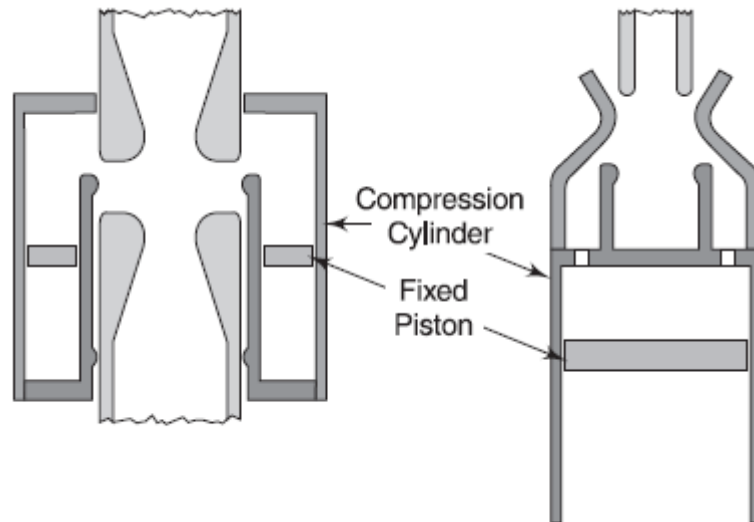

Figure 18: Representation of the single and double puffer interrupters [2]

2.2.4.1 Advantages and disadvantages

The application of SF₆ circuit breakers has become more advantageous as the self-pressurized circuit breaker was developed to need less operating energy. This, as the last cost limiting factor of SF₆ circuit breakers, allowed the technology to be implemented in high and ultra high voltage applications [7]. The inherent ability of SF₆ to dissipate limited energy through the arcing process aids in the effectiveness of this type of breaker, as contact erosion is restricted.

Further advantageous attributes of SF₆ are the high dielectric strength and the ability to recombine as SF₆ after interruptions. There is no loss or consumption, allowing for “sealed for life” breakers that need no supervisory pressure monitoring [7]. This medium with electro-negative capability allows for fast de-ionisation and the self-pressurized principle allows for limited exposure to current chopping induced overvoltages.

With units capable of interrupting 200 kA, the use of SF₆ as interruption medium is the preferred method used in power station generator circuit breakers. The same attributes that makes this breaker a major contender in the medium to high voltage range, also promotes it to be applied to high current applications without major modifications.

Fault currents up to 200 kA, can cause the generator's solid steel shaft to bend and break under the induced magnetic forces [9].

Furthermore, the immense stresses modern circuit breakers are exposed to includes synchronization with the main system, interrupting full-load current of the generator, switching in out-of-phase and interruption of system, and generator fed short-circuit currents [9]. Requirements in reliability resulted in the incorporation of multiple components within the secure housing of the generator circuit breakers. A schematic diagram of such a design can be seen in Figure 19.

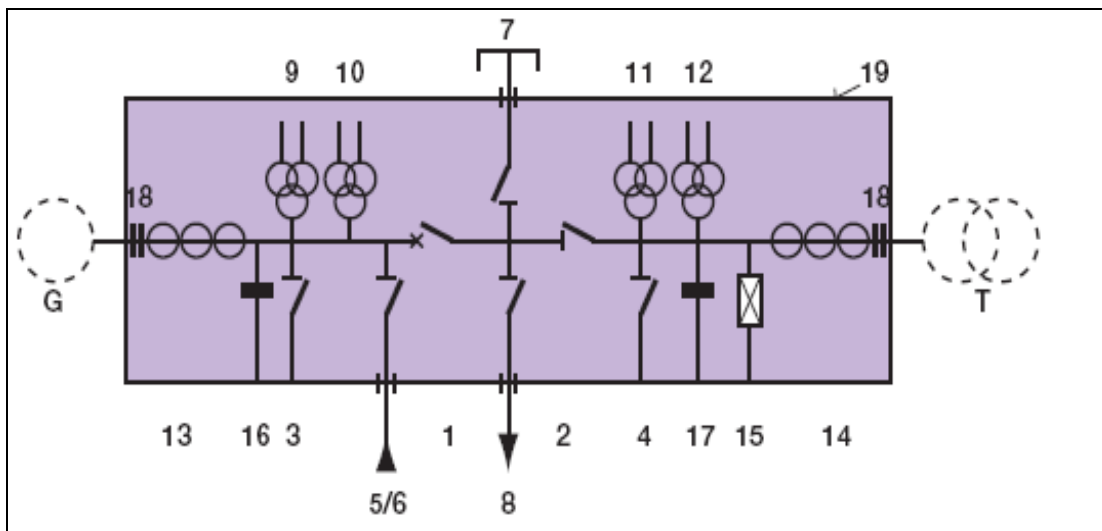

Figure 19: Schematic representation of an integrated generator protection system [9]

Within Figure 19 the numbered components are [9]:

1. Circuit Breaker
2. Disconnector
3. Earthing switch (up to 4)
5. Starting Switch (up to 6)
6. Short-circuiting switch/ breaking switch
7. Starting switch ("Back-to-back")
8. Voltage Transformers (up to 12)
13. Current Transformers (up to 14)

- 15. Surge Arrester
- 16. Surge Capacitors (up to 17)
- 18. Terminals
- 19. Enclosure

This fully functional circuit breaker allows the auxiliary systems to be supplied directly from the HV system and aids in the control of start-up and shutdown phases. This and other innovative ideas were used to develop and use this technology in modern generating stations. With the development of economically feasible SF₆ operating mechanisms, this technology is fast growing into the most reliable and preferred generator circuit breaker. Later sections will discuss the detail of generator circuit breakers.

2.3 CIRCUIT BREAKER OPERATING MECHANISMS

Opening and closing velocities as well as the stroke of the circuit breaker are of the utmost importance. This is complicated even further by the fact that circuit breakers are expected to stay dormant (in the closed position) for long periods of time, but react with perfect precision when operation is needed. Some of the most important characteristics of a circuit breaker includes the closing and opening velocities, as well as the contact travel distance.

The opening and closing velocities ensure the longevity of the contacts. The design is optimised too avoid contact erosion and contact weld. On the other hand the stroke is designed to withstand the dielectric stresses needed to break the rated current of the breaker. The IEC standard for the operating mechanisms is summarized in the IEC62271-100 [3]. The standard specifies two classes of mechanisms, i.e. M1 and M2 [3]. The ratings state that type M1 mechanisms have to operate 2000 operations, and type M2 mechanisms (special service requirement) of 10 000 operations. The number of operations that is specified can be seen in Table 3.

Table 3: Mechanical duty requirement of circuit breaker operating mechanisms class M1

<i>Operating Sequence</i>	<i>Control Voltage and Operating Pressure</i>	<i>Number of Operating Sequences</i>	
		<i>Circuit Breaker for Auto-reclosing</i>	<i>Circuit Breaker not for Auto-reclosing</i>
C—t _a -O—t _a	Minimum	500	500
	Rated	500	500
	Maximum	500	500
C-t-CO—t _a -C- t _a CO—t _a	Rated	250	—
	Rated	—	500

The operating sequence can be explained by the symbols:

C = Closing

O = Opening

CO = Closing operation followed by opening operation

t_a = time needed to restore initial conditions

To evaluate the operating mechanisms the opening and closing requirements and mechanisms need evaluation. This will ensure that the mechanisms functioning and the necessary requirements are explained.

2.3.1 Opening Requirements

The basic requirement for the circuit breaker opening is the speed and travelling required of the contacts to break fault currents [2]. The operating speeds are essential to ensure that the contact erosion is minimal. The fast operation also succeeds to limit the fault duration on the system.

Two pairs of contacts are needed to ensure that continuous current as well as arcing requirements are met. This states that the current carrying contact is made of highly conductive material and the arcing contact of arc resistance material such as Tungsten or Molybdenum. For this system to work the primary contacts (continues current contacts) must open before the arc resistant contacts, thus resulting in an extended life. The resistance and the inductance of the different paths are different, but this does not cause the current commutation to be instantaneous. A time delay in the design of the contacts ensures the continuous conducting element is removed from the arc

path. The worst case of a malfunction is the possibility that the current commutation only happens at the next current zero. This may cause arc erosion, and possibly dielectric failure.

The specification of contact material is more than a study of the material in itself. The material has to carry the continuous current without overheating, deterioration and with limited power consumption. Further requirements include the resistance of the material that must be as low as possible and the contact area maximized by design and force applied [3]. The design for the cross section and mass of the contacts must still be optimised for the specific circuit breaker and speed to ensure limited erosion to the contact surface.

Contact erosion caused by arcing is due to the vaporization of the anode and cathode contacts. The rate of erosion caused by arcing differs for each material type, due to various softening and melting temperatures. This can be seen in Figure 20 for various materials tested. The materials are plotted in order of excellence and serves as a comparison between theoretical calculations and practical results [3]. Although this graph suggests that the commonly used materials are less effective the combination of all aspects mentioned needs to be evaluated for the best material for the specific application.

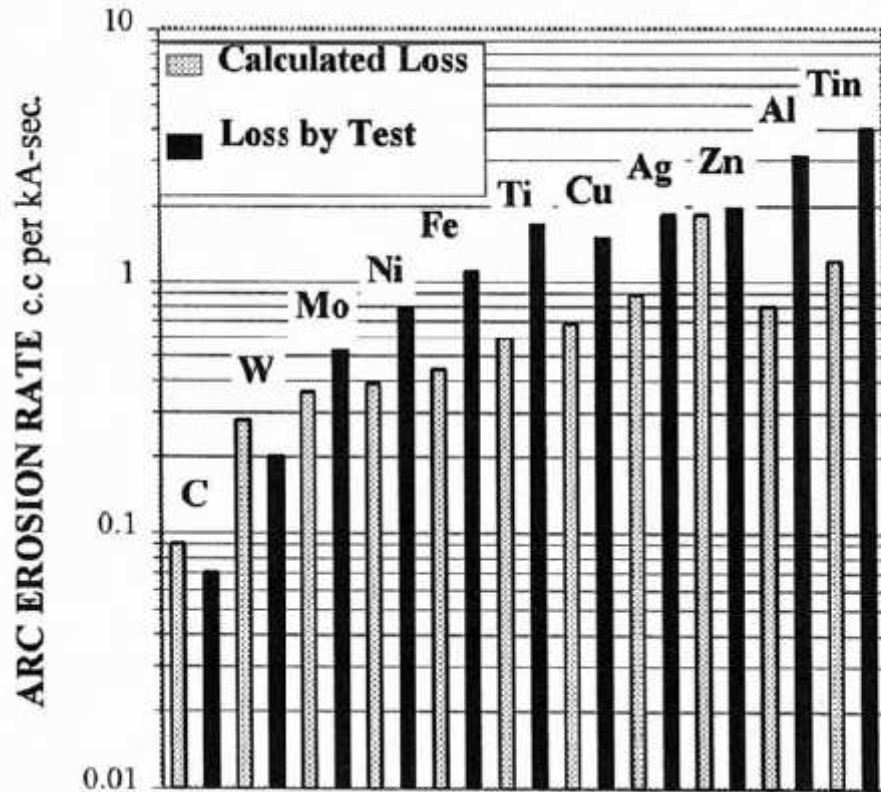

Figure 20: Contact material erosion due to arcing [3]

The calculated results in Figure 20 are based on the temperature raise due to the associated voltage drop and compared to the measured erosion from circuit breakers [3]. Furthermore, the speed of contact separation is another factor that determines the contact erosion in a circuit breaker. According to Garzon [3], the opening and closing velocities, stroke and travel distance are the most important characteristics of a circuit breaker. The velocity of contact movement is relative to the amount of erosion, or restriction of erosion required [3]. Where the stroke of movement is determined by the required dielectric withstand of the application, the contact gap is required to withstand lightning impulses [3]. The combination of velocity and stroke is needed to limit the duration of fault interruption times, and the related damage to electrical equipment. The requirements for opening are complicated by the parallel contacts. This is due to a finite time required for the commutation of the continuous current to the arcing contacts. This transfer is critical to ensure only arcing resistant contacts is utilized for interruption [3]. In the worst case this actions will only occur on the next current zero [3]. This will

result in eroding of the low resistivity material and possibly limiting the dielectric-withstand due to the vaporized ions in the contact gap of the circuit breaker. The eroding of the continuous conducting elements will result in increased maintenance intervals. The prevention of erosion of the contacts is essential. The commutation must be completed before arcing commences. For this reason the speed of the contact separation must be of such a nature that the moving contact is past a critical point outside the arcing area. Another critical element for opening requirements is the circuit breaker stroke. The stroke is required to reach a critical point, in the shortest possible time, needed to possibly eliminate the re-striking of the arc. The distance needed to interrupt and withstand the rated voltage levels are less than the maximum voltage withstanding requirements. The contacts can thus separate even further than the critical point for interruption to eliminate failures in overvoltage conditions.

This area of the stroke is required for the deceleration of the movement and the required distance to withstand rated overvoltage levels [3].

2.3.2 Closing Requirement

The requirements of the closing operation are [2]:

- Contacts closing in the required time to limit arcing and arc contact damage.
- Supply of energy to overcome repulsive force of spring or the energy storage devices.
- Have required energy to suppress fluid or displace gas in the arcing chamber.
- Additional energy required to charge opening spring mechanism

One of the critical elements of a circuit breaker is an energy storage or delivery device, with short reaction times. In the modern circuit breakers, this medium is normally spring, pneumatic or hydraulic operated. Of these three types of operating mechanisms, the spring mechanism is regularly used in

bulk oil, vacuum and SF₆ circuit breaker applications. Hydraulic and pneumatic mechanisms are found in the faster operating HV circuit breakers.

- a. With the spring types of mechanisms the energy is stored in closing springs. The stored energy is used to close on command with the release of the closing hatch [2]. The main parts of the mechanism are a charging motor and ratchet, a closing cam, closing springs, tripping springs and a toggle linkage. The motor and ratchet combination utilized to recharge the closing springs directly after the closing operation. These parts can be seen in Figure 21.

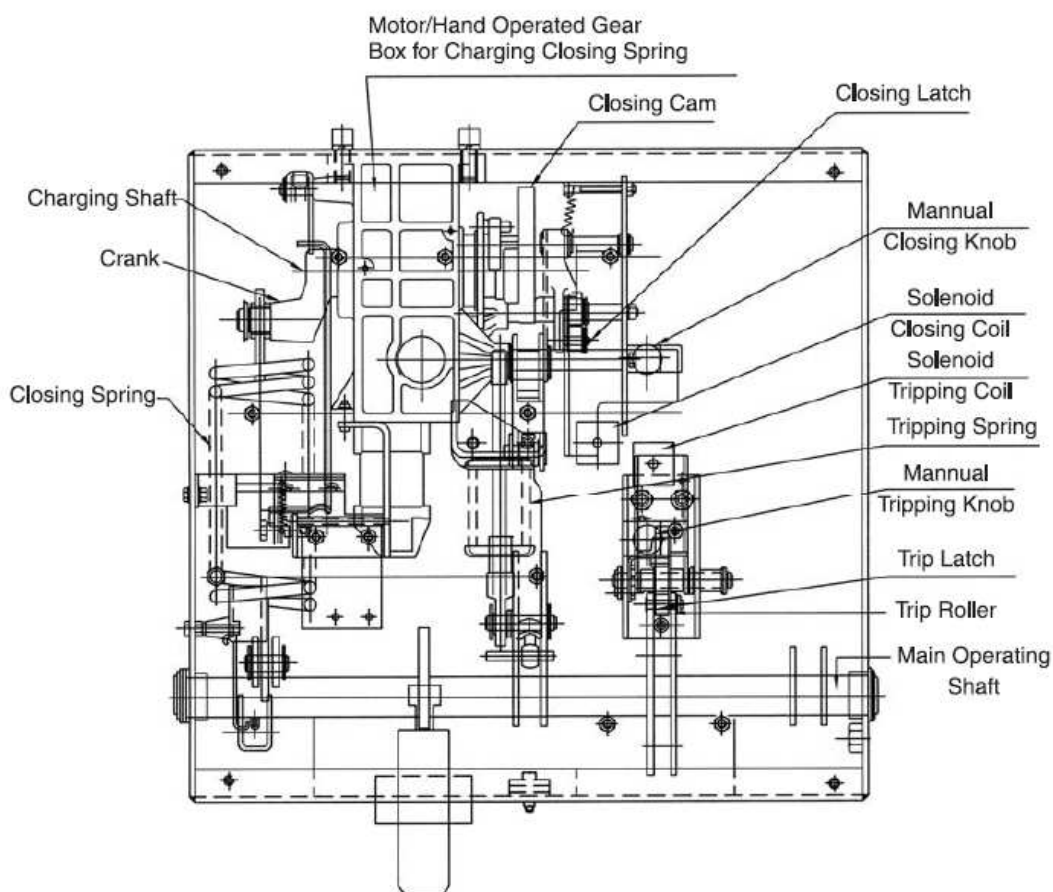

Figure 21: Graphic demonstration of the basic parts of a spring type mechanism [2]

The closing and opening operation can be understood easier when Figure 21 is used. By the release of the trip latch the trip roller carrier moves forward.

The tripping spring bias causes this movement, and opens the circuit breaker contacts.

Pneumatic mechanisms are used mostly in first generation air-blast breakers due to the accessibility of pressurised air. These types of mechanisms use air pistons to drive the closing linkage and to charge the opening springs. In Figure 22 a typical pneumatic mechanism can be seen used in practical circuit breakers.

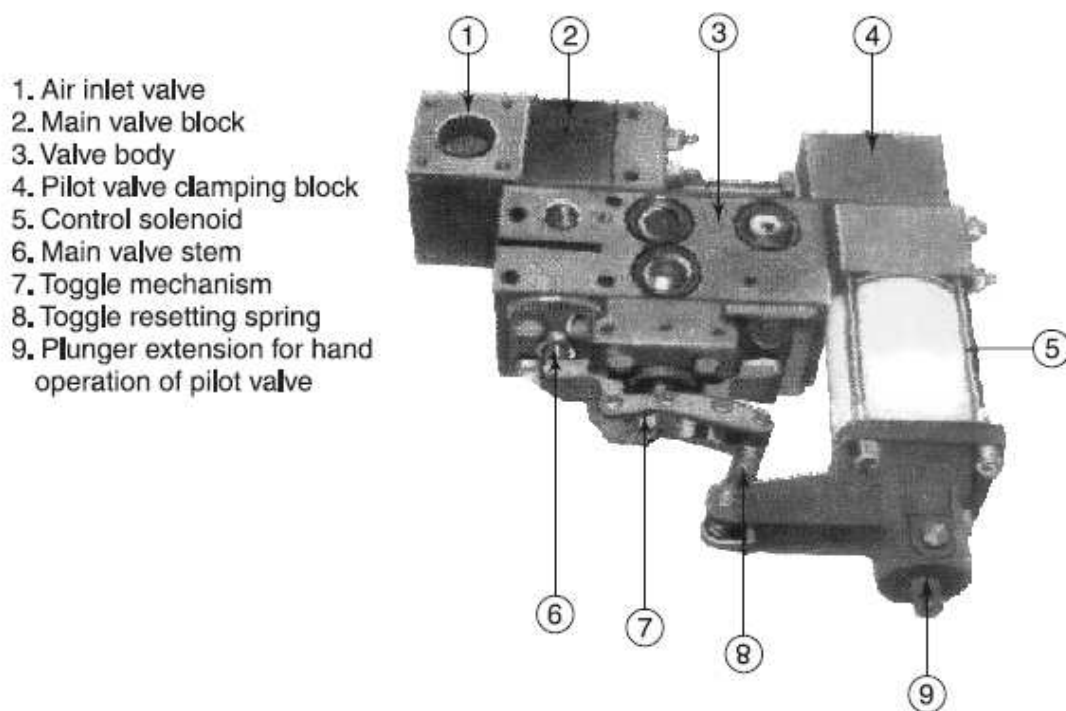

Figure 22: Pneumatic mechanisms [2]

Table 4: Characteristics of Circuit Breaker operating mechanisms [2]

Sl. No.	Feature	Spring	Hydraulic	SF6 Dynamic	Pneumatic
1	Energy stored	Medium	Very high	Medium	High
2	Mechanism fluid monitoring	—	Required	Required	Required
3	Noise	Medium	Low	Medium	High
4	Mechanism fluid leakage	—	Operation affected	Operation affected	Operation may be affected
5	Corrosion of components	May be present	Not present	Not present	May be present
6	Cost	Low	High	Medium	Medium
7	Interposing mechanism	Required	Not required	Not required	Required
8	Damping device	Required	Built-in	Built-in	Required

In Table 4 a comparison of available circuit breaker mechanisms are evaluated with some characteristics. Most manufacturers prefer hydraulic or pneumatic mechanisms for high-energy requirement circuit breakers, such as second-generation single-pressure SF₆ gas circuit breakers [1]. However, with the development of self-blast interrupter designs the spring mechanism is still the preferred mechanism. This favouritism is due to the fact that spring mechanisms require minimal monitoring and low energy levels are required for operation.

Although the spring mechanism is one of the oldest forms of operating mechanisms, new requirements of circuit breakers have not passed the capability limits of their use. As circuit breakers are required to be reliable in all typical and abnormal conditions, the designers regularly prefer trusted mechanisms. Thus, the in-depth knowledge of spring mechanisms and the relative simplicity of operation, still result in it being the mechanism of choice. This mechanism can be applied to most types of circuit breakers used in power systems. Variations within the different circuit breakers make them suitable for operation as generator circuit breakers or other specialist applications. These advantages and drawbacks will be discussed in the following section. The aim of the descriptive analysis of the types of circuit breakers is to evaluate the characteristics of all types of breakers when used as generator circuit breakers. This will be done by the analysis of the historic developments, operation requirements, developments, and finally the practicality of operating as generator circuit breakers. Types of circuit breakers evaluated include air, vacuum and SF₆ circuit breakers.

2.4 SUMMARY

In the preceding sections all the technologies available for circuit breakers were discussed in limited detail. From this evaluation of technological literature, the possibility of implementing these technologies in a generator circuit breaker application were determined by the evaluation of the advantages and the restrictions of each type of breaker.

Furthermore, this evaluation serves as introductory basis to establish possible impacts on the power station due to limitations in design and capabilities of certain braking technologies. By the evaluation of air circuit breakers the main characteristics impacting on the inclusion in generator circuit breaker applications was determined. The limitations include restrictions under increased voltage conditions and the advantage of switching in asymmetrical conditions with effectiveness and reliability was depicted. This advantage is restricted by the impact on initial capital cost due to size (civil design) and equipment cost requirements. The aged technology also requires high maintenance resulting in pressure on plant availability and relies on the correct functioning of energy intensive operating mechanisms. Safety risks was detrimental to the use of these breakers due to the release of dangerously hot gasses on fault interruption. Irrespective of these impacts, the air blast type breaker is still in use today in large generating stations, with long life and reliable operation. This type of technology is only used in modern applications above the 200 kA breaking capacity mark as this is the current limitation of SF₆ technology.

Oil circuit breakers are less used in generator applications and have been replaced with new technology devices. The associated risks of fire and the environmental impact restricts the possible applications. Minimum oil breakers are less sensitive to ambient thermal changes, but more restricted on voltage peak and pre-arcing conditions. Oil circuit breakers are still regularly found on the high voltage side of generator transformers and were therefore included.

Vacuum technology is accepted as the technology of choice up to the 100 MW level, and considered by some as the ideal interruption medium. Limitations are restricted to some additional compensation for high frequency current switching, high values of contact pressure required for low energy losses in closed state, and the occurrence of contact welding is possible on closure of contacts. Advantages in the use of vacuum in generator circuit breaker applications are the low energy dissipation in interruption resulting in

no contact erosion. This in turn resulted in the development of “sealed for life” type breakers with no servicing required. This increases the possible availability of a power plant and with the extensive expected life of a vacuum breaker the possible lifetime of a power plant protection system.

Finally, the preferred and regularly implemented technology in modern power stations is the SF₆ type circuit breaker for generator applications. With applications from the medium voltage high current to ultra high voltage applications this can be described as the preferred modern circuit breaker technology over the entire range. With limited arc energy dissipation and limited arc contact erosion this breakers can also be designed as low maintenance “sealed for life” installations. With the improvement in operating energy requirements these breakers are implemented in generator circuit breaker applications up to the 200 kA level.

All the characteristics of each type of circuit breaker technology impacts on the practicality of using it as a generator circuit breaker. These limitations either restrict or motivate the implementation in certain areas, sizes or environments. To determine the critical requirements of generator circuit breaker to function in the power system, the following section will review the critical attributes required. Practical requirements such as switching capabilities and the insulation requirements will be discussed. Final considerations will include the theoretical knowledge required in the protection field used in later sections.

Chapter 3: Generator Circuit Breaker

Literature Review

In the preceding section the design and limiting aspects of various technologies were evaluated, this background will be applied in this section to identify how these technologies can be applied in generator applications. Furthermore, this section will communicate the requirements of generator circuit breaker in practical implementation as well as the external equipment impact on the device functioning correctly. This information will finally impact on the layout and costing considerations. Operation of circuit breakers in the location directly after generator creates various difficulties for protection devices, resulting in innovations to overcome the extremes of this application. The reliability and the impact will also be evaluated for use in later sections.

The literature review of generator circuit breakers will evaluate design aspects, operational restrictions and differences from general circuit breaker applications. The operational requirements of generator circuit breakers in addition to the protection functionality are discussed. The methods utilized to prevent major failures in generator circuit breakers and the protected equipment will also be discussed. Included within this chapter is also a basic background on protection systems for power stations. This information is required for greater understanding of the multiple possible faults and serves as introductory theory for the following chapters.

This chapter finally is aimed to initialize the characterization of generator circuit breakers as a requirement or complex redundant equipment.

3.1 GENERAL REQUIREMENTS OF GENERATOR CIRCUIT BREAKERS

Throughout the phenomenal growth of power systems the demand on and the requirements of circuit breakers also increased. Some of these demands include the interruption of thermal faults, short-line faults, and out-of-phase switching as discussed in the preceding sections with each type of circuit

breaker. Another requirement of modern circuit breakers, including generator circuit breakers, is the influence of transformer magnetizing currents, reactor currents and capacitor bank currents. These elements will be discussed in more detail as they impact and influence the operation and design of generator breakers.

Low magnitude inductive currents in transformer no-load and reactors switching can cause severe stresses on switching devices. Due to the pressurized operating mechanism of circuit breakers, switching such low magnitude highly inductive current can cause premature current chopping. Current chopping is the phenomenon of forcing current to zero before a natural current zero. This in turn results in extreme overvoltages on the transformer side of the breaker.

These overvoltages are caused by an abrupt interruption of the current. The electromagnetic energy is converted into electrostatic energy, resulting in possible re-strikes and re-ignition within the breaker. This re-strike will immediately be chopped again and result in further overvoltages and the cycle will repeat. The overvoltage will decrease, due to energy lost by the re-strike. Overvoltages of 2.5 to 3.5 times the rated voltage can be expected in such situations.

Reactor current has even harsher effects as no hysteresis and limited I^2R losses reduce the impact. The risk can be minimized by the use of self-generated pressure circuit breakers, as these breakers generate breaking pressures directly proportional to the current being interrupted. Typical examples, as discussed in chapter 2, are air blast and second generation SF₆ generator breakers that are regularly applied for this reason. The installation of surge arrestors can also assist with the limiting of the overvoltages. This device increases the damping within the arcing circuit and allows the transformer energy discharge to dissipate through this device. Under normal conditions, it is possible to prevent surges by installing surge arrestors with the transformer installation.

Gas-blast circuit breakers have less frequent extreme overvoltages than minimum oil circuit breakers as self-generation of breaking pressure restricts current chopping. Although this is true, current chopping is still associated with SF₆ and minimum oil circuit breakers. Air blast circuit breakers on the other hand are regularly used in high asymmetrical current circuits for their ability to limit the effects of current chopping and resulting overvoltages.

The development of medium voltage circuit breakers has come a long way from the initial mercury dipper rods used by scientists. Development went through bulk and minimum oil circuit breakers in the 1920 to 1970, the SF₆ circuit breaker in the 1940s and the vacuum interrupt medium in the 1960s. In the current demanding global market, the most desirable arc quenching mechanism for medium voltage remains the vacuum breaker. This is mainly due to the affordable price, ease of handling and improved arc interruption of the modern vacuum interrupter. However, for high power applications SF₆ circuit breakers is most often used as discussed in chapter 2.

Throughout the design of any circuit breaker, not only the interrupting medium dictates the current rating, but considerations include thermal aspects, resistance to corrosion and conducting material.

Thermal limits of materials used within a breaker include the conduction materials, the insulation limit and the current ratings of breakers. These limitations on the current is mainly due to the I^2R losses resulting in temperature rise, and ensuring that the temperature rise is within limits of materials under fault current conditions. Evaluating the design of circuit breakers for temperature rise within the confined space of the circuit breaker is essential to prolong life and successful interruptions.

Future design considerations include the restriction of resistance variation due to corrosion of conducting material. Corroding material causes the electrical resistance is increased resulting in a greater temperature rise. Currently Copper and Aluminium are the materials of choice for carrying current within

circuit breakers. The use of any one of these materials within an application is specific and depends totally on the application.

Copper has lower resistivity, while aluminium has lower specific gravity. To elaborate, in any space limited application copper will be used, but where circuit breaker movement and cost implications are of concern aluminium conductors will be used.

Conductor plating can also be used to prolong life. Commonly used materials are Silver and Nickel, as this protects the conducting material against corrosion and limits temperature rise.

Care should be taken to ensure that the electrical resistance of the circuit breaker current carrying path is as low as possible, as this will in normal operating conditions result in higher thermal stresses and lower the life of operation.

Design aspects should also consider the effects of interrupting short-circuit currents [2].

$$\Delta T = \frac{(I_{RMS})^2}{A(1+k)} \quad (3.1)$$

A good insulation design limits the possibility of flashovers with the added benefit of increased safety for personnel and increased reliability. As this device is used in series with the generating unit the increase in reliability directly affects the reliability of the power station as a whole. Insulating material is used between any current carrying equipment and earth, within the contact gap in breaker open position as well as between phases in multi-phase systems.

Commonly used gasses in generator circuit breakers are air and SF₆. Air and SF₆ are used as interrupting medium. When SF₆ is used as insulating medium the system is referred to as Gas Insulated Switchgear (GIS).

3.2 GENERATOR CIRCUIT BREAKER

This type of circuit breaker is practically found between the generator and the step-up transformer in generating stations. The load requirements of these breakers are usually between 50 MVA and 1 800 MVA, and the primary goal is to protect the generator and transformer in a fast, economic and reliable way. The operation of the circuit breaker is complicated by the need for these circuit breakers to be able to carry a high load current ranging from 6.3 kA to 40 kA. These circuit breakers should also be able to break enormously large short-circuit currents, of up to 275 kA. These circuit breakers belong to the medium voltage range, but due to the high transient recovery voltage (TRV) the principles of high voltage circuit breakers design should incorporate . The X/R ratio of the fault current may also be very high and exceed the requirements of general purpose circuit breakers.

Another requirement for generator circuit breakers is the direct performance implications to the generating plant, increasing the need for reliable and repeatable operation. The availability of a power plant is thus an essential performance indicator, and with a generator circuit breaker included within a generating system the differential protection zones ensures maximum selectivity [9]. This ensures that generator fed short-circuit current is interrupted within 40 ms and limits damage to the step-up transformer [9]. These requirements are aggravated due to the possibilities of switching out-of-phase currents or low power factor loads. An advantage is the relative ease of synchronisation on the generator voltage level in relation to synchronisation on high voltage levels [10].

Associated with the lower voltage levels, is the extreme high current levels continuously carried by a generator circuit breaker. This breaker must also be able to break generator, system fed short circuit, and system fed short circuits within the shortest possible time. The pressure build-up by breaking fault currents up to 200 kA, can result in premature failure of the device [9]. Therefore, the overpressure relief valves are essential for generator breakers to limit the mechanical damage associated with pressure build-up. The

alternative to high pressure is the lack thereof. This can occur with breaking of small currents and thus the normal puffer principles still needs to exist to overcome this problem [9].

The most important components of a generator circuit breaker is the arcing contacts. The design and construction of this device is critical to the lifetime of the generator circuit breaker. This contact material has to withstand the repeated plasma conditions over the lifetime of the breaker [9]. This material should also not vaporize with the arc exposure as this will contaminate and degrade the insulating gas. Further design complications also includes the mechanical reliability as important criteria. These devises have to stay dormant and ensure minimal current losses by the balance of repulsive and attractive forces, or anti-parallel and parallel paths [9]. The materials used should be highly electrical and thermally conductive. This can be seen in Figure 23 as a representation of one fingers of the arcing contacts used in a generator circuit breaker. The finger segments in Figure 23 consist of a connection flange (1), contact finger (2), connecting part (3) and the arc resistant tip (4).

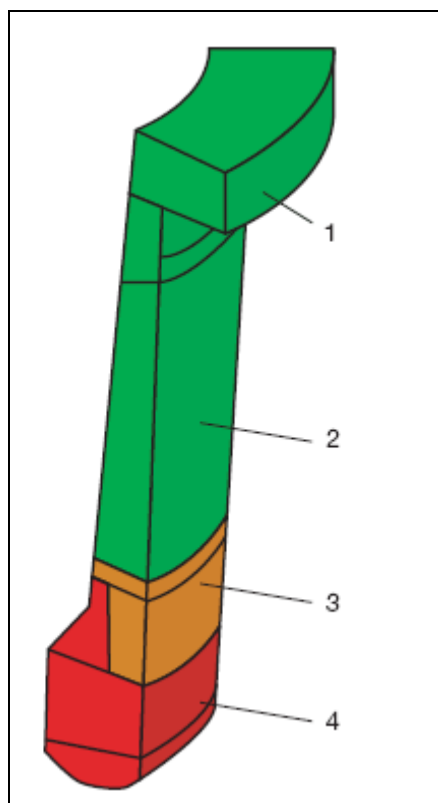

Figure 23: A finger of a segmented arcing contact system [9]

Typical materials used for sections 1 and 2 are the spring copper alloy (CuCrZr) while the arc resistant tip is made of a tungsten-copper composite and the connection made of copper.

To extend the life and the capabilities of a generator circuit breaker are thermal aspects of normal and fault conditions need consideration. The heat generated by the continuous current through the device must be less than the capability of the insulating resins to withstand heat. These effects can be limited by using a design optimised to limit heat generation, using an external housing to dissipate heat through cooling fins, and using an encapsulated design to limit external field strength leading to heat generation [9]. This generated heat can limit the life of a circuit breaker dramatically due to the degrading of the insulation. New insulation materials have been developed to withstand temperatures of 105 °C for 30 years [9].

One of the greatest differences between generator breakers and other medium voltage circuit breakers is the effects of the X/R ratio of the system. This creates a high DC components within the fault current causing the current not to pass through zero [11]. As all circuit breakers are rated through their rated symmetrical current at a maximum X/R ratio of 17, any system with higher X/R ratios require special consideration. The X/R ratio partly determines the needed opening time, maximum RMS current and the time constant of the system, and is a critical requirement associated with generator circuit breakers as high X/R ratios are regularly associated with faults close to large generators. High X/R ratios can cause high alternating current exponential and DC components in the current. To ensure the generator breaker specified in the system is designed to withstand and is capable of interrupting the system faults, the rating of the breaker must be adapted to the system conditions. The asymmetrical components can be used to calculate the correction factor to specify the correct generator circuit breaker.

Further initiatives used to extend life are the introduction of condition monitoring of the arcing contacts. This is calculated by the arcing time and

the fault current interrupted, as this will predict the damage done to the arcing contacts. This will eliminate the unnecessary shutdown times due to scheduled maintenance. The differences in requirements between a generator circuit breaker and a medium voltage circuit breaker are shown in Table 5 [11]. The main difference is the percentage DC components within the fault current. Initially the current may not pass through zero. This results in difficulties in breaking the fault current, and prolonging the needed breaking times of the generator circuit breaker.

Table 5: Comparison between requirements of circuit breakers [11]

Parameter	Requirements for generator circuit breaker	Requirements According to IEC 56
Switching of system fed short circuit currents:		
-Breaking Current	Isc	Isc
-DC-component (%)	70 - 80	25
-Recovery Voltage (kV)	0.87	0.87
-Rate-of-rise of recovery voltage	3.5 - 5.0	0.47
-Time delay (μ s)	<1	13
-Peak value (kVpeak)	1.84	1.72
Switching of generator fed short-circuit currents:		
-Breaking Current	0.4 - 0.8 Isc	0.6Isc
-DC-component (%)	100 - 130	not specified
-Recovery Voltage (kV)	0.87	0.87
-Rate-of-rise of recovery voltage	1.6 - 2.2	1.16
-Time delay (μ s)	<0.5	8
-Peak value (kVpeak)	1.54	1.84
Switching under out-of-phase conditions:		
-Breaking Current	0.4 - 0.6Isc	0.25 Isc
-DC-component (%)	80 - 100	not specified
-Recovery Voltage (kV)	1.23	1.44
-Rate-of-rise of recovery voltage	3.3 - 5.2	0.25
-Time delay (μ s)	<1	not specified
-Peak value (kVpeak)	2.6	2.55
Switching of load currents		
-Breaking Current	I _r	not specified
-Recovery Voltage (kV)	0.43	not specified
-Rate-of-rise of recovery voltage	1.0 - 1.6	not specified
-Time delay (μ s)	< 1	not specified
-Peak value (kVpeak)	0.92	not specified

3.3 GENERATOR OPERATION MODES

Beyond the normal operating conditions of conducting load generator current, generator circuit breakers are also required to synchronise the generator with the system and in other cases switch no-load currents. This is critical as the overvoltages resulting from closing an unloaded line, opening an isolating switch and breaking low inductive and capacitive currents can cause damage to equipment when switching circuit breakers overvoltages may occur, but can be controlled by external or internal devices to limit these effects on insulation systems [3].

When closing of any circuit breaker within a system the load, and parameters of the network, changes resulting in the “shift” in the power system to accommodate these changes. The equipment connected by the circuit breaker may have trapped electrical charge causing overvoltages within the system. This can occur with a fast re-closing of a transmission circuit breaker, resulting in overvoltages within the system that can possibly damage the circuit breaker in an open position.

Switching a line fed from the step-up transformer causes a transient voltage of a single frequency and at double the magnitude of the system voltage on closing the circuit breaker [3]. This is further complicated in any system feeding parallel lines or transformers. The factors that have an effect on the overvoltage are the length of the line, high source reactance, number of parallel-connected lines, and any power frequency increase that will increase the overvoltage due to switching unloaded lines. Another situation where trapped charge could cause overvoltages is the re-closing after fault clearing. When a single line-to-ground fault occurs there is significant electrical charge stored on the other phases. The line functions as a capacitor and with the reconnection of the disconnected system the resulting overvoltage could be severe [3].

Overvoltages can occur by interrupting small currents, as the capability of the circuit breaker is much greater than what is needed in short-circuit fault conditions. Interrupting of small capacitive currents can cause the breaker to interrupt the current while the distance needed to prevent a re-strike or re-ignition has not been reached. This will result in the recovery voltage over the breaker to breakdown the dielectric medium of the breaker [3]. This is due to the energy stored within the capacitance and the source side voltage of the breaker oscillates according to the system frequency. After the current reached zero, assuming peak voltage within the system due to capacitive load, the load side voltage will continue oscillating and reach the maximum amplitude at reverse polarity a half cycle later. This will result in a 2 p.u. to 2.5 p.u. voltage over the open contacts of the breaker depending on grounding configuration of the capacitive load of the network.

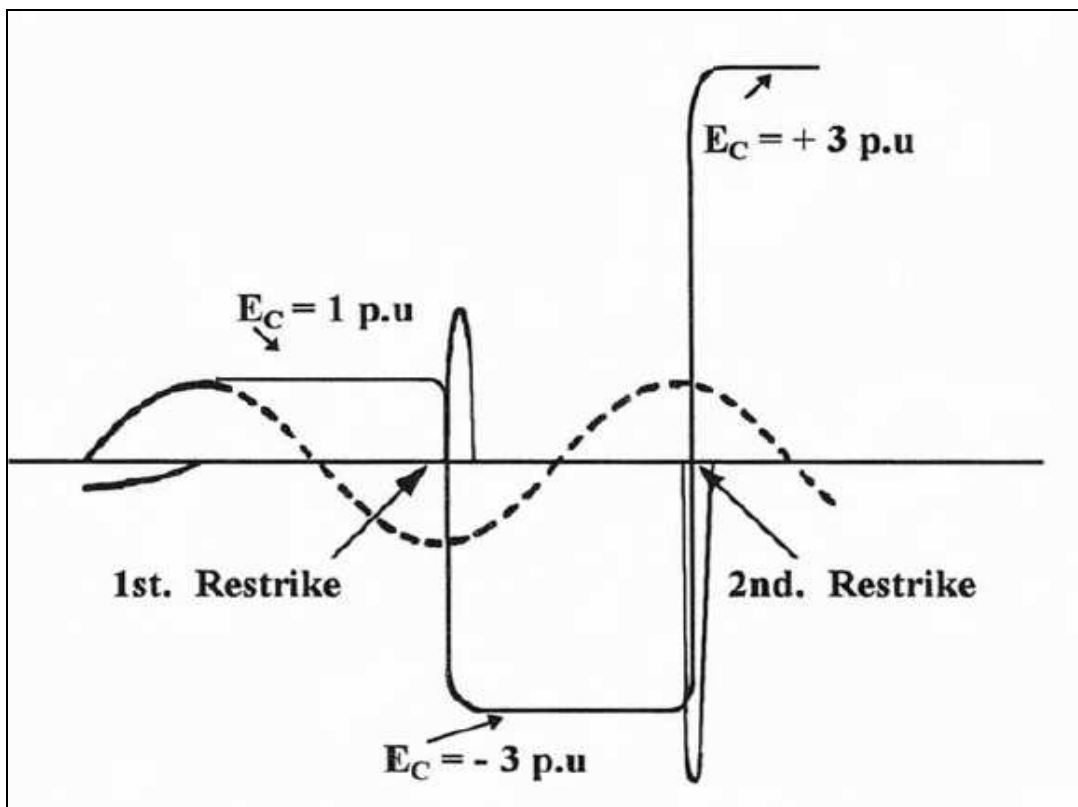

Figure 24: Voltage escalation due to restrikes during capacitive load switching [3]. Note: E is used for voltage in this graph.

As can be graphically seen in Figure 24, a re-strike will result in an in-rush current (depicted by peaks at voltage polarisation change in Figure 24), due to

the inductance within the system and aim to swing the capacitor voltage to the system voltage. Within Figure 24 the label E_c depicts the relative differential voltage between the system neutral and opened circuit breaker contact. This variable can be exchanged for either U_c or V_c . A second interruption on the following zero crossing of the applied voltage on the capacitor will be 3 p.u. and result in an applied voltage of 4 p.u. over the opening circuit breaker contacts assuming no damping within the system [3]. This can result in damage to the circuit breaker, capacitor or unloaded line due to severe overvoltages applied to the system. E_c depicts the voltage over the circuit breaker contacts, and the sinusoidal the system voltage.

The same scenario can be applied to switching low inductive currents with a greatly oversized circuit breaker. This will also cause the current to be interrupted while the contacts are not sufficiently separated to withstand the recovery voltage, but due to the expected damping within the system the overvoltages will under normal conditions not exceed the 2 p.u. level. Although breakers that can interrupt the high frequency re-strike or re-ignition current, it can cause the build-up of magnetic energy within the system inductance load, while the contact movement advances, creating the opportunity for a re-strike to occur at higher voltage levels. This can occur after the high frequency re-strike is interrupted and the system voltage is recovering over the contacts. This can then result in another re-strike. These consecutive re-strikes can cause the build-up of energy stored within the inductance of the load and results in the cumulative rise in overvoltage within the system. Examples of such occurrences can be seen in Figure 25.

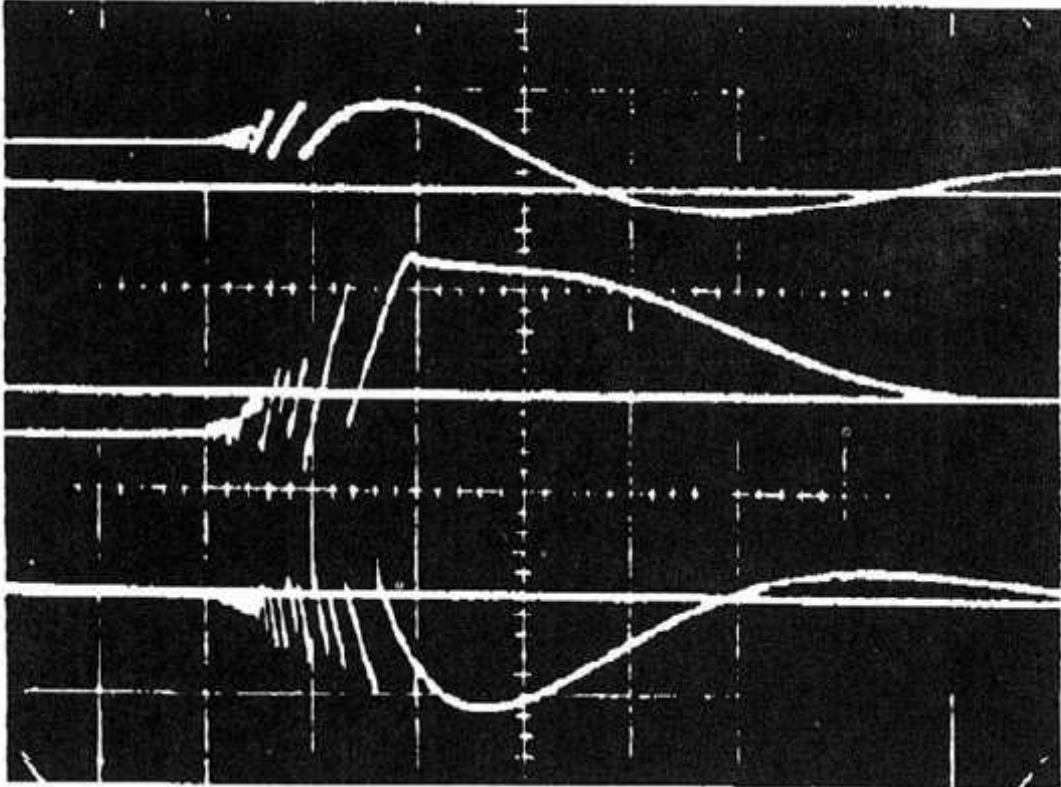

Figure 25: Voltage surges (p.u.) per time unit caused by consecutive re-strikes while interrupting inductive currents [3]

Beyond the opening under fault conditions and opening and closing under no-load conditions, generator circuit breakers need to be able to withstand electromagnetic stresses due to downstream faults without opening. Electromagnetic stresses can be caused by the voltage changes attributed to the loss of load and the stabilization of the systems active and reactive power components.

Generator circuit breakers are required to switch to very high X/R ratio currents resulting in additional stresses on the breaker. This can be overcome by over-rating generator circuit breakers according to the asymmetrical requirements and not on a symmetrical current basis. The ac and dc asymmetrical current contributions cause the breaker to be operated beyond the symmetrical current capability and an assumed X/R ratio of less than 17 [3]. The dc asymmetrical component can also cause the current not to go through a natural zero, thus prolonging the fault interruption times or

causing current chopping and overvoltages. Breaker specifications for systems with X/R ratio systems higher than 17, must be specified by evaluating the asymmetrical components and adjusting the symmetrical rated current accordingly.

3.4 BASICS OF GENERATOR STATION PROTECTION

As a power station is one of the critical components requiring maximum availability within a power system, the interruption of fault conditions and the protection of its equipment are of utmost importance. The size and complexity of the equipment also demands comprehensive protection as the replacement and/or repair of any single unit is a major cost and very time consuming. The protection of the generator as well as the generating station components will be briefly described and only selected components are explained in detail.

Generator Protection

Generator protection can be seen as the risk mitigating actions to limit the failure of the generating equipment. The aim of generator protection is to limit or restrict any fault conditions occurring within the generator itself. In a power station where a generator circuit breaker is included, this can be used to increase the degree of protection. This can improve fault interruption on the step-up transformer, and subsequently improving the response and isolation of generation faults. The interruption of fault current before the step-up transformer can restrict the consequential faults in the transformer. This also applies to the unit transformer.

One of the critical protection systems for a generator, step-up and unit transformers is differential protection. This protection is normally based on a circulating current principle and used to detect internal faults. Current transformers are connected to both sides of the unit [12]. As the summation of all currents flowing through the stator winding must be zero, the differential relay detects the spill current in this circuit. A practical application of this principle can be seen graphically in Figure 26.

The generator stator windings can be earthed by various high or low impedance grounding devices or by direct grounding techniques. The use of any one of these options depends on the specific generator in question and the power station protection requirements. Most stator earth fault protection systems protect 90% to 95%, with some limitations close to the neutral point [4].

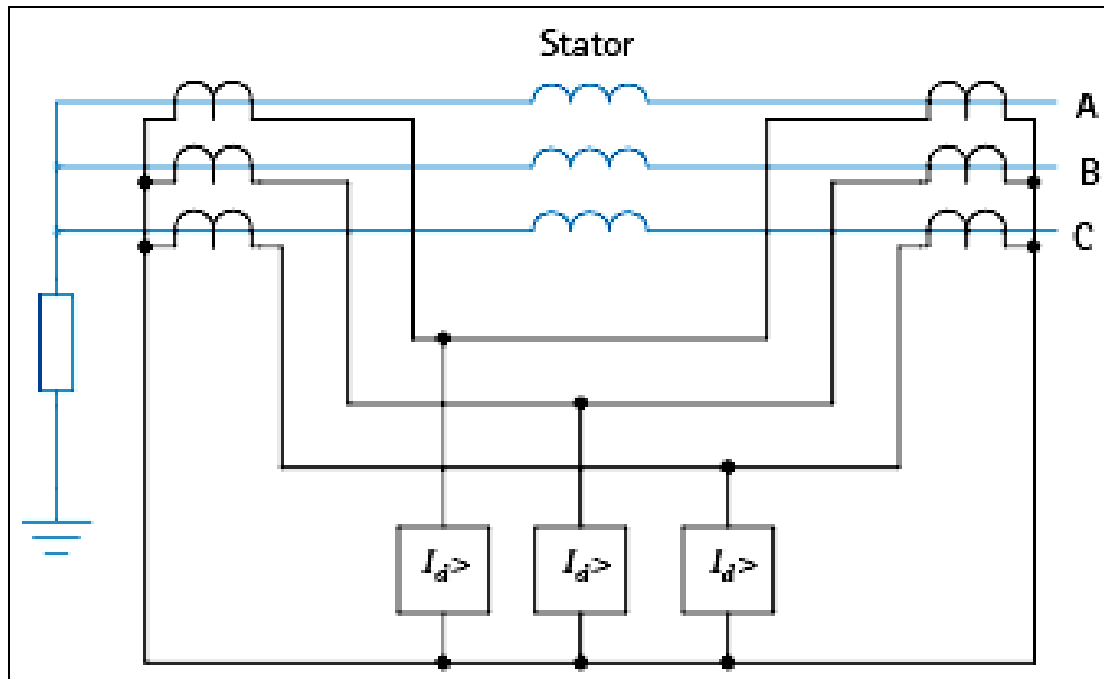

Figure 26: Stator Differential protection [13]

In a unit configuration where each generator has its own step-up transformer the differential protection of the generator and the transformer can be combined in one protection scheme. The requirements of the generator protection relay are increased to include the transformer protection system. This is used to cover the generator step-up and unit transformers, and provides redundancy in the protection system.

Differential protection is used as a rapid response protection function with limited time delay. The normal overcurrent protection functions in protection relays are used to distinguish between close and distant faults within a power system, regularly called voltage controlled overcurrent protection [13]. By monitoring of the current and the voltage the fault position can be determined.

In the case of close-up faults, the voltage of the system will drop dramatically, but distant faults will only result in the overcurrent and not a voltage drop. This distant fault must be withstood by the limitations of the power station's short time withstand characteristic.

System transient overvoltages are limited by surge arrestors within the system [13]. Another cause of overvoltages is the failure of the automatic voltage regulator (AVR). This can cause overvoltages at the power frequency. Malfunctioning AVRs with reactive load changes or load shedding, results in equipment damaging overvoltages. Overvoltage protection must trip the AVR to limit damage [13].

Modern numerical relays can also prevent the certain actions due to interlocking conditions being met [13]. This can be applied to low forward or reverse power protection [13]. Reverse power is used to prevent mechanical damage of the turbine running in motoring mode [13].

In the case where a generator is operating with an unbalanced load, the effects of the positive and zero sequence currents are limited. The negative sequence current on the other hand causes severe overheating due to the generated eddy currents within the core and the breaking torque being applied [13]. These eddy currents are generated by flux at twice the rotational speed of the generator [13]. This event can effectively be protected by the temperature monitoring of the generator in accordance with the designed thermal withstanding capacity.

Over-fluxing occurs when the ratio between the voltage and frequency changes [13]. A rise in voltage or decay in frequency or both will cause over-fluxing and a rise in temperature. The frequency is controlled by the prime-mover governor. In severe conditions, the failure of this control function can result in under- or over-frequency conditions, resulting in the emergency disconnection of the generation station [13].

Rotor faults are relatively rare and can result in severe delays due to repairs. Rotor earth faults are dependent on the type of rotor, but this can be generally evaluated by the monitoring of the rotor insulation resistance [13]. A shorted turn within the rotor can also cause severe vibrations within the generator and cause mechanical damage. The rectifying diodes in the DC field supply can also result in problems due to breakdown and the ac current within the field windings. This can easily be prevented with fuses and parallel diode bridges. In the case of a single diode failure the generator can still operate, but at limited capacity [13].

Field suppression systems can also be implemented to ensure the safe shut down of the generator in case of emergencies [13]. Another emergency situation is the loss of excitation. The loss of excitation can cause the generator to draw a large amount reactive power from the system and operate as an induction generator causing the rotor to overheat and instability in the power system.

Stator overheating can be caused due to system overloads, failure of cooling system, over-fluxing and core faults. Furthermore, mechanical faults such as over-speeding and prime mover failure can be prevented and monitored with modern systems.

Transformer Protection

Independent of various layouts used in power stations, transformers are needed in power generation. For this reason the protection of this equipment is as important as the generator protection. Furthermore, the generator circuit breaker and the impact of the implementation on the protection, can result in possible fault condition restrictions and limit the risk of step-up transformer damage. In the layouts where the generator circuit breaker is omitted, the transformer differential is extended to cover the generator as the disconnecting breaker is situated on the high voltage side. This demonstrates the complexity of interconnecting the various protection functions, rather than isolating the individual components.

Transformer faults can be classified as winding and thermal faults, core faults, tank and accessory faults, on-load tap changer faults, abnormal operating conditions and sustained or non-cleared fault conditions. The early detection of these faults can limit damage to the transformer and associated equipment.

Transformer differential protection is used to detect faults with-in the protected zone, i.e. between the sets of current transformers. Differential protection on transformers works on the same principle than on generators, except that the function must be restrained during inrush conditions. Additional specific protection systems have to be added to the unit differential protection to ensure that complete risk mitigation and nuisance trips are eliminated. One such example is the magnetizing current associated with the energising of a transformer. This will cause a circulating current within the differential system, as the incoming current is not matched on the secondary of the transformer. Transformer differential protection can employ delay protection for the energizing condition, with modern numerical protection relays.

Through transformer differential protection phase-to-phase faults and phase-to-earth faults are covered.

Restricted earth fault (REF) protection for the star connected side of the transformer will provide additional differential protection. In Figure 27 a transformer with combined differential protection and a restricted earth fault scheme can be seen.

Inter-turn faults, core faults and tank faults are covered by other specific protection functions.

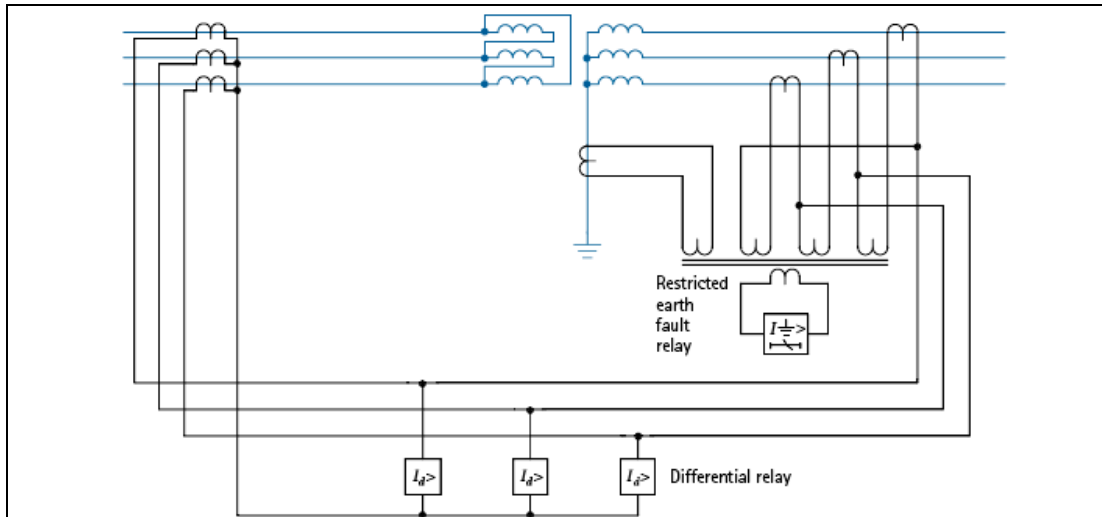

Figure 27: Configuration of transformer differential and restricted earth fault protection

The application of generation protection does not come without complication, as the transformer’s phase shift has to be reversed by the current transformer configuration. In Figure 27 this can be seen by the CT connections on the primary side, the delta side, being connected in star and the secondary side, being connected in delta. This results in the reversing of the phase shift and the obtaining of comparative currents. The multiple winding and earthing configurations can also complicate filtering the zero sequence components of distant faults fed from the transformer. The possible ratio difference of current transformers could also create problems, as with all differential schemes, as the ratio difference could cause circulating currents.

Transformer inrush or magnetizing current limits the effectiveness of differential protection during energisation of the transformer. The second harmonic current can be used to detection inrush current as it does not feature in normal conditions, but is always found within magnetizing inrush currents. This enables the differential protection to be fast acting directly after the inrush is completed. It must be mentioned that the current transformers used on the primary side of the transformer must be of adequate size to be able to withstand the transient of the inrush current, and not saturate during this time, limiting the protection functions.

The over-fluxing of a transformer can occur from overvoltage, under frequency and geomagnetic disturbances. The first two can be easily monitored by time delayed fault protection in a V/f threshold, and by DC component monitoring all geomagnetic disturbance elements can be detected.

The protection of the generating station is dependent on the generator circuit breaker and the accurate detection of faults within the system. The speed of operation of a generator circuit breaker is dependent on the protection system detecting faults selectivity and without delay. The impact of delayed detection can result in catastrophic failure of equipment. Further requirements impacting on operating speed include the operating mechanism and type of generator circuit breaker as described in earlier sections.

3.5 SUMMARY

This section clearly places the generator circuit breaker in an individual category due to the required capabilities of this device. The technological advances as motivated though the requirements of generator circuit breakers are directly achieved by advances in breaker technology. Generator circuit breakers are also cemented as a key performance indicator in power stations where they are included, and multiple considerations must accompany the installations of such a device. Beyond the civil, mechanical and initial electrical specifications, the specification of all external equipment and the configuration of the network connections needs consideration. Thermal limitations and internal condition monitoring systems also ensures that modern generator circuit breakers have lesser impact on maintenance intervals.

From the evaluation of the theory the impression is created that the use of a generator circuit breaker simplifies the protection system by individually protecting the generator and the transformer and limits equipment damage due to system faults. Furthermore, the selectivity of the protection system ensures that fault clearing can be achieved in the shortest possible time. This

possible improvement requires justification and will be further evaluated in the next section through a simulation based study of various faults on a generating station with and without generator circuit breakers. Practical restrictions as discussed in this section will be included in the simplified simulation to ensure practical and accurate results.

Chapter 4: Impact Analysis

In the preceding section multiple limitations of circuit breaker technologies and the complications in operating a generator circuit breaker were highlighted. All the theoretical analyses does not lead to concrete proof regarding the use thereof. To evaluate the feasibility of the installation multiple permutations require consideration. In a standard layout, as in Figure 34, adding a generator circuit breaker to this layout, the protection of the system changes and so also the capital requirements. To evaluate the impact of this modification a simulation of faults and the impact thereof must be evaluated. By evaluating several possibilities of fault occurrences in multiple locations the impact on the protection system with a generator circuit breaker in- and excluded can be quantified. Another factor affected by the inclusion of a generator circuit breaker is the physical layout of a power station. This definitely impacts the initial cost but may also result in changes to the system as a whole. Thus, the evaluation of all the impacts of the inclusion of a generator circuit breaker can be evaluated through a study of various layouts, and the advantages and disadvantages of any specific layout. This can be evaluated to determine the most feasible generator circuit breaker application.

This theoretical evaluation provides the study with various options, practical measurable performance indicators are used to evaluate the possibilities and determine the feasibility. This requirement leads to the evaluation of the reliability and availability of the researched layouts. This study is completed by utilizing the IEEE approved data and methods provided the required input parameters to finally determine the capital and running cost calculations.

Through “cause and effect” analysis the complete impact of generator circuit breaker implementation can be determined. By using or excluding of a generator circuit breaker in the evaluations, the conclusion thereof will include all critical components to motivate the final result.

4.1 SIMULATION

To understand the impact a generator circuit breaker has on the protection within a generating station, the situation can be simulated. The simulation was constructed with the principle idea to identify the effect various faults and the protection system have on the system performance. The layout can be seen in Figure 28 and consists of a 200 MW generator with a generator circuit breaker feeding a 250 MVA step-up transformer and a 10 MVA unit transformer. The station transformer is connected to a simulated load of the appropriate size.

The critical design elements of the power station simulation consist of:

- Generator: Power = 200 MW
Voltage = 11 kV
Rated Current = 13.13 kA
Inertia Constant = 3 s
Neutral Series resistance = 1200 p.u.
Iron losses = 1/300 p.u.
- Generator Transformer: Rating = 250 MVA
Voltage = 11 kV/400 kV
Positive sequence leakage reactance
= 0.14 p.u.
No-load losses = 0.005 p.u.
Copper losses = 0.01 p.u.
- Simulated HV Load: Resistance = 800 Ω
Inductance = 0.8 H
- Generator Circuit breaker: Open Resistance = 1 M Ω
Closed Resistance = 10 $\mu\Omega$
- Simulated Faults: single phase-to-earth and three phase-to-earth.

Fault locations = Generator terminals, primary (LV)
transformer terminals, load terminals

Fault ON resistance = 1 m Ω phase-to-earth

Fault OFF Resistance = 1 G Ω phase-to-earth

The system was simulated to reach after a steady state after 1 s, and after another 0.5 s a fault was applied to one of the locations. Depending on the location, the relevant circuit breaker will operate with a 40 ms time delay, and the other breakers 160 ms later. Within the simulated system three circuit breakers are present: the generator circuit breaker, unit transformer LV circuit breaker and the HV side circuit breaker of the generator transformer. The various faults were applied to the simulated system with and without the generator circuit breaker, thus determining the system response. The faults, named load fault, primary terminal fault and generator terminal fault were chosen to demonstrate the advantages and shortfalls of the inclusion and exclusion of a generator circuit breaker.

In the scenario where the fault applied on the load side of the high voltage busbar, independent of type of fault, the response to the fault current is similar. As the supply of the energy is isolated in similar fashion the in- or exclusion of a generator circuit breaker has limited effect. Large differences in results occur when a fault is applied on the generator side of the high voltage circuit breaker. This is due to the circuit breaker not interrupting the supply from the generator. To demonstrate the impact of this scenario, see figures 29, 30, 31 and 32. The study was conducted with a three phase-to-ground fault, and all results are plotted from 0,1 s before to 0,1 s after the fault event. This fault type was chosen as the result of a single phase fault was similar, but only lower in magnitude and less visually presentable.

In both scenarios the fault results in a dramatic decrease in system voltage and a rise in fault current. The fault current has a high DC off-set resulting in the exponential decay of the fault currents, because of the high X/R ratios in the system.

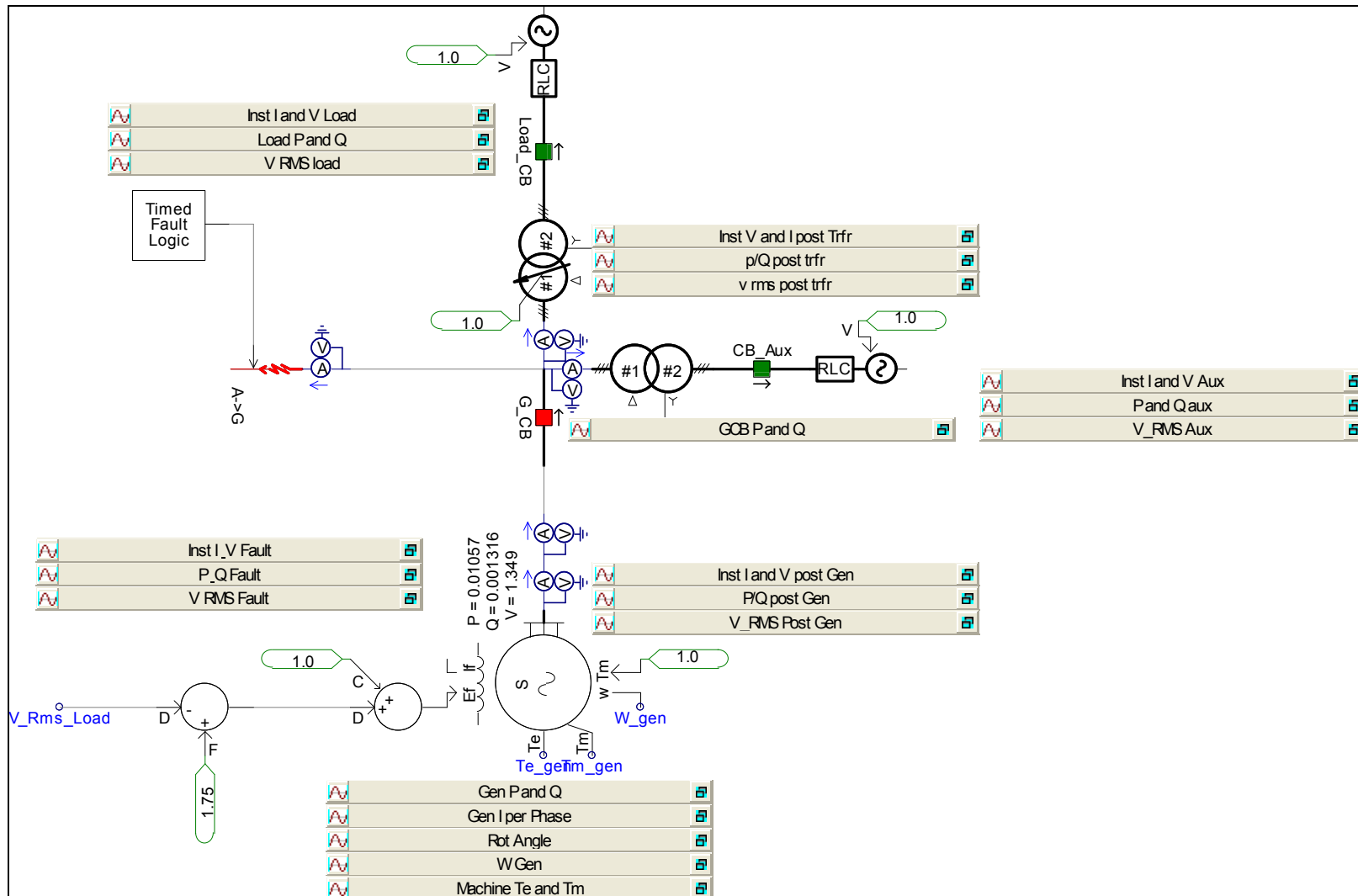

Figure 28: Generation station layout

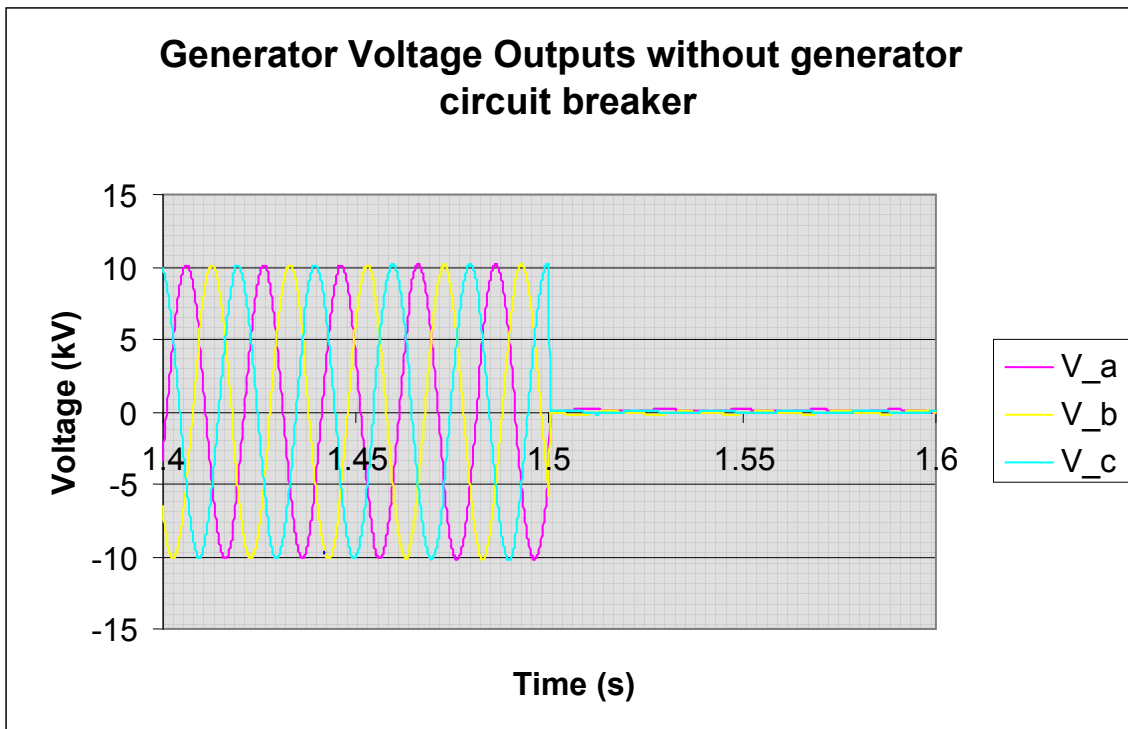

Figure 29: Voltage output of the simulated generator without a generator circuit breaker

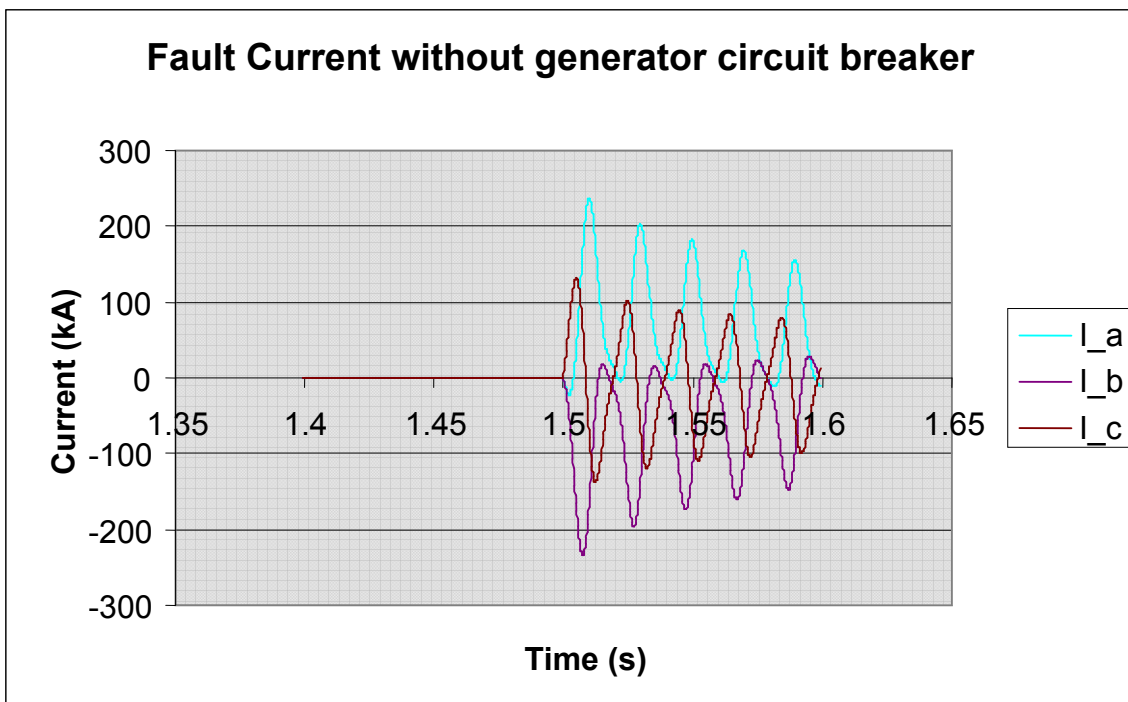

Figure 30: Simulated fault current without a generator circuit breaker installed

Figures 30 and 31 indicate that within this system a three phase-to-ground fault will result in a decrease in fault current with time. The generator and the generator transformer could possibly be damaged by such an event as the extremely high currents must be withstood for prolonged periods. The simulation results only display the decay over a 0,1 s period, but the decay will continue until the energy stored within the magnetic field of the system is dissipated.

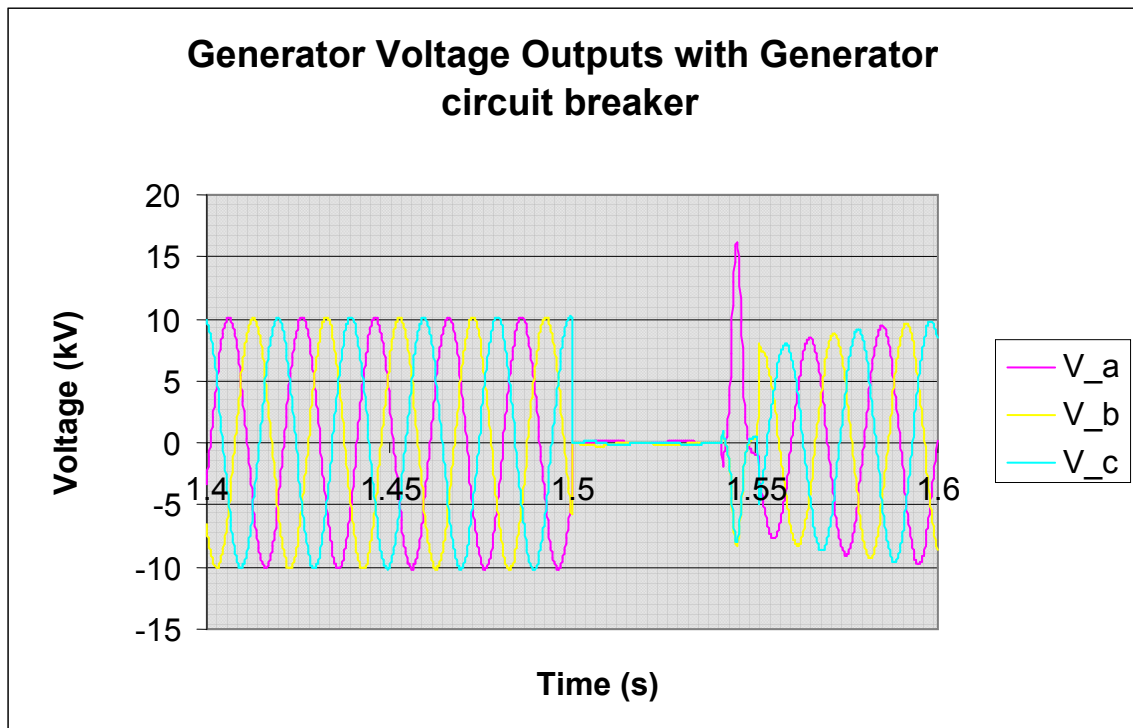

Figure 31: Generator terminal voltage with generator circuit breaker installed

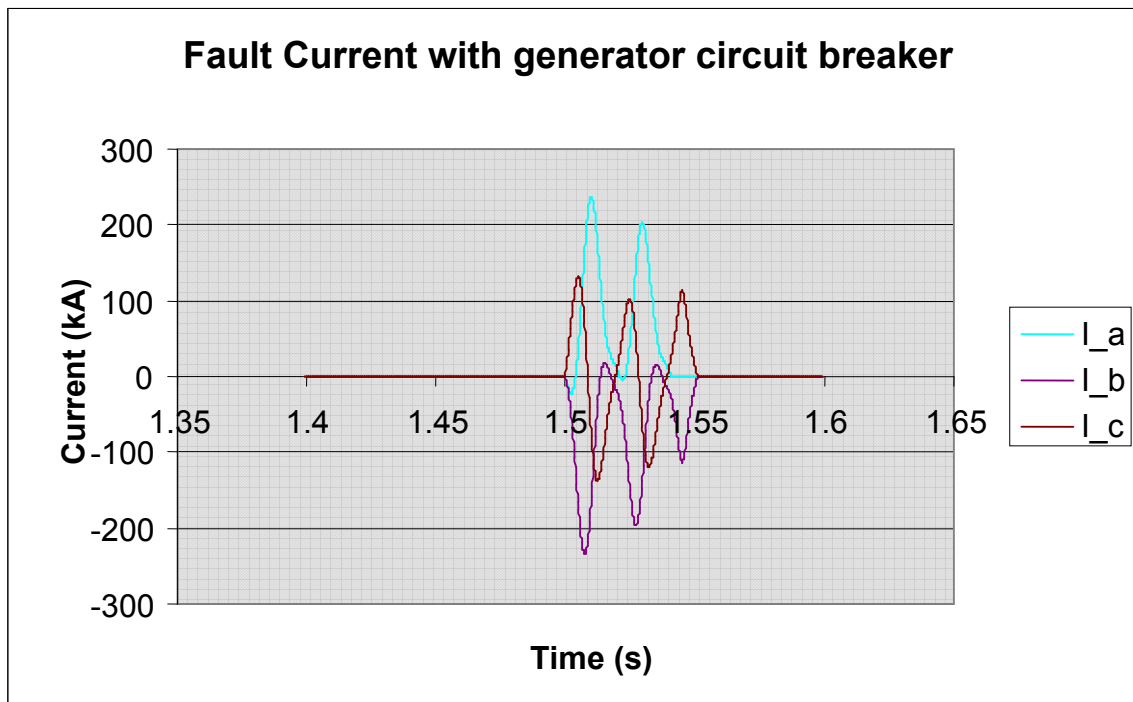

Figure 32: Simulation outputs of fault currents with a generator circuit breaker

In figure 32 and 33 on the other hand, a similar three-phase fault, results in similar magnitude fault currents, but the difference resulting from the additional protection provided by the generator circuit breaker can be seen in the duration of the fault current.

This minimizes the impact of a failure within the transformer differential zone and consequential damage to the generator also limits the down time due to such a fault. The transient recovery voltage is shown in Figure 31, as the induced overvoltage after fault is interrupted at the generator terminals. This is due to the change from loaded to unloaded condition. This causes a high transient recovery voltage (TRV) across the circuit breaker poles and may vary depending on the load conditions and can be dramatically higher. For this reason the normal rated short time voltage impulse withstand level is approximately 5 p.u. for generator circuit breakers due to the high X/R ratios close on the generator terminals.

This is not the case when the fault is on the generator terminals and when interrupted the current through the generator circuit breaker only forces the system contribution to

zero, but does not isolate the fault. In this case, the effect of generator circuit breaker is lesser but still beneficial.

For this reason, the effects of various layouts with and without generator circuit breakers should be evaluated, incorporating in addition to the protection of the system the cost, ease of operation, availability and mean time to repair of a layout.

In short, the generator circuit breaker reduces the risk associated with faults occurring between the generator transformer high voltage terminals and the generator output terminals. Furthermore the protection system can be more selective and effective through the possible use of generator differential and transformer differential protection to protect this part of the power station as was discussed in the preceding chapter. This also reduces the risk of consequential equipment failures due to prolonged exposure to fault conditions.

From the simulation results, the theoretical analysis suggests that the protection of a power system with the inclusion of a generator circuit breaker is beneficial was practically proven. Although the risk of a fault between the generator circuit breaker and the generator transformer is limited by short distances and proper maintenance practices. This proof only accounts for some motivation towards the cost of the generator circuit breaker as a power station component. The inclusion of a generator circuit breaker results in layout modifications and will be evaluated in the following section.

4.2 POWER STATION LAYOUTS

Industrial generators

The simplest form of a generating station is to directly connect the generator to the main busbars, as indicated in Figure 33.

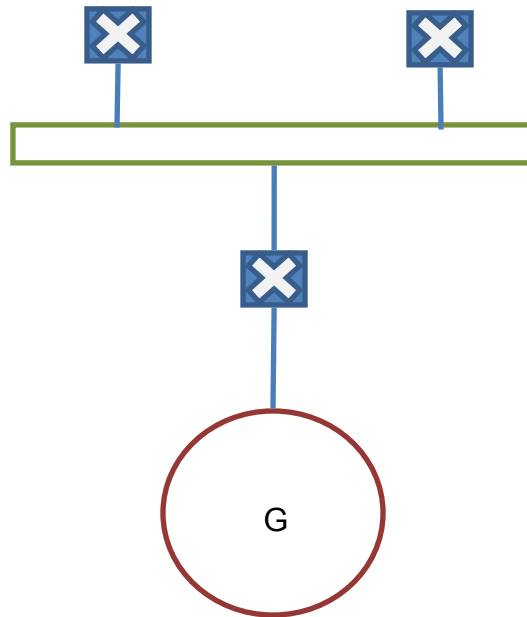

Figure 33: Directly connected generator with generator circuit breaker

This type of generator must be rated for the system voltage and a generator circuit breaker is necessary to connect/disconnect the generator to/from the system. In the case of a busbar fault, the faulty section can be disconnected from the generator and the load with breakers. If the generator cannot be disconnected, a fault current will be continuously supplied until failure of the equipment. Being without a generator circuit breaker is impractical as the entire busbar must be isolated to maintain the generator and associated equipment.

The generator can be protected with a generator differential, earth fault, over- and under-voltage, reverse power, negative sequence current, under- or over-frequency, over-fluxing, rotor faults, pole slipping, and thermal protection.

Thermal Power Stations

In Figure 34 a thermal power station layout can be seen without a generator circuit breaker. In this configuration, or a similar derivative, the areas where differential protection is needed are four transformer differential sections. This is due to the three transformers each having their own differential zone and the overall differential zone that includes the generator, the generator transformer and the unit transformer. A generator differential zone is not needed, since the generator cannot be isolated from the system. Within a unit configured system the station transformer usually supplies

auxiliaries on start-up or shutdown of the generator unit. These transformers can also be utilised for various units in a power station, resulting in a cost saving.

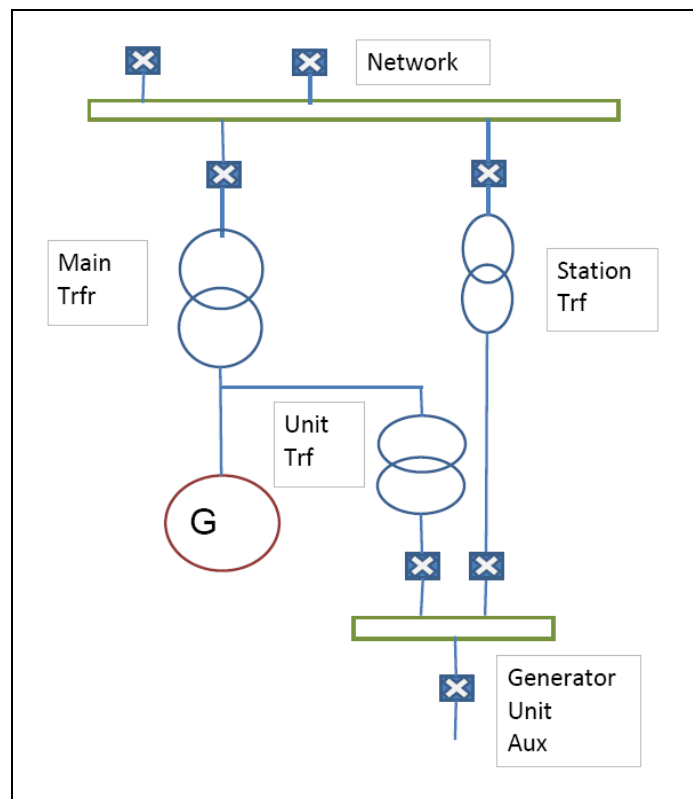

Figure 34: Layout of a thermal power station without a generator circuit breaker

High-speed bus transfer system

The scheme in Figure 34 also requires rapid changeover equipment, to transfer the auxiliary load fed from the station transformer to the generator fed unit transformer. This equipment is also called a high-speed bus transfer (HBT) system [14]. This device evaluates the voltage on the unit board busbar and ensures the quick and timely switching of the various supplies. This device monitors the status of the various controlled circuit breakers and uses three distinctly different algorithms to achieve this changeover [14]. The first option after the change signal is received is a change of supply within the angle window, thus indicating a rapid changeover between the two supplies. This automatic changeover has to occur within a short time, approximately 100 ms, to limit the voltage difference and the current on breaker closure.

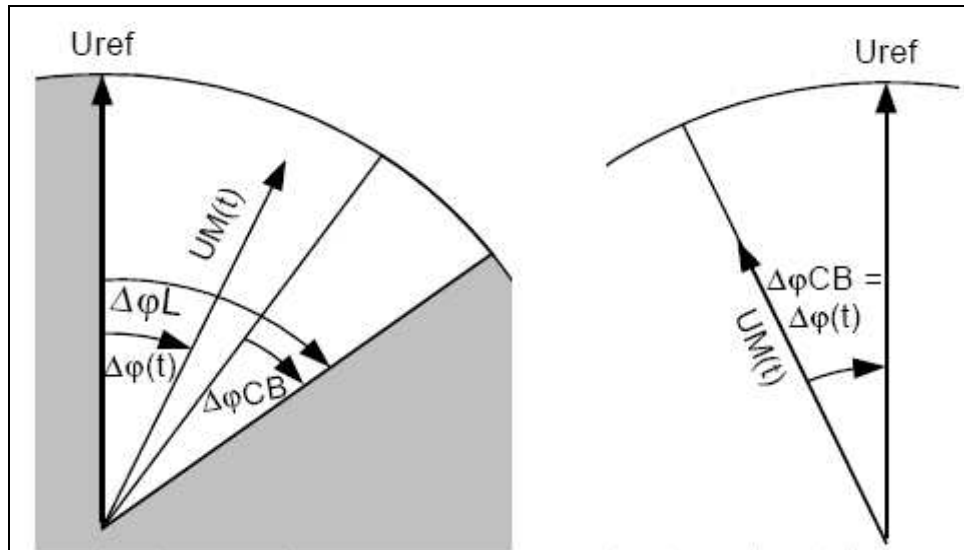

Figure 35: Pointer diagrams of the automatic transfer algorithms used in HBT [14]

Figure 35 depicts the time representation of the switchover characteristic, with:

- U_{ref} Line voltage of the bus
- $U_M(t)$ Line voltage of the connected auxiliaries
- $\Delta\phi(t)$ Phase angle difference
- $\Delta\phi_{CB}$ Angle change while the circuit breaker closes
- $\Delta\phi_L$ Limit angle, after this point the algorithm cannot switch supplies

The change in supply should occur just before the difference in phase angle between U_{ref} and $U_M(t)$ is less than $\Delta\phi_L$. The actual time is $\Delta\phi_L$ minus the $\Delta\phi_{CB}$, as this is used in the software as the blocking signals. The second algorithm, depicted in Figure 35 is similar to the limited time of switching, except that the switching occurs at a complete phase rotation cycle later, but within set phase angle and voltage limits. If these algorithms do not transfer, the remaining option is to wait the residual voltage drops to a low voltage level. This means of transferring the switchboard from one supply to another irrespective of the phase rotation. This can only be achieved below specified voltage limits, usually below 30% of rated voltage.

The HBT is used for the changeover required from the network through the station transformer to the unit transformer. HBT is required in all layouts without a generator circuit breaker. The HBT is also critical for the sustainability of a generating station of

this layout, as the switchover occurs in the start-up or shutdown of the unit (boiler/generator combination).

In Figure 36 the layout of a generating station can be seen with a generator breaker included. The simplistic layout is achieved by eliminating the station transformer and associated high voltage breaker. If a non-unity configuration is followed in the design phase, a station transformer can be inserted as a standby supply for multiple generating units.

HBT equipment can be eliminated and the transformer protection simplified. The generator breaker also ensures that the selectivity of the protection system is optimised. The severity and consequence of generator fed faults is also restricted through a generator circuit breaker

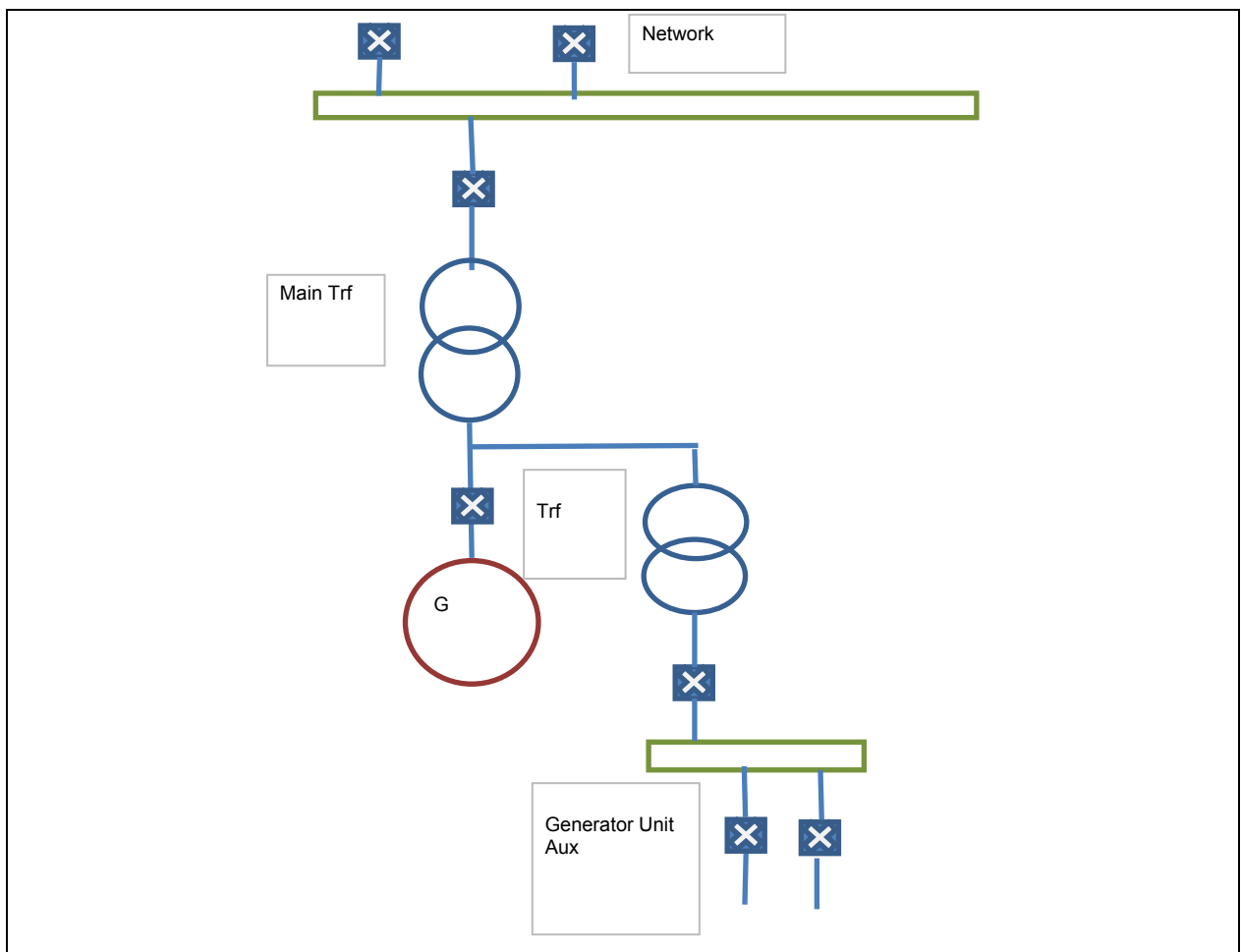

Figure 36: Layout of a generating station with a generator breaker included

Cost implications due to decreased requirements from transformers, the number of high voltage breakers and less control equipment is obvious, but this will be fully discussed in later sections. More than the logical layout of the station, the ease of operation due to the continuous supply through the unit transformer further motivates this layout.

Gas turbines

In Figure 37 a comparison is made between open and combined cycle gas turbines power station layouts with and without generator circuit breakers. It is clear from the figures that through the removal of the station transformer a change in initial cost can be expected and simpler layout of the station archived. One high voltage breaker is also not required.

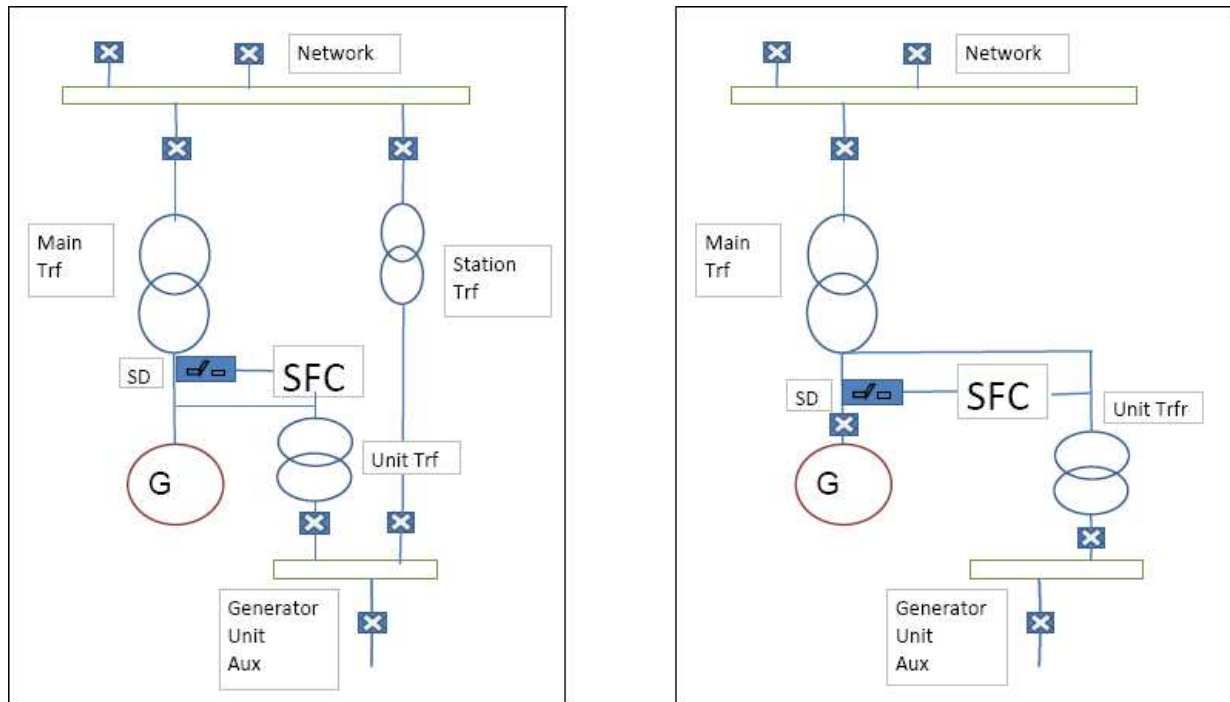

Figure 37: Visual comparison of the difference between Gas turbine power station layouts without and with a generator circuit breaker

As with all gas turbine generators, a static frequency converter is needed to run the generator up to rated speed before synchronization. Another method of achieving this result is to use a pony motor configuration to start the turbine. Full protection can only be achieved by a combination of transformer and generator differential protection (only if generator circuit breaker is included).

The static frequency converter does not need to change with the use of a generator circuit breaker. The power needed for start-up can be directly accessed from the generator transformer and no changeover is required. The benefit of medium voltage synchronization also simplifies operation and limit faults during this operation.

Pump storage power stations

Within the pump storage power station layouts, to change from motoring to generating, the only added component is the phase reversal disconnecter.

Comparison

The benefits of adding a generator circuit breaker are uniform throughout the various layouts. These results have been summarized in Table 6.

To fully consider the benefits of the generator circuit breaker a full reliability and costing analysis is required. This will serve as motivation above and beyond the operational and protection benefits already discussed.

To ensure that a reliable comparative analysis of the various commonly used layouts, a statistical analysis will be used to determine the benefits in reliability, inherent and operational availability. By using the determined values from the survey done on the reliability and availability on power and utility equipment by the IEEE this evaluation will be completed [15]. In short, this study attempted to update the reliability values that were previously obtained in the 1970s [15]. This study was conducted on 204 industrial sites, including offices, prisons, water treatment plants, manufacturing factories, and power stations of various kinds [15]. From this reliability data table all the various components within the various layouts will be used to evaluate the effect of a generator circuit breaker in a generator station.

Table 6: Summary of comparative layout table results

	Equipment Requirements	Protection systems	Overall protect ability of the system	Cost Implications	Complexity of start-up/shutdown	Complexity of operation
Directly Connected Unit (Figure 34)	generator circuit breaker required to clear bus faults.	Generator differential.	Full protection.	Low, due to limitations on size.	Easy.	Easy.
Thermal station layout without generator circuit breaker (Figure 35)	Station transformers and associated breakers are required to power auxiliaries on system start-up and shut-down. These station transformers can be shared between units without generator circuit breakers.	Additional transformer protection needed for station transformer as well as transformer differential protection is used for generator and transformer coverage, and the rapid changeover equipment is needed to change over with generator start-up.	Without any means to separate the transformer and generator the energy stored within this circuit cannot be dissipated, the resultant energy could cause severe damage to the primary winding of the main, unit transformer, and generator.	High due to additional equipment needed within any unit configuration, but some savings can be achieved if equipment such as the station transformer is shared.	High-speed rapid change-over (HBT) is required to disconnect the station transformer and connect the unit transformer as the generator synchronizes on the high voltage side of the main transformer.	Relies heavily on the automatic switchover of the back-up system to the station system, failure of these systems could cause shut-down of generating plant.
Thermal station layout with generator circuit breaker (Figure 37)	Exchange of the station transformer with a unit transformer and the associated high voltage breaker. The needed changeover equipment (HBT), to change from the station to the unit transformer, is not needed as the unit transformer is connected to the network via generator transformer. In certain cases the station transformer is used as a back-up for multiple generating units.	Normal generator differential and transformer differential for the generator transformer and unit transformer is required. Overall protection can be achieved through transformer differential for the entire generating unit. Protection systems is greatly influenced by the installed equipment and the grounding thereof.	All equipment fully protected, with highest selectivity and power station availability.	Lower due to fewer requirements of the transformers within the system and the high voltage breaker that can be eliminated. The additional cost of the generator circuit breaker can be justified through the potential saving in damages to the generator and transformer. Modern generator circuit breaker also include all needed safety equipment reducing civil work with installation.	Easy as the unit transformer is continuously supplied form the network, and the synchronization is completed on the low voltage side.	Simplified operation procedure and logical layout. Only one breaker functioning at synchronization.

	Equipment Requirements	Protection systems	Overall protect ability of the system	Cost Implications	Complexity of start-up/shutdown	Complexity of operation
Gas/Combined Cycle station without generator circuit breaker vs. with generator circuit breaker (Figure 38)	Exchange of the station transformer with the unit transformer, less equipment requirements. Static frequency converter added for start-up of generator. High voltage circuit breaker of the station transformer eliminated.	Full protection can be achieved through transformer, generator and overall differential protection, lesser transformer protection needed as the station transformer is scaled down to the unit transformer ratings.	Energy within the isolated system cannot dissipate normally between the transformer and generator, additional equipment is needed to limit damage within transformer windings.	High voltage station transformer and associated high voltage circuit breaker will be more expensive than the medium voltage unit transformers.	The required static disconnect switch and the static frequency converter need not to be changed through the generator circuit breaker use. With the use of a generator circuit breaker the power to the disconnect can be continuously fed from the network.	Limited changes excluding the low voltage synchronization.
Pumped Storage station with generator circuit breaker vs. Without generator circuit breaker	Possible elimination of the station transformer and only using the unit transformers is an advantage of the generator circuit breaker application.	Overall protection can be applied through bus, differential, transformer, and generator differential systems. No major differences in schemes except the increased selectivity with generator circuit breaker included.	Increased through the selectivity and continues in feed of power from the power system through the generator circuit breaker use.	Decreased installation cost through the incorporated nature of the modern generator circuit breakers. The decreased voltage requirements of the transformers also limit the expenditure initially.	Relative similar except the entire system can be energized before commissioning the generator, thus ensuring the system integrity.	The isolation of the generator through the generator circuit breaker, aids in the simplicity of the system and the number of operations needed at start-up. The synchronization of the system at the low voltage side aids in the operator ability.

4.3 SYSTEM AVAILABILITY AND RELIABILITY

To compare the available time to generate power between various power station layouts, an accurate analysis of the availability and reliability of the various components is required. The IEEE recommended practice for the design of reliable industrial commercial power systems [16] was used to determine comparable values of the components used in generating stations. To fully understand the analysis technique used, some background information is required.

The IEEE Standard 493-1990 [16] summarized 30 years of information gathered by various task groups and organisations. Within these studies, the evaluation criteria includes the failure rate, or failure per component per year, and downtime to repair or replace equipment [16]. In reliability theory, the reliability of equipment is described as the probability of any one piece of equipment failing within a set timeframe. It is common practice to evaluate equipment using an exponential equation, as the frequency of failures will directly affect the reliability of the equipment. The availability of any system can also be determined by the combination of the equipment availabilities. The delay time can be calculated by the mean time to repaired components. This can be portrayed as availability, i.e. as a percentage of generating hours in a year.

To compare the various layouts discussed in the previous sections, the components have to be selected from the available data. The available data will only be used as a reference for relations between the various options to be evaluated, and not to accurately represent the failure rates of any specific power station. The layouts more applicable to thermal power stations will be evaluated, and the gas and pump storage stations are omitted from this section.

The failure rate and mean time to repair per component is used to determine the system failure rate and mean time to restore. For the major components functioning in series, the failure rates directly affects other components, but for components in parallel this is not the case, as the system as a whole will only be affected if both the systems fail at the same time. According to the IEEE Std 493-1990 [16] this amounts to using the added failure rates of equipment in series and for equipment in parallel the product of the failure rates multiplied by the sum of mean time to repair and

divided by the available time will give the failure rate of the combination as depicted in equation 5.

For equipment in series:

$$F_s = \lambda_1 + \lambda_2 \quad (4.1)$$

$$F_s r_s = \lambda_1 r_1 + \lambda_2 r_2 \quad (4.2)$$

$$r_s = \frac{\lambda_1 r_1 + \lambda_2 r_2}{\lambda_1 + \lambda_2} \quad (4.3)$$

And for equipment in parallel:

$$f_p = \frac{\lambda_3 \cdot \lambda_4 (r_3 + r_4)}{8760} \quad (4.4)$$

$$f_p r_p = \frac{\lambda_3 r_3 \cdot \lambda_4 r_4}{8760} \quad (4.5)$$

$$r_p = \frac{r_3 \cdot r_4}{r_3 + r_4} \quad (4.6)$$

Within the equations the following variables have been used:

- F Frequency of failures
- λ failures per year
- r average hours of downtime per failure (Mean time to repair)
- s series
- p parallel

With these equations and the collected data the various thermal layouts can be evaluated. Layouts as depicted in figure 35 and 37 are some of the normal layouts used in thermal power stations. These will be the basic configurations used in the analysis, in various configurations. Firstly, the data used for each component is described in Table 7. This data is derived from the available data on IEEE Standard 493-1990 [19], and applied to the equipment with practical specifications. In IEEE Standard 493-1990 [19] the reliability of any single piece of equipment is defined as: the negative exponential equation of the failure rate per year. This equation is also applied to the total system failure rate to evaluate the various solutions.

Table 7: Summary of the data used from the IEEE Std 493-1990 [16]

Equipment Description	Reliability	Availability	Failure Rate	Mean Time to repair
Generator 12 kV 200 MW	0.844424457	0.999368771	0.1691	32.7
Generator Transformer 250 MVA 12/400 kV	0.971319328	0.997523178	0.0291	745.6
HV Breaker 400 kV	0.927557956	0.998287397	0.0752	199.5
Unit Transformer 20 MVA 12/6.6 kV	0.99432976	0.999065253	0.005686377	1440.000188
Station Transformer 20 MVA 400/6.6 kV	0.99432976	0.999065253	0.005686377	1440.000188
6.6 kV CB	0.990445933	0.999989479	0.0096	9.6
6.6 kV CB	0.990445933	0.999989479	0.0096	9.6
HV Breaker 400 kV	0.927557956	0.998287397	0.0752	199.5
Automatic transfer switch	0.917774618	0.999943753	0.085803433	5.742470956

The availability is defined as the available time as a percentage of one year's available time without the expected time to repair unplanned failures. All the failure rates are derived from the mean value of 30 years worth of data collected from each piece of equipment. The failure rates can thus be used as a guideline to calculate the probability of failure in any one year, and the mean time to repair is the average time to repair any failure associated with the specific piece of equipment. Notice how the power station equipment is generally associated with a low failure rate and a high mean time to repair. This can be attributed to the high requirement of reliability and the excessive cost associated with spare units of this type of equipment.

In addition to the data in Table 7 the data used to evaluate the layouts with generator circuit breakers is depicted in Table 8. This grouping of the data in Table 7 for the specific layout in question has the addition of reliability data for generator circuit breakers as derived from the IEEE recommendations [16]. In Braun [11] the failure rate of the ABB DR air blast generator circuit breaker and the HE SF₆ generator circuit

breaker are quoted as 0.005 and 0.003 respectively. This is 3,5 and 5,8 times lower than the IEEE data. This data depicts the supplier's actual data and based on operation of installed equipment. For this reason, the derived IEEE data will be evaluated in conjunction with the supplier's data to ensure validity of results.

These failure rates will be applied to the calculations described in this section to determine the effect of this single component's reliability on the power station reliability as a whole.

Table 8: Summary of data used to evaluate layouts with generator circuit breakers

Equipment Description	Reliability	Availability	Failure Rate	Mean Time To Repair
Generator 12kV 200 MVA	0.844424457	0.999368771	0.1691	32.7
Generator Transformer 250 MVA 12/400kV	0.971319328	0.997523178	0.0291	745.6
HV Breaker 400 kV	0.927557956	0.998287397	0.0752	199.5
Unit Transformer 20 MVA 12/6.6 kV	0.99432976	0.999065253	0.005686377	1440.000188
6.6 kV CB	0.990445933	0.999989479	0.0096	9.6
Generator Circuit Breaker	0.982553975	0.999978703	0.0176	10.6

Within these analyses three distinct individual variants of the layouts depicted in figures 35 and 36 are evaluated. The normal layouts are compared by evaluating the equipment within the layout to assess the reliability of the layout as a whole. The normal layout seen in Figure 34 is the natural configuration of a thermal power station. In this layout the generator delivers current to the network via a generator transformer, and uses either the station's transformer or the unit transformer to provide power to auxiliary equipment. The variant on this layout with the addition of a generator breaker does not need a station transformer because the unit transformer can, without the generator in service, supply auxiliary equipment from the network. A drawback of totally omitting the station transformer is that a failure of the unit or generator transformer will result in a loss of supply to the auxiliary equipment, which in turn may cause safety related problems. As it is uncommon for generating stations to function as single units, the evaluation of the components are expanded by evaluating several units in parallel. This will result in an increase of the maximum output of the station, but will also ensure that the probability of the station to deliver with one generator at any time increases. As this represents a double cost implication for an initial investment, this opinion was re-evaluated through the evaluation of two parallel units

with only one station transformer. This is then compared to a similar layout with generator breakers included, not excluding the station transformer.

Table 9: Results of failure rate comparison between figure 35 and 37

	Normal Layout (Figure 35) without a generator circuit breaker	Normal Layout (Figure 35) with a generator circuit breaker	Normal Layout (Figure 37) with a generator circuit breaker	
Failure rate of layout	0.464976186	0.482576186	0.306286377	per year
Downtime per failure	159.7	154.3	165.5	Hours
Reliability	0.628150064	0.617191342	0.736175766	p.u.
Availability	0.991519961	0.991498664	0.994212782	p.u.
Downtime per year	74.2	74.5	50.6	Hours per year

In Table 9 the results of the failure rate comparison between the normal thermal power station layout with and without a generator circuit breaker can be seen. The difference between the normal layouts, as per figure 35 and 37 is the reduction of equipment. The difference in equipment amounts to the rapid changeover switch, station transformer and associated high and medium voltage breakers being exchanged by a generator circuit breaker. The limiting of equipment creates a decreased possibility of any single piece of equipment within a power station failing and causing station shutdown. The equipment used in this layout is all assumed to be critical to the initialisation and the correct operation of a generating station. The station transformer is normally only used in the generation capacity on start-up and shutdown of the generating unit, but if the equipment associated with a unit fails it will result in the total mean time to repair at the next planned downtime. There is also risks with failure of the rapid changeover equipment as they form part of the shutdown cycle, and further problems can also occur with the power supplied to the auxiliaries dependant on this equipment. The same principle applies to the layout with the generator breaker included, as all the equipment is required to function fully for the functioning of the generating station. The combination of the results amounts to a generating station without a generator circuit breaker having 0.15 failures more per unit in any one year. In addition, the average down time for repair increases by 15 hours with a similar effect on the average down time per year of the generation station unit. This can be quantified through the 25 hours additional generation time that can result in a possible 50 000 MWh of energy supplied to the network not excluding the

additional revenue. According to Braun [18] a average of 43800 MWh can be added to the continual annual output of a power station, validating the results obtained.

For the second comparison, the units as depicted in Table 9, were evaluated as parallel units and operated as totally independent entities. The reliability data is found in Table 10 and it must be mentioned that the entire system unit is evaluated as a whole unit in parallel with a similar unit.

Table 10: Results of unit configuration of two parallel units with and without generator circuit breakers

	Dual Unit Layouts without a generator circuit breaker's	Dual Unit Layouts with generator circuit breaker's	
Failure rate of layout	0.007886032	0.003545092	per year
Downtime per failure	79.9	82.8	Hours
Reliability	0.992144981	0.996461184	p.u.
Availability	0.999928089	0.999966508	p.u.
Downtime per year	0.63	0.29	Hours per year

Using parallel units to produce power enables the failure rate to decrease dramatically. Although this is true for both the evaluated scenarios, also in this case the less equipment required from the layout with generator circuit breakers means a more reliable method of generating power. The advantages of such fully redundant equipment, although substantial is not feasible as the cost overshadows the benefits. More achievable results can be seen in Table 11 where two units share one station transformer to limit costs. This configuration is compared with a unit-configured station with generator circuit breakers included, but with a single station transformer as a backup system. Although the layout with the generator circuit breaker has more equipment that could possibly fail, the layout results in the station transformer serving as a parallel supply to the unit transformer. This parallel system has a low probability to fail and is the main reason for the greater performance of this system.

Table 11: Results comparison between layout availability for production

	Layout 1	Layout 2	Layout 3	Layout 4	
Failure rate of layout	0.094847063	0.004407044	0.004248616	0.004223539	per year
Downtime per failure	248.6	67.9	70.1	70.5	Hours
Reliability	0.909512022	0.995602653	0.995760397	0.995785367	p.u.
Availability	0.997308232	0.999965825	0.999966003	0.999966031	p.u.
Downtime per year	23.6	0.3	0.3	0.3	Hours per year

Layout 1: Dual equipment for all listed within the normal thermal power station layout, excluding only one station transformer and associated breakers as part of the generating system. This can be seen in Figure 38

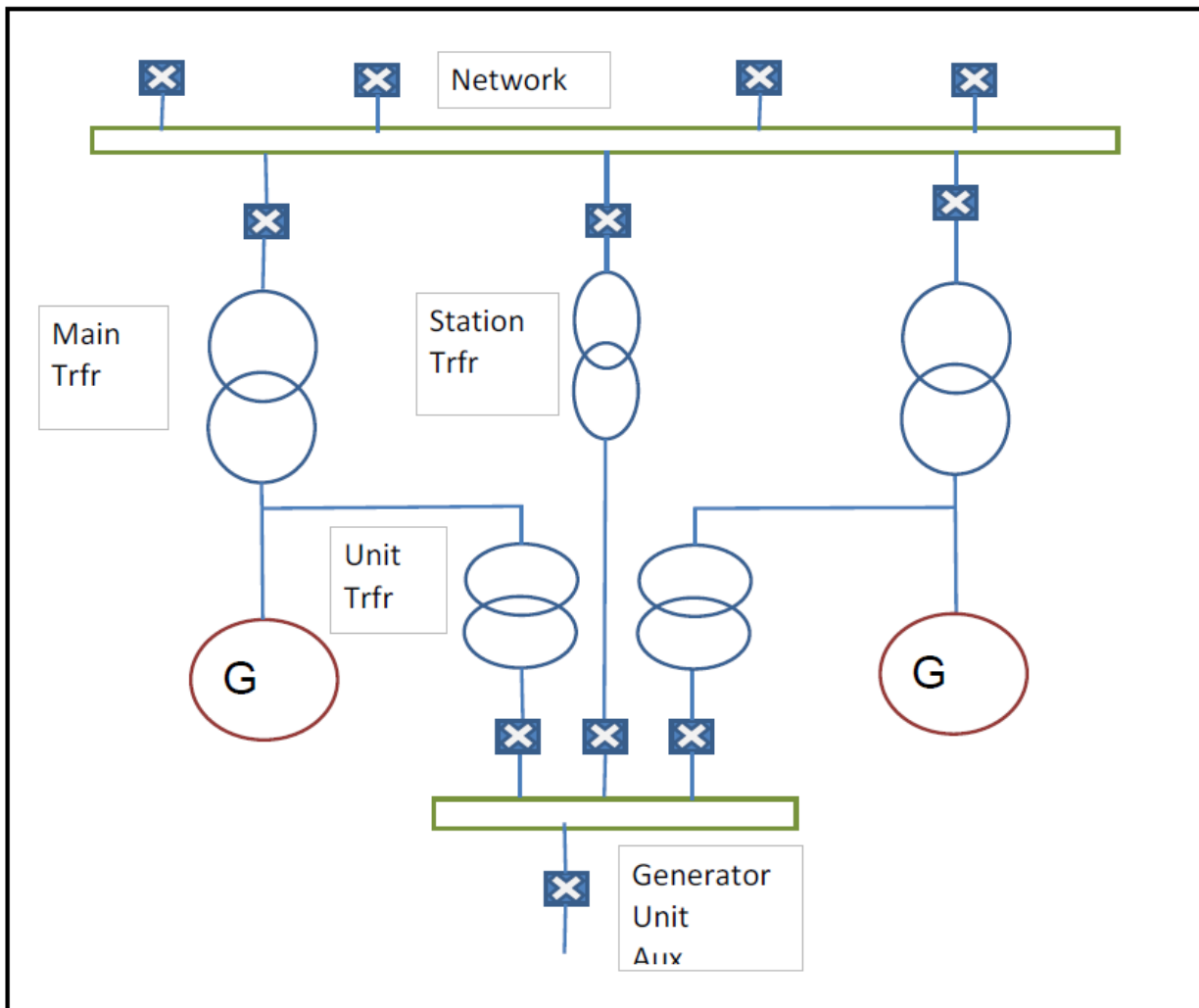

Figure 38: Graphical representation of Layout 1 in table 11

Layout 2: Similar dual equipment as in layout 1 including the generator circuit breaker for each generating unit. A single station transformer is added

as back-up system for the unit transformer system. Thus, the only difference between the first and second layout is the two generator circuit breakers. This layout is graphically depicted in Figure 39

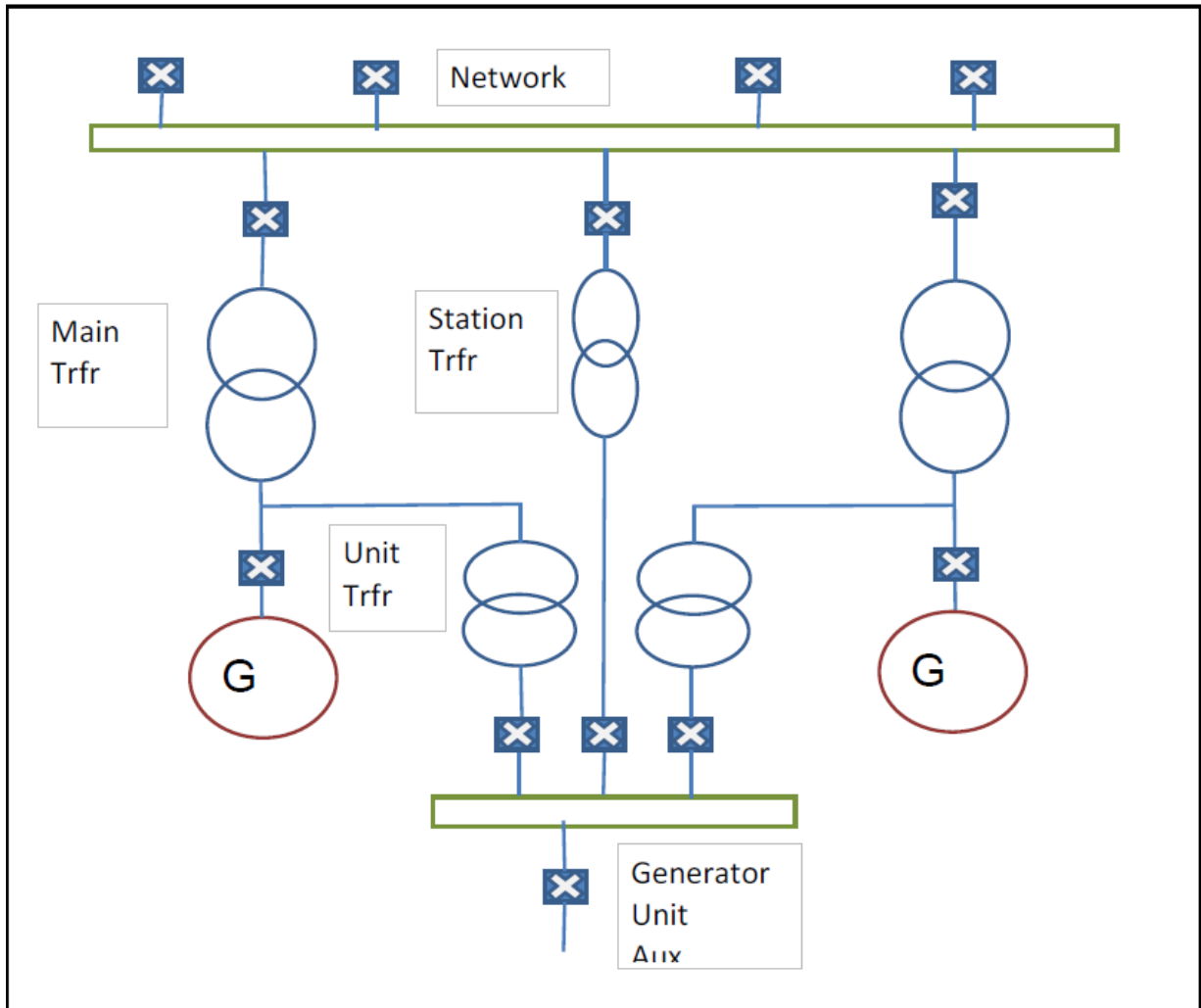

Figure 39: graphical representation of Layout 2, 3 and 4 of table 11

Layout 3: Similar to layout 2 except that the IEEE 493-1990 results for generator circuit breaker are exchanged for the data form ABB DR air-blast generator circuit breaker data.

Layout 4: Similar to layout 2 that except the IEEE 493-1990 results for generator circuit breaker are exchanged for the data form ABB HE SF6 generator circuit breaker data.

From the results it can clearly be seen that the addition of a generator circuit breaker does not in any way degrade the reliability or dramatically affect the repair time of generator station equipment. The addition of a generator breaker and either the decreased importance or the total exclusion of the station transformer and associated equipment relates to a significant increase in reliability and availability of generation systems. This can primarily be attributed to the decreased equipment need for system functioning in any one unit. The possibility of creating redundancy within the system if the standard configuration is followed with the addition of the breakers further increases the system capability. Through the evaluation of actual data from the suppliers [11] and the practical data obtained from the IEEE recommended practice [16] the results obtained from all evaluations with generator circuit breakers included are validated. The effect of the parallel components is dramatic in the improvements in reliability and availability of the plants as a whole. This concept can rarely be achieved or sustained in practise. This is due to the initial cost for installation of additional capacity, and the rapidly growing demands for electricity engulfing most or all redundant capacity. The preventative expansion of power station capacity is also not as feasible as the theory might suggest.

In [18] the researchers found similar results with a more practical results set. They evaluated practical failure data of two Italian generating stations and conceded that for their data set that the inclusion of a generator circuit breaker will improve station availability through the increased reliability of feeding auxiliary equipment directly from the generator and the reduced risk associated with the clearance of generator fed fault current is also noted.

4.4 COST CALCULATIONS

To complete the analysis of various power station layouts the effects of the cost on the choice of implementing generator circuit breakers must be determined. For this analysis the cost of the individual pieces of equipment will be applied to the same scenarios as for the reliability data analysis. For an accurate cost analysis the initial cost and the cost due to unreliability must be evaluated. To ensure that a relative comparison is made the assumptions made must, in most cases, represent practical conditions of generating plants. Such assumptions will be adapted from the data described in the IEEE Std. 493-1990 [16]. From the reliability data tables the failure

rate and the mean time to repair can be gathered. The initial cost of each of the layouts must then serve as a secondary comparable function, but for a reliability cost analysis further assumptions must be made. A plant delay time of 10 hours per start up is assumed, irrespective of the cause of the delay [16]. The IEEE recommends an average revenue of \$16000 per hour, variable cost per hour of \$14 000 and expenses of failures amounting to \$40 000 is applied to resolve this unreliability cost. To approximate a comparable result the following assumptions are made, and this is not based on any data and is for the sole purpose of comparing various layouts. Continuing with the 200 MW generating capacity and assuming a 97% utilization of energy output capability of the generator, it can be assumed that it is possible to deliver 193 MWh to the network in any one hour. This in turn can cost the customer R0.95/kWh to use. Assuming a 30% marginal income on all sales of electricity delivered to the network, this amounts to R55 005/hour lost due to plant delays. Delay time for a power station also reduces some variable expenses due to the station downtime. Thus, if assumed that 25% of cost of generation can be saved after the marginal income is deducted from the cost of a kWh, the saving due to not producing power amounts to R32 086/ hour. Finally, an approximation is required to estimate the cost per failure of a generating plant, and is a fixed value of R110 000 was chosen and a 10-hour start-up time is required per failure. To ensure that the capital investment of a power station can be returned to the investors within 20 years including the interest, a payback amount of 12% is estimated on initial capital investment to meet this requirement.

To evaluate the total cost implications the difference in capital investment cost should be evaluated. The difference between the various thermal power stations is the inclusion of the generator circuit breaker and the exclusion or sharing of the station transformer. Thus, to evaluate the impact the increased availability resulting from the additional investment cost these elements should be listed as can be seen in Table 12. All costs were obtained as budget quotes from various suppliers and conversion rates of R7.50/\$ and R10.50/€ were applied.

Table 12: Summary of budget quotations for power station equipment

	Type	Cost
Generator circuit breaker	12 kV, 100 kA	R3 000 000
HV Breaker	420 kV	R1 375 000
MV Breaker	72 kV	R165 000
Generator Transformer	250 MVA, 12/400 kV	R34 500 000
Unit Transformer	20 MVA, 12/6.6 kV	R4 900 000
Station Transformer	20 MVA, 400/6.6 kV	R12 500 000

From Table 12 it is clear for the scenario in Figure 34 and Figure 36, where the station transformer and the associated breakers are exchanged for a generator breaker that the cost implications required is less for the layout including the generator circuit breaker. The capital cost as well as the costs due to failures must be evaluated. According to IEEE [16] the standard analysis to determine the cost of power stations is performed as indicated in Table 13. Through the time to repair, income lost and variable cost gained by the delay duration, the cost of downtime can be established. With the addition of all the variable expenses incurred and the failure rates, the cost per annum can be obtained. Further evaluation of the capital expenditure per layout can determine the difference in capital expenditure. Through annual escalation of 12% the needed revenue per year can be calculated. The 12% is an assumed cost per year to cover investment charges and associated interest over a 20-year period. The results show that the smaller capital cost of the unit configuration layouts obtained with a generator circuit breaker is the economical option. The two layouts with and without a generator circuit breaker and with a single station transformer, has very similar economical results even though the failure rate and time to repair without generator circuit breakers is higher than the unit including the generator circuit breaker. The evaluation proves that the additional capital spent to obtain the two generator circuit breakers, is similar to the loss in production capacity of the unit without a generator circuit breaker.

To ensure that full picture of the analysis is obtained the following section will summarize the results and findings.

4.5 SUMMARY

During the study it was found that the difference between the two layouts, with and without generator circuit breakers, is the possible omission of the station transformer and the associated high and medium voltage circuit breakers in a layout with a generator circuit breaker. This in turn results in lesser requirements in the capital cost of installation, as well as the elimination of complicated HBT equipment. The inclusion of a generator circuit breaker in a generation station results in improved protection by the separation of the generator and generation transformer after a fault.

Additional benefits include the possibility of synchronising the generator on the low voltage side of the generator transformer, and the auxiliary equipment being continuously powered from the network. A comparison between layouts with and without generator breakers, revealed that unit layouts without circuit breakers has a mean time to repair that is 2.9 hours shorter per equipment failure. On the other hand ,the layout with generator breaker included is more economical as it has less than half the down time due to failure per annum. The major contributing factor to the extended downtime is the additional equipment required. The equipment required in a power station without a generator circuit breaker is necessary to supply power to the auxiliary equipment during start-up and shutdown. This equipment contributes to R14 million in additional capital cost. For similar layouts, excluding the generator circuit breaker, the study concludes that the increase in capital cost due to the generator circuit breaker use is countered by the increase in availability.

The financial elements result in the unit configuration without a station transformer and including a generator circuit breaker being the most economical option. This is due to the higher availability following the inclusion of the generator circuit breaker and the decreased capital input cost due to equipment requirements.

Table 13: Summary of costing data for all evaluated solutions

Descriptions	Dual Thermal layout without generator circuit breaker	Dual Thermal layout with generator circuit breaker	Dual Thermal layout without generator circuit breaker with single station transformer	Dual Thermal layout with generator circuit breaker and single station transformer
R = average time to repair failure	79.88	82.75	248.61	67.93
S = plant start up time per failure	10	10	10	10
R + S	89.88	92.75	258.61	77.93
Gp - Xp= income lost per hour of plant downtime – variable expenses saved	R 22 918.72	R 22 918.72	R 22 918.72	R 22 918.72
(R+S)(Gp-Xp)	R 2 059 934.55	R 2 125 711.28	R 5 927 010.18	R 1 786 055.85
Xi = Variable expenses per failure	R 110 000.00	R 110 000.00	R 110 000.00	R 110 000.00
Sub Total	R 2 169 934.55	R 2 235 711.28	R 6 037 010.18	R 1 896 055.85
Failure rate per year	0.007886032	0.003545092	0.094847063	0.004407044
X = Annual Sub total cost	R 17 112.17	R 7 925.80	R 572 592.68	R 8 356.00
F = Capital investment excluding generator	R 109 960 000.00	R 87 880 000.00	R 95 920 000.00	R 101 920 000.00
CF = Fixed investment charges (12%)	R 13 195 200.00	R 10 545 600.00	R 11 510 400.00	R 12 230 400.00
G = X + CF Minimum requirement per year	R 13 212 312.17	R 10 553 525.80	R 12 082 992.68	R 12 238 756.00

Chapter 5: Conclusion

In this study various aspects of circuit breaker technology was researched and explained, to assist in the evaluation of the use of generator circuit breakers in power stations. To fully understand the functionality of the generator circuit breaker the operation, development and constraints of the circuit breaker were investigated. The function of the circuit breaker in an electrical circuit cannot be excluded from the protection system that continually evaluates the conditions and signals the breaker requires to operate. Although the general information on circuit breakers is necessary, the characteristics of the generator circuit breaker have to be explored to exhibit the complexity of this device. To answer the question of using a generator circuit breaker in a modern power station, the effect, extent and the cost implications of this modification was evaluated. To ensure realistic results practically implemented layouts were used. The evaluation concentrated on the combination of the reliability of individual pieces of equipment and the effect of including and excluding a generator circuit breaker on the reliability, availability and mean time to repair of the power station. This data was used to evaluate the running cost associated with each layout. The layout capital cost was also determined using the current prices for the individual equipment components. The total financial analysis would determine which of the layouts should be preferred as well as the feasibility of using a generator circuit breaker.

From this approach, the data required to complete the evaluation was compiled. The evaluated data showed the most practical interruption technology to use was a generator circuit breaker using vacuum up to 100 MVA, SF₆ for units producing fault currents up to 200 kA and for the extreme cases air-blast circuit breakers can be used. None of these units operate without limitation or some form of complexity e.g. air circuit breakers with self-pressurization operation mechanisms

still requires high-energy intensive switching assistance and in addition are costly, bulky and maintenance intensive.

Vacuum technology can easily be incorporated into a generator circuit breaker, but has restrictions on interrupting capacity. The commonly used generator circuit breaker uses SF₆ as the interruption medium of choice. With the development of self-pressurized mechanisms and the exceptional dielectric capacity of SF₆ limiting contact travel, this energy efficient operation aids in the performance of this medium in this application. Some operational conditions requires a generator circuit breaker to include the synchronising of the generator unit with the network, which can lead to switching in during out-of-phase conditions.

The use of the generator circuit breaker within the power system creates the possibility of supplying the auxiliary equipment directly from the network, ensuring the functionality of the systems while switching occurs. It also ensures that the generator fed short circuit currents are interrupted with the shortest possible delay to prevent consequential damage to the equipment. This is achieved by isolating the generator and the generating transformer with the use of differential protection to limit the extent of the damage in the event of failure. The general requirements of a generator circuit breaker is to function at and interrupt extremely high currents. Therefore, some difficulty can occur with the switching of low magnitude current. To complicate the situation even further the switching of these low amplitude currents such as transformer inrush currents or line charging currents will result in low current switching with high X/R ratios. This complicates the operation and the control of this breaker. The interruption of high fault currents does not only result in stresses of an electrical nature and relies on the dynamics of the arc to complete the interruption. The interruption of high current faults results in a pressure increase and the overpressure relief valves are critical for the performance of the breaker. The contact material and the methods of preserving and optimising were investigated and explained.

Advances in this technology dramatically aided in the development of modern generator circuit breakers.

The primary layouts considered in this text were a generator feeding into the generating transformer and through the high voltage disconnect and circuit breaker into the network. The auxiliary supply, fed from the unit transformer is fed from the low voltage side of the generator transformer, and the power required for these systems while the generator is out-of-service is fed directly from the network through the station transformer. The alternative configuration is that the generator circuit breaker is included, and with this the station transformer is either used as a backup of the network fed unit transformer, or omitted due to cost implications. The availability analysis has shown that the use of the generator circuit breaker increased the availability of the power station, due to the elimination of equipment or their roll changes to a backup function. One consequential effect of the use of the generator circuit breaker is an increase in the mean time to repair equipment, but if considered with the additional availability this has limited effects.

The cost analysis is based on the assumption of operational fixed and variable cost of a power producer, and the effect that the calculated availability should have on these costs. This, in addition to the capital cost requirements, of the various layouts resulted in the conclusion that the use of a generation circuit breaker can result in more income due to the cost saving. This is an effect of the decreased capital cost required to implement the generator circuit breaker and the omission of the station transformer. Furthermore, the exclusion of the station transformer, the associated high and medium voltage circuit breakers, and HBT equipment save cost. Less equipment results in a higher availability of the system, limited capital investment due to the implementation, and the ease associated with the protection of the system, that all support the use of a generator circuit breaker in a power station as the most feasible option.

References

- [1] Definition for power switchgear, ANSI/IEEE C37.100-1981, New York, USA, 1981, pp 16.
- [2] Bharat Heavy Electricals, Handbook of Switchgears, 1st ed., New York, McGraw-Hill, 2007, pp. 1-39, pp 47-99, pp 211-219, pp 271-278.
- [3] Garzon, R.D., HV Circuit Breakers: Design and applications, Square D Co., Marcel Dekker, 1996, pp 129-222.
- [4] T. Kelsey and H. C. Petty, "The Air-Blast Circuit Breaker", Philosophical Transactions of the Royal Society of London. Series A, Mathematical and Physical Sciences, Vol. 275, No. 1248, The Royal Society, 30 Aug., 1973, pp. 131-138.
- [5] Picot, P., "Vacuum Switching", Cahier Technique Schneider Electric, No. 198, France, March 2000. pp 5 – 30.
- [6] Reece, M.P., "A Review of the Development of the Vacuum Interrupter", Philosophical Transactions of the Royal Society of London Series A, Mathematical and Physical Sciences, Vol. 275, No. 1248, The Royal Society, 30 Aug. 1973, pp. 121-129.
- [7] ANON. (2008). Comparison between Vacuum and SF6 circuit breaker for medium voltage application. <http://www.scribd.com/doc/6671367/Comparison-between-vacuum-and-sf6-circuit-breakers-for-medium-voltage-application>. Accessed 10 May 2009.
- [8] ABB Switchgear Manual - A Pocket Book, 10th Edition, ABB, Berlin, 2001. pp 409 – 426.

- [9] Zehnder, L., Kiefer, J., Braun, D. and Schoenermann, T., "SF₆ generator circuit breaker system for short-circuit currents up to 200 kA", Technologies for the utility industry, 2002, ABB review 3, pp 34 – 40.
- [10] Canay, M., Braun, D. and Koppl, G.S., "Delayed current zeros due to out of phase synchronizing", IEEE Transactions on Energy Conversion, New York, vol. 13, No. 2, 1998, pp 124-132.
- [11] Braun, D. and Guerig, A., "Life Management for Generator Circuit Breakers", ABB High Voltage Technologies Ltd, 1994, Switzerland, pp .
- [12] Lord, T., "SF₆ Gas Management to best practice", Lord Consulting, Power Industry Update, New Zealand, February 2008. pp 1 – 9.
- [13] Network Protection and Automation Guide, , 4th Ed., ALSTOM, France, 2005, pp 280-315.
- [14] ANON. (a.d.). ABB Switzerland Ltd, Synchrotact HBT, www.abb.com/synchrotact, accessed 2 September 2009, pp 1-14.
- [15] Hale, P.S. and Arno, R.G., "Survey of reliability and availability information for power distribution, power generation, and HVAC components for commercial, industrial, and utility installations", IEEE Industrial and commercial power systems, Florida, 2005, pp 659-684.
- [16] IEEE Standards Board, IEEE recommended practice for the design of reliable power systems, IEEE Std 493-1990, pp 7-85, pp 213-300.
- [17] Chanda, K., Parthasarathi, R. and Holla, S., "Estimation of short circuit capability of generator circuit breaker for a generator fed fault", Transmission and distribution conference and exposition, Latin America, 2008, pp 1 – 4.

[18] Braun, D., Granata, F., Delfanti, M., Palazzo, M. and Caletti, M., "Reliability and economic analysis of different power stations layouts", IEEE Bologna PowerTech conference, Italy, 2003. pp 1- 8

[19] IEEE Standards Board, IEEE Standard for AC high-voltage generator circuit breakers rated on a symmetrical current basis, IEEE Std C37.013-1997, pp 57.