

## RESULTS

---

Results from case studies

---

## 4 RESULTS

### 4.1 Introduction

The compressed air saving strategy developed was implemented at several deep-level gold and platinum mines in South Africa. Confidentiality agreements with these mining companies prevent the use of their real names. The Mine 1, Mine 2 naming convention was used in previous chapters for mines where previous energy savings projects were done without using an integrated approach.

This naming convention will not be used for the case studies discussed in this chapter to avoid confusion between the case studies where the new strategy was implemented and previous projects investigated for the literature study. The mines where the new integrated approach was implemented will be referred to as Mine A, Mine B, Mine C and Mine D respectively. The new integrated approach was followed to implement energy saving projects on twenty-two mine compressed air systems. Four typical case studies will be discussed in detail. A summary of the results for all twenty-two projects will then be provided.

### 4.2 Mine A: Multiple shafts, single compressor house, universal compressor size

The compressed air system at Mine A consists of five similar centrifugal compressors. The designed flow capacity of each of the compressors is 26 580 m<sup>3</sup>/h. Each compressor is powered by a 2 600 kW induction motor. A simplified layout of the compressed air system at Mine A is shown in Figure 52. The compressors were already equipped with inlet control valves to throttle the compressed air supply of the compressor.

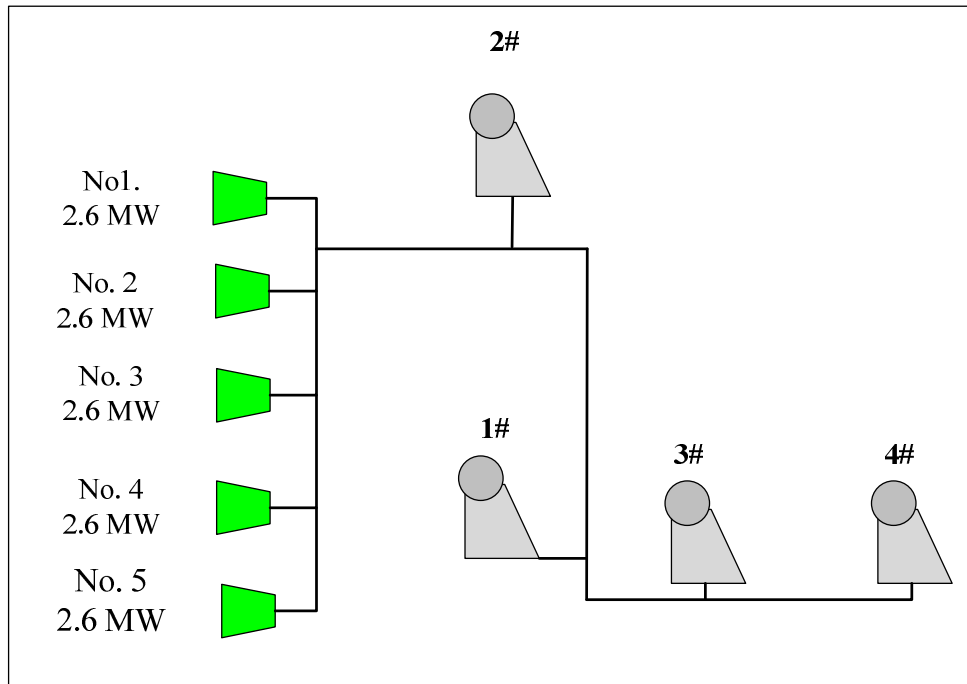

*Figure 52 – Simplified surface compressed air layout for Mine A*

Blow-off valves were also already installed to prevent compressor surge. The control valves together with auxiliary equipment were controlled with an automatic control system dedicated to each compressor prior to the implementation of the new project. The controllers were supplied by the original equipment manufacturer (OEM).

A centralised compressor control system, supplied by the OEM, was used to signal stop-and-start commands to the individual compressor controllers according to compressed air demand. Predefined set points and control schedules were programmed into the centralised compressor control system to stop and start the compressors. The first step towards compressor optimisation, according to the integrated approach, is automatic compressor control. The compressors at Mine A were already automatically controlled by an OEM system.

The second step towards improving the efficiency of a compressed air system is to control the compressed air distribution on surface. Surface control valves were not installed at Mine A. Underground control valves were, however, installed as part of a previous project at the two main production shafts. The installation was done as an attempt to reduce compressed air consumption during non-drilling periods. The control valves are controlled from a control room situated on surface.

The control valves could not be operated according to an automated schedule because the production crews did not always leave the working levels at the same time. The control room operator was therefore required to manually operate the control valves when the production crews did not require compressed air anymore. The control valves were not fully functional at the time of the investigations. The mine was nonetheless in the process of fixing the control valve system. The mine was also in the process of installing surface control valves at the other shafts to control compressed air demand.

Analysis of the power consumption and system pressures was done to determine whether the compressor control system operated efficiently. The average baseline power consumption of the compressors is shown in Figure 53. The pressure at the compressors is also indicated on the graph. Analysis of the graph indicates that the system pressure was lower during peak compressed air demand periods than during other periods. The peak compressed air demand occurs during the drilling shift. The baseline pressure during peak drilling times was 546 kPa on average. This was 51 kPa lower than average values during non-peak drilling times.

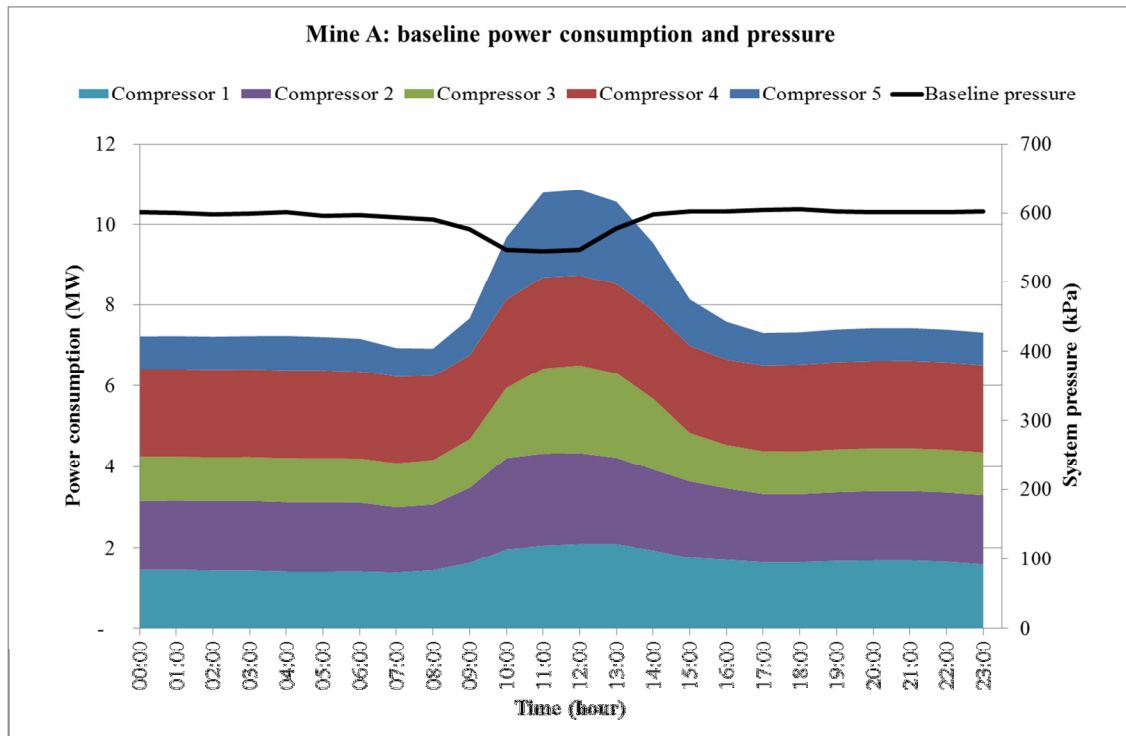

Figure 53 – Baseline power consumption and pressure for Mine A

The literature review revealed that high system pressures during non-peak drilling times were the result of inadequate compressor control during these low demand periods. Historic data for the control valves was not available due to problems with the SCADA logging system. The personnel responsible for the surface compressed air system indicated that a pressure of 500 kPa at the compressors was sufficient for all pneumatic equipment. The system was thus always overpressurised.

The power profile shown in Figure 53 indicates that the compressor power did not decrease as much as expected during the non-drilling periods. The first step towards compressor power reduction was to ensure that the compressors were adequately controlled. Historic compressor power consumption data was compared to the inlet valve openings for a typical working day to investigate the reason for the high pressure.

An example of the relationship between the inlet valve opening of the compressor and the power consumption of a compressor at Mine A is shown in Figure 54. The average power consumption with a 100% valve opening is 2 300 kW. It can be observed from the graph that the power consumption reduced to 1 800 kW at an inlet valve opening of 40%. This compressor was not operated below a 35% valve opening to prevent surge.

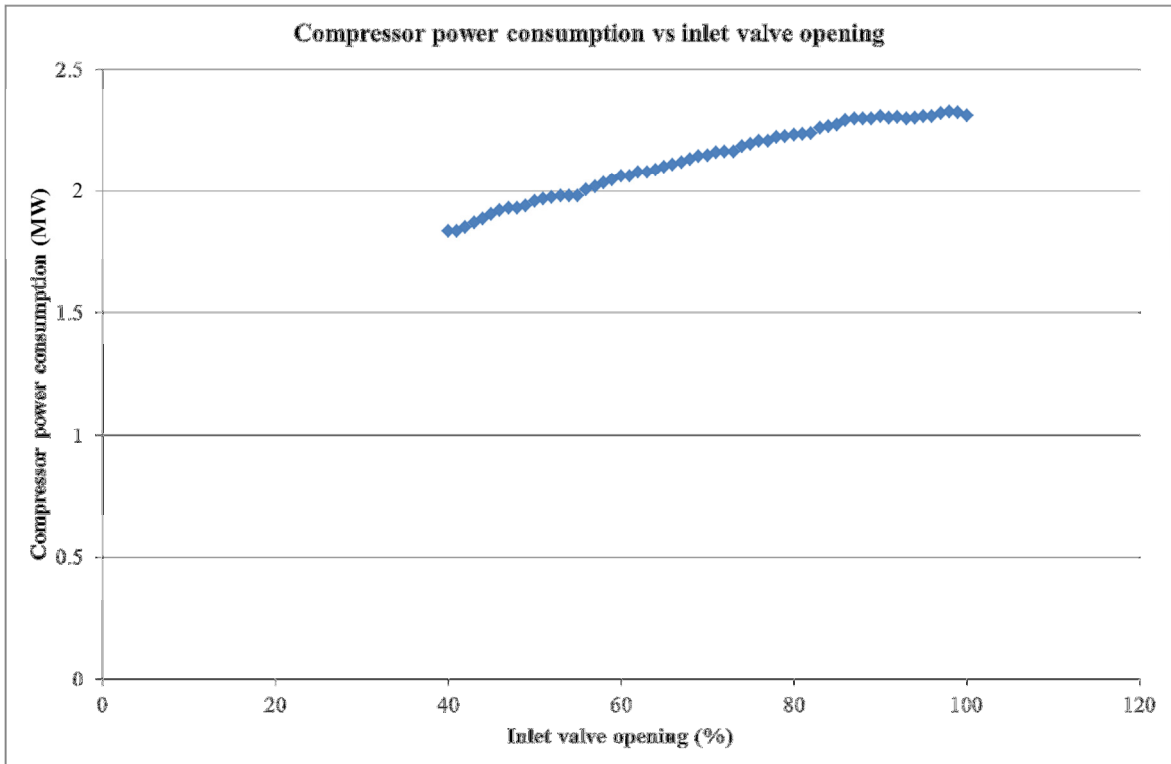

Figure 54 – Comparison between inlet valve opening and compressor power consumption for Mine A

It is more efficient to operate one compressor at maximum load than it is to operate two compressors at minimum load. As an example, two compressors at Mine A operating at inlet valve openings of less than 38% consumed between 3 200 kW and 3 500 kW. The maximum combined flow supplied at these conditions was 23 000 m<sup>3</sup>/h. This was less than the designed capacity of 26 850 m<sup>3</sup>/h for one compressor. The operation of one compressor will not consume more than 2 300 kW. A saving of at least 900 kW could therefore be achieved if only one compressor was operated at full load.

Detailed data analysis and simulations could be used to determine the savings possible by limiting the number of running compressors, though this would be a time-consuming task. An easier approach to identify the savings due to a reduced number of compressors was followed. Historic data was used to calculate the average number of compressors in operation for every hour of the day. This was compared to the average inlet valve openings of all the compressors.

This comparison revealed that too many compressors were used for the biggest part of the day. It was noted that on average at least one too many compressor was operated for twenty hours per day. The baseline pressure was also above the required pressure. Additional savings could therefore be achieved by reducing the pressure set point of the system.

The simulated revised compressor power profile is compared to the baseline power profile in Figure 55. A simulated saving of 2.72 MW could be achieved by using fewer compressors at maximum load instead of multiple compressors operating at low load conditions. These savings included the effect of the reduced system pressure of 520 kPa.

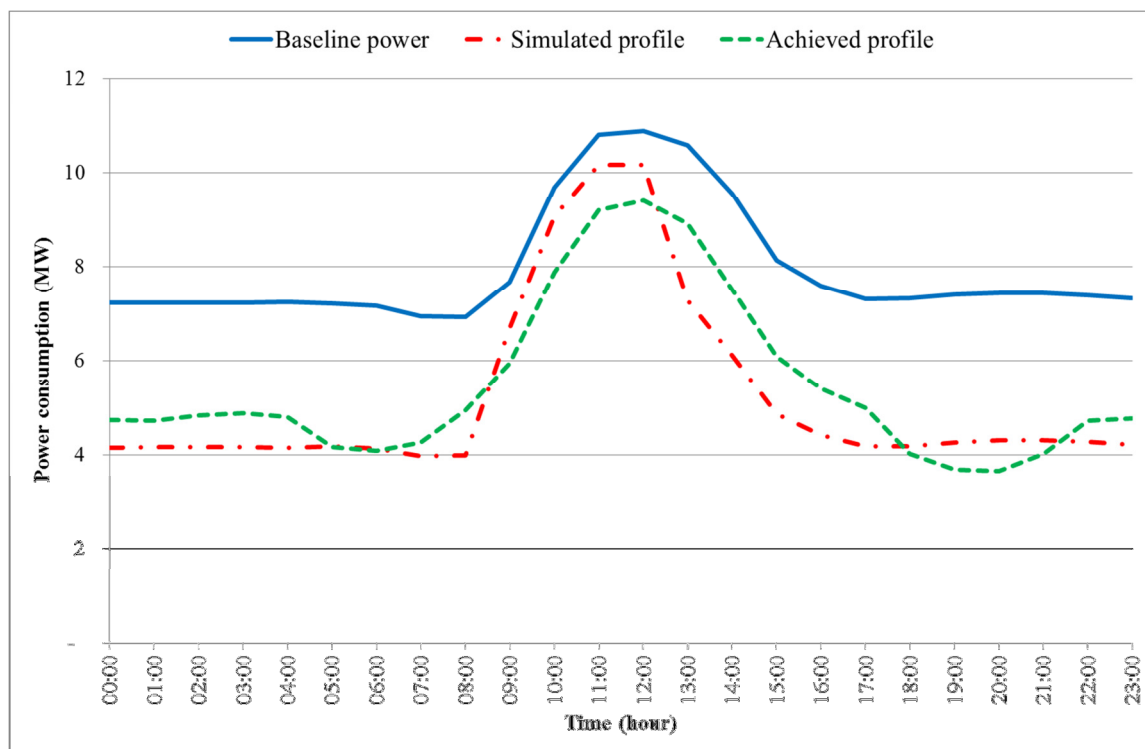

Figure 55 – Comparison between baseline and simulated profiles for Mine A

It was not possible to change the control philosophy of the OEM compressor control system to use fewer compressors at higher loads. It was opted to install a new control system using Programmable Logic Controllers (PLC) combined with Real-time Energy Management System (REMS). The increased functionality of the new control system made it possible to reduce the number of compressors in operation when the compressors were not running at full capacity.

The new compressor control philosophy involved a direct link between the instantaneous compressor load and the system pressure. The detailed compressor control philosophy will not be discussed because the intellectual property belongs to the sponsors of this study.

The new control philosophy was implemented and was tested after which the performance was monitored over a period of three months. The compressor power profile after the implementation of the new system is shown in Figure 56. Observations of the figure indicate additional reduced demand during the blasting periods: 17:00 to 22:00. Actual data regarding the operation of the underground control valves was not available. It was, however, expected that control valves contributed to the savings achieved during the blasting periods.

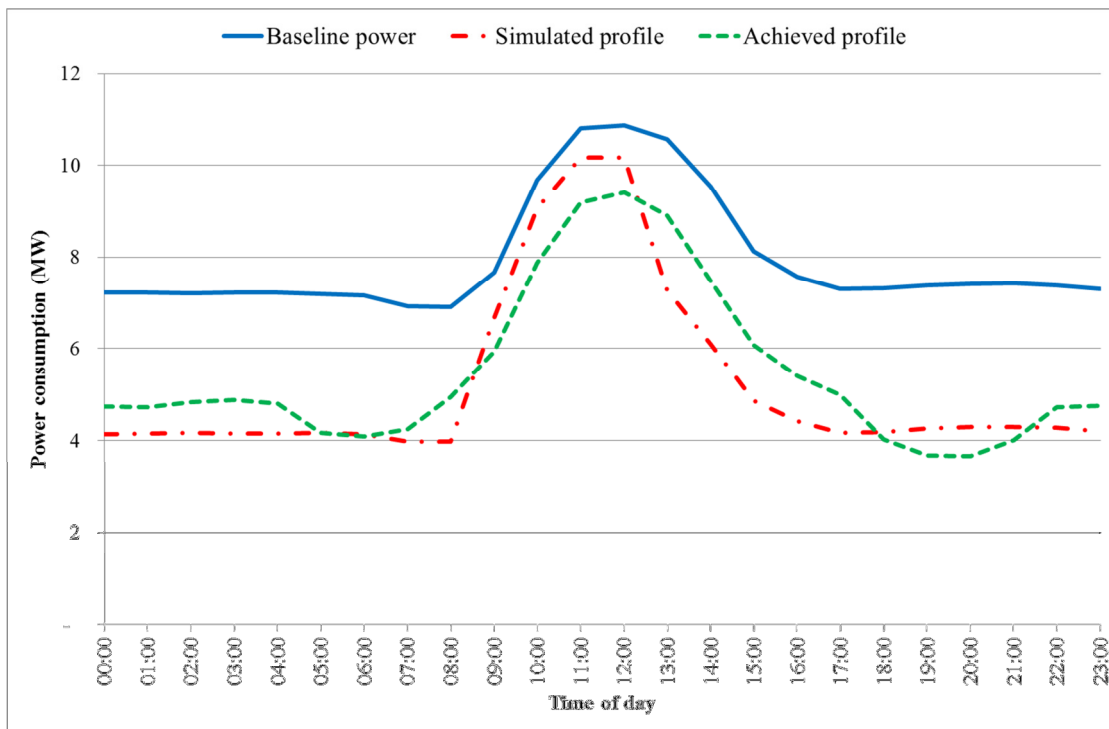

Figure 56 – Comparison between simulated and actual results at Mine A

Initial investigations revealed that the system pressure was higher than actual requirements with the initial OEM control system. The control philosophy of the OEM control system was to ensure that at least the set-point pressure was reached. Only pressures well above 600 kPa resulted in automatic compressor shutdown. The new compressor control system narrowed the control range to ensure reduced compressor power consumption. A comparison between the baseline pressure and the pressure with the new control system is shown in Figure 57.

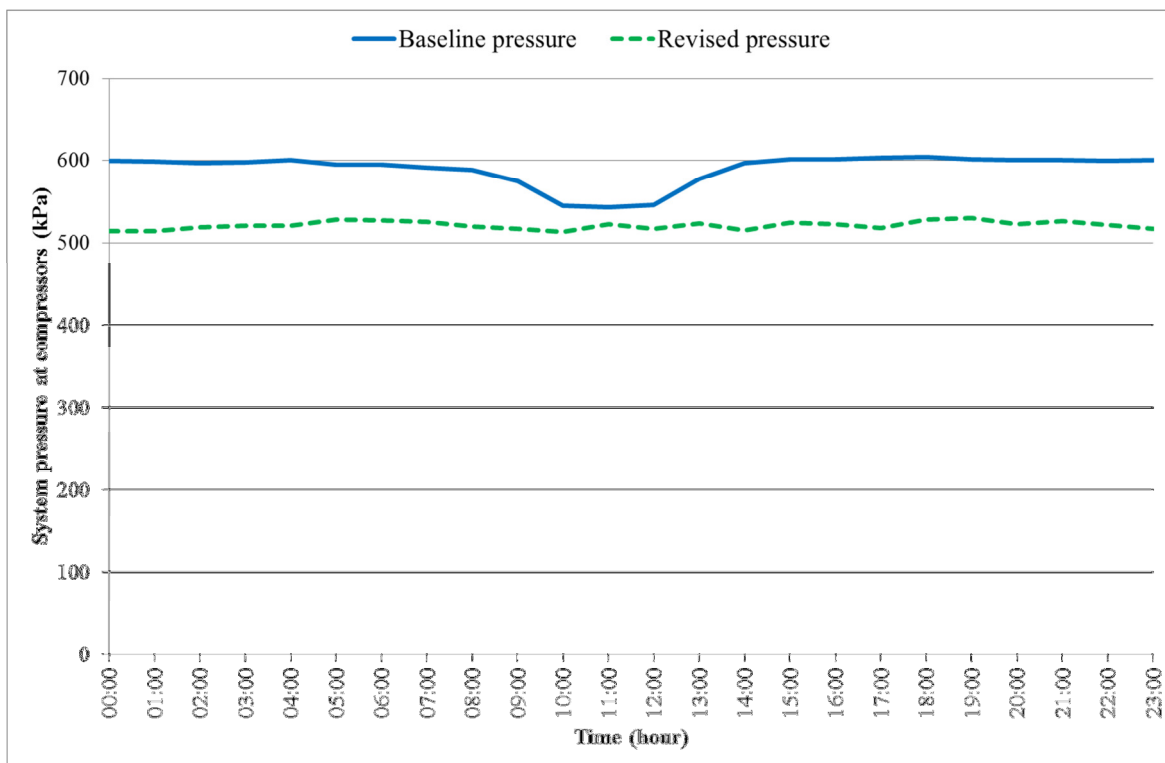

Figure 57 – Comparison between baseline pressure and the pressure after project completion at Mine A

The actual saving achieved over a 24-hour day was 2.45 MW that is within 10% of the predicted saving of 2.72 MW. Most mines, including Mine A, are invoiced using the Eskom Megaflex tariff structure. The expected electricity cost savings for all projects mentioned in this study will be calculated by using the Megaflex rates applicable from 1 April 2012 to 31 March 2013 [65]. A saving of 2.45 MW should correspond to a yearly cost saving of R7.2 million.

It is possible that detailed simulation software such as KYPipe could be used to predict savings with improved accuracy. However, these simulation models require very detailed information. Gathering detailed system information such as exact pipe lengths, pipe friction components, compressor performance maps, and so forth for mine compressed air systems would be a painstaking task.

The integrated approach resulted in estimated savings that was within 10% of the actual savings achieved. The next step of the integrated approach would be to start with the replacement of pneumatic equipment to lower the system pressure even further. The discussions in Chapter 2 made it clear that this is an expensive approach and it is unlikely that the payback periods would make the project feasible.

### 4.3 Mine B: Multiple shafts and compressor houses

The compressed air system at Mine B consists of five compressors. Compressed air is supplied to three shafts by means of a surface pipe network. A simplified layout of the surface compressed air system is shown in Figure 58.

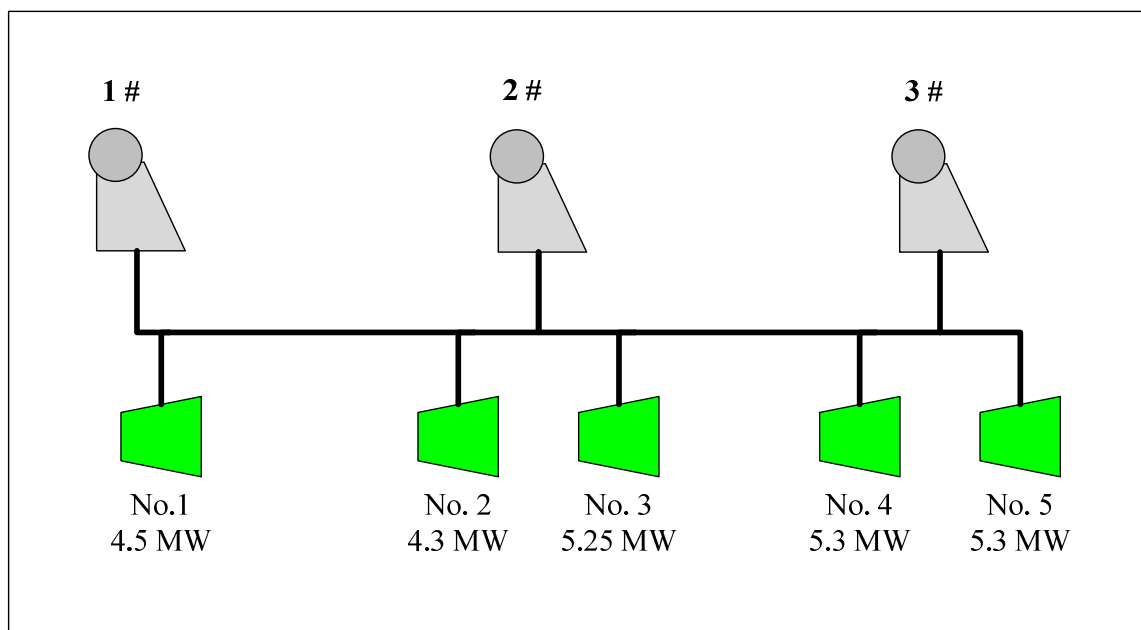

Figure 58 – Simplified surface compressed air system layout of Mine B

A simplified compressed air model was developed for the compressed air system at Mine B by using data recorded during 2009. The data consisted of system pressure and compressor power consumption. The average weekday 24-hour profile for this data set is shown in Figure 59. The first step for improving the efficiency of mine compressor air systems according to the integrated approach requires that the compressed air supply must meet the demand. It was apparent from the pressure baseline that there was an oversupply of compressed air during the non-drilling periods.

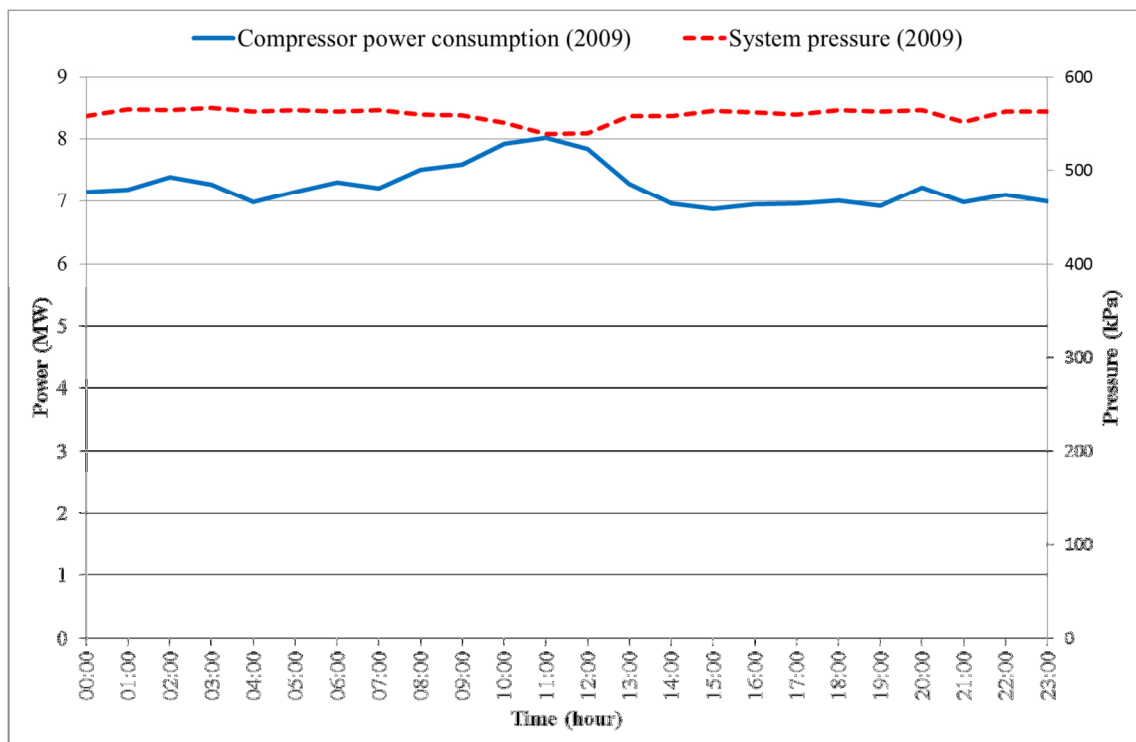

Figure 59 – Compressor power consumption and system pressure for April 2009 and May 2009 at Mine B

Inlet control valves were already installed on all of the compressors at Mine B. The set points of the capacity control systems were, however, fixed at 600 kPa at the time of the investigation. It is clear from Figure 59 that the set point was not a realistic value because the set point was never reached. The operating schedules and pressure requirements of the most important pneumatic equipment are summarised in Table 7.

## Results

---

*Table 7 – List of key pneumatic equipment used at Mine B*

<b>Equipment</b>	<b>Approximate Quantity</b>	<b>Pressure required</b>
Loaders	15	450 kPa
Rock drill	300	450 kPa
Loading box	80	450 kPa
Refuge bay	70	250 kPa
Agitation	-	400 kPa

The loaders, rock drills and loading boxes had the highest pressure requirements. The high-pressure equipment was typically only operated from 07:00 to 15:00 on weekdays. On the other hand, refuge bays and agitation had to be constantly supplied with compressed air. The system pressure at the point of use had to be at least 450 kPa.

The working areas in typical deep-level mines can be as much as four to six kilometres from the point of supply on surface. This distance will increase even further if the operating compressors are not situated at the shaft. A pressure loss is therefore expected from the compressors to the point of use due to line friction. A pressure increase can, however, also be expected at the deep mining levels as a result of autocompression.

It would be difficult to accurately calculate the pressure drop due to the many unknown factors such as exact pipe lengths, pipe diameters, pipe friction as well as the number of productive and non-productive leaks. The differences between the compressor set points and the actual system pressure were discussed with the employees at the mine. It was suggested to the mining personnel that the system pressure set points be lowered. Mine personnel said that they would be satisfied with a compressor delivery pressure of 550 kPa for the drilling period and 490 kPa during other periods. They know from experience that these pressures would be sufficient to counter the pressure drop due to line friction.

The simulation model was used to predict the energy savings if the schedule shown in Table 8 is applied.

*Table 8 – New compressor delivery pressure set-point schedule*

<b>Pressure schedule</b>	<b>System pressure (kPa)</b>
Peak drilling shift (07:00–15:00)	550
Off-peak shifts (15:00-07:00)	490

The simplified simulation model predicted a saving of 0.9 MW based on the revised pressure schedule. More recent compressor power consumption data, logged during 2010, was also available. System pressure data was, however, not available for the same period. Yet, the power consumption profile for the 2010 data was very similar to the profile of the 2009 data, with the exception that the 2010 data was on average higher than the 2009 data. It was assumed that the system pressures for the 2009 period would be similar to the pressure profile for the 2010 data. The effect of a proposed pressure schedule was simulated with the 2010 power consumption profile.

The simulated results predicted that the saving based on the 2010 profile would be 0.98 MW. This was only slightly more than the predicted saving of 0.9 MW for the 2009 data. The predicted savings were verified by performing a manual test over a 48-hour period. Compressor set points were manually changed according to the schedule in Table 8 to confirm that the reduced set points would ensure adequate compressed air supply at the point of use. No low-pressure complaints were received with the revised pressure schedule. An average saving of 0.97 MW was achieved during the 48-hour test.

The simulation and the tests confirmed that an average saving of at least 0.9 MW could be obtained by following the suggested pressure profile shown in Table 8. A project that involved the upgrade of the compressor control systems allowing the automatic compressor scheduling and control was implemented at Mine B. The performance of the project was assessed over a three-month period after the implementation of the project.

## Results

A comparison between the revised compressor power consumption and the baseline compressor power consumption is shown in Figure 60. An average saving of 1.7 MW was achieved when compared to the baseline profile that was calculated with the 2010 data. Most mines, including Mine B are billed according to the Eskom Megaflex rates. The expected electricity cost savings was calculated by using the Eskom Megaflex tariff structure. The reduced energy consumption related to an annual electricity cost saving of R4.7 million (2012/2013 tariffs). The 0.7 MW additional saving was most likely due to leak repairs that were done by the mine after the baseline was established.

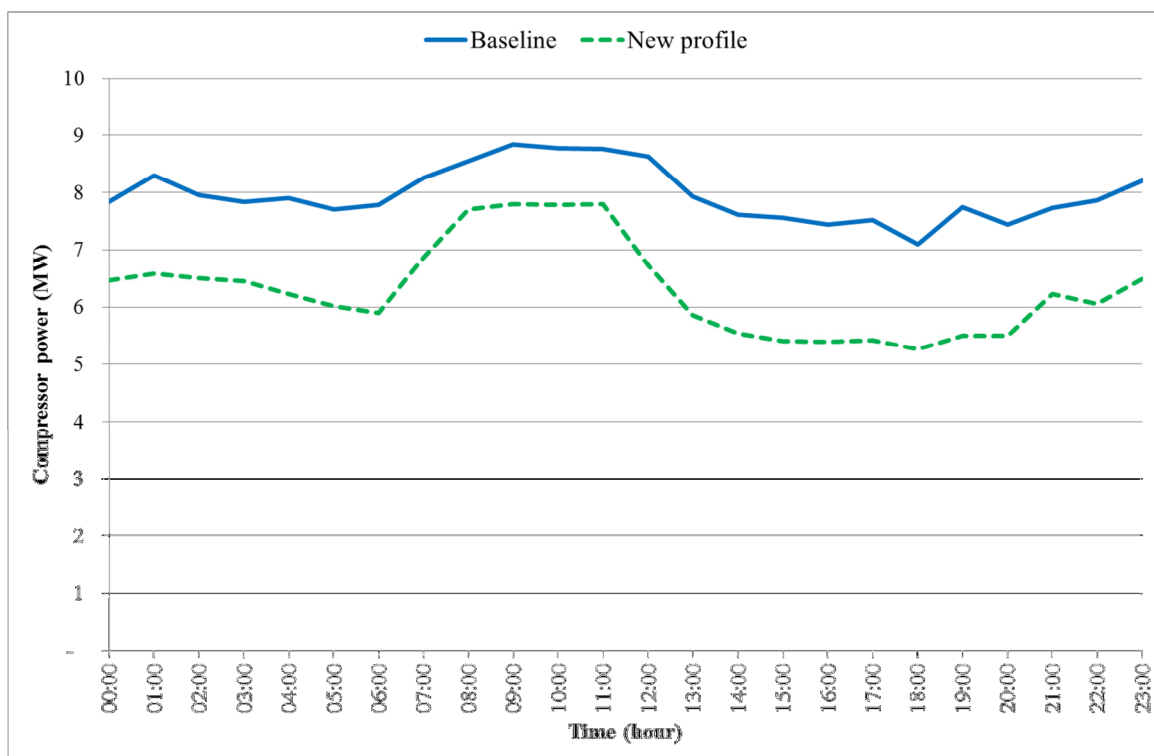

Figure 60 – Comparison between baseline and improved power profile for Mine B

The leak repairs were done based on leaks recorded by an external leak-detection company appointed by the mine. The leak-detection company made use of ultrasonic leak-detection equipment to estimate the flow consumed by the leaks. They estimated that the leaks detected by them contributed to a constant compressed air demand of 24 800 m<sup>3</sup>/h. Empirical analysis of data for a typical mine compressed air system showed that 86 W of electrical power is required to generate compressed air to 500 kPa at a rate of 1 m<sup>3</sup>/h. A compressed air demand of 24 800 m<sup>3</sup>/h would therefore result in an average electricity demand of 2.1 MW.

The mine fixed some of the leaks after they were discovered. A follow-up leak-detection survey revealed that some of the leaks were repaired after they were detected by the leak-detection company. The leak-detection company estimated that a saving of 12 000 m<sup>3</sup>/h was realised after these leaks were fixed. This equates to a saving of approximately 1 MW. Further spot checks three months after the second leak-detection survey revealed that more leaks were fixed. It also revealed additional leaks not detected during the first leak survey.

It would therefore be difficult to quantify the contribution of the leak repair to the total saving of 1.7 MW that was achieved. The manual compressor control tests and the simulations proved that a saving of between 0.9 MW and 0.98 MW would be achieved through improved compressor control. It is thus assumed that the additional saving was due to leak repair.

#### **4.4 Mine C: Multiple shafts, multiple compressor houses, processing plant**

Mine C will be discussed in more detail as an example of a system that has three baseload compressors that may not be stopped and started on a regular basis. Underground control valves were already installed at Mine C during a previous project. The results of the project were discussed in Chapter 2 and the mine was referred to as Mine 9. The mine will now be referred to as Mine C to be consistent with the case study naming convention.

At Mine C there is a processing plant that requires a constant compressed air supply. The compressor situated at the plant is not used under normal circumstances. Compressors situated at the shafts must therefore pressurise the entire compressed air system to supply the plant. The compressed air system consists of eight centrifugal compressors. A simplified layout of the surface compressed air system is shown in Figure 61.

## Results

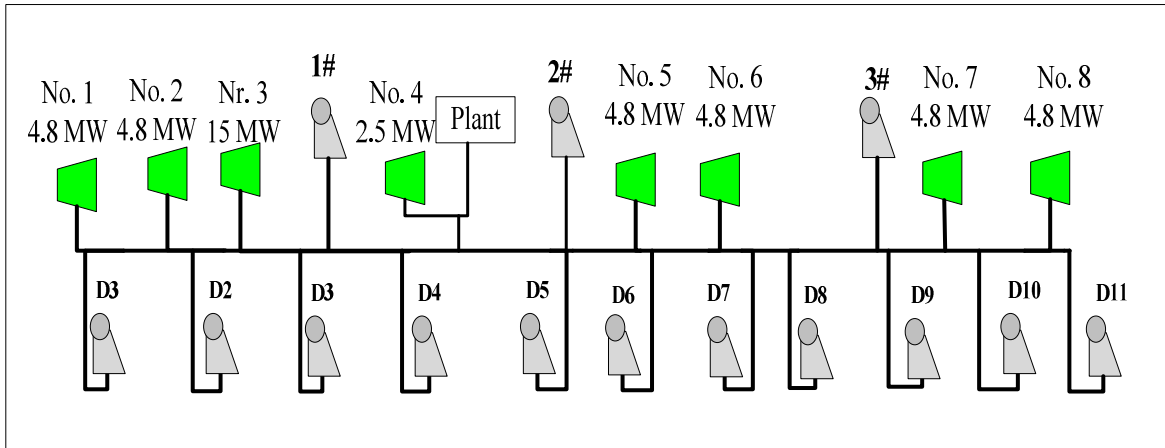

*Figure 61 – Simplified compressed air system layout for Mine C*

A summary of the compressor specifications and other information is summarised in Table 9. It is noted from the table that three of the compressors do not have capacity control. The inlet valves on these compressors can only be operated in the fully open, fully closed or partially open positions. The partially open positions are only used during start-up and unloaded operation.

*Table 9 – Summary of compressors at Mine C*

<b>Compressor name</b>	<b>Location</b>	<b>Designed flow capacity (m<sup>3</sup>/h)</b>	<b>Electrical motor capacity (kW)</b>	<b>Capacity control</b>	<b>Baseload / top-up compressor</b>
No.1	1 Shaft	51 000	4 800	Installed	Top-up
No.2	1 Shaft	51 000	4 800	Installed	Top-up
No.3	1 Shaft	112 800	15 000	Installed	Baseload
No.4	Plant	25 480	2 500	No	Emergency
No.5	2 Shaft	51 000	4 800	No	Baseload
No.6	2 Shaft	51 000	4 800	No	Baseload
No.7	3 Shaft	51 000	4 800	Installed	Top-up
No.8	3 Shaft	51 000	4 800	Installed	Top-up

All eight compressors have PLCs installed to perform certain control functions. Their functionality is, however, limited. Dedicated compressor operators monitor the operation of the compressors. They are also responsible to stop and start the baseload machines according to the system pressure. Compressor 3 has to be stopped and started by skilled artisans such as electricians.

Compressor information can be monitored on a SCADA system installed at a central control room. Under normal running conditions the compressor attendants at the three different locations do not communicate with each other. As a result the operators at 1# and 2# could start two compressors simultaneously. This could result in the operation of more than the actual number of compressors required and leads to unnecessary electricity consumption.

The first step in reducing electricity consumption of mine compressed air systems was to have proper compressor control. A constraint at Mine C was that mine employees were not keen on the automatic operation of the compressors. They believed that the risk of automatic control was too high. A further problem at Mine C was the limited capacity control due to the two fixed-capacity baseload compressors at 2#. The control systems installed on these compressors would operate the blow-off valves when the system pressure reached 600 kPa.

The capacity control system installed on Compressor 3 at 1# could only reduce supply capacity to 65% of maximum capacity. A flow demand below 65% resulted in operation of the blow-off valve to prevent surge. Compressed air demands lower than the supply capacity of the three compressors would therefore not reduce electricity consumption. The baseline compressor power consumption together with the system pressure at the three shafts is shown in Figure 62.

## Results

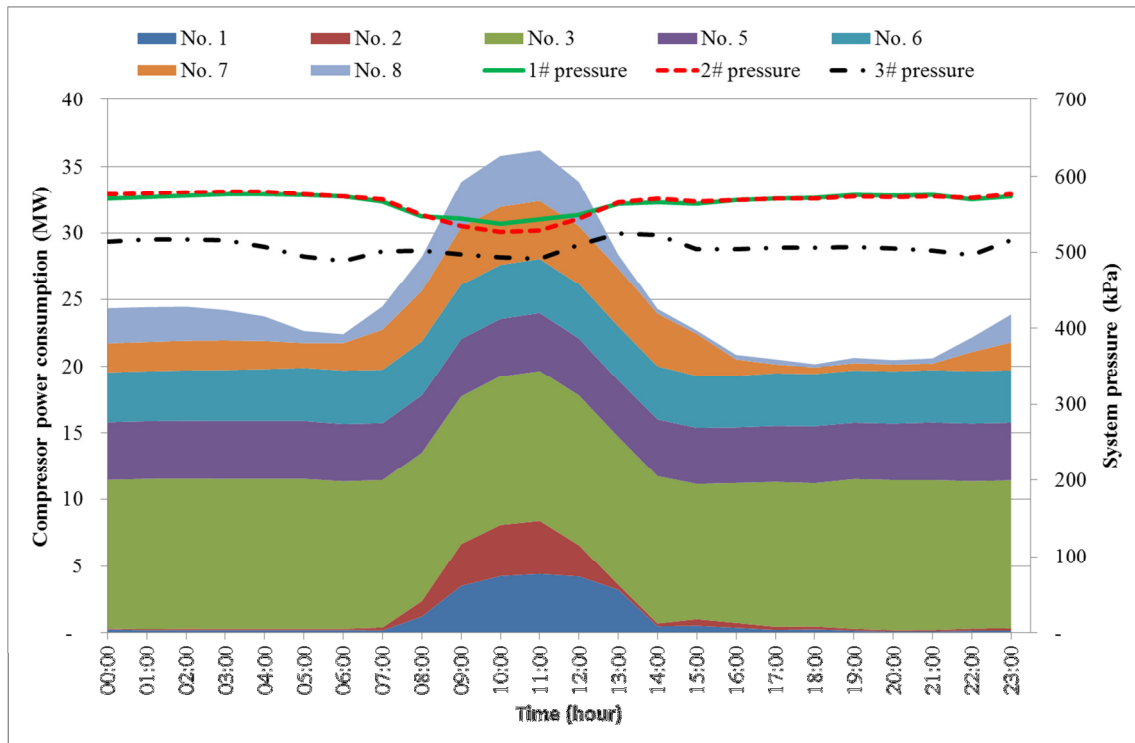

Figure 62 – Baseline compressor power consumption for Mine C

The system pressure shown in Figure 62 indicates a drop in air pressure during the peak production shift. Previous research suggests that this is an indication that the compressed air supply is more than the demand during off-peak periods. Thus there is a likely possibility to reduce compressor power consumption during off-peak periods. This was investigated further by analysing the flow supply, distribution and demand of the system.

The data analysis showed that it would be possible to supply the required flow demand with a revised compressor control strategy. Simulation results proved that a daily average saving of 2.2 MW could be achieved by limiting the operation of the top-up compressors. The possibility to use the compressor situated at the plant as a top-up compressor was also investigated. The simulation model predicted that the saving could be increased to 5 MW if this compressor is available. This drastic increase in savings would be a result of the permanent shutdown of one of the baseload compressors situated at 2#.

The second step towards power reduction on mine compressed air systems was to install surface control valves to reduce compressed air demand. The possibility to increase the savings by using control valves was investigated. Underground control valves were already installed at the two main production shafts at Mine C as mentioned before.

A simulation model was configured to predict the savings if surface control valves were installed at all of the shafts that did not have underground valves installed. Simulated results indicated that valve control would increase the saving from 2.2 MW to 2.6 MW. The simulation model predicted that the saving with the use of the plant compressor would be increased to 5.2 MW with surface valve control.

Tests were conducted to determine whether it would be possible to operate with only one compressor at 2# if the plant compressor was used. The tests proved that a saving of 4.5 MW could be achieved through the revised compressor operation. These tests were conducted prior to the installation of surface control valves. The saving was therefore 500 kW less than the predicted saving of 5 MW without surface valve control. The predicted savings was within 10% of the actual savings.

The successful results from the test led to the implementation of a project that involved: surface valve control, refurbishment of the underground control valves at the two main production shafts, upgrades to the plant compressor, and a revised compressor control strategy. The control valves were commissioned long before the plant compressor. This was due to unforeseen project delays that were experienced with the upgrade of the plant compressor.

A graphical representation of the compressor power consumption after the implementation of the control strategy and the control valves are shown in Figure 63. The average saving achieved for the first three months after the control valves were commissioned was 2.8 MW. This is within 8% of the predicted saving of 2.6 MW. The average saving of 2.8 MW is equivalent to a yearly cost saving of R6 million (2012/2013 tariffs). A comparison between the baseline, the simulated results and the actual results is shown in Figure 64. It is observed from the figure that the simulated results closely represent the actual results.

## Results

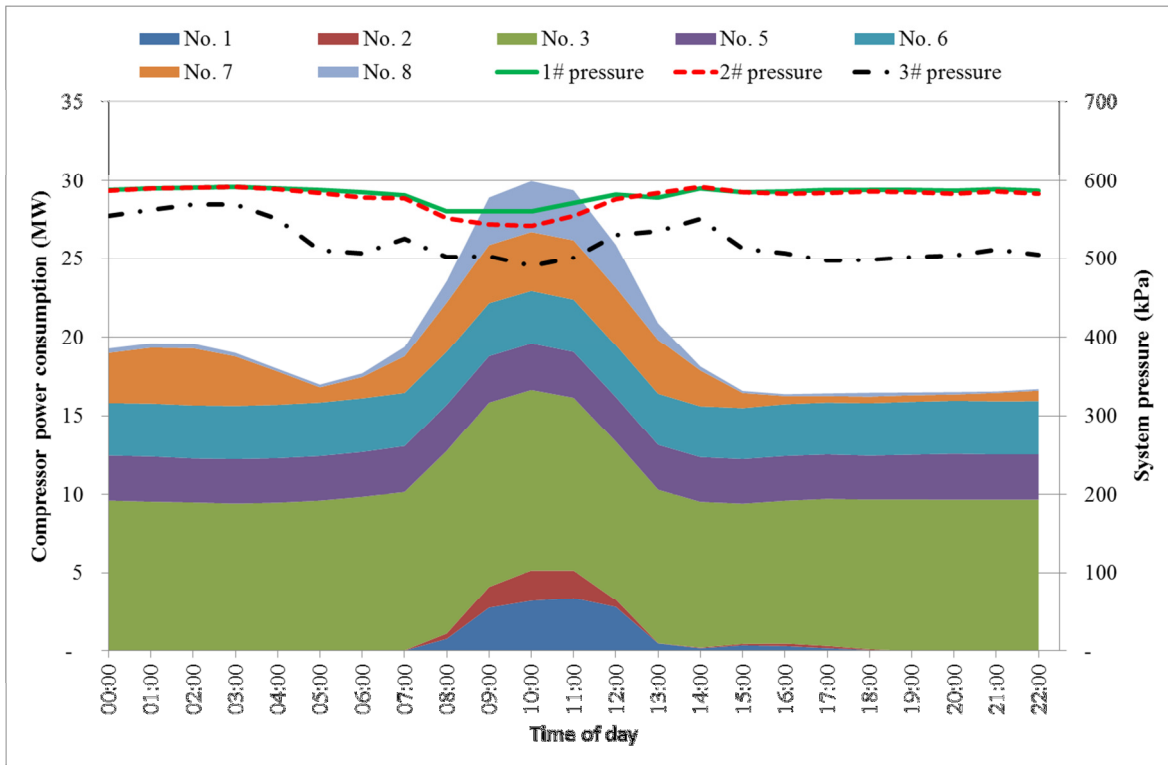

Figure 63 – Compressor power consumption after project implementation for Mine C

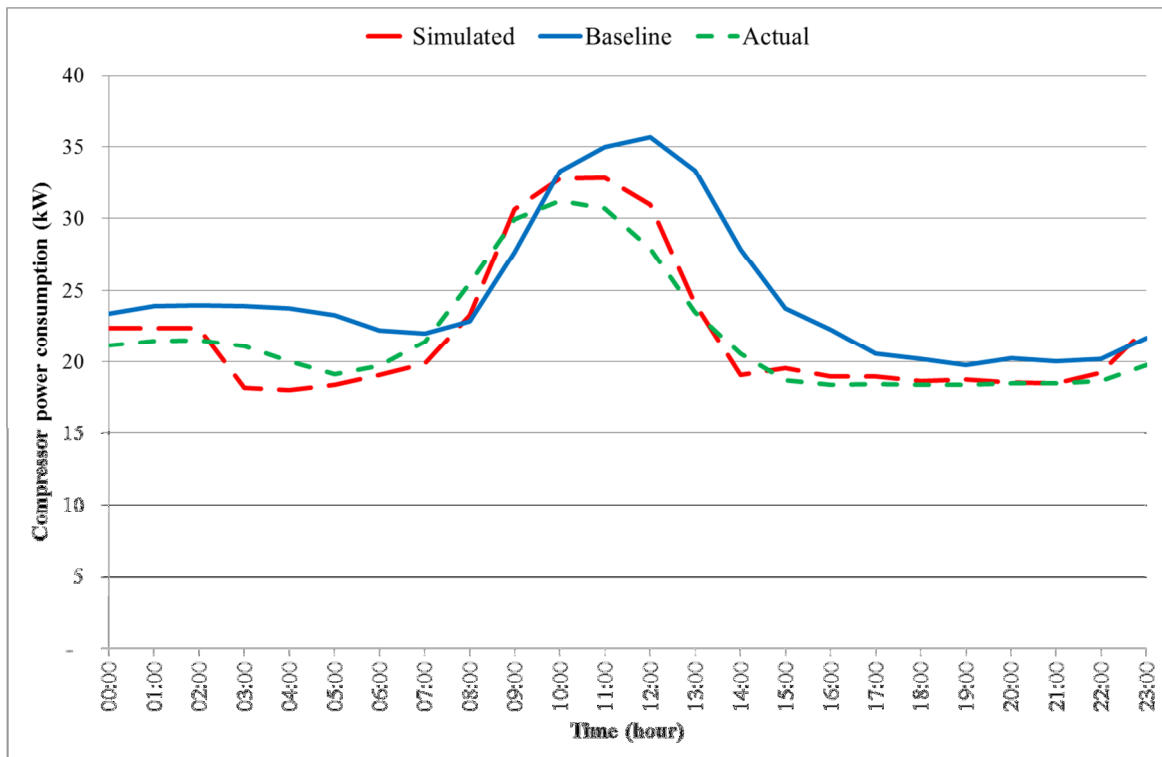

Figure 64 – Comparison between simulated and actual profiles for Mine C

#### 4.5 Mine D: Multiple shafts, multiple compressor houses, several high-pressure users

The compressed air system at Mine D consists of twelve compressors connected to eight shafts via an extensive surface pipe network. Compressed air at the shafts is reticulated through underground piping networks to the working areas. Several surface areas such as workshops, pneumatic loading systems, and so forth are also supplied with compressed air from the surface compressed air piping systems. A simplified layout of the compressed air system at Mine D is shown in Figure 65.

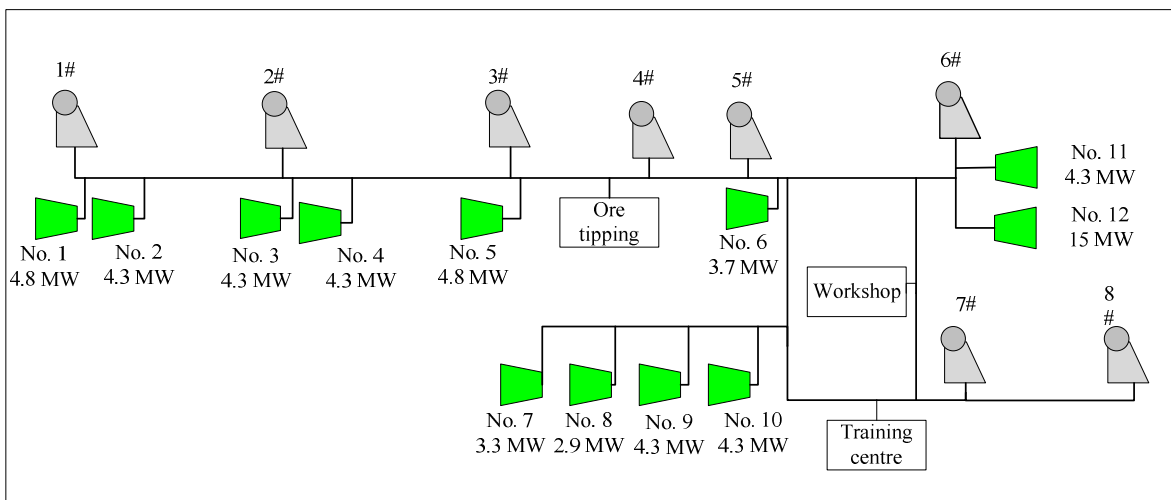

Figure 65 – Simplified layout of the surface compressed air system for Mine D

Some of the pneumatic equipment situated on surface (such as the ore-loading systems) requires a constant pressure of approximately 500 kPa while in operation. An example is the loading boxes situated underneath the ore silos at the shafts. Railway trains are filled with ore when passing underneath the silos. The silos' loading box doors are operated by means of pneumatic cylinders. An example of a pneumatic cylinder fitted to a loading box door is shown in Figure 66. The loading schedules depend on various factors such as the silo levels at the processing plants, as well as the silo levels at the different shafts.



*Figure 66 – Pneumatically operated loading box door on surface silo at Mine D*

Trains are used to transport ore from the shafts to the processing plant. The trains are fitted with pneumatically operated unloading doors to empty the ore at the processing plant. An example of a pneumatic cylinder installed on a train is shown in Figure 67. These pneumatic cylinders require approximately 500 kPa to operate sufficiently. The unloading schedules at the plant do not follow the typical mining schedules. The entire compressed air ring must therefore be continuously pressurised to at least 500 kPa to ensure that the pneumatic cylinders on the trains operate sufficiently while unloading.



*Figure 67 – Pneumatic cylinder used to operate train doors at Mine D*

The training centre is another constant high-pressure user at Mine D. The training facilities are used to teach trainees to operate the pneumatic equipment used at the mine. The training centre does not follow a typical mining schedule. The training centre requires a constant compressed air supply during times that the shafts could operate at lower pressures.

Mine personnel manufacture and repair some of the mining equipment at onsite workshops. Pneumatic tools are quite often used to perform these tasks. The working shifts for these employees do not follow typical mining schedules. The pneumatic tools would therefore also require higher pressures than the shafts during times such as blasting periods.

A solution to isolate the continuous high-pressure users - the shaft loading systems, train-unloading systems, training centres and the workshops - could therefore allow reduced system pressures when the shafts require lower pressures. The amount of compressed air consumed by the shafts is much more than that consumed by these other users.

The simplified model was used to analyse the possible savings at Mine D. The compressors at Mine D are automated and it is possible to control them from a central control room. The first step towards improving electricity consumption on mine compressed air systems was to ensure that the compressed air supply met the compressed air demand. The baseline compressor power consumption at Mine D is shown in Figure 68.

The baseline system pressure indicates that the system pressure is reduced during the Eskom evening peak. This is the result of an Eskom peak-clip project (discussed as Mine 10 in previous sections). The control room operators at the central control room had to ensure that the supply met the compressed air demand. Operators stopped and started the compressors according to the demand.

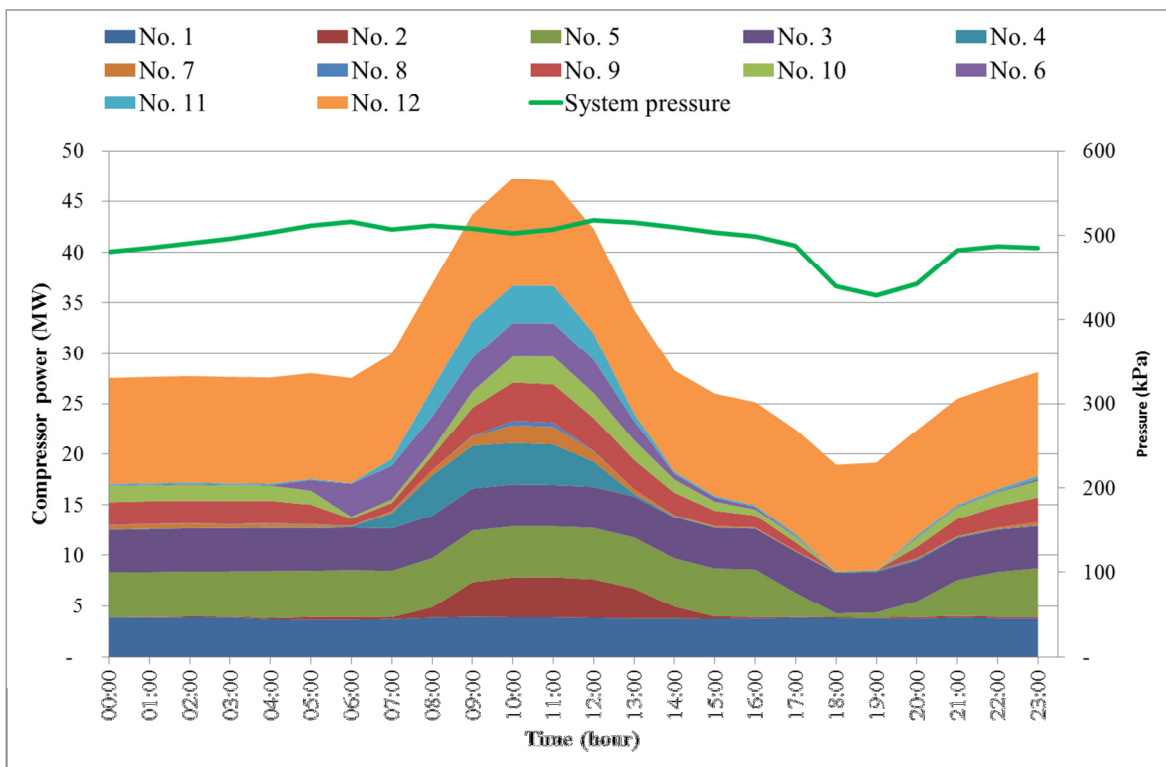

Figure 68 – Baseline compressor power consumption at Mine D

## Results

The second step towards achieving savings was to control the compressed air consumption at the shafts. The varying pressure requirements of the shafts could be controlled by valves while still maintaining the surface system pressure to satisfy the requirements of the loading boxes, training centres and so forth. The potential benefit of the control valves can be calculated by using simulation models.

Unavailability of electronically logged data on the compressors made it impractical to use complex simulation models with great accuracy. A simplified simulation model was used instead. The simplified simulation model was used to predict the compressor power consumption if control valves were to be used to restrict shaft compressed air consumption during non-peak drilling periods. The results of the simulation model are shown in Figure 69. The simulation model predicted an average daily saving of 4.0 MW.

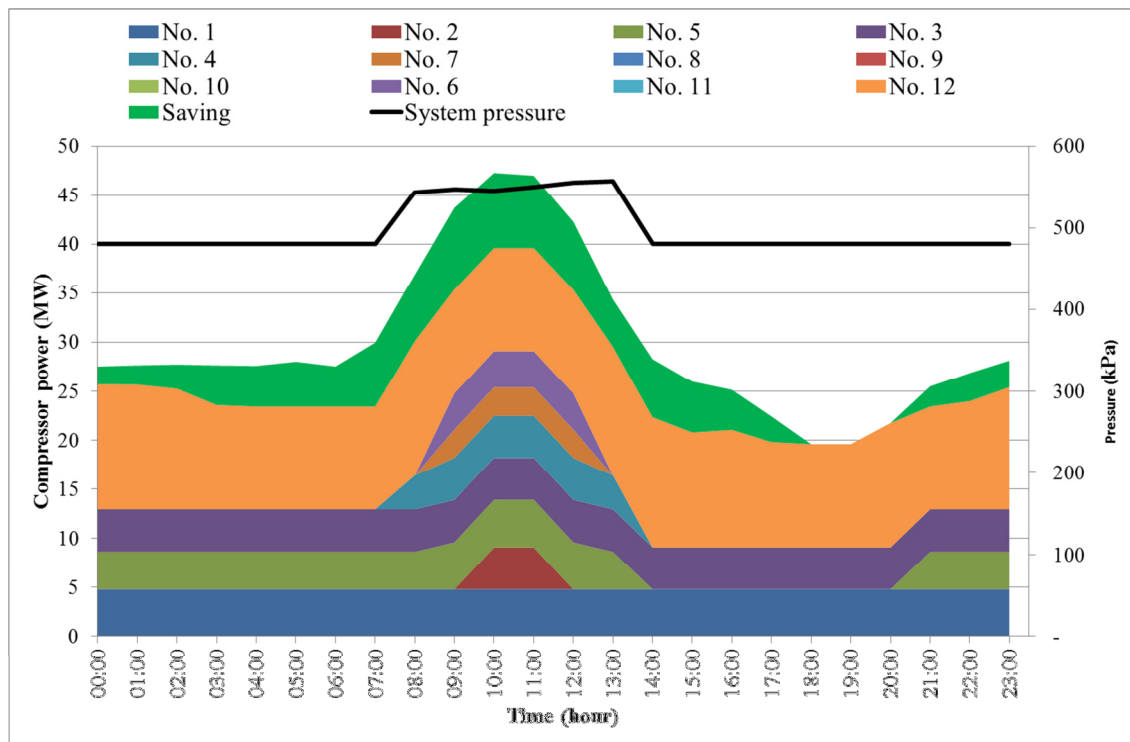

Figure 69 – Estimated compressor power consumption at Mine D using surface valve control

The simulation model was then used to quantify the effect of isolating constant pressure applications on surface from the main compressed air system. The simulated results suggest an average energy efficiency saving of 4.9 MW if combined with the surface valve control at the shafts.

The isolation of the surface constant high-pressure applications could consequently increase the saving by approximately 900 kW according to the simulation model. The simulated results are shown in Figure 70.

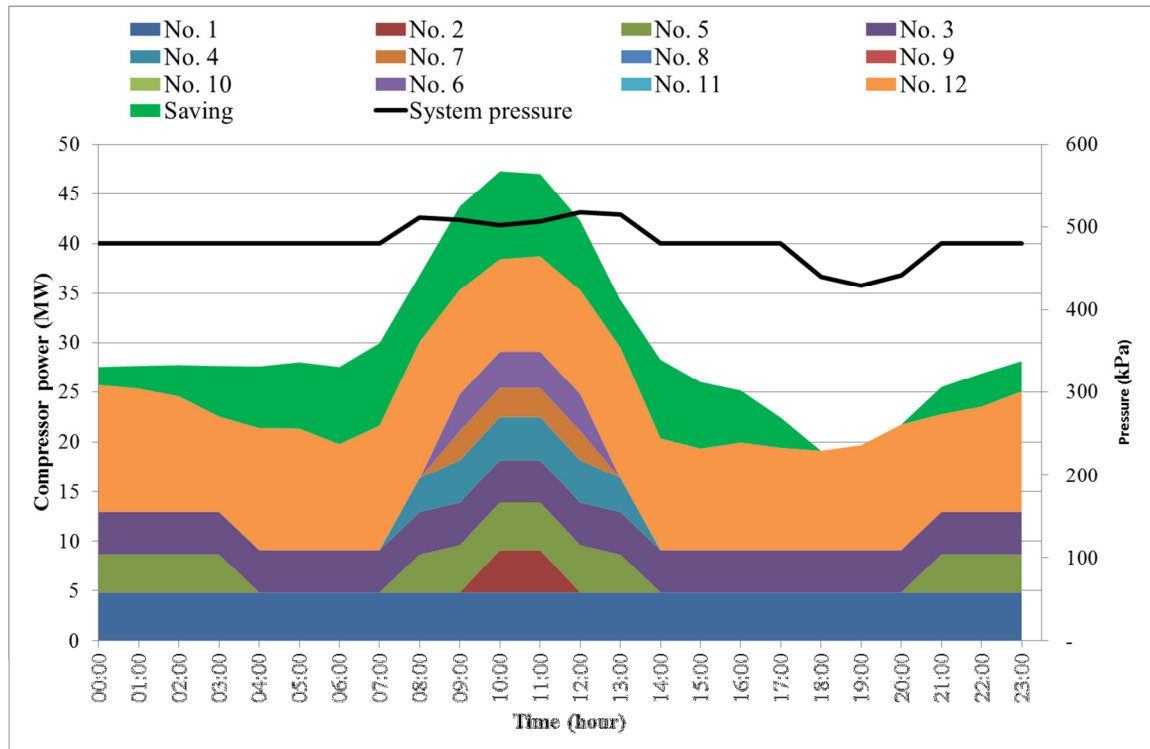

Figure 70 – Simulated results for surface pressure control and isolation of high-pressure consumers at Mine D

The next step towards reducing electricity consumption of mine compressed air systems is to control underground distribution. The three highest production shafts at this mining complex were already equipped with isolation valves on selected underground levels. These isolation valves could be opened or closed from surface to reduce compressed air consumption during blasting periods.

An energy efficiency project was implemented at Mine D. The project involved the installation of surface control valves at the shafts. Dedicated compressors were installed to isolate the training centre, the train-unloading point at the processing plant, as well as the workshops. The pneumatic loading systems at the surface silos were replaced with hydraulic alternatives. The results obtained during the three-month performance assessment of the project are shown in Figure 71.

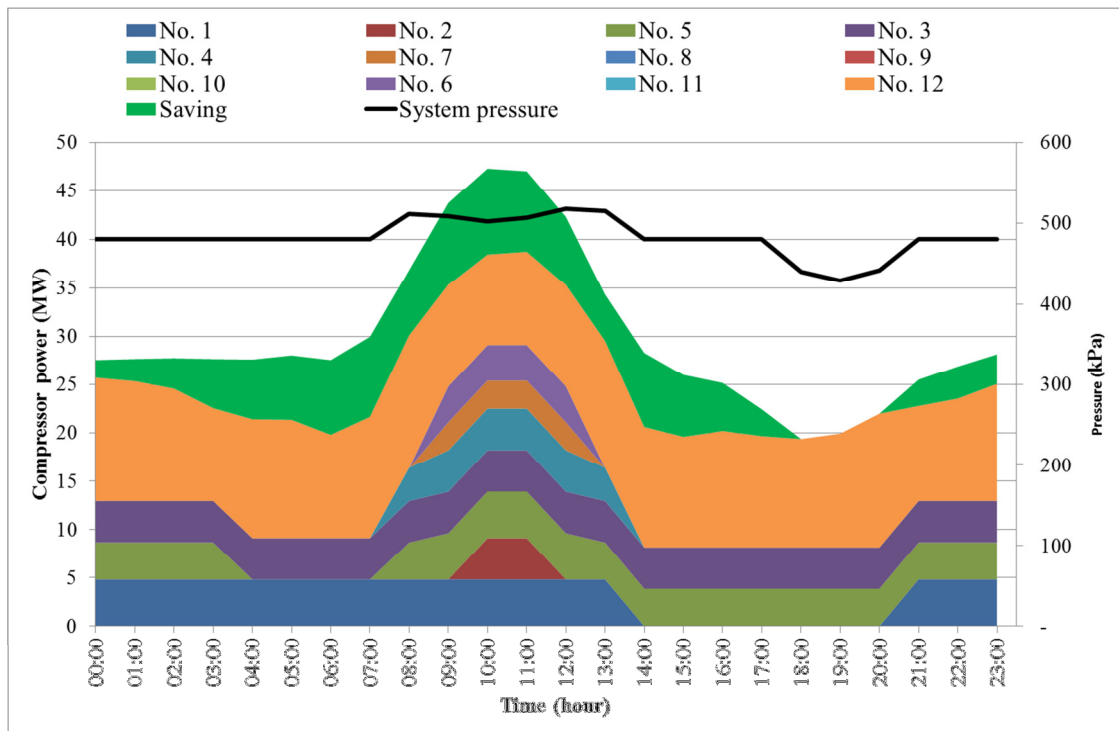

Figure 71 – Compressor power consumption during performance assessment at Mine D

The implementation of surface control valves together with the isolation of the constant high-pressure consumers realised a saving of 5.7 MW during the performance assessment period. This is equivalent to an annual electricity cost saving of R17 million. The actual saving was 19% higher than the predicted saving. The simulated results achieved for Mine D are not as accurate as the results achieved for the other case studies. This is due to assumptions that were made to estimate the power consumption of the compressors for certain flow requirements.

## 4.6 Application to South African mines

The aim of the study was to obtain an integrated approach to reduce compressor power consumption on South African deep-level mines. Results from projects that were implemented on twenty-two mine compressed air systems were studied to determine the impact of different initiatives. A comparison between the baseline compressor power consumption and the new resultant profiles is shown in Figure 72.

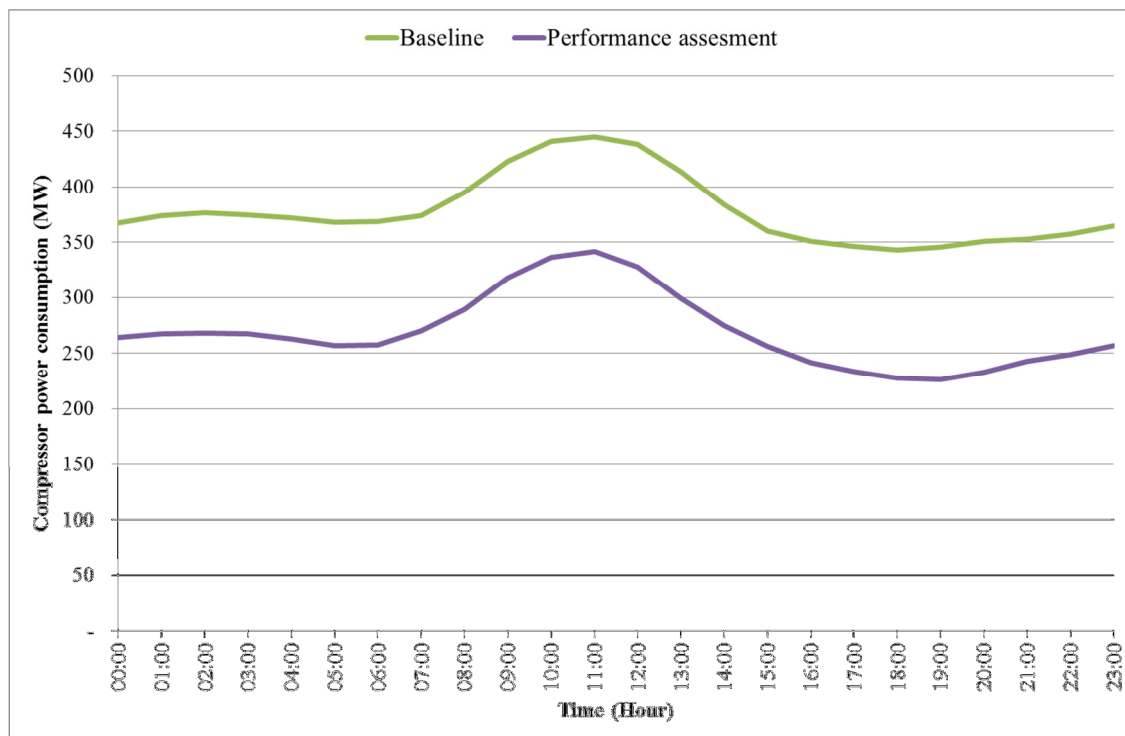

Figure 72 – Energy saving results for projects implemented on twenty-two mine compressed air systems

A new integrated approach was developed summarising the different approaches in three steps. The new methodology was used as the fundamental principle to investigate and analyse energy saving possibilities on these mine compressed air systems. Four of these projects were discussed in detail as Mine A, Mine B, Mine C and Mine D.

## Results

---

The results from the other projects will not be discussed in detail since they were all based on the same principles. It was not feasible to implement all three steps of the integrated approach on all of the systems. The results from the projects were grouped according to the three steps of the integrated approach. The first step of the integrated approach focused on improving the supply of compressed air.

The compressed air systems at two mines were only improved using step one. These mines were scaling down on production that did not make the implementation of other techniques viable. The results obtained from these two projects are shown in Figure 73. An average daily saving of 9 MW was achieved. This is equivalent to a yearly electricity cost saving of approximately R24 million.

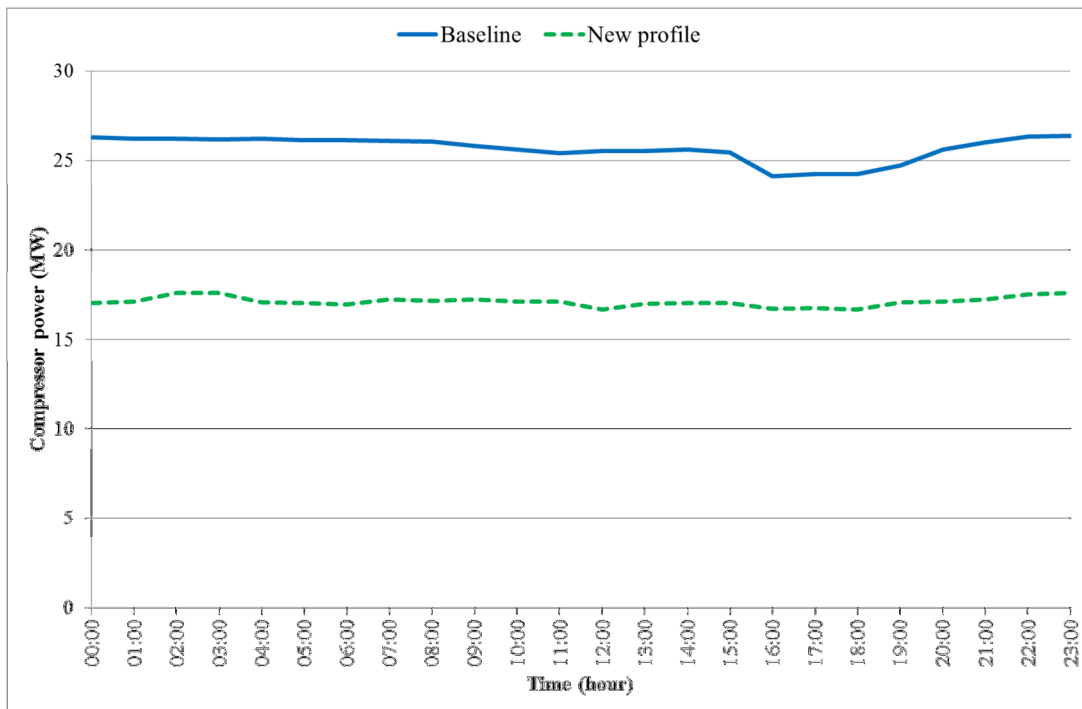
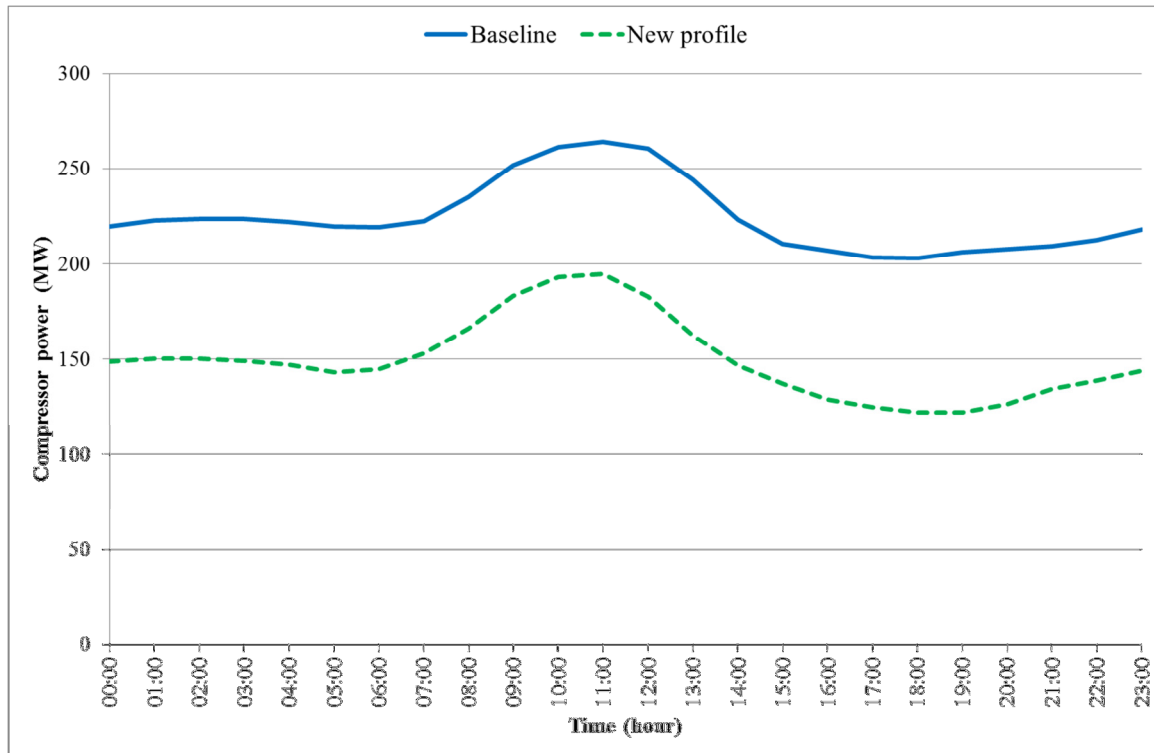

Figure 73 – Results obtained from projects that aim to match compressed air supply with demand

The second step of the integrated approach focused on surface demand control. The first and second steps of the integrated approach were implemented on ten mine compressed air systems. It was not financially viable to implement all three steps at these ten mines. These projects comprised a combination of improvements to the compressor control systems and surface demand control initiatives.

## Results

The results from these projects are shown in Figure 74. These projects resulted in an average daily saving of 75 MW. This is equivalent to an annual electricity cost saving of approximately R215 million.

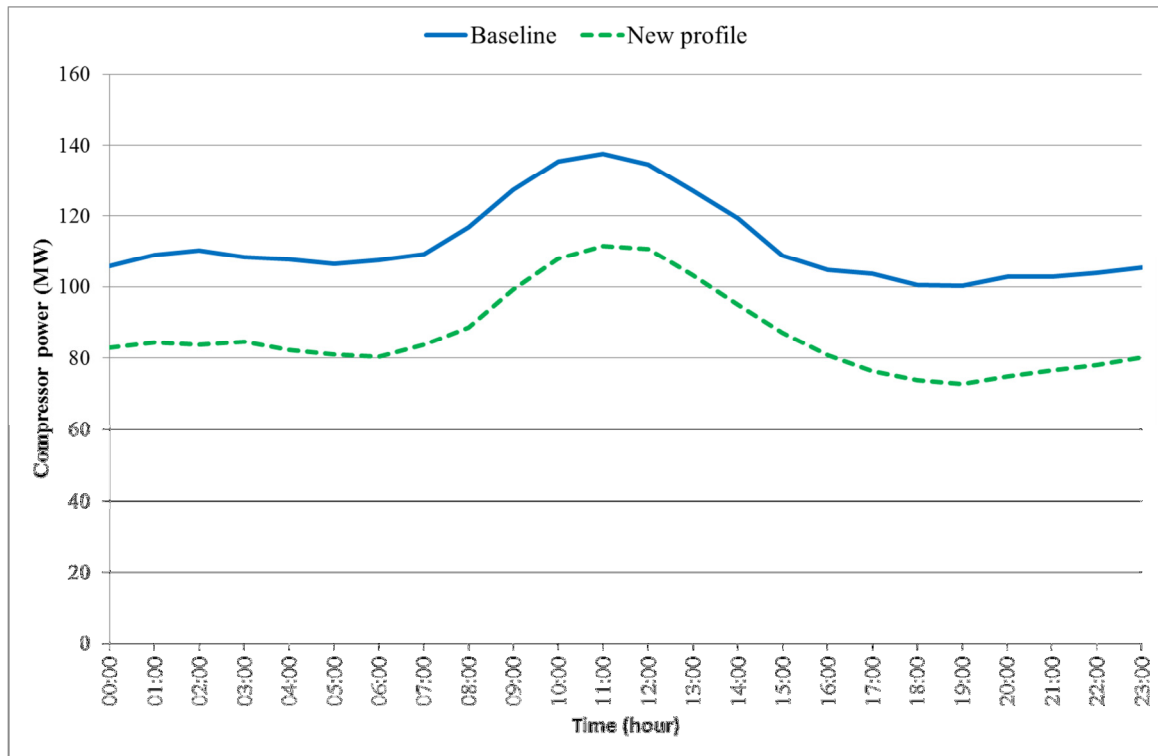

*Figure 74 – Results from projects with surface pressure control valves*

The third step of the integrated approach was the installation of underground control valves. All three steps of the integrated approach were implemented on ten mine compressed air systems. The results from these projects are shown in Figure 75. These projects resulted in a total saving of 26 MW. This is equivalent to a yearly electricity cost saving of approximately R75 million.

The total impact of the projects implemented on the compressed air systems considered in this study is shown in Figure 76. A total average saving of 109 MW was achieved as a result of these projects. Compressor power consumption was reduced by 30% on average. This relates to an estimated annual electricity cost saving of R315 million (2012 tariffs).

## Results



*Figure 75 – Results from the implementation of underground control valves*

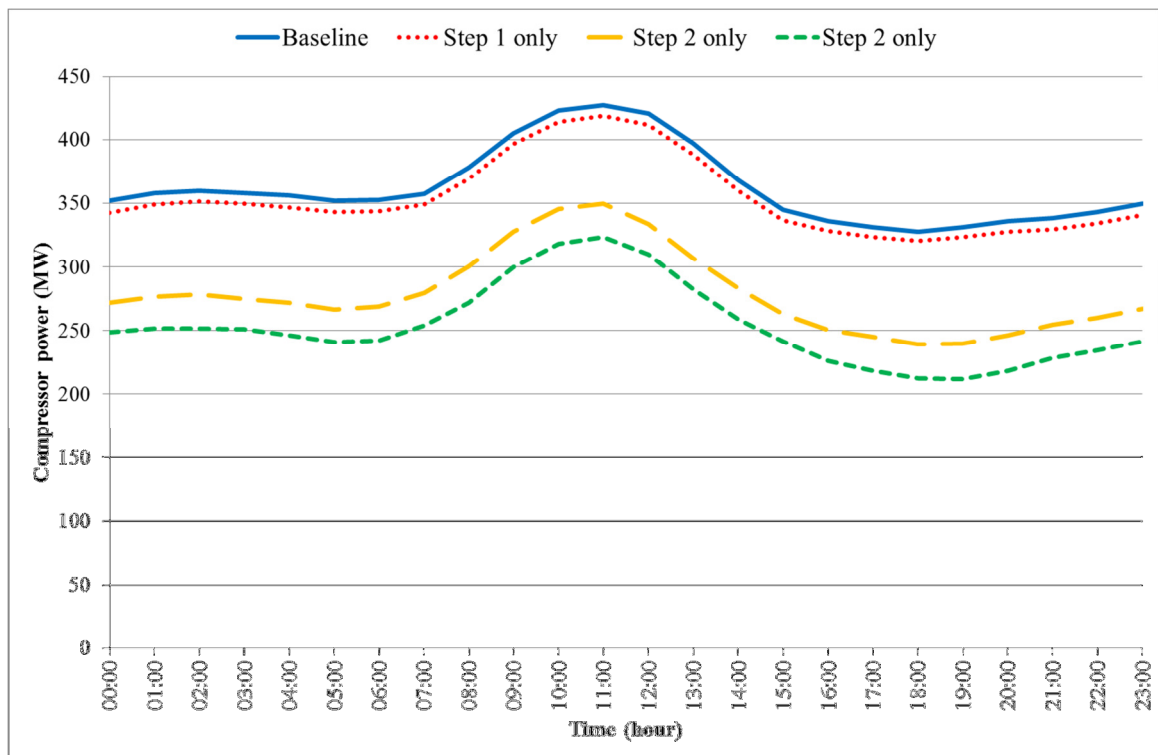

*Figure 76 – Total impact of projects considered during this study*

An average saving of 109 MW would result in an annual electrical energy reduction of 0.96 TWh. The environmental benefit of these projects can be calculated by using the environmental impact figures provided in Table 10 [3].

*Table 10 – Environmental impact of projects [3]*

	<b>Reduced usage/emissions as a result of a 0.96 TWh reduction in electricity consumption</b>
Coal use	0.54 Mt
Water use	1.36 MI
Ash produced	153.85 t
Particulate emissions	0.31 t
CO <sub>2</sub> emissions	0.98 Mt
SO <sub>x</sub> emissions	7.86 t
NO <sub>x</sub> emissions	4.16 t

South Africa consumed 240.09 TWh of electrical energy during 2010 [3]. The savings achieved as a result of these projects are therefore equivalent to 0.4% of South Africa’s total electricity consumption. The projects resulted in an average compressor power reduction of 30%.

The implementation of the integrated approach could be applied to other industrial compressed air systems. Worldwide industrial compressed air generation consumes approximately 889 TWh of electricity per annum. A 30% reduction in electrical consumption on all industrial compressed air systems has the potential to reduce global electricity demand by 267 TWh. That is more than South Africa’s total electricity consumption.

## 4.7 Financing options

The main focus of mining operations is to extract valuable resources. Mine management is more likely to invest in projects that could increase production output than in projects that reduced energy consumption. The financial benefit of these projects can be used to motivate funding for their implementation.

The projects discussed in this study realised an average yearly saving of approximately R315 million. Eskom provides additional funding for energy efficiency projects as part of their Demand Side Management programme. Funding obtained through the DSM models is sometimes a key requirement to ensure that the return on investment for energy saving projects conform to company requirements [66].

The Eskom DSM programmes include different options to fund energy efficiency projects. Not all of these funding programmes would be suitable for energy efficiency projects on compressed air systems. Eskom DSM programmes that could be used to fund energy efficiency projects on mine compressed air systems include: the standard offer programme; the Energy Service Company (ESCO) model; and performance contracting [67].

ESCOs serve both Eskom and other customers to realise energy cost saving measures. Eskom is prepared to assist with funding of feasible projects subject to certain conditions such as a minimum saving of 100 kW [5].

The benchmark funding values for different Eskom programmes are summarised in Table 11. Compressed air projects will qualify for Eskom funding at a rate of R4.4 million per MW. A total saving of 109MW would therefore qualify for a R480-million subsidy under the ESCO model

Table 11 – Summary of benchmark funding values for the ESCO model [5]

<b>Programmes</b>	<b>Benchmark values (amount per MW saving)</b>
Lighting and HVAC	Up to R5.2 million
Hot Water	Up to R6.3 million
Demand Response	Up to R3.9 million
Compressed Air	Up to R4.4 million
Process Optimisation	Up to R5.2 million
Other	Up to R5.2 million

The Electricity Regulation Act of 2006 requires compliance with energy efficiency standards and DSM. The Republic of South Africa’s Department of Energy (DoE) recognised that energy efficiency initiatives are good alternatives to solely focusing on increasing South Africa’s electricity generation capacity. A policy to support the Energy Efficiency and Demand Side Management Program (EEDSM) for the electricity sector through the Standard Offer Incentive Scheme was therefore developed by the DoE [68].

The aim of the Standard Offer Incentive Scheme is to provide a means to sell energy or demand savings at a predetermined rate to a utility company such as Eskom. The savings can be sold at a predetermined rate such as R/kWh or R/kW. The purchase prices can be determined by considering the cost to supply electricity by the utility. ESCOs, equipment suppliers or other organisations will then be paid at the applicable rates once the projects have been completed and the savings verified.

The standard offer programme used by Eskom makes use of an arrangement where the ESCO or project supplier will receive a payment of 70% of the initial purchase price after the project is commissioned. The outstanding balance is paid at annual payments of 10% over a period of three years. Adjustments are made to these payments if the anticipated savings are not achieved. This ensures sustainability of the projects for three years [67].

The initial purchase price for the project is calculated by multiplying the expected annual kWh saving with the applicable rebate rate. The expected annual savings are determined by a certified M&V entity after project completion. The rebate tariffs for different technology types are funded at the rates shown in Table 12.

A saving of 109 MW is equal to a 0.96 TWh reduction in electricity consumption per annum. The project will therefore qualify for an Eskom contribution worth R401-million with the standard offer program. [67]

*Table 12 – Rates applicable for the Eskom standard offer [67]*

<b>Technology type</b>	<b>Rebate rate (R/kWh)</b>
Energy efficient lighting systems	0.42
LED lighting technologies	0.55
Building management systems	0.42
Hot water systems	0.42
Process optimisation	0.42
Industrial and commercial solar water systems	0.70
Renewable energy	1.20

Performance contracting is another possible funding mechanism provided by Eskom. This funding mechanism is aimed at energy efficiency projects with savings on weekdays between 06:00 and 22:00. The minimum project size for performance contracting is 30 GWh that must be sustained over a period of three years. All project costs for these projects must be carried by the project developer/ESCO until savings have been measured and verified. The rate paid by Eskom for these projects is determined by an offer from the project developer or through a bidding process.

Another funding option that was considered is the Clean Development Mechanism (CDM). CDM is defined under Article 12 of the Kyoto Protocol. The aim of the Kyoto Protocol to the United Nations Framework Convention on Climate Change (UNFCCC) is to limit or reduce greenhouse gas emissions in so-called “Annex I” countries. Annex I countries made the commitment to reduce or limit overall greenhouse gas emissions in the period from 2008 to 2012 by at least 5% from the emission levels in 1990 [69].

The purpose of the CDM is to assist countries not included as Annex I countries to achieve sustainable development and to contribute to the objective of the Convention on Climate change. The CDM can also be used by Annex I countries to assist them to comply with their emission and reduction commitments under the Kyoto Protocol [69].

Annex I countries can acquire Certified Emission Reductions (CERs) by implementing emission-reduction projects in developing countries. CER credits are equivalent to one tonne of CO<sub>2</sub> and can be traded to ensure that an Annex I country reaches its commitments under the Kyoto Protocol [69].

One of the criteria for acquiring CERs from emission-reduction projects is that the projects must result in emission reductions that are additional to any emissions that would have occurred in the absence of the project activity [69]. Eskom DSM-funded energy efficient projects require additional funding from the client. An energy efficiency project could be classified as additional if the project was not financially viable for the client. An example of such a scenario is a payback period that exceeds the normal project evaluation criteria of a company.

Other factors such as carbon tax and Energy Conservation Scheme (ECS) penalties can also be considered to analyse the financial feasibility of projects. The implementation of carbon taxes and ECS penalties will greatly improve the payback periods of energy efficiency projects [70]. The magnitude of the additional expenditure due to carbon taxes and ECS penalties has not been finalised as yet [70], [71]. Financial analysis of energy efficiency projects according to electricity tariffs only would provide a much more conservative payback calculation.

The ESCO model provides the most lucrative funding model since it provides more funding than the standard offer program and the project developer does not have to wait three years to recover all of the projects costs. The ESCO model was used to apply for funding for all of the projects. The shortfall in costs could be financed by the mine. Projects to the value of R795 million would be financially feasible based on the assumption that the mining clients would require a payback period of 12 months after project completion and that Eskom would provide funding at R4.4 million per MW.

All of the projects considered in this study were partially or fully funded by the Eskom DSM programme. The actual costs of the projects will not be provided since these costs are considered confidential. The payback periods of all of the projects were within normal budget allowances of the mines. These projects were therefore not considered to be additional so CDM funding options were not considered.

### **4.8 Conclusion**

The integrated approach was applied to mine compressed air systems on twenty-two deep-level mines in South Africa. The results from four of the twenty-two projects were described in detail in the previous sections. The simplified model approach was followed to estimate the savings of the projects.

The first case study was implemented at Mine A. The compressed air system at Mine A consists of only one compressor house with five centrifugal compressors with installed capacities of 2.6 MW each. Energy efficiency opportunities were investigated based on the simplified approach. The results obtained from the analysis indicated that the optimisation of the compressor control system would result in the most effective solution with an estimated daily energy efficiency of 2.72 MW.

A specialised compressor control system was implemented to ensure that the compressed air system is not operated at unnecessarily high pressures. The new control system also ensures that only the minimum number of compressors is operated at any time. The average weekday saving achieved at Mine A was 2.45 MW. The actual saving was therefore within 10% of the predicted saving.

The integrated approach was also implemented at Mine B. The compressed air system at Mine B comprises three shafts and three compressor stations. The shafts and the compressors are linked with a pipe network situated on surface. The integrated approach was used to identify the focus areas for energy savings initiatives.

Analysis of the baseline pressure revealed an oversupply of compressed air during the non-drilling periods. This was due to pressure set points that were too high. The simplified simulation model was used to investigate the impact from a reduction in system pressure. The simulation model provided an estimated saving of between 0.9 MW and 0.98 MW. A manual compressor test confirmed that a saving of 0.97 MW could be achieved by reducing the set points.

An average saving of 1.7 MW was achieved during the performance assessment of the project. The additional 0.73 MW saving was achieved through leak repair. A 1.7 MW saving relates to an annual electricity cost saving of R4.7 million.

The third case study was implemented at Mine C. Mine C consists of multiple shafts with four compressor houses as well as a metal processing plant that require a constant compressed air supply. The compressed air system comprises of eight compressors with a total installed capacity of 46.3 MW. The compressors situated at the shafts are manned by compressor attendants.

One of the major constraints at Mine C is that two of the baseload compressors do not have capacity control capabilities. A further constraint is that mine management does not allow frequent stopping and starting of these two machines or the 15 MW compressor. The compressed air system was simplified to analyse different energy saving initiatives. The results from the analysis showed that a revised compressor operating schedule will result in reduced compressor power consumption. The analysis further indicated that the use of surface control valves would be a feasible option. The simulated saving for the combination of revised compressor control schedules and surface control valves is 2.6 MW.

The analysis proved that the saving could be increased to 5.2 MW if the compressor situated at the plant is also used as a top-up compressor. This compressor was however not in a reliable state. The additional savings as a result of the use of the compressor at the plant made it financially feasible to upgrade and repair the plant compressor for regular use. The plant compressor upgrades were however not finalised on completion of the study due to unforeseen problems and projects delays.

The average saving achieved for the first three months after project completion was 2.8 MW. The simulated saving for surface valve control and compressor control was 2.6 MW. The simulated results were therefore within 8% of the actual saving.

The integrated approach was also used to identify energy saving techniques at Mine D. The compressed air system at Mine D consists of twelve compressors connected to eight shafts via an extensive surface pipe network. Several surface areas such as workshops, pneumatic loading systems, and so forth are also supplied with compressed air from the surface compressed air piping systems. These connections require a constant pressure even though the shafts have a varying pressure requirement.

It was viable to install surface control valves at Mine D due to the varying pressure requirements of the shafts. The constant pressure requirements from the workshops, pneumatic loading systems and the training centre required a constant surface pressure. These constant pressure users were isolated from the compressed air ring through the installation of dedicated compressors and through a hydraulic conversion of the pneumatic loading boxes.

This allowed a decrease in the system pressure during non-peak production periods. The compressor control strategy was also improved to reduce compressed air supply. The project realised a saving of 5.7 MW compared to a simulated saving of 4.9 MW. The simulated results provided an estimated saving that was within 16% of the saving achieved.

The results from the projects implemented at four of the mines were discussed in detail in the previous sections. The integrated model was also used to analyse the compressed air systems of eighteen other mines. The results from all twenty-two mines were grouped into the three main steps of the integrated approach.

The energy consumption of two of the twenty-two compressed air systems were only improved according to the first step of the integrated approach. These projects reduced average compressor power consumption by 9 MW which is equivalent to an electricity cost saving of R14 million per annum.

Compressor power consumption at ten mines was reduced by 75 MW by using the first two steps of the integrated approach. This is equivalent to a saving of approximately R215 million per annum. All three steps of the integrated approach were used to improve compressor power consumption at ten other mines. The projects implemented at these mines resulted in an average compressor power reduction of 26 MW. This is equivalent to a yearly electricity cost saving of approximately R75 million per annum.

The combined saving of 109 MW is equivalent to an annual electrical energy reduction of 0.96 TWh. A combination of the ESCO funding model and a twelve month payback requirement from the mines could result in project funding to the value of R795 million. The implementation of the integrated approach could be applied to other industrial compressed air systems. The approach has the potential to reduce global electricity demand by 267 TWh. That is more than the total amount of electricity consumed in South Africa.