

Chapter 1: Introduction

According to the World Bank, South Africa is considered to be one of the advanced emerging economies of the world [1]. It is clear from Figure 1 that South Africa's energy demand, along with that of other advanced emerging economies, has been increasing steadily since 1972.

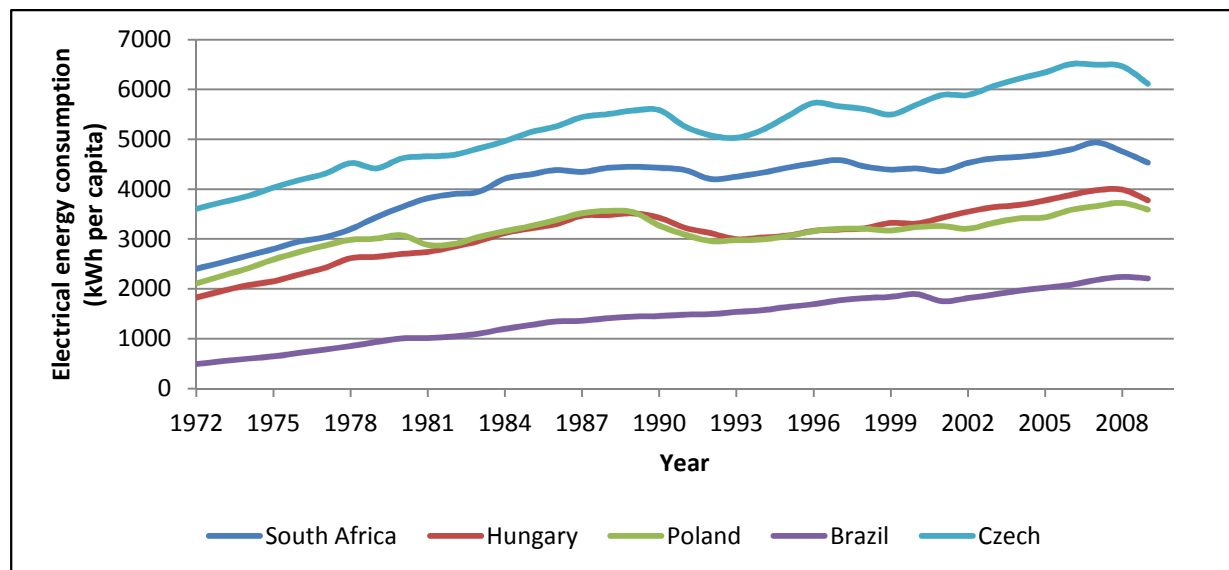

Figure 1: Electric power consumption per capita for emerging economies

As this demand for electricity increases, new sources of energy will have to be explored and existing energy users will have to become more energy efficient. Several electrical energy savings procedures have been proposed for the industry. In general, these procedures are referred to as demand-side management (DSM) and supply-side management (SSM).

The mining industry is one of the larger consumers of electrical energy. A significant percentage of this energy is consumed by electric motors that drive centrifugal air compressors. Each combination of electric motor and compressor may operate at different efficiencies, depending on the age and design. It is important that the most efficient compressor combination should be selected wherever possible.

Other factors that must be considered are pipe friction losses and leaks to ensure that the correct compressor selection is made. Effective compressor selection reduces operating costs [2, p. 178], [3, p. 92]. The dynamic compressor selector (DCS) will be shown to significantly reduce overall energy consumption at a platinum mine.

1.1 Context and background

Each shaft receives air from the compressed air network, commonly referred to as a compressed air ring. These compressed air networks consist of multiple compressor houses that contain one or more centrifugal compressors that vary in output capacity. Compressors are switched on and off according to the compressor priorities that are determined by the compressor control room operator, based on previous experience.

Shaft air pressures are taken from measuring points in the compressed air supply line at the entrance to each shaft and can be accessed by the shaft and compressor control room operators. Present procedures, even for experienced control room operators, make it difficult to react swiftly to a change in the system's compressed air demand. If, for example, a shaft requires an increase in pressure, the shaft's control room operator will telephone the compressor control room operator. Compressor priorities are then either changed to allow larger compressors to run or the pressure set point is increased. Depending on the distance of the compressor from the user end point, there will be a definite time lag before the pressure change is registered at the end point. The best priorities are not always followed when additional compressors are started.

Furthermore, the existing compressor controller at the mine only utilises pressures that can be measured at the compressor house manifold. This does not take the changes in pressures and flows at the shafts into account. When the air pressure at a shaft decreases, there is a small but significant delay before it is measured at the compressor house. This might cause two compressors to start up simultaneously

when the pressure drop is registered at the compressor house. If the pressure drop was only temporary, one of the compressors will be switched off again shortly afterwards.

It would therefore be beneficial if system pressure changes could be anticipated and control adjustments made accordingly. Ideally, a compressor should be started or stopped before the pressure changes are measured at the compressor house.

1.1.1 Compressed air network

The compressed air network consists of a system of steel pipes that connect the compressor houses to the shafts, workshops, concentrators and smelters. In this case study, low power stand-alone screw compressors were installed to supply the workshops, concentrators and smelters. These systems were therefore isolated and operated independently from the compressed air network. These compressed air users use high pressure at low flow. By isolating them from the compressed air network, the entire network pressure set point could be reduced. Because this was done before the implementation of the DCS project, these three compressed air consumers are not relevant to this study.

Compressor houses and compressors

Various operating capacity multistage compressors are used to generate compressed air. Ambient air is compressed and cooled by a water-cooled heat exchanger after passing through each compressor stage.

Figure 2 shows an example of a VK100 compressor. The VK100 normally delivers a flow of approximately 100 000 m³/h with a 10 MW installed motor. This particular compressor has a motor with a rating of 8.6 MW. The smaller motor restricts the flow to approximately 85 000 m³/h. The power consumption and delivery flow are measured for each compressor using permanently installed power and flow meters. The logged data is stored on a server at the mine.



Figure 2: VK100 compressor

Figure 3 shows the cooling tower of the heat exchangers.



Figure 3: Compressor cooling tower

The flow diagram in Figure 4 illustrates the interaction between different components of a centrifugal compressor at the mine.

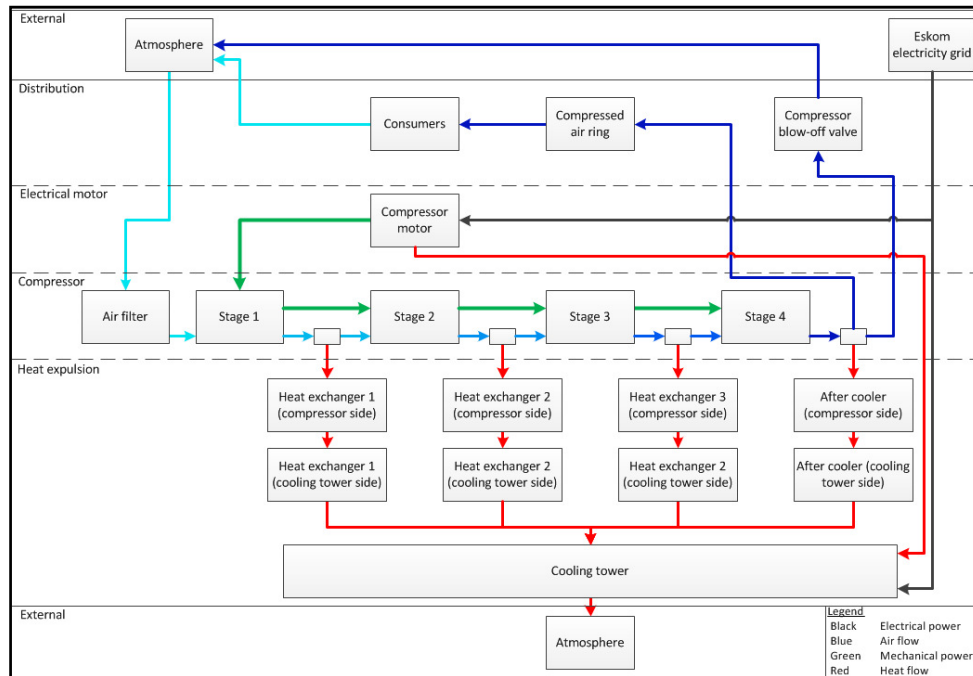

Figure 4: Flow diagram of a typical four-stage centrifugal compressor

After the compressed air is cooled through the last heat exchanger of the multistage compressor, it enters a common manifold from where it supplies the compressed air network.

Pressure set point control

The compressors on the compressed air network are controlled according to a pressure set point that is measured at the compressor house exit. This set point is an input from the compressor control room operator into the compressor master controller. When the compressor delivery pressure rises above a certain pressure threshold, inlet guide vanes will adjust automatically to reduce the inlet mass air flow [4, p. 175]. The compressor then supplies less air flow, at the required set point pressure, to the compressed air system. Because the mass flow is reduced, less power is consumed [4, p. 175]. Conversely, when the pressure drops below the pressure threshold, the inlet guide vanes adjust to allow the pressure to rise and air

flow to increase. Decreasing the guide vane angle reduces the efficiency of the compressor [5, p. 119].

Depending on the system pressure requirements that vary during the day, the compressor delivery pressure will be adjusted to operate at different set points.

Surge and blow-off

Surge is defined by Saravanamuttoo et al. as:

“...a sudden drop in delivery pressure, and with violent aerodynamic pulsation which is transmitted through the entire machine.” [4, p. 182]

A compressor may surge when operating at a fixed rotational speed and its flow is reduced to the point where it is no longer operating in a stable manner [6, p. 1 Ch 9],[7, p. 205]. A blow-off valve is one method that is commonly used to prevent surge. This ensures that the delivery pressure is lower than the pressure inside the last stage of the compressor. Air lost through the blow-off has no use and is generated unnecessarily [4, p. 487],[8, p. 142]. A well-balanced control system will minimise blow-off.

Supply lines of the compressed air network

Platinum group metals are extracted by the mine using pneumatic drills, loaders and other pneumatic equipment that are on the various mining levels. Various types of equipment require compressed air at different operational air pressures for optimum operation. The compressed air from the compressor houses is supplied to the shafts via pipelines of the compressed air network.

Figure 5 shows the compressed air network layout of the mine. The red and blue squares represent the shafts and compressor houses respectively. The pipeline is

shown in yellow. The combined surface pipe length¹ for this site is approximately 8.5 km.

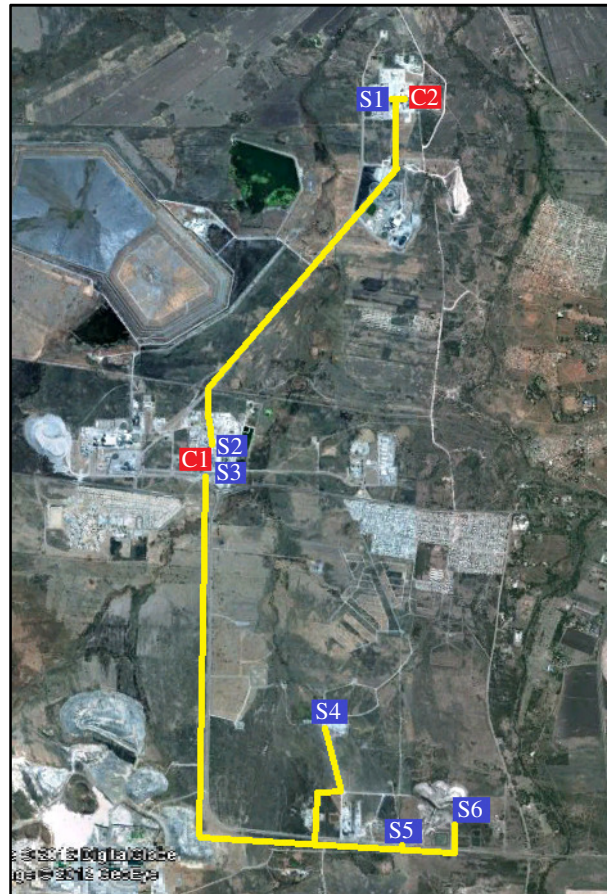

Figure 5: Mine layout

The pipeline is made up of many smaller pipe sections seen in Figure 6. For this particular site, these pipe sections are typically 6 m to 9 m in length and have diameters of between 350 mm and 600 mm.

¹ A mine that is considered for future DCS implementation has a combined surface length of 76 km.



Figure 6: Section of the pipeline

To prevent the pipes from buckling due to thermal expansion, expansion joints are used [9, p. 31],[10, p. 335], [11, p. 269]. These expansion joints contribute to line losses. Figure 7 shows a typical expansion joint.



Figure 7: Expansion joint

1.1.2 Existing compressor controller

The existing compressor master controller shown in Figure 8 is the interface between the control room operator and the compressors of the compressed air network. This compressor master controller was developed by Hiprom|Rockwell Automation² and the compressor control room operator monitors the master controller. Compressor priorities are given as input, based on previous experience. The compressor master controller starts and stops compressors according to the operator's priority and set point selection.

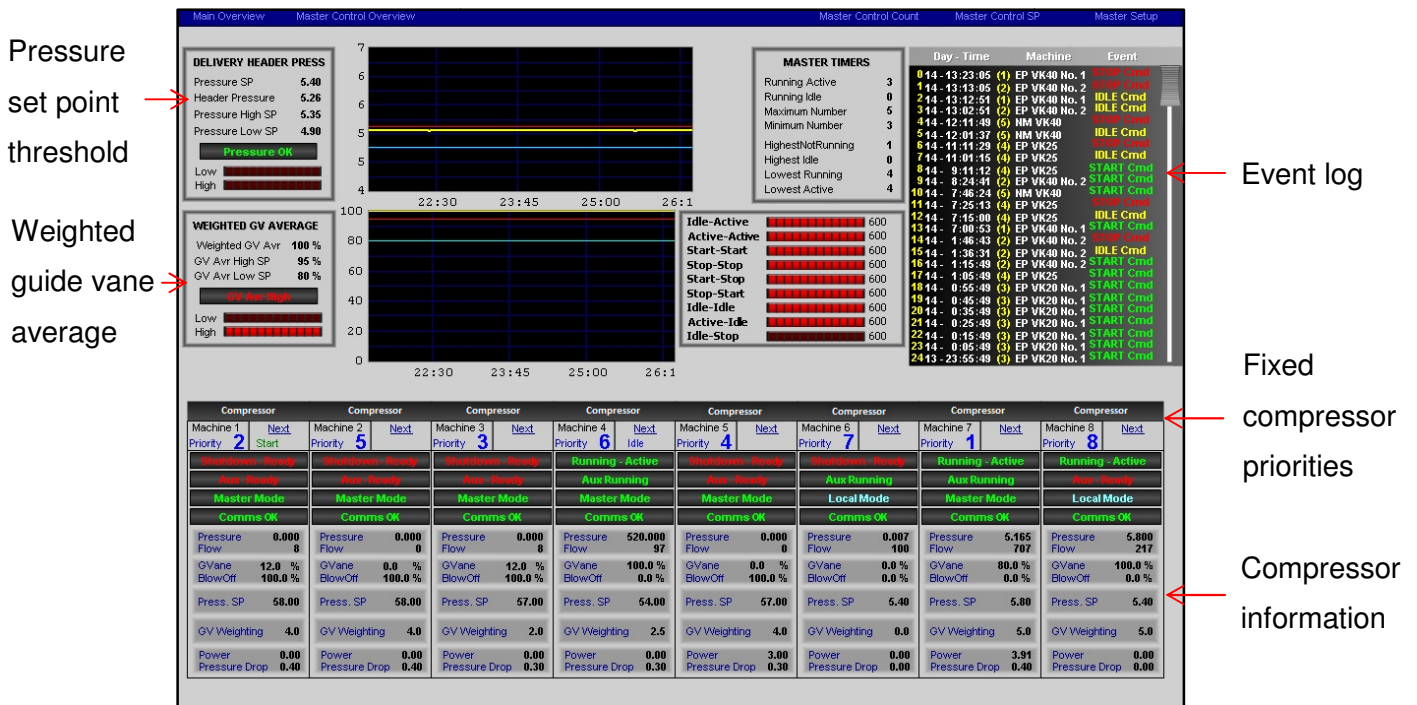

Figure 8: Screenshot of the existing master controller

² Compressor master controller developed by Hiprom | Rockwell Automation, <http://www.hiprom.com/>.

The interface screenshot of Figure 8 shows the pressure set point and threshold, an event log, the compressor priorities and other compressor information, such as the guide vane angle, blow-off valve position, exit pressure and operating compressors.

The screenshot also shows a weighted guide vane average window. This function was included in an attempt to improve compressor reaction to pressure changes.

Lower powered compressors will cut back first because of their smaller weighted guide vane average. This method of control was not successful and the mine stopped using it. The master controller's interface has not been updated to remove the window for the weighted guide vane average.

Pressure set points

Figure 9 shows what the pressure set point interface of the present compressor master controller looks like.

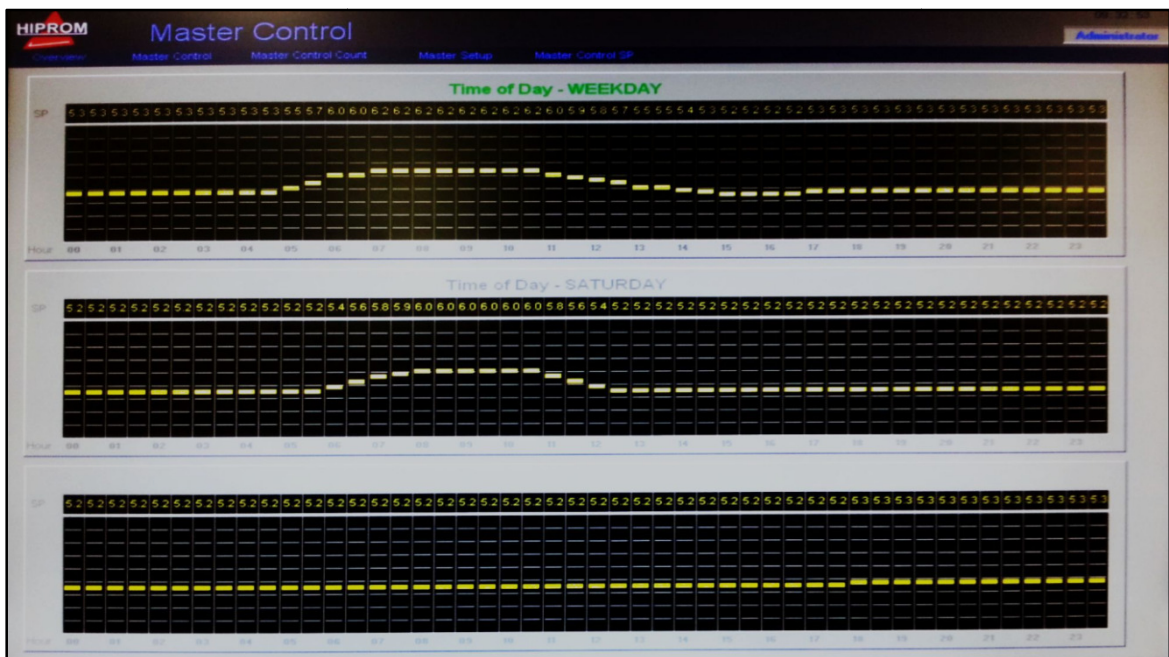

Figure 9: Compressor master controller pressure set point interface

The operator can adjust the compressor set points in 30-minute intervals.

A pressure set point is specified for all compressor programmable logic controllers (PLCs) on the compressed air network. Using feedback loops (illustrated in Figure 10), this set point pressure is maintained within a predetermined pressure range by the compressors' guide vanes.

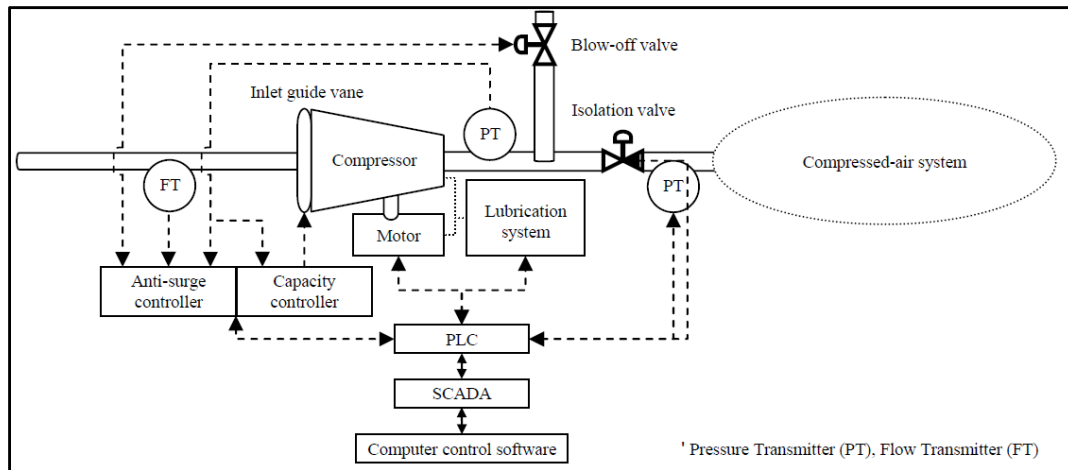

Figure 10: Compressor control feedback loop [12]

Guide vane control and compressor protection is done at PLC level. This protects the compressor against surge and auxiliary malfunction. The compressor master controller therefore cannot start a compressor if the cooling tower pump is malfunctioning, for example.

If the guide vane control cannot maintain the pressure set point within the prescribed limits, a compressor will be stopped or started, depending on the system requirements.

Compressor priorities

The compressor priorities determine which compressor will be stopped or started first. Figure 11 shows the accumulative compressor power consumption for a typical working weekday.

The compressors with the highest priorities are the base load compressors – numbered 1, 2 and 3 in Figure 11. These are the only compressors that operate continuously. During the drilling shift that starts at 07:00, the demand for compressed air increases.

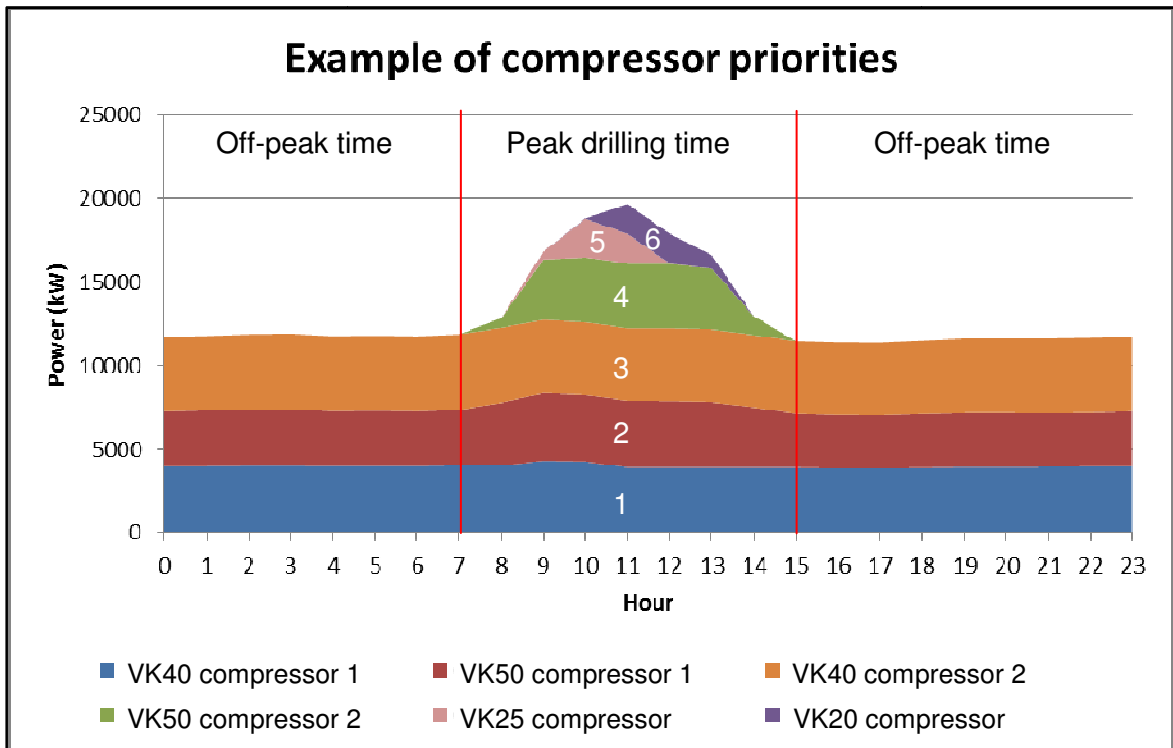

Figure 11: Example of compressor priorities at the mine

The three base load compressors can no longer supply the compressed air network with the required pressure and flow. At least one more compressor will be required. The compressor with the fourth highest priority will then be scheduled to come on line. This procedure is followed by assigning each successive compressor with the next lowest priority to come on line as the demand for compressed air increases.

When the demand for compressed air decreases, the process is reversed. The compressor with the lowest priority will shut down first, followed by the compressor with the next lowest priority or as the situation demands.

1.1.3 Existing demand-side management strategies

As part of the energy-saving initiatives, drilling staff are required to ensure that their compressed air pipe sections are properly closed off after the drilling shift. This procedure is not always followed and is difficult to monitor because of the size and underground distances of each shaft.

Automated control valves are often used to close off the compressed air to the level after the drilling shift. However, guidelines provided by the South African Department of Mineral Resources require there to be a positive downstream pressure to supply refuge bays with air in case of an underground emergency [13].

Not all levels complete drilling at the same time and in some instances require different minimum pressures. Installing control valves at each mining level allows the shaft to close the compressed air supply to each level when drilling at that level has been completed. This enables more accurate control of the compressed air distribution. However, many automated underground level control valves were repeatedly vandalised by mine workers. This makes this strategy difficult to maintain. There are also a large number of mining levels in a typical mine. This causes this strategy to be relatively expensive, as the valves must be continuously replaced.

An alternative to underground control valves is to install a surface control valve. The surface valve setup is relatively cheap and easy to maintain because it is more readily accessible. Pressure control of the entire compressed air column is possible, using a single valve, before splitting it off for use on the different mining levels. However, with a surface control valve, individual mining level pressure control is not possible.

A combination of surface and underground level control valves has the benefit of more precise control for individual mining levels, as well as being able to control the pressure of the main column. This is the most expensive option as both the mining level valves and a surface control valve need to be purchased and installed.

The site at which the DCS was to be implemented had already installed surface control valves instead of underground level control valves. Figure 12 shows an installed surface valve at one of the shafts on the mine.



Figure 12: Surface valve installation

During the drilling shift, both valves are fully open so that the maximum air flow at maximum pressure is delivered to the shaft. When all the drilling staff on all the levels have cleared their sections for blasting, the main line valve is closed. The air now flows through the bypass pipe section only. This valve is then modulated according to a set point on the downstream pressure using a proportional integral derivative (PID) control loop.

The pressure is not controlled on the main line valve because the larger valve would be controlling in the nearly fully closed position for reduced air flow requirements.

This results in a very high local air velocity that causes pitting and will wear out the valve seat.

1.2 Dynamic compressor selection to improve energy efficiency

In this dissertation, a DCS for an existing DSM tool – a real-time energy management system (REMS)³ – is developed for the mining industry. The DCS will calculate pipe friction flow losses between the compressor outlet and the points of production. This information, together with individual compressor performances, will be used to ensure the most efficient selection of compressors.

The optimum control of a compressed air system requires a clear modification of all the operational procedures and requirements.

1.3 Problem formulation

Compressor control is not presently performed in an energy-efficient manner and the mine is experiencing problems with compressor cycling. These problems, as well as other problems that arose with the development of the DCS, can be divided into the following subproblems:

1.3.1 Compressed air network solving

There are numerous network solving software packages to simulate compressed air networks. However, none of these packages can receive values as input or give output values from and to the REMS, respectively.

³ REMS developed by HVAC International, <http://www.hvacinternational.com/Technologies/>.

1.3.2 Compressor control

Compressors are unnecessarily started and stopped due to compressor priorities that are presently fixed.

1.3.3 Compressor control room operator

A compressor control room operator cannot do the complex fluid flow calculations to efficiently change the compressor priorities. The operator can also not monitor the system every moment of the day.

1.3.4 Communication network

The mine has strict network standards that need to be upheld for safety, production and maintenance reasons. Ideally, all control has to be done at the PLC level in case of network or supervisory control and data acquisition (SCADA) communication failure. However, it is not possible to program complex nonlinear fluid flow equations for PLC processing.

1.3.5 Quantifying pressure loss components

Assigning theoretical values to the pressure loss components of the compressed air network is not possible due to the size of the network and the number of pressure loss components.

1.4 Dissertation overview

Chapter 2 discusses the challenges and limitations of the mine's compressed air system and sets a user requirement. Chapter 3 covers the research and calculations that are required for the development of the DCS, and presents a solution for the DCS. Chapter 4 shows the results that were obtained from the DCS solution. Chapter 5 summarises the dissertation and gives suggestions for further research.