

**THE INVOLVEMENT OF NITRIC OXIDE IN A
RODENT MODEL OF POST-TRAUMATIC
STRESS DISORDER.**

Frasia Oosthuizen

B.Pharm., M.Sc. (Pharmacology)

Thesis submitted in fulfilment of the requirements for the degree

Philosophiae Doctor

*In the School of Pharmacy (Pharmacology) of the Potchefstroom University for
C.H.E.*

Promotor: Dr. L. Brand

Co-Promotor: Prof. B.H. Harvey

Potchefstroom
2003

TABLE OF CONTENTS

TABLE OF CONTENTS	I
LIST OF TABLES	VI
LIST OF FIGURES	VII
OPSOMMING	IX
ABSTRACT	XI
1. INTRODUCTION	1
1.1. Study aim and design.....	4
2. POST-TRAUMATIC STRESS DISORDER	5
2.1. Definition and Background.....	5
2.1.1. Epidemiology.....	5
2.1.2. Aetiology.....	6
2.1.3. Diagnosis.....	7
2.1.4. Clinical features.....	8
2.1.5. Course and prognosis.....	10
2.1.6. Treatment of PTSD.....	11
2.2. Pathophysiology.....	11
2.2.1. Detection of trauma.....	11
2.2.2. Memory deficits in PTSD.....	12
2.2.3. Processing of emotionally charged memories: The limbic system.....	14
2.2.3.1. Amygdala.....	14
2.2.3.2. Hippocampus.....	15
2.3. Neurochemistry of PTSD.....	16

2.3.1. Reduction in hippocampal volume: Glucocorticoids.....	16
2.3.2. Involvement of cytokines.....	18
2.3.3. Hippocampal damage: Glutamate and GABA.....	19
2.3.4. Involvement of other neurotransmitters.....	22
2.4. Pharmacotherapy.....	24
2.4.1. Prospectus.....	26
2.5. Animal models for studying PTSD.....	27
3. NITRIC OXIDE.....	31
3.1. Background on nitric oxide.....	31
3.1.1. Chemical reactions of nitric oxide.....	32
3.2. Stimulation of NO synthesis.....	34
3.2.1. Glutamate.....	34
3.2.2. NMDA receptor activation.....	35
3.2.2.1. The NMDA receptor and excitotoxicity.....	37
3.2.2.2. The NMDA receptor and long term potentiation.....	38
3.2.3. Nitric oxide synthase.....	40
3.3. Synthesis of Nitric Oxide.....	42
3.4. Physiological effects of nitric oxide.....	45
3.4.1. Nitric oxide as neurotransmitter.....	45
3.4.2. Nitric oxide and cGMP.....	46
3.4.3. Nitric oxide and the central nervous system.....	47
3.4.4. Diverse effects of nitric oxide.....	47
3.5. NO: Neurotoxicity vs. neuroprotection.....	49
3.5.1. NO's role in neuroprotection.....	49
3.5.1.1. The effect of nitric oxide on nitric oxide.....	49
3.5.1.2. The effect of nitric oxide on the NMDA receptor.....	50
3.5.1.3. Nitric oxide containing neurons.....	50
3.5.2. NO and neurotoxicity.....	50
3.5.2.1. Nitric oxide and peroxynitrite.....	51
3.5.2.2. Mechanisms of nitric oxide induced neurotoxicity.....	51
3.5.2.3. Additional explanations for NO-mediated energy depletion and cytotoxicity.....	53
3.6. Summary.....	54

4. EXPERIMENTAL DESIGN	55
4.1. Experimental conditions and treatment of rats.....	55
4.1.1. Animal model of PTSD.....	55
4.1.1.1 Validation of the TDS-model.....	57
4.1.1.1.1. Plasma corticosterone levels.....	57
4.1.2. Drug treatment.....	59
4.1.2.1. Fluoxetine.....	60
4.1.2.2. Aminoguanidine.....	60
4.1.2.3. 7-Nitroindazole.....	60
4.1.2.4. Ketoconazole.....	62
4.1.3. Tissue dissection and storage.....	62
4.1.4. Determination of protein concentration.....	62
4.2. Analysis of NOS-activity.....	64
4.2.1. Characterization and development of assay method.....	64
4.2.1.1. Isolating the enzyme.....	64
4.2.1.2. Enzyme concentration.....	65
4.2.1.3. pH.....	66
4.2.1.4. Temperature.....	67
4.2.1.5. Presence of co-factors.....	67
4.2.1.6. Substrate concentration.....	67
4.2.2. Assay.....	68
4.2.3. Analysis of data.....	70
4.3. NMDA receptor density.....	73
4.3.1. Preparation of brain homogenate.....	73
4.3.2. Assay.....	74
4.3.3. Measuring of radioactivity.....	75
4.4. HPLC Analysis of GABA.....	75
4.4.1. Validation of method.....	75
4.4.2. Mobile phase.....	75
4.4.3. Experimental conditions.....	75
4.4.4. Calibration solutions.....	76
4.4.5. Sample preparation.....	76
4.4.6. Sample injection.....	77
4.5. Statistical analysis.....	78

5. EXPERIMENTAL RESULTS	79
5.1. Validation of the TDS-model.....	79
5.1.1. Plasma corticosterone levels.....	79
5.2. Control vs. Experimental values.....	81
5.2.1. NOS activity.....	82
5.2.1.1. NOS Vmax.....	82
5.2.1.2. NOS Km.....	83
5.2.2. NMDA receptor characteristics.....	84
5.2.2.1. NMDA Bmax.....	84
5.2.2.2. NMDA Kd.....	85
5.2.3. GABA levels.....	86
5.3. Drug treatment.....	87
5.3.1. Fluoxetine.....	88
5.3.1.1. NOS activity.....	88
5.3.1.1.1. NOS Vmax.....	88
5.3.1.1.2. NOS Km.....	90
5.3.1.2. NMDA receptor characteristics.....	91
5.3.1.2.1. NMDA Bmax.....	91
5.3.1.2.2. NMDA Kd.....	92
5.3.2. Aminoguanidine.....	93
5.3.2.1. NOS activity.....	93
5.3.2.1.1. NOS Vmax.....	93
5.3.2.1.2. NOS Km.....	94
5.3.2.2. NMDA receptor characteristics.....	95
5.3.2.2.1. NMDA Bmax.....	95
5.3.2.2.2. NMDA Kd.....	96
5.3.3. 7-Nitroindazole.....	97
5.3.3.1. NOS activity.....	97
5.3.3.1.1. NOS Vmax.....	97
5.3.3.1.2. NOS Km.....	98
5.3.3.2. NMDA receptor characteristics.....	99
5.3.3.2.1. NMDA Bmax.....	99
5.3.3.2.2. NMDA Kd.....	100
5.3.4. Ketoconazole.....	101

5.3.4.1. NOS activity.....	101
5.3.4.1.1. NOS Vmax.....	101
5.3.4.1.2. NOS Km.....	102
5.3.4.2. NMDA receptor characteristics.....	103
5.3.4.1.1. NMDA Bmax.....	103
5.3.4.1.2. NMDA Kd.....	104
5.3.4.3. Plasma corticosterone levels.....	105
5.4. Summary of results.....	107
5.4.1. Summary of NOS parameters.....	107
5.4.2. Summary of NMDA receptor parameters.....	108
6. DISCUSSION.....	109
6.1. Glucocorticoids in PTSD.....	109
6.2. The glutaminergic–NMDA pathway in PTSD.....	112
6.2.1. NMDA receptor density in PTSD.....	113
6.3. NO in PTSD.....	114
6.4. GABA in PTSD.....	116
6.5. Effects of pharmacological intervention on NO	118
6.5.1. Fluoxetine.....	119
6.5.2. 7-Nitroindazole.....	121
6.5.3. Aminoguanidine.....	124
6.5.4. Ketoconazole.....	127
7. CONCLUSION.....	129
7.1. Summary and conclusion of results.....	129
7.2. Conclusion.....	130
7.3. Future studies.....	131
7.4. Presentations.....	131
BIBLIOGRAPHY.....	132
ACKNOWLEDGEMENTS.....	153

LIST OF TABLES

CHAPTER 2: LITERATURE REVIEW

Table 2-1 Drugs used in the treatment of PTSD.....	25
---	----

CHAPTER 4: EXPERIMENTAL DESIGN

Table 4-1 Radioimmunoassay for determination of plasma corticosterone.....	58
---	----

Table 4-2 Reagent cocktail for NOS-assay.....	69
--	----

CHAPTER 5: EXPERIMENTAL RESULTS

Table 5-1 Summary of Vmax and Km values for NOS.....	107
---	-----

Table 5-2 Summary of Bmax and Kd values for NMDA receptors.....	108
--	-----

LIST OF FIGURES

CHAPTER 2: POST-TRAUMATIC STRESS DISORDER

Figure 2-1 Detection modalities and psychobiological modulators in stress response.....	12
Figure 2-2 Schematic presentation of the limbic system.....	14
Figure 2-3 Mechanism of cytokine-induced neurotoxicity.....	19
Figure 2-4 Mechanism of GABA / glutamate pathways in memory formation.....	23

CHAPTER 3: NITRIC OXIDE

Figure 3-1 Chemical reactions of NO with O ₂	33
Figure 3-2 Chemical reactions of NO with O ₂ ⁻	33
Figure 3-3 Chemical reactions of NO with iron and thiol.....	34
Figure 3-4 NMDA-receptor ionophore complex.....	36
Figure 3-5 Enzymatic structure of NOS.....	40
Figure 3-6 Synthesis of NO.....	42
Figure 3-7 Substrate binding site of NO.....	42
Figure 3-8 Electron transfer in NO-synthesis.....	43
Figure 3-9 Model for the action of the NO-system in the CNS.....	44
Figure 3-10 Mechanism of NO-mediated neurotoxicity.....	52

CHAPTER 4: EXPERIMENTAL DESIGN

Figure 4-1 Isolation of the NOS-enzyme.....	65
Figure 4-2 Determination of protein concentration.....	65
Figure 4-3 Linweaver-Burke plot.....	72

CHAPTER 5: EXPERIMENTAL RESULTS

Figure 5-1 Plasma corticosterone levels.....	80
Figure 5-2 NOS Vmax values.....	82
Figure 5-3 NOS Km values.....	83
Figure 5-4 NMDA Bmax values.....	84
Figure 5-5 NMDA Kd values.....	85
Figure 5-6 GABA values.....	86
Figure 5-7 NOS Vmax values for fluoxetine pre-treatment.....	88
Figure 5-8 NOS Km values for fluoxetine pre-treatment.....	90
Figure 5-9 NMDA Bmax values for fluoxetine pre-treatment.....	91
Figure 5-10 NMDA Kd values for fluoxetine pre-treatment.....	92
Figure 5-11 NOS Vmax values for aminoguanidine pre-treatment.....	93
Figure 5-12 NOS Km values for aminoguanidine pre-treatment.....	94
Figure 5-13 NMDA Bmax values for aminoguanidine pre-treatment.....	95
Figure 5-14 NMDA Kd values for aminoguanidine pre-treatment.....	96
Figure 5-15 NOS Vmax values for 7-nitroindazole pre-treatment.....	97
Figure 5-16 NOS Km values for 7-nitroindazole pre-treatment.....	98
Figure 5-17 NMDA Bmax values for 7-nitroindazole pre-treatment.....	99
Figure 5-18 NMDA Kd values for 7-nitroindazole pre-treatment.....	100
Figure 5-19 NOS Vmax values for ketoconazole pre-treatment.....	101
Figure 5-20 NOS Km values for ketoconazole pre-treatment.....	102
Figure 5-21 NMDA Bmax values for ketoconazole pre-treatment.....	103
Figure 5-22 NMDA Kd values for ketoconazole pre-treatment.....	104
Figure 5-23 Plasma corticosterone levels for ketoconazole pre-treatment.....	105

OPSOMMING

Post-traumatische stress sındroom is 'n angsttoestand wat ontwikkel na blootstelling aan 'n traumatiese gebeurtenis. 'n Verkleining van die hippokampus word geassosieer met wanfunksies van geheue, insluitend amnesie en gedagtesteuimisse, wat kenmerkend is van die sındroom. Alhoewel die akute verhoging in plasmavlakke van glukokortikoïede, na blootstelling aan stress, 'n rol speel in die verkleining van die hippokampus, word post-traumatische stress sındroom gekenmerk deur 'n verlagıng in glukokortikoïedvlakke. Dit wil dus voorkom asof glukokortikoïede 'n proses, wat resulteer in selfskade en 'n verkleinde hippokampus, aktiveer, maar nie alleen hierdie veranderinge teweeg bring nie.

Uit die literatuur is dit duidelik dat nie net glukokortikoïede en die eksitatoriese aminosuur, glutamaat, betroke is in die prosesse van neurotoksisiteit wat tot 'n verkleining in die volume van die hippokampus lei nie, maar dat stikstofoksied ook 'n belangrike rol speel.

In hierdie studie is die langtermynveranderinge in plasma kortikosteroönvlakke, die aktiviteit van stikstofoksiedsintetase, NMDA-reseptordigtheid, en GABA-vlakke in die hippokampus van proefdiere bepaal. 'n Proefdiemodel, wat berus op tydsafhanklike sensitisasie na blootstelling aan stressors, is gebruik om simptome, soortgelyk aan post-traumatische stress sındroom, in rotte te induseer. Hierdie model berus op blootstelling van die diere aan 'n reeks van drie akute stressors. Na 'n week word die rotte weer blootgestel aan een van die oorspronklike stressors, wat dien as herinnering aan die oorspronklike trauma. Blootstelling aan die proefdiemodel resulteer in biochemiese en hormonale veranderinge wat nie deur tyd beïnvloed word nie, soortgelyk aan die simptome van post-traumatische stress sındroom wat konstant bly, of vererger met verloop van tyd.

Die resultate van hierdie studie het getoon dat blootstelling van proefdiere aan akute stressors die afskeiding van kortikosteroön verhoog. Op die langtermyn

het die afskeiding van kortikosteroon egter gedaal tot vlakke onder normaalwaardes. Dit impliseer dus dat, alhoewel glukokortikoïede in selskade in die hippokampus betrokke is, verhoogde glukokortikoïedvlakke nie die enigste meganisme is vir die skade aan die hippokampus en meegaande geheuesturnisse, soos waargeneem in post-traumatiese stress sindroom nie.

Die blootstelling van rotte aan bg. proefdiermodel het die aktiwiteit van stikstofoksiedsintetase verhoog, met 'n meegaande verlaging in NMDA-reseptordigtheid en GABA-vlakke in die hippokampus.

In 'n tweede deel van die studie is gepoog om deur middel van farmakologiese intervensie, hierdie waargenome biochemiese veranderinge, na blootstelling aan die proefdiermodel, te inhibeer. Behandeling van proefdiere met fluoksetien, huidiglik aangedui in die behandeling van post-traumatiese stress sindroom, en 7-nitroindasool, 'n inhibeerder van neuronale stikstofoksiedsintetase, het geen effek op die verhoging in stikstofoksiedsintetase aktiwiteit teweeg gebring nie. Behandeling met aminoguanidien, 'n inhibeerder van induseerbare stikstofoksiedsintetase, het egter die aktiwiteit van stikstofoksiedsintetase verlaag, wat impliseer dat die verhoging in ensiemaktiwiteit, na blootstelling aan die dieremodel, waarskynlik a.g.v. verhoogde aktivering van die induseerbare vorm van stikstofoksiedsintetase is. Behandeling van proefdiere met ketokonasool, 'n inhibeerder van glukokortikoïedsintese, het 'n soortgelyke afname in die aktiwiteit van stikstofoksiedsintetase veroorsaak.

Hierdie studie het dus gevind dat simptome van post-traumatiese stress sindroom, soos geïnduseer d.m.v. 'n proefdiermodel, geassosiëer word met uitgesproke effekte in die stikstofoksied-sisteem en dat dit 'n bydraende faktor is in die etiologie van die siektetoestand.

Kernwoorde: post-traumatiese stress sindroom, hippokampus, stikstofoksiedsintetase, fluoksetien, 7-nitroindasool, aminoguanidien, ketokonasool, glukokortikoïede, GABA, NMDA-reseptore

ABSTRACT

Post-traumatic stress disorder (PTSD), an anxiety disorder, may develop after experiencing or witnessing a severe traumatic event. Characteristic symptoms include hyperarousal and amnesic symptoms, while volume reductions in the hippocampus of these patients appear correlated with illness severity and the degree of cognitive deficit. Stress-induced increases in plasma cortisol have been implicated in this apparent atrophy of the hippocampus, although, clinical studies have described a marked suppression of plasma cortisol in PTSD. Given this hypocortisolemia, the basis for hippocampal neurodegeneration and cognitive decline remains unclear.

While stress-related hippocampal structural changes have been linked to the neurotoxic effects of glucocorticoids and glutamate, NMDA-NO pathways have been found to play a causal role in anxiety-related behaviors.

Prior exposure to trauma is an important risk factor for PTSD. In most instances the disorder becomes progressively worse over time, possibly with a delayed onset, suggesting a role for sensitization. In this study a time-dependent sensitization (TDS) model was used to induce PTSD-like sequelae in male Sprague-Dawley rats. The TDS-model is based on exposure to acute stressors, with a reminder of the trauma, in the form of re-exposure to one of the acute stressors, seven days later. NOS-activity, NMDA receptor parameters (B_{max} and K_d) and GABA levels in the hippocampus of rats, as well as plasma corticosterone levels were determined 21 days after exposure to the TDS-model.

Increased levels of corticosterone were measured after exposure to acute stress, but these levels were found to decrease below basal levels 21 days after the re-exposure, thus mimicking glucocorticoid levels in patients with PTSD. These findings may also imply that the increase in glucocorticoid levels after stress

exposure is only the initial step in a cascade of events leading to neuronal damage in the hippocampus.

This study also found that stress-restress evoked a long-lasting increase in hippocampal NOS activity that was accompanied by a reactive down-regulation of hippocampal NMDA receptors and dysregulation of inhibitory GABA pathways. Subsequently, animals were chronically treated with certain pharmacological agents prior to exposure to the TDS-model to determine possible approaches for inhibiting the induction of PTSD. Pre-treatment with fluoxetine, currently indicated in the treatment of PTSD, and the nNOS inhibitor, 7-nitroindazole, had no effect on the increased NOS activity measured 21 days after exposure to the TDS-model. Pre-treatment with the iNOS inhibitor, aminoguanidine, however, resulted in inhibition of the observed increase in hippocampal NOS-activity, implicating a possible role for the iNOS isoform in the etiology of PTSD.

Treatment with ketoconazole, an inhibitor of glucocorticoid synthesis, resulted in inhibition of the increase in NOS-activity observed after exposure to TDS-stress, thus indicating a possible link between stress glucocorticoid-release and NO synthesis.

These perturbations may have importance in explaining the increasing evidence for stress-related hippocampal degenerative pathology and cognitive deficits seen in patients with PTSD. Uncovering and understanding the role of NO in PTSD will hopefully lead to the development of selective therapeutic agents in disorders like PTSD, as well as providing a better understanding of basic processes underlying normal and pathological neuronal functions in PTSD.

Key words: post-traumatic stress disorder; hippocampal damage; fluoxetine, NOS-activity, 7-nitroindazole; aminoguanidine; ketoconazole; glucocorticoids; GABA; NMDA receptors

1. INTRODUCTION

The Diagnostic and Statistical Manual of Psychiatric Disorders (DSM IV) classifies post-traumatic stress disorder (PTSD) as an anxiety disorder (APA, 1994).

Certain people, when exposed to horrific events, continue to reexperience these events in the form of nightmares, flashbacks, and intrusive thoughts, classic symptoms of PTSD. Others, exposed to similarly disturbing events, exhibit time-limited distress, subsequently recalling these experiences in relative tranquillity. Patients diagnosed with PTSD exhibit persistent involuntarily reliving of bygone events, implying dysfunctions in memory mechanisms. PTSD is thus primarily a disorder of memory (McNally, 1998).

The limbic system is that part of the central nervous system reported to maintain and guide the emotions and behaviour necessary for self-preservation and survival. Two particular areas of the brain have been implicated in the processing of emotionally charged memories: the amygdala and the hippocampus (Bremner, 1999; Bremner *et al.*, 1999; Davidson *et al.*, 1999; Elzinga & Bremner, 2002; McEwan *et al.*, 1997; NCPTSD, 2000; Sapolsky, 1996; Uno *et al.*, 1989; van der Kolk, 1994).

The hippocampus has been hypothesized to play a role in the binding of individual memory elements at the time of memory formation (Bremner 1999; Elzinga & Bremner, 2002). A dysfunctional hippocampus may thus represent the anatomic basis of the fragmentation of memory often seen in patients with PTSD. Recent studies have confirmed hippocampal volume reduction in PTSD. These studies also show that hippocampal volume reduction is specific

to PTSD and not associated with disorders such as anxiety or panic disorders (Elzinga & Bremner, 2002).

Stress has been found to result in the secretion of large amounts of glucocorticoids. The hippocampus is involved in the regulation of glucocorticoid release through inhibitory effects on the hypothalamic-pituitary-adrenal (HPA) axis and increased glucocorticoid levels play an important role in hippocampal damage. Glucocorticoids also directly affect memory function (Bremner, 1999).

If stress and subsequent PTSD results in hippocampal damage and associated problems with memory, this could have far reaching implications especially since the hippocampus plays an important role in new learning and memory formation (Bodnoff *et al*, 1995; Bremner, 1999; Elzinga & Bremner, 2002; Luine *et al*, 1994).

The question arises, if stress can damage the brain, is there anything that can be done to prevent this effect?

Given the relatively successful management of PTSD with selective serotonin re-uptake inhibitors (SSRI's), clinical and experimental PTSD research has focused on serotonin dysfunction and pharmacological manipulation of serotonin (van der Kolk, 1995). Selective serotonin re-uptake inhibitors however, remain only partially effective and there are no other adequately effective pharmacological interventions for PTSD (Harvey, 1996). While the involvement of the various catechol- and indole-amine neurotransmitters, noradrenaline, dopamine and serotonin in PTSD is unquestioned, there is now significant evidence to support the role of the amino acid transmitters, γ -amino butyrate (GABA) and glutamate, in the aetiology and pathology of affective illness (Harvey, 1996).

An important finding regarding antidepressants is that all currently marketed antidepressant classes, including the SSRI's, modulate the N-methyl-D-aspartate (NMDA) class of glutamate receptors, and there are preclinical and clinical results that suggests that glutamatergic NMDA receptor antagonists function as antidepressants and anxiolytics (Skolnick, 1999). Evidence suggests that glutamate may represent the ultimate pathway by which all presently used antidepressants mediate their psycho-modulatory action. It has been proposed that this excitatory amino acid has a primary role in treatment resistance and recurrence of affective illness, and it may determine long-term prognosis of the illness (Dawson & Dawson, 1996; Harvey, 1996; van der Kolk, 1994).

The principal sub-cellular effector molecules induced by the glutamate activation of the NMDA receptor class, is the promotion of calcium influx through the NMDA-gated ion channel, as well as the release of intracellular calcium from the sarcoplasmic reticulum (Southam & Gartwaite, 1996). This rise in cell calcium results in activation of a number of key calcium- and calmodulin-dependant enzymes, including nitric oxide synthase (NOS), proteases, lipases and protein kinases. These enzymes are capable of generating toxic oxidative intermediates that cause neuronal injury (Gartwaite, 1991).

An increase in extracellular glutamate levels in the various limbic brain areas is the result of stress exposure (Nutt, 2000). The extreme neurotoxic potential of glutamate is now well recognised in Alzheimer's disease, schizophrenia and affective illnesses. One of the cardinal symptoms of Alzheimer's disease is cognitive impairment and loss of mnemonic function, and has its origin in excessive glutamate activity (Dawson & Dawson, 1996; Harvey, 1996; Nutt, 2000). PTSD, similarly, is characterised by a loss of cognitive abilities. There is also evidence that, similar to the cortical volume loss seen in schizophrenics, the hippocampus of PTSD patients is smaller (McNally, 1998; Nutt, 2000; Sapolsky, 2000b). Although glutamate neurotransmission historically has been overlooked in the treatment of mood and anxiety disorders, it may nevertheless represent an area of major therapeutic opportunity.

1.1. STUDY AIM AND DESIGN

The aim of this study was to evaluate the possible molecular basis for the biochemical changes in an animal model of PTSD. A time-dependant sensitisation (TDS) model (Liberzon *et al*, 1997) was used to induce PTSD-like symptoms in Spraque-Dawley rats, based on the fact that prior exposure to trauma is an important risk factor for PTSD, and in most instances the disorder becomes progressively worse over time, possibly with a delayed onset (Bremner *et al*, 1999). Following the application of this stress model, we investigated the long-term effects of stress, or time-dependant sensitisation (TDS), on critical markers of nitric oxide, NMDA receptors and GABA in the hippocampus, in order to determine possible involvement in the etiology of PTSD.

In the second phase of this study certain drugs were evaluated with regard to their ability to modify the biochemical changes in response to the applied stress paradigm. These drugs included fluoxetine, currently used in the treatment of PTSD, ketoconazole, known for its inhibitory effects on glucocorticoids, as well as NOS-inhibitors.

Uncovering and understanding the properties of NO in PTSD will hopefully lead to the development of selective therapeutic agents in diseases like PTSD, as well as to a better understanding of basic processes underlying normal and pathological neuronal functions in PTSD.

2. POST-TRAUMATIC STRESS DISORDER

For some life lasts a short while, but the memories it holds lasts forever.

-Laura Swenson

2.1. DEFINITION AND BACKGROUND

PTSD is an anxiety disorder involving both somatic and psychological symptoms, and occurs in response to severe trauma (van der Kolk, 1994).

Clinical classification of PTSD requires the experience of an emotional stress of a high traumatic magnitude. PTSD consists of:

- the **reexperiencing** of the trauma through dreams and waking thoughts,
- persistent **avoidance** of reminders of the trauma and **numbing** of responsiveness to such reminders, and
- persistent **hyperarousal** (Kaplan et al, 1994).

Common associated symptoms of PTSD are depression, anxiety, and cognitive difficulties. The minimum duration of symptoms of PTSD is one month (Kaplan et al, 1994).

2.1.1. EPIDEMIOLOGY

The prevalence of PTSD in general population surveys in Western societies is estimated to be as high as 15% in a lifetime and 6% in a year (Kessler, 2000). Longitudinal research has shown that PTSD may become a chronic psychiatric disorder that may persist for decades and sometimes for a lifetime (Friedman, 1997).

The conditional risk of PTSD among trauma victims varies greatly depending on the type of trauma. Risk of PTSD is much greater after exposure to trauma

involving assault violence than after other forms of trauma. Duration of the trauma exposure is also a significant predictor of PTSD (Kessler, 2000).

2.1.2. AETIOLOGY

Experiencing, witnessing, or being confronted with an event involving serious injury, death, or threat to the physical integrity of an individual, along with a response involving helplessness, and/or intense fear or horror, causes PTSD. The more severe the trauma and the more intense the acute stress symptoms, the higher the risk for development of PTSD (Gore & Richards, 2002).

Although the stressor is necessary, it is not sufficient to cause the disorder. Individual preexisting biological factors, preexisting psychosocial factors, and events subsequent to the trauma, must also be considered. Even when faced with overwhelming trauma, the majority of people do not experience PTSD symptoms. Similarly, events that may appear mundane or less than catastrophic to most people may produce PTSD in some persons because of the subjective meaning of the event (Kaplan *et al*, 1994).

Persons most likely to develop PTSD include (Kaplan *et al*, 1994; NCPTSD, 2000):

- Those who experience greater stressor magnitude and intensity, unpredictability, uncontrollability, sexual (as opposed to nonsexual) victimization, real or perceived responsibility, and betrayal.
- Those with prior vulnerability factors such as genetics, early age of onset and longer-lasting childhood trauma, lack of functional and social support, and concurrent stressful life events.
- Those who report greater perceived threat or danger, suffering or being upset, terror, and horror or fear.
- Those within a social environment which produces shame guilt, stigmatization, or self-hatred.
- The presence of childhood trauma.
- Those with borderline, paranoid, dependant, or antisocial personality disorder traits.
- Recent excessive alcohol intake.

The magnitude of exposure, prior trauma, and social support, appear to be the three most significant predictors for developing chronic PTSD (van der Kolk, 1994).

The course of chronic PTSD usually involves periods of symptom increase followed by remission or decrease, although for some individuals symptoms may be unremitting and severe (NCPTSD, 2000).

2.1.3. DIAGNOSIS

The best way to diagnose PTSD is to combine findings from structured interviews and questionnaires with physiological assessments (NCPTSD, 2000). The information elicited from the interview with the patient must satisfy certain diagnostic criteria to make the formal diagnosis. The mental status examination should routinely consist of questions about exposure to trauma or abuse (Gore & Richards, 2002).

The first criterion for PTSD (Kaplan *et al*, 1994) has the following 2 components:

- **Experiencing**, witnessing, or being confronted with an event involving serious injury, death, or a threat to a person's physical integrity.
- A response involving helplessness, intense fear or horror.

The second major criterion (Kaplan *et al*, 1994) involves the persistent **re-experiencing** of the event in one of several ways. This may involve thoughts or perception, images, dreams, illusions, hallucinations, dissociative flashback episodes, or intense psychological distress or reactivity to cues that symbolize some aspect of the event.

The third diagnostic criterion (Kaplan *et al*, 1994) involves **avoidance** of stimuli that are associated with the trauma and numbing of general responsiveness; this is determined by the presence of 3 or more of the following:

- Avoidance of thoughts, feelings, or conversations that is associated with the event.
- Avoidance of people, places, or activities that may trigger recollections of the event.
- Inability to recall important aspects of the event.
- Significantly diminished interest or participation in important activities.
- Feeling of detachment from others.

- Narrowed range of affect.
- A sense of having a diminished future.

Symptoms of **hyperarousal** may be present where 2 or more of the following symptoms are required to fulfill this criterion (Kaplan *et al*, 1994):

- Difficulty in sleeping or falling asleep.
- Decreased concentration.
- Hypervigilance.
- Outbursts of anger or irritable moods / mood swings.
- An exaggerated startle response.

The duration of the relevant criteria symptoms should be more than 1 month, as opposed to acute stress disorder, which has duration of less than 1 month (Gore & Richards, 2002). PTSD may not develop until months or years after the event (Kaplan *et al*, 1994).

2.1.4. CLINICAL FEATURES

The principal clinical features of PTSD are the painful reexperiencing of the event, a pattern of avoidance and emotional numbing, and fairly constant hyperarousal (Kaplan *et al*, 1994). The trauma response is bimodal: hypermnesia, hyper-reactivity to stimuli, and traumatic re-experiencing coexist with psychic numbing, avoidance, amnesia and anhedonia. Whatever the source of the problem, some people with PTSD repeatedly relive the trauma in the form of nightmares and disturbing recollections. They may also experience sleep problems, depression, feeling detached or numb, or being easily startled. They may lose interest in things they previously enjoyed and have difficulty in exhibiting affection. They may feel irritable, be more aggressive or more violent than they were previously (van der Kolk, 1994).

Patients with chronic PTSD may present with somatic complaints and, possibly, general medical conditions (van der Kolk, 1994).

Mental status examination (Kaplan *et al*, 1994; Gore & Richards, 2000):

- General appearance may be affected. Patients may appear disheveled and have poor personal hygiene.
- Behavior may be altered. Patients may appear agitated and their startle reaction may be extreme.
- Orientation is sometimes affected. The patient may report episodes of not knowing the current place or time.
- Poor concentration.
- Poor impulse control.
- Altered speech rate and flow.
- Mood and affect may be changed. Patients may have feelings of depression, anxiety, guilt and/or fear.
- Thoughts and perception may be affected. Patients may be more concerned with the content of hallucinations, delusions, suicidal tendencies, phobias, and reliving the experience, and certain patients may become homicidal.
- Cognitive testing may reveal the patient has impairment of memory and attention.
- The mental status examination often reveals feelings of guilt, rejection, and humiliation.

The symptoms of PTSD are described via the following models (Kaplan *et al*, 1994):

The **cognitive model** of PTSD postulates that affected persons are unable to process or rationalize the trauma that precipitated the disorder. They continue to **experience** the stress and attempt to **avoid** the re-experiencing of the stress by avoidance techniques. Thus in trying to process the amount of information that the trauma provoked, the brain is alternating between periods of acknowledging the event and blocking them. Consistent with their partial ability to cope cognitively with the event, the patients experience alternating periods of acknowledging the event and blocking it.

The **behavioral model** of PTSD indicates that the disorder has two phases in its development. First the trauma (unconditioned stimulus) is paired, through classical conditioning, with a **conditioned stimulus** (physical or mental reminders of the

trauma). Second, through instrumental learning, the patient develops **a pattern of avoidance** of both the conditioned stimulus and the unconditioned stimulus.

The **psycho-analytic model** of the disorder hypothesizes that the trauma has reactivated a previously quiescent yet **unresolved psychological conflict**. The revival of the childhood trauma results in **regression** and the use of defence mechanisms or repression, denial and undoing.

Physical symptoms in acute PTSD include flexor changes in posture, hyperkinesias, "violently propulsive gait", tremor at rest, mask-like faces, cogwheel rigidity, gastric distress, urinary incontinence, mutism and a violent startle reflex. Similarity exists between many of these symptoms and those of diseases of the extrapyramidal motor system (van der Kolk, 1997).

2.1.5. COURSE AND PROGNOSIS

The course of PTSD usually has periods of symptom exacerbation and remission or decrease, although for some individuals symptoms may persist at an unremitting, severe level (NCPTSD, 2000).

People with PTSD have fairly good psycho-social adjustment. However, they do not respond to stress the way other people do. Under pressure they may feel or act as though traumatized all over again. High states of arousal seem to selectively promote retrieval of traumatic memories, sensory information, or behaviours associated with prior traumatic experiences (van der Kolk, 1997).

To compensate for chronic hyperarousal, traumatized people appear to shut down, on a behavioral level by avoiding stimuli reminiscent of the trauma, and on a psychobiological level by emotional numbing which extends to both trauma-related and everyday experiences (van der Kolk, 1997).

People with chronic PTSD tend to suffer from numbing of responsiveness to the environment, punctuated by intermittent hyperarousal in response to conditional traumatic stimuli. They exhibit heightened physiological arousal to sounds, images, and thoughts related to specific traumatic incidents and respond to such stimuli with significant conditioned autonomic reactions, such as changes in heart rate,

skin conductance and blood pressure. Traumatic memories continue with timelessness with no change in intensity (van der Kolk, 1997).

Differential effects of trauma occur at various age levels. Anxiety disorders, chronic hyperarousal, and behavioural disturbances have been regularly described in traumatized children. Severity of the syndrome is proportional to the age of onset of the trauma and its duration (van der Kolk, 1994).

2.1.6. TREATMENT OF PTSD

PTSD is treated by a variety of forms of psychotherapy and drug therapy. There is however no definite treatment or cure.

Initiating assessment and treatment quickly after the traumatic event may prevent many of the complications and disability associated with prolonged PTSD. Treatment is often best accomplished with a combination of pharmacological (see par. 2.4.) and non-pharmacological therapies. Medications may be required to control the physiological symptoms, which can enable the patient to tolerate and work through the highly emotional material in psychotherapy. Treatment often is complicated by co-morbid disorders. In the presence of alcohol or substance abuse, these problems should be the initial focus of treatment. Even in the presence of coexisting depression, treatment should focus on PTSD because the course, biology and treatment response are unlike that of major depression (Friedman, 2000; NCPTSD, 2000).

2.2. PATHOPHYSIOLOGY

2.2.1. DETECTION OF TRAUMA

Excessive stimulation of the central nervous system at the time of the trauma, may result in permanent neuronal changes that have a negative effect on learning, habituation, and stimuli discrimination. An abnormal startle response, that is characteristic of PTSD, exemplifies such neuronal changes. The startle response is mediated by excitatory amino acids, such as glutamate and aspartate, and is modulated by a variety of neurotransmitters and second messengers at both the spinal and the supra-spinal level (Kolb, 1987; van der Kolk, 1994). The abnormal

startle response reflects people with PTSD's inability to properly integrate memories of trauma (van der Kolk, 1994).

As seen in Figure 2-1, detection of trauma occurs across a range of modalities including vision, hearing, smell and touch. This leads to registration of the stressor as memory and promotes a response. The amino-acid transmitters, glutamate and GABA, are intimately involved in the process of factual memory registration, and current knowledge suggests that amine neurotransmitters, such as noradrenalin and serotonin, are involved in encoding emotional memory (Nutt, 2000).

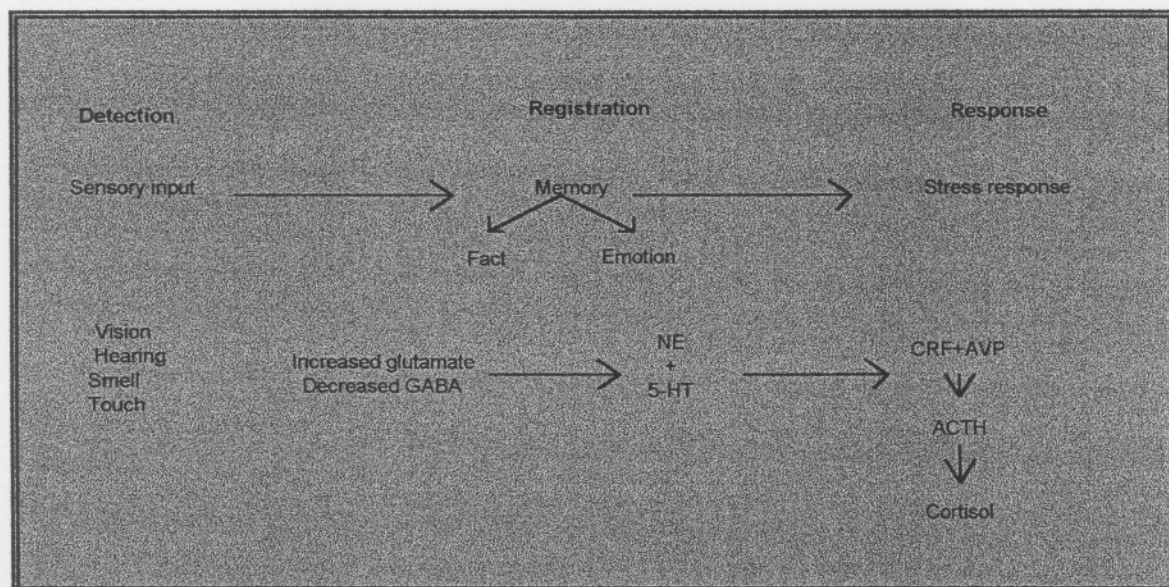

Figure 2-1 Detection modalities and psychobiological modulators in stress response (Nutt, 2000). (NE=noradrenaline; 5-HT=serotonin; CRF=corticotrophin releasing factor; AVP=arginine vasopressin; ACTH=adrenocorticotrophic hormone)

2.2.2. MEMORY DEFICITS IN PTSD

PTSD patients demonstrate a variety of memory problems. The two typical types of memory disturbances identified in traumatized individuals are intrusive memories and impoverished memory functioning (APA, 1994). Intrusive memories may be experienced as reenactments of the original trauma, and are accompanied by high levels of arousal. In general, these memories are triggered automatically by situations that reflect aspects of the traumatic event (Bremner *et al*, 1999; Elzinga & Bremner, 2002).

The second category of memory disturbances in PTSD-patients is concerned with impoverished memory functioning due to diminished encoding or impaired retrieval abilities. PTSD-patients may report deficits in declarative memory (remembering events, facts or lists), fragmentation of memories (both autobiographical and trauma-related), and amnesia (gaps in memory that can occur for minutes to days). These are not due to ordinary "forgetting" (Elzinga & Bremner, 2002).

Memory functioning can be divided into declarative (explicit) and non-declarative (implicit) memory processes. Declarative memory refers to the ability to consciously remember and reproduce events and facts. Implicit memory refers to affective and behavioral knowledge of an event without conscious memory, including learning skills, priming, and conditioning. In patients with PTSD, implicit memory processes may automatically facilitate access to information about the traumatic event and hence underlie fear conditioning and re-experiencing phenomena observed in patients with PTSD. Explicit memory is related to declarative memories of the trauma that contain explicit information about the sensory features of the situation, the emotional and physiological reactions experienced, and the perceived meaning of the event (Elzinga & Bremner, 2002).

PTSD, by definition, is accompanied by memory disturbances, consisting of both hypermnesias and amnesias. Trauma interferes with declarative memory, i.e. conscious recall of experience, but does not inhibit implicit or non-declarative memory i.e. the memory system that controls conditioned emotional responses, skills and habits, and sensorimotor sensations related to experience. Sensory experiences and visual images related to the trauma seem not to fade over time, and appear to be less subject to distortion than ordinary experiences (van der Kolk, 1994).

Physiological arousal in general can trigger trauma-related memories, while trauma-related memories precipitate generalized physiological arousal. Frequent reliving of a traumatic event in flashbacks or nightmares causes further release of stress hormones, which further kindle the strength of the memory traces (van der Kolk, 1994). High and escalated stress usually impairs learning and memory such as

long-term potentiation, whereas mild or moderate stress can support both learning and long-term potentiation (McGaugh & Roozendaal, 2002).

2.2.3. PROCESSING OF EMOTIONALLY CHARGED MEMORIES: THE LIMBIC SYSTEM

The limbic system is reported to be the part of the central nervous system that maintains and guides the emotions and behavior necessary for self-preservation and survival. The limbic system is also critically involved in the storage and retrieval of memory (MacLean, 1985).

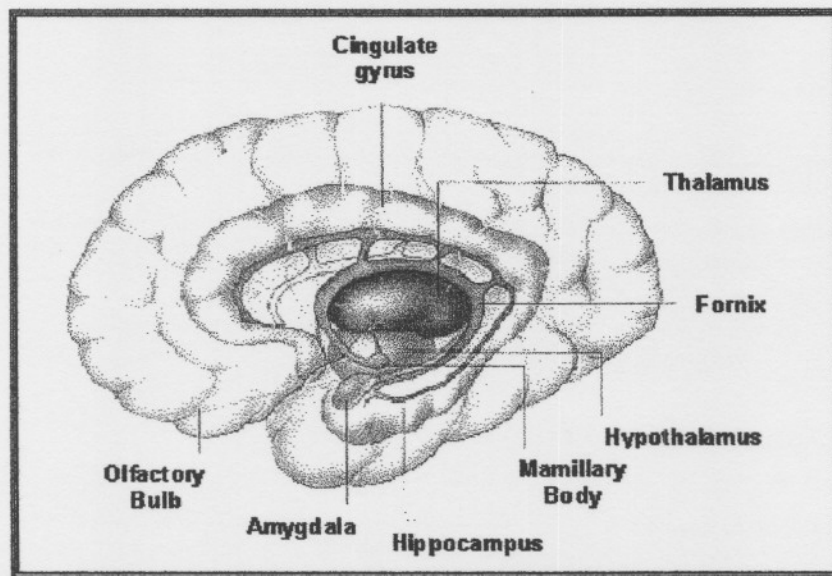

Figure 2-2 Schematic presentation of the limbic system. The limbic system is a group of brain structures that includes the hippocampus, dentate gyrus, septal areas, amygdala and parts of the diencephalons. These structures are associated with autonomic functions, motivation, emotion, recent memory and olfaction. (Scholey, 2002).

Two areas of the limbic system, implicated in the processing of emotionally charged memories, are the amygdala and the hippocampus (NCPTSD, 2000).

2.2.3.1. AMYGDALA

The amygdala is involved in coordinating the body's fear response. PTSD may thus be associated with abnormal activation of the amygdala (Davidson *et al*, 1999; NCPTSD, 2000). The amygdala is clearly implicated in the evaluation of the emotional meaning of incoming stimuli. The amygdala assigns free-floating feelings

of significance to sensory input, which the neocortex then further elaborates and imbues with personal meaning. The amygdala guides emotional behavior by projections to the hypothalamus, hippocampus and basal forebrain. The septo-hippocampal system, which is anatomically adjacent to the amygdala, is thought to record in memory the spatial and temporal dimensions of experience, and to play an important role in the categorization and storing of memory (van der Kolk, 1994).

2.2.3.2. HIPPOCAMPUS

One of the most important brain areas that mediates, and in turn is affected by the stress response, is the hippocampus (Bremner, 1999; Elzinga & Bremner, 2002; McEwan *et al*, 1997; Sapolsky, 1996; Uno *et al*, 1989). The hippocampus plays an important role in new learning and memory, and proper functioning of the hippocampus is necessary for explicit or declarative memory. The hippocampus is thought to be involved in the evaluation of spatially and temporally related events, comparing them with previously stored information, and determining whether and how they are associated with each other, with reward, punishment, novelty, or non-reward. The hippocampus is also implicated in playing a role in the inhibition of exploratory behavior and in obsessional thinking, while hippocampal damage is associated with hyper-responsiveness to environmental stimuli. Damage to the hippocampus resulting from stress, can not only cause problems in dealing with memories and other effects of past stressful experiences, it can also impair new learning (Bodnoff *et al*, 1995; Bremner, 1999; Elzinga & Bremner, 2002, Luine *et al*, 1994).

The hippocampus has the capacity to regenerate nerve cells as part of its normal functioning, but stress impairs that function by stopping or slowing down neuron regeneration (Gould & Tanapat, 1999; Elzinga & Bremner, 2002). This impairment of neurogenesis has been linked to stress-induced increases in adrenal steroids that act to exacerbate excessive glutamatergic transmission via NMDA receptors (Cameron *et al*, 1995) (see par. 3.2.1. & par. 3.2.2.).

2.3. NEUROCHEMISTRY OF PTSD

2.3.1. REDUCTION IN HIPPOCAMPAL VOLUME: GLUCOCORTICOIDS

When people are under severe stress, they secrete endogenous stress-responsive neurohormones such as glucocorticoids, adrenaline and noradrenaline, vasopressin, oxytocin, and endogenous opioids that affect the strength of memory consolidation. Massive secretion of neurohormones at the time of trauma plays a role in the long-term potentiation of traumatic memories. Stress hormones also help the body mobilize the required energy to deal with the stress, ranging from increased glucose release to enhanced immune function (Axelrod, 1984).

Glucocorticoids which, acting on the hippocampus, amygdala and prefrontal cortex, as well as other areas, influences memory function in the long-term by inhibiting the laying down of memory traces (Elzinga & Bremner, 2002). Prolonged exposure to stressful events is associated with a marked increase in the release of glucocorticoids from the adrenal gland (Bremner *et al*, 1999; Heim & Nemeroff, 1999). The hippocampus regulates glucocorticoid release through inhibitory effects on the hypothalamic-pituitary-adrenal (HPA) axis indicating that the hippocampus is an important centerpiece for integrating cognitive, neuro-hormonal, and neuro-chemical responses to stress (Bremner, 1999; Bremner *et al*, 1999). Unlike other brain structures, the dentate gyrus of the hippocampal formation undergoes continual structural remodeling in adulthood (Gould & Tanapat, 1999). This is another factor that makes the hippocampus particularly sensitive to environmental and experience-dependant changes.

Extreme stress results in an acute increase in glucocorticoid levels. Studies in normal human subjects have shown that glucocorticoids have direct effects on memory function; hippocampal damage is associated with direct exposure of the hippocampus to glucocorticoids, resulting in decreased dendritic branching, alterations in synaptic terminal structure, and a loss of neurons and an inhibition of neuronal regeneration (Bremner *et al*, 1999).

If hippocampal damage occurs, the normal negative feedback loop of the HPA system is changed to a positive feedback loop that increases the exposure of the hippocampus to glucocorticoid toxicity (Heim & Nemeroff, 1999; Nutt, 2000;

Sapolsky, 2000a; Sapolsky, 2000b). Together, these mechanisms are proposed to perpetuate damage to the hippocampus, resulting in reduced hippocampal volume (Nutt, 2000; Sapolsky, 2000a; Sapolsky, 2000b).

The most pronounced indication of the effect of increased glucocorticoid levels on hippocampal volume is seen in patients with Cushing's syndrome, where hyperfunctioning of the adrenal cortex results in increased secretion of glucocorticoids. Smaller hippocampal volumes were reported in adults with Cushing's syndrome, similar to patients with PTSD (Sapolsky, 2000b; Starkman *et al*, 1992).

Glucocorticoids have various adverse effects in the hippocampus (Sapolsky, 2000b), including:

- o induction of regression of dendritic processes;
- o inhibiting neurogenesis;
- o impairing the ability of neurons to survive coincident insults, thereby worsening the neurotoxicity of seizures, hypoxia-ischemia, metabolic poisons, hypoglycemia, and oxygen radical generators;
- o and, with sufficient exposure to excessive glucocorticoids, neurotoxicity.

These effects contribute to hippocampal atrophy.

A prime mediator of glucocorticoid-induced toxicity appears to be glutamate, an excitatory amino acid (Sapolsky, 2000b). Psychobiological research, using animal models, has shown that stress-induced elevations of glucocorticoids, such as corticosterone, augment the effects of excitatory amino acids, such as glutamate, resulting in structural damage within the brain and abnormal brain function i.e. impaired learning and memory (Bremner *et al*, 1999). The term glucocorticoids refers to both corticosterone and cortisol. Corticosterone is the main secreted glucocorticoid in rats, while in humans cortisol is the main secreted product (Barrington, 1975).

Both stress and glucocorticoids increase glutamate concentrations in the hippocampal synapse. Furthermore, glucocorticoids selectively increase glutamate accumulation in response to excitotoxic insults, both in hippocampal cultures and in the hippocampus in vivo (Sapolsky, 2000b).

Glucocorticoids, in addition, increase the free cytosolic calcium load in the hippocampus worsening the response to insult, both through direct post-synaptic effects and by indirectly increasing the glutamatergic tone impinging on the neuron. The hormone also worsens oxygen radical accumulation during insults, an effect likely to arise, at least in part, from the ability of glucocorticoids to decrease the activity of some antioxidants (Sapolsky, 2000b).

The important effects of the stress hormones, glucocorticoids, on the hippocampus, are consistent with the hypothesis that the hippocampus plays a possible role in stress-related psychiatric disorders (Bremner *et al*, 1999). PTSD, however, is not associated with increased glucocorticoid levels as seen in other anxiety-related disorders, but with a decrease in glucocorticoid levels below basal levels (Boscarino, 1996; Heim *et al*, 2000; Yehuda *et al*, 1996; Yehuda, 1997), thus implying that glucocorticoid secretion alone is not responsible for the hippocampal atrophy and subsequent memory deficits seen in patients with PTSD.

2.3.2. INVOLVEMENT OF CYTOKINES

Exposure to trauma can result in immune dysregulation, and increasing evidence suggests that there are immune alterations associated with PTSD (Wong, 2002). Localized production of cytokines and chemokines accompanies inflammation in the central nervous system in many debilitating neurological disorders, such as multiple sclerosis, Alzheimer's disease and neuro-AIDS. Cytokines are pivotal modulators of inflammatory processes (Campbell *et al*, 2003a; Campbell *et al*, 2003b). Psychological stress in humans is associated with increased secretion of pro-inflammatory cytokines, such as interleukin-6 (Maes *et al*, 1999), whose secretion is suppressed by glucocorticoids and stimulated by catecholamines (Baker *et al*, 2001). Patients with PTSD have been found to have decreased glucocorticoid levels (see par. 2.3.1.) and increased catecholamine secretion. In studies done to determine the plasma and cerebrospinal fluid interleukin-6 concentrations in patients with PTSD, high levels of cerebrospinal fluid interleukin-6 have been measured, explaining possible neuro-degeneration (Baker *et al*, 2001).

Recent studies have shown that interleukin-6 is expressed at elevated levels in the central nervous system in several disease states, and interleukin-6 contributes to the neuropathological process. Chronic interleukin-6 treatment of developing

cerebellar granule neurons were found to increase the membrane and current response to NMDA, and these effects are the primary mechanism through which interleukin-6 produces an enhanced calcium signal to NMDA. Interleukin-6 treatment was subsequently found to reduce the number of granule neurons in culture and enhance neurotoxicity involving NMDA receptors (Qui *et al*, 1998; see par. 3.2.2.1.).

Cytokines have also been implicated in the induction of inducible nitric oxide synthase (iNOS) through NMDA-receptor stimulation (Almeida *et al*, 1998; Snyder & Dawson, 2003). The primary function of NO, after activation of iNOS, is to kill pathogens. Increased levels of NO may however lead to neurotoxicity (Dawson & Dawson, 1996; see par.3.1.).

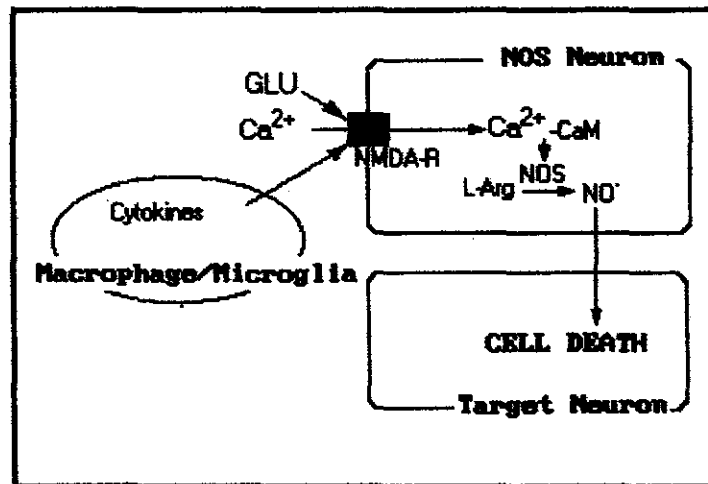

Figure 2-3 Mechanism of cytokine-induced neurotoxicity. Glutamate interacts with cytokines to activate the NMDA receptor, which increases intracellular calcium levels. NOS is subsequently activated, and excessive formation of NO kills adjacent neurons (Snyder & Dawson 2003).

2.3.3. HIPPOCAMPAL DAMAGE: GLUTAMATE AND GABA

The clinical characteristics of PTSD, as well as recent preclinical findings, suggest that dysfunctions of brain glutamatergic systems, in particular alterations of NMDA receptor-mediated neurotransmission, may represent a crucial component of PTSD symptomatology (Dawson & Dawson, 1996; Harvey, 1996).

The two components involved in primary sensory transmission are the excitatory amino acid, glutamate, and the inhibitory amino acid, GABA. Glutamate is the primary excitatory transmitter in the brain and plays an intimate role in the processes of consciousness and memory, by mediating sensory inputs in the brain (Collingridge & Bliss, 1995). GABA and glutamate release occur in tandem. The glutamatergic input is always excitatory, while the GABA input is inhibitory, and the fine balance between the amino acid transmitters in the brain prevents excessive levels of excitatory transmission from leading to adverse consequences such as seizures (Lydiard, 2003; Nutt, 2000). The consequence of extreme stress is probably mediated by a down-regulation of the GABA-system, allowing an excessive activation of the glutamate system that results in the laying down of factual memory (Nutt, 2000).

A large body of evidence supports a role for the glutamatergic and GABA pathways in the psychobiology of PTSD. Prolonged loss of consciousness following terrifying events appears to protect against the development of PTSD (Adler, 1993). Although coma is not yet fully understood, it is speculated to be partly induced by disruption of the glutamatergic pathway (O'Brien & Nutt, 1998). Additionally, dissociative states associated with the use of glutamate receptor blockers e.g. ketamine, are likely to be due to drug-induced disruption of glutamatergic transmission in the thalamus. Similarly, GABA-stimulating drugs such as ethanol and benzodiazepines exert some of their effect by suppressing glutamatergic function. These drugs are frequently used by patients with PTSD to prevent the reemergence of previously established memories and possibly the registration of new memories.

GABA is the main inhibitory neurotransmitter in the mammalian CNS acting on GABA-A (a ligand-gated chloride-ion channel, opened after release of GABA from postsynaptic neurons) and GABA-B (coupled both to biochemical pathways and to regulation of ion channels). GABA-A receptors are in abundance in the CNS and play a role in almost every neuronal circuit (Bloom, 2001). GABA-A receptors are found in high abundance in the CNS (Bloom, 2001), and binding of GABA to the GABA-A receptor, the most common receptor in the brain, inhibits the activation of most neurons (Nutt, 2000).

Glutamate acts on at least three receptor subtypes, classified functionally as either ligand-gated ion channels or as G-protein coupled receptors. Ligand-gated ion channels are further classified according to the identity of the agonist that selectively activate each receptor subtype incl. α -amino-3-hydroxy-5-methyl-4-isoxazole propionic acid (AMPA), kainate and N-methyl-D-aspartate (NMDA) receptors (see par. 3.2.2.). AMPA and kainate receptors mediate fast depolarization of most glutaminergic synapses in the brain and spinal cord. NMDA receptors are also involved in normal synaptic transmission, but activation of NMDA receptors is more closely associated with the induction of various forms of synaptic plasticity rather than fast point-point signaling (Bloom, 2001).

A well-characterized phenomenon that involves NMDA receptors is the induction of long-term potentiation (LTP) (see par. 3.2.2.2.). LTP refers to a prolonged increase in size of a postsynaptic receptor to a presynaptic stimulus of given strength. Activation of the NMDA receptor is obligatory for the type of LTP in the hippocampus (Collingridge & Bliss, 1995).

Acknowledgement of the role played by the glutamatergic and GABA pathways in the normal mechanism for encoding of memory lead to the hypothesis that PTSD is caused by overstimulation of the NMDA system. Excessive influx of calcium ions into the postsynaptic neurons may lead to strongly ingrained memories. This could be a possible mechanism by which the flash bulb memories of PTSD are generated. Overstimulation of the NMDA receptors will lead to high levels of calcium ions. These ions are extremely toxic to cells and will eventually induce cytotoxic cell death, which may be one of the key mechanisms by which brain cells are lost in PTSD (Nutt, 2000).

The hippocampus is either the most or among the most vulnerable of brain regions to neuron loss arising from seizure, hypoxia-ischemia, and hypoglycemia. This vulnerability has inspired considerable research as to its underlying causes. From this has emerged something resembling a central dogma centered on the preponderance of synapses in the hippocampus making use of glutamate as a neurotransmitter. During periods of repeated stimulation that characterizes learning, glutamate accumulates in the synapse and binds to glutamate receptors. The binding to and ultimate activation of the NMDA receptor causes mobilization

of free cytosolic calcium. Calcium enters the neuron through NMDA voltage-gated channels, as well as being released from intracellular organelles. This calcium mobilization activates the long-term changes in synaptic excitability that probably constitutes memory (Sapolsky, 2000a). The neurological insults just cited all involve an excess of glutamate accumulating in the synapse that, at sufficiently high concentrations becomes an excitotoxin. Excess cytosolic calcium is mobilized producing prominent overactivity of calcium-dependant enzymes e.g. nitric oxide synthase. This produces cyto-skeletal degradation, protein misfolding, and oxygen radical generation, which collectively lead to neuron death (Sapolsky, 2000a).

GABA pathways also play an important role in regulating normal affective state (Shiah and Latham, 1998), and form an integral part of the stress response (Nutt, 2000). GABA moreover acts to prevent excessive NMDA receptor activation (Nutt, 2000), especially through inhibition of glutamatergic transmission via GABA activation of pre-synaptic GABA-B heteroreceptors (Yamada *et al*, 1998). Of interest is that swim stress-induced GABA release in the hippocampus is potentiated by nitric oxide (Engelman *et al*, 2002), while GABA-A and GABA-B receptor agonists attenuate stress-induced release of nitric oxide (Ishizuka, 2000). GABA-A receptor expression is also under the regulation of nitric oxide (Kim & Oh, 2002). These responses describe an important protective mechanism to curb excessive glutamate-NOS activation. Excess NOS activation, resulting in excessive nitric oxide formation, is implicated in neurotoxic processes in the central nervous system (see par.3.5.2.).

2.3.3. INVOLVEMENT OF OTHER NEUROTRANSMITTERS IN THE PATHOPHYSIOLOGY OF PTSD

Accumulative evidence suggests that biological dysregulation of several central pathways plays a fundamental role in the pathology of PTSD. These biological changes cause brain structural and functional abnormalities that manifest as symptoms, such as the hyperarousal and flashbacks classically associated with PTSD (Nutt, 2000).

i) Noradrenergic system

Centrally, catecholamine neurons seem to play a critical role in the level of alertness, vigilance, orientation, selective attention, memory, fear conditioning, and cardiovascular responses to life-threatening stimuli (Southwick *et al*, 1999). Evidence of catecholamine dysregulation in PTSD includes exaggerated increases in heart rate and blood pressure when exposed to visual and auditory reminders of the trauma, elevated 24-hour urine catecholamine excretion, and decreased α -2 adrenergic receptor number (Ellingrod, 1996; Southwick *et al*, 1999; Sutherland & Davidson, 1994).

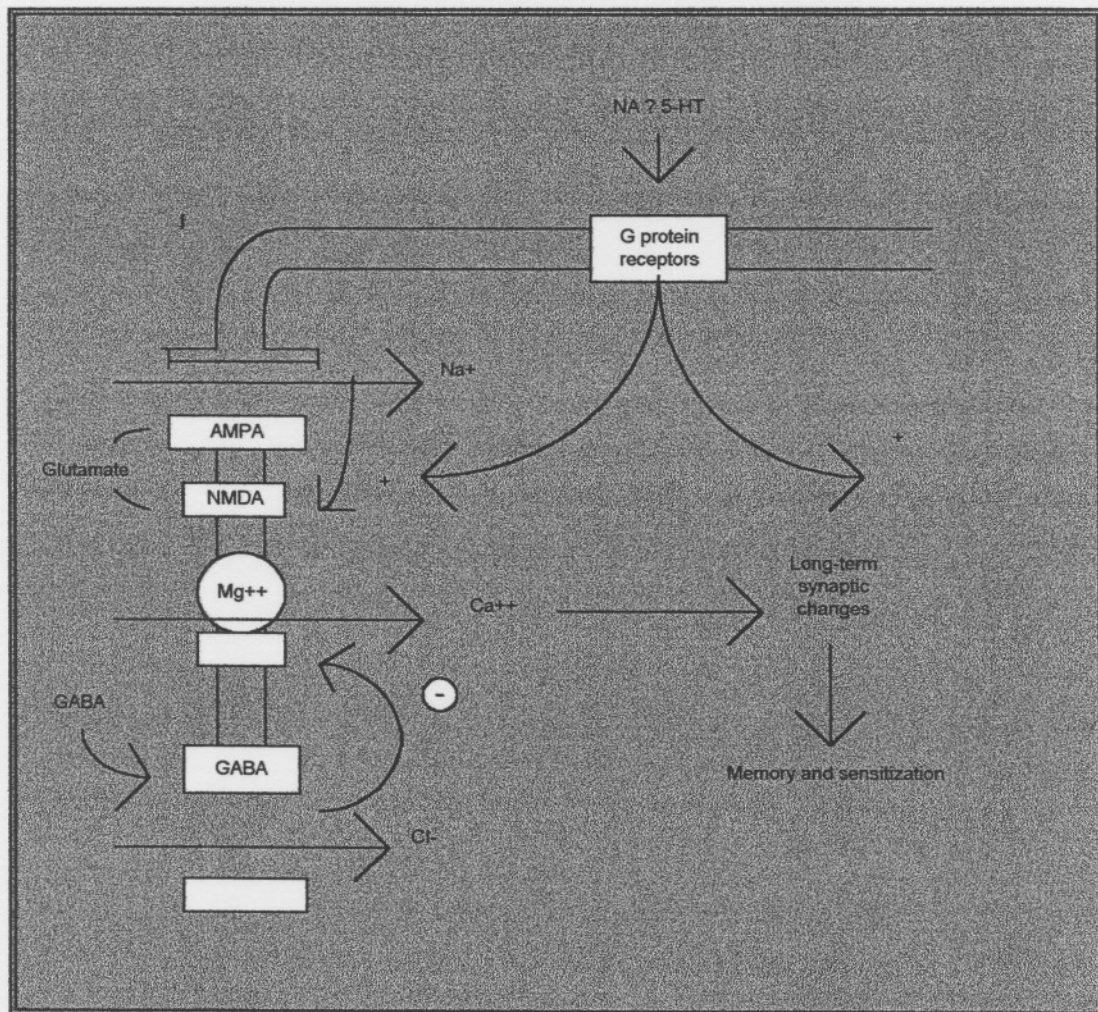

Figure 2-4 Mechanism of GABA/glutamate pathway in the laying down of memory and sensitization to stress, and inter-relationship of the pathway with the neuroamine transmitter pathways (Nutt, 2000).

ii) Serotonergic system

Although the exact dysregulation in serotonergic function is not known, several animal models have suggested that central serotonergic activity may play a role in PTSD. Two serotonergic pathways have been identified as having relevance in the development of PTSD symptoms. One of these pathways, which arises from the dorsal raphe nucleus and innervates the amygdala, involves postsynaptic 5-HT₂ - receptors that mediate the development of conditioned avoidance behaviors. The second pathway arises from the median raphe and innervates the hippocampus and appears to mediate resilience and adaptation to stress. It is felt that serotonergic drugs may prove helpful in the avoidance and impulsiveness associated with PTSD (Ellingrod, 1996). High levels of corticosterone downregulate serotonin binding in the hippocampus, suggesting an important and complex triangular relationship between the HPA-axis, glutamate, and serotonin in the neural circuits implicated in the stress-response (Lopez *et al*, 1999).

iii) Dopaminergic system

Animal studies have suggested a role for the meso-cortical dopaminergic system in memory and attention alterations. These animal studies also suggest a preferential increase in meso-prefrontal cortical dopamine, which may be altered by several neurotransmitters including NMDA, opiate receptor blockade, and benzodiazepine pre-administration (Ellingrod, 1996).

iv) Opioid system

The opioid system is known to be involved in the stress response leading to stress induced analgesia (Akil *et al*, 1983; Ellingrod, 1996). Self-reports of emotional responses suggest that endogenous opioids are responsible for a relative blunting of the emotional response to the traumatic stimulus (van der Kolk, 1994).

2.4. PHARMACOTHERAPY

Success in the treatment of PTSD has been claimed for several classes of psychoactive medication, including benzodiazepines, tricyclic antidepressants, monoamine oxidase inhibitors, lithium carbonate, beta adrenergic blockers and clonidine, carbamazepine and antipsychotic agents (van der Kolk, 1995).

As seen in Table 2-1, selective serotonin re-uptake inhibitors were the first drugs indicated for the treatment of PTSD, and the SSRI's, such as fluoxetine and sertraline, are currently the most widely-used drug treatment for PTSD (NCPTSD, 2000). Sertraline was the first SSRI to have received approval for PTSD treatment (Friedman, 2000), and subsequently fluoxetine was found to have profound effects on numbing arousal, and to a lesser degree, on intrusions. Fluoxetine has a significant positive effect on the dimensions of affect dysregulation, distorted relationships with others, and loss of sustaining beliefs. The beneficial effects of fluoxetine is not a function of its antidepressant effects but instead, by making people with PTSD feel less numb and more in tune with their surroundings, fluoxetine is likely to make them feel better equipped to deal with residual trauma-related fears, recollections, and intrusions (Argypolous *et al*, 2000; van der Kolk, 1995).

Table 2-1 Drugs used in the treatment of PTSD (Friedman, 1997).

Group	Drug	Effects
Selective serotonin reuptake inhibitors	Sertraline Fluoxetine	The first drugs approved for the treatment of PTSD. May be effective in reducing some symptoms in at least some patients. May be particularly useful in the treatment of women who have experienced sexual or physical assaults.
Monoamine oxidase inhibitors	Phenelzine	In a double-blind placebo-controlled trial, it was suggested that phenelzine was efficient in reducing intrusion symptoms. Has demonstrated clear superiority over placebo in double-blind trials for treating specific symptoms of panic disorders. Usually reserved for patients who do not tolerate / respond to traditional cyclic or second-generation antidepressants.
Beta-blockers	Propranolol	Relieves the exaggerated startle response, nightmares, and intrusive re-experiencing in some patients.

PTSD symptoms are reduced by antidepressants and some anxiolytic compounds. The magnitude of these responses however, is far from that obtained in major depression or in panic attacks (Huresco-Levy & Javitt, 1998). Clinical experience indicates that most PTSD patients are left with substantial degrees of distress and dysfunction, suggesting that pathophysiological substrates are not affected by presently available pharmacological interventions (Huresco-Levy & Javitt, 1998).

2.4.1. PROSPECTUS

An important finding regarding the antidepressants is that all currently marketed antidepressant classes, including the SSRI's, modulate the N-methyl-D-aspartate (NMDA) class of glutamate receptors, and there are preclinical and clinical suggestions that glutamatergic NMDA-receptor antagonists function as antidepressants and anxiolytics (Skolnick, 1999). Evidence suggests that glutamate may represent the ultimate pathway by which all presently used antidepressants mediate their psycho-modulatory action. It has also been proposed that this excitatory amino acid has a primary role in treatment resistance and recurrence of affective illness, and thus it may determine long-term prognosis of the illness (Dawson & Dawson, 1996; Harvey, 1996).

Most drugs tested in PTSD were developed as antidepressants and later shown to have efficacy against panic and other anxiety disorders (van der Kolk, 1994; van der Kolk, 1995). Given co-morbidity rates between PTSD and such disorders and given the overlap between major depression, PTSD, panic disorder and generalized anxiety disorder, it seems reasonable to have tested such drugs in PTSD. On the other hand, PTSD appears to be distinctive in a number of ways. First, it seems to be more complex than affective and other anxiety disorders, and second, its underlying pathophysiology appears to be qualitatively different. For example, abnormalities in the hypothalamic-pituitary-adrenocortical axis (HPA) system are markedly different from those present in major depressive disorder despite similarities in clinical phenomenology (Boscarino, 1996; Heim *et al*, 2000; Yehuda *et al*, 1996; Yehuda, 1997). There thus exists the need to develop drugs specifically for PTSD rather than to recycle pharmacological agents that has been developed to treat affective or other anxiety disorders.

2.5. ANIMAL MODELS OF PTSD

Several reasons make it desirable to use animal models to simulate human processes and disorders (Richter-Levin, 1998):

- A human condition can be stimulated in a larger number of subjects, and circumstances during the study can be more easily controlled than in human subjects;
- Human disorders can be studied only after they become clinically manifest, whereas animal models are observable as they evolve, permitting the study of symptoms as they develop;
- Animal models also allow the testing of pharmacological and other prospective treatment that might be difficult to test in humans.

PTSD has great potential to be accurately modeled in animals because the major precipitating factors are known, namely PTSD occurs in response to severe and unusual stressful or traumatic situations (Richter-Levin, 1998).

There are however several points that require consideration when trying to model this disorder. Although a wide range of stressors can induce PTSD in humans, animal studies of stress have shown marked bio-behavioral differences depending on the type of stressor applied (Richter-Levin, 1998). Differences in response of the animals to the stressor applied can be influenced by factors other than the actual stressor, such as the state of the organism during stress, and even its genetic makeup (King *et al*, 2001). Diagnosis in human patients relies heavily on personal reports of thoughts, dreams and images (Kaplan *et al*, 1994), which cannot be studied in rats, thus several of the typical symptoms of PTSD may be unique to humans and thus not be found in rats. Humans exposed to trauma, perceive the life-threatening potential of the situation (Kaplan *et al*, 1994; Richter-Levin, 1998). It is not clear whether rats can make this judgment or which stressors will be most effective for rats. Finally, the stressor may be only one of many important variables contributing to the development of PTSD. Exposure to a stressor is thus certainly a necessary condition for induction of PTSD, but it is clear that this factor alone may not be sufficient for the manifestation of PTSD.

Literature, however, indicates that rat models are accepted as a valid means for understanding the common underlying mechanisms that generate emotions and emotional disorders (Richter-Levin, 1998). Stress sensitization induced in animals by brief, intense stressful events can yield a syndrome that includes behavioural and physiological disturbances mimicking key-symptoms of anxiety and other affective disorders (Uys *et al*, 2003).

Animal models of PTSD have used intense stressors, aversive challenges, and situational reminders of traumatic events in an attempt to model long-term effects on behavioural, autonomic, and hormonal responses seen in humans with PTSD. Examples of these models include electric shock, stress-restress or time-dependant sensitization, underwater trauma, and exposure of animals to a predator (Uys *et al*, 2003). The most familiar of these animal models are the learned helplessness (LH) model (Yehuda & Antelman, 1993) and the time-dependant sensitization (TDS) model (Liberzon *et al*, 1997).

The classic LH-model is based on exposure to brief electric foot shocks and thus selectively utilizes an unpredictable, uncontrollable stress event to determine individuals with an escape deficit in a subsequent controllable stress paradigm. In this model a change in various parameters such as activity, cognitive function, and dysregulation of the HPA-axis overlaps with changes observed in human PTSD (King *et al*, 2001). Researchers have used this acute LH model to better understand the possible neurobiological factors underlying PTSD. The appeal of this experimental paradigm is that it appears to have "face validity", because traumas known to give rise to PTSD, such as rape, natural disasters, or combat, occur without control of the individual. Literature however, points out that superficial face validity is only the first step in establishing a model (Yehuda & Antelman, 1993); a stringent behavioural analysis is necessary to determine in which ways the behaviour is similar and in which it differs from the human disorder. The model of learned helplessness was initially proposed, and is still being studied, as a model of depression, because both the finding of noradrenalin depletion and the behavioural passivity found with this model appeared to reflect clinical aspects of the disorder. This model is also accepted as an animal model for PTSD (Krystal *et al*, 1989), despite the fact that major depression and PTSD have now been shown to be distinct from one another from a clinical and biological perspective (Yehuda *et*

al, 1990, 1991a, 1991b).

Another paradigm that has been proposed as modeling the clinical syndrome of PTSD, is the TDS model (Antelman, 1988; Rosen and Fields, 1988). TDS refers to the fact that a single exposure to a stressor, e.g. immobilization stress, can induce long lasting alterations in the organism (Yehuda & Antelman, 1993). In this paradigm, rats receive one typically very brief exposure to an inducing stressor and are later tested with the same or another recall stressor. The rationale of the recall-stressor being that the frequency of exposure to situational reminders contributes to the maintenance of fear-related behavioural disturbances over time (Liberzon *et al*, 1997; Uys *et al*, 2003). Physiological and behavioral responsivity to the second stressor are significantly altered in animals previously exposed, compared with those receiving the stressor for the first time. In those instances where more than one interval between the inducing and recall stimuli has been measured, it has been shown that this effect progresses with time since the first stressor (Antelman, 1988). This model has proved valuable for studying HPA-axis abnormalities relevant to PTSD (Liberzon *et al*, 1997). Animals subjected to TDS-stress display the enhanced sensitivity to negative glucocorticoid feedback that is characteristic of PTSD, while also demonstrating distinct changes in mineralocorticoids and glucocorticoid receptor expression in the hippocampus (Liberzon *et al*, 1999). In addition, stress-restress evokes significant spatial memory deficits together with lowered plasma corticosterone, which is again consistent with clinical findings (Harvey *et al*, 2003). From a phenomenologic and biologic perspective, the TDS-model emphasizes the role of past trauma in predicting subsequent dysfunction, allows for the study of bi-directional expression of symptoms (enhanced or reduced responsiveness to environmental stimuli) and provides credible intra-subject variation (Yehuda & Antelman, 1993).

All the animal-models for the induction of PTSD-like sequelae are based on stress-induced, time-dependant sensitization. These different models have all shown validity in causing stable, long-term changes after brief but intense stressful events, and the alterations in behavioural reactivity, hormonal and autonomic function show many parallels with those in PTSD (Stam *et al*, 2000). There are, however, also differences in aspects of the observed long-term syndromes between the various animal models. One important factor in this respect is the intensity of the stress

experience, as well as the induction of long-lasting changes in brain substrates that specifically relate to their modalities (Stam *et al*, 2000). These substrates differ for painful, social or psychological stimuli and the type of challenge used appears to be of considerable importance for sensitization to be expressed (Stam *et al*, 2000).

In a review by Yehuda & Antelman (1993), it was concluded, that the TDS-model was a more promising behavioural model for induction of PTSD-like sequelae in experimental animals. It can be induced by stressful events imposed on the organism for only seconds, or, alternatively, by more chronic and severe stressors. Such persistent TDS effects have been shown to last at least one month (Antelman *et al*, 1988, 1989a, 1989b). The consequences of the TDS-model were also shown to grow stronger with the increased passage of time, similar to what is observed in chronic or delayed PTSD (Antelman, 1991a, 1991b; Liberzon *et al*, 1997). As mentioned, the effects of TDS can be either excitatory or inhibitory (Antelman, 1991a, 1991b) and the effects appear to show marked interindividual variability (Antelman *et al*, 1992).

The implementation of animals models in the study of anxiety and stress disorders have broadened the understanding of the neuroanatomy and neurochemistry of anxiety disorders, thus motivating the use of a widely-implemented animal model in our current study.

3. NITRIC OXIDE

Nitric oxide (NO) is an unusual messenger molecule. In the central nervous system NO is produced enzymatically in post-synaptic structures in response to activation through excitatory amino acid neurotransmitters. It then diffuses out to act on neighbouring cellular elements, probably pre-synaptic nerve endings and astrocyte processes. It is also formed pre-synaptically and thus acts as a second messenger. In both cases, a major action of NO is to activate soluble guanylate cyclase and so raise cGMP levels in target cells (Garthwaite, 1991).

Several findings indicate that nitric oxide plays an important role in anxiety-related behaviours. High concentrations of the NO-producing enzyme nitric oxide synthase (NOS) can be found in brain regions involved in the modulation of anxiety and defensive behaviour, including the amygdala, hypothalamus, periaqueductal grey, and pedunculopontine tegmental nucleus (Vincent & Kimura, 1992). Exposure to stressful stimuli has been found to induce the activation of NO-producing neurons in these brain regions (Krukoff & Khalili, 1997), while blockade of NO-synthesis results in decreased anxiety-like behaviour in several models of anxiety (Podhorna & Brown, 1999).

In the nervous system, the phenomenon called excitotoxicity has been related to over-production of free radicals by the tissue, and the neurotoxic effects of excessive NO-production are well-confirmed (Bolanos *et al*, 1997).

3.1. BACKGROUND ON NITRIC OXIDE

NO is an uncharged molecule with an unpaired electron, called a radical molecule, and is highly reactive (Lowenstein *et al*, 1994). NO is potentially toxic, although it has less relative chemical reactivity than other paramagnetic molecules (Gartwaite, 1991). NO is a gas at temperatures as low as -152°C.

NO can cross biological membranes by simple diffusion, just like O₂ and CO₂ (Kerwin & Hellar, 1994), and has an *in vivo* diffusion distance of at least 95µm (McCaslin & Oh, 1995), thus enabling it to act as a messenger molecule (Lowenstein *et al*, 1994).

NO acts as a neural messenger in the central nervous system and is synthesized through the activation of calcium-dependant neuronal nitric oxide synthase (nNOS) after glutamate receptor stimulation (Almeida *et al*, 1998; McCaslin & Oh, 1995). NO differs from conventional neurotransmitters in that it is not present in synaptic vesicles, it is not released by exocytosis, and no specific extracellular synaptic receptors for NO exists (Garthwaite, 1991; Ignarro, 1991).

The small molecular size, lipophilic nature, and chemical instability of NO, makes it well suited for its role in local transcellular communication. These physicochemical properties also make it unnecessary to have special membrane transporters or enzyme systems for terminating the action of NO (Ignarro, 1991).

3.1.1. CHEMICAL REACTIONS OF NO

NO has a half-life of about 7s (McCaslin & Oh, 1995) and, after transmitting a signal, is rapidly inactivated by reacting with O₂ to form nitrite and nitrates, and also with O₂^{•-} to form an unstable intermediate peroxynitrite anion (ONOO⁻) (Kerwin & Hellar, 1994).

A free radical is defined as any species that contains one or more unpaired electrons and are capable of independent existence. Reactive oxygen species are free radicals that are produced during normal cellular function as accidental by-products of metabolism, but also deliberately during, for example, phagocytosis, and include hydroxyl radicals ([•]OH), superoxide anion (O₂^{•-}), hydrogen peroxide (H₂O₂) and nitric oxide (NO[•]). These are transient species due to their high chemical reactivity that leads to lipid peroxidation and oxidation of some enzymes, as well as protein oxidation and degradation (Cheeseman & Slater, 1993; Matés, 2000).

The reaction between oxygen free radicals and polyunsaturated fatty acids results in lipid peroxidation. Lipid peroxidation is a well-established mechanism of cellular injury in both plants and animals, resulting in a severe loss of membrane functional integrity and oedema formation (Lewen *et al*, 2000).

NO can be both an oxidising (NO^+) and a reducing (NO^\bullet and NO^-) agent. NO has an additional electron that is readily lost to result in the formation of a nitrosonium cation (NO^+), or in a less preferential reaction, form a nitroxyl anion (NO^-) through addition of an electron (McCaslin & Oh, 1995). Iron and thiol provide the key link between NO and its redox states in biological systems. The physiological reactions of NO are primarily with O_2 , superoxide anion (O_2^-), thiol, and transition metals (see fig. 3-1 and 3-2) (McCaslin & Oh, 1995).

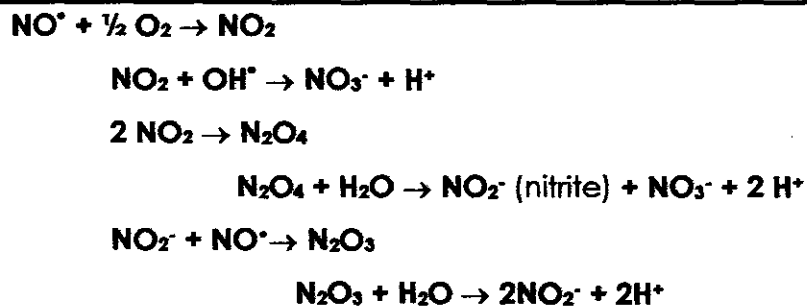

Figure 3-1 Chemical reaction of NO with O_2 (McCaslin & Oh, 1995).

NO reacts with O_2^- to produce peroxynitrite (ONOO^-), a long-lived and strong oxidant that combines chemically with many cellular components, e.g. ONOO^- reacts with H^\bullet to produce a hydroxyl radical (HO^\bullet) and a nitrogen dioxide radical (NO_2^\bullet). ONOO^- spontaneously degrades into NO_3^\bullet (McCaslin & Oh, 1995).

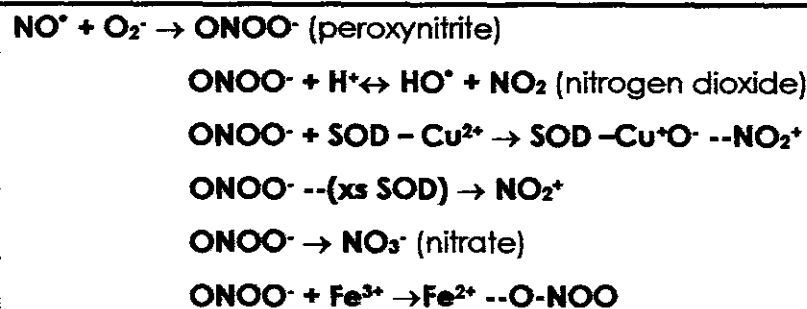

Figure 3-2 Chemical reactions of NO with O_2^- (McCaslin & Oh, 1995).

NO reacts with transition metals such as the iron-porphyrin and iron-thiol centres in proteins to form a nitronium ion- (NO_2^+) complex with the iron. As with ONOO^- , NO also reacts with iron porphyrin and iron thiol to form a similar NO^+ with the iron, that can be readily transferred to electron-rich substrates such as thiol and amines. The thiols of cysteine and cysteine-containing molecules can react with NO, independently of transition metals, to form S-nitrosylations and equivalent NO^+ thiols. Protein is the major source of buffering free NO in plasma (McCaslin & Oh, 1995).

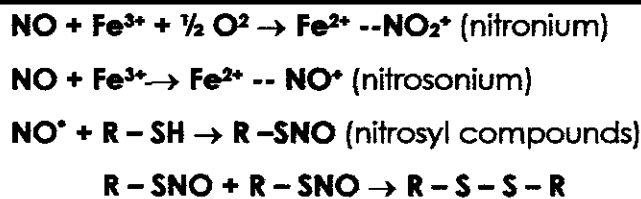

Figure 3-3 Chemical reaction of NO with iron and thiol (McCaslin & Oh, 1995).

Another redox form of NO, NO^- , can be formed from the reaction of NO with iron porphyrin. NO^- undergoes rapid dimerization and dehydration to form the stable and unreactive anaesthetic gas, nitrous oxide (McCaslin & Oh, 1995).

Within the central nervous system and under normal conditions, NO appears to be an important physiological signalling molecule. Under certain circumstances NO-synthesis may become excessive and NO may become neurotoxic. Excessive glutamate receptor stimulation may lead to neuronal death through a mechanism implicating synthesis of both NO and superoxide, and hence peroxynitrite formation (Bolanos *et al*, 1997).

3.2. STIMULATION OF NO-SYNTHESIS

3.2.1. GLUTAMATE

The excitatory amino acid neurotransmitter, glutamate, acting through amino acid receptors, triggers the generation of NO in the central nervous system. By increasing intracellular calcium levels, glutamate activates several enzymatic pathways, including NOS, which leads to the formation of the free radical nitric oxide (Almeida *et al*, 1998; Lewen *et al*, 2000; McCaslin & Oh, 1995).

Glutamate is involved in energy metabolism, protein synthesis, ammonia detoxification, and neurotransmission (Fonnum & Hassel, 1995).

Excitotoxicity is a term used to describe the ability of glutamate and related excitatory amino acids to destroy neurons (Fonnum & Hassel, 1995). Glutamate appears to be a mediator of glucocorticoid-induced neurotoxicity; both stress and glucocorticoids have been found to increase pre-synaptic release of glutamate in the hippocampus, resulting in excessive synaptic glutamate levels (Nutt, 2000; Sapolsky, 2000a). Glutamate has been implicated in variety of neuropsychiatric disorders including epilepsy, stroke, schizophrenia, Alzheimer's disease, Parkinson's disease, and Huntington's disease (Krystal *et al*, 1999).

3.2.2. NMDA RECEPTOR ACTIVATION

Excitatory amino acid receptors are divided into two broad categories: those containing an integral ion channel (ionotropic receptors) and those coupled to G proteins (metabotropic receptors). The ionotropic receptors are currently subdivided into three main types viz., N-methyl-D-aspartate (NMDA), DL- α -amino-3-hydroxy-5-methyl-4-isoxazolepropanoic acid (AMPA), and kainate receptors (Garthwaite, 1991).

Centrally, activation of the NMDA receptor has been strongly linked with the rapid generation of NO in neurons (McCaslin & Oh, 1995). The NMDA receptor is a ligand gated voltage sensitive ionophore which gates Ca^{2+} -ions, and to a lesser extent Na^{+} - and K^{+} -ions. Stimulation of the receptor and opening of the ionophore channel results in Ca^{2+} -ion entry into the receptive neuron. The Ca^{2+} binds to, and stimulates NOS to convert L-arginine to citrulline and liberate NO (Harkin *et al*, 1999).

The NMDA receptor complex consists of several distinct recognition sites (see fig. 3-4). The primary neurotransmitter site binds L-aspartate, NMDA, and glutamate (Huresco-Levy & Javitt, 1998; Olney, 1990). The other sites include:

- o a cation channel that permits the conduction of calcium and sodium; this Na^{+} -/ Ca^{2+} -ion channel has a much higher Ca^{2+} -conductance than ion channels associated with other excitatory amino acid receptor subtypes;

- o a voltage-dependant site that binds magnesium and at resting membrane potential blocks channel conductance;
- o a co-agonist site that binds glycine which facilitates opening of the NMDA ion channel, and phencyclidine (PCP) receptors which are believed to be positioned within this channel and permit PCP agonists to perform an open-channel block;
- o an inhibitory site that binds PCP, ketamine, MK 801 and other non-competitive antagonists, and,
- o an allosteric modulatory site that recognizes polyamines.

There is evidence that Zn^{2+} -ions, acting at a separate site near the mouth of the NMDA ion channel, acts as an inhibitory modulator of channel function (Olney, 1990).

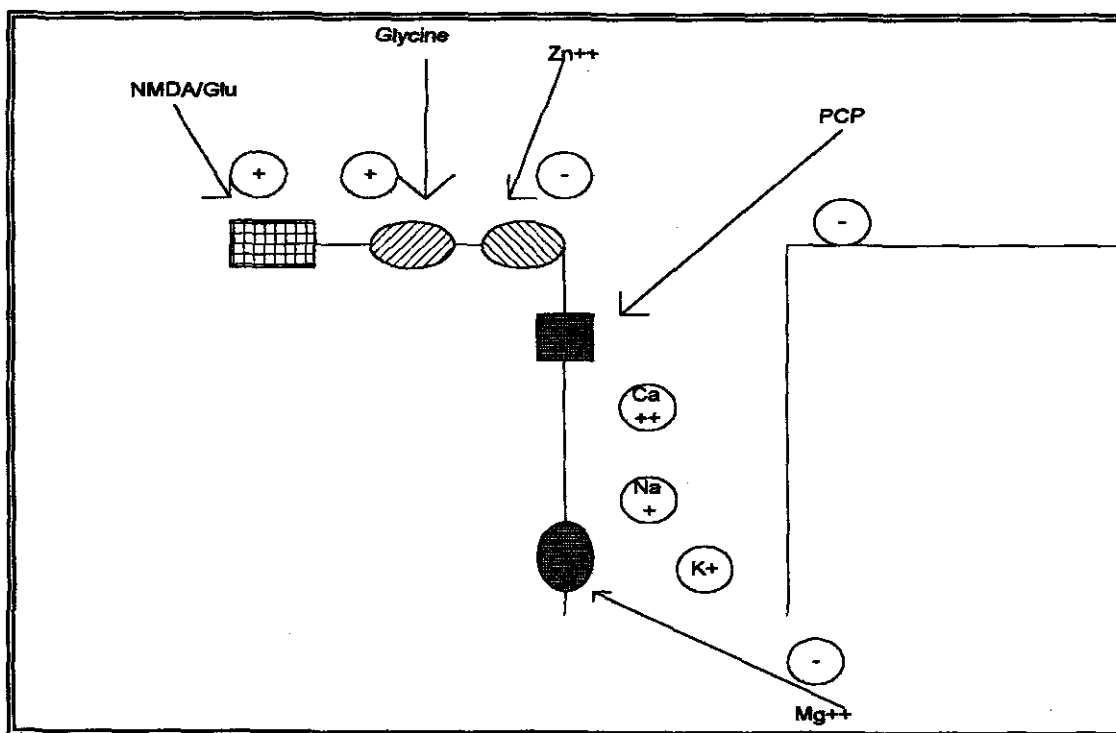

Figure 3-4 A schematic depiction of the various components comprising the NMDA receptor ionophore complex. Recent evidence suggests that endogenous transmitter (e.g. glutamate or aspartate), released from presynaptic axon terminals, activates NMDA receptors on postsynaptic dendrosomal membranes, which results in opening of a Na^+ / Ca^{++} ion channel. Glycine, acting at strychnine insensitive receptors that are co-localized with NMDA receptors, facilitates opening of this channel, whereas PCP, Zn^{++} and Mg^{++} , each acting at separate

sites and presumably by separate mechanisms, are antagonists of channel function (Olney, 1990).

Although the NMDA receptors allow permeability to both sodium and potassium ions like the non-NMDA receptors, NMDA receptors permit only a pronounced calcium influx, and operate over a much slower time scale. A unique feature of NMDA receptors is that their channels require the binding of glutamate and simultaneous local membrane depolarization in order to be activated, as the receptors are blocked in a voltage dependant manner by physiological concentrations of magnesium. Thus, current flow through open unblocked channels occurs only when presynaptic transmitter, glutamate, is combined with postsynaptic depolarisation. In addition, the channel is able to function efficiently only in the presence of glycine, which functions as an obligatory NMDA receptor co-agonist (Huresco-Levy & Javitt, 1998).

3.2.2.1. THE NMDA RECEPTOR AND EXCITOTOXICITY

It was originally believed that activation of the NMDA receptor during glutamate excess was necessary for excitotoxicity (Sapolsky, 2000a). This gave rise to an optimism that pharmacologic inhibition of NMDA receptors would protect dramatically against insults.

Pharmacologic inhibition of NMDA receptors did however not prove to be neuroprotective. The reason for this is that the conductance of NMDA receptors is often inhibited at times when glutamate levels are at their highest. It is known that the NMDA receptor is constrained by numerous negative feedback loops, e.g. calcium excess during insults lead to generation of nitric oxide, which can nitrosylate the NMDA receptor, thereby decreasing its activity (Sapolsky, 2000a).

NMDA receptor densities were also found to be altered in excitotoxic states. It has been hypothesized that elevated extracellular glutamate might down-regulate or alter the NMDA receptor density in order to decrease sensitivity to excess glutamate (Naskar & Dreyer, 2001). Thus, glutamatergic insults set in motion events that act protectively to decrease NMDA receptor sensitivity. The NMDA receptor is thus often far from its most responsive precisely during times when synaptic

glutamate concentrations are at their highest (Sapolsky, 2000a). This may explain why NMDA receptor antagonists have proven to be less protective against some insults than anticipated.

There may be factors that bias toward NMDA receptor-mediated neuron death because of the phenomenon of weak excitotoxicity, where abnormal glutamate exposure increases NMDA receptor sensitivity such that subsequent exposure to even normal levels of glutamate can prove neurotoxic (Sapolsky, 2000a).

An important finding regarding NMDA receptor activation is that overstimulation of NMDA receptors has been found to drastically increase the activation of NOS, resulting in excessive NO production (Naskar & Dreyer, 2001).

3.2.2.2. THE NMDA-RECEPTOR AND LONG TERM POTENTIATION

Perhaps the most characteristic features of PTSD are intertwined learning and memory deficits (Huresco-Levy & Javitt, 1998). Fear conditioning and associative memory dysfunctions lead to core PTSD symptoms (Huresco-Levy & Javitt, 1998).

Long-term potentiation (LTP) represents a form of synaptic learning that is known to exist in the hippocampus, striatum, and neocortex, and has been proposed as a cellular model for some forms of learning and memory. In the hippocampus, LTP is shown by dentate gyrus granule cells. In these cells glutamate acts on both AMPA and NMDA receptors (Vallance & Collier, 1994).

LTP is a prolonged increase in the size of postsynaptic response to a presynaptic stimulus of given strength. Activation of NMDA receptors are obligatory for the induction of the type of LTP that occurs in the hippocampus CA1 region. LTP is initiated by calcium flow through open, unblocked NMDA channels and leads, ultimately, to alterations in the strength of interneuronal synaptic connectivity. Relatively strong activation of NMDA receptors is required for LTP initiation while lesser degrees of activation may lead to other forms of synaptic alteration. NMDA receptors, at resting membrane potentials, are normally blocked by Mg^{2+} -ions. Thus, activation of NMDA receptors requires not only binding of synaptically

released glutamate, but simultaneous depolarization of the postsynaptic membrane (Bliss & Collinridge, 1993; Bloom, 2001; Huresco-Levy & Javitt, 1998).

NMDA-receptor activation may lead to persistent alteration in the strength of synaptic connectivity between neurons via LTP. Important evidence supports the role of NMDA receptors in conditioned fear responses, spatial learning, and LTP (Huresco-Levy & Javitt, 1998). Many PTSD patients exhibit increased startle response, an abnormality generally not reported in other psychiatric disorders. LTP in the amygdala may be related to the encoding of the traumatic memories so vividly associated with e.g. the abnormal startle response (Huresco-Levy & Javitt, 1998). Stress is well known to modulate hippocampal long-term potentiation as well as learning and memory (Kim & Diamond, 2002).

Activation of the NMDA receptors in the hippocampal CA1 region will cause a long-lasting (100 millisecond) Ca^{2+} -ion influx. Influx of Ca^{2+} -ions, in the presence of calmodulin, activates NOS leading to subsequent NO formation (Vallance & Collier, 1994).

3.2.3. NITRIC OXIDE SYNTHASE

Nitric oxide is synthesized by the nitric oxide synthase (NOS) enzymes. These enzymes catalyse the 5-electron oxidation of L-arginine and produce L-citrulline and NO (Vallance & Collier, 1994).

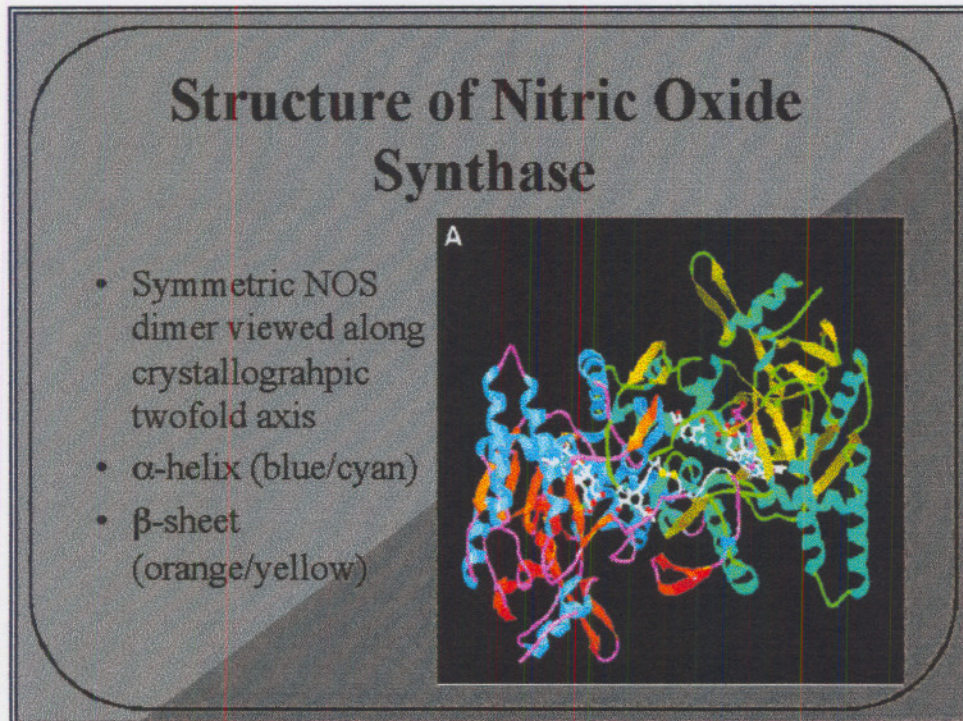

Figure 3-5 The enzymatic structure of nitric oxide synthase (Rousseau, 2003).

Nerves containing NOS are distributed throughout the brain. They are most common in the cerebellum, superior and inferior colliculi, and the granule cell layer of the olfactory bulb, but also occur in the cerebral cortex, hippocampus, posterior pituitary, and autonomic fibres in the retina (Vallance & Collier, 1994).

Three different subtypes of NOS are distinguished. Two constitutive calcium-dependant forms, one discovered in endothelial cells called eNOS, the other present in neuronal cells, known as nNOS. The third subtype is an inducible calcium-independent enzyme, especially present in the macrophages, called iNOS (Forsterman *et al*, 1995).

nNOS and eNOS are expressed only by certain cell types, while most cells are capable of expressing iNOS after stimulation by cytokines. In certain neurons,

nNOS seem to be co-localized with other neurotransmitter synthesizing enzymes (Forsterman *et al*, 1995).

All NOS isoforms are dependant on NADPH (β -nicotinamide adenine dinucleotide phosphate) and calmodulin. In iNOS, calmodulin is present in a tightly bound form, thus iNOS produces NO in a sustained manner in the presence of adequate substrate (Geller & Billiar, 1998; Marletta, 1993; Stuehr, 1997). Ca^{2+} -calmodulin binds to the constitutive enzyme in a reversible manner, but binds irreversibly to the inducible enzyme, so that neurons and endothelial cells, containing the constitutive enzyme produce receptor-regulated pulses of NO, while the inducible enzyme in macrophages and microglia produces sustained levels of NO that are not regulated by receptors (McCaslin & Oh, 1995).

The constitutive isoforms in neuronal and endothelial cells are always present. These NOS isoforms are inactive until intracellular calcium levels increase, the calcium binding protein, calmodulin, binds to calcium, and the calcium-calmodulin complex binds to and activates NOS. The constitutive NOS isoforms then synthesize small amounts of NO until calcium levels decrease. This intermittent production of small amount of NO transmits signals (Lowenstein *et al*, 1994). In contrast, the inducible NOS isoform is normally absent, but when cells are activated by specific cytokines, an inducible NOS isoform is produced. Once produced, it always synthesizes large amounts of NO. Induced NOS is transcriptionally regulated, thus no extracellular calcium is needed. The continuous production of large amount of NO kills or inhibits pathogens (Lowenstein *et al*, 1994).

NOS is a homodimeric enzyme that contains a maximum of one FAD (flavin adenine nucleotide), FMN (flavin mononucleotide), haem, and tetrahydrobiopterin (BH₄), per subunit. A subunit is composed of a reductase domain that contains the binding sites for NADPH and flavins, and an oxygenase domain that contains the binding sites for haem, L-arginine and BH₄. A calmodulin binding site is located between the two domains. Electrons provided by NADPH are transferred in a linear sequence, first entering the NOS flavins and then passing across the domains to the haem iron. Reduction of the NOS haem iron enables it to bind oxygen and catalyze NO synthesis (Dawson & Dawson, 1995; Lowenstein *et al*, 1994; McCaslin & Oh, 1995).

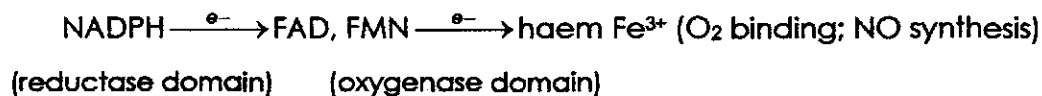

Figure 3-8 Electron transfer in NO-synthesis.

The NOS enzyme requires a number of cofactors, 1 mole for each mole of NOS: FMN, FAD, iron protoporphyrin IX (haem), calmodulin and BH₄ (McCaslin & Oh, 1995). BH₄, an electron transferring cofactor in NO synthesis, may facilitate L-arginine binding through the stabilization of the enzyme. NOS was recently found to contain haem, which reacts with carbon monoxide (CO) and NO, to inhibit purified NOS. Thus, NO may exert negative feedback inhibition by directly inhibiting NOS (Dawson & Dawson, 1995). NO inhibits enzyme activity in a negative feedback loop, while O₂ stimulates enzyme activity (McCaslin & Oh, 1995).

The co-factor calmodulin mediates flavin to haem electron transfer. Calmodulin also stimulates NOS in the absence of L-arginine, the substrate for NOS (Stuehr *et al*, 1995).

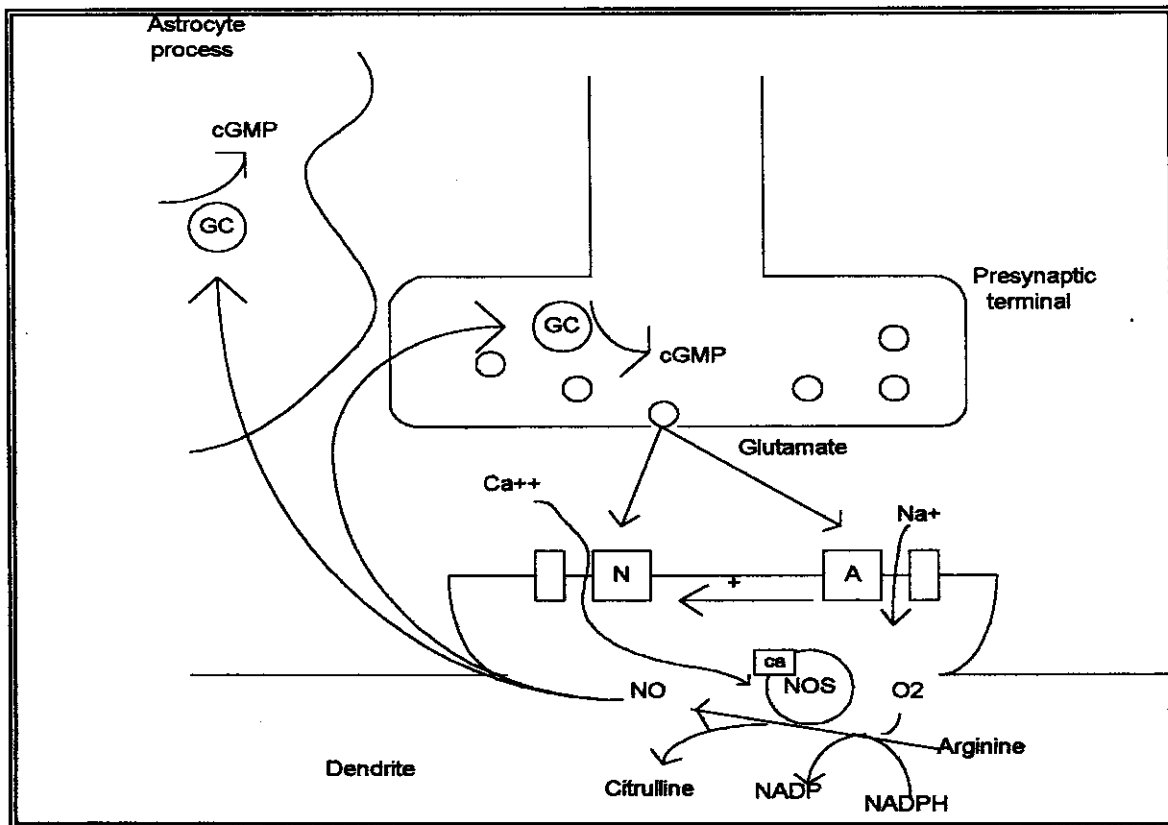

Figure 3-9 Schematic presentation for the operation of the NO system in the CNS. Glutamate released from the presynaptic terminal acts upon NMDA (N) and AMPA (A) receptors. When the postsynaptic membrane is sufficiently depolarised (for example by sustained AMPA receptor activation) the magnesium (Mg^{++}) block of the NMDA channel is reduced, Ca^{++} enters and, via calmodulin (cm), activates NO synthase. The NO formed diffuses out to neighbouring astrocyte fibres and / or to the presynaptic terminals, where it activates guanylate cyclase (GC) (Garthwaite, 1991).

Soluble nNOS requires NADPH as a cofactor and forms citrulline as a co-product. This reaction is highly dependant on calcium in physiologically relevant concentrations, being virtually inactive at normal resting cytosolic free calcium levels ($\sim 50\text{nm}$) and maximally active at $0.4 - 1\mu\text{m}$ calcium. The enzyme activity shows an absolute requirement for calmodulin, hence its calcium dependence (Garthwaite, 1991).

3.4. PHYSIOLOGICAL EFFECTS OF NO

NO is synthesized in neurons in the central nervous system, where it acts as a neuromediator with many physiological functions, including the formation of memory, coordination between neuronal activity and blood flow, and modulation of pain (Garthwaite, 1991; Moncada *et al*, 1997). Though NO-producing cells are scarcely spread in many tissues, the NO release may influence neurons in a widely extended area. The selectivity of this messenger is achieved by NO-receptive characteristics of cell components in certain cells, thus being target cells of NO (Prast & Philippu, 2001).

NO's ability to increase cyclic GMP concentration strongly suggests that NO is involved in many important neurological functions and pathophysiological processes occurring within the central nervous system (Almeida *et al*, 1998; Bolanos *et al*, 1997).

3.4.1. NO AS NEUROTRANSMITTER

NO is an unconventional messenger molecule that either serves to relay information about postsynaptic NMDA receptor activation to neighbouring neuronal and / or glial cells, or is released from nerve fibres on to target cells (Garthwaite, 1991).

Most molecules that transmit signals between cells, such as hormones, neurotransmitters, and growth factors, act through specific protein receptors that are often associated with the plasma membrane. In contrast, NO diffuses out of the cell that generates it and into target cells, where it interacts with specific molecular targets. The best-characterised receptor of NO is iron, contained in certain proteins as a haem group, or as an iron-sulphur complex. NO exerts some effects by binding to iron-containing enzymes, and either activating or inactivating the enzymes (Lowenstein *et al*, 1994).

3.4.2. NO AND cGMP

The main target for NO seems to be soluble guanylate cyclase (Dawson & Dawson, 1995). In the central nervous system, the excitatory amino acid, glutamate increases cGMP. This rise in cGMP occurs after activation of the NMDA subtype of glutamate receptor. Increased levels of cGMP do not take place in the neurons directly stimulated by the glutamate receptor agonists, but in other due to the messenger molecule, NO (Ignarro, 1991; Southam & Garthwaite, 1996).

NOS catalyses the formation of cyclic guanosine monophosphate (cGMP) from guanosine triphosphate (Garthwaite, 1991; Harkin *et al*, 1999; Vallance & Collier, 1994). Two major classes of guanylyl cyclase are known to exist, membrane bound and soluble. Soluble forms of guanylyl cyclase are activated by nitric oxide. NO interacts with the haem moiety of soluble guanylate cyclase to activate it, and the rise in cGMP concentrations produces changes in cell function, often by affecting intracellular calcium concentrations (Vallance & Collier, 1994).

Increased levels of cGMP trigger a reduction of calcium concentration by enhancing extrusion of calcium and its sequestration into intracellular stores. The decrease in intracellular calcium concentration is responsible for the NO-mediated relaxation of vascular and nonvascular smooth muscle, inhibition of platelet adherence and aggregation, inhibition of neutrophil chemotaxis, and signal transduction in the central and peripheral nervous system (Cuzzocrea *et al*, 2001; Ignarro, 1991; Moncada *et al*, 1991).

It is through the generation of NO that numerous types of neurotransmitters, including glutamate, acetylcholine, substance P, histamine, and bradykinine are thought to activate guanylyl cyclase and to increase cellular levels of cGMP in the brain and elsewhere (Garthwaite, 1991; Vallance & Collier, 1994).

3.4.3. NO IN THE CENTRAL NERVOUS SYSTEM

In the central nervous system, three major physiological roles for NO have been proposed (Vallance & Collier, 1994):

- a mediator of long-term depression and potentiation, the fundamental mechanisms of memory formation by which neurones “remember” the signals they have received previously;
- a mediator of short-term electrocortical activation, an alerting response important in control of arousal; and
- a modulator of pain perception.

NO has been implicated in LTP in the CA1 area of the hippocampus, where it is suggested that submaximal presynaptic stimulation induces NO release from the postsynapse, which then signals back to the presynaptic terminal to increase neurotransmitter release and the postsynaptic response, resulting in overall strengthening of the synaptic connection (Schmidt & Walter, 1994).

NO has been implicated in the primary transduction processes of several sensory modalities, including adaptive regulation of visual and olfactory signalling and possibly pain (Schmidt & Walter, 1994).

NO is involved in a wide range of physiological and behavioural functions in the brain, and has also been implicated in a number of pathological neural conditions. Nitric oxide has been reported to play a role in neuronal development (Garthwaite, 1991), thermoregulation (Simon, 1998), nociception (Crosby, *et al*, 1995), learning and memory (Iga *et al*, 1993), fear, anxiety and defence behaviour (Faria *et al*, 1997), seizures (Buisson *et al*, 1993a), and neurotoxicity (Buisson *et al*, 1993b; Verrecchia *et al*, 1994).

3.4.4. DIVERSE EFFECTS OF NO

The synthesis of NO by vascular endothelium is responsible for the vasodilator tone which is essential for the regulation of blood pressure. In the periphery, there is a widespread network of nerves, previously recognized as nonadrenergic and noncholinergic, that operate through a NO-dependant mechanism to mediate some forms of neurogenic vasodilatation and regulate various gastrointestinal,

respiratory, and genitourinary tract functions. NO also contributes to the control of platelet aggregation and the regulation of cardiac contractility. These actions are all mediated by the activation of soluble guanylate cyclase and the consequent increase in the concentration of cyclic guanosine monophosphate (GMP) in target cells (Moncada & Higgs, 1993; Vallance & Collier, 1994).

NO is produced in large quantities during host defence and immunologic reactions. Because NO has cytotoxic properties, and is generated by activated macrophages, it is likely to have a role in non-specific immunity (Moncada & Higgs, 1993). NO, synthesized by inducible NOS in activated murine macrophages, is an important host defence mechanism. NO regulates lymphocyte function and may have a role in inhibiting certain subsets of T-helper cells. Lymphocytes and neutrophils also synthesize and release NO, although its role in the normal functioning of these cells is unknown. NO contributes to the inflammatory response. Vasodilatation may be mediated by inflammatory mediators stimulating endothelial NOS, or by induction of macrophage isoforms in endothelium, smooth muscle, and inflammatory cells in the vessel wall. The NO so produced might contribute to tissue leakage and damage (Vallance & Collier, 1994).

Evidence is accumulating that NO contributes to certain physiological changes that occur during pregnancy. Animal studies suggest that there is an increased expression of NOS during pregnancy and excretion of nitrite and nitrate is raised during this time. The vasodilatation and fall in blood pressure that occur in pregnancy may be partly due to NO, and NO synthesized in the uterus may prevent uterine contraction (Vallance & Collier, 1994).

Arginine has been used to stimulate the release of growth hormone, insulin, pancreatic polypeptide, and other hormones. NO has also been proposed to have a role in regulating renin production and sodium homeostasis in the kidney (Vallance & Collier, 1994).

3.5. NO: NEUROTOXICITY VS. NEUROPROTECTION

Conflicting biological roles have been described for NO. NO may possess both neurodestructive and neuroprotective properties, depending on the immediate biological chemistry (Dawson & Dawson, 1995; McCaslin & Oh, 1995). NO can react with complex carrier molecules and be delivered to target molecules where NO may be donated in the oxidized or reduced forms (Dawson & Dawson, 1996). NO[•] is neurodestructive, while NO⁺ can be neuroprotective or neurodestructive, depending on the proteins targeted (Dawson & Dawson, 1995). All three valence states may exist in the brain and are potentially responsible for some of the conflicting attributes to NO (Dawson & Dawson, 1996).

3.5.1. NO'S ROLE IN NEUROPROTECTION

3.5.1.1. THE EFFECT OF NO ON NOS

Although NO is implicated in a variety of neurodegenerative disorders, excessive NO is thought to inhibit its own synthesis and therefore the neurotransmission process (Asseury *et al*, 1993; ; Dawson & Dawson, 1996; Rogers & Ignarro, 1992; Stuehr *et al*, 1995), thus implying a possible neuroprotective role for NO. Preservation of NO causes further inhibition of NO synthesis, whereas destruction of NO causes an increase in NOS activity (Griscavage *et al*, 1995).

Evidence for the mechanism by which NO inhibits NOS, indicates that a selective binding site for NO on the enzyme protein could serve to modulate its catalytic activity. nNOS and eNOS are more sensitive than iNOS to the inhibitory action of NO (Griscavage *et al*, 1995). This inhibition is reversible (Rogers & Ignarro, 1992).

Concomitant generation of superoxide anion by the same or adjacent cells could however, result in a diminished negative feedback effect because of the rapid reaction between NO and superoxide anion to form peroxynitrite, which would result in enhanced cytotoxicity (Griscavage *et al*, 1995; Rogers & Ignarro, 1992).

3.5.1.2. THE EFFECT OF NO ON THE NMDA RECEPTOR

There is evidence that the key receptor inducing the synthesis of NO is also downregulated by NO in a negative feedback loop. NO appears to downregulate the NMDA receptor by an S-nitrosylation at the redox-sensitive site on the receptor, thus exerting a neuroprotective function (McCaslin & Oh, 1995).

NO regulates NMDA receptor activity in a biphasic manner playing both a positive (via activation of guanylyl cyclase) and negative (via feedback effects on the NMDA receptor resulting in decreased NMDA receptor mediated events) role. Such mechanisms may explain why so many contradictory results have been found suggesting that NO either facilitates or inhibits NMDA receptor mediated events such as LTP, seizures, nociception, neurotoxicity, and anxiolysis (Harkin *et al*, 1999).

3.5.1.3. NOS CONTAINING NEURONS

NOS containing neurons have been found to be resistant to NO-induced neurotoxicity. This might be due to rapid diffusion of NO away from NOS-containing neurons along a concentration gradient in a manner that prevents the generating neurons from encountering excessive concentrations of NO (Dawson & Dawson, 1995).

NOS-containing neurons within the striatum were have also been found to be enriched in manganese superoxide dismutase and this may prevent the local formation of toxic peroxynitrite, rendering NOS neurons resistant to the toxic actions of NO (Dawson & Dawson, 1995).

3.5.2. NO AND NEUROTOXICITY

Under certain circumstances NO may become neurotoxic, despite its many diverse and important physiological functions (Dawson & Dawson, 1996). There is an increasing body of evidence to suggest that excitotoxicity i.e. neurotoxicity due to excessive exposure of neurons to glutamate, is at least partially NO-mediated (Dawson *et al*, 1991; Dawson *et al*, 1993; Dawson & Dawson, 1996; Scultz *et al*, 1995).

3.5.2.1. NO AND PEROXYNITRITE

Simultaneous generation of NO and O_2^- favours the production of a toxic reaction product, peroxynitrite anion, and this product may account for some of the deleterious effects associated with NO production (Cuzzocrea *et al*, 2001; Schultz *et al*, 1995). Although overstimulation of the known physiologic functions of NO could result in or contribute to neurotoxicity, most of the cytotoxic pathways activated following overproduction of NO are more efficiently stimulated by ONOO⁻, the reaction product of NO and O_2^- (Schultz *et al*, 1995).

The reaction between NO and O_2^- occurs at an extremely fast rate of 6.7×10^9 / M per second, and outcompetes superoxide dismutase, an antioxidant enzyme, for the substrate superoxide (Schultz *et al*, 1995).

Peroxynitrite formed from the reaction between NO and O_2^- , is a highly reactive molecule, a potent oxidizing agent known to initiate lipid peroxidation in biological membranes, hydroxylation and nitration of aromatic amino acid residues, and sulphhydryl oxidation of proteins (Schultz *et al*, 1995). Peroxynitrite can damage or deplete a number of vital components e.g. DNA by strand scission, lipids by peroxidation, aconitase, and antioxidant availability (Cuzzocrea, 2001). The resulting oxidative stress may cause cell death and tissue damage that characterize a number of human disease states, among them neurological disorders and stroke, inflammatory bowel disease, arthritis, toxic shock and acute reperfusion injuries (Cuzzocrea *et al*, 2001; Rogers & Ignarro, 1992).

It is possible that other radicals besides NO contribute to some of the toxicity that results from activation of glutamate receptors (McCaslin & Oh, 1995).

3.5.2.2. MECHANISM OF NO-INDUCED NEUROTOXICITY

The molecular mechanism explaining neuronal cell death, following NO exposure, is still a matter of debate. It seems however a consensus that DNA damage, lipid peroxidation, and energy depletion may contribute to such neurotoxicity (see fig. 3-11).

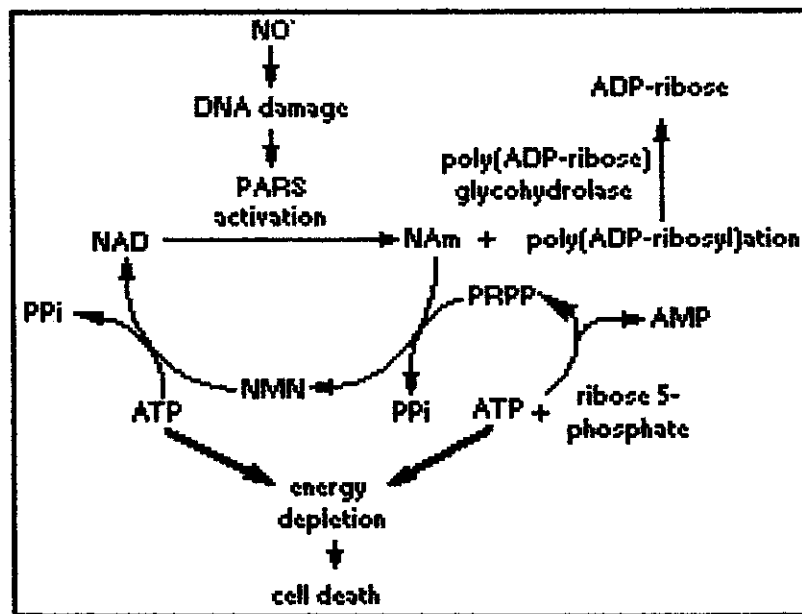

Figure 3-10 Mechanism of NO-mediated neurotoxicity. DNA damaged by NO activates Poly (ADP-ribose), which depletes cells of NAD by poly-ADP-ribosylating nuclear proteins. Poly (ADP-ribose) (PARS) is rapidly degraded by poly (ADP-ribose) glycohydrolase. This futile cycle continues during the prolonged PARS activation. It takes an equivalent of four ATP's to resynthesize NAD from nicotinamide (Nam) via nicotinamide mononucleotide (NMN), a reaction that requires phosphoribosyl pyrophosphate (PRPP) and ATP. The depletion of energy ultimately leads to cell death (Snyder & Dawson, 2003).

Mitochondrial dysfunction may be a mechanism for the NO-mediated neurotoxicity. There is strong evidence that NO reacts with nonhaem iron, for example iron-sulphur (Fe-S) clusters. In contrast to the reaction of NO with haem iron, which is reversible, the reaction of NO with iron-sulphur clusters often results in the destruction of the cluster. This may be an important part of the NO-toxicity as several key enzymes, such as mitochondrial aconitase and complex I and II of the mitochondrial electron transport chain, contain iron-sulphur clusters. NO was recently shown to influence iron-metabolism at the post-transcriptional level by augmenting the iron-responsive element binding activity of the iron-responsive element binding protein. Reaction of NO with the iron-sulphur cluster stimulates messenger RNA binding and depresses cytosolic aconitase activity. NO may inhibit DNA synthesis through binding to the nonhaem iron of ribonucleotide reductase (Schultz *et al*, 1995). Mitochondrial complexes II-III and IV and succinate dehydrogenase are damaged by NO exposure. Inhibition of these

enzymes appears irreversible. Mitochondrial damage at the level of complexes II-III and IV may also occur in neurones because exposure of cultured neurones to peroxynitrate results in apparently irreversible damage to these components of the respiratory chain. Such damage appeared to precede cell death. There is tissue-specific differential susceptibility of mitochondria to peroxynitrite. Within the brain there may also be a differential susceptibility of different cell types to NO. The factors that are responsible for this might include the inner mitochondrial membrane lipid composition and/or intracellular antioxidant defence systems, such as superoxide dismutase activity and glutathione concentration (Bolanos *et al*, 1997).

NO has been shown to deplete intracellular glutathione levels through the formation of intracellular S-nitrosoglutathione. This depletion of intracellular glutathione renders cells vulnerable to subsequent oxidative stress, which may occur through peroxynitrite production (Schultz *et al*, 1995). The intracellular concentration of glutathione following peroxynitrite exposure has been shown to be dramatically decreased in neurones, but not in astrocytes. Further support for a key role for glutathione in protecting against peroxynitrite came from studies in astrocytes that revealed mitochondrial damage and cell death only in glutathione-depleted astrocytes exposed to peroxynitrite. Cellular glutathione may play an important role in the NO-mediated neurotoxicity (Bolanos *et al*, 1997).

3.5.2.3. ADDITIONAL EXPLANATIONS FOR NO-MEDIATED ENERGY DEPLETION AND CYTOTOXICITY.

DNA damage occurs after NO production through nucleotide base deamination. DNA damaged by NO activates the nuclear enzyme poly (ADP ribose) synthase (PARS), which may impair energy metabolism and energy-dependant processes by decreasing intracellular levels of NAD and ATP (see fig 3-11). Because NO poisons the mitochondrial electron transport chain as well, PARS activation can lead to rapid depletion of energy stores. The inhibition of glyceraldehyded-3-phosphate dehydrogenase by NO-mediated ADP-ribosylation may have detrimental consequences. This enzyme catalyses the first step in both glycolysis and the hexose monophosphate shunt and is important for NADP⁺ synthesis and

the maintenance of intracellular reduced glutathione levels (Schultz *et al*, 1995). NO may mediate excitotoxicity by increasing the activity of poly (ADP-ribose) synthetase, a nuclear enzyme that synthesizes poly- (ADP-ribose) from NAD⁺, thus potentially lowering cellular energy levels (Bolanos *et al*, 1997).

3.6. SUMMARY

It is clear that NO is an important regulator of several physiological functions. However, under certain circumstances of excessive formation, NO is emerging as an important mediator of pathological nervous tissue damage. The molecular mechanism explaining neuronal cell death following NO exposure is still a matter of debate, but NO is not the sole mediator in these neurotoxic processes. Excessive glutamate receptor stimulation may lead to neuronal death through a mechanism implicating synthesis of NO. Conflicting biological roles have been described for NO depending on the biological chemistry: NO[•] is neurodestructive, while NO⁺ can be neuroprotective or neurodestructive.

Understanding the conflicting role of NO in pathological processes will hopefully lead to the development of selective therapeutic agents, and to a better understanding of basic processes underlying normal and pathological neuronal functions.

4. EXPERIMENTAL DESIGN

Approval for this study was obtained from the Ethics Committee (Medical; Evaluation Sub-committee for Experimental Animals) of the Potchefstroom University for C.H.E. Evaluation considerations were based on "Guidelines on Ethics for Medical Research" Revised Edition, 1993, South African Medical Research Council.

4.1. EXPERIMENTAL CONDITIONS AND TREATMENT OF RATS

Young adult male Sprague-Dawley rats weighing 150 - 180g were obtained from the Animal Research Center, P.U. for C.H.E. The animals were housed under controlled laboratory conditions at a temperature of $21 \pm 0.5^{\circ}\text{C}$, and a relative humidity of $50 \pm 5\%$. Full spectrum white light with an intensity of 350-400 lux, 1 meter above the ground, was used to give a 12-hour light/dark cycle. Air exchange was maintained at 20 times per hour. Free access to food (standard Epol[®] rat cubes) and water was allowed.

4.1.1. ANIMAL MODEL OF PTSD

The (TDS)-model (Harvey *et al*, 2003), as adapted from Liberzon (1997), was implemented in this study to induce PTSD-like sequelae in Sprague-Dawley rats (Harvey *et al*, 2003; par.2.5.).

In this animal model, rats were exposed to a single session of prolonged stress, followed by a stress-free interval of 6 days. On the seventh day they were re-exposed to a single stressor. PTSD develops in two phases, firstly through exposure to the trauma or unconditioned stimulus, and secondly, through a conditioned stimulus (a physical or mental reminder of the trauma) (Kaplan *et al*, 1994). In the TDS-model the conditioned stimulus or reminder of the trauma was re-exposure of animals to one of the acute stressors, in this case the forced swimming test. The recall stressor is important in significantly altering the physiological and behavioral

response of the animals.

Exposure of experimental animals to TDS stressors was always conducted between 8 and 11 in the morning. The acute stressors the animals were exposed to on day 1 of the TDS procedure were the following:

- Restraint for 2 hours in a restrainer (height: 5cm; width: 7.5cm; length: 10-18cm), where no movement was allowed.
- This was followed immediately by a forced swim test for 15 minutes in 24°C water. This part of the test was carried out according to the Porsolt model (Porsolt *et al*, 1977; 1978). In short, animals were forced to swim in a vertical Perspex cylinder (height: 40cm; radius: 18cm) filled with water to a height of 30cm, from which they were unable to escape.
- Animals were allowed to recuperate for 15 minutes and were then exposed to 4% halothane vapors until loss of consciousness. Inhalation anesthetics inhibit the nitric oxide soluble guanylate cyclase signaling pathway in vascular and neuronal tissues, and it has been proposed that this inhibition is due to several mechanisms, which include a direct inhibition of NOS. It has however been found that the effects of inhalation anesthetics on NO synthesis in rat and bovine brains and in vascular endothelial cells are not due to their direct interaction with NOS (Rengasamy, 1995).

The animals were then returned to their home cages and left undisturbed for 7 days. On the 7th day they were re-exposed to a single stressor (the 15 minute forced swim test). The animals were not exposed to any further stressors.

Determination of the different parameters assayed in this study was done at different time intervals during and after exposure to the TDS-model. A group of experimental animals were decapitated within 1 hour after exposure to the initial stressor to determine the influence of acute stress on the different parameters assayed. This group will be referred to as the Acute group. Another group of animals was decapitated within 1-2 hours after exposure to the re-stress session, once again to determine the effect of stress-exposure on the different parameters, and to compare the influence of the re-stress session with the influence of exposure to the acute stressors. This group will be referred to as 0

days ps. Finally, a group of animals was decapitated 21 days after exposure to the re-stress session. This group will be referred to as 21 days ps. The last time interval was chosen based on results from previous studies that measured PTSD-like effects induced after exposure to an animal model for up to 21 days after stress-exposure (Adamec *et al.*, 1999; Antelman *et al.*, 1988; 1989a; 1989b). This represents an important phenomenological quality of an animal model of PTSD, i.e. persistence of behavioural and biochemical sequelae.

4.1.1.1. VALIDATION OF THE TDS-MODEL

Validation of the TDS-model under local laboratory conditions was necessary, in order to evaluate the efficacy of the model itself in the induction of PTSD-like sequelae, as well as determining the possible effects of inter-laboratory differences and handling of animals on application of the model (Harvey *et al.*, 2003). The model was validated by determining the corticosterone levels in plasma of rats with the Biotrak[®] rat corticosterone [¹²⁵I] assay system (Amersham).

4.1.1.1.1. PLASMA CORTICOSTERONE ASSAY:

This assay is based on the following principles: unlabelled corticosterone and a fixed quantity of [¹²⁵I]-labeled corticosterone competes for a limited number of binding sites on a corticosterone specific antibody. With fixed amounts of antibody and radioactive ligand, the amount of radioactive ligand bound by the antibody will be inversely proportional to the concentration of added non-radioactive ligand. The antibody bound corticosterone is then reacted with the Amerlex-M[®] second antibody reagent which contains the second antibody that is bound to magnetizable polymer particles. Separation of the antibody bound fraction is effected by centrifugation of the Amerlex-M[®] suspension and decantation of the supernatant. Measurement of the radioactivity in the pellet enables the amount of labeled corticosterone in the bound fraction to be calculated. The concentration of unlabelled corticosterone in the sample is then determined by interpolation from a standard curve.

i) Specimen collection and sample preparation:

Blood was collected into tubes containing EDTA. After collection, blood was centrifuged immediately to remove cells, and the plasma was subsequently stored below -70°C . Prior to assay, corticosterone was displaced from cortisol binding globulin in plasma. This was done by heating diluted samples at 60°C in a waterbath for 30 minutes. The samples were then cooled to ambient temperature and assayed. Plasma samples were diluted due to the high corticosterone concentration; this was done by adding $400\mu\text{l}$ of assay buffer.

ii) Assay:

The Biotrak[®] Rat corticosterone [^{125}I] assay system contained the following reagents:

- 0.02M borate pH 7.4 buffer containing 0.1% sodium azide;
- working standards in the following concentrations: 0.078ng, 0.156ng, 0.312ng, 0.625ng, 1.25ng, 2.5ng, 5ng, 10ng and 20ng. The final solution contained corticosterone at a concentration of 400ng/ml;
- anti-corticosterone serum in 0.2M borate buffer, pH 7.4, containing 0.1% sodium azide;
- [^{125}I] corticosterone serum in 0.2M borate buffer, pH 7.4, containing 0.1% sodium azide.

Table 4-1 The radioimmunoassay was carried out as follows:

	Total counts	Non-specific binding	Zero standard	Standards	Samples
Buffer		200 μl	100 μl		
Standard				100 μ	
Sample					100 μ
Antiserum			100 μ	100 μ	100 μ
Tracer	100 μl	100 μ	100 μ	100 μ	100 μ

After addition of all the reagents, the tubes were mixed using a vortex mixer. Thereafter the tubes were covered and incubated at room temperature ($15-30^{\circ}\text{C}$) for 2 hours. $400\mu\text{l}$ of Amerlex-M[®] second antibody was subsequently added to each tube, except the tube used for determination of total counts. The mixtures

were incubated at room temperature for 10 minutes.

After the final incubation, the antibody bound fraction was separated by centrifugation at 1500g for 10 minutes at 4°C.

The radioactivity present in each tube was determined by counting for at least 60 seconds in a Cobra-Autogamma scintillation counter (Packard).

4.1.2. DRUG TREATMENT:

In this study, certain pharmacological interventions were evaluated to determine possible means of inhibiting the induction of PTSD-like sequelae in experimental animals.

Experimental animals were divided into 4 groups, receiving pre-treatment with one of the following drugs: fluoxetine, ketoconazole, 7-nitroindazole or aminoguanidine. Animals received intra-peritoneal injections for a period of 21 days. After 2 weeks of chronic treatment (on day 14 of treatment), the animals in these groups were exposed to the triple stressor as part of subjection to the TDS-model. On the final day of drug treatment (day 21 of treatment, 7 days after exposure to the triple stress) the animals were re-exposed to the forced swimming test, as the final part of the TDS-model.

The animals were left undisturbed for a further period of 21 days. After this drug-free period, animals were decapitated and their hippocampi removed (see par. 4.1.3.)

Animals used in the control group received intra-peritoneal saline injections (0.9% NaCl) for a period of 21 days, thus exposing them to the same type of handling stress as the groups of animals receiving drug treatment.

4.1.2.1. FLUOXETINE:

Fluoxetine (Eli Lilly) is a selective inhibitor of the synaptic serotonin re-uptake process. Selective serotonin inhibitors (SSRI's) potentiate the effect of serotonin that is released by neuronal activity (Sanders-Bush, 1995).

Dose: Animals receiving fluoxetine pre-treatment were divided into two groups: one receiving a dose of 10mg/kg/day and the other group receiving 20mg/kg/day. Fluoxetine was made up in 0.9% NaCl solution (normal saline) and each animal received an intraperitoneal injection of 0.5ml.

Since fluoxetine is indicated in increasing concentrations ranging from 20mg/day up to 60mg/day in patients suffering from PTSD (Connor *et al*, 1999), it was therefore decided to administer fluoxetine at a higher dose to measure the effect on the various parameters studied.

4.1.2.2. AMINO GUANIDINE

Aminoguanidine (Sigma) is equipotent to N^G-monomethyl-L-arginine and N^G-nitro-L-arginine as an inhibitor of iNOS, but it is much less potent as an inhibitor of the constitutive isoforms of NOS (Joly, 1994; Misko, 1993). The IC₅₀ values for inhibition of iNOS and rat nNOS by amino-guanidine are 5.4μM and 160μM respectively, at an arginine concentration of 30μM (Misko, 1993).

Dose: 50mg/kg/day (Sanches *et al*, 2002). Aminoguanidine was made up in 0.9% NaCl solution and each animal was injected with 0.5ml intraperitoneally.

A previous study by Sanches *et al*, 2002, administered aminoguanidine prior to stress-induced fever. The results from this study indicated that this dose was effective for iNOS inhibition, but also safe for chronic treatment.

4.1.2.3. 7-NITROINDAZOLE

7-Nitroindazole (Sigma) acts as a selective inhibitor of nNOS when administered systemically (Moore *et al*, 1993; Moore *et al*, 1993b; Zhang, 1995).

Dose: 12.5mg/kg/day (Nel, 2002). 7-Nitroindazole was made up in dimethyl

sulphoxide (DMSO- Sigma) and injected intraperitoneally in a volume of 0.5ml.

A study in which animals received single injections of 7-nitroindazole, ranging from 0-125mg/kg, found optimum inhibition of nNOS at a dose of 20mg/kg (Connop *et al*, 1994). A very important finding regarding the kinetics of 7-nitroindazole is that this drug does not inhibit nNOS in a dose-dependant fashion, but increasing doses of 7-nitroindazole result in a U-shaped curve of nNOS inhibition: while a dose of 20mg/kg was found to decrease NOS activity by 90% (Connop *et al*, 1994), a dose of 40mg/kg decreased NOS activity by 80% (Connop *et al*, 1996), a single injection of 50mg/kg inhibits NOS activity by only 55% (Yoshida *et al*, 1994), while a dose of 100mg/kg were found to exhibit the same effect as a dose of 20mg/kg, resulting in a 90% reduction of NOS activity (Salter *et al*, 1996).

It is important to note that in these studies, higher doses of 7-nitroindazole were administered acutely, while in our study animals were to be subjected to chronic treatment, therefore it was important to decide on a dose that would be relatively safe over a longer period.

A previous chronic study carried out in our laboratory found that a dose of 12.5mg/kg/day was the highest dose not producing pronounced catalepsia (Nel, 2001). Literature underlines this finding by indicating that a dose as low as 10mg/kg produce marked sedative effects (Volke *et al*, 1997). Ikeda *et al* (1998), found that a dose as low as 5mg/kg, administered chronically, resulted in a significant decrease in NOS-related motor dysfunction and motorneuron degeneration.

In this study, it was therefore decided to administer 7-nitroindazole in a dose of 12.5mg/kg/day. Although this dose is not indicated as producing maximum inhibition of nNOS, lower doses of 7-nitroindazole provided effective inhibition of nNOS (Ikeda *et al*, 1998) and provided a wide margin of safety for chronic treatment regimens.

4.1.2.4. KETOCONAZOLE

Ketoconazole, an imidazole derivative, is a potent inhibitor of gonadal and adrenal steroid synthesis (Cohen *et al*, 2000). Ketoconazole inhibits the synthesis of ergosterol in fungi and of cholesterol in mammalian cells by blocking 14-demethylation of lanosterol. Ketoconazole also interferes with several cytochrome P-450-dependant enzymes involved in steroid synthesis. It has been used successfully as a palliative treatment of Cushing's syndrome due to its ability to lower cortisol production (Cohen *et al*, 2000).

Dose: 24mg/kg (Cohen *et al*, 2000). Ketoconazole was made up in 0.9% NaCl solution and each animal was injected with 0.5ml intraperitoneally.

In a study done by Cohen *et al*, 2000, ketoconazole was found to inhibit glucocorticoid synthesis at this dose.

4.1.3. TISSUE DISSECTION AND STORAGE

Decapitation of experimental animals was constantly performed between 08:30 and 11:00 in the morning. After decapitation, the brains were quickly removed. The hippocampus was subsequently dissected out on ice. Tissues were pooled for the NMDA-receptor binding assay, or placed individually in tubes for determination of NOS activity. It was necessary to pool two hippocampi per analysis to obtain a sufficient concentration of protein for the NMDA receptor binding. The hippocampi were subsequently frozen in with liquid nitrogen and kept at -86°C until analyzed. Control and experimental animals were decapitated in the same way.

4.1.4. DETERMINATION OF PROTEIN CONCENTRATION

The protein concentration in the tissue homogenate was determined by the method of Lowry *et al*, (1951), and was based on the following principles:

A specific volume of the tissue homogenate was added to a solution of Cu²⁺-ions in an alkaline (NaOH) medium. This solution was incubated at room temperature. During the incubation period the Cu²⁺-ions interact with the proteins in the tissue homogenate.

A certain amount of Folin-Ciocalteus reagent was subsequently added to this mixture, and the mixture incubated in a water bath at 50° C. The copper-protein complex acts as an electron donor and reduces the added reagent (poliphosphomolibdene and poliphosphotungsten acid) from yellow to a deeply coloured molibdene and tungsten blue. The concentration of protein is directly proportional to the intensity of the colour, as determined by absorption spectrometry (Lowry et al, 1951),.

The protein assay was carried out as follows:

A series of protein standards was made from bovine serum albumin (BSA) (1mg/ml) in volumes of 10µl, 20µl, 30µl, 40µl, and 50µl. This was used as standard concentrations for the determination of protein concentration in the homogenate sample. The volume of the standard protein concentrations was made up to 1ml with deionized, distilled water.

50µl of the tissue homogenate was added to 950µl deionized, distilled water. The tartrate reagent (1ml) was subsequently added to both standard sequence tissue homogenate.

The tartrate reagent was made up as follows:

10% sodium bicarbonate in 0.5M sodium hydroxide

1% potassium tartrate

5% copper sulphate

After addition of the tartrate reagent, the mixture was incubated for 10 minutes at room temperature for the Cu^{2+} -ions to form a complex with the proteins.

Subsequently, 3ml of Folin-Ciocalteus reagent (Sigma) was added to the mixture. The Folin-Ciocalteus reagent was used in a 1 to 10 dilution with deionized, distilled water. The mixture was incubated for 10 minutes at 50°C in a water bath. The colour change from yellow to blue takes place during this incubation step.

The OD-650 values (optical density at 650nm) were determined in the standard protein concentrations. The absorption spectrum of these standard protein

concentrations was then used to determine the protein concentration of the tissue homogenate.

4.2. ANALYSIS OF NOS ACTIVITY

Methods for the measurement of NO have been described in the literature (Bredt & Snyder, 1990; Bredt & Schmidt, 1996). The assay-method is based on the following principles: radioactive arginine, the substrate for NOS, was added to brain homogenate derived from the hippocampi of Sprague-Dawley rats. This mixture was subsequently incubated. During the incubation NOS converts the arginine precursor to NO and citrulline. After a certain time interval the reaction was terminated by adding a buffer containing EDTA. Thereafter it was washed through a Dowex clean-up column, where the arginine-precursor was separated from the citrulline product. The concentration of radioactive citrulline was determined with a scintillation spectrometer, is an indication of NOS-activity.

NOS catalyzes the formation of equi molar quantities of NO and L-citrulline from L-arginine (Bush *et al*, 1992). The amount of L-citrulline formed is therefore an indication of the amount of NO formed per unit time, as well as the activity of NOS.

4.2.1. CHARACTERIZATION AND DEVELOPMENT OF THE ASSAY METHOD

It was important that the method used in this study be characterized under local laboratory conditions with the aim of ensuring a simple, effective and reliable method for assay of NOS in the hippocampus of rats.

The measurement of enzyme activity is influenced by many factors including substrate and enzyme concentration, pH, temperature and the presence of activators or inhibitors (Wilson, 1986).

4.2.1.1. ISOLATING THE ENZYME

It was important to verify that the radioactivity measured with this assay, was an indication of NOS activity, and not due to chemical reactions occurring during the assay procedures. This was done by determining the activity of NOS in a hippocampus, and subsequently comparing it to the NOS-activity in a brain

sample where the enzyme has been denaturated by heating the tissue at 60°C for 30 minutes in a water bath.

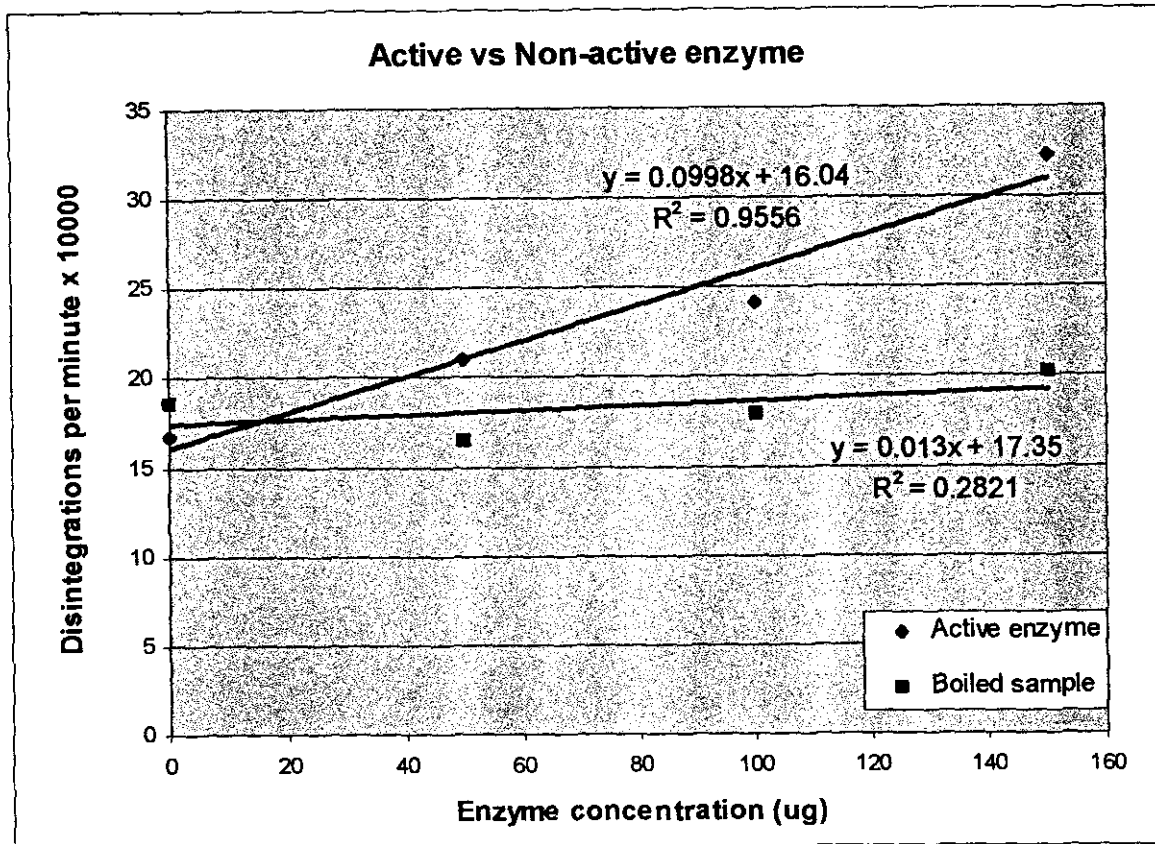

Figure 4-1 Isolation of the NOS-enzyme from the hippocampus.

The results in Figure 4-1 confirmed the activity of NOS in the active sample, compared to the absence of activity as measured in the sample where the enzyme was inactivated by heating, thus confirming that substrate conversion measured in this assay was due to NOS-activity.

4.2.1.2. ENZYME CONCENTRATION

As part of the characterization of the assay, the optimum enzyme concentration to be used in the assay, was determined. This was done by varying the protein concentration in the assay.

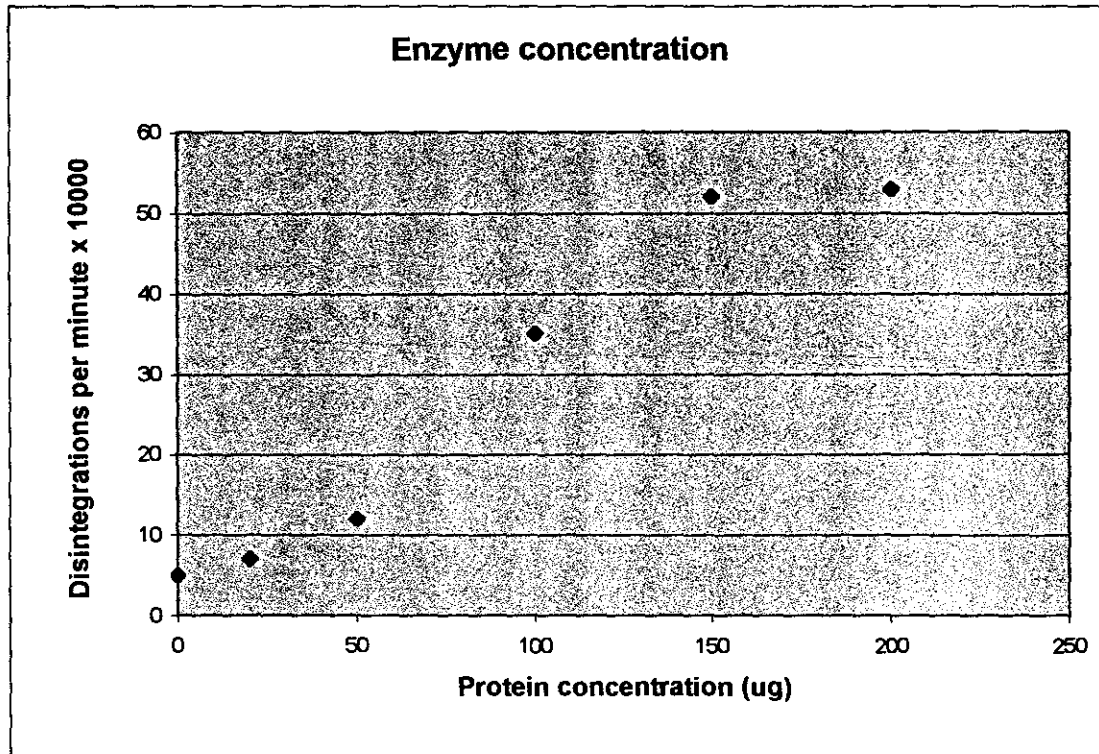

Figure 4-2 Determination of protein concentration.

The assay had to be carried out at an enzyme concentration adequate enough to convert the added substrate to product, but prior to reaching steady state. Characterization assays indicated that the optimal enzyme concentration for this assay would be in a range from 30-50ug protein. Enzyme concentrations above 50ug protein or below 30ug of protein did not yield adequate results for determination of enzyme kinetics. An enzyme concentration of 50ug was thus used throughout the study.

4.2.1.3. pH

Cellular processes are sensitive to pH changes and take place in a medium in which the pH is carefully regulated. The majority of intracellular processes occur at a pH maintained near *in vivo*, in the case of this study, at pH 7.4 (Bredt & Schmidt, 1996). This *in vivo* pH is generally the one at which the various metabolic processes occur at their maximum rate. The control of a virtually constant pH in biological systems is achieved by the actions of efficient buffering systems (see par. 4.2.2.) whose chemical nature is such that they can buffer pH changes due to metabolic processes (Wilson, 1996).

4.2.1.4. TEMPERATURE

The rate of enzyme reaction varies with the temperature according to the Arrhenius equation:

$$\text{rate} = Ae^{-E/Rt}$$

Equation 4-1 A = constant; E = activity in energy (Jm^{-1}); R = gas constant ($8.2 \text{ Jm}^{-1}\text{K}^{-1}$); t = absolute temperature

The equation explains the sensitivity of the enzyme reaction to temperature since the relationship between reaction rate and temperature is exponential. The rate of most enzyme reactions approximately doubles for every 10°C rise in temperature (Q_{10} value). At a temperature characteristic of the enzyme and generally in the region of 40°C - 70°C , the enzyme is denaturated and the enzyme activity is lost. The optimum temperature is time dependant and for this reason is not the one normally chosen to study enzyme activity. Enzyme assays are routinely carried out at 30°C or 37°C (Wilson, 1996).

In this study, the assay for determination of NOS activity was carried out at 37°C . Temperature curves were not performed and this optimum temperature was chosen based on previous literature studies (Bredt & Schmidt, 1996; Wilson, 1996).

4.2.1.5. PRESENCE OF CO-FACTORS

NOS require hearn, calmodulin, FAD, FMN and BH_4 as cofactors, and NADPH and molecular oxygen as co-substrates (see par 3.3.). All of these were obtained from Sigma.

4.2.1.6. SUBSTRATE CONCENTRATION

The K_m -value of an enzyme is an indication of the concentration of the substrate required to saturate the active sites of the enzyme. As the reported range of K_m for the NOS isoenzymes is in the order of $2\text{-}20\mu\text{M}$, appropriate concentrations of arginine for studies of the enzyme kinetics are usually in the range of $0.1 - 100\mu\text{M}$ (Bredt & Schmidt, 1996).

4.2.2. ASSAY:

NOS assays were carried out as follows:

The hippocampi were thawed at room temperature, and homogenized in buffer (25mM Tris, pH 7.2; 1mM EDTA; 1mM EGTA) with a Hendolph-Teflon homogeniser. The homogenate was centrifuged at 10 000xg for 15min with a Beckman-Ultracentrifuge (model L5-40).

The supernatant was decanted and the protein concentration in the supernatant determined by the method of Lowry *et al*, 1951 (see par. 4.1.4.). A substrate concentration series was made up consisting of 50 μ l l-arginine (l-arginine (Sigma) + [³H]-l-arginine (specific activity=24.6 μ Ci; Amersham), 300 μ M) in different concentrations ranging from 0.1 - 100 μ M. 50 μ g of protein was added to each reaction vial. The 50 μ g of protein was made up to a volume of 358.5 μ l (as described in table 4-1).

The following reaction mixture, consisting of co-factors for the activation of the enzymatic reaction, was added to the protein and arginine mixture. The total reaction volume was 500 μ l.

Table 4-1 indicates the volumes and concentrations of the cofactors used in the NOS-assay.

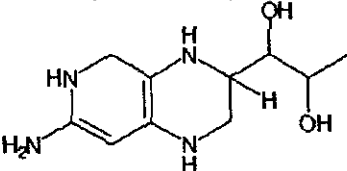
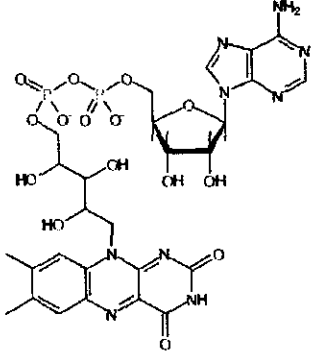
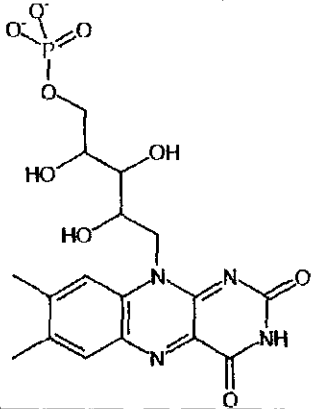
Reagent	Volume	Concentration in 500 μ l
1M Tris pH 7.4	12.5 μ l	25mM
1mM (6R)-5,6,7,8-Tetrahydrobiopterin dihydrochloride (BH ₄) +  4mM DL-dithiothreitol (DTT)	1.5 μ l	3 μ M 12 μ M
0.1mM Flavin adenine dinucleotide disodium (FAD) 	5 μ l	1 μ M
0.1mM Flavin mononucleotide sodium (FMN) 	5 μ l	1 μ M
10mM B-nicotinamide adenine dinucleotide phosphate reduced form tetrasodium (NADPH)	50 μ l	1mM
300 μ M arginine (consisting of 25 μ l l-arginine and 25 μ l [3H] l-arginine)	50 μ l	30 μ M
125mM CaCl ₂	5 μ l	1.25mM
10 μ g/ml Phosphodiesterase 3': 5'-cyclic nucleotide activator from bovine brain (Calmodulin)	12.5 μ l	0.25 μ g/ml
Protein mixture	358.5 μ l	
Total volume	500μl	

Prior to the addition of CaCl_2 , the mixture was pre-incubated for 2min at 37°C . After the pre-incubation period, CaCl_2 was added and the reaction mixture was incubated for a further 15min at 37°C . The enzymatic reaction is dependant on CaCl_2 and only starts after addition of the CaCl_2 .

The reaction was terminated by adding $500\mu\text{l}$ ice-cold buffer (50mM HEPES, pH 5.5; 5mM EDTA).

After the incubation-period, the reaction mixture was loaded onto 1ml of Dowex AG-50W-x8 column that has been pre-equilibrated (3x1ml) with buffer (50mM HEPES, pH 5.5, 5mM EDTA). Dowex (Sigma) is an anion-exchange column used to separate l-citrulline, which is neutral, from l-arginine, which is positively charged (Dawson & Dawson, 1995). The column was washed with the same buffer ($2 \times 500\mu\text{l}$) to wash all of the l-citrulline through. The eluate ($[^3\text{H}]$ -l-citrulline) was caught in scintillation vials (Packard) and 4ml of scintillation fluid (Chemlab) was added. The radioactivity for each assay was counted with a scintillation counter (Packard Tri-carb 4660 scintillation spectrometer).

4.2.3. ANALYSIS OF DATA

The enzyme kinetics was determined using a Linweaver-Burke plot. The V_{max} and K_m values were obtained from this plot. The rate of product formation was determined by subtracting the blank count of $10\mu\text{M}$ $[^3\text{H}]$ -l-arginine from the counts of $10\mu\text{M}$ $[^3\text{H}]$ -l-arginine where enzyme substrate was added.

The mathematical relationship between initial rate of an enzyme reaction and substrate concentration is expressed by the Michaelis-Menten equation:

$$V_0 = \frac{V_{\text{max}} [S]}{k_m + [S]}$$

Equation 4-2 The Michaelis-Menten equation. $[S]$ = substrate concentration; V_{max} = limiting value of V ; K_m = Michaelis constant (Wilson, 1996).

K_m :

- numerically equal to the substrate concentration at which the initial rate is one half of the maximum rate
- has units of molarity
- is independent of enzyme concentration and is characteristic of the system
- values usually in the range 10^{-2} to 10^{-5}

K_m values are important because they enable the concentration of substrate required to saturate the active sites of the enzyme to be calculated.

V_{max} is related to the catalytic rate of the enzyme, which expresses the number of moles of substrate converted to product by one mole of enzyme in one second.

Enzyme catalysed reactions proceed via the formation of an enzyme-substrate complex (ES) in which the substrate is non covalently bound to the active site of the enzyme.

The formation of this complex (ES) is rapid and reversible and is characterised by the dissociation constant K_s of the complex:

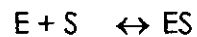

The conversion of bound substrate to product is a slower and rate determining step.

In the simplest situation where the product is formed in a single step and at a rate such that the equilibrium concentration of ES is maintained, it can be shown that the observed K_m is equal to K_s i.e. the Michaelis-Menten equation becomes:

$$V_0 = \frac{V_{max}[S]}{k_s + [S]}$$

Equation 4-3

Whilst the Michaelis-Menten equation can be used to calculate K_m and V_{max} , its use is subject to error due to the difficulty of experimentally measuring initial rates

at high substrate concentrations.

Linear formations of the Michaelis-Menten equation are therefore preferred (Linweaver-Burk)

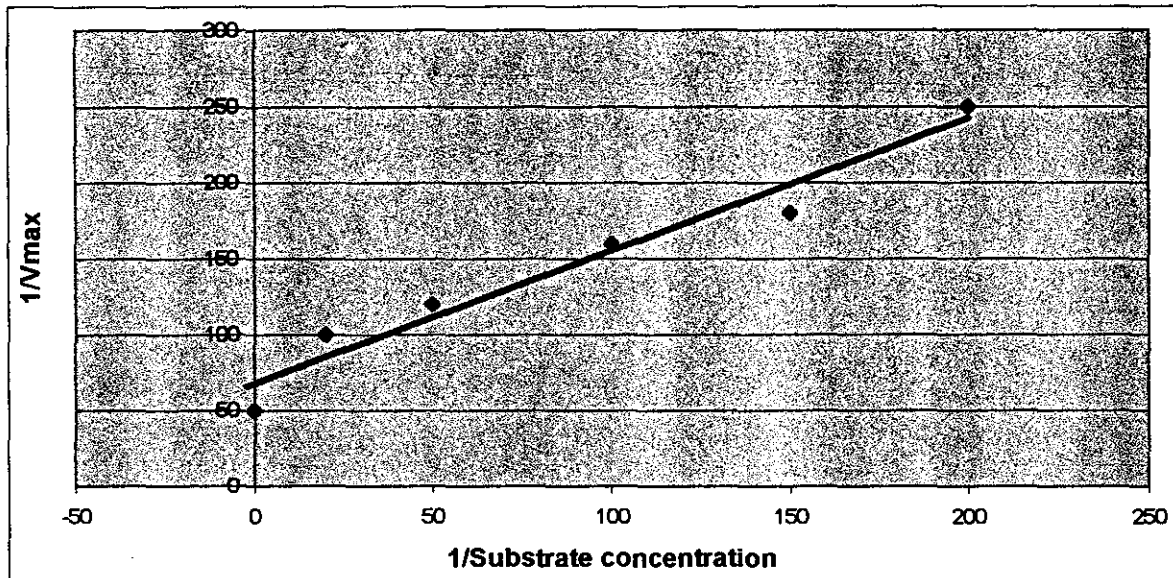

Figure 4-3 An example of a Linweaver-Burke plot that is the linear formation of the Michaelis-Menten equation.

A plot of $\frac{1}{V_0}$ against $\frac{1}{[S]}$ gives a straight line of slope $\frac{K_m}{V_{max}}$ with an intercept on the $\frac{1}{V_0}$ axis of $\frac{1}{V_{max}}$ and an intercept on the $\frac{1}{[S]}$ axis of $\frac{-1}{K_m}$.

The Linweaver-Burke graph was thus used to determine V_{max} and K_m values for NOS-activity in the hippocampus of experimental animals.

4.3. NMDA RECEPTOR BINDING CHARACTERISTICS

The objective of this part of the study was to determine the change, if any, in NMDA receptor density in the hippocampus of animals exposed to the TDS-model, as well as animals receiving pre-treatment with afore mentioned drugs prior to exposure to the TDS-model, subsequently comparing these data to observe possible changes. Determination of NMDA receptor binding was done by radioligand binding techniques.

Radioligand binding studies are based on the following principles:

A chemical with a high affinity for the specific receptor to be measured is marked radioactively with tritium [^3H]. The brain homogenate is incubated with the radioligand at a certain temperature until equilibrium is reached. Equilibrium is the time the specific binding process takes to reach a maximum. The total amount of specific radioligand that binds per milligram of brain sample, gives an indication of receptor density (Enna, 1980).

The method of Andersen *et al*, 1995, with minor adjustments, was used in this study to determine NMDA-receptor binding characteristics.

4.3.1. PREPARATION OF BRAIN HOMOGENATE

Brain samples were obtained as described in par. 4.1.3. Before the assay was carried out, the brain samples were weighed and thawed.

The tissue was subsequently homogenised in 50 volumes of ice-cold HTS buffer (5mM HEPES / 4.5mM Tris buffer) (pH 7.8) with a Brinkman Polytron (setting 6) for 20 seconds, whereafter the homogenate was centrifuged for 20min at 20 000xg and 4°C with a Beckman Ultra centrifuge (model L5-40).

The pellet was re-suspended in HTS buffer and again centrifuged at 20 000xg for 20min at 4°C. The resulting pellet was resuspended in 50 volumes of HTS-buffer. This sample was then centrifuged for 20 minutes at 20 000xg and 4°C. The final pellet was resuspended in 60 volumes HTS buffer. 50 μl of this final suspension was used to determine the protein concentration according to the method of Lowry *et al* (1951).

4.3.2. ASSAY

The incubation mixture for the determination of total binding consisted of 300µl membrane suspension to which 50µl radioactive [³H]-MK 801 was added. 50µl 10µM L-glutamate (L-glutamic acid; Sigma) and 50µl 30µM glycine (Sigma) was added to activate the receptor ion channel . Finally 50µl buffer was added to a final incubation volume of 500µl.

The incubation mixture for the definition of non-specific binding consisted of 300µl membrane suspension, 50µl [³H]-MK 801, 50µl 5µM MK 801 that acts as cold ligand, 50µl 10µM L-glutamate and 50µl 30µM glycine. The total incubation volume was 500µl.

The radioligand (MK 801) was added in 10 concentrations ranging from 0.1-20nM. The assay was consistently carried out in duplicate.

The radioligand was always added last to the incubation mixture. After the radioligand was added, the mixture was mixed thoroughly with a vortex and incubated in a water bath for 1.5 hours at room temperature.

The final step in this assay was the termination of the receptor binding reaction by separating the receptor bound ligand from the free ligand in the incubation mixture. The reaction was terminated by rapid filtration through Whatman GF/B filters pre-soaked in buffer. The filters were subsequently washed twice with 5ml HTS to dispose of free or unbound radioligand. The radioligand that is bound to receptors stays on the filters, while the unbound ligand is washed through the filters.

After the rinsing process was completed the filters were placed in polypropylene tubes (Packard) and 4ml scintillation fluid (Ultra gold XR; Packard) added to each tube for extraction of the radioactivity.

4.3.3. MEASURING OF RADIOACTIVITY

The radioactivity on the filters, thus the bound radioligand, was counted with a Packard Tri-Carb 4660 scintillation spectrometer. The counts per minute (cpm) were converted to disintegrations per minute (dpm). This was done by calculating the extinction coefficient with the use of a standard curve. The standard curve was constituted under the same experimental conditions.

The scintillation spectrometer was directly linked to a computer that calculated the receptor density (B_{max}), as well as the affinity value (K_d), with the Combicept program (Packard, Canberra). The results were given as Scatchard and saturation curves. Receptor density was expressed in fmol/mg protein.

4.4. HPLC ANALYSIS OF GABA IN THE HIPPOCAMPI

Quantification of GABA in the hippocampus of rats was performed by a high-performance liquid chromatography (HPLC) method with electrochemical detection (Donzati & Yamamoto, 1988; Jonker, 2001).

4.4.1. VALIDATION OF METHOD

The described method was validated in terms of its selectivity, linearity and reproducibility in this laboratory (Jonker, 2001). This method was proven to be selective and sensitive enough under our laboratory conditions to detect nanomolar quantities of GABA (Jonker, 2001).

4.4.2. MOBILE PHASE

The mobile phase comprised of 0.1M (Na_2HPO_4), 0.13M disodium ethylenediamine tetra-acetic acid (Na_2EDTA), and 28% methanol. The pH of the buffer was set between 6.0 – 6.4 with the addition of 85% phosphoric acid.

This solution was filtered through a 0.22 μm membrane filter (Millipore) and vacuum deaerated prior to utilization.

4.4.3. EXPERIMENTAL CONDITIONS

The assay was carried out on a Bioanalytical Systems (BAS) model LC-304 HPLC. Table 4-2. gives a summary of all the technical particulars.

Table 4.2. Technical particulars for HPLC-ED assay of GABA.

Stationary phase	7.5 X 4.6mm Ultrasphere ODS column (C18 reverse phase, particle size 5 μ m)
Detector	Waters M460 electrochemical detector with a glassy carbon electrode set at + 0.7V vs. the Ag/AgCl reference electrode (filled with 3M NaCl) and a sensitivity of 2nA/V
Pump	Beckman (model 110B) Solvent Delivery Module with a single piston
Flow speed	1.2ml/min
Temperature	26°C
Integrator	Spectra-physics (SP-4400) chart speed 0.5cm/min.
Guard column	95mm X 4mm column, packed with HC Pellosil® (High capacity silica gel bonded to 30 - 38 μ m glass bead)

4.4.4. CALIBRATION SOLUTIONS

Stock solutions of GABA and the internal standard, homoserine, were made up from γ -amino-n-butyric acid (Sigma) and DL-homoserine (Sigma) with a mixture of 50% water and 50% methanol. The final concentration for both of the stock solutions was 5 μ g/ml. Aliquots of these solutions were mixed to yield a working stock solution, which was used to calibrate the integrator on a daily basis.

4.4.5. SAMPLE PREPARATION

Following dissection of the hippocampi, approximately 10mg of the tissue of each rat was placed individually into polypropylene tubes and frozen with liquid nitrogen.

On the day of analysis, samples were weighed, thawed, and 2ml of a 0.05N perchloric acid solution (HClO₄) was added to each tube. The tissue in each tube was then ruptured by sonication (2 X 12 seconds, at an amplitude of 14μm).

Samples were centrifuged at 4°C in a Beckman Ultra centrifuge (Model L5-40) for 15min. at 24000Xg. The supernatant fluid was removed and immediately frozen with liquid nitrogen. HPLC analysis was performed the following day.

4.4.6. SAMPLE INJECTION

Each of the frozen tissue extracts was thawed just prior to injection onto the HPLC column. The pH of the sample was adjusted to 5 with the addition of one drop/ml 10M potassium acetate.

An aliquot of 200μl of the tissue extract was removed with a pipette and placed into another tube to which 600μl of the derivatization reagent o-phthalaldehyde (OPA) / B-mercaptoethanol (BME) was added. The derivatization reagent was prepared by dissolving 27mg of OPA in 1ml of methanol, followed by 5μl of BME and 9ml of 0.1M sodium tetraborate (pH 9.3). The working derivatizing solution used for analysis was prepared by diluting 1ml of the stock reagent with 3ml of 0.1M sodium tetraborate 24hrs prior to use. By preparing and leaving the reaction mixture for 24hrs, only a single interfering substance, (which co-eluted with homoserine), could be detected at the sensitivity levels necessary for dialysate analysis. Pre-column derivitization was accomplished by mixing 200μl of a tissue dialysate sample with 600μl of the working OPA/BME reagent for exactly 2min. prior to its injection into the analytical column. Homoserine, in a 100μl aliquot, was added as internal standard. This final sample was shaken well prior to injection of 100μl onto the HPLC column.

Results were expressed as ng/g wet weight of tissue.

4.5. STATISTICAL ANALYSIS

Statistical analysis was done in collaboration with the Statistical Consultation Service of the P.U. for C.H.E.

NMDA-receptor parameters (Bmax and Kd) were analysed using a Student's t-test.

Vmax and Km-values, indicating NOS activity in the hippocampus, as well as plasma corticosterone levels, were analysed using a one-way analysis of variance (ANOVA) (StatSoft, Inc. 2001: Statistica Data Analysis Software System, version 6). If statistical significant differences were observed across the groups, post hoc tests were performed comparing the means of the data as measured at different time intervals using the Tukey test.

Hippocampal GABA-levels were analysed using a one-way analysis of variance (ANOVA). If statistical significant differences were observed across the groups, post hoc tests were performed using the Dunnett's test to compare group means each with basal (control) values.

Data resulting from the various treatment regimes were compared to pooled data from the control group, and pooled data from the 21 days ps group respectively, using one-way analysis of variance (ANOVA). Statistical significance was defined at the 95% ($p < 0.05$) level. If significant differences were noted amongst the groups using the ANOVA test, multiple comparisons were subsequently performed using Dunnett's t-test.

All data are expressed as the mean + SEM with statistical significance defined at the 5% ($p < 0.05$) level.

5. EXPERIMENTAL RESULTS

5.1. VALIDATION OF TDS-MODEL

The TDS-model, used in this study, was first validated under our laboratory conditions to determine the effectiveness in inducing PTSD-like sequelae in Sprague-Dawley rats (see par.4.1.1.).

This model was validated measuring plasma corticosterone levels at certain time intervals after exposure to TDS. This was compared to basal values obtained from control animals not exposed to TDS.

5.1.1. PLASMA CORTICOSTERONE LEVELS

Data obtained from the one-way ANOVA for plasma corticosterone levels showed significant differences across the groups [$F(2,15)=86.95$, $p<0.0001$]. Subsequently, the means of plasma corticosterone levels, as measured at different time intervals, were compared using the Tukey test (Figure 5-1).

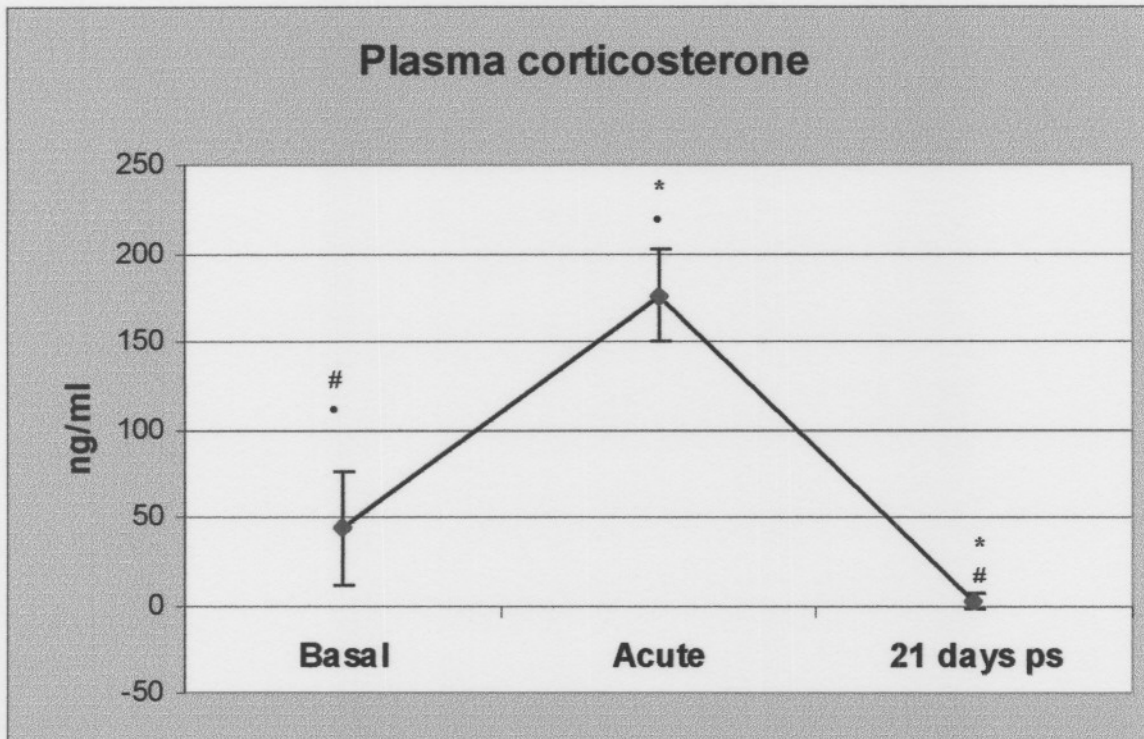

Figure 5-1 The mean \pm SEM ($n=6$) levels of plasma corticosterone as measured at different time intervals in the plasma of experimental animals exposed to the TDS-model.

(* $p < 0.05$ vs basal (Tukey's test).

(# $p < 0.05$ vs acute (Tukey's test).

(• $p < 0.05$ vs 21 days ps (Tukey's test).

According to Figure 5-1, plasma corticosterone levels, as measured \pm 1 hour after the animals were exposed to the initial stressors (Acute = 175.67 ± 26.21 ng/ml), showed a statistically significant increase when compared to values measured in controls (Basal = 43.41 ± 31.63 ng/ml). This is in accordance with data found in literature, where exposure to acute stress results in a significant increase in corticosterone secretion (Axelrod, 1984; Bremner *et al*, 1999b; Heim & Nemeroff, 1999).

Figure 5-1 indicates that the plasma corticosterone levels measured 21 days after exposure to TDS-stress (1.88 ± 4.16 ng/ml), showed a statistically significant decrease when compared to values measured in control animals. This finding is in accordance with results found in the clinical literature where PTSD displays a decrease in the release of glucocorticoids as opposed to an increase seen in other anxiety disorders (Boscarino, 1996; Heim *et al*, 2000; Yehuda *et al*, 1996; Yehuda, 1997).

Data generated 21 days ps is of significance too since the release of corticosteroids, measured after exposure of animals to TDS, were found to mimic the release of cortisol, as observed in human patients suffering from PTSD. It was therefore concluded that this model induces an endogenous stress response, akin to that of PTSD, in Sprague-Dawley animals and could thus be used as a model for PTSD.

5.2. CONTROL VS. EXPERIMENTAL VALUES

In the first part of this study, the activity of NOS, NMDA receptor characteristics (Bmax and Kd), and GABA levels were determined in the hippocampi of control rats (basal value), and compared to rats exposed to TDS. Animals from the experimental group exposed to TDS were sacrificed at different time intervals ranging from directly after exposure to the initial stressors (Acute), after the re-stress session (0 days ps), and 21 days after the re-stress session (21 days ps).

Hippocampal NOS Vmax and Km-values were analysed using one-way ANOVA. If statistical significant differences were observed across the groups, post hoc tests were performed comparing the means of data as measured at different time intervals using the Tukey test.

Hippocampal GABA-levels were analysed using one-way ANOVA. If statistical significant differences were observed across the groups, post hoc tests were performed using the Dunnett's test.

Bmax and Kd values, indicating NMDA receptor binding characteristics, were analysed using the Students t-test.

In all cases data are expressed as the mean \pm SEM with statistical significance defined at the 5% ($p < 0.05$) level.

The results obtained from this study are summarized in table 5.1 and 5.2 at the end of the chapter. The tables include mean + SEM and n, and indicates statistical significant differences.

5.2.1. NOS ACTIVITY

5.2.1.1. NOS Vmax

Data obtained from the one-way ANOVA for Vmax data showed significant differences across the groups [$F(3,43)=12.56$, $p<0.0001$]. Subsequently, the means of Vmax data, measured at different time intervals, were compared using Tukey's test (Figure 5-2).

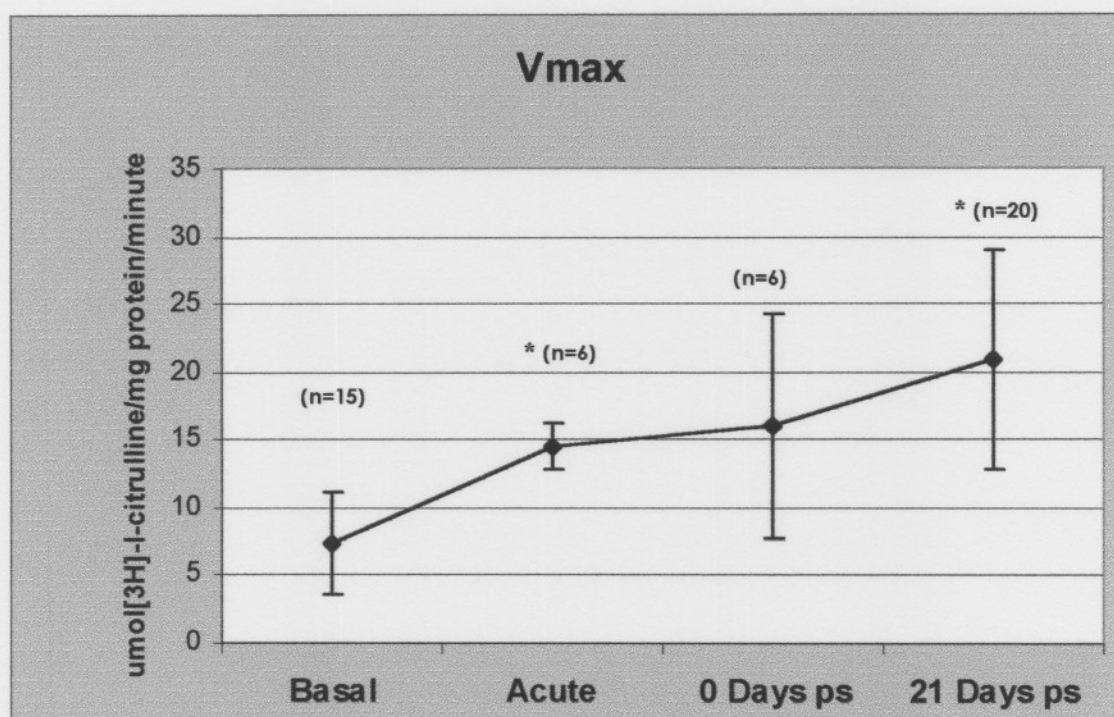

Figure 5-2 The mean \pm SEM values for NOS reaction speed measured in the hippocampi of experimental animals exposed to TDS.

(* $p<0.05$ vs basal (Tukeys' test)).

According to Figure 5-2, the rate of conversion of l-arginine to l-citrulline, under the influence of the NOS-enzymes, was found to be increased in the hippocampi of animals exposed to TDS, when compared to basal values ($7.41 \pm 3.78 \mu\text{mol } [^3\text{H}]\text{-l-citrulline/mg protein/minute}$).

Figure 5-2 indicates that this increase was found to be statistically significant when measured directly after exposure to the initial stressor (Acute) ($14.44 \pm 1.72 \mu\text{mol } [^3\text{H}]\text{-l-citrulline/mg protein/minute}$) and 21 days after the re-stress session (21 days ps) ($20.95 \pm 8.11 \mu\text{mol } [^3\text{H}]\text{-l-citrulline/mg protein/minute}$).

No statistically significant differences were observed when the V_{max} values measured after acute stress, re-stress, and 21 days ps were compared.

5.2.1.2. NOS Km

Data obtained from the one-way ANOVA for Km data (Figure 5-3) showed no significant differences across the groups [$F(3,43)=1.35$, $p=0.7915$]. Subsequently, no post hoc tests were performed on these data.

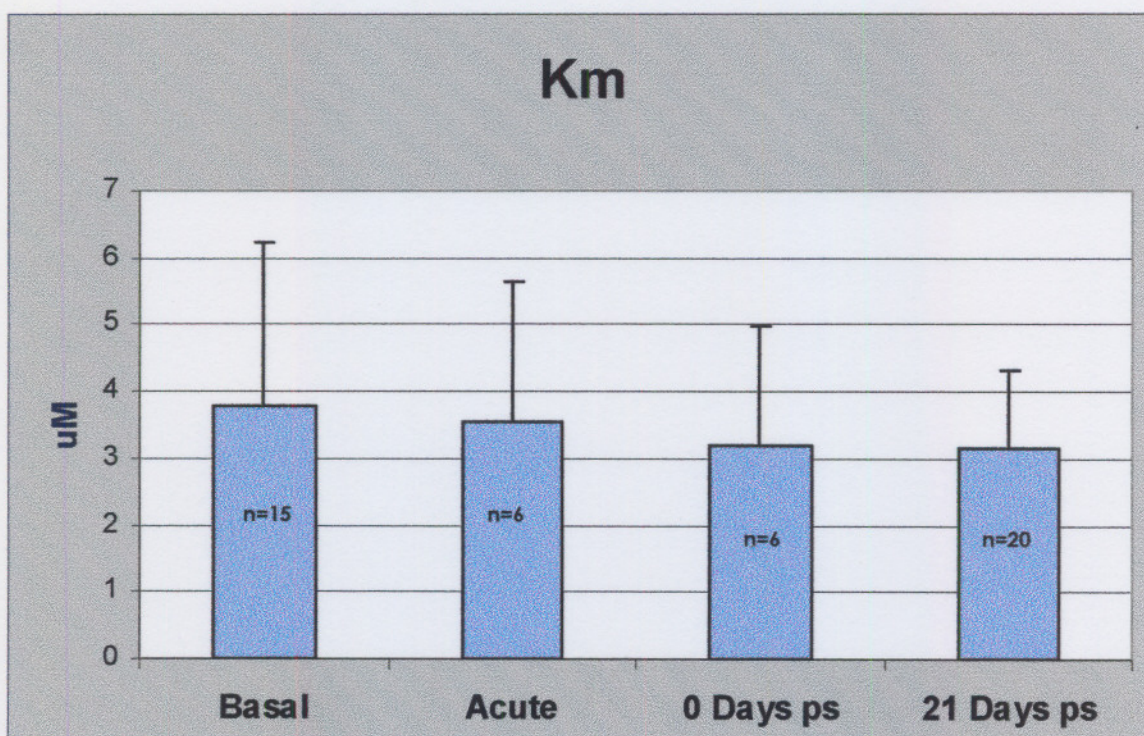

Figure 5-3 The mean \pm SEM Km values for NOS activity measured in the hippocampi of both control animals and animals exposed to TDS.

According to Figure 5-3 the Km-value of NOS, measured at different time intervals after TDS-exposure, showed no significant difference when compared to the Km-values of the group not exposed to TDS-stress. All the Km values measured were in the reported range of 2-20 μ M (Bredt & Schmidt, 1996).

5.2.2. NMDA RECEPTOR CHARACTERISTICS

5.2.2.1. NMDA Bmax

Data obtained from the Students t-test showed a significant difference when comparing basal to 21 days ps data [$t=2.57$, $df=21.4$, $p=0.0178$].

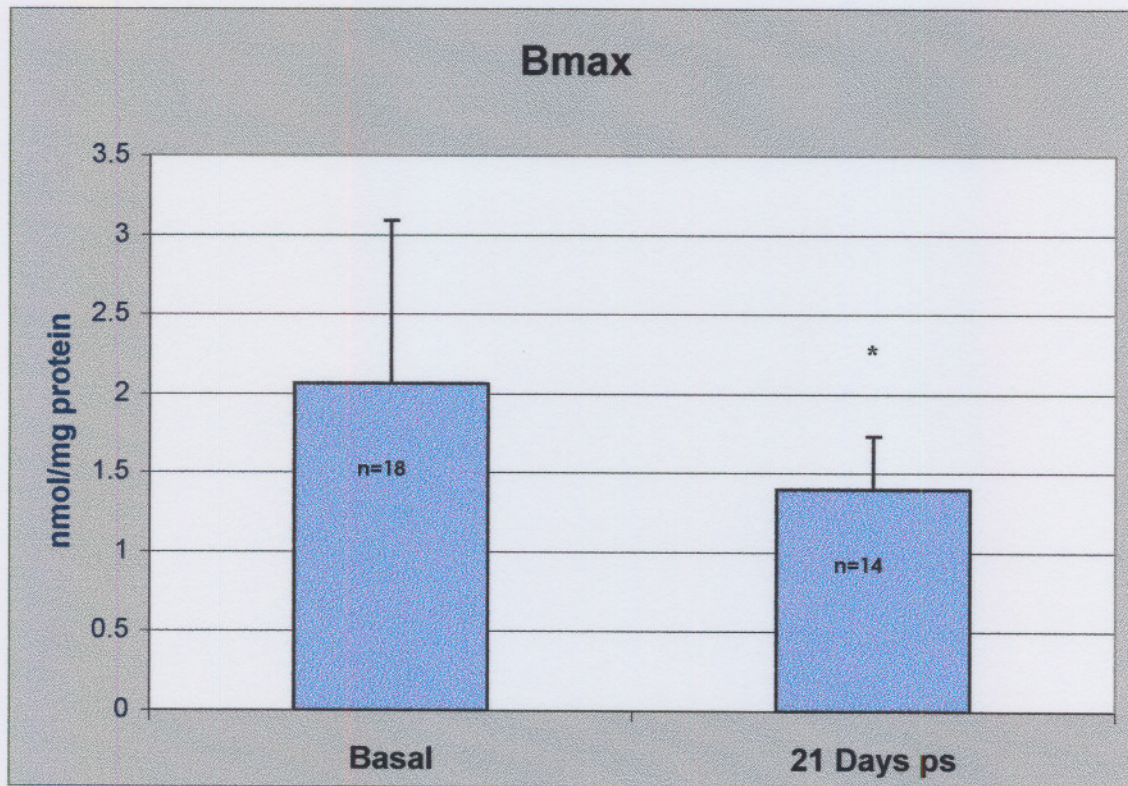

Figure 5-4 The effects of TDS-exposure on NMDA receptor binding density (mean \pm SEM) as measured in the hippocampi of rats.

(*) $p < 0.05$ vs basal (Students *t*-test).

Figure 5-4 indicates that a statistically significant decrease was observed in the NMDA receptor density in the hippocampi of Sprague-Dawley rats exposed to TDS-stress (1.40 ± 0.34 nmol/mg protein), when compared to the density of NMDA receptors in the hippocampi of control animals (2.06 ± 1.03 nmol/mg protein).

5.2.2.2. NMDA Kd

Data obtained from the Students t-test showed no significant difference when comparing basal Kd values to Kd values obtained 21 days ps [$t=0.42$, $df=29.8$, $p=0.6784$].

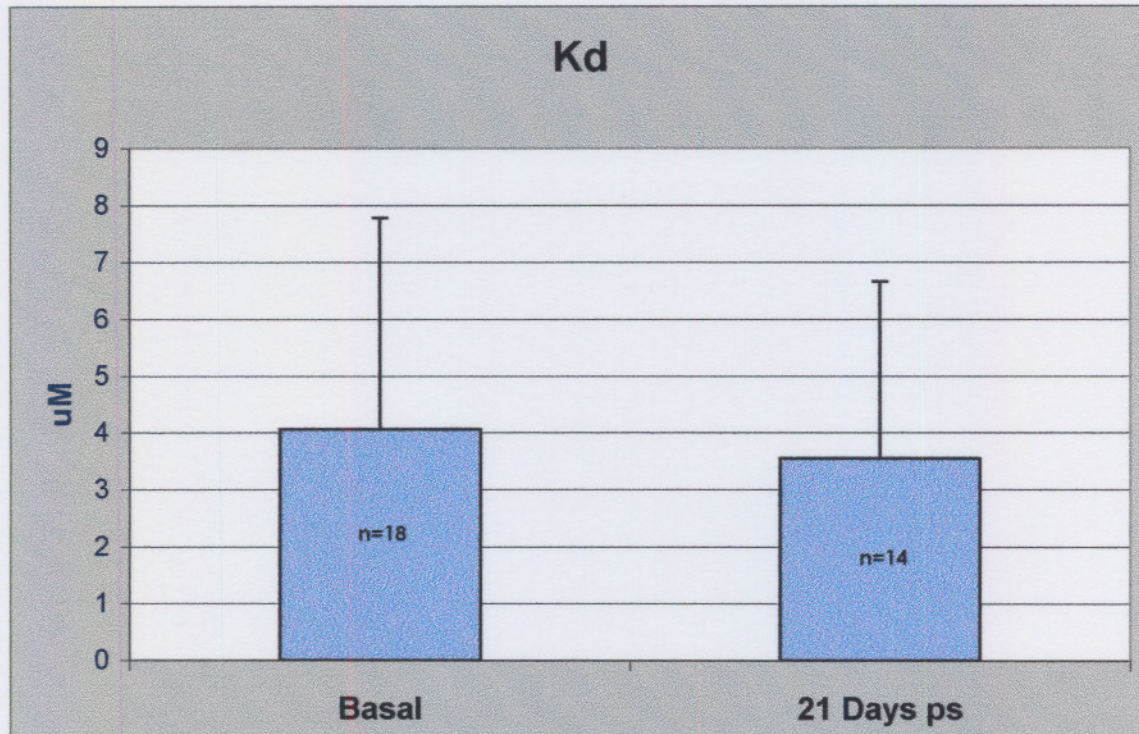

Figure 5-5 The effect of TDS-exposure on Kd values (mean \pm SEM) for [^3H] MK 801 binding in the hippocampi of animals.

As indicated in Figure 5-5, no statistically significant difference was observed in the Kd values of [^3H] MK 801 binding in the hippocampi of animals exposed to TDS-stress ($3.55 \pm 3.11 \mu\text{M}$), when compared to Kd values in the hippocampi of control animals ($4.06 \pm 3.72 \mu\text{M}$).

5.2.3. GABA LEVELS

Data obtained from the one-way ANOVA of GABA levels showed significant differences across the groups [$F(2,18)=39.64$, $p<0.0001$]. Subsequently, the means of this data was compared using the Dunnett's t-test (Figure 5-6).

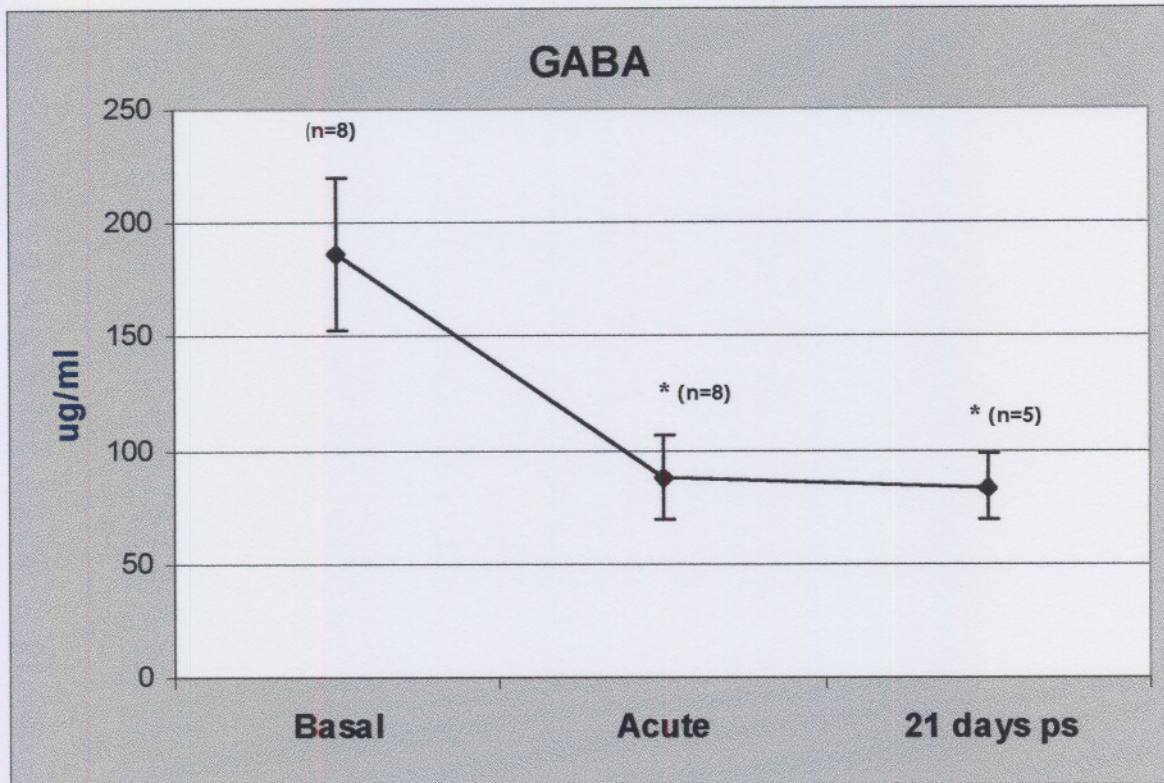

Figure 5-6 The mean \pm SEM of GABA levels as determined in the hippocampi of animals exposed to TDS-stress, as compared to basal values.

(*) $p<0.05$ vs basal (Dunnett's test).

According to Figure 5-6, GABA levels, measured at the different time intervals (acute = $88.03 \pm 18.54 \mu\text{g/ml}$, and 21 days ps = $83.71 \pm 14.14 \mu\text{g/ml}$) were statistically significantly decreased when compared to GABA levels ($185.93 \pm 33.71 \mu\text{g/ml}$) in the hippocampi of control animals (Dunnett's t-test).

5.3. DRUG TREATMENT

In the second part of this study, animals were pre-treated with certain drugs for a period of 21 days. On day 14 of the drug treatment they were exposed to the triple stress session of the TDS-model, and on day 21 (last day of the drug treatment) re-exposed to the forced swimming test. The animals were then left for another 21 days without subjection to any further stressors or injections, where after they were decapitated and the hippocampus removed for analysis.

NOS activity, measured in animals that received drug treatment prior to exposure to TDS-stress, was only assayed on day 21 after re-exposure to the forced swimming test. This time interval was chosen because prior data confirmed statistically significant differences measured at this time interval in the above-mentioned parameters (par 5.2.).

Data resulting from the various treatment regimes were compared to pooled data from the control group, and pooled data from the 21 days ps group respectively (as discussed in par. 5.2.), using one-way ANOVA. Statistical significance was defined at the 5% ($p < 0.05$) level. If significant differences were noted amongst the groups using the ANOVA test, multiple comparisons were subsequently performed using Dunnett's t-test (Miller, 1980). All data are expressed as the mean + SEM with statistical significance defined at the 5% ($p < 0.05$) level.

The results obtained from this study are summarized in table 5.1 and 5.2 at the end of the chapter. The tables include mean + SEM, and n, and indicate statistical significant differences.

5.3.1 FLUOXETINE

Fluoxetine was administered to two separate groups of animals. The one group received 10mg/kg for 21 days, while the other group received 20mg/kg for 21 days. This was done to determine whether the dose of fluoxetine would affect NOS activity and NMDA receptor parameters in the hippocampus.

5.3.1.1. NOS ACTIVITY

5.3.1.1.1. NOS Vmax

Data obtained from the one-way ANOVA of Vmax data showed significant differences across the groups when comparing groups receiving drug treatment to basal values [$F(5,52)=17.04$, $p<0.0001$], and to 21 days ps values [$F(5,57)=14.84$, $p<0.0001$]. Multiple comparisons were subsequently performed using Dunnett's t-test (Figure 5-7)

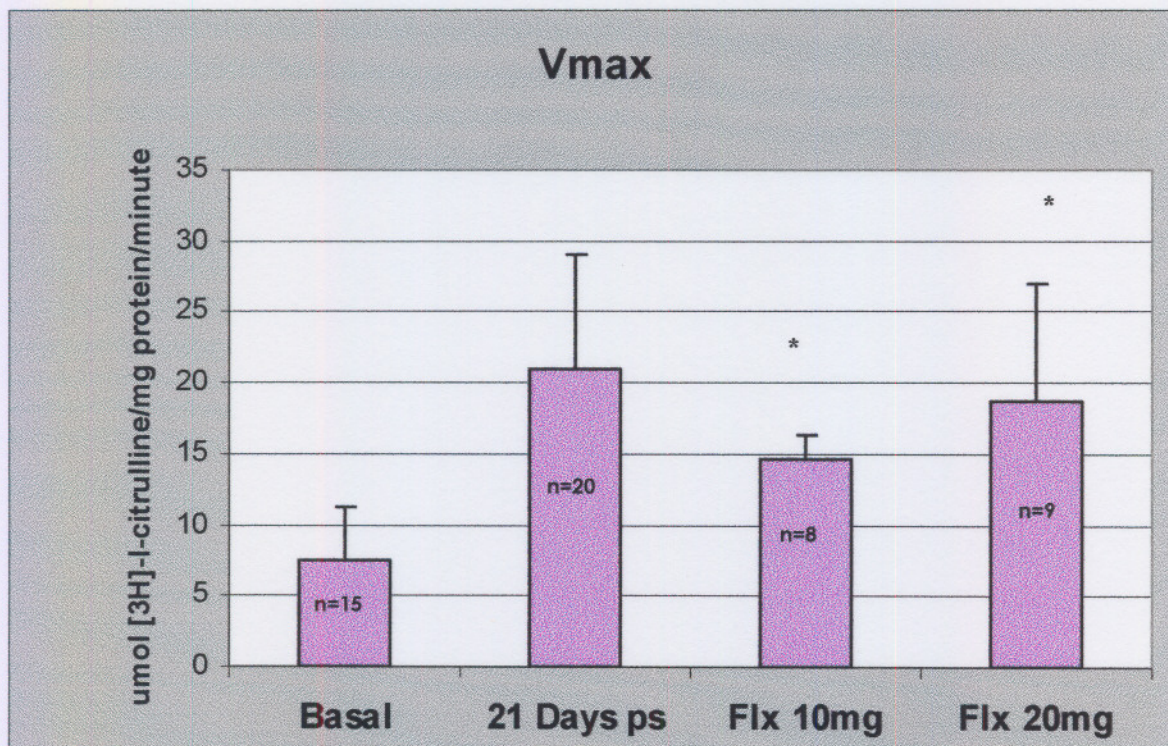

Figure 5-7 The mean \pm SEM of NOS Vmax values in animals pre-treated with fluoxetine prior to exposure to TDS, as compared to both basal Vmax values, and Vmax values of animals exposed to TDS, without drug treatment.

* $p<0.05$ vs basal (Dunnett's t-test).

According to Figure 5-7, the Vmax values of $[^3\text{H}]\text{-l-arginine}$ conversion to $[^3\text{H}]\text{-l-citrulline}$ in the hippocampi of animals, pre-treated with fluoxetine (10mg/kg/day = $14.58 \pm 1.73 \mu\text{mol}$

[³H]-l-citrulline/mg protein/minute, and 20mg/kg/day = $18.64 \pm 8.40\mu\text{mol}$ [³H]-l-citrulline/mg protein/minute), and exposed to TDS, were shown to be statistically significantly increased above V_{max} values of NOS in the hippocampi of control animals ($7.41 \pm 3.78\mu\text{mol}$ [³H]-l-citrulline/mg protein/minute). No difference was observed when V_{max} values of fluoxetine pre-treatment were compared to V_{max} values of NOS in the hippocampi of animals exposed to TDS, without drug treatment ($20.95 \pm 8.11\mu\text{mol}$ [³H]-l-citrulline/mg protein/minute).

The V_{max} values of NOS in the hippocampus of animals pre-treated with fluoxetine 10mg/kg/day, as well as 20mg/kg/day, were thus statistically significantly elevated above basal values, but in the same range as the V_{max} values of animals exposed to TDS-stress, receiving no drug treatment.

5.3.1.1.2. NOS Km

Data obtained from the one-way ANOVA of Km data showed significant differences across the groups when comparing groups receiving drug treatment to basal values [$F(5,46)=12.41$, $p<0.0001$], and to 21 days ps values [$F(5,51)=19.62$, $p<0.0001$]. Multiple comparisons were subsequently performed using Dunnett's t-test (Figure 5-8).

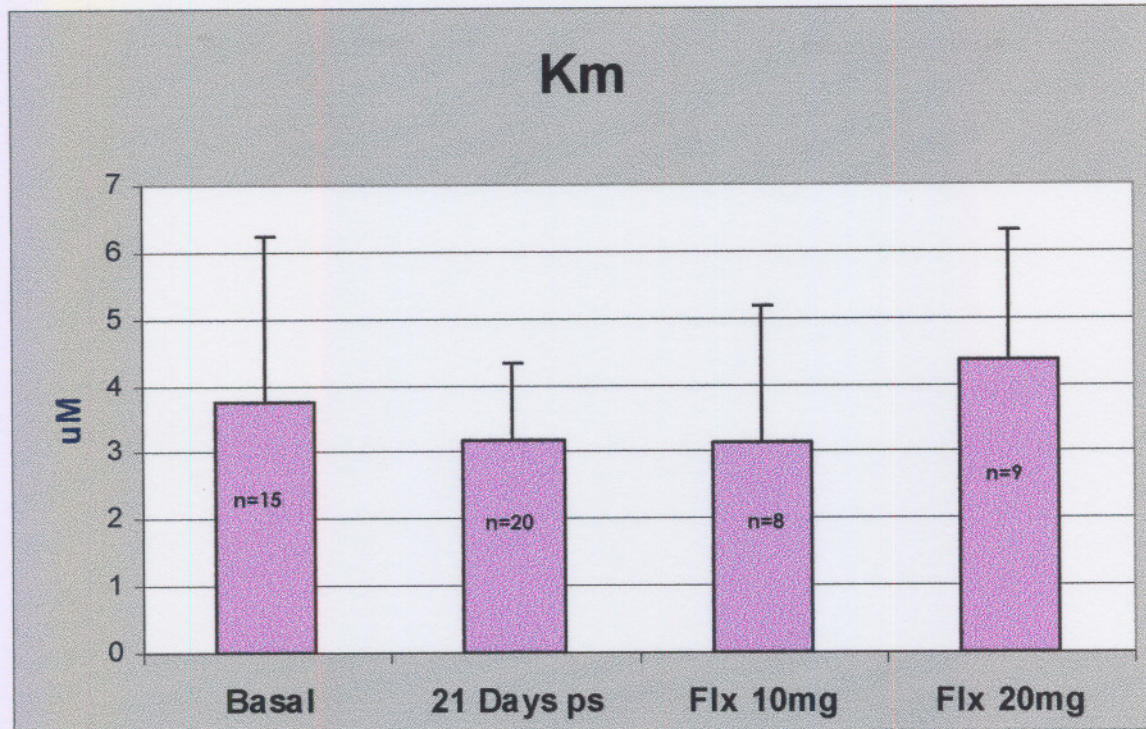

Figure 5-8 The mean \pm SEM of Km values in the hippocampi of animals pre-treated with fluoxetine, compared to Km values in control animals, and Km values measured in animals exposed to TDS-stress.

According to Figure 5-8, no statistically significant difference was found between the Km values of NOS in the hippocampi of animals pre-treated with fluoxetine (both 10mg/kg/day = $3.13 \pm 2.05\mu\text{M}$ and 20mg/kg/day = $4.36 \pm 1.93\mu\text{M}$), when compared to basal Km values ($3.77 \pm 2.46\mu\text{M}$) and 21 days ps Km values ($3.16 \pm 1.16\mu\text{M}$).

All of the Km values were in the reported range of 2-20 μM (Bredt & Schmidt, 1996).

5.3.1.2. NMDA RECEPTOR CHARACTERISTICS

5.3.1.2.1. NMDA Bmax

Data obtained from the one-way ANOVA of Bmax data showed significant differences across the groups when comparing groups receiving drug treatment to basal values [$F(5,60)=7.86$, $p<0.0001$], and to 21 days ps values [$F(5,56)=6.55$, $p<0.0001$]. Multiple comparisons were subsequently performed using Dunnett's t-test (Figure 5-9).

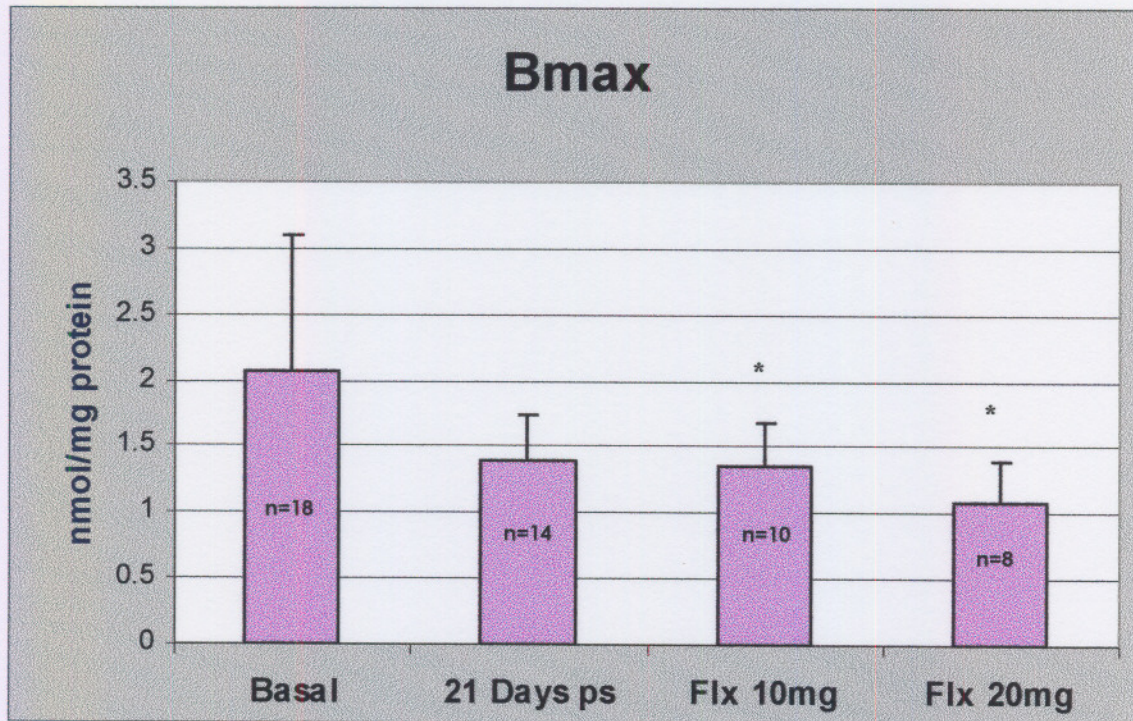

Figure 5-9 The mean \pm SEM of Bmax values obtained for [^3H]-MK801 in the hippocampi of animals pre-treated with fluoxetine, compared to Bmax values measured in the hippocampi of control animals, and Bmax values measured in animals exposed to TDS-stress.

* $p<0.05$ vs basal (Dunnett's t-test).

According to figure 5-9, the Bmax values of [^3H] MK 801 binding to the hippocampal membranes of animals pre-treated with fluoxetine (10mg/kg/day = 1.36 ± 0.32 nmol/mg protein, and 20mg/kg/day = 1.08 ± 0.31 nmol/mg protein), were statistically significantly decreased when compared to basal values (2.06 ± 1.03 nmol/mg protein).

No statistically significant difference was observed when this data was compared to Bmax values of [^3H] MK 801 binding to the hippocampal membranes of animals 21 days

ps (1.4 ± 0.34 nmol/mg protein).

5.3.1.2.2. NMDA Kd

Data obtained from the one-way ANOVA of Kd data showed no significant differences when comparing the groups receiving drug treatment to basal [$F(5,60)=1.15$, $p=0.3430$] and 21 days ps groups [$F(5,56)=0.94$, $p=0.4605$] (Figure 5-10).

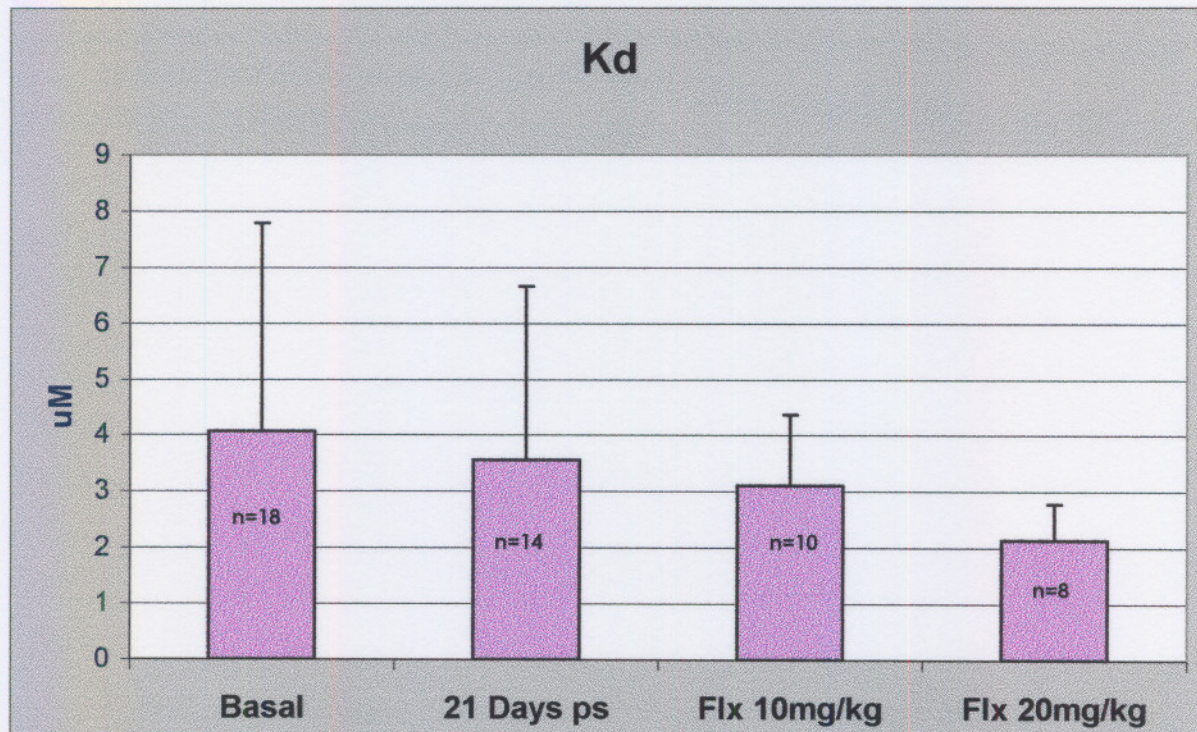

Figure 5-10 Mean \pm SEM of Kd values measured by [3 H] MK 801 binding in the hippocampi of animals pre-treated with fluoxetine prior to TDS-exposure, as compared to basal value Kd and Kd measured on 21 days ps.

According to Figure 5-10, no statistically significant difference was observed when the Kd values of [3 H] MK 801 binding in the hippocampi of animals pre-treated with fluoxetine (10mg/kg/day = 3.11 ± 1.26 μ M and 20mg/kg/day = 2.14 ± 0.64 μ M) were compared to either basal Kd values (4.06 ± 3.72 μ M) or Kd values of 21 days ps (3.55 ± 3.11 μ M).

5.3.2. AMINO GUANIDINE

5.3.2.1. NOS ACTIVITY

5.3.2.1.1. NOS Vmax

Data obtained from the one-way ANOVA of Vmax data showed significant differences across the groups when comparing groups receiving drug treatment to basal values [$F(5,52)=17.04$, $p<0.0001$], and to 21 days ps values [$F(5,57)=14.84$, $p<0.0001$]. Multiple comparisons were subsequently performed using Dunnett's t-test (Figure 5-11).

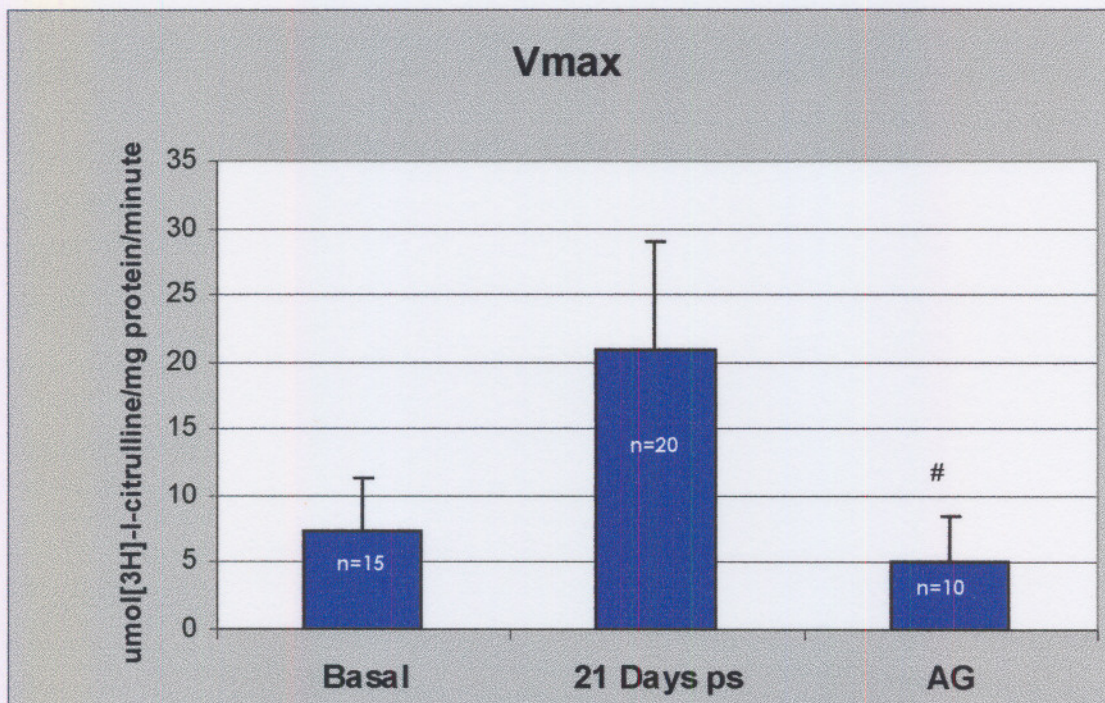

Figure 5-11 Mean \pm SEM of Vmax values indicating NOS activity in the hippocampi of animals pre-treated with aminoguanidine, prior to TDS-exposure, as compared to basal values and values from 21 days ps.

$p<0.05$ vs 21 days ps (Dunnett's t-test).

According to Figure 5-11, the maximal rate of conversion of $[^3\text{H}]\text{-l-arginine}$ to $[^3\text{H}]\text{-l-citrulline}$, in the hippocampi of animals pre-treated with aminoguanidine ($5.08 \pm 3.48 \mu\text{mol } [^3\text{H}]\text{-l-citrulline/mg protein/minute}$), was not found to be statistically significantly different from basal Vmax values in the hippocampi of control animals ($7.41 \pm 3.78 \mu\text{mol } [^3\text{H}]\text{-l-citrulline/mg protein/minute}$).

These values were however statistically significantly decreased when compared to

increased V_{max} values evident in the hippocampi of animals in the 21 days ps group ($20.95 \pm 8.11 \mu\text{mol } [^3\text{H}]\text{-l-citrulline/mg protein/minute}$).

The results in Figure 5-11 indicate that aminoguanidine inhibits the increase in NOS activity observed in the hippocampi of animals exposed to TDS.

5.3.2.1.2. NOS K_m

Data obtained from the one-way ANOVA of K_m data showed significant differences across the groups when comparing groups receiving drug treatment to basal values [$F(5,46)=1.41$, $p<0.0001$], and to 21 days ps values [$F(5,51)=19.62$, $p<0.0001$]. Multiple comparisons were subsequently performed using Dunnett's t-test (Figure 5-12).

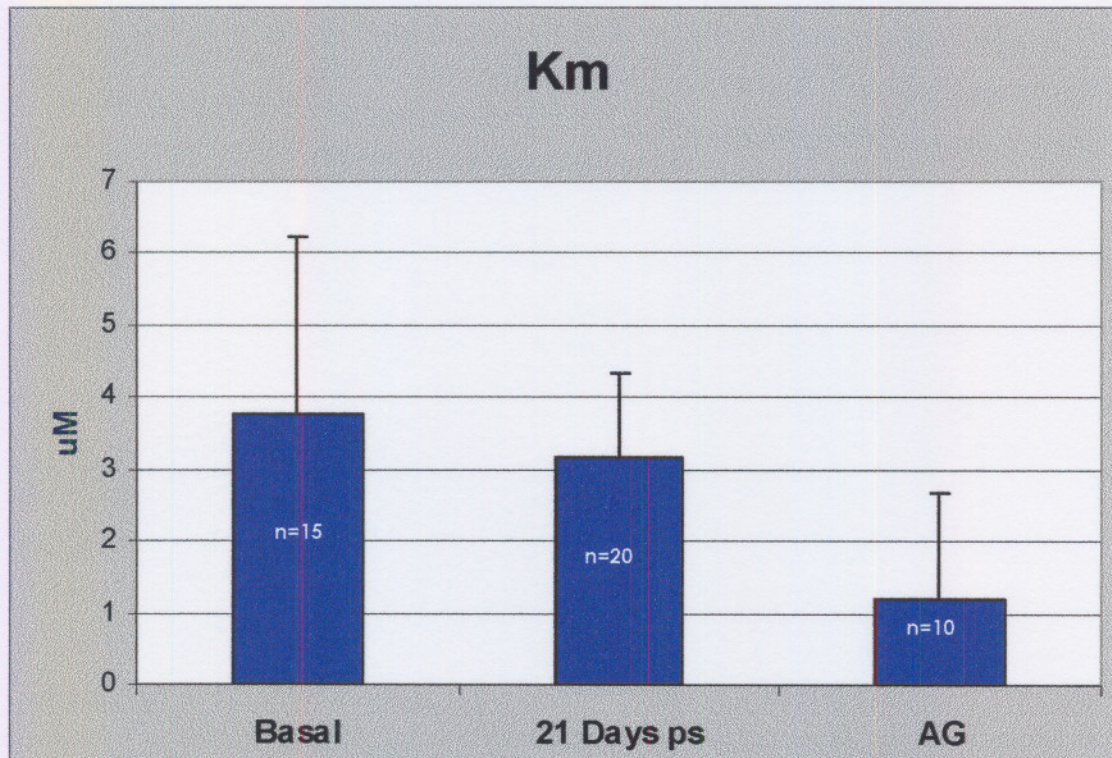

Figure 5-12 The mean \pm SEM of K_m values as determined for NOS in the hippocampi of animals pre-treated with aminoguanidine prior to TDS-exposure, compared to basal value K_m and K_m of 21 days ps.

According to Figure 5-12, there was no statistically significant difference was observed when the K_m value of NOS in animals pre-treated with aminoguanidine ($1.20 \pm 1.47 \mu\text{M}$) was compared to basal values ($3.77 \pm 2.46 \mu\text{M}$).

Figure 5-12 also indicate that no statistically significant change was observed when K_m values for NOS in the hippocampi of animals pre-treated with aminoguanidine, was compared to the K_m values for NOS in the 21 days ps group ($3.16 \pm 1.16 \mu\text{M}$).

5.3.2.2. AMINO GUANIDINE: NMDA RECEPTOR CHARACTERISTICS

5.3.2.2.1. NMDA B_{max}

Data obtained from the one-way ANOVA of B_{max} data showed significant differences across the groups when comparing groups receiving drug treatment to basal values [$F(5,60)=7.86$, $p<0.0001$], and to 21 days ps values [$F(5,56)=6.55$, $p<0.0001$]. Multiple comparisons were subsequently performed using Dunnett's t-test (Figure 5-13).

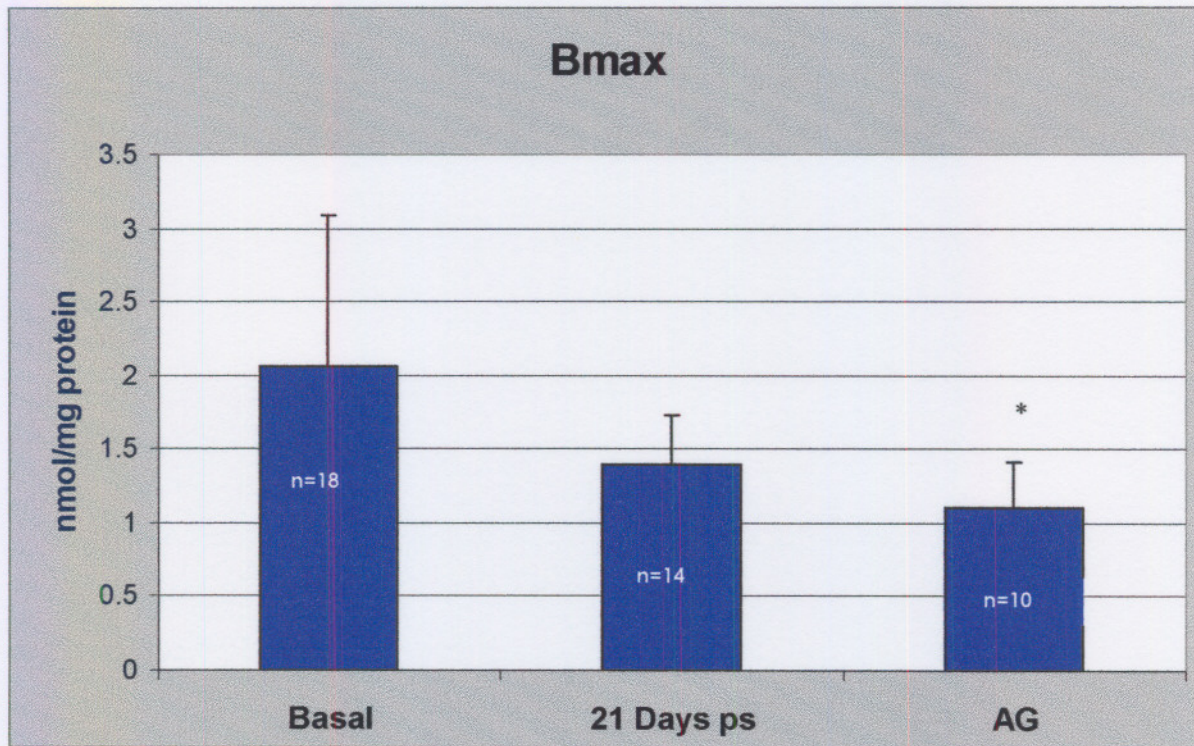

Figure 5-13 The mean \pm SEM of B_{max} values obtained from [^3H] MK 801 binding in the hippocampi of animals pre-treated with aminoguanidine, as compared to basal and 21 days ps values.

* $p<0.05$ vs basal (Dunnett's t-test).

According to Figure 5-13, B_{max} values for [^3H] MK 801 binding in the hippocampus of animals pre-treated with aminoguanidine (1.11 ± 0.32 nmol/mg protein), were statistically significantly decreased when compared to the B_{max} values in the hippocampi of control animals (2.06 ± 1.03 nmol/mg protein).

Figure 5-13 indicates that no statistically significant difference was observed when Bmax values for [³H] MK 801 binding in the hippocampi of animals pre-treated with aminoguanidine, were compared to Bmax values of the 21 days ps group ($1.4 \pm 0.34 \text{ nmol/mg protein}$).

5.3.2.2.2. NMDA Kd

Data obtained from the one-way ANOVA of Kd data showed no significant differences when comparing the groups receiving drug treatment to basal [$F(5,60)=1.15, p=0.3430$] and 21 days ps groups [$F(5,56)=0.94, p=0.4605$] (Figure 5-14).

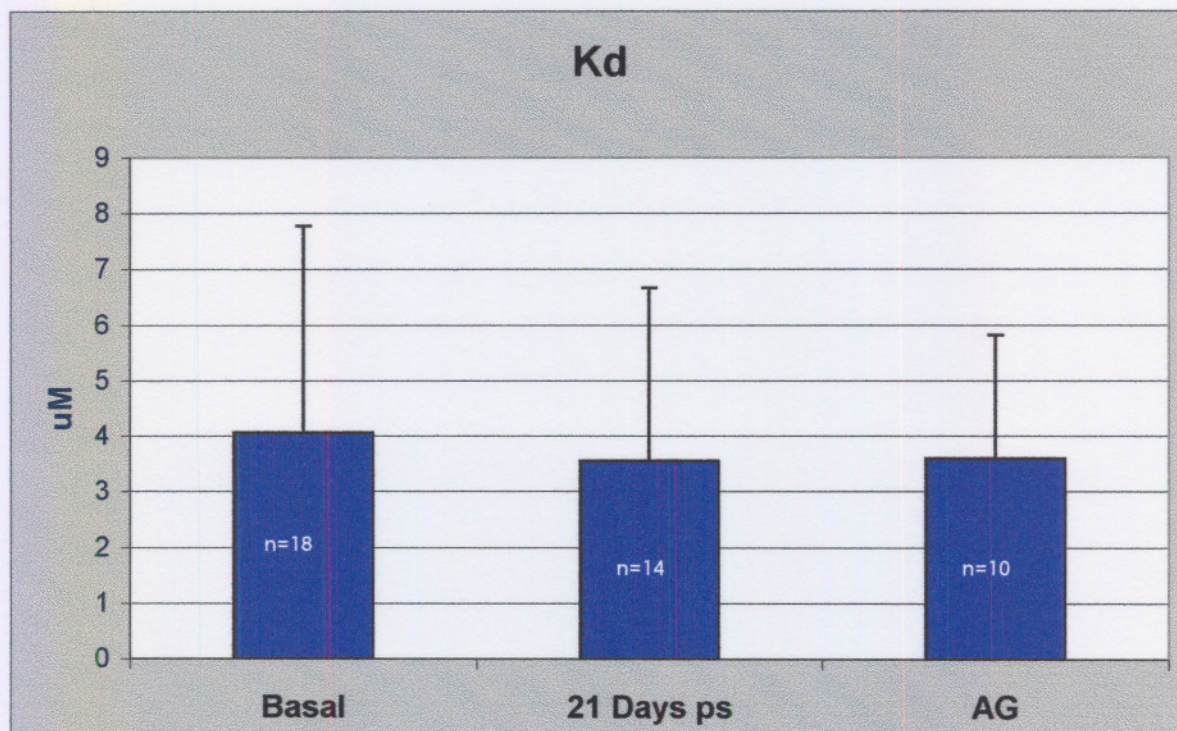

Figure 5-14 Mean \pm SEM values of Kd obtained from [³H] MK 801 binding in the hippocampi of animals pre-treated with aminoguanidine, basal and 21 days ps.

According to Figure 5-14, no statistical significant changes were observed when the Kd value of [³H] MK 801 binding in the hippocampi of animals pre-treated with aminoguanidine ($3.59 \pm 2.22 \mu\text{M}$) was compared to either the control animals ($4.06 \pm 3.72 \mu\text{M}$), or the animals exposed to TDS ($3.55 \pm 3.12 \mu\text{M}$).

5.3.3. 7-NITROINDAZOLE

5.3.3.1. NOS ACTIVITY

5.3.3.1.1. NOS Vmax

Data obtained from the one-way ANOVA of Vmax data showed significant differences across the groups when comparing groups receiving drug treatment to basal values [$F(5,52)=17.04$, $p<0.0001$], and to 21 days ps values [$F(5,57)=14.84$, $p<0.0001$]. Multiple comparisons were subsequently performed using Dunnett's t-test (Figure 5-15).

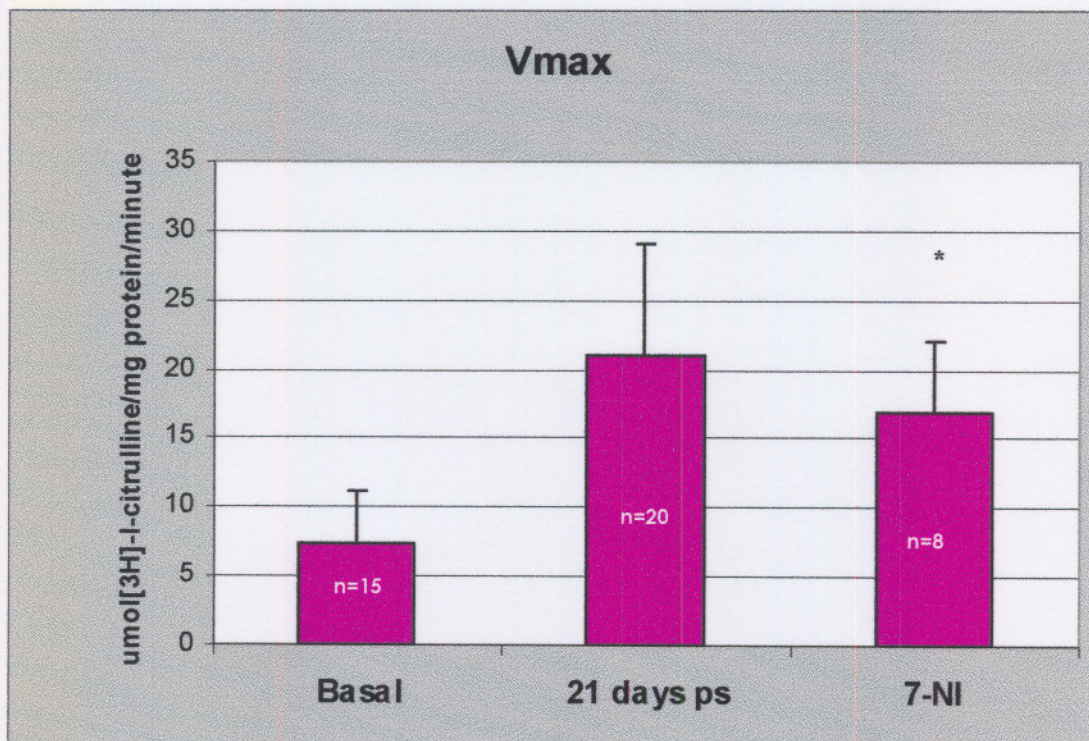

Figure 5-15 Mean \pm SEM levels of [^3H]-l-citrulline formation, measured in the hippocampi of animals after receiving 7-nitroindazole pre-treatment, compared to basal and 21 days ps data.

* $p<0.05$ vs basal (Dunnett's t-test).

According to Figure 5-15, the rate of conversion of [^3H]-l-arginine to [^3H]-l-citrulline, as measured in the hippocampi of animals pre-treated with 7-nitroindazole ($16.83 \pm 5.24 \mu\text{mol}$ [^3H]-l-citrulline/mg protein/minute), were statistically significantly increased above basal values when compared to the control set of data ($7.41 \pm 3.78 \mu\text{mol}$ [^3H]-l-citrulline/mg protein/minute).

Figure 5-15 indicates that no difference was observed when the Vmax values in animals

pre-treated with 7-nitroindazole, was compared to the observations 21 days ps ($20.95 \pm 8.11 \mu\text{mol } [^3\text{H}]\text{-l-citrulline/mg protein/minute}$).

5.3.3.1.2. NOS Km

Data obtained from the one-way ANOVA of Km data showed significant differences across the groups when comparing groups receiving drug treatment to basal values [$F(5,46)=1.41$, $p<0.0001$], and to 21 days ps values [$F(5,51)=19.62$, $p<0.0001$]. Multiple comparisons were subsequently performed using Dunnett's t-test (Figure 5-16).

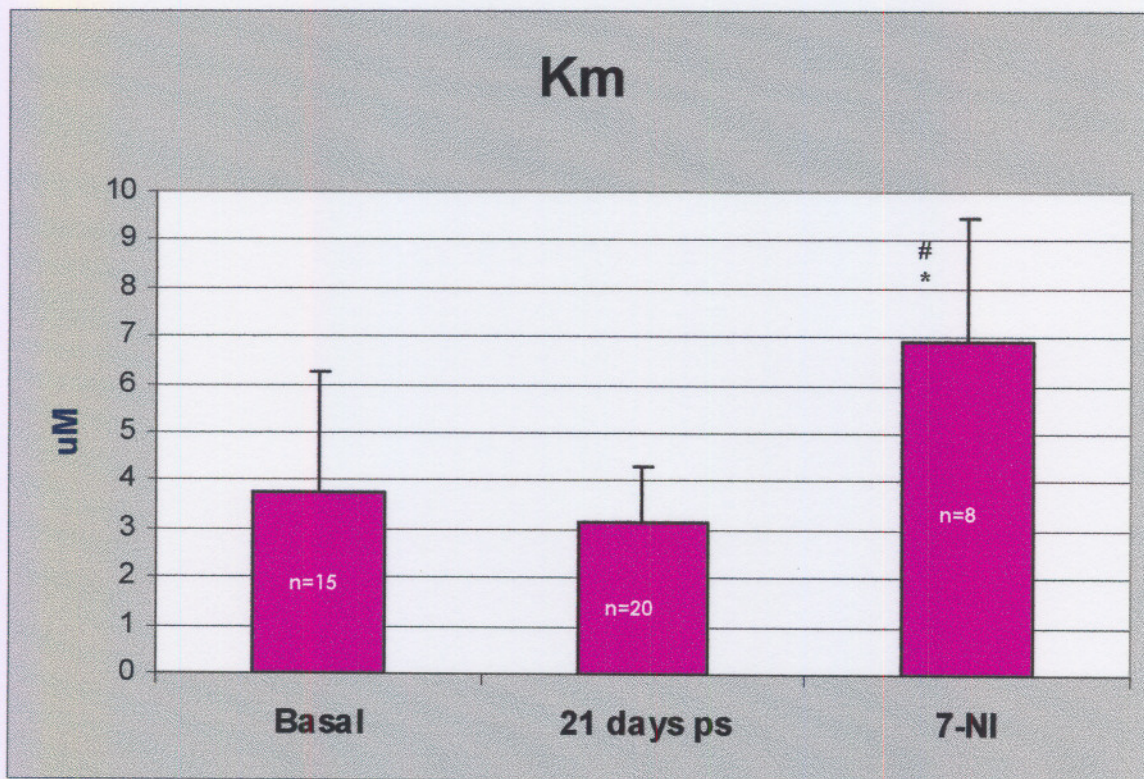

Figure 5-16 Mean \pm SEM of Km values for NOS in the hippocampi of animals pre-treated with 7-nitroindazole, as compared to basal and 21 days ps Km values.

$p<0.05$ vs 21 days ps value (Dunnett's t-test).

* $p<0.05$ vs basal value (Dunnett's t-test).

According to Figure 5-16, Km values of NOS in the hippocampi of animals pre-treated with 7-nitroindazole ($6.88 \pm 2.59 \mu\text{M}$) were statistically significantly increased above the Km levels of 21 days ps ($3.16 \pm 1.16 \mu\text{M}$, and the control group ($3.77 \pm 2.46 \mu\text{M}$).

The Km values of NOS in the hippocampi of animals pre-treated with 7-nitroindazole

were in the reported range for this enzyme (Bredt & Schmidt, 1996).

5.3.3.2. 7-NITROINDAZOLE NMDA RECEPTOR CHARACTERISTICS

5.3.3.2.1. NMDA Bmax

Data obtained from the one-way ANOVA of Bmax data showed significant differences across the groups when comparing groups receiving drug treatment to basal values [$F(5,60)=7.86$, $p<0.0001$], and to 21 days ps values [$F(5,56)=6.55$, $p<0.0001$]. Multiple comparisons were subsequently performed using Dunnett's t-test (Figure 5-17).

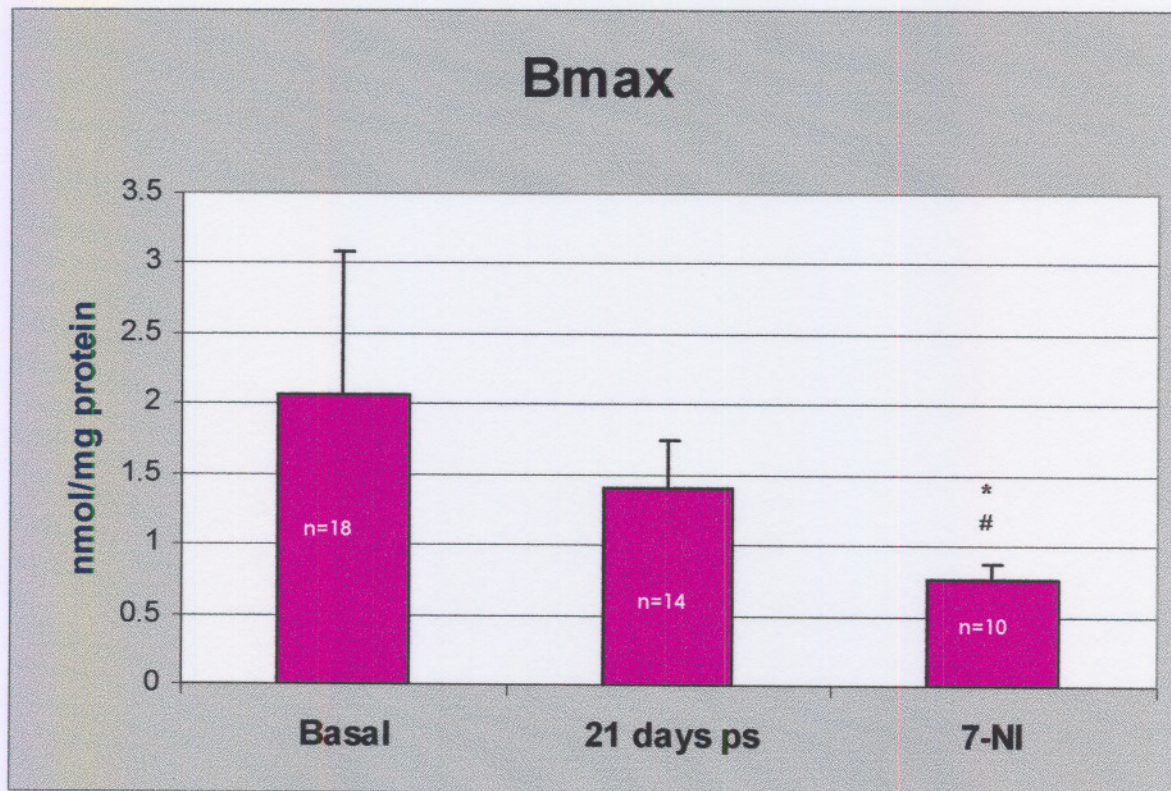

Figure 5-17 Mean \pm SEM for NMDA of Bmax in the hippocampi of animals pre-treated with 7-nitroindazole, as compared to basal Bmax and 21 days ps Bmax values.

* $p<0.05$ vs basal (Dunnett's t-test).

$p<0.05$ vs 21 days ps (Dunnett's t-test).

According to Figure 5-17, the NMDA receptor density in the hippocampus of animals pre-treated with 7-nitroindazole (0.75 ± 0.12 nmol/mg protein), was statistically significantly decreased when compared to the NMDA receptor density in the hippocampi of control animals (2.06 ± 1.03 nmol/mg protein).

Pre-treatment 7-nitroindazole was also found to have decreased NMDA receptor density in the hippocampi of animals pre-treated with 7-nitroindazole when compared to NMDA receptor density in the hippocampi of animals 21 days ps ($1.40 \pm 0.34 \text{ nmol/mg protein}$).

5.3.3.2.2. NMDA Kd

Data obtained from the one-way ANOVA of Kd data showed no significant differences when comparing the groups receiving drug treatment to basal [$F(5,60)=1.15, p=0.3430$] and 21 days ps groups [$F(5,56)=0.94, p=0.4605$] (Figure 5-18).

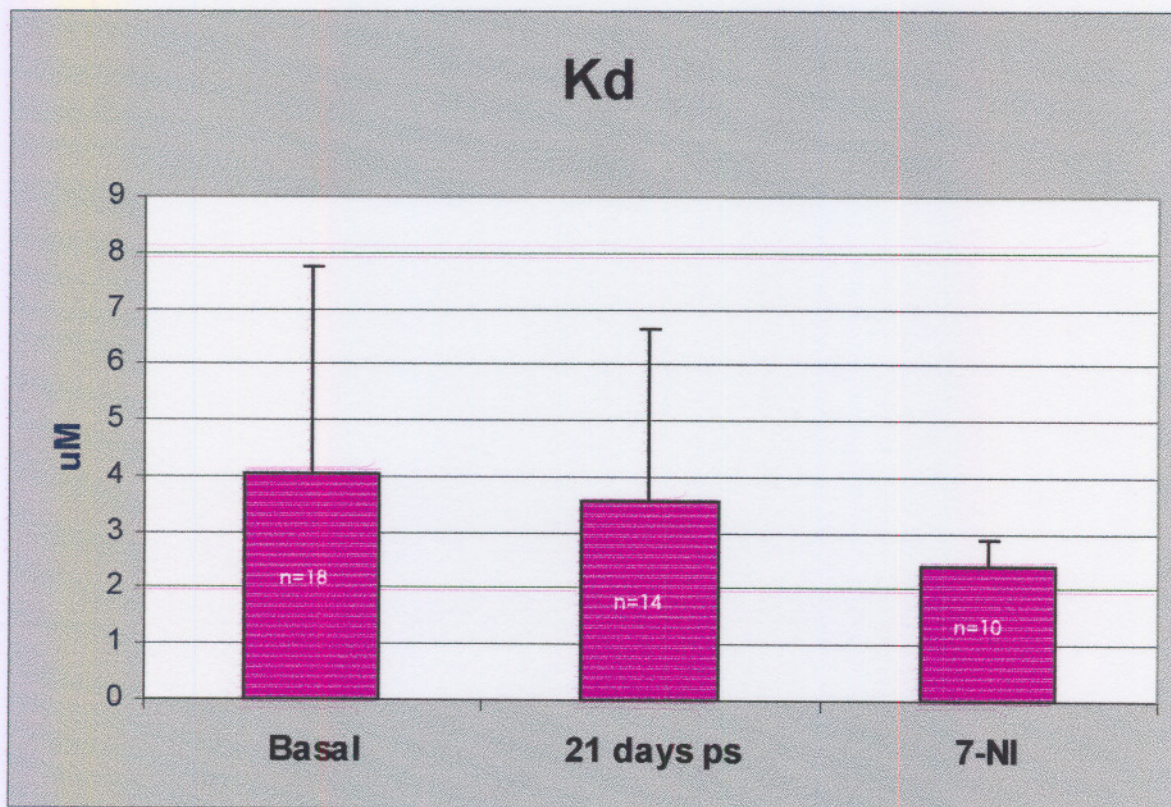

Figure 5-18 Mean \pm SEM of Kd values for [^3H]-MK 801 binding in the hippocampi of animals pre-treated with 7-nitroindazole and exposed to TDS-stress, compared to basal and 21 days ps data.

Figure 5-14 indicates that comparing the Kd values of [^3H] MK 801 binding in the hippocampus of animals pre-treated with 7-nitroindazole ($2.42 \pm 0.48 \mu\text{M}$) to the Kd values of both the control animals ($4.06 \pm 3.72 \mu\text{M}$) as well as the group 21 days ps ($3.55 \pm 3.11 \mu\text{M}$), showed no statistically significant differences.

5.3.4. KETOCONAZOLE

Ketoconazole is an inhibitor of glucocorticoid synthesis. To determine whether the effect of TDS-stress on NOS and NMDA receptor parameters are related to stress-evoked activation of the HPA-axis, ketoconazole was administered to animals prior to TDS-exposure.

5.3.4.1. NOS ACTIVITY

5.3.4.1.1. NOS Vmax

Data obtained from the one-way ANOVA of Vmax data showed significant differences across the groups when compared to basal values [$F(5,52)=17.04$, $p<0.0001$], and to 21 days ps values [$F(5,57)=14.84$, $p<0.0001$]. Multiple comparisons were subsequently performed using Dunnett's t-test (Figure 5-19).

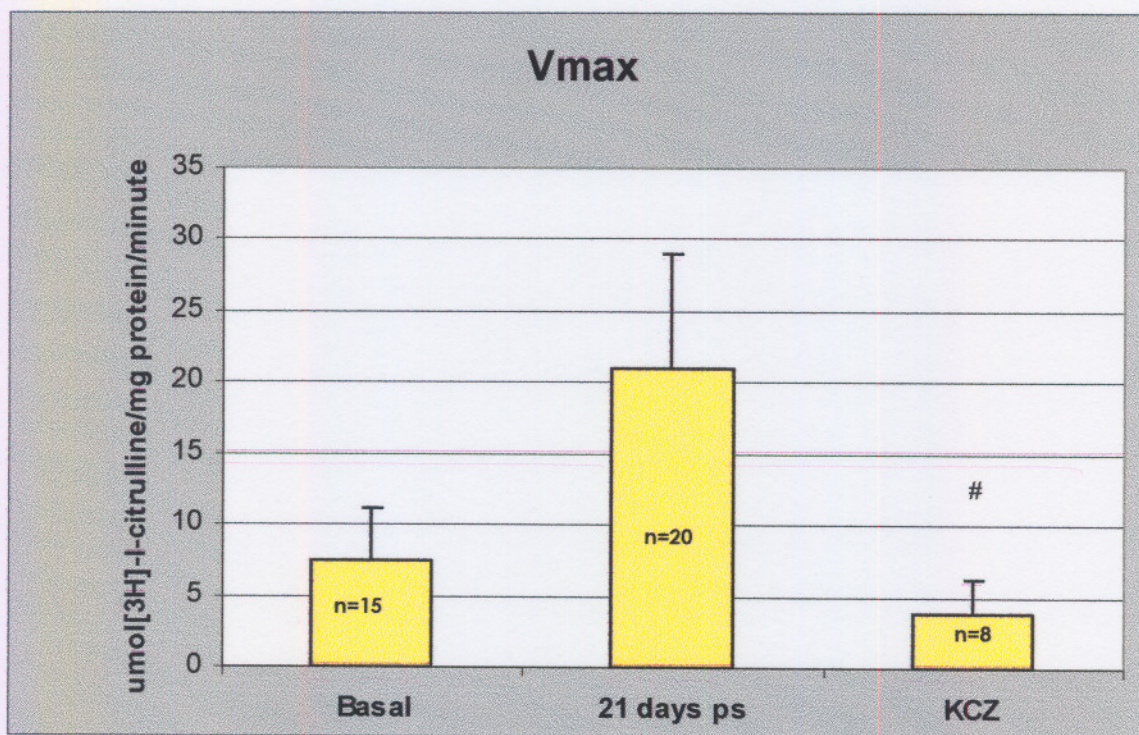

Figure 5-19 The mean \pm SEM Vmax values of NOS in the hippocampi of animals pre-treated with ketoconazole, as compared to basal and 21 days ps values.

$p<0.05$ vs 21 days ps (Dunnett's t-test).

According to Figure 5-19, no statistically significant difference was observed in the rate of conversion of [^3H]-l-arginine to [^3H]-l-citrulline when the Vmax values of NOS in the hippocampi of animals pre-treated with ketoconazole ($3.81 \pm 2.40 \mu\text{mol}$ [^3H]-l-

citrulline/mg protein/minute) were compared to the V_{max} values of NOS in the hippocampi of control animals ($7.41 \pm 3.78 \mu\text{mol } [^3\text{H}]\text{-l-citrulline/mg protein/minute}$).

Figure 5-19 indicates a statistically significant decrease when the rate of conversion in the hippocampi of animals pre-treated with ketoconazole was compared to the V_{max} values of NOS in the hippocampi of the 21 days ps group ($20.95 \pm 8.11 \mu\text{mol } [^3\text{H}]\text{-l-citrulline/mg protein/minute}$).

5.3.4.1.2. NOS K_m

Data obtained from the one-way ANOVA for K_m data showed significant differences across the groups when comparing groups receiving drug treatment to basal values [$F(5,46)=12.41$, $p<0.0001$], and to 21 days ps values [$F(5,51)=19.62$, $p<0.0001$]. Multiple comparisons were subsequently performed using Dunnett's t-test (Figure 5-20).

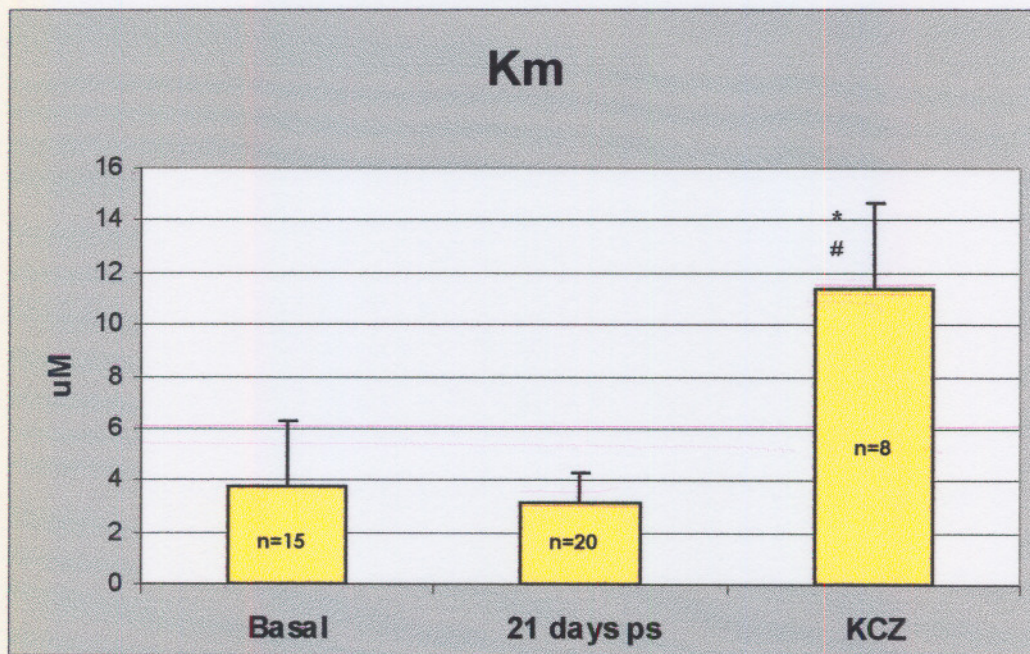

Figure 5-20 Mean \pm SEM of K_m values for NOS in the hippocampi of animals pre-treated with ketoconazole, as compared to basal values and values obtained 21 days ps.

* $p<0.05$ vs basal (Dunnett's t-test).

$p<0.05$ vs 21 days ps (Dunnett's t-test).

According to Figure 5-10, the K_m values for NOS in the hippocampi of animals pre-treated with ketoconazole ($11.32 \pm 3.31 \mu\text{M}$) were statistically significantly increased above the K_m values for NOS in the hippocampi of both control animals ($3.77 \pm 2.46 \mu\text{M}$),

and animals 21 days ps ($3.16 \pm 1.16\mu\text{M}$).

The K_m values for NOS in the hippocampi of animals pre-treated with ketoconazole were in the reported K_m -range for this enzyme (Bredt & Schmidt, 1996).

5.3.4.2. NMDA RECEPTOR CHARACTERISTICS

5.3.4.1.1. NMDA B_{max}

Data obtained from the one-way ANOVA of B_{max} data showed significant differences across the groups when comparing groups receiving drug treatment to basal values [$F(5,60)=7.86$, $p<0.0001$], and to 21 days ps values [$F(5,56)=6.55$, $p<0.0001$]. Multiple comparisons were subsequently performed using Dunnett's t-test (Figure 5-21).

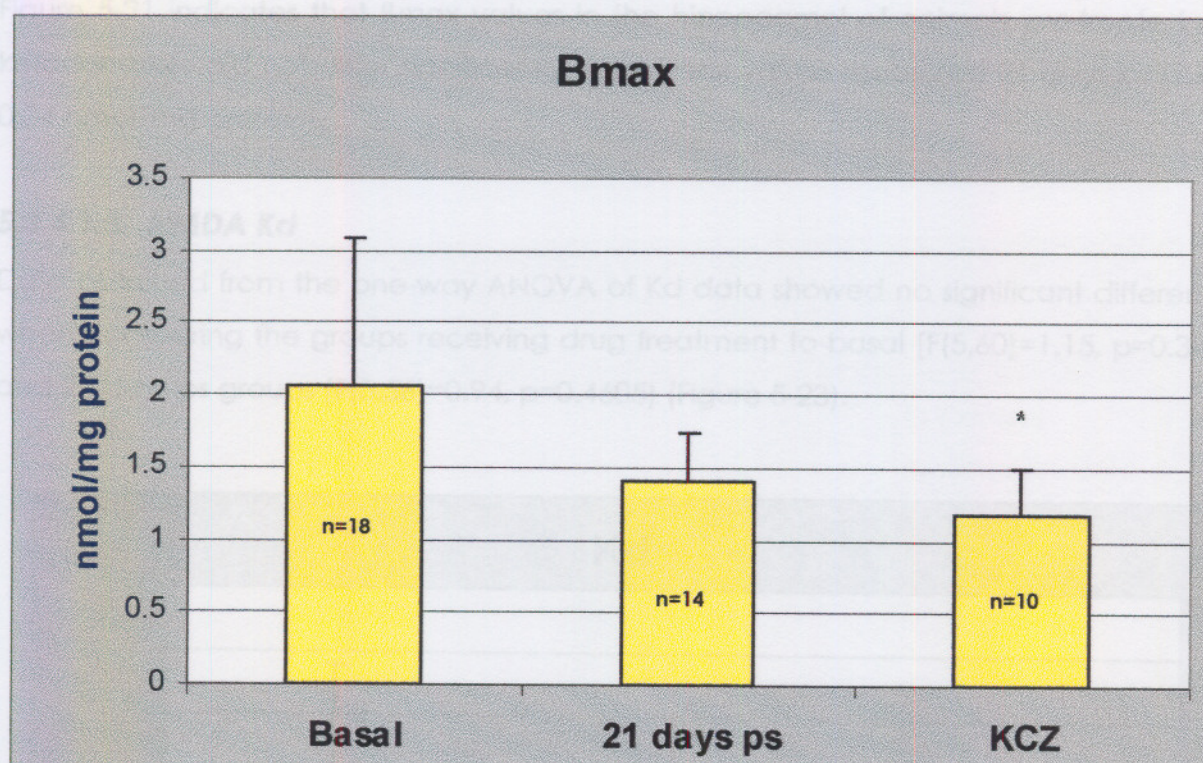

Figure 5-21 The mean \pm SEM of B_{max} values for [^3H] MK 801 binding in the hippocampi of animals pre-treated with ketoconazole, as compared to basal values and data obtained 21 days ps.

* $p<0.05$ vs basal mean (Dunnett's t-test).

According to Figure 5-21, the NMDA receptor density in the hippocampi of animals pre-treated with ketoconazole ($1.17 \pm 0.32\text{nmol/mg protein}$) were statistically significantly decreased when compared to the B_{max} values in control animals ($2.06 \pm 1.03\text{nmol/mg}$

103

Figure 5-23 The mean \pm SEM of K_d value for [^3H] MK 801 binding in animals pre-treated with ketoconazole, as compared to basal and 21 days ps data.

According to Figure 5-23, no statistically significant difference was observed when the K_d value of [^3H] MK 801 binding in the hippocampi of animals pre-treated with ketoconazole ($3.08 \pm 1.24\mu\text{M}$) was compared to basal ($4.06 \pm 3.72\mu\text{M}$) or 21 days ps ($3.55 \pm 3.11\mu\text{M}$) values.

The plasma corticosterone levels in animals exposed to TDS-stress, but receiving no drug pre-treatment, were statistically significantly decreased on 21 days ps ($1.88 \pm 4.16\text{ng/ml}$) when compared to basal plasma corticosterone levels ($43.41 \pm 31.63\text{ng/ml}$) (see par. 5.1.1.). The plasma corticosterone levels of animals pre-treated with ketoconazole, prior to TDS-stress ($34.00 \pm 18.54\text{ng/ml}$) showed a statistically significant increase when compared to plasma corticosterone levels in animals 21 days ps (Figure 5-24).

5.4. SUMMARY OF RESULTS

5.4.1. SUMMARY OF NOS-PARAMETERS

Table 5-1 Summary of NOS activity in hippocampi of control animals, animals exposed to TDS-stress, and animals pre-treated with pharmacological agents prior to exposure to TDS-stress.

(*) indicates $p < 0.05$ vs basal (Dunnett's t-test)

(•) indicates $p < 0.05$ vs basal (Tukey's test)

(#) indicates $p < 0.05$ vs 21 days ps (Dunnett's t-test)

Group	Vmax: Mean \pm SEM	Statistical significance (Vmax)	Km: Mean \pm SEM	Statistical significance	n
Basal	7.41 \pm 3.78		3.77 \pm 2.46		15
Acute	14.44 \pm 1.72	• \uparrow : basal	3.54 \pm 2.10	None	6
0 days ps	16.01 \pm 8.21	None	3.17 \pm 1.80	None	6
21 days ps	20.95 \pm 8.11	• \uparrow : basal	3.16 \pm 1.16	None	20
Flx 10mg/kg	14.58 \pm 1.73	* \uparrow : basal	3.13 \pm 2.05	None	8
Flx 20mg/kg	18.64 \pm 8.40	* \uparrow : basal	4.36 \pm 1.93	None	9
AG	5.08 \pm 3.48	# \downarrow : 21 days ps	1.20 \pm 1.47	None	10
7-NI	16.83 \pm 5.24	• \uparrow : basal	6.88 \pm 2.59	* \uparrow : basal # \uparrow : 21 days ps	8
KCZ	3.81 \pm 2.40	# \downarrow : 21 days ps	11.32 \pm 3.31	• \uparrow : basal # \uparrow : 21 days ps	8

5.4.2. SUMMARY OF NMDA RECEPTOR PARAMETERS

Table 5-2 Summary of NMDA receptor parameters in the hippocampi of control animals, animals exposed to TDS-stress, and animals receiving drug treatment prior to exposure to the TDS-model.

(*) indicates $p < 0.05$ vs basal (Dunnett's t-test)

(•) indicates $p < 0.05$ vs basal (Students t-test)

(#) indicates $p < 0.05$ vs 21 days ps (Dunnett's test)

Group	Bmax: mean ±SEM	Statistical significance (Bmax)	Kd: mean ± SEM	Statistical significance (Kd)	n
Basal	2.06 ± 1.03		4.06 ± 3.72		18
21 days ps	1.40 ± 0.34	• ↓: basal	3.55 ± 3.11	None	14
Flx 10mg/kg	1.36 ± 0.32	• ↓: basal	3.11 ± 1.26	None	10
Flx 20mg/kg	1.08 ± 0.31	• ↓: basal	2.14 ± .064	None	8
AG	1.11 ± 0.32	• ↓: basal	3.59 ± 2.22	None	10
7-NI	0.75 ± 0.12	• ↓: basal # ↓: 21 days ps	2.42 ± 0.48	None	10
KCZ	1.17 ± 0.32	# ↓: 21 days ps	3.08 ± 1.24	None	10

6. DISCUSSION

PTSD is an anxiety disorder caused by exposure to a traumatic event (DSM IV). The most profound symptoms of PTSD include a dysfunction in the mechanisms of memory (McNally, 1998) and an abnormal startle response, suggesting that cognitive changes, as well as increased anxiety, are closely linked in the behavioural and biological response to severe stress (van der Kolk, 1994).

The hippocampus is one of the most important brain areas that mediates, and in turn is affected by the stress response. Proper functioning of the hippocampus is necessary for explicit or declarative memory, and damage to this brain area will result in deficits in the laying down and recall of memories (Bodnoff, 1995; Bremner, 1999; Elzinga & Bremner, 2002; Luine, 1994; , McEwan, 1997; Sapolsky, 1996; Uno *et al*, 1989).

The hippocampus is thus an important centrepiece for integrating cognitive, neurohormonal and neuro-chemical responses to stress (Bremner, 1999; Bremner *et al*, 1999), and this makes the hippocampus a particularly vulnerable target in situations of severe stress.

6.1. GLUCOCORTICOIDS IN PTSD

Given the importance of glucocorticoids in the stress response (see par.2.3.1.), plasma glucocorticoid levels were determined in the current study for the following reasons:

- 1) to evaluate the animal model implemented in this study,
- 2) to determine the possible relationship between stress hormone levels post stress i.e. glucocorticoids and its relationship to other measured parameters, viz. NO, NMDA and GABA, and

- 3) in view of the distinct imbalance observed in the HPA axis in PTSD, to use this data to present a unified hypothesis as to the role of these parameters in the pathophysiology of PTSD.

Figure 5-1 indicates the corticosterone levels in the plasma of animals exposed to the TDS-model, measured at different time intervals post-stress. Exposure of animals to the initial stressor (restraint, forced swimming test, exposure to halothane) resulted in a statistically significant increase in plasma corticosterone levels (87.8 ng/ml) when compared to basal values (22.4 ng/ml).

The finding of increased corticosterone levels after exposure to the acute triple stressor is consistent with data found in the literature, indicating that exposure to an acute stressful event leads to a profound release of glucocorticoids from the adrenal cortex (Bremner, 1999; Harvey *et al*, 2003; Heim & Nemeroff, 1999).

The alterations found in corticosterone release after application of TDS-stress are of particular interest. Acute stress was found to result in increased corticosterone levels, but were decreased below basal values when measured 21 days after exposure to TDS-stress. This is in accordance with profound suppression of glucocorticoid levels as observed in patients with PTSD (see par.2.1.3.). The implication of the decreased corticosterone levels will be discussed later in this section. The TDS-model is thus successful in mimicking an important endocrine response characteristic of PTSD. The results in this study involving biochemical and neuroreceptor alterations in the hippocampus after TDS-stress, may thus have significant reference to PTSD.

Glucocorticoids have direct effects on memory function, while hippocampal damage is associated with direct exposure of the hippocampus to glucocorticoids (Bremner *et al*, 1999). Adverse effects of glucocorticoids on the hippocampus include the inhibition of neurogenesis. The result is an impairment in the ability of neurons to survive coincident insults, thereby worsening the neurotoxicity of seizures, hypoxia-ischemia, metabolic poisons, hypoglycaemia, and oxygen radical generators, while sufficient exposure to excessive glucocorticoids is neurotoxic (Sapolsky, 2000a). Although the hippocampus

regulates glucocorticoid release through inhibitory effects on the HPA-axis (Bremner, 1999; Bremner *et al*, 1999), hippocampal damage would result in disruption of this negative feedback loop, increasing the exposure of the hippocampus to glucocorticoid toxicity (Heim & Nemeroff, 1999; Nutt, 2000; Sapolsky, 2000a; Sapolsky, 2000b).

The profound effect of glucocorticoids on hippocampal volume is clearly illustrated in patients with Cushing's disorder, with smaller hippocampal volumes being reported in these patients (Starkman *et al*, 1992). Similarly, patients with PTSD have reduced hippocampal volumes which can, at least in part, be ascribed to increased levels of glucocorticoids as a result of trauma-exposure (Sapolsky, 2000).

Despite the implications for glucocorticoid-induced hippocampal damage in stress and anxiety disorders, glucocorticoids may not be solely responsible for the hippocampal damage and subsequent memory deficits observed in PTSD. PTSD differs from other anxiety disorders in that it is not associated with increased glucocorticoid levels, but with a decrease in glucocorticoid levels below basal values (Boscarino, 1996; Heim *et al*, 2000; Yehuda, 1996; Yehuda, 1997).

As alluded to earlier, this study (Figure-5-1) describes a significant decrease in plasma glucocorticoid levels 21 days after exposure of animals to the TDS-model (22.44 ng/ml basal value compared to 0.94 ng/ml measures 21 days ps), despite an initial increase immediately post-stress. While in agreement with clinical data, it raises the important question as to how corticosterone is involved in post-stress biobehavioural changes, and whether other mediators are involved in the apparent atrophy of the hippocampus. Indeed, this paradox in corticosterone and hippocampal dysfunction is emphasised in a recent study where TDS-stress was found to evoke a decrease in plasma corticosterone together with profound decreases in cognitive and spatial memory functions (Harvey *et al*, 2003).

Literature however, clearly implicates that increased levels of glucocorticoids are associated with hippocampal damage. PTSD is an anxiety disorder associated with decreased levels of glucocorticoids and, although the massive release of

glucocorticoids during exposure to trauma results in hippocampal atrophy (Bremner, 1999; Sapolsky, 2000b; Starkman *et al*, 1992), PTSD is a disorder that develops and worsens over time (Bremner, 1999b). It is thus possible that massive glucocorticoid secretion, due to acute trauma exposure, is only the first step in a cascade of events leading to neurodegeneration and hippocampal atrophy with subsequent memory deficits as observed in PTSD. Indeed, a previous study describes complex interplay between corticosterone receptors and modulation of hippocampal long-term potentiation (Korz & Frey, 2003).

6.2. THE GLUTAMATERGIC-NMDA PATHWAY IN PTSD

Although glutamate levels were not measured in this study, glutamate plays an important role in both glucocorticoid- and NO-induced neurotoxicity. Both stress and glucocorticoids have been found to increase glutamate concentrations in the hippocampal synapse (Nutt, 2000; Sapolsky, 2000b), while glutamate appears to be a prime mediator of glucocorticoid-induced neurotoxicity (Sapolsky, 2000b). Stress and glucocorticoids not only increase glutamate concentrations in the hippocampus, but glucocorticoids also selectively increase glutamate accumulation in response to excitotoxic insults in this brain region (Sapolsky, 2000a). Thus, hippocampal damage resulting from the effects of increased levels of glucocorticoids due to trauma exposure, will further elevate levels of glutamate, thus potentiating the neurotoxic process. It is thus clear that, while increased levels of glucocorticoids may initiate hippocampal damage, it also activates other neurotoxic pathways that may drive neuronal damage over a protracted period after the traumatic event.

6.2.1. NMDA RECEPTOR DENSITY IN PTSD

Glutamate acts through multiple receptor classes, located on virtually all neurons in the vertebrate nervous system. Alterations of glutamatergic and NMDA receptor functions have been proposed to play a role in the aetiology of PTSD in humans (Dawson & Dawson, 1996; Harvey, 1996; van der Kolk, 1994). This receptor is involved in the normal processes of memory encoding and one of the hypothesis of PTSD states that overstimulation of the NMDA receptor leads to the formation of strongly ingrained emotional memories, as observed in PTSD (Nutt, 2000). Activation of the NMDA receptor causes mobilization of free cytosolic

calcium. Calcium enters the neuron through NMDA- and voltage-gated channels, as well as being released from intracellular organelles. This mobilization of calcium activates the long-term changes in synaptic excitability that probably constitutes memory (Sapolsky, 2000a). High levels of calcium are however toxic to cells and has been found to induce cytotoxic cell death (McCaslin & Oh, 1995; Nutt, 2000). The NMDA receptors are thus strongly implicated in both memory, but also in hippocampal neurodegeneration.

The decrease in NMDA receptor density (Figure 5-4), as observed in this study, is thus a very important observation for two reasons. First, this may have functional relevance as a possible neuroprotective mechanism to counteract the neurotoxicity due to NMDA receptor overstimulation. Secondly, this response may represent a negative NMDA receptor downregulation in response to high circulating glutamate levels. As discussed earlier, exposure to trauma results in increased levels of glutamate in the central nervous system, thus leading to overstimulation of the NMDA receptor and further enhancing the cascade of events set in motion by increased glucocorticoid action in the hippocampus.

The literature confirms this decrease in NMDA receptor density as a possible form of neuroprotection. Previous studies have found that inhibition of glutamate re-uptake, resulting in increased glutamate levels, leads to a decrease in NMDA receptor density (Cebers *et al*, 1999). It has been hypothesized that, in the face of elevated extracellular glutamate, neurons might downregulate or alter the NMDA receptor density in order to decrease sensitivity to excess glutamate (Naskar & Dreyer, 2001). Thus, glutamatergic insults set in motion events that act protectively to decrease NMDA receptor density (Sapolsky, 2000a).

However, excess glutamate release alone after trauma exposure may not be the only factor contributing to the observed decrease in NMDA receptor density. Indeed, glutamate is a trigger for many down-stream events that may be the messengers provoking an imbalance between inhibitory (GABA) and excitatory (glutamate) pathways in the brain.

Centrally, activation of the NMDA receptor has been strongly linked with the rapid generation of NO in neurons (McCaslin & Oh, 1995). NO regulates NMDA receptor activity resulting in decreased NMDA receptor mediated events (Harkin *et al*, 1999). Thus, NO-mediated decrease in NMDA receptor density may represent another plausible neuroprotective mechanism. NO is a free radical, such that overstimulation of the NMDA receptor and high levels of NO can result in cell death. Several studies have found that NO exerts an inhibitory effect on NMDA receptor function (Tanaka *et al*, 1993; Zanelli *et al*, 2002) and may thus underlie the reduced NMDA density observed. These conclusions become more emphatic in par.6.3. where the effects of TDS-stress on NOS are discussed.

The decrease in NMDA receptor number, as observed in the hippocampus after exposure to the TDS-model, might thus be a possible form of neuroprotection resulting from a combination of different contributing factors.

6.3. NO IN PTSD

The results thus far have implicated an initial role for glucocorticoids, as well as glutamate in the aetiology of PTSD. As discussed earlier, PTSD is associated with a decrease in glucocorticoid levels after an initial increase due to trauma, with the observed decrease in NMDA receptor density representing a possible neuroprotective mechanism against glutamatergic insults. Despite the implications of these findings, PTSD is a disease that develops and worsens over time (Kaplan *et al*, 1994; NCPTSD, 2000), thus implying that there are possibly other mechanisms of neurotoxicity and neurodegeneration involved in the aetiology of this disorder.

Glutamatergic stimulation of NMDA receptors has been found to activate NOS, resulting in NO-production (Garthwaite, 1991; Naskar, 2001). Literature indicates an important role for NO in anxiety-related disorders. High concentrations of NOS are found in brain regions involved in the modulation of anxiety and defensive behaviour (Vincent & Kimura, 1992), and exposure to stressful stimuli has been found to induce the activation of NO-producing neurons in those brain regions (Krukoff & Khalili, 1997).

Within the central nervous system, and under normal conditions, NO functions as an important physiological signalling molecule. However, under certain circumstances, NO-synthesis may be excessive such that NO becomes neurotoxic (Bolanos, 1997). NO is a free radical and has been linked to neurodegeneration. Although the exact mechanism explaining neuronal cell death following NO exposure is still a matter of debate, it is clear that DNA damage, lipid peroxidation, and energy depletion may contribute to such neurotoxicity (Cuzzocrea, 2001).

Although NO has been linked to anxiety (Krukoff & Khalili, 1997; Vincent & Kimura, 1992), there is no evidence in the literature implicating a role for NO in PTSD. This indicates the importance of the results found in this study (referring to Figure 5-2) where a statistically significant increase was noted in the speed of reaction (V_{max}) of NOS in the hippocampus of animals exposed to the TDS-model. This increase in NOS-activity was observed after experimental animals were exposed to the initial stressor, after re-exposure to the forced swimming test, and up to 21 days after exposure to the TDS-model.

These results have far reaching implications, indicating a protracted elevation in NO-production in the hippocampus after exposure to trauma. While, under normal circumstances, NO has a half-life of approximately 7 seconds (McCaslin & Oh, 1995), excess formation of NO can result in the formation of peroxynitrite, a long-lived and strong oxidant (McCaslin & Oh, 1995). NO and peroxynitrite can interact with polyunsaturated fatty acids resulting in lipid peroxidation, a well-established mechanism of cellular injury (Lewen *et al*, 2000).

The results from this study thus indicate a possible role for NO in the hippocampal degeneration and subsequent memory deficits observed in PTSD and also after TDS-stress (Harvey *et al*, 2003). Although NO is not the only contributing factor in the neurotoxicity, it may contribute to the neurodegeneration initiated by glucocorticoids and glutamate. It is, however, important to note that NO seems to play a dual role in the central nervous system involving both neuroprotection and neurotoxicity. While increased levels of NO have been found to result in decreased NMDA receptor density (Harkin *et al*, 1999), NO has also been found to inhibit NMDA receptor-mediated GABA release (Moller *et al*, 1995), thus leaving

the excitotoxic effects of glutamate unopposed. Similar findings regarding the influence of NO on GABA and NMDA receptor density, were also observed in this study.

While the neurotoxic potential of glutamate in stress and anxiety disorders has been implicated previously (Fonnum & Hassel 1995), the possible role for GABA in PTSD is understated.

6.4. GABA IN PTSD

GABA pathways play an important role in regulating normal affective state (Shiah and Latham, 1998), and form an integral part of the stress response (Nutt, 2000). Glutamate stimulation of the NMDA receptor stimulates GABA interneurons to release GABA (Nutt, 2000). Simultaneous release of excitatory and inhibitory neurotransmitters plays a pivotal role in homeostasis: while the glutamatergic input is always excitatory, GABA input is inhibitory. A fine balance between excitatory and inhibitory amino acids in the brain prevents excessive levels of excitatory transmission from leading to adverse consequences, such as seizures (Nutt, 2000). Proof of concept for the protective role of GABA in PTSD is that prolonged loss of consciousness following a terrifying event appears to protect against the later development of PTSD (Adler, 1993).

If GABA plays a neuroprotective role in the central nervous system by opposing excitotoxic insults resulting from glutamate, what is the status of GABA in PTSD, and why does GABA not protect against neurotoxic insults resulting in hippocampal damage and memory deficits seen in PTSD? People with panic disorders have been found to have abnormally low levels of GABA (Goddard *et al*, 2001). It is, however, important to note that there are also studies implying an increase in GABA after stress (Engelman *et al*, 2002), implying that the role for GABA in anxiety disorders is not yet fully understood. GABA occupies a critical role in inhibiting glutamatergic transmission via pre-synaptic GABA-B heteroreceptors (Yamada *et al* 1998). Swim stress-induced GABA release in the hippocampus is potentiated by NO (Engelman *et al*, 2002), suggesting an important protective mechanism to curb excessive glutamate-NOS activation. NO exerts inhibitory effects on NMDA receptor function (Tanaka *et al*, 1993; Zanelli *et al*, 2002) and may underlie the

reduced NMDA receptor density observed in this study. Indeed, this may have added importance under conditions of attenuated GABA levels, as evinced in this study. NO also inhibits NMDA receptor-mediated GABA release (Moller et al, 1995), thus providing a plausible link between raised NOS activity, reduced NMDA receptor density and attenuated hippocampal GABA levels observed in this study. Stress, such as forced swimming, evokes GABA release in the hippocampus (Engelmann et al, 2002), while GABA attenuates excessive glutamatergic activity in the brain (Yamada et al, 1998). Moreover, GABA exerts important regulatory control in the stress axis (Cullinan and Wolfe, 2000).

Results obtained from this study (Figure 5-6) indicate a statistically significant decrease in the concentration of GABA in the hippocampus of animals immediately after exposure to the initial stressor (88.03 μ g/ml), after exposure to the re-stress session (112.86 μ g/ml), and up to 21 days after exposure to the TDS-model (83.71 μ g/ml), when compared to basal values of GABA levels in the hippocampus (185.93 μ g/ml).

Thus, the decrease in GABA levels observed in this study can be corroborated with findings in the literature. Alterations in the GABA system have been linked to the pathophysiology of anxiety disorders (Lydiard, 2003), as patients with panic disorder appear to have lower brain levels of GABA than healthy controls (Goddard et al, 2001).

From the aforementioned discussion (par.6.2.1.) it is clear that increased levels of glucocorticoids, due to trauma exposure, results in excessive release of glutamate. Literature suggests that excessive glutamate release can, in part, be ascribed to a down-regulation of the GABA-system, allowing an excessive activation of the glutamate system, resulting in the laying down of traumatic memories (Nutt, 2000; Sapolsky, 2000a). The decrease in GABA levels, as observed in this study, suggests that the excitotoxic action of glutamate, after trauma exposure, are left unopposed, thus contributing to neurotoxicity and hippocampal neurodegeneration, and thus may have relevance for the hippocampal damage observed in PTSD.

Part of the neuroprotective role of GABA is to prevent excessive NMDA receptor activation, especially through inhibition of glutamatergic transmission via activation of GABA-B heteroreceptors (Yamada *et al*, 1998). Alterations in glutamate-NMDA receptor mediated neurotransmission may represent a crucial component of PTSD symptomatology (Dawson & Dawson, 1996; Harvey, 1996; Skolnick, 1999; van der Kolk, 1994).

6.5. EFFECTS OF PHARMACOLOGICAL INTERVENTION ON NO

The aforementioned results indicate that increased levels of NO may play a role in the aetiology and pathophysiology of PTSD. An important question arising from these observations is whether the increase in NOS-activity, found in animals exposed to the TDS-model, can be prevented or reversed and what the effect of possible pharmacological intervention on the increase in NOS-activity would be on the development of PTSD.

Considering the inseparable association between NMDA and NOS, the following drugs were evaluated with respect to their effect on NOS-activity and NMDA receptor density in the hippocampus:

- Fluoxetine: a selective serotonin reuptake inhibitor. This drug is currently indicated in the treatment of PTSD, and acts to selectively increase synaptic levels of serotonin.
- 7-nitroindazole: a nNOS inhibitor.
- Aminoguanidine: an iNOS inhibitor.
- Ketoconazole: an inhibitor of adrenal glucocorticoid synthesis.

6.5.1. FLUOXETINE

Despite their widely accepted actions on monoamine uptake, all currently marketed antidepressant classes, including fluoxetine, modulate the NMDA class of glutamate receptors, and evidence suggests that glutamate may present the final pathway by which presently used antidepressants mediate their psychomodulatory action (Dawson & Dawson, 1996; Harvey, 1996; Skolnick, 1999). Moreover, a recent study has found that antidepressants of various classes, including SSRI's, like fluoxetine, inhibits hippocampal NOS (Wegener *et al*, 2003).

As discussed previously, this study found an increase in the V_{max} levels of NOS (Figure 5-2; par.6.3.), suggesting an increase in NO-levels in the hippocampus of animals exposed to the TDS-model. Subsequently, two groups of animals received pre-treatment with fluoxetine (one group received 10mg/kg/day, and the other 20mg/kg/day) to determine the possible intervention on this observed increase in NOS-activity.

According to the results found in this study (Figure 5-7), the V_{max} levels in stressed animals receiving fluoxetine pre-treatment (both 10mg/kg/day and 20mg/kg/day), were significantly higher when compared to basal values. However, fluoxetine pre-treatment had no significant effect on the observed increase in NOS-activity in the hippocampi of animals exposed to the TDS-model. The K_m values (Figure 5-8) for NOS in the hippocampi of stressed animals treated with fluoxetine (both 10mg/kg/day and 20mg/kg/day) did not differ significantly when compared to both basal and 21 days ps values, and all the observed K_m values were found to be in the normal range of 2-20 μ M (Bredt & Schmidt, 1996). As the results indicate no change in the affinity of the enzyme for its substrate, L-arginine, the observed increase in enzyme speed (Figure 5-7) may be ascribed to activation of an increased enzyme number. These alterations in NOS-activity will thus ultimately result in increased levels of NO in the hippocampi of all animals exposed to the TDS-model, despite pre-treatment with fluoxetine.

Although there are studies in the literature that have found that serotonergic antidepressants, like fluoxetine, to decrease the activity of NOS in the hippocampus (Finkel *et al*, 1996; Wegener *et al*, 2003), the observed paradoxical results indicate that neither the exact mechanism of action of antidepressants on NOS, nor their mechanism of action in PTSD are fully understood. Clearly further research is indicated.

An important observation of this study was the decrease in NMDA receptor density in the hippocampi of animals exposed to TDS-stress (Figure 5-4).

NMDA receptor binding in the hippocampi of stressed animals treated with fluoxetine (both 10mg/kg/day and 20mg/kg/day), was found to be significantly

decreased when compared to basal values. These data are in agreement with earlier studies on imipramine (Harvey *et al*, 2002) as well as other antidepressants (Steward & Reid, 2002). Various studies have suggested that this effect represents one of a number of putative neuroprotective actions of chronic antidepressant use, and that severe untreated depression represents a neurodegenerative process (Harvey *et al*, 2003b). However, no statistically significant differences were observed when compared to the hippocampi of animals exposed to TDS-stress without prior drug treatment (Figure 5-9). No statistical significant differences were observed when comparing Kd-values of NMD-receptor binding in the hippocampi of animals pre-treated with fluoxetine 10mg/kg/day and 20mg/kg/day, to Kd values in the hippocampi of control animals and animals receiving no drug treatment prior to exposure to TDS-stress (Figure 5-10).

It is important to note that, as discussed earlier, the decrease in NMDA receptor density may be a form of neuroprotection against neurotoxic insults evoked by increased levels of glutamate or NO. The results in this study found that fluoxetine did not alter the increase in NOS-activity in the hippocampus due to TDS-exposure, suggesting its putative neuroprotective actions do not involve NOS, yet still strengthen the proposal that its neuroprotective actions involve primarily a decrease in NMDA receptor density. These results also signify the dual role for NO: while the increased levels of NO are neurotoxic, increased NO also results in decreased NMDA receptor density to try and protect against these excitotoxic insults.

To conclude, pre-treatment with fluoxetine did not alter or inhibit the biochemical changes observed in the hippocampi of animals exposed to the TDS-model. It is however, important to remember that PTSD is a complex disease involving various neurotransmitter systems, and fluoxetine may influence any number of these systems by, up till now, unexplained mechanisms. It is also well recognized that SSRI's are at best only 70% effective (Stein *et al*, 2000). Although the exact dysregulation in the serotonergic function is not known, several animal models have suggested that central serotonergic activity may play a role in PTSD (Ellingrod, 1996; Harvey *et al*, 2003), indicating only one of a range of possible

alternative mechanisms through which fluoxetine may exert its positive effect in the treatment of PTSD.

6.5.2. 7-NITROINDAZOLE

Hitherto, results are strongly suggestive of a role for NO as one of several possible neurotoxic mechanisms implied in the aetiology of PTSD. NO acts as a neural messenger after nNOS activation, but also elicits pathogen killing properties after activation of iNOS (Forsterman *et al*, 1995; McCaslin & Oh, 1995). Moreover, recent evidence has indicated that acute restraint stress increases the expression of iNOS in the hippocampus (Madrigal *et al*, 2001), while De Oliveira and colleagues (2000) described an increased expression of nNOS after restraint-stress. Since iNOS is induced over time and produces increased concentrations of NO over a substantial period, it would be imperative to identify the isoform of NOS responsible for the increased NOS-activity observed in this study. Subsequently, a nNOS inhibitor and an iNOS inhibitor were evaluated to determine their effects on the NMDA-NOS pathway changes, as observed in this study, after exposure of animals to TDS-stress. 7-nitroindazole, a putative selective inhibitor of neuronal NOS (Moore *et al*, 1993a; Moore *et al*, 1993b; Zhang, 1995), was first to be assessed.

nNOS is a calcium-dependant subtype of the NOS family of enzymes. Calcium and calmodulin bind irreversibly to this NOS-subtype, producing receptor-regulated pulses of NO, and is primarily involved in the neuromodulation and neurotransmission process (McCaslin & Oh, 1995). nNOS is inactive until intracellular calcium levels increase, which binds to calmodulin, and the resulting calcium-calmodulin complex subsequently binds to and activates NOS (Lowenstein *et al*, 1994). Calcium necessary to activate this process, enters the cell through NMDA receptor gated ion channels and the NMDA receptor has been strongly linked with the rapid generation of NO in neurons in the central nervous system (McCaslin & Oh, 1995). This has lead to the hypothesis that increased levels of glutamate, due to trauma exposure, will lead to increased activation of the NMDA receptor, resulting in increased synthesis of NO, with subsequent effects on processes such as neuronal survival, plasticity and cellular

memory. The latter is of particular relevance to the altered mnemonic function characteristic of PTSD.

If this hypothesis is correct, the increased NOS-activity, as observed in this study after TDS-exposure, should be inhibited by the selective nNOS enzyme inhibitor, 7-nitroindazole.

Results obtained from this study (Figure 5-15), however, indicate that treatment of animals with 7-nitroindazole prior to TDS-exposure, did not significantly alter the changes observed in NOS-activity; the V_{max} values in the hippocampi of animals pre-treated with 7-nitroindazole remained statistically significantly increased above basal values, but there were no significant differences when comparing these values to V_{max} -values in the hippocampi of animals exposed to the TDS-model without prior drug treatment. According to the results in Figure 5-16, a statistical significant increase was observed in the K_m values of NOS in the hippocampi of animals receiving 7-nitroindazole pre-treatment prior to TDS-exposure, when compared to the K_m values of NOS in the hippocampi of animals receiving no drug treatment prior to TDS-exposure. This significant difference was also noted when comparing the K_m values of 7-nitroindazole pre-treatment to basal K_m values. Although all the K_m values in Figure 5-16 were in the reported K_m -range for the NOS enzyme, the increase in K_m value observed after pre-treatment with 7-nitroindazole indicates a decrease in the affinity of the NOS-enzyme for its substrate L-arginine. However, the V_{max} values for NOS in the hippocampi of animals pre-treated with 7-nitroindazole was statistically significantly increased when compared to basal values, possibly indicating that an increased number of enzyme was activated, thus still resulting in an increased NO-production, despite the decrease in enzyme affinity.

Literature indicates that NO, synthesized through activation of the nNOS isoform, is released intermittently in small amounts with the primary function of transmitting signals in the central nervous system (Lowenstein *et al*, 1994). As mentioned earlier, NO has a half-life of about 7 seconds (McCAslin & Oh, 1995) and is quickly inactivated after having transmitted a signal. Excess amounts of NO, however, form unstable intermediates, that are implicated in neurotoxicity. Normal

functioning of the nNOS enzyme would thus not result in excess amounts of NO, or in neurotoxic insults.

Another important fact is that synthesis of NO by nNOS is under regulation of the NMDA receptor (McCaslin & Oh, 1995), while NO can regulate the NMDA receptor (McCaslin & Oh, 1995). According to Figure 5-17, the NMDA receptor density measured in the hippocampi of animals receiving 7-nitroindazole treatment prior to exposure to the TDS-model (0.72nmol/mg protein) was statistically significantly decreased when compared to both NMDA receptor density in the hippocampi of control animals (2.06nmol/mg protein) and NMDA receptor density in the hippocampi of animals receiving no drug treatment prior to TDS-exposure (1.396nmol/mg protein). No significant differences were observed when comparing the K_d values for NMDA-binding in the hippocampus between these 3 groups (Figure 5-18).

This observed decrease in NMDA receptor density has been ascribed to a possible form of neuroprotection since NO has been found to downregulate the NMDA receptor in a negative feedback loop (McCaslin & Oh, 1995). Treatment of stressed animals with 7-nitroindazole amplified the decrease in NMDA receptor density, already induced by TDS-stress. Although no previous studies in literature could be found indicating a direct effect of 7-nitroindazole on NMDA receptor density, it cannot be excluded that 7-nitroindazole possibly decreases NMDA receptor density through a still unknown mechanism of action.

The decrease in NMDA receptor density further implies that, as the synthesis of NO by nNOS is under receptor regulation (McCaslin & Oh, 1995), a decrease in NMDA-receptor density will result in a subsequent decrease in nNOS-activation and thus a decrease in NO levels. This study, however, did not find a decrease in NOS-activity, indicating that nNOS may not be involved in the increased NOS-activity observed after TDS-stress.

The results obtained from treatment with 7-nitroindazole indicate that the increased NOS-activity, measured in the hippocampus of animals exposed to TDS-

stress, is not due to overstimulation of nNOS, but probably due to stimulation of another NOS-isoform.

6.5.3. AMINO GUANIDINE

Aminoguanidine is a selective inhibitor of the inducible form of NOS (Joly, 1994; Misko, 1993). iNOS differs from nNOS in that it is a calcium-independent enzyme, producing NO in a sustained manner (Gellar & Billiar, 1998; Marletta, 1993; Stuehr *et al*, 1997). Most cells are capable of expressing iNOS after stimulation by cytokines (Forsterman *et al*, 1995).

The results obtained from this study (Figure 5-11) indicate a decrease in NOS-activity in the hippocampi of stressed animals pre-treated with aminoguanidine, when compared to animals exposed to TDS-stress alone. The Vmax values for NOS in the hippocampi of stressed animals pre-treated with aminoguanidine were in the same range as basal values. As indicated in Figure 5-12, no statistical significant differences were observed when comparing the Km values of NOS in the hippocampi of stressed animals pre-treated with aminoguanidine, to animals exposed to the TDS-model alone, and control animals. All the observed Km values were in the normal range of 2-20 μ M (Bredt & Schmidt, 1996). As the affinity for the NOS enzyme for its substrate did not change, the decrease in Vmax observed after aminoguanidine pre-treatment, when compared to 21 days ps, indicate that a smaller amount of enzyme were activated, thus resulting in decreased formation of NO, when compared to the rate of synthesis of NO in the hippocampus of animals exposed to the TDS-model.

The importance of these results, in conjunction with the results obtained earlier using the nNOS inhibitor, 7-nitroindazole, is the fact that iNOS and not nNOS, is more likely to be the NOS isoenzyme that is preferentially activated after TDS-stress. This observation is in accordance with early studies suggesting that, following acute stress, NO is mainly produced through constitutive NOS, while iNOS may play an important role during chronic stress (Homayoun, 2002). Since PTSD represents a form of chronic stress due to flashbacks and re-experiencing, these data are of major significance. Moreover, that NOS-activity was increased over a sustained period has relevance for hippocampal damage: iNOS produces NO in a

sustained manner, thus producing increased levels of NO that will undergo various chemical reactions, resulting in the formation of strong oxidant species e.g. peroxynitrite (see par.3.1.1.), subsequently resulting in neurotoxicity.

Implicating iNOS in the behavioural response to TDS-stress and hence in the aetiology of PTSD, also provides a very important link with the role of glucocorticoids in PTSD. iNOS is activated by cytokines (Forsterman *et al*, 1995) and cytokines are pivotal modulators of inflammatory processes (Campbell *et al*, 2003a; Campbell *et al*, 2003b). Psychological stress in humans is associated with increased secretion of pro-inflammatory cytokines, such as interleukin-6 (Maes *et al*, 1999). In studies done to determine the plasma and cerebrospinal fluid interleukin-6 concentrations in patients with PTSD, high levels of cerebrospinal fluid interleukin-6 have been measured (Baker *et al*, 2001). Interleukin-6 secretion is suppressed by glucocorticoids (Baker *et al*, 2001). Both results from literature, as well as results from this study has indicated decreased glucocorticoid levels in PTSD, thus possibly resulting in increased interleukin-6 secretion, with subsequent increase in iNOS activation.

As mentioned earlier in the literature review (par.3.5.1.), possible roles of neuroprotection have been ascribed to NO, e.g. NO is able to downregulate its own synthesis (Asseury *et al*, 1993; Dawson & Dawson, 1991; Griscavage *et al*, 1995; Rogers & Ignarro, 1992; Stuehr *et al*, 1995). nNOS and eNOS may, however, be more sensitive than iNOS to the inhibiting action of NO (Griscavage *et al*, 1995). Thus, while dual roles for NO in both neuroprotection and neurodegeneration have been described in literature, the neurotoxic effects brought about in PTSD seems to outweigh the possible neuroprotective mechanisms set in place after the initial trauma.

Results in Figure 5-13 indicate that the pre-treatment with aminoguanidine resulted in significantly decreased NMDA receptor density when compared to basal values, but no significant effect were observed when compared to NMDA receptor density as observed after TDS-exposure. No significant differences were observed when comparing the K_d values for NMDA-binding in the hippocampus between these 3 groups (Figure 5-14). These results underline the involvement of

iNOS and not nNOS in PTSD, since iNOS activation is not regulated by typical neuro-receptors (McCaslin & Oh, 1995). The decrease observed in NMDA receptor density may however still be attributed to neuroprotective mechanisms, thus trying to counteract the deleterious effects of both increased levels of glutamate and NO on the hippocampus.

6.5.4. KETOCONAZOLE

Various studies have implicated glucocorticoids and overproduction of glucocorticoids in the pathophysiology of stress and anxiety disorders (Bremner *et al.*, 1999). Although PTSD differs from other anxiety disorders in that it is associated with decreased and not increased levels of glucocorticoids (Boscarino, 1996; Heim *et al.*, 2000; Yehuda *et al.*, 1996; Yehuda, 1997), glucocorticoids have been shown to play an important role in the aetiology of PTSD.

Ketoconazole is a potent inhibitor of glucocorticoid synthesis (Cohen *et al.*, 2001). For this reason, the plasma corticosterone levels were also determined in the animals receiving treatment with ketoconazole prior to TDS-exposure, in addition to determining the NOS-activity and NMDA receptor density in the hippocampus.

The results in Figure 5-24 indicate that pre-treatment with ketoconazole inhibited the increase in plasma corticosterone levels after exposure to the acute stressors but also reversed the prominent suppression noted on day 21 after exposure to the TDS-model. Inhibition of glucocorticoid release, as observed in PTSD, is possibly mediated by a gradual hypersensitization of the HPA-axis in the aftermath of the initial stressors (Yehuda *et al.*, 2000). The negative feedback of corticosterone on the HPA-axis was thus inhibited since the initial increase in glucocorticoid release, resulting from exposure to acute stress, was blocked by ketoconazole pre-treatment. Pre-treatment with ketoconazole thus resulted in plasma glucocorticoid levels, not significantly different from basal values.

The significance of this is indicated when comparing the changes observed in plasma glucocorticoid levels to NOS-activity in the hippocampi. Exposure of animals to TDS-stress resulted in increased NOS-activity in the hippocampi. Pre-treatment with ketoconazole however, inhibited this increase, and NOS-activity

observed after ketoconazole treatment, were in the same range as basal values, despite TDS-exposure (Figure 5-19). K_m values in the hippocampi of stressed animals receiving pre-treatment with ketoconazole were statistically significantly increased when compared to both basal K_m values and values for K_m measured 21 days ps (Figure 5-20). These are the first studies indicating that ketoconazole exerts a direct effect on NOS-enzymes. Although all the K_m values in Figure 5-20 were in the reported K_m range for the NOS-enzyme, there is an indication that pre-treatment with ketoconazole resulted in a decreased affinity of the NOS enzyme for its substrate L-arginine. This decrease in enzyme affinity for its substrate might thus contribute to the decreased activity of NOS, as observed after ketoconazole pre-treatment, and may represent a novel site of action of ketoconazole.

Another possible explanation for the decrease in NOS-activity after ketoconazole pre-treatment is the link that exists between glucocorticoids and cytokines (see par.6.3.1.3.) As discussed previously, the increase in NO levels observed after exposure to TDS-stress can be ascribed to iNOS and not nNOS activation. If there is no alteration in glucocorticoid levels, as observed with ketoconazole pre-treatment, this might inhibit the subsequent increase in cytokine production. iNOS is activated by cytokines, such that there will be no increased activation of iNOS resulting in increased levels of NO in the hippocampus. The possible link between glucocorticoids, cytokines and NO, as discussed in par.6.3.1.3., are underlined by these results found with ketoconazole pre-treatment.

These results underscore the possibility that the hippocampal pathology, as well as resulting biobehavioural changes observed in PTSD, cannot be ascribed to a single mechanism of neurotoxicity, but to a cascade of events triggered after trauma exposure. This assumption is strengthened by the results indicating that pre-treatment with ketoconazole did not alter the decrease observed in NMDA receptor density after TDS-exposure. Figure 5-21 indicate that NMDA receptor density in the hippocampus of animals receiving ketoconazole pre-treatment prior to TDS-exposure were significantly decreased when compared to basal values, but no significant difference was observed when compared to NMDA receptor density 21 days ps. No significant differences were observed when comparing the

Kd values for NMDA-binding in the hippocampus between these 3 groups (Figure 5-23).

The reduced NMDA receptor density described in the current study, is supportive that reduced hippocampal NMDA density is a late-emergent event evoked by TDS-stress. A sustained increase in glutamate might result in NMDA receptor down-regulation, thus setting in motion certain neuroprotective mechanisms to protect against cytotoxic insults.

Although none of the pharmacological agents seemed to have had an effect on NMDA receptor density, previous studies have found that NMDA receptors are relatively non-responsive at a time when synaptic glutamate concentrations are at their highest, and NMDA antagonists have proven to be less protective against cytotoxic insults under the conditions than anticipated (Sapolsky, 2000a).

Nevertheless, the finding that treatment with ketoconazole results in a significant decrease in NOS-activity after TDS-stress, warrants further investigation into the possible link between glucocorticoids and NO in the aetiology of PTSD.

7. CONCLUSION

7.1. SUMMARY AND CONCLUSION OF RESULTS

The most important aspects of the results obtained in this study have been summarised below.

The time-dependant sensitization model, inducing PTSD-like sequelae, is associated with:

Well defined alterations in adrenal glucocorticoid secretion over time:

- Acute exposure to severe stress and / or trauma results in increased plasma levels of glucocorticoids.
- As is typical in PTSD, TDS stress results in decreased plasma glucocorticoid levels at a time point distal to the traumatic event.

A decrease in GABA -concentration in the hippocampus:

- A decrease in the inhibitory amino acid neurotransmitter, GABA, leaves the actions of the excitatory amino acid neurotransmitter, glutamate, unopposed.

A decrease in NMDA receptor density in the hippocampus:

- The observed decrease in receptor number might be a neuroprotective mechanism to protect against possible excitatory insults, or may be a response to an increase in synaptic glutamate concentration.

An increase in NOS-activity in the hippocampus:

- NO has neurotoxic properties and has been implicated in neurodegenerative diseases.

- Targeted drug selection emphasised that the TDS-model resulted in iNOS, and not nNOS activation that is sustained for 3 weeks.
- Increased glucocorticoid secretion is one of the first steps in the pathophysiology of stress, leading to increased activation of iNOS and ultimately resulting in neurotoxicity possibly explaining hippocampal atrophy and memory deficits characteristic of animal models of PTSD and thus PTSD itself.

Drug treatment:

- Fluoxetine had no effect on the parameters measured in this study.
- 7-nitroindazole did not significantly alter parameters measured in this study, indicating that nNOS is not primarily involved in the long-term response to TDS-stress.
- Aminoguanidine inhibited the increase in NOS-activity evoked by the TDS-model, thus implicating a possible role for iNOS in the aetiology of PTSD.
- Ketoconazole inhibited the increase in NOS-activity evoked by the TDS-model, thus implicating a role for glucocorticoids in the increased iNOS activation observed in PTSD.

7.2. CONCLUSION

In conclusion, the results obtained from this study indicate that stress-restress evoked a complex neurobiological response in the hippocampus involving neuro-excitatory and neurotoxic pathways, as well as neuroinhibitory and neuroprotective responses to chronic stress. The TDS-model was found to successfully mimic endocrine changes observed in patients with PTSD, and was thus implemented to investigate the possible involvement of NO, NMDA receptors, and GABA, in the biobehavioural response to TDS and hence the aetiology of PTSD. The results indicate that stress-restress evokes a long-lasting increase in hippocampal iNOS activity that is accompanied by a reactive downregulation of hippocampal NMDA receptors and dysregulation of inhibitory GABA pathways. These perturbations may have importance in explaining the increasing evidence for stress-related hippocampal degenerative pathology and cognitive deficits seen in patients with PTSD.

7.3. FUTURE STUDIES

Results obtained from this study clearly indicate a very important role for NO in the pathophysiology of PTSD, thus presenting an area of major therapeutic opportunity. Future studies will focus on the possible neuroprotection offered by iNOS-inhibitors, as well as possible pharmacologic intervention and treatment of PTSD through pharmacological manipulation of the glucocorticoid-glutamate-iNOS pathway.

7.4. PRESENTATIONS

Results obtained in this study have been presented as follows:

- Behavioural, endocrine and pharmacological validation of a putative animal model of PTSD.

Naciti, C., Oosthuizen, F., Brand, L., Stein, D. & Harvey, B.H.

Third international conference on pharmacological and pharmaceutical sciences. Boksburg- South Africa. September, 2002

- The involvement of nitric oxide in post-traumatic stress disorder.

Oosthuizen, F., Brand, L., Stein, D. & Harvey, B.H.

Third international conference on pharmacological and pharmaceutical sciences. Boksburg- South Africa. September, 2002

- Sustained effects of a stress-restress paradigm on nitric oxide synthase activity, GABA levels and NMDA receptors in the rat hippocampus.

Oosthuizen, F., Brand, L., Stein, D.J. & Harvey, B.H.

6th International brain research organization (IBRO) congress. Prague, Czech Republic. July, 2003.

BIBLIOGRAPHY

ADAMEC, R.E., BURTON, P., SHALLOW, T. & BUDGELL, J. 1999. NMDA receptors mediate lasting increases in anxiety-like behaviour produced by the stress of predator exposure - implications for anxiety associated with posttraumatic stress disorder. ***Physiology and behaviour***, 65: 723-737.

ADLER, A. 1993. Neuropsychiatric complications in victim's of Boston's Coconut Grove disaster. ***Journal of the American Medical Association***, 123: 1098-1101.

AGRYPOLOUS, S.V., SANDFORD, J.J. & NUTT, D.J. 2000. The psychobiology of anxiolytic drugs. Part 2: pharmacological treatments of anxiety. ***Pharmacology and therapeutics***, 88: 213-227.

AKIL, H., WATSON, S.J. & YOUNG, E. 1983. Endogenous opioids: biology and function. ***Annual reviews of neuroscience***, 7: 223-255.

ALMEIDA, A., HEALES, S.J.R., BOLANOS, J.P. & MEDINA, J.M. 1998. Glutamate neurotoxicity is associated with nitric oxide-mediated mitochondrial dysfunction and glutathione depletion. ***Brain research***, 790: 209-216.

AMERICAN PSYCHIATRIC ASSOCIATION. 1994. Diagnostic and statistical manual of mental disorders (DSM-IV). 4th ed. Washington, D.C.

ANDERSEN, D.L., TANNENBERG, A.E.G., BURKE, C.J. & DODD, P.R. 1995. Development rearrangements of cortical glutamate-NMDA receptor binding sites in late human gestation. ***Developmental brain research***, 88:178-185.

ANTELMAN, S.M., KNOFF, S., KOCAN, D., EDWARDS, D.J., RITCHIE, J.C. & NEMEROFF, C.B. 1988. One stressful event blocks multiple actions of diazepam for up to at least a month. **Brain research**, 445: 380-385.

ANTELMAN, S.M., DEGIOVANNI, L.A. & KOCAN, D. 1989a. A single exposure to cocaine or immobilization stress provides extremely longlasting selective protection against sudden cardiac death from tetracaine. **Life sciences**, 44: 201-207.

ANTELMAN, S.M., KOCAN, D., EDWARDS, D.J. & KNOFF, S. 1989b. Anticonvulsant and other effects of diazepam grow with time after a single treatment. **Pharmacological and biochemical behaviour**, 33: 31-39.

ANTELMAN, S.M., CAGGIULA, A.R., KNOFF, S., KOCAN, D.J. & BARRY H. 1991a. Exposing rats to a single brief stressor two weeks earlier modifies the response to plasma. **Neuroscience**, 17: 494-496.

ANTELMAN, S.M., CAGGIULA, A.R. & KOCAN, D. 1991b. One experience with "lower" or "higher" intensity stressors, respectively enhances or diminishes responsiveness to haloperidol weeks later: implications for understanding drug variability. **Brain research**, 566: 276-283.

ANTELMAN, S.M., KOCAN, D., KNOFF, S., EDWARDS, D.J. & CAGGIULA, A.R. 1992. One brief exposure to a psychological stressor induces long-lasting, time-dependant sensitization of both the cataleptic and neurochemical responses to haloperidol. **Life sciences**, 51: 261-266.

ASSEURY, J., CUNHA, F.Q., LIEW, F.Y. & MONCADA, S. 1993. Feedback inhibition of nitric oxide synthase activity by nitric oxide. **British journal of pharmacology**, 108: 833-837.

AXELROD, J. 1984. Stress hormones, their interaction and regulation. **Science**, 224: 452-459.

- BAKER, D.G., EKHATOR, N.N., KASCOW, J.W., HILL, K.K., ZOUMAKIS, E., DASHEVSKY, B.A., CHROUSOS, G.P. & GERACIOTI, T.D. 2001. Plasma and cerebrospinal fluid interleukin-6 concentrations in posttraumatic stress disorder. ***Neuroimmunomodulation***, 9: 209-217.
- BARRINGTON, E.J.W. 1975. An introduction to general and comparative endocrinology. 2nd ed. Oxford: Clarendon Press.
- BLISS, T.V.P. & COLLINRIDGE, G.L. 1993. A synaptic model of memory: long term potentiation in the hippocampus. ***Nature***, 361: 31-39.
- BLOOM, F.E. 2001. Neurotransmission and the central nervous system. (*In* Hardman, J.G., Limbird, L.E. & Gilman, A.G., eds. Goodman and Gilman's the pharmacological basis of therapeutics, 10th ed. New York: McGraw-Hill. p. 293-320.
- BODNOFF, S.R., HUMPHREYS, A.G., LEHMAN, J.C., DIAMOND, D.M., ROSE, G.M. & MEANEY, M.J. 1995. Enduring effects of chronic corticosterone treatment on spatial learning, synaptic plasticity, and hippocampal neuropathology in young and mid-aged rats. ***Journal of neuroscience***, 15: 61-69.
- BOLANOS, J.P., ALMEIDA, A., STEWART, V., PEUCHEN, S., LAND, J.M., CLARK, J.B. & HEALES, S.J.R. 1997. Nitric oxide-mediated mitochondrial damage in the brain: mechanisms and implications for neurodegenerative disease. ***Journal of neurochemistry***, 68: 2227-2240.
- BOSCARINO, J.A. 1996. Posttraumatic stress disorder, exposure to combat, and lower plasma cortisol among Vietnam veterans: findings and clinical implications. ***Journal of consulting and clinical psychology***, 64: 191-201.
- BREDT, D.S. & SNYDER, S.H. 1989. Isolation of nitric oxide synthetase, a calmodulin-requiring enzyme. ***Proceedings of the National Academy of Sciences of the USA***, 87: 682-685.

- BREDT, D.S. & SCHMIDT, H.H.H.W. 1996. The citrulline assay. (*In* Feelisch, M. & Stamler, J.S., **eds**. *Methods in nitric oxide research*. New York: Wiley. p.249-255.
- BREMNER, J.D. 1999. Does stress damage the brain? *Biological psychiatry*, 45: 797-805.
- BREMNER, J.D., STAIB, L.H., KALOUPEK, D., SOUTHWICK, S.M., SOUFER, R. & CHARNEY, D.S. 1999. Neural correlates of exposure to traumatic pictures and sounds in Vietnam combat veterans with and without post-traumatic stress disorder: a positron emission topography study. *Biological psychiatry*, 45: 806-816.
- BUISSON, A., LAKHMECHE, N., VERRECCHIA, C., PLOTKINE, M. & BOULU, R.G. 1993a. Nitric oxide: an endogenous anticonvulsant substance. *Neuroreport*, 4: 444-446.
- BUISSON, A., MORGAILL, I., CALLEBERT, J., PLOTKINE, M. & BOULU, R.G. 1993b. Mechanisms involved in the neuroprotective activity of nitric oxide synthase inhibitor during focal cerebral ischemia. *Journal of neurochemistry*, 61: 690-696.
- BUSH, P.A., GONZALEZ, N.C. & IGNARRO, L.J. 1992. Biosynthesis of nitric oxide and citrulline from L-arginine by constitutive nitric oxide synthase present in rabbit corpus cavernosum. *Biochemical and biophysical research communications*, 186: 308-314.
- CAMERON, H.A., MCEWAN, B.S. & GOULD, E. 1995. Regulation of adult neurogenesis by excitatory input and NMDA receptor activation in the dentate gyrus. *Journal of neuroscience*, 15: 4687-4692.
- CAMPBELL, I.L., ASENSIO, V., BENEDICT, M., KINCAID, C., STALDER, A.K., LASSMANN, S., CARSON, M., MASLIAH, E. & POWELL, H.C. 2003a. Cytokines and inflammation in the CNS in transgenic mice. [Web:] <http://www.scripps.edu/research> [Date of access: June 2003].

CAMPBELL, I.L., ASENSIO, V., KINCAID, C., LASSMANN, S., STALDER, A.K., WEINKAUF, M., CARSON, M., MASLIAH, E. & POWELL, H.C. 2003b. Cytokines, chemokines, and inflammation in CNS disease in transgenic mice. [Web:] <http://www.scripps.edu/research> [Date of access: June 2003]

CEBERS, G., CEBERE, A., WAGNER, A. & LILJEUQUIST, S. 1999. Prolonged inhibition of glutamate re-uptake down-regulates NMDA receptor functions in cultures cerebellar granule cells. *Journal of neurochemistry*, 72: 2181-2190.

CHEESEMAN, K.H. & SLATER, T.F. 1993. An introduction to free radical biochemistry. *British medical bulletin*, 49: 481-493.

COHEN, H., BENJAMIN, J., KAPLAN, Z. & KOTLER, M. 2000. Administration of high-dose ketoconazole, an inhibitor of steroid synthesis, prevents posttraumatic anxiety in an animal model. *European neuropsychopharmacology*, 10: 429-435.

COLLINGRIDGE, G.L. & BLISS, T.V. 1995. Memories of NMDA receptors and LTP. *Trends in neuroscience*, 18: 54-56.

CONNOP, B.P., ROLFE, N.G., BOEGMAN, R.J., JHAMANDAS, K. & BENINGER, R.J. 1994. Potentiation of NMDA-mediated toxicity on nigrostriatal neurons by a low dose of 7-nitroindazole. *Neuropharmacology*, 33: 1439-1445.

CONNOP, B.P., BOEGMAN, R.J., BENINGER, R.J. & JHAMANDAS, K. 1996. Attenuation of malonate-induced degeneration of the nigro-striatal pathway by inhibitors of nitric oxide synthase. *Neuropharmacology*, 35: 459-465.

CONNOR, K.M., SUTHERLAND, S.M., TUPLER, L.A., MALIK, M.L. & DAVIDSON, J.R. 1999. Fluoxetine in post-traumatic stress disorder. *British journal of psychiatry*, 175: 17-22.

CROSBY, G., MAROTA, J.J. & HUANG, P.L. 1995. Intact nociception-induced neuroplasticity in transgenic mice deficient in neuronal nitric oxide synthase. *Neuroscience*, 69: 1013-1017.

CULLINAN W.E. & WOLFE, T.J. 2000. Chronic stress regulates levels of mRNA transcripts encoding β -subunits of GABA-A receptor in the rat stress axis. **Brain research**, 887: 118-124.

CUZZOCREA, S., RILEY, D.P., CAPUTI, A.P. & SALVEMINI, D. 2001. Antioxidant therapy: a new pharmacological approach in shock, inflammation, and ischemia/reperfusion injury. **Pharmacological reviews**, 53: 135-159.

DAVIDSON, R.J., ABERCROMBIE, H., NITSCHKE, J.B. & PUTNAM, K. 1999. Regional brain function, emotion and disorders of emotion. **Current opinion in neurobiology**, 9: 228-234.

DAWSON, V.L. & DAWSON, T.M. 1995. Physiological and toxicological actions of nitric oxide in the central nervous system. (In Ignarro, L. & Murad, F. **Volume eds**. Nitric oxide: biochemistry, molecular biology, and therapeutic implications. London: Academic Press. p.323-330).

DAWSON, V.L. & DAWSON, T.M. 1996. Nitric oxide neurotoxicity. **Journal of chemical neuroanatomy**, 10: 179-190.

DAWSON, V.L., DAWSON, T.M., LONDON, E.D., BREDT, D.S. & SNYDER, S.H. 1991. Nitric oxide mediates glutamate neurotoxicity in primary cortical cultures. **Proceedings of the National Academy of sciences of the USA**, 88: 6368-6371.

DAWSON, V.L., DAWSON, T.M., BARTLEY, D.A., UHL, G.R. & SNYDER, S.H. 1993. Mechanisms of nitric oxide-mediated neurotoxicity in primary brain cultures. **Journal of neuroscience**, 13: 2651-2661.

DE OLIVEIRA, R.M.W., DEL BELB, E.A., MARMEDE-ROSAB, M.L.N., PODOVANA, C.M., DEAKINC, J.F.W. & GUIMARAES, F.S. 2000. Expression of neuronal nitric oxide synthase mRNA in stress-related brain areas after restraint in rats. **Neuroscience letters**, 289: 123-126.

DONZATI, B.A. & YAMAMOTO, B.K. 1988. An improved and rapid HPLC-EC method for the isocratic separation of amino acid neurotransmitters from brain tissue and microdialysis perfusates. *Life sciences*, 43: 913-922.

DURE, L.S. & YOUNG, A.B. 1995. The distribution of glutamate receptor subtypes in mammalian CNS using quantitative in vitro autoradiography. (In Stone, T.W., ed. *CNS neurotransmitters and modulators: glutamate*. New York: CRC Press).

ELLINGROD, V. 1996. Posttraumatic stress disorder. [Web:] <http://www.vh.org/providers/conferences/cps/38.html> [Date of access: February 2002].

ELZINGA, B.M. & BREMNER, J.D. 2002. Are the neural substrates of memory the final common pathway in posttraumatic stress disorder (PTSD)? *Journal of affective disorders*, 70: 1-17.

ENGELMANN, M., WOLF, G. & HORN, T.F.W. 2002. Release patterns of excitatory and inhibitory amino acids within the hypothalamic supraoptic nucleus in response to direct nitric oxide administration during forced swimming in rats. *Neuroscience letters*, 324: 252-254.

ENNA, S.J. 1980. Basic receptor methods 1. (In Society for Neuroscience. eds. *Receptor binding techniques*. 1980 Short course syllabus. Cincinnati, Oh. p.1-69).

FARIA, M.S., MUSCARA, M.N., MORENO, H., TEIXEIRA, S.A., DIAS, H.B., DE OLIVEIRA, B., GRAEFF, F.G. & DE NUCCI, G. 1997. Acute inhibition of nitric oxide synthesis induces anxiolysis in the plus maze test. *European journal of pharmacology*, 323: 37-43.

FINKEL, M.S., LAGHRISSE-THODE, F., POLLOCK, B.G. & RONG, J. 1996. Paroxetine is a novel nitric oxide synthase inhibitor. *Psychopharmacology bulletin*, 32: 653-658.

FONNUM, F. & HASSEL, B. 1995. Glutamate synthesis, metabolism and uptake. (In Stone, T.W., ed. *CNS neurotransmitters and modulators: glutamate*. New York: CRC Press. p.19-34).

FORSTERMAN, U., KLEINERT, H., GATH, I., SCHWARTZ, P., CLOSS, E.I. & DUN, N.J. 1995. Expression and expressional control of nitric oxide synthases in various cell types. (In Ignarro, L. & Murad, F., eds. Nitric oxide: biochemistry, molecular biology, and therapeutic implications. London :Academic Press. p.171-186). (Advances in pharmacology. Vol. 34)

FRIEDMAN, M.J. 1997. Pharmacoterapy for PTSD: a status report. [Web:] <http://www.ncptsd.org/treatment/cq/v7/n4/friedman.html> [Date of use: April 2002].

GARTHWAITE, J. 1991. Glutamate, nitric oxide and cell-cell signalling in the nervous system. *Trends in neurosciences*, 14: 60-67.

GARTHWAITE, J., GARTHWAITE, H., PALMER, R.M.J. & MONCADA, S. 1989. NMDA receptor activation induces nitric oxide synthesis from arginine in rat brain slices. *European journal of pharmacology*, 172: 413-416.

GELLAR, D.A. & BILLIAR, T.R. 1998. Molecular biology of nitric oxide synthase. *Cancer metastasis reviews*, 17: 7-23.

GODDARD, A.W., MASON, G.F., ALMAI, A., ROTHMAN, D.L., BEHAR, K.L., PETROFF, O.C.A., CHARNEY, D.S. & KRYSTAL, J.H. 2001. Reductions in the occipital cortex GABA levels in panic disorder detected with ¹H-magnetic resonance spectroscopy. *Archives of general psychiatry*, 58: 556-561.

GORE, T.A. & RICHARDS, G. 2002. Posttraumatic stress disorder. [Web:] <http://www.emedicine.com> [Date of access: February 2002].

GOULD, E. & TANAPAT, P. 1999. Stress and neurogenesis. *Biological psychiatry*, 46: 1472-1479.

GRISCAVAGE, J.M., HOBBS, A.J. & IGNARRO, L.J. 1995. Negative modulation of NOS by NO and nitroso compounds. (In Ignarro, L. & Murad, F. **Volume eds.** Nitric oxide: biochemistry, molecular biology, and therapeutic implications. London:Academic Press. p.215-234.). (Advances in pharmacology. Vol. 34)

HARKIN, A.J., BRUCE, K.H., CRAFT, B. & PAUL, I.A. 1999. Nitric oxide synthase inhibitors have antidepressant-like properties in mice. 1. Acute treatments are active in forced swim test. **European journal of pharmacology**, 372: 201-213.

HARVEY, B.H. 1996. Affective disorders and nitric oxide: a role in pathways to relapse and refractoriness? **Human psychopharmacology**, 11: 309-319.

HARVEY, B.H., JONKER, L.P., BRAND, L., HEENOP, M. & STEIN, D.J. 2002. NMDA receptor involvement in imipramine withdrawal associated effects on swim stress, GABA levels and NMDA receptor binding in rat hippocampus. **Life Sciences**, 71: 43-54.

HARVEY, B.H., MCEWAN, B.S. & STEIN, D.J. 2003b. Neurobiology of antidepressant withdrawal: implications for the longitudinal outcome of depression. **Biological psychiatry**, (in press).

HARVEY, B.H., NACITI, C., BRAND, L. & STEIN, D.J. 2003a. Endocrine, cognitive and hippocampal 5-HT_{1A/2A} receptor changes evoked by a time-dependant sensitization (TDS) stress model in rats. **Brain research**, 983: 97-107.

HEIM, C. & NEMEROFF, C.B. 1999. The impact of early adverse experiences on brain systems involved in the pathophysiology of anxiety and affective disorders. **Biological psychiatry**, 46: 1509-1522.

HEIM, C., EHLERT, U. & HELLHAMMER, D.H. 2000. The potential role of hypocortisolism in the pathophysiology of stress-related bodily disorders. **Psychoneuroendocrinology**, 25: 1-35.

HOLSCHER, C. 1997. Nitric oxide, the enigmatic neuronal messenger: its role in synaptic plasticity. **Trends in neuroscience**, 20: 298-303.

HOMAYOUN, H., KHAVANDGAR, S. & DEHPOUR, A.R. 2002. The involvement of endogenous opioids and nitricoxidergic pathway in the anticonvulsant effects of foot-shock stress in mice. **Epilepsy research**, 49: 131-142..

HURESCO-LEVY, U. & JAVITT, D.C. 1998. The role of n-methyl-d-aspartate (NMDA) receptor-mediated neurotransmission in the pathophysiology and therapeutics of psychiatric syndromes. **European neuropsychopharmacology**, 8: 141-152.

IGA, Y., YOSHIOKA, M., TOGASHI, H. & SAITO, H. 1993. Inhibitory action of N-mega-nitro-l-arginine methyl ester on in vivo long-term potentiation in the rat dendrate gyrus. **European journal of pharmacology**, 238: 395-398.

IGNARRO, L.J. 1991. Signal transduction mechanisms involving nitric oxide. **Biochemical pharmacology**, 41: 485-490.

IKEDA, K., IWASAKI, Y. & KINOSHITA, M. 1998. Neuronal nitric oxide synthase inhibitor, 7-nitroindazole, delays motor dysfunction and spinal motoneuron degeneration in the wobbler mouse. **Journal of neurological sciences**, 160: 9-15.

ISHIZUKA, Y. 2000. GABA(A) and GABA(B) receptors modulating basal and footshock-induced nitric oxide release in rat prefrontal cortex. **Brain research**, 872: 266-270.

JOLY, G.A., AYRES, M., CHELLY, F. & KILBOURN, R.G. 1994. Effects of N^G-methyl-L-arginine, N^G-nitro-L-arginine, and aminoguanidine on constitutive and inducible nitric oxide synthase in rat aorta. **Biochemical and biophysical research communications**, 199: 147-154.

JONKER, L. 2001. Behavioural and neurochemical effects of acute and chronic antidepressant administration and withdrawal. Potchefstroom: PU for CHE. (Thesis – M.Sc.).

KAPLAN, H.I., SADOCK, B.J. & GREBB, J.A. 1994. Kaplan and Sadock's synopsis of psychiatry. London: Williams & Wilkens.

KERWIN, J.F. & HELLAR, M. 1994. The arginine-nitric oxide pathway: a target for new drugs. **Medical research reviews**, 14: 23-74.

KESSLER, R.C. 2000. The epidemiology, natural history and pharmacoeconomics, of social anxiety and PTSD. **European neuropsychopharmacology**, 10(S3): 185-186.

KIM, J.J. & DIAMOND, D.M. 2002. The stressed hippocampus, synaptic plasticity and lost memories. **Nature reviews**, 13: 453-462.

KIM Y. & OH, S. 2002. Changes of GABA-A receptor binding and subunit mRNA level in rat brain by infusion of NOS inhibitor. **Brain research**, 952: 246-256.

KING, J.A., ABEND, S. & EDWARDS, E. 2001. Genetic predisposition and the development of post traumatic stress disorder in an animal model. **Biological psychiatry**, 50: 231-237.

KOLB, L.C. 1987. Neurophysiological hypothesis explaining posttraumatic stress disorder. **American journal of psychiatry**, 144: 989-995.

KORZ, V. & FREY, J.U. 2003. Stress related modulation of hippocampal long-term potentiation: involvement of glucocorticoid receptors. **Presentation: 6th International Brain Reserarch Organization (IBRO) Congress**, Prague, Czech Republic.

KRUKOFF, T.L. & KHALILI, P. 1997. Stress-induced activation of nitric oxide-producing neurons in the rat brain. **The Journal of comparative neurology**, 377: 509-519.

KRYSTAL, J.H., KOSTEN, T.R., PERRY, B.D. 1989. Neurobiological aspects of PTSD: review of clinical and preclinical studies. **Behavioural therapy**, 20: 177-198.

KRYSTAL, J.H., D'SOUZA, C.D. & PETRAKIS, I.L. 1999. NMDA agonists and antagonists as probes of glutaminergic dysfunction and pharmacotherapies in neuropsychiatric disorders. **Harvard reviews of psychiatry**, 7: 125-143.

- LEWEN, A., MATZ, P. & CHAN, P.H. 2000. Free radical pathways in CNS injury. **Journal of neurotrauma**, 17: 871-878.
- LIBERZON, I., KRSTOV, M. & YOUNG, E.A. 1997. Stress-restress: effects on ACTH and fast feedback. **Psychoneuroendocrinology**, 22: 443-453.
- LIBERZON, I., LOPEZ, F., & FLAGEL, S.B. 1999. Differential regulation of hippocampal glucocorticoid receptor mRNA and fast feedback: relevance to posttraumatic stress disorder. **Neuroendocrinology**, 11:11-17.
- LOPEZ, J.F., AKIL, H. & WATON, S.J. 1999. Neural circuits mediating stress. **Biological psychiatry**, 46: 1471-1471.
- LOWENSTEIN, C.J., DINERMAN, J.L. & SNYDER, S.H. 1994. Nitric oxide : a physiologic messenger. **Annals of internal medicine**, 120: 227-237.
- LOWRY, O.H., ROSEBROUGH, N.J., FARR, A.L. & RANDALL, R.J. 1951. Protein measurement with the folin phenol reagent. **Journal of biological chemistry**, 193: 265-275.
- LUINE, V., VILLAGES, M., MARTINEZ, C. & MCEWAN, B.S. 1994. Repeated stress causes reversible impairments of spatial memory performance. **Brain research**, 639: 167-170.
- LYDIARD, R.B. 2003. The role of GABA in anxiety disorders. **Journal of clinical psychiatry**, 64: 21-27.
- MACLEAN, P.D. 1985. Brain evolution relating to family, play, and the separation call. **Archives of general psychiatry**, 42: 417-505.
- MADRIGAL, J.L.M., LIZASOAIN, I., LORENZO, P., CASTRILLO, A., BOSCA, L. & LEZA, J.C. 2001. Inducible nitric oxide synthase expression in brain cortex after acute restraint stress is regulated by nuclear factor κ B-mediated mechanisms. **Journal of Neurochemistry**, 76: 532-538.

MAES, M., LIN, A.H., DELMEIRE, L., VAN GASTEL, A., KENIS, G., DE JONGH, R. & BOSMANS, E. 1999. Elevated serum interleukin-6 and interleukin-6 receptor concentrations in posttraumatic stress disorder following accidental man-made traumatic events. **Biological psychiatry**, 45: 833-839.

MARLETTA, M.A. 1993. Nitric oxide synthase structure and mechanisms. **Journal of biological chemistry**, 268: 12231-12234.

MATÉS, J.M. 2000. Effects of antioxidant enzymes in the molecular control of reactive oxygen species toxicology. **Toxicology**, 153: 83-104.

MCCASLIN, P.P. & OH, S. 1995. Nitric oxide and glutamate receptors. (*In* Stone, T.W. ed. CNS neurotransmitters and neuromodulators: glutamate. New York: CRC Press. p.159-179).

MCEWAN, B.S., CONRAD, C.D., KURODA, Y., FRANKFURT, M., MAGARINOS, A.M. & MCKITTRICK, C. 1997. Prevention of stress-induced morphological and cognitive consequences. **European neuropsychopharmacology**, 7(suppl 3): S322-S328.

MGGOUGH, J.C. & ROOZENDAAL, B. 2002. Role of adrenal stress hormones in forming lasting memories in the brain. **Current opinion in neurobiology**, 12: 205-210.

MCNALLY, R.J. 1998. Experimental approaches to cognitive abnormality in posttraumatic stress disorder. **Clinical psychology review**, 18: 971-982.

MILLER, R.G. 1980. Simultaneous statistical inference. 2nd ed. New York: Springer-Verlag.

MISKO, T.P., MOORE, W.M., KASTEN, T.P., NICKOLS, G.A., CORBETT, J.A., TILTON, R.G., MCDANIEL, M.L., WILLIAMSON, J.R. & CURRIE, M.G. 1993. Selective inhibition of the inducible nitric oxide synthase by aminoguanidine. **European journal of pharmacology**, 233: 119-125.

- MOLLER, M., JONES, N.M. & BEART, P.M. 1995. Complex involvement of nitric oxide and cGMP at N-methyl-aspartic acid receptors regulating γ -[³H] aminobutyric acid release from striatal slices. **Neuroscience letters**, 190: 195-198.
- MONCADA, S. & HIGGS, A. 1993. The L-arginine-nitric oxide pathway. **The New England journal of medicine**, 329: 2002-2012.
- MONCADA, S., PALMER, R.M.J. & HIGGS, E.A. 1991. Nitric oxide: physiology, pathophysiology, and pharmacology. **Pharmacological reviews**, 43:109-141.
- MONCADA, S., HIGGS, A. & FURCHGOTT, R. 1997. International union of pharmacology nomenclature in nitric oxide research. **Pharmacological reviews**, 49: 137-142.
- MOORE, P.K., BABBEDGE, R.C., WALLACE, P., GAFFEN, Z.A. & HART, S.L. 1993a. 7-Nitro-indazole, an inhibitor of nitric oxide synthase, exhibits anti-nociceptive activity in the mouse without increasing blood pressure. **British journal of pharmacology**, 108: 296-297.
- MOORE, P.K., WALLACE, P., GAFFEN, Z., HART, S.L. & BABBEDGE, R.C. 1993b. Characterization of the novel nitric oxide synthase inhibitor 7-nitro indazole and related indazoles: antinociceptive and cardiovascular effects. **British journal of pharmacology**, 110: 219-224.
- NASKAR, R. & DREYER, E.B. 2001. New horizons in neuroprotection. **Survey of ophthalmology**, 45: S250-S255.
- NATIONAL CENTRE FOR PTSD. 2000. What is post-traumatic stress disorder? [Web:] <http://www.ncptsd.org/facts/index.html> [Date of access: October 2000].
- NEL, A. 2002. Aging as a contributory factor in the neurobiology of tardive dyskinesia. Potchefstroom: PU for CHE. (Thesis – M.Sc.).
- NUTT, D.J. 2000. The psychobiology of posttraumatic stress disorder. **Journal of clinical psychiatry**, 61(5): 24-29.

O'BRIEN, M. & NUTT, D. 1998. Loss of consciousness in posttraumatic stress disorder: a clue to etiology and treatment. **British journal of psychiatry**, 173: 102-104.

OLNEY, J.W. 1990. Excitotoxic amino acids and neuropsychiatric disorders. **Annual reviews of pharmacology and toxicology** 30: 47-71.

PODHORNA, J. & BROWN, R.E. 1999. Inhibition of nitric oxide synthase reduces ultrasonic vocalizations of rat pups. **European journal of pharmacology**, 382: 143-150.

PORSOLT, R.D., LE PICHON, M. & JALFRE, M. 1977. Depression: a new animal model sensitive to antidepressant treatments. **Nature**, 266: 730-732.

PORSOLT, R.D., ANTON, G., BLAVET, N. & JALFRE, M. 1978. Behavioral despair in rats: a new model sensitive to antidepressant treatments. **European journal of pharmacology**, 47: 379-391.

PRAST, H. & PHILIPPU, A. 2001. Nitric oxide as modulator of neuronal function. **Progress in neurobiology**, 64: 51-68.

QUI, J., SWEENEY, D.D., NETZEBAND, J.G. & GRUOL, D.L. 1998. Chronic interleukin-6 alters NMDA receptor-mediated membrane responses and enhances neurotoxicity in developing CNS neurons. **Journal of neuroscience**, 18: 10445-10456.

RENGASAMY, A., RAVICHANDRAN, L.V., REIKERSDORFER, C.G. & JOHNS, R.A. 1995. Inhalational anesthetics do not alter nitric oxide synthase activity. **Journal of pharmacology and experimental therapeutics**, 273: 599-604.

RICHTER-LEVIN, G. 1998. Acute and long-term behavioral correlates of underwater trauma – potential relevance to stress and post-stress syndromes. **Psychiatry research**, 79: 73-83.

- ROGERS, N.R. & IGNARRO, L.J. 1992. Constitutive nitric oxide synthase from cerebellum is reversibly inhibited by nitric oxide formed from L-arginine. ***Biochemical and biophysical research communications***, 189: 242-249.
- ROSEN, J. & FIELDS, R. 1988. The long-term effects of extraordinary trauma: a look beyond PTSD. ***Journal of anxiety disorders***, 2: 179-191.
- ROUSSEAU, D. 2003. Nitric oxide synthases. [Web:] <http://www.aecom.yu.edu> [Date of access: June 2003].
- SALTER, M., DUFFY, C., GARTHWAITE, J. & STRIJBOS, P.J.L.M. 1996. Ex vivo measurements of brain tissue nitrite and nitrate accurately reflects nitric oxide synthase activity in vivo. ***Journal of neurochemistry***, 66: 1683-1690.
- SANCHES, D.B., STEINER, A.A. & BRANCO, L.G.S. 2002. Involvement of neuronal nitric oxide synthase in restraint stress-induced fever in rats. ***Physiology and behaviour***, 75: 261-266.
- SANDERS-BUSH, E. & MAYER, S.E. 1995. 5-HT (serotonin) receptor agonists and antagonists. (In Gilman, A.G., Rall, T.W., Nies, A.S. & Taylor, P., eds. Goodman & Gillman's the pharmacological basis of therapeutics. New York: McGraw-Hill. p.249-263).
- SAPOLSKY, R.M. 1996. Why stress is bad for your brain. ***Science***, 273: 749-750.
- SAPOLSKY, R.M. 2000a. The possibility of neurotoxicity in the hippocampus in major depression: a primer on neuron death. ***Biological psychiatry***, 48: 755-765.
- SAPOLSKY, R.M. 2000b. Glucocorticoids and hippocampal atrophy in neuropsychiatric disorders. ***Archives of general psychiatry***, 57: 925-935.
- SCHMIDT, H.H.W. & WALTER, U. 1994. NO at work. ***Cell***, 78: 919-925.

SCHULTZ, J.B., MATTHEWS, R.T. & BEAL, M.F. 1995. Role of nitric oxide in neurodegenerative diseases. **Current opinion in neurology**, 8: 480-486.

SCHOLEY, A. 2002. The limbic system. [Web:] <http://www.psychology.unn.ac.uk/andrew/PY013/BBBbrainsf.htm> [Date of access: June 2002].

SHAIH, I-S. & LATHAM, L.N. 1998. GABA function in mood disorders: an update and critical evidence. **Life sciences**, 63: 1289-1303.

SIMON, E. 1998. Nitric oxide as peripheral and central mediator of temperature regulation. **Amino acids**, 14: 87-93.

SKOLNICK, P. 1999. Antidepressant for the new millennium. **European journal of pharmacology**, 375: 31-40.

SNYDER, S.H. & DAWSON, T.M. 2003. Nitric oxide and related substances as neural messengers. [Web:] <http://www.acnp.org> [Date of access: April, 2003].

SOUTHAM, E. & GARTWAITE, J. 1996. Nitric oxide-cyclic GMP pathway in brain slices. (In Parker, L. ed. *Methods in enzymology* Vol.269. London:Academic Press. p.129).

SOUTHWICK, S.M., PAIGE, S., MORGAN, C.A., BREMNER, J.D., KRYSTAL, J.H. & CHARNEY, D.S. 1999. Neurotransmitter alterations in PTSD: catecholamines and serotonin. **Seminars on clinical neuropsychiatry**, 4: 242-248.

STAM, R., BRUIJNZEEL, A.W. & WIEGANT, V.M. 2000. Long-lasting stress sensitization. **European journal of pharmacology**, 405: 217-224.

STARKMAN, M.N., GEBARSKI, S.S., BERENT, S. & SCHEINGART, D.E. 1992. Hippocampal formation volume, memory dysfunction, and cortisol levels in patients with Cushing's syndrome. **Biological psychiatry**, 32: 756-765.

- STEIN, D.J., ZINGU-DIRWAYI, N. & VAN DER LINDEN, G.J. 2000. Pharmacotherapy for posttraumatic stress disorder. **Cochrane database of systemic reviews**, CD002795.
- STEWART, C.A. & REID, I.C. 2002. Antidepressant mechanisms: functional and molecular correlates of excitatory amino acid neurotransmission. **Molecular psychiatry**, 7(S1): S15-S22.
- STUEHR, D.J., ABU-SAUD, D.L., ROUSSEAU, P.L., FELDMAN, P.L. & WANG, J. 1995. Control of electron transfer in nNOS by calmodulin, substrate, substrate analogs and NO. (In Ignarro, L. & Murad, F., eds. Nitric oxide: biochemistry, molecular biology, and therapeutic implications. London: Academic Press. p.323-342). (Advances in pharmacology. Vol. 34)
- STUEHR, D.J. 1997. Structure-function aspects in the nitric oxide synthases. **Annual reviews of pharmacology and toxicology**, 37: 339-359.
- SUTHERLAND, S.M. & DAVIDSON, J.R.T. 1994. Pharmacotherapy for PTSD. **Psychiatric clinics of North America**, 2: 409-423.
- TANAKA, T., SAITO, H. & MATSUKI, N. 1993. Endogenous nitric oxide inhibits NMDA- and kainate responses by a negative feedback system in rat hippocampal neurons. **Brain research**, 631: 72-76.
- UNO, H., TARARA, R., ELSE, J.G., SULEMAN, M.A. & SAPOLSKY, R.M. 1989. Hippocampal damage associated with prolonged and fatal stress in primates. **Journal of neuroscience**, 9: 1705-1711.
- UYS, J.D.K., STEIN, D.J., DANIELS, W.M.U. & HARVEY, B.H. 2003. Animal models of anxiety disorders. **Current psychiatry reports**, 5: 274-281.
- VALLANCE, P. & COLLIER, J. 1994. Fortnightly review biology and clinical relevance of nitric oxide. **British medical journal**, 309: 453-457.

VAN DER KOLK, B.A. 1994. The body keeps the score. [Web:] <http://www.trauma-pages.com/vanderk4.htm> [Date of access: March 2000].

VAN DER KOLK, B.A. 1995. Approaches to the treatment of PTSD. [Web:] <http://www.trauma-pages.com/vanderk.htm> [Date of access: April 2000]

VAN DER KOLK, B.A. 1997. The psychobiology of PTSD. *Journal of clinical psychiatry*, 58(9): 16-24.

VAN DER KOLK, B., Levin, P. & Lazrae, S. 1999. What psychological testing and neuroimaging tell us about the treatment of posttraumatic stress disorder by eye movement desensitization and reprocessing. *Journal of anxiety disorders*, 13: 159-172.

VERRECCHIA, C., BUISSON, A., LAKHMECHE, N., PLOTKINE, M. & BOULU, R.G. 1994. Nitric oxide and cerebral ischemia. *Annals of the New York Academy of Sciences of the USA*, 738: 341-347.

VINCENT, S.R. & KIMURA, H. 1992. Histochemical mapping of nitric oxide synthase in the rat brain. *Neuroscience*, 46: 755-784.

VOLKE, V., SOOSAAR, A., KOKS, S., BOURIN, M., MANNISTO, P.T. & VASAR, E. 1997. 7-nitroindazole, a nitric oxide synthase inhibitor, has anxiolytic-like properties in exploratory models of anxiety. *Psychopharmacology*, 131: 399-405.

WEGENER, G., VOLKE, V., HARVEY, B.H. & ROSENBERG, R. 2003. Local, but not systemic, administration of serotonergic antidepressants decreases hippocampal nitric oxide synthase activity. *Brain research*, 959: 128-134.

WILSON, K. & GOULDING, K.H. eds. 1986. A biologist's guide to principles and techniques of practical biochemistry. 3rd ed. New York:Edward Arnold.

WONG, C.M. 2002. Post-traumatic stress disorder: advances in psychoneuroimmunology. *Psychiatric Clinics of North America*, 25: 369-383.

- YAMADA, J., SAITOW, F., SATAKE, S., KIYOHARA, T. & KONISHI, S. 1998. GABA-B receptor-mediated presynaptic inhibition of glutaminergic and GABAergic transmission in the basolateral amygdala. *Neuropharmacology*, 38: 1743-1753.
- YEHUDA, R. 1997. Sensitization of the hypothalamic-pituitary-adrenal axis in posttraumatic stress disorder. *Annals of the New York academy of science*, 821: 57-75.
- YEHUDA, R. & ANTELMAN, S.M. 1993. Criteria for rationally evaluating animal models of posttraumatic stress disorder. *Biological psychiatry*, 33: 479-486.
- YEHUDA, R., BIERER, L.M., SCHMEIDLER, J., AFERIAT, D.H., BRESLAU, I. & DOLAN, S. 2000. Low cortisol and risk for PTSD in adult offspring holocaust survivors. *American journal of psychiatry*, 157: 1252-1259.
- YEHUDA, R., GILLER, E.L., SOUTHWICK, S.M., LOWY, M.T. & MASON, J.W. 1991b. Hypothalamic pituitary adrenal dysfunction in posttraumatic stress disorder. *Biological psychiatry*, 30: 1031-1048.
- YEHUDA, R., LOWY, M.T., SOUTHWICK, S.M., SHAFFER, S. & GILLER, E.L. 1991a. Increased number of glucocorticoid receptors in post-traumatic stress disorder. *American journal of psychiatry*, 144: 499-504.
- YEHUDA, R., SOUTHWICK, S.M., NUSSBAUM, G. & WAHBY, V.S. 1990. Low urinary cortisol excretion in patients with posttraumatic stress disorder. *Journal of nervous and mental disorders*, 178: 366-369.
- YEHUDA, R., TEICHER, M.H., TRESTMAN, R.L., LEVENGOOD, R.A. & SIEVER, L.J. 1996. Cortisol regulation in posttraumatic stress disorder and major depression: a chronobiological analysis. *Biological psychiatry*, 40: 79-88.
- YOSHIDA, T., LIMMROTH, V., IRIKURA, K. & MOSKOWITZ, M.A. 1994. The NOS-inhibitor, 7-nitroindazole, decreases focal infarct volume but not the response to topical acetylcholine in pial vessels. *Cerebral blood flow and metabolism*, 14: 924-929.

ZANELLI, S.A., ASHRAT, Q.M. & MISHRA, O.P. 2002. Nitration is a mechanisms of regulation of the NMDA receptor function during hypoxia. **Neuroscience**, 112: 869-877.

ZHANG, F., XU, S. & IADECOLA, C. 1995. Role of nitric oxide and acetylcholine in neocortical hyperemia elicited by basal forebrain stimulation: evidence for an involvement of endothelial nitric oxide. **Neuroscience**, 69: 1195-1204.

ACKNOWLEDGEMENTS

The student studies the sciences, not as fanciful theories, but as devotion to God- because measuring the depths of the sea and forces of fire and magnitudes of physical things leads to a reverent awe at the Creator's skill and wisdom.

I wish to thank the following people for their guidance and support throughout this study:

Dr Linda Brand, my promoter, for your invaluable guidance, continuous encouragement, and wonderful friendship. You are a true mentor to me.

Prof Brian Harvey, my co-promotor, for initiating this study, and your insights as excellent researcher.

Dr Malie Rheeders, for your encouragement, motivation and inspirational friendship.

Carla Nacifi, for your help with the animal models, and especially for your friendship throughout the study.

Johannes Bodenstein, for your friendship and support.

A special word of thanks to my **Dad** and my **Brother**, for your encouragement and continuous support.

This study was made possible by excellent assistance from the following people:
Dr Francois van der Westhuizen, from the Department of Biochemistry (P.U. for C.H.E.) for guidance with the enzyme techniques.

Mr Cor Bester and Mrs Antoinette Fick, from the Animal Research Centre, for providing the research animals, and assistance with certain procedures.

Andrew Thlaole, for assistance with the decapitation procedures.

Mr Naas van Rooyen and Mrs Petro Bergh, for obtaining the necessary chemicals.

Prof Faans Steyn, from Statistical Consultation Service (P.U. for C.H.E.) for the statistical analysis of the data.

Mrs Anriëtte Pretorius, of the Ferdinand Postma Library, for assistance with the bibliography.

The **South African Medical Research Council** for financial assistance.

...life really is generous to those who pursue their destiny...