

# Investigation into the production optimization of a dry mixing batch plant

**L Greeff**  
**20257570**

Dissertation submitted in partial fulfilment of the requirements for the degree *Magister* in **Development and Management Engineering** at the Potchefstroom Campus of the North-West University

Supervisor: Ms R Coetzee

Co-Supervisor: Prof JIJ Fick

May 2015

## **Acknowledgements**

I would like to thank my parents, André and Sarah for supporting me. I would also like to thank Jane Greeff and Aldo Holden for your assistance and support.

My sincere gratitude to the following people for their assistance:

- Ms R Coetzee
- Prof JIJ Fick
- Ms J Greeff
- Mr FA Greeff
- Ms SC Greeff

## **Abstract**

This dissertation reports the investigation and combination of optimization methodologies and the result of implementing them within a production environment.

A literature survey was conducted on the optimization methodologies Lean Manufacturing and theory of constraints (TOC).

A number of production optimization methodologies were studied and considered for application to the case study organisation. Due to the small size and relative simplicity of the operation, these methodologies had to be simplified and combined into a more relevant form.

A refractory manufacturer was used as a case study for the investigation into the optimization of the dry batch plant. Lean Manufacturing and TOC are optimization methodologies that could be employed to optimize the dry batch plant.

Tools from these methodologies were used to investigate problems identified within the production process that were causing the batching plant to perform non-optimally. A time and motion study was conducted and a process flow chart was created to understand the production process. Wasteful activities were identified using a value stream map and a flow process chart was used to visualise the movement within the production process. A 5-Why analysis was conducted to determine the root causes.

An optimization plan was created to eliminate the wasteful activities and the operational measures, that is throughput, inventory and operating expense, were used as to determine what the effect the optimization plan would have on the wasteful activities (Lean Manufacturing) found within the batching plant and the organisation.

The results of the combined effect of the optimization plan are discussed focusing on the improvements in the operational measures and the increase in profit from sales.

Future research is suggested to improve the benchmarking of the optimization plan and any future improvements that the organisation might implement.

## **Keywords**

Lean Manufacturing, theory of constraint (TOC), flow process chart, value stream map, process flow diagram, 5-Why analysis, operational measures, throughput, inventory, operating expense.

# Table of contents

<b>Acknowledgements</b> .....	<b>i</b>
<b>Abstract</b> .....	<b>ii</b>
<b>Keywords</b> .....	<b>iii</b>
<b>List of figures</b> .....	<b>vii</b>
<b>List of tables</b> .....	<b>viii</b>
<b>List of graphs</b> .....	<b>ix</b>
<b>List of abbreviations</b> .....	<b>x</b>
<b>Glossary</b> .....	<b>xi</b>
<b>1 Background and introduction</b> .....	<b>1</b>
<b>1.1 Background</b> .....	<b>1</b>
1.1.1 The organisation.....	1
1.1.2 The batching process .....	2
1.1.3 The manufacturing process.....	3
1.1.4 Quality control .....	5
1.1.5 Premixing .....	5
1.1.6 Inventory management.....	5
<b>1.2 Introduction</b> .....	<b>6</b>
1.2.1 The Lean Manufacturing philosophy .....	6
1.2.2 Problem statement .....	7
1.2.3 Research aims and objectives .....	7
1.2.4 Deliverables.....	8
1.2.5 Method of investigation .....	8
<b>2 Literature survey</b> .....	<b>9</b>
<b>2.1 Lean Manufacturing</b> .....	<b>9</b>
2.1.1 The 14 principles of Lean Manufacturing .....	9
<b>2.2 The theory of constraints (TOC)</b> .....	<b>20</b>
2.2.1 The goal .....	20
2.2.2 The definition of a constraint .....	21
2.2.3 The five focusing steps.....	21
<b>2.3 Time and motion study</b> .....	<b>23</b>
2.3.1 Normal time .....	23
2.3.2 Standard time .....	23

2.3.3	Rating factor .....	24
2.3.4	Allowances .....	25
2.3.5	Flow process chart .....	25
2.3.6	Process flow diagram .....	27
<b>2.4</b>	<b>Critical review of production optimization theory applicable to the case study organisation .....</b>	<b>30</b>
<b>3</b>	<b>Investigational procedure.....</b>	<b>31</b>
<b>3.1</b>	<b>A flow process chart.....</b>	<b>31</b>
<b>3.2</b>	<b>A value stream map .....</b>	<b>31</b>
<b>3.3</b>	<b>A process flow diagram .....</b>	<b>32</b>
<b>3.4</b>	<b>A 5-Why analysis to determine the root causes .....</b>	<b>32</b>
<b>3.5</b>	<b>The operational measures based on TOC .....</b>	<b>32</b>
3.5.1	Throughput.....	32
3.5.2	Inventory.....	33
3.5.3	Operating expenses .....	33
<b>3.6</b>	<b>Summary.....</b>	<b>34</b>
<b>4</b>	<b>Results from the investigation .....</b>	<b>35</b>
<b>4.1</b>	<b>Flow process chart .....</b>	<b>35</b>
<b>4.2</b>	<b>Value stream mapping for the production process .....</b>	<b>38</b>
4.2.1	Wasteful activities at the organisation .....	39
<b>4.3</b>	<b>The process flow diagram.....</b>	<b>40</b>
<b>4.4</b>	<b>5-Why analysis to determine the root causes.....</b>	<b>41</b>
4.4.1	Problem: Unnecessary retesting of laboratory test samples .....	41
4.4.2	Problem: Waiting for raw materials .....	41
4.4.3	Problem: Excessive movement of product .....	42
4.4.4	Problem: Rework of out-of-specification final product .....	42
<b>4.5</b>	<b>Summary.....</b>	<b>42</b>
<b>5</b>	<b>Optimization plan and estimated improvements.....</b>	<b>44</b>
<b>5.1</b>	<b>Eliminating the need to retest laboratory test samples .....</b>	<b>44</b>
5.1.1	Effect on throughput.....	44
5.1.2	Effect on inventory.....	45
5.1.3	Effect on operating expense.....	45
<b>5.2</b>	<b>Eliminating the need to wait for raw materials.....</b>	<b>46</b>
5.2.1	Effect on throughput.....	47
5.2.2	Effect on inventory.....	48
5.2.3	Effect on operating expense.....	49

<b>5.3</b>	<b>Eliminating excessive movement of product during production</b> .....	<b>49</b>
5.3.1	Effect on throughput.....	51
5.3.2	Effect on inventory.....	52
5.3.3	Effect on operating expense.....	52
<b>5.4</b>	<b>Eliminating the need to rework out-of-specification final product</b> .....	<b>53</b>
5.4.1	Effect on throughput.....	53
5.4.2	Effect on inventory.....	53
5.4.3	Effect on operating expense.....	55
<b>5.5</b>	<b>Summary</b> .....	<b>55</b>
<b>5.6</b>	<b>The prioritisation of the problems in the optimization plan</b> .....	<b>59</b>
<b>6</b>	<b>Discussion of results</b> .....	<b>60</b>
6.1	The results from the combined effect of the optimization plan .....	60
<b>7</b>	<b>Future research and continuous improvement</b> .....	<b>62</b>
7.1	Create a schedule for internal audits.....	62
7.2	Monitor the production process.....	62
<b>8</b>	<b>Conclusion</b> .....	<b>63</b>
<b>9</b>	<b>References</b> .....	<b>64</b>
<b>Appendix A: Time and motion study</b> .....		<b>68</b>
<b>Appendix B: Total expense for the organisation</b> .....		<b>70</b>
<b>Appendix C: Total production and operating hours</b> .....		<b>73</b>
<b>Appendix D: Bottom-line measures based on TOC</b> .....		<b>74</b>
<b>Appendix E: Prioritisation and buffer levels of the raw materials</b> .....		<b>75</b>

## List of figures

Figure 1: A typical concrete batching plant (Gulin Crushers, 2010) .....	2
Figure 2: Production line at the organisation (Greeff, L., 2013a).....	3
Figure 3: The mixer on the production line (Greeff, L., 2013b).....	4
Figure 4: The stitching station at the production line (Greeff, L., 2013c).....	4
Figure 5: Value stream map for software development (Liker, 2004:30).....	12
Figure 6: Traditional production on the left vs. levelled production on the right (Liker, 2004:117-119).....	14
Figure 7: The 5-Why analysis (Liker, 2004:253).....	18
Figure 8: The Westinghouse rating system (Cevikcan <i>et al</i> , 2012).....	24
Figure 9: Example of a flow process chart (The American Society of Mechanical Engineers, 1947:15).....	26
Figure 10: Example of a process flowchart (The International Organisation of Standardisation, 1985).....	27
Figure 11: Example of a process flow chart (Pigage & Ticker, 1954:16).....	28
Figure 12: Example of a process flow diagram (Pigage & Ticker, 1954:17).....	29
Figure 13: The flow process chart for the organisation .....	37
Figure 14: The value stream map for the production process .....	38
Figure 15: The process flow diagram .....	40
Figure 16: The proposed optimization of the production plant layout.....	50

## List of tables

Table 1: The effects of global operational measures on the bottom-line (Goldratt & Fox, 1986:31) .....	20
Table 2: Tools and measures used during the investigation .....	34
Table 3: The summary of the wasteful activities, root causes and proposed solutions.....	43
Table 4: The estimated effect of the optimization plan .....	56
Table 5: The effects the changes from the optimization plan would have on the operating measure .....	57
Table 6: The combined estimated effect of the optimization plan .....	58
Table 7: The prioritisation of the problems for the optimization plan .....	59
Table 8: The optimization plan priority and solutions .....	59
Table 9: Time and motion study for the organisation .....	68
Table 10: Total expense for the organisation from 2009 – 2012 (Greeff, S.C., 2012) .....	70
Table 12: Total production and operating hours for 2009 – 2012 (Greeff, S.C., 2012) .....	73
Table 12: Bottom-line measures based on TOC for 2009 – 2012 (Greeff, S.C., 2012).....	74
Table 13: Prioritisation and buffer levels of raw materials at the organisation .....	75

## List of graphs

Graph 1: The estimated combined effect on the operational measures.....	60
Graph 2: The effect of the optimization plan on profit from sales.....	61

## List of abbreviations

BD	-	Bulk density
CCS	-	Cold crushing strength
SHEQ	-	Safety, Health, Environmental and Quality
TOC	-	Theory of constraints
TPS	-	Toyota production system

## Glossary

<i>Andon</i>	A signalling system that indicates when and where assistance is needed if a problem occurs.
Bulk density	The product's particle mass divided by the volume that they occupy.
Cold crushing strength	The product's ability to resist failure under compressive load at room temperature.
Defect	A shortcoming that does not satisfy the specification.
<i>Genchi genbutsu</i>	Going personally to see what the situation is for a better understanding.
<i>Hansei</i>	Reflection on a situation and what went wrong.
<i>Heijunka</i>	The levelling out of the production workload.
Inventory	The money the system invests in purchasing items that the system intends to sell.
<i>Jidoka</i>	Autonomation, where automation implements some supervisory functions.
<i>Kaizen</i>	The philosophy or practise of continuous improvement.
<i>Kanban</i>	A signal to indicate when a system in the process is ready for more product.
<i>Muda</i>	Non-value-adding activities that include the eight forms of waste.
<i>Mura</i>	Unevenness caused by varying demand, resulting in an irregular production schedule.

<i>Muri</i>	Overburdening of people or equipment, or pushing it over its natural limit.
Non-value adding	Any process that is carried out that does not increase the product's value from the customer's perspective.
Non-value adding, but necessary	Any process that is carried out that does not increase the product's value from the customer's perspective, but still has to be performed as part of the production process.
Operating expense	All the money the system spends while turning inventory into throughput.
Operational measure	The measures throughput, inventory and operating expense, which according to theory of constraints, determine the organisation's bottom-line.
Process	A series of actions or steps taken in a particular order to achieve the desired effect.
Refractories	Ceramic materials used in high-temperature applications to withstand service at high temperature, abrasion, thermal shock and chemical attack.
Specification	An explicit requirement to be satisfied by the product or process.
Throughput	The rate at which the system generates money through sales.
Value stream map	A graphical representation of the value-adding and non-value-adding activities in any process.
Waste	A non-value-adding activity that is not necessary and can be eliminated.

# **1 Background and introduction**

## **1.1 Background**

Refractory materials are ceramic materials used in furnaces, boilers, smelters, and other high-temperature structures. They are ceramic products designed to withstand service at high temperatures and must also be resistant to chemical attack, abrasion and thermal shock (Du Toit & Berger, 2010:1).

In the case of refractory lining of furnaces, the refractory material is produced as a dry powder mix so that it can be mixed with water and applied to the surface of the furnace. For certain applications, the refractory material is also supplied as a mix pre-wetted with oil or tar. The production of these refractories is very similar to the dry batching plant used in the cement industry.

### **1.1.1 The organisation**

The organisation that was used as a case study wished to remain anonymous, as confidential financial information was included in this dissertation. Therefore, it will be referred to as “the organisation”.

The organisation is a small-to-medium enterprise that manufactures and installs refractory linings for a variety of industries, including the steel industry. It is a family owned and operated organisation, of which the owner and founder is still currently managing director and sole shareholder.

The organisation was founded in 2001, and since then has evolved into an organisation that is known for its ability to supply fully customised products on very short notice. The organisation boasts a vast collection of patented products, some that have no counterpart to be found elsewhere in South Africa.

According to the National Small Business Act (102/1996), the organisation is classified as a small-to-medium business in the manufacturing industry, as it employs 25 employees on average and has an annual turnover of less than R40 million.

The production plant operates on a single 8-hour shift per day on weekdays only and it produces an average of 420 tons per month.

### 1.1.2 The batching process

The process of measuring out the raw materials for a batch of concrete, or in this case, refractories, is called batching. The batching system at the organisation, although basic, is similar to the batching plants used in the concrete and construction industries internationally. Competitive manufacturers of refractory products also use it. A typical concrete batching plant can be seen in Figure 1.

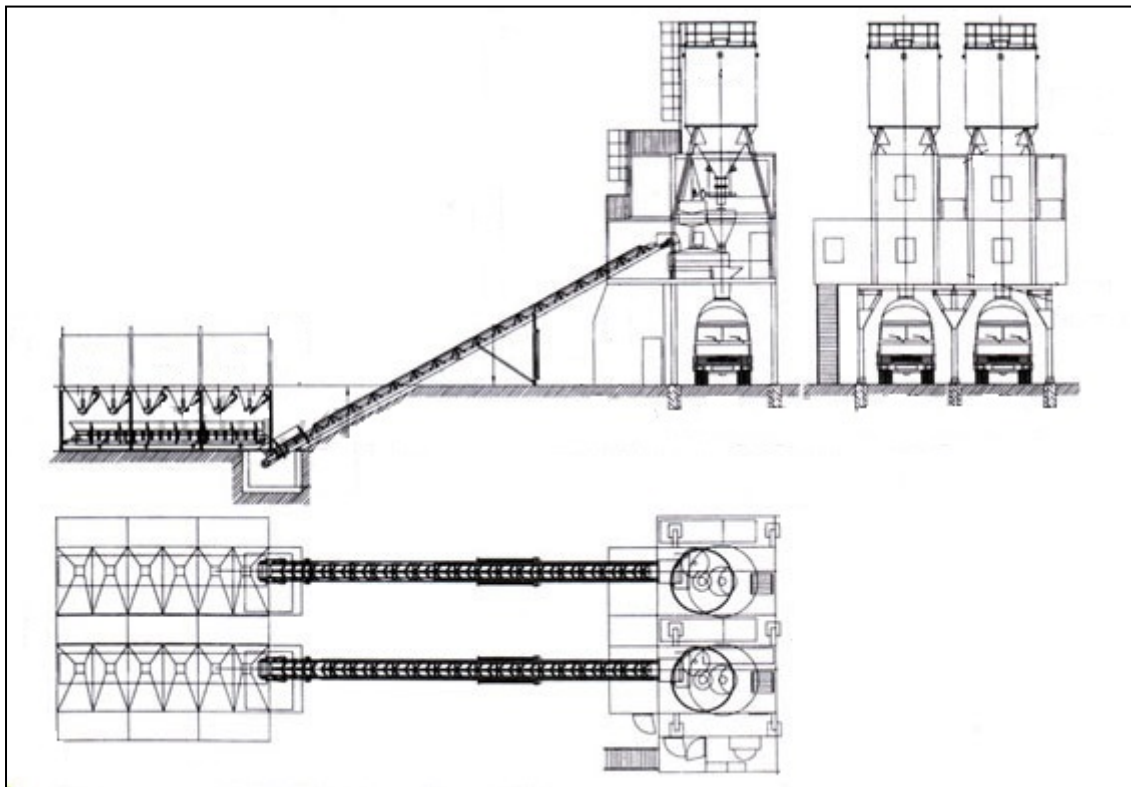
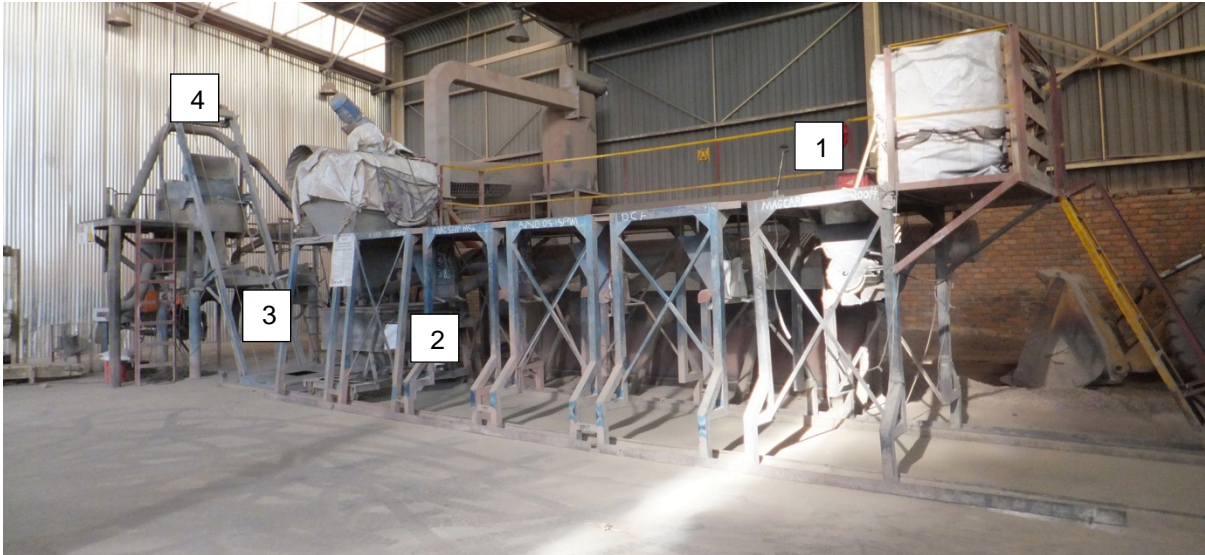

**Figure 1: A typical concrete batching plant (Gulin Crushers, 2010)**

The raw materials are discharged from the hoppers on the left onto a conveyor belt, which moves diagonally upwards to the mixer. The truck stops underneath the mixer to receive the concrete once it has been mixed, ready to be delivered.

### 1.1.3 The manufacturing process

The batching process at the organisation is very labour intensive, as it requires a labourer at every step of production. The organisation has two production lines, one of which can be seen in Figure 2.



**Figure 2: Production line at the organisation (Greeff, L., 2013a)**

All of the raw materials are supplied in bulk bags that contain 1 ton each, or in smaller bags, varying between 25 kg and 50 kg.

The sequence of the production process is illustrated in Figure 2 by the numbers as follows:

1. When manufacturing a product, the necessary raw material bulk bags are placed on top of the **production line** by a forklift. Below the bulk bags are hatch doors that open to allow the raw material to flow through like a hopper.
2. The correct amounts, according to the manufacturing plan, are discharged into the **trolley**, moving beneath the bags on a track. A labourer pushes the trolley underneath the hopper and production line and manually operates the hatch doors. A load cell on the trolley measures the weight of material dispensed.
3. Once the trolley has received all the materials required for the batch, it is pushed to a position over a **bucket** that is submerged in the floor at the end of the line. The labourer discharges the material from the trolley into this bucket.
4. The bucket is moved diagonally upwards, on machine-operated tracks, to the **mixer** at the top. The batch of material is mixed for the prescribed amount of

time. Each batch contains 500 kg of finished product. The mixer and bucket can also be seen in Figure 3.

5. After the batch has been mixed, it is bagged by a labourer operating an air pressurised hatch and funnel connected to the mixer. The final product bag is placed on a scale and is filled to the correct weight. Each bag must weigh 25 kg. The same labourer moves the bag along the **conveyor belt** through the **stitching machine**. The stitching station and conveyor belt can be seen in Figure 4. At the end of the conveyor belt, another labourer places the bag onto a pallet. One ton of finished product is packed on a pallet, meaning two batches of 500 kg. From there, the pallet is taken away with a forklift to the stretch-wrapping station.

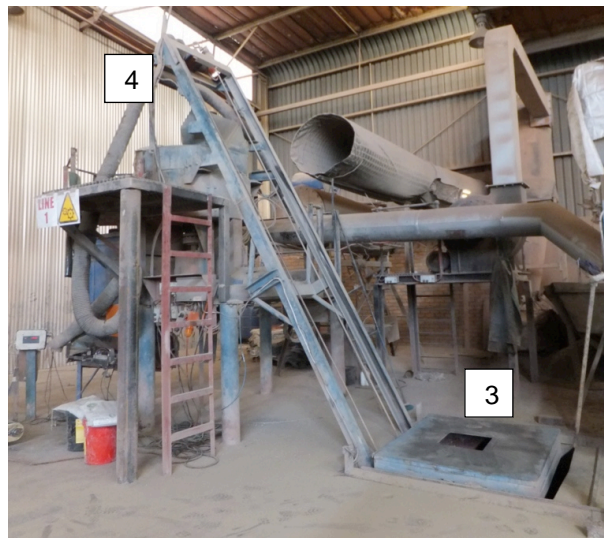

**Figure 3: The mixer on the production line (Greeff, L., 2013b)**



**Figure 4: The stitching station at the production line (Greeff, L., 2013c)**

#### **1.1.4 Quality control**

During production, quality control samples are taken. The first three batches, each consisting of 500 kg of product, are tested and after that, every fifth batch is tested throughout the batching process. For materials with a specified particle size, a sieve test is conducted at the production line. A second sample is sent to the laboratory to test the basic properties that are required for a test certificate to be issued, such as cold crushing strength (CCS) and bulk density (BD), as well as any other special characteristics the product may require, such as setting time, ram-ability, flow properties, etc. These are all product specific characteristics that determine the application and quality of the product. By adjusting the raw materials and their percentages within the dry mix, different products can be designed according to customer requirements.

#### **1.1.5 Premixing**

Most of the batches consist of large percentages of base raw materials, but there are a few formulations that require smaller quantities of ingredients, some as small as 0.02 % of the final mix. As it is difficult to distribute such a small quantity of material uniformly into the entire batch of 500 kg, a premix is made containing the small fraction(s) and typically 25 kg of one of the base raw materials that will form the largest part of the formulation. This premix is prepared by hand at a separate station, using an industrial cake mixer, and added to the bulk mixer before mixing the final product.

#### **1.1.6 Inventory management**

Production at the organisation is performed according to the just-in-time principle for the majority of its orders, as the products have an expiry date. There is a wide range of products with different applications and the customers can request adjustments to the chemistry to meet their specific needs. There are, however, a few general purpose products that are ordered by many customers and are kept in small quantities in inventory, as well as products for regular customer orders.

## **1.2 Introduction**

At the start of the study, the author was working at the organisation as project manager. During this time personal observations indicated that the production process was not functioning optimally. An example of this was an average of 144 tons of out-of-specification material was produced per year, which is 2.8% of the total production per year. Another example is production time lost on average was almost 700 hours per year due to waiting for raw materials to be delivered. The problem statement, proposed research and objectives, as well as the deliverables and the intended method of investigation, was developed to investigate and improve the specific situation at the organisation, and will be discussed in the following paragraphs.

### **1.2.1 The Lean Manufacturing philosophy**

According to Freedonia Group (2011), worldwide demand for refractories is projected to grow 5.3 % per year through 2014 to 40.8 billion tons.

The global steel industry has increased steadily since the global economic downturn in 2008; now steel producers face the new challenge of meeting a rise in demand for steel products (KPMG, 2011). This in turn, means that there is a rise in the demand for refractories, as it is an integral part in the production of steel.

As the price of iron ore, coal and energy have also increased, steel producers are struggling to maintain their profit margins, as the price for customers has not increased to the same degree. This has spilled over into all supplying industries, as well as the refractories industry. Companies that have reduced capacity and lowered their inventory levels during the global recession, starting in 2008, are now struggling to fill customer orders.

Due to the insufficient rise of customer prices in comparison to raw material prices, it is necessary to find ways to lower production costs to maintain the profit margin. In such a labour intensive environment as the semi-automated batching system, there is room for great improvement by means of production optimization.

For the conventional model of doing business, the equation for determining the price of the product is as follows:

$$\text{Cost} + \text{Profit} = \text{Price}$$

To obtain the desired profit, the price must be increased as the costs are fixed.

The Lean Manufacturing philosophy goes against looking at business from this point of view for at least two reasons:

- Price is a given, as the market demands a certain price for each product, and
- Manufacturers, like the organisation, have control over the cost of manufacturing.

The Lean Manufacturing philosophy uses the following equation:

Profit = Price – Cost.

Therefore, the only way to increase the profit would be to decrease the cost of the product (Pawlik, 2009).

### **1.2.2 Problem statement**

The production process at the organisation is not functioning optimally, as it suffers from unnecessary delays and produces non-conforming product, i.e. the product does not conform to the specifications required by the customer.

### **1.2.3 Research aims and objectives**

Therefore, the aim of this study was to determine how to increase the efficiency of the batch plant, as well as any other departments and management systems that contribute to production, which would decrease the cost of production per each ton of material. This will in turn increase the profit without raising the customer's price, as suggested by the Lean Manufacturing philosophy (Pawlik, 2009).

#### **1.2.3.1 Research objectives**

In order to address the problem stated in this study, the following objective had to be addressed, the relevant and most appropriate methodologies, or parts thereof, will be investigated to optimize production at the organisation and thereby increase profits. The research objectives are as follows:

- Research on different optimization methodologies.
- Identify investigative methodologies that can be used for the study.

- Identification of the best method or combination of different methods to best address the problem at the organisation.
- Create an optimization plan based on the results from the investigation.

#### **1.2.4 Deliverables**

The deliverables for this study were:

- A root cause investigation into the inefficiencies in the production system.
- An optimization plan, devised from the investigation, to be presented to the organisation as a production optimization solution, containing:
  - An estimation of the increase in production efficiency (throughput).
  - An estimation of the decrease in production cost (operating expenses and inventory).
  - An estimation of the total percentage increase in profit from decreasing the production cost.
- Recommendations for future study for continuous improvement within the organisation.

#### **1.2.5 Method of investigation**

A literature survey was conducted on the optimization methodologies available to improve production at the organisation, such as Lean Manufacturing and TOC.

An investigation of the current production process at the organisation was conducted to determine what the root causes for the problems were. The results from the investigation can be seen in Chapter 4 (Results from the investigation) and the appendices. The efficiency of the batch plant was determined by investigating the current production rate, which was determined by studying reports regarding production rate, total production averages, stock levels, etc. The financial statements were used to compare the operating expenses and the income generated from the sale of final product. These measures were then used as the benchmark to compare the estimated improvements that the optimization would provide.

Once the ideal optimization methodology and techniques were identified, the estimated improvement resulting from the optimization and the consequent increase in profit was compared to the current situation, to validate the effectiveness of the optimized production plan.

## 2 Literature survey

The problem that was identified was that the organisation was functioning non-optimally and consequently, losing production time due to waiting and unnecessary conveyance of product. Therefore, a literature survey was done on production optimization methodologies and techniques, including Lean Manufacturing and theory of constraints that could be applied to optimize production at the organisation.

### 2.1 Lean Manufacturing

Lean Manufacturing is based on the Toyota production system (TPS), which is the production system used by the Toyota automobile manufacturing plants. It is based on the philosophy that ideal conditions for manufacturing exist where there is no waste in machines, equipment or personnel (Japan Management Association, 1989:24).

The TPS is based on optimization methods such as, just-in-time, *kaizen*, one-piece flow, *jidoka* and *heijunka*. These techniques gave rise to Lean Manufacturing (Liker, 2004:6).

#### 2.1.1 The 14 principles of Lean Manufacturing

Lean Manufacturing is based on the following 14 business principles (Liker, 2004:37):

1. Base your management decisions on a long-term philosophy, even at the expense of short-term financial goals.
2. Create continuous process flow to bring problems to the surface.
3. Use “pull” systems to avoid overproduction.
4. Level out the workload (*heijunka*).
5. Build a culture of stopping to fix problems, to get quality right the first time.
6. Standardised tasks are the foundation for continuous improvement and employee empowerment.
7. Use visual control so no problems are hidden.
8. Use only reliable, thoroughly tested technology that serves your people and process.
9. Grow leaders who thoroughly understand the work, live the philosophy, and teach it to others.
10. Develop exceptional people and teams who follow your company’s philosophy.
11. Respect your extended network of partners and suppliers by challenging them and helping them improve.

12. Go and see for yourself to understand thoroughly the situation (*genchi genbutsu*).
13. Make decisions slowly by consensus, thoroughly considering all options; implement decisions rapidly.
14. Become a learning organisation through relentless reflection (*hansei*) and continuous improvement (*kaizen*).

These 14 principles will be discussed in more the detail below:

**2.1.1.1 Principle 1: Base your management decisions on a long-term philosophy, even at the expense of short-term financial goals.**

At Toyota there is a belief that there are certain ethical values that must be practised to remain profitable in the long-term. Some of these values are (Liker, 2004:72-83):

- That everyone has a sense of purpose greater than earning a salary. Employees must feel a great sense of mission for the company.
- That it is very important to do the right thing for the customer.
- That business decisions should not undermine trust and mutual respect.
- Using self-reliance and responsibility to decide your own fate.
- To follow the mission statement, consisting of three parts: contributing to the economic growth of the host country, contributing to the stability and wellbeing of the team members and contributing to the overall growth of Toyota.
- To create a constancy of purpose and place in history.

**2.1.1.2 Principle 2: Create continuous process flow to bring problems to the surface**

Flow is at the heart of a Lean Manufacturing organisation. By shortening the time needed to take raw materials to finished goods it will lead to the best quality, the lowest cost and the shortest time to deliver. By creating flow, the inefficiencies that require immediate solutions will become apparent (Liker, 2004:88).

An example of flow is when a customer places an order and the process of obtaining the raw materials needed for that specific order only, is triggered. These raw materials then flow immediately to the production process, where workers immediately assemble the order and it is then sent to the customer immediately (Liker, 2004:90).

Most companies use the traditional mass production thinking method, which is to organise the company into departments with similarly skilled people and machines grouped together,

forming a batching system. These departments are then measured by efficiencies. The problem is, however, that a lot of work-in-process inventory is accumulated by the most efficient departments. Another problem is that a specific order for a specific customer has to go through these different departments, causing delays (Liker, 2004:92).

According to Lean Manufacturing thinking, the ideal batch size is always one part or product. The fastest way to reduce batch sizes is to create work cells that are grouped by product, rather than by process, as departments are (Liker, 2004:93).

To create one-piece flow, *takt* time is used. *Takt* is a German word meaning “rhythm” or “meter”. *Takt* is the rate of customer demand, which is the rate at which the customer is buying product. *Takt* must be used to set the pace of production and is used to alert workers when they are getting ahead or behind (Liker, 2004:94).

### **2.1.1.3 Principle 3: Use “pull” systems to avoid overproduction**

An inventory “push” system is used in most cases. Products are pushed onto the retailer, irrespective of whether the retailer can sell it or not. The retailer then tries to push it onto you (the purchaser) whether you need it right away or not. The result of this is that inventory is not being used effectively (Liker, 2004:104).

The alternative is the “pull” system, wherein a customer orders the product and that triggers a signal to the supplier to send more of the product to the retailer. The retailer then receives the product on actual customer demand, thereby doing away with the excess inventory (Liker, 2004:105).

In Lean Manufacturing, the “pull” system involves the ideal state of just-in-time manufacturing; giving the customer what he wants, when he wants it and in the amount he wants it. But this will cause the company to have no inventory, and although it is considered as non-value-adding, a certain level of inventory is required as there are natural breaks in flow. The principle used by a supermarket can be implemented here, where patterns of previous purchasing is used to determine the exact amount of inventory required to form a replenishment system. Stores of materials are replenished based on the pull system (Liker, 2004:105).

#### 2.1.1.4 Principle 4: Level out the workload (heijunka)

It is not always possible to simply build-to-order, as the amount ordered can vary significantly. To accommodate this, Lean Manufacturing has developed a method for eliminating *muda*, *muri*, and *mura*. These three M's are described below (Liker, 2004:114):

- **Muri** – Overburdening of people or equipment: To push a person or machine beyond its natural limits, which results in safety and quality issues.
- **Mura** – Unevenness: This is caused by varying demand, which results in an irregular production schedule that is caused by downtime, missing parts or defects.
- **Muda** – Non-value-added: This includes the eight types of waste that will be described below.

##### 2.1.1.4.1 Elimination of waste

Lean Manufacturing requires that an organisation's non-value-adding activities, which are wasteful activities, must be determined. They are referred to as non-value-adding activities, as they are not adding any value to the product. A value stream map must be created to differentiate the value-adding activities from the wasteful or non-value-adding activities. An example of such a value stream map can be seen in Figure 5.

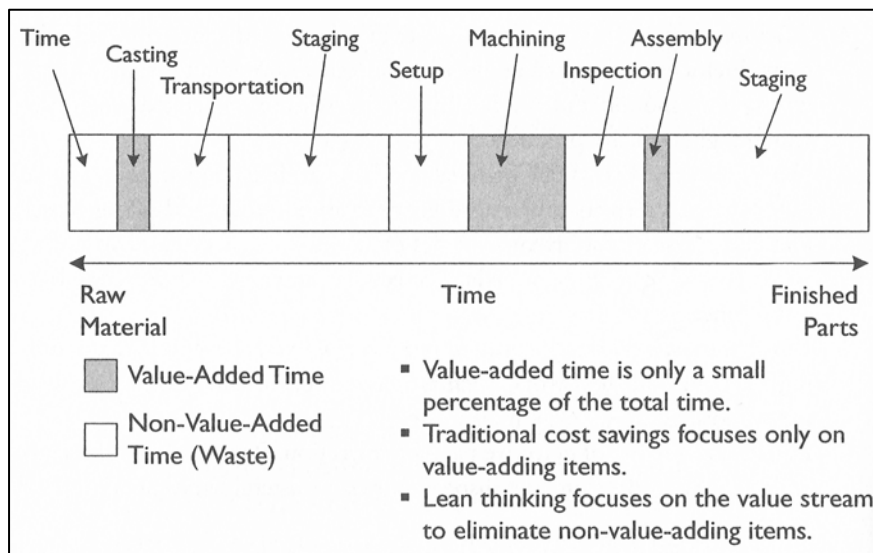

Figure 5: Value stream map for software development (Liker, 2004:30)

TPS has identified eight major types of non-value-adding activities, which are (Liker, 2004:28):

1. **Overproduction**, which leads to excess inventory.
2. **Waiting (time on hand)**, because of processing delays, downtime and capacity bottlenecks.
3. **Unnecessary transport or conveyance** of work in process (WIP) over long distances, or moving materials, parts or finished goods around.
4. **Over-processing or incorrect processing**, due to poor tool and product design, or unnecessary steps to process a part, providing higher quality products than required.
5. **Excess inventory**, including excess raw materials, WIP or finished goods, causing longer lead times, damaged goods, transportation and storage cost and delays.
6. **Unnecessary movement** of employees during the course of their work, such as looking for, reaching for, stacking of items and walking.
7. **Defects** that have to be repaired, reworked, scrapped, replaced and inspected leads to wasteful handling time and effort.
8. **Unused employee creativity** causes lost time, ideas, skills, improvements and learning opportunities by not listening to the employees.

In order to reduce waste, the concept of *heijunka*, levelling out the work schedule, is applied. *Heijunka* is the levelling of production by both volume and product mix. In so doing, the company does not produce product according to the flow of customer orders, but rather according to the total volume of orders in a period of time, and levels it out, so that the same amount and product mix are being made each day. This is done by taking the actual customer demand, determining a pattern of volume, and mixing and building a level schedule every day (Liker, 2004:116).

The difference between the traditional approach of production according to orders and levelled production can be seen in Figure 6.

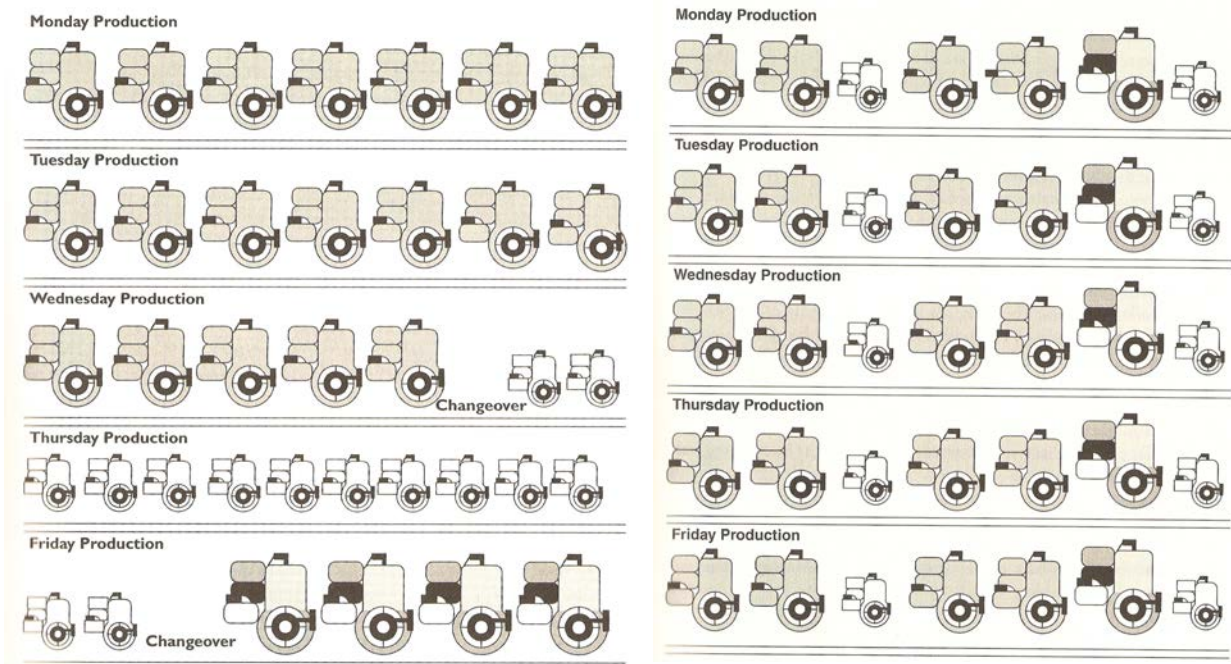

**Figure 6: Traditional production on the left vs. levelled production on the right (Liker, 2004:117-119)**

### **2.1.1.5 Principle 5: Build a culture of stopping to fix problems, to get quality right the first time**

The principle of *jidoka* originated from an automated loom with a built-in device for making judgments. As the loom stopped when a problem occurred, no defective products were produced. This meant that numerous machines could be supervised by one operator, and resulted in a remarkable improvement in productivity (Toyota, 2011).

As there is meant to be as little as possible inventory with Lean Manufacturing, it is very important to produce products correctly the first time. A signalling system, called *Andon*, was developed wherein a signal, such as a light, indicates when equipment shuts down and an operator is needed to solve a quality problem. Only the one workstation was stopped; not the entire production line. The team leader has to respond to the light and has time until the part moves to the next station to fix the problem. If this is not possible, then the entire line will stop (Liker, 2004:130).

### **2.1.1.6 Principle 6: Standardised tasks are the foundation for continuous improvement and employee empowerment**

Lean Manufacturing requires that tasks are Standardised throughout the entire company, including white-collar work processes. According to this principle, it is impossible to improve any process without standardising it. A process must be standardised, and thereby stabilised, before continuous improvement can take place. It is also very important to ensure quality. If a standardised work procedure was followed, it is much easier to determine where the defect originated from (Liker, 2004:142).

When implementing standardisation to meet challenging targets consistently, it is critical to find a balance between providing employees with rigid procedures to follow and providing the freedom to innovate and be creative. What is important when trying to achieve this is that the standards have to be specific enough to be useful guidelines, but general enough to allow for some flexibility. The employees performing the work then have to improve the standard (Liker, 2004:147).

### **2.1.1.7 Principle 7: Use visual control so no problems are hidden**

In the TPS, there are visual controls for eliminating waste that contribute to errors, defects and injuries. One of these visual controls is the 5S-program and it comprises of the following five S's (Liker, 2004:150):

1. **Sort** – Keep only what is needed and dispose with what is not.
2. **Straighten** – Create order by putting everything in its place.
3. **Shine** – The cleaning process acts as a form of inspection that exposes pre-failure conditions.
4. **Standardise** – Develop systems and procedures to maintain and monitor the first three S's.
5. **Sustain** – It is an on-going process of continuous improvement to maintain the stabilised workplace.

Visual control entails being able to look at the process, a piece of equipment, inventory, and information, or at a worker performing a task and immediately seeing the standard being used and any deviation from that standard (Liker, 2004:152).

**2.1.1.8 Principle 8: Use only reliable, thoroughly tested technology that serves your people and processes**

Once again, the TPS philosophy for technology is that it should add value. The technology must serve the process and people, and not replace the people. It is often best to perform a process manually, rather than adding untested technology that may end up not being useful to the process.

Toyota looks at technology as a tool to support both the people and the process. The process must first be made to work flawlessly by means of manual labour before it can be automated. This ensures that technological errors do not cloud the efficiency of the process and cause confusion as to what the real problems are. Technology can also constrict flexibility in the production process, making changeovers in production items difficult and time-consuming. It is, of course, not always necessary to automate every production process. This principle is an ideal approach for a small or start-up business, which does not have the capital available to automate every process (Liker, 2004:159-168).

**2.1.1.9 Principle 9: Grow leaders who thoroughly understand the work, live the philosophy, and teach it to others**

Lean Manufacturing focuses on growing your own leaders from within your company, rather than buying them from outside the organisation. This is based on the concept of eliminating *muri* (unevenness), as discussed in Principle 4 (Paragraph 2.1.1.4). It is important to ensure that your philosophy remains constant, and to only change your philosophy to adapt as the company and the people within it grows. The philosophy greatly depends upon the leader of the organisation; the leader must promote the culture amongst the workers every day.

Another aspect is to understand what the customer wants. One way that TPS achieves this is by selling door-to-door. This creates a personal bond between the company and the customer, and it gives an idea of what the company and its products mean to the customer (Liker, 2004:169-183).

**2.1.1.10 Principle 10: Develop exceptional people and teams who follow your company's philosophy**

Lean Manufacturing focuses strongly on teamwork. All the systems are there to support the team that are doing the value-adding work. But, although the teams co-ordinate their work, motivate each other, suggest innovative ideas and even control peer pressure, they do not actually perform the work. The individuals perform the work. As such, the individuals are the most familiar with the problems that affect them and they are, therefore, at the top of the hierarchy of the team structure. The rest of the hierarchy is there to support them (Liker, 2004:184-198).

**2.1.1.11 Principle 11: Respect your extended network of partners and suppliers by challenging them and helping them to improve**

TPS views new suppliers cautiously and only places very small orders at first, until the new supplier has proven their sincerity and commitment to Toyota's high standards for quality, cost and delivery. Lean Manufacturing's need for continual improvement does not only apply to its own people, but also to its network of suppliers and partners (Liker, 2004:199-220).

**2.1.1.12 Principle 12: Go and see for yourself to thoroughly understand the situation (genchi genbutsu)**

This principle of Lean Manufacturing is based on grasping the actual situation, which can only be fully understood by going to see for yourself, even if you are part of top-management. Using data alone cannot identify the actual problem, as data is already one-step removed from the process. However, more than just a superficial knowledge of the process is required; it must be a deep understanding, which takes many years for employees to master. In addition, these same employees must be able to identify the root cause of the problem (Liker, 2004:223-236).

**2.1.1.13 Principle 13: Make decisions slowly, by consensus, thoroughly considering all options, and implement those decisions rapidly**

Lean Manufacturing leaves nothing to be assumed, everything must be verified. They believe that how you arrived at the decision is just as important as the quality of the decision. Five major elements have to be considered:

1. Finding out what is really taking place.
2. Understanding the underlying circumstances by asking “why” five times. An application of the 5-Why analysis can be seen in Figure 7.
3. Broadly considering alternative solutions, then developing a detailed foundation for the preferred solution.
4. Building consensus within the team.
5. Using efficient communication to complete steps 1 to 4.



Level of Problem	Corresponding Level of Countermeasure
There is a puddle of oil on the shop floor	Clean up the oil
Because the machine is leaking oil	Fix the machine
Because the gasket has deteriorated	Replace the gasket
Because we bought gaskets made of inferior material	Change gasket specifications
Because we got a good deal (price) on those gaskets	Change purchasing policies
Because the purchasing agent gets evaluated on short-term cost savings	Change the evaluation policy for purchasing agents

**Figure 7: The 5-Why analysis (Liker, 2004:253)**

A very important factor in Lean Manufacturing is set-based concurrent engineering, whereby more than one alternative solution to a problem is considered in terms of the design and manufacturing system. The term *nemawashi* describes the process of junior personnel building a consensus by developing a proposal and circulating it broadly before management approval. By doing this, many people are asked for their input, and it creates a consensus before management implements the proposal. However, when a consensus

cannot be reached before the alternatives have to be presented to management, then management has the final say in which alternative will be implemented.

By going through the lengthy process of reaching a consensus, all the facts are gathered before it is too late; it gets everybody on-board and creates support for the solution before the planning stage commences (Liker, 2004:237-249).

**2.1.1.14 Principle 14: Become a learning organisation through relentless reflection (*hansei*) and continuous improvement (*kaizen*)**

Once a stable process has been established, continuous improvement tools must be employed to determine the root cause of inefficiencies so that they may be addressed. When new processes are designed, it should allow for as little as possible inventory. The best practises should be standardised to improve problematic procedures, rather than taking a different direction whenever inefficiency is discovered (Liker, 2004:40-41).

## 2.2 The theory of constraints (TOC)

The theory of constraints states that performance of a process is determined by its constraints, meaning that a process is only as effective as its slowest or weakest link (Blackstone, 2010).

### 2.2.1 The goal

According to Goldratt and Cox (2004), the goal of any organisation is to make money. There are three measurements, called the global operational measurements, which are used to determine whether an organisation is reaching its goal. These measurements are defined as follows (Goldratt & Cox, 2004:40):

- **Throughput** – the rate at which the system generates money through sales.
- **Inventory** – the money the system invests in purchasing items that the system intends to sell.
- **Operating expenses** – all the money the system spends while turning inventory into throughput.

**These measures can be linked to the bottom-line as shown below in**

Table 1:

**Table 1: The effects of global operational measures on the bottom-line (Goldratt & Fox, 1986:31)**

Increase or Decrease		Net profit	Return on investment	Cash flow
Throughput	↑	↑	↑	↑
Inventory	↓		↑	↑
Operating expense	↓	↑	↑	↑

## **2.2.2 The definition of a constraint**

A constraint can be anything that prevents the system from achieving a higher performance rate in comparison to its goal. A system is a collection of any parts or processes that work together to achieve a common goal. There are different types of constraints, including the following (Blackstone, 2010):

- Resource constraints, such as people or departments that cannot keep up with demand.
- Policy constraints, which are management-related decisions or business cultures, such as working hours.
- Dummy constraints, which are constraints that can easily be rectified. An example of this would be to call out maintenance staff during afterhours, even though it is more expensive to do so, because the extra expense does not outweigh the cost of production lost due to waiting for maintenance during the afterhours shift.

Any system, no matter how well it performs, always has at least one constraint. As this constraint is described as the weakest link in the system, there can always be just the one constraint. The other weaknesses remain non-constraints until they become the weakest link in the system (Goldratt & Cox, 2004).

## **2.2.3 The five focusing steps**

Goldratt listed five steps for managing constraints that will be discussed below (Goldratt & Cox, 2004:335). According to Blackstone (2010), adding two additional steps to the beginning of the process, will make Goldratt's process of managing constraints more complete. These two steps are:

1. Decide what the goal of the system is.
2. Determine what the system's performance measures are.

Goldratt's five steps are the following (Goldratt & Cox, 2004:335):

### **2.2.3.1 *Identify the system's constraint(s)***

The part of the system that is its weakest link must be identified, and the type of constraint determined.

### **2.2.3.2 *Decide how to exploit the system's constraint***

The constraint can be exploited by utilising the constraining component fully, without having to make expensive changes or upgrades.

### **2.2.3.3 *Subordinate everything else to the decision taken in step 2***

After the best method of exploiting the constraint has been determined, the rest of the system must be adjusted to enable the constraint to operate at its maximum capacity. The result must be evaluated to determine if the constraint is still holding the system back. If so, Step 4 should follow, if not, the constraint has been eliminated and Step 5 should follow.

### **2.2.3.4 *Elevate the system's constraint(s)***

Elevating the constraint implies that whatever action is necessary to eliminate the constraint, should be taken. This can involve major and costly changes to the system.

### **2.2.3.5 *If in a previous step, the constraint was lifted, go back to step 1. Do not let inertia cause a system constraint***

Once the constraint has been lifted, the steps must be repeated again, to look for the next constraint. The impact made by the changes required for the subsequently identified constraints on the already improved constraints, must be monitored throughout the process of improvement.

## 2.3 Time and motion study

In order to apply the optimization methodologies such as Lean Manufacturing and TOC, investigative tools are required to gain data from the production process at the organisation.

According to Groover (quoted by Wicaksana, 2013), motion studies are performed to eliminate waste. The process to be studied must be divided into process activities classes. There are five of these classes:

- Operations – Causes a change in the properties of the product.
- Transportation – The location of the product changes.
- Inspections – Confirmation that any changes are within specification.
- Delays – Time spent waiting for the start of an operation, transportation or inspection.
- Storage – Wait until the product is required by a next step.

After the process has been divided into activity classes, a time study can be conducted as follows (Subasinghe, 2009):

1. Define and document the standard method.
2. Divide the task into work elements.
3. Time each work element.
4. Evaluate the worker's pace against the standard performance rating, to determine the normal time.
5. Apply an allowance to the normal time to compute the standard time.

### 2.3.1 Normal time

The normal time (Nt) can be calculated by using the following equation:

$$Nt = (\text{elemental average time}) \times (\text{Rating factor})$$

### 2.3.2 Standard time

The standard time can be calculated using the following equation:

$$\text{Standard time} = (\text{Observed time}) \times (\text{rating factor}) + (1 + \text{Personal, Fatigue and Delay allowances for the worker})$$

### 2.3.3 Rating factor

The rating factor will be determined using the Westinghouse standard, which can be seen below in Figure 8. The task is assessed according to the skill, effort, environment and consistency it takes to complete it and the rating factor is added or subtracted as a percentage on top of the normal time, by adding the total score to 1 to determine the rating factor.

Skill ratings			Environmental condition Ratings		
+0.15	A1	Superskill	+0.06	A	Ideal
+0.13	A2	Superskill	+0.04	B	Excellent
+0.11	B1	Excellent	+0.02	C	Good
+0.08	B2	Excellent	0.00	D	Average
+0.06	C1	Good	-0.03	E	Fair
+0.03	C2	Good	-0.07	F	Poor
0.00	D	Average	Consistency ratings		
-0.05	E1	Fair	+0.04	A	Perfect
-0.10	E2	Fair	+0.03	B	Excellent
-0.16	F1	Poor	+0.01	C	Good
-0.22	F2	Poor	0.00	D	Average
Effort ratings			-0.02	E	Fair
+0.13	A1	Excessive	-0.04	F	Poor
+0.12	A2	Excessive			
+0.10	B1	Excellent			
+0.08	B2	Excellent			
+0.05	C1	Good			
+0.02	C2	Good			
0.00	D	Average			
-0.04	E1	Fair			
-0.08	E2	Fair			
-0.12	F1	Poor			
-0.17	F2	Poor			

Figure 8: The Westinghouse rating system (Cevikcan et al, 2012)

### 2.3.4 Allowances

Allowances are made to compensate unavoidable delays that are bound to happen due to variations in the process as well as the worker, which could not all have happened during the time that the time study was executed. These are personal, fatigue and delay allowances.

**Personal** allowances for the worker's physical needs like taking breaks. According to the Indian institute of technology, Delhi (IITD), 5% is considered appropriate.

**Fatigue** allowances are due to the physical nature of the task at hand. According to IITD, 4% of normal time is considered appropriate under normal conditions for light work while seated. For more vigorous work, it will have to be increased.

**Delay** allowances are for the numerous interruptions a worker will experience during the day like material interruptions, fellow workers, difficulty maintaining specifications and tolerances. According to IITD, 4% of the normal time is an appropriate value for to allow for this.

### 2.3.5 Flow process chart

A flow process chart can also be used to determine the time and distance travelled that was lost due to wasteful activities. According to ASME Standard Operations and Flow Process Charts (1947), a flow process chart is a graphic representation of the sequence of all operations transportations, inspections, delays and storages occurring during a process or procedure, including information considered desirable for analysis, such as time required and distance moved. An example of a flow process chart can be seen in Figure 9.

### FLOW PROCESS CHART

SUBJECT CHARTED <u>RELIEF VALVE BODY</u>						CHART NO. <u>1021</u>	
DRAWING NO. <u>A-520612</u>			PART NO. <u>16150</u>		CHART TYPE _____		
CHART BEGINS <u>Barstock Storage</u>				CHARTED BY <u>J. Smith</u>			
CHART ENDS <u>Assembly Department Storeroom</u>				DATE <u>9-9-43</u>			
○	OPERATION		➡	TRANSPORTATION		SHEET NO. <u>1</u> OF <u>1</u> SHEETS	
□	INSPECTION		D	DELAY		COST UNIT <u>1 Valve Body</u>	
					▽	STORAGE	
DIST. MOVED FT.	UNIT OPER. TIME Hr.	UNIT TRANSP. TIME Hr.	UNIT INSPEC. TIME Hr.	DELAY TIME Hr.	STORAGE TIME Hr.	CHART SYM-BOLS	PROCESS DESCRIPTION OF <i>Proposed</i> METHOD
						▽	Stored in bar stock storage until requisitioned
10	.0002					①	Bars loaded on truck upon receipt of requisition from machine shop (2 men)
210		.0002				①	Moved to #301 machine
10	.0002					②	Bars unloaded to bar stock rack near #301 machine
				4.00		①	Delayed awaiting for operation to begin
8	.0550					③	Drill, bore, tap, seat, file, cut off
				2.00		②	Delayed awaiting drill press operator
20		.00002				②	Moved to drill press by operator
8	.0350					④	Drill 8 holes
				2.00		③	Delayed awaiting moveman
300		.0011				③	Moved to burring department
				1.50		④	Delayed awaiting burring operation
6	.0100					⑤	Burr
				2.00		⑤	Delayed awaiting moveman
550		.0005				④	Moved to seat lapping machine in detail department
				6.00		⑥	Delayed awaiting operator
6	.1700					⑥	Lap seat, test, and inspect
				2.00		⑦	Delayed awaiting moveman
400		.0004				⑤	Moved to paint booth
				6.00		⑧	Delayed awaiting painter
15	.0380					⑦	Mask, prime, paint, dry, unmask, and pack in box
425						⑥	Sent by conveyor to assembly department storeroom
					60.0	▽	Stored until requisitioned

Figure 9: Example of a flow process chart (The American Society of Mechanical Engineers, 1947:15)

### 2.3.6 Process flow diagram

According to ISO 5807:1985, a flowchart is defined as the graphical representation of the definition, analysis or problem solving method, using symbols to represent operations, data, flow, equipment, etc. (International Organisation of Standardisation, 1985). Special symbols are used to represent the stages of the process. An example of a process flow chart for computer program can be seen in Figure 10.

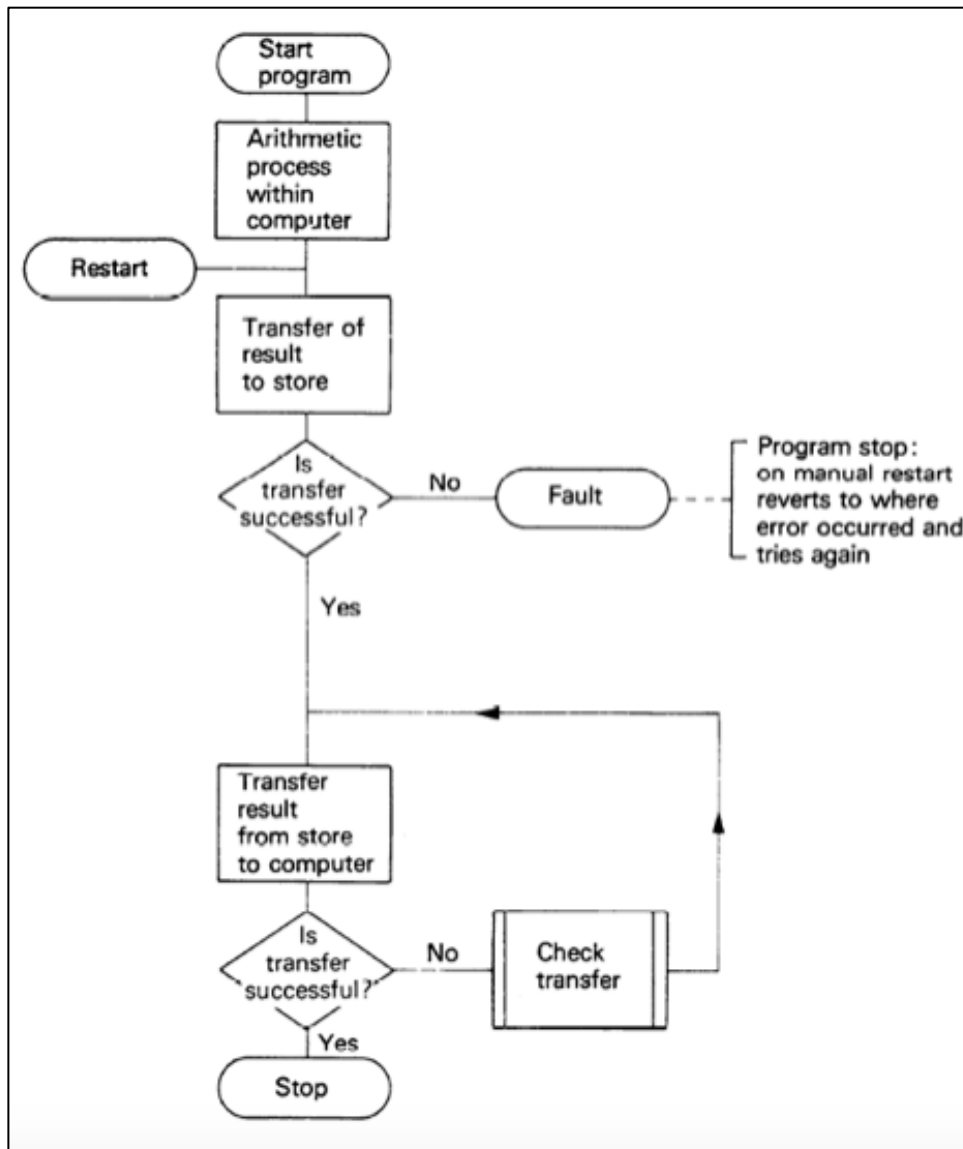

Figure 10: Example of a process flowchart (The International Organisation of Standardisation, 1985))

According to Pigage and Tucker (1954), a process flow diagram can be created from the process flowchart combining the symbols of the process flowchart onto a floor layout. An example of how the flow process chart's symbols in Figure 11 can be combined with the process flow diagram in Figure 12 can be seen below.

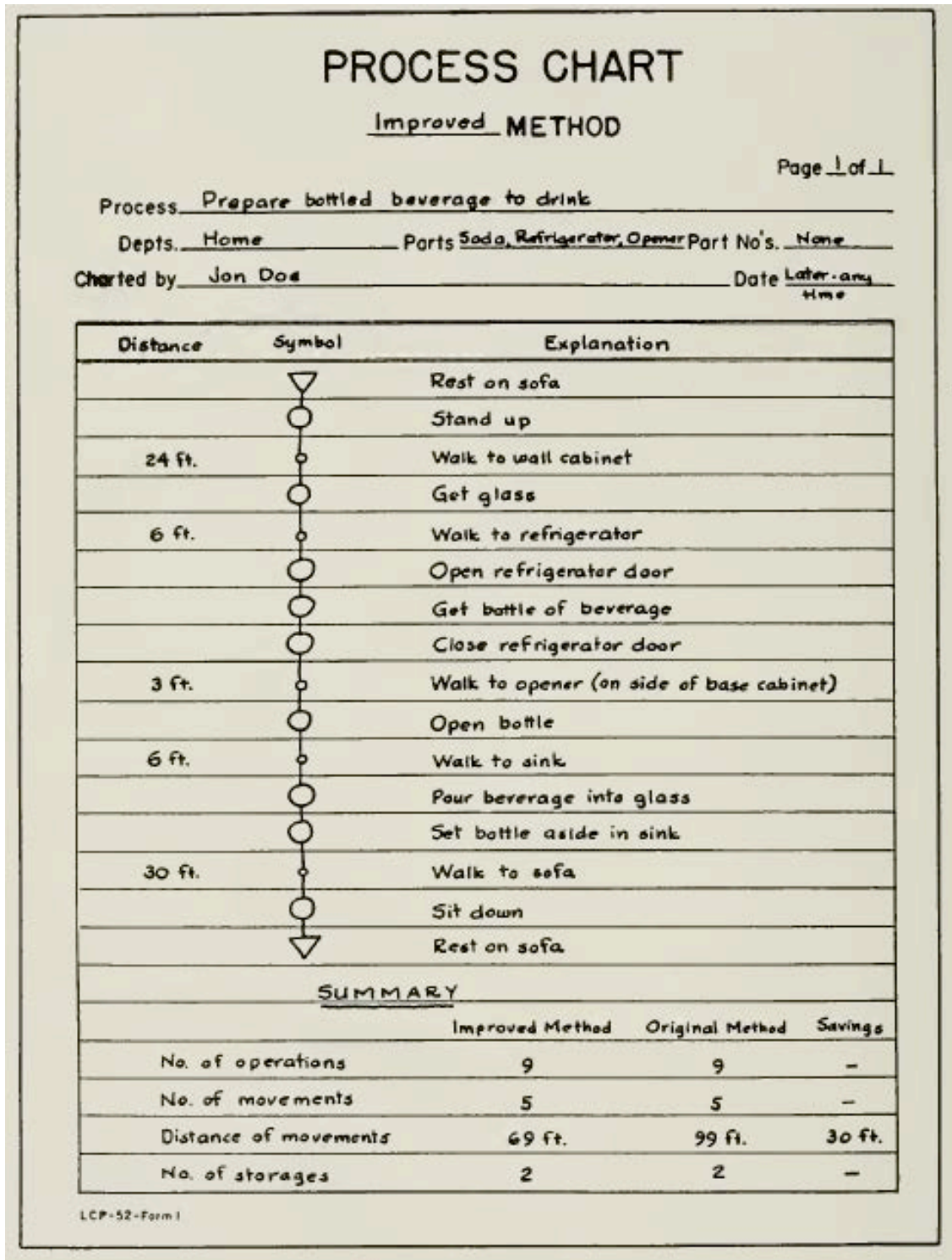

Figure 11: Example of a process flow chart (Pigage & Ticker, 1954:16)

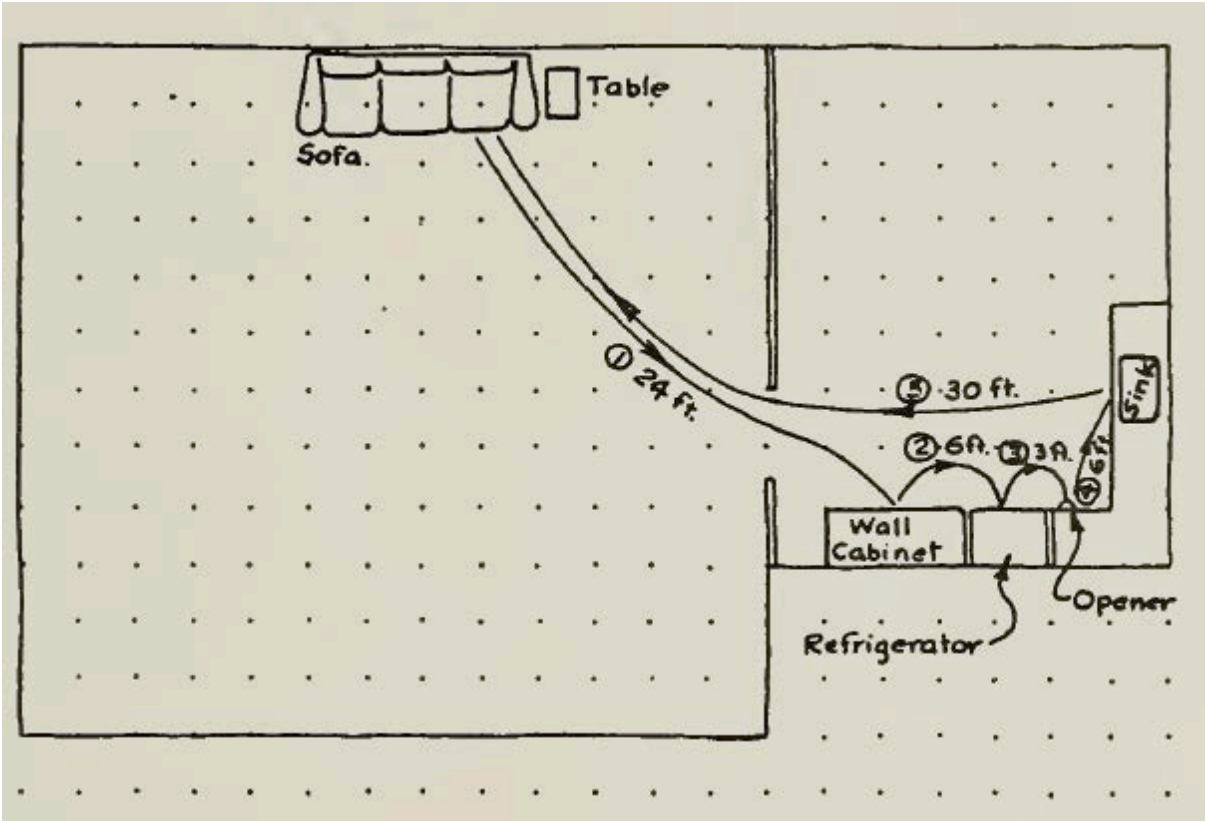

Figure 12: Example of a process flow diagram (Pigage & Ticker, 1954:17)

## **2.4 Critical review of production optimization theory applicable to the case study organisation**

Lean Manufacturing and TOC are traditionally applied to large multinational manufacturing organisations.

One of the challenges of this study is to apply these methods to a case study organisation with only 25 employees. Therefore, the researcher had to distil the fundamentals of these strategies so that it could be applied at the organisation. The methodologies will not be applied exactly as they are.

The basic philosophy of Lean Manufacturing is that ideal condition exists where no waste exists and it is based on 14 management principles. Many of these principles are meant for large organisations, like in the case of Toyota, they help to develop their philosophy in the network of suppliers. As the case study organisation is small and not all of these principles are directly applicable, the basic philosophy will be focussed on, which is to strive to create the ideal condition where no waste exists. A value stream map will be used to identify the wasteful activities.

During the preliminary observations into the necessity of this investigation, it was found that production time was lost because the process had to wait for raw materials to be delivered and the workstations were placed far apart causing excessive motion of the product. Therefore, it was decided that together with Lean Manufacturing principles a time and motion study must be conducted to help identify where the waiting times was the biggest concern as well as where unnecessary motion was originating from. The need for a flow process chart and flow diagram was also realised in order to visualise the flow. As suggested by Lean Manufacturing principles, a 5-Why analysis will be used to determine the root causes of the problems, so that possible solutions can be identified.

TOC states that the performance of a process is determined by its constraint. The first step of TOC is to identify the constraint. As the causes for the problems at the organisation can already been identified by means of Lean Manufacturing principles and a 5-why analysis, the operational measures of TOC will rather be used to determine the benchmark for the optimization plan. These measures - throughput, inventory and operating expense can be used to determine if the proposed optimization plan will increase the profit in the organisation, which is the goal according to TOC.

### **3 Investigational procedure**

From the knowledge gained in the literature survey on optimization methodologies an investigation into current practices at the organisation was launched to determine the root causes of the problems that were causing the production plant to function non-optimally.

The wasteful activities will be identified and eliminated, using a value stream map, according to the principle 4 from Lean Manufacturing (Levelling out the workload).

The goal of any organisation, according to TOC, is to make money. The operational measurements, which determine if this goal is reached, are throughput, inventory and operating expense. These measures will be used as a benchmark to determine if the proposed optimization plan will help the organisation to increase its ability to make money, and obtain its goal.

An investigation will be launched to find the wasteful activities and to determine the effect the wasteful activities has, as well as their proposed solutions will have on the operational measurements. From this, the wasteful activities will be identified and a value stream map can be created to determine which activities are wasteful, and which are wasteful but necessary.

The methodology for the investigation as given below:

#### **3.1 A flow process chart**

This will be used to visualise the flow of the process. A time and motion study will be conducted to determine the time and distance travelled during the production process, as discussed in paragraph 2.3 (Time and motion study).

#### **3.2 A value stream map**

A value stream map will be created to identify the wasteful activities in the production process as described by Lean Manufacturing – Paragraph 2.1.1.4, using the flow process chart and the time and motion study.

### **3.3 A process flow diagram**

A process flow diagram, depicting the floor layout of the production process, will be created to understand better where the motion of the product is causing wasteful activities, as described in paragraph 2.3.6.

### **3.4 A 5-Why analysis to determine the root causes**

Once the wasteful activities have been identified, a 5-Why analysis will be conducted to determine the root cause of the problems causing the wasteful activities, based on Lean Manufacturing (paragraph 2.1.1.13).

### **3.5 The operational measures based on TOC**

The operational measures described by TOC are throughput, inventory and operating expense. At the organisation, they were the following:

1. Throughput – Production rate, obtained from the production reports.
2. Inventory of raw material and finished product – Stock take and cost of raw materials.
3. Operating expense – Production and raw material expenses.

These operational measures were determined by various reports from the production and financial departments and were used as a comparison tool to verify the estimated improvements that would be achieved with the implementation of the optimization plan.

#### **3.5.1 Throughput**

The production reports in Appendix C: Total production and operating hours, were used to determine the following:

- The production rate.
- The average annual operating hours.
- The average annual production of final material.

### **3.5.2 Inventory**

To determine the effect on the inventory, the following expenses were used:

- The annual combined expense of raw materials and packaging materials for production and stock-levels (Table 10, Inventory).
- The additional packaging expense, due to rework of out-of-specification product.
- The once-off cost of raising the raw material levels to the minimum buffer for stock levels (Table 13, Prioritisation and buffer levels of raw materials at the ).

These figures were used to determine what effect the acquisition of more raw materials would have on the bottom-line. As the raw materials were ordered for when orders were placed, the majority of the expense on inventory was for the purpose of production, and not for inventory to maintain stock-levels. There were, however, a few items for which a buffer was kept, so the expense on inventory for production and inventory for stock were combined.

### **3.5.3 Operating expenses**

In order to obtain insight into the productivity of the batch process, the production reports for the previous four years, 2009 to 2012, were summarised (Appendix C: Total production and operating hours). The production plant was relocated to a different building at the end of 2008, therefore, only the data obtained from 2009 onwards could be used to gain insight into the operating expenses of the process.

The cost of production and quality control was determined by investigating the expenses of the production plant. The following expenses were taken into account:

- The average cost per operating hour.
- The average operating cost per year.

These expenses were used to determine what effect the optimization plan would have on the operating expense.

### 3.6 Summary

The investigative methodologies were used to obtain the results as presented in Chapter 4 (Results from the investigation) and the operational measures were used as part of the optimization plan in Chapter 5 to determine what effect the optimization plan would have. A summary can be seen in Table 2.

In order to determine if the proposed optimization plan would have a positive effect, the operational measures as described by TOC will be used as benchmark measurements. The investigative methodologies will be used in combination with the operational measures from TOC to visualise the process, identify wasteful activities, increase the production flow and identify the root causes of the problems.

**Table 2: Tools and measures used during the investigation**

	<b>Investigative method or operational measure</b>	<b>Reason</b>
<b>3.1</b>	<b>Investigative method</b>	
3.1.1	Flow process chart	Visualise the process clearly
3.1.2	Value stream mapping	Identify wasteful activities
3.1.3	Process flow diagram	Create better flow
3.1.4	5-Why analysis	Identify the root causes of problems
<b>3.2</b>	<b>Operational measure</b>	
3.2.1	Throughput	To determine the effect of the optimization plan on throughput
3.2.2	Inventory of raw materials and finished product	To determine the effect of the optimization plan on inventory
3.2.3	Operating expense	To determine the effect of the optimization plan on operating expense

## **4 Results from the investigation**

After completion of the investigation plan, as outlined in Chapter 3, the results gained from using the investigative methodologies are given below according to their corresponding paragraph numbers:

4.1 A flow process chart was created.

4.2 A value stream map was drawn up.

4.3 Process flow diagram was drawn up.

4.4 The root causes were determined by means of the 5–Why analysis.

The results were used to create the optimization plan for the organisation. The operational measures from TOC were used as a benchmark for the estimated improvement gained from the optimization plan.

### **4.1 Flow process chart**

The first step after receiving a request from the client was to determine what the correct product would be for the specific application. If no such product had been formulated before, then a new product would be designed, or an existing product would be redesigned to fit the specific purpose.

The process for the initial design of a product followed the following path: the laboratory produced small-scale samples to test the characteristics of the test product. When a formulation was found that complied with the customer requirements, the test sample and its results were used for quotation purposes. However, due to poor recordkeeping by the laboratory, or incomplete sample testing, the test results or the formulation design were often misplaced following the quoting phase.

Once the correct product was selected and the estimated tonnage calculated (using the drawings provided by the client), a quotation was given to the client. If no drawings of the relevant surface for application were provided, then a quotation was given per ton.

After receipt of a purchase order for a newly designed product, the laboratory sampling and tests performed initially often needed to be redone, due to the stated recordkeeping deficiencies, to determine the exact composition of the product as quoted, and to ensure that the product would conform to the specifications of the quoted product. This period also

allowed for the opportunity to improve upon the product specifications and to up-scale the test sample batch.

Once the order was received, the relevant raw materials were ordered, as there is often not enough stock due to poor stock management.























After receipt of the raw materials, the raw materials were screen tested by the laboratory to ensure that the particle sizes of each product were within specification. Once the raw materials had been approved, production could commence. The production line was cleaned and the raw materials transferred from the store area to the production line.

Premixing was started before bulk production commenced, as a premix must be mixed for a longer time to achieve a uniform mixture. Production then continued alongside the premixing station.

Quality control samples were taken from the bulk mixer once mixing was completed, to ascertain that the up-scaled batch comprised of the same specifications as that of the small-scale laboratory test samples. If the samples indicated that certain specifications were nearing their established control limits, adjustments could be made during production to avoid the production of out-of-specification product. This step also allowed for the issue of a proof of quality conformance certificate to the customer. If the material was found to be out-of-specification, either during or after production, then the product had to be reworked and retested. This caused delays and additional production costs, but ensured customer satisfaction.

The finished product was bagged, stitched, and packed onto pallets and moved with forklifts to the wrapping station. After stretch wrapping the order, it was moved to the final product bay with a forklift, from where it would be dispatched.

The flow process chart can be seen below in Figure 13. The time elapsed and the distance travelled were determined by conducting a time and motion study, as discussed in paragraph 2.3 (Time and motion study) and can be found in Appendix A: Time and motion study.

Distance travelled	Time elapsed	Symbol	Process description
			Receive order
	37.14 min		Ensure that the manufacturing plan is correct
	10.87 hours		Test the manufacturing plan in the lab
	82.76 min		Inspect the raw material levels
	2.27 days		Wait for ordered materials
	33.81 min / ton		Receive and screen raw material
26.23 m			Move accepted raw materials into store
			Store material until requisitioned
	27.07 min		Clean the production line
128.71 m			Move material from the store to the production line
	26.10 min		Load the production line
	5.70 min		Check the material against the manufacturing plan
	2.95 min		Inspect the calibration of the scales
	36.51 min		Calibrate the scales
	11.61 min / ton		Premixing and batching of materials into the trolley
	12.09 min / ton		Mixing of the materials
	8.05 min / ton		Bag the material and stich the bags
	13.28 min / batch		Test the quality control samples of every fifth batch
	13.67 min / batch		Wait for approval of quality control samples
35.79 m			Move the product to the wrapping station
	12.63 min / ton		Wrap the pallets of finished product
32.59 m			Move the material to the finished product bay
			Store the finished product until dispatch

**Figure 13: The flow process chart for the organisation**

## 4.2 Value stream mapping for the production process

The value stream map can be seen below in Figure 14. It illustrates the value-adding activities, non-value-adding but required activities, and the wasteful activities in the production process at the organisation.

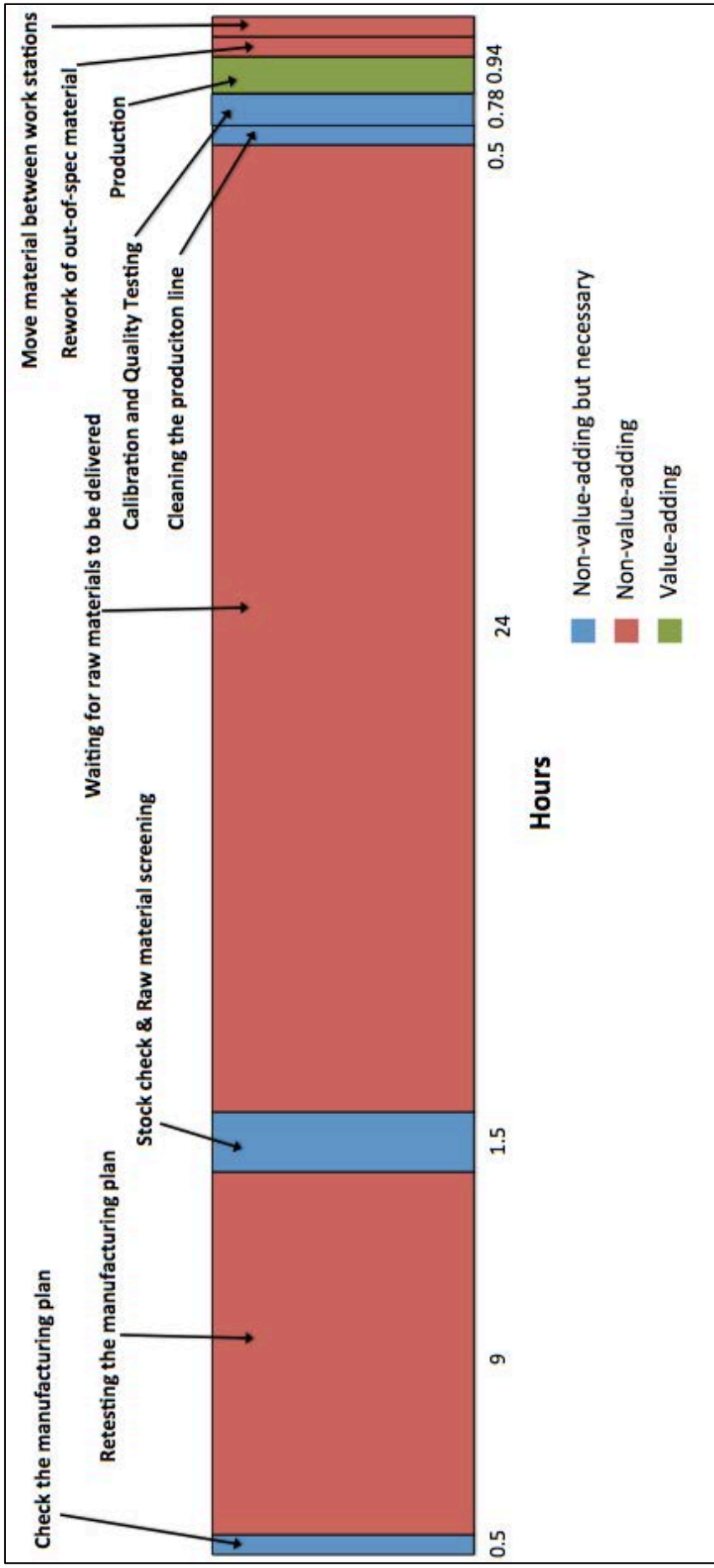

Figure 14: The value stream map for the production process

In the value stream map (Figure 14), the non-value-adding, but necessary, activities are illustrated in blue. These activities were:

- Ensuring that the manufacturing plan for the material is correct.
- Stock check of the raw material levels and screen testing the incoming raw material.
- Cleaning the production line.
- Calibration and quality control.

These activities are all necessary, so they cannot be removed.

#### **4.2.1 Wasteful activities at the organisation**

The activities that contributed nothing to the customer, and could be considered as wasteful activities (as explained in paragraph 2.1.1.4.1), are illustrated in red (Figure 14). These activities were:

1. Retesting of laboratory test samples, as this is only necessary due to poor record keeping.
2. Waiting for receipt of ordered raw materials.
3. Reworking of out-of-specification product.
4. Excessive movement of product between workstations.

These activities were analysed in paragraph 4.4 to determine the root cause of the problem (5-Why analysis to determine the root causes). These four wasteful activities were the problems that had to be addressed in the optimization plan.

### 4.3 The process flow diagram

The process flow diagram of the production process can be seen below in Figure 15. The arrows indicated the movement of the process, and the symbols correspond to the flow process chart in Figure 13. The process starts at the office with process 1, and moves in direction of process 10 at the wrapping station. There are two production lines that are not in operation at the same time, as there are not enough labourers to operate both production lines at the same time. The one line is used for dry finished product only, and the second was used for pre-wetted materials, containing oil or tar. Separate production lines are required, as the production line for pre-wetted product would contaminate the production line for the dry finished product. The raw materials are collected from the raw storage area and taken to the batching stations by one forklift. This forklift continuously supplies the production line with batching materials as required. Once the batch had been mixed, bagged and stitched, it was packed onto pallets. A second forklift transports a pallet of finished product, weighing 1 ton, to the wrapping station. Once wrapped, the pallet is taken to the final product bay by the same forklift.

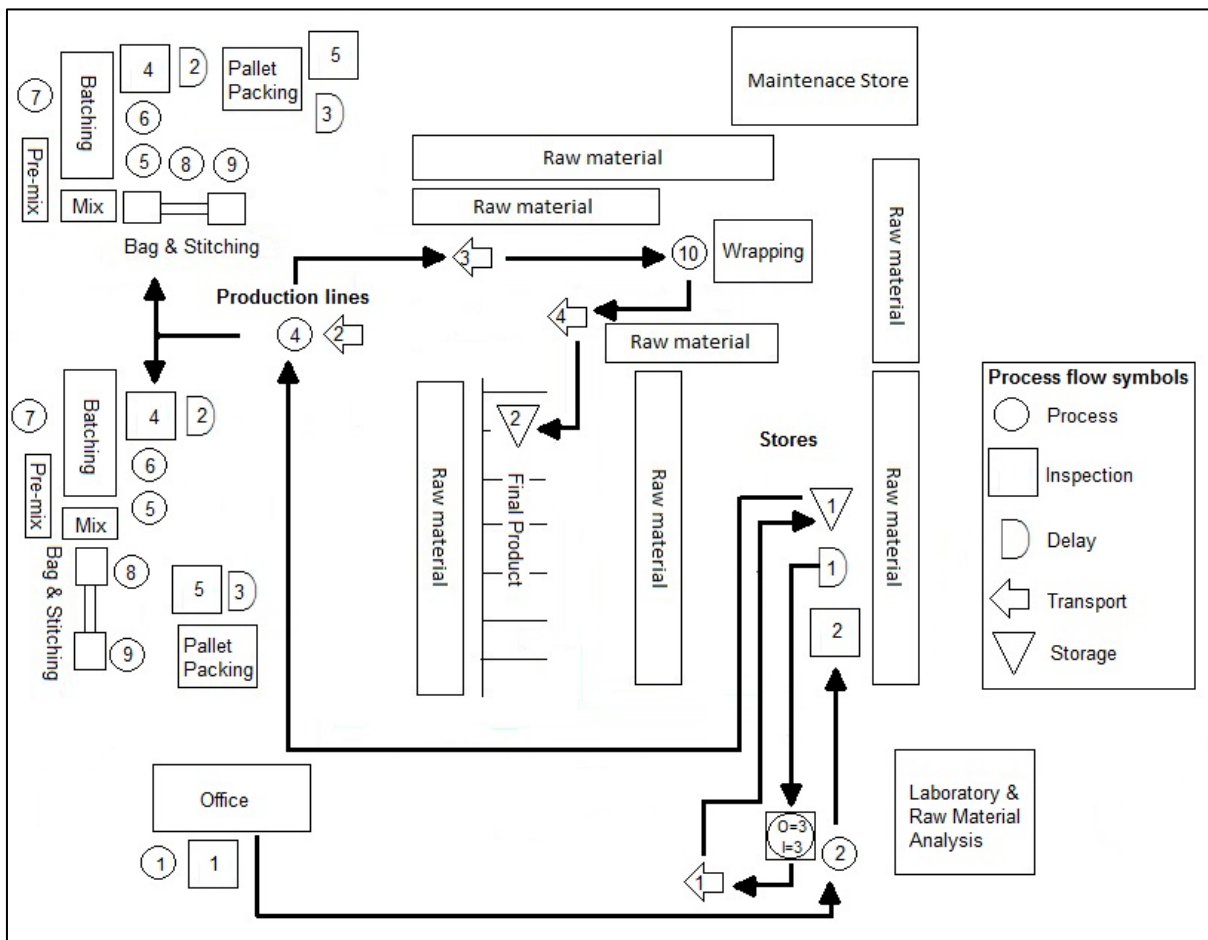

Figure 15: The process flow diagram

#### **4.4 5-Why analysis to determine the root causes**

To determine the root causes of the wasteful activities found in paragraph 4.2.1 (Wasteful activities at the organisation); the 5-Why analysis was used according to Lean Manufacturing (paragraph 2.1.1.13). In order to determine the causes of the problem, the question of why the problem existed, was asked. From that answer, the question of “why?” was asked again another four times, to reach the root cause level 5. These root cause levels for wasteful activities will be discussed below and will form part of the optimization plan.

The following representatives were interviewed as part of the 5-Why analysis:

- The managing director (Greeff, F.A., 2013)
- The financial director (Greeff, S.C., 2013)
- The operation manager (Pretorius, 2013)
- The quality control representative (Hënn, 2013)

##### **4.4.1 Problem: Unnecessary retesting of laboratory test samples**

1. Why? Due to poor recordkeeping in the laboratory the tests results were incomplete or missing.
2. Why? The laboratory manager does not enforce proper recordkeeping.
3. Why? The recordkeeping process is time consuming.
4. Why? The data collected during testing was recorded on paper sheets and all calculations have to be done by hand.
5. Why? The data was recorded on paper because of reluctance from the laboratory manager to move to a computerised system.

##### **4.4.2 Problem: Waiting for raw materials**

1. Why? Insufficient levels of raw materials.
2. Why? Stock levels were not replenished after a previous order had been filled.
3. Why? The raw material levels are not monitored.
4. Why? No minimum levels have been determined for the raw materials.

#### **4.4.3 Problem: Excessive movement of product**

1. Why? The wrapping station is far away from the production lines.
2. Why? There is only one wrapping station and there is no space for it to be closer to the production lines.
3. Why? The initial layout of the production lines did not consider this.
4. Why? Lack of experience.
5. Why? The business moved to new premises in 2008 and the second production line was then added. Before then no one realised the effect two production lines would have on the floor layout.

#### **4.4.4 Problem: Rework of out-of-specification final product**

1. Why? Laboratory results of quality control conducted during production found final product to be out-of-specification.
2. Why? Variations in measuring of quantities and ratios of raw materials occurred during the production process.
3. Why? Variations occurred because shortcuts were taken by the production department.
4. Why? The correct procedure is time consuming and the personnel do not understand the importance of following the procedure.
5. Why? An environment exists where small deviations from the procedures are constantly allowed, causing the personnel to deviate from the procedures when it suits them, not knowing what the consequences will be.

### **4.5 Summary**

The problems are summarised with their root causes, as well as the proposed solutions, in Table 3.

These proposed solutions were used to create the optimization plan in Chapter 5. The operational measures were used to determine the estimated effects these solutions would have on the bottom-line.

**Table 3: The summary of the wasteful activities, root causes and proposed solutions**

<b>Number</b>	<b>Problem</b>	<b>Root cause</b>	<b>Solution</b>
<b>1</b>	Unnecessary retesting of laboratory test samples	Manager's reluctance to change to a computerised system resulted in a great deal of paperwork, which is always incomplete or missing due to time constrictions.	Appoint a clerk to take responsibility for the recordkeeping and procedures in the laboratory. The clerk must not be employed in the laboratory at present, or report to the laboratory manager.
<b>2</b>	Waiting for raw materials	Raw materials are not replenished because no one is monitoring the stock levels and maintaining a minimum requirement.	Make a combined departmental effort to determine minimum amounts of raw materials and empower one person/stock manager to maintain minimum stock levels.
<b>3</b>	Excessive movement of product	The workstations were placed too far apart due to lack of experience.	Rearrange the floor plan to minimise excessive movement.
<b>4</b>	Rework of out-of-specification final product	Deviations from the procedures due to unwillingness to follow procedures.	Train the employees and managers on the importance of following the procedures.

## **5 Optimization plan and estimated improvements**

Using the results found in the investigation, a plan for improvement, or optimization plan, was created using the methodologies from the literature survey to solve the root causes of the problems as summarised in Table 3.

Each problem, with its root cause and proposed solution, is discussed separately as well as the separate effect that each solution would have on the operational measures - throughput, inventory and operating expense. The combined effect that the optimization plan would have on the operational measures is calculated based on the increase in profit from sales.

### **5.1 Eliminating the need to retest laboratory test samples**

As the root cause for poor recordkeeping in the laboratory was identified as the laboratory manager's reluctance to change to a computerised system, it was decided that the recordkeeping process must become a clerk's responsibility.

The proposed solution is to place the Safety, Health, Environment and Quality control (SHEQ) officer in charge of recordkeeping in the laboratory. It will be his responsibility to implement and maintain a computerised recordkeeping system in the laboratory. He will not report to the laboratory manager, and is already responsible for the internal audits and quality control procedures of the entire organisation. Therefore, it would be in line with his other duties.

The computerised recordkeeping system would simply replace the paper-based recordkeeping procedures that are already in place, but it would speed up the process and thereby allow for better data recording, without keeping the laboratory assistant away from his duties.

#### **5.1.1 Effect on throughput**

If retesting of test samples could be eliminated, then the lead-time of a product could be shortened. Apart from the benefit of decreased lead-time on the purchase order, the delay also resulted in lost operating hours. An average waiting period of 10.87 hours was calculated in the time and motion study in Appendix A: Time and motion study, for the laboratory to retest test samples.

According to Greeff, F. A. (2013), who managed the communication of a new purchase order to the laboratory and the production department, on average the production department had to wait 3 times per month for the laboratory to retest test samples. The following could then be calculated:

$$10.87 \text{ hours} \times 3 \frac{\text{times}}{\text{month}} = 32.61 \text{ waiting } \frac{\text{hours}}{\text{month}}$$

$$32.61 \text{ hours} \times 12 \text{ months} = 391.31 \text{ waiting } \frac{\text{hours}}{\text{year}}$$

As the average production rate was 2.216 tons/hour, according to the production reports in Appendix C: Total production and operating hours, the increase in additional production that could have been produced per year, can be determined as:

$$2.216 \frac{\text{tons}}{\text{hour}} \times 391.31 \frac{\text{hours}}{\text{year}} = 867 \text{ tons per year}$$

The average total tons of material produced per year was 5084.575 tons (Appendix C: Total production and operating hours). The estimated increase in production as a percentage of the current total production per year can be calculated as follows:

$$\frac{867}{5084.575} \text{ tons per year} \times 100 \% = 17 \%$$

An estimated increase of 17 % in the average total tons produced per year would be the result, were it not necessary to wait for retesting.

### 5.1.2 Effect on inventory

The inventory of raw materials and final product would not be affected directly by eliminating the need to retest laboratory test samples, as the raw materials used in the laboratory is a very small percentage of the total inventory.

### 5.1.3 Effect on operating expense

The effect on the operating expense could be determined by calculating the total operating expense that was wasted on standing hours as calculated in paragraph 5.1.1. The average production cost per operating hour was R2 233.40 (Appendix C: Total production and operating hours). As the manufacturing plan can only be finalised once the laboratory test have been completed, production cannot start. This means that the production lines are not

working and the labourers have nothing to do. The total operating cost spent per year on standing time would then be:

$$\frac{R2\,233.40}{\text{hour}} \times 391.31 \frac{\text{hours}}{\text{year}} = R873\,951.75 \text{ per year}$$

With the average total operating expense, or production overheads, per year at R5 145 273.04 (Appendix D: Bottom-line measures based on TOC), the estimated average decrease in operating expenses based on the total annual operating expense, can then be calculated as:

$$\frac{R\,873\,951.75}{R\,5\,145\,273.04} \times 100\% = 17\%$$

## 5.2 Eliminating the need to wait for raw materials

A proper stock take system is needed to monitor essential raw material levels, in order to allow the stock manager to order raw materials in advance when a minimum level has been reached and needed to be replenished. The procedure needs to be revised and monitored properly, as part of the quality control process.

A combined input has to be considered that involves the financial, purchasing and production departments. The physical space available and the logistical aspects of the distance and cost to obtain the raw materials have to be taken into account.

The purchase of raw materials can be expensive. If all the raw materials that are their minimum buffer had to be replaced at once, it would cause cash-flow problems within the organisation. It is, therefore, suggested that the raw materials should be divided into categories, such as “used often, in large quantities”, “used seldom”, or “used in very small quantities”. Alternatively, they can be divided into “high”, “medium” or “low” priority, according to the usage history. These categories can be used to determine which raw materials must be replaced first. If cash flow is restricted, then the less critical raw materials that are used seldom or in very small quantities can be replaced in the following months. A minimum level must be indicated and a “pull” system, based on Lean Manufacturing, must be used to determine when that buffer has been depleted, as described in paragraph 2.1.1.3 (Principle 3: Use “pull” systems to avoid overproduction). A visual indicator of the buffer should be placed next to the raw materials so that all staff could see when such a level has been reached. This, along with the traditional stock list, will ensure that raw materials are being monitored by all the production staff involved. All staff must be trained to observe

stock levels and to report stock-related problems to their line managers, so that it may be escalated to the stock controller.

With this guideline for minimum stock levels based on the “pull” system from Lean Manufacturing, one person can take ownership of the purchasing list. The ideal situation would be for the store assistant that conducted the weekly stock checks, to have the minimum stock levels for raw materials indicated on his checklist. Once the check was completed, he can write a purchase note, to be approved by the stock controller, for the required amount of raw materials. The purchase note would then be given to the purchasing department to place the orders. Allowances should be made by the stock controller for the purchasing department to adjust the amounts by a small degree if the transporter or supplier required a certain minimum order.

### **5.2.1 Effect on throughput**

According to Greeff, F.A. (2013), the need to wait for raw materials occurred on average four times per month, based on the delay of supplying material to clients who needed it urgently. As the average waiting time for raw materials was calculated as 2.27 days according to the time and motion study in Appendix A: Time and motion study, the lead time of the product would increase with an average of 2.27 days, four times each month.

As there are eight working hours per day, the 2.27 days spent waiting, will consist of 18.16 working hours. The production line was not used continually, as the steps in the procedure before production can start are still required. These are the steps as listed in Figure 13 (The flow process chart for the ). The time that elapsed from the first step – ensuring that the manufacturing plan is correct to the last step before production – calibrating the scales was 215.53 minutes, or 3.59 hours. This was calculated by adding the times from the flow process chart in Figure 13 for these steps together. That would mean that 14.57 operating hours were lost due to waiting for the raw materials. The following could then be calculated:

$$14.57 \text{ hours} \times 4 \text{ times per month} = 58.28 \text{ hours spent waiting per month}$$

$$58.28 \text{ hours} \times 12 \text{ month} = 699.36 \text{ hours spent waiting per year}$$

As the average production rate was 2.216 tons/hour, according to the production reports in Appendix C: Total production and operating hours, the decrease in production could be determined as follows:

$$2.216 \frac{\text{tons}}{\text{hour}} \times 699.36 \text{ hours} = 1\,549.78 \text{ tons lost due to waiting}$$

Therefore, 1 549.78 additional tons of product could have been produced per year, had it not been for time wasted due to waiting for raw materials.

As the average annual production, or total tons produced per year, was 5 084.575 tons (Appendix C: Total production and operating hours), the increase in throughput had time not been wasted, can be calculated as follows:

$$\frac{1\,549.78}{5\,084.575} \text{ tons per year} \times 100\% = 30.48\%$$

### 5.2.2 Effect on inventory

The list of raw materials with their minimum required levels, was determined by the production, Pretorius (2013) and financial departments, Greeff, S.C. (2013). The raw materials were prioritised according to frequency of use, the average amount used and the level of difficulty of obtaining these raw materials. The priority levels were classified as “high”, “medium” and “low”. A shortened example of this list can be seen in Appendix E: Prioritisation and buffer levels of the raw materials.

If all of these raw materials were to be increased to their minimum buffer levels, the total expense of the raw materials would amount to R2 194 915.37 (Appendix E). As the average annual inventory was R15 496 506.87, according to Appendix D: Bottom-line measures based on TOC, the total increase in inventory would be 14 %, if the additional expense were calculated as a percentage of the average annual inventory. As this would be a once-off expense that will only occur in the first financial year, this increase was not used to calculate the effect from the optimization plan. Once the buffers have been created, the raw material purchasing trends will continue as before, and the average profit will increase because the income from sales of final product will balance out with the purchase of raw materials.

The raw materials could also be acquired in a staggered fashion, according to their priority level, to spread out the expense of raising all raw material levels to their determined minimum levels.

### 5.2.3 Effect on operating expense

The effect on the operating expense can be determined by calculating the total operating expense that was wasted on standing hours. The average cost per operating hour was R2 233.40 (Appendix C: Total production and operating hours). The total operating cost spent on standing time per year, calculated in paragraph 5.2.1 was:

$$\frac{R2233.40}{\text{hour}} \times 699.36 \text{ hours} = R1\ 561\ 950.62 \text{ per year spent on standing time}$$

The average operating expense per year was R5 145 273.04 (Appendix D: Bottom-line measures based on TOC). Had standing time not occurred, the estimated average decrease in operating expenses can be calculated as a percentage of the total annual operating expenses, as follows.

$$\frac{R1\ 561\ 950.62}{R5\ 145\ 273.04} \times 100 \% = 30.36 \%$$

### 5.3 Eliminating excessive movement of product during production

The two production lines were placed away from each other (as seen in Figure 15) to create space for the two forklifts to pass each other. One forklift can be used to both feed the production line with raw material and transport the finished material between the pallet station and the wrapping station, but a second forklift is used for the transportation of the finished product to speed up the production process. This is adding more cost to production, as an extra driver is required, as well as increased fuel consumption and maintenance. The solution for the production rate is, therefore, causing the process to perform non-optimally.

By rearranging the floor layout of the production plant, the production lines can be moved closer together so that the wrapping station can be placed at the end of both production lines. The pallet packing and wrapping can occur at the same location, eliminating the need for the pallets to be transported between these stations. The second forklift will no longer be required to move the finished product, as the first forklift will only need to move it to the finished product bay, which it can do between raw material runs. The proposed floor layout can be seen in Figure 16.

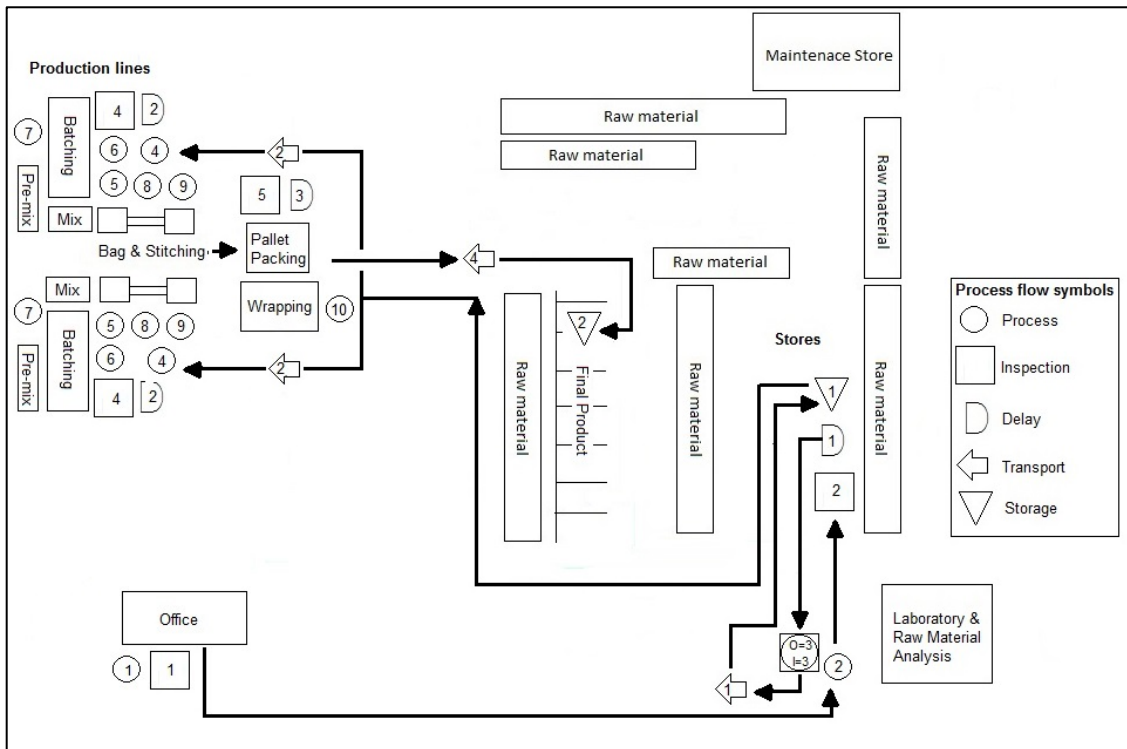

**Figure 16: The proposed optimization of the production plant layout**

As the second forklift was required for offloading incoming raw material as well as helping with the production line, the remaining forklift will have to off-load incoming raw materials if it arrives while the production line is in action. This might cause a pile-up at the workstations if the forklift cannot transport the materials quick enough.

However, the pile-up of product will only occur between the wrapping station and the final product bay. Because the raw materials are loaded in 1-ton bulk bags at a time, and each mix will only require a percentage of each bag, the bags are not changed regularly and the forklift can quickly load the new bags between off-loading the material from the trucks. The pallets at the wrapping station have to be changed with every ton of finished product, which according to the average production rate in Appendix C: Total production and operating hours, is 2.216 tons/hour. This still will not cause a great problem if the off-loading of the trucks has to be interrupted, but if a pile-up does occur, the pallets at the wrapping station can be moved aside with a manual pallet forklift. The organisation already owns a manual pallet forklift, so there will not be any additional costs.

### 5.3.1 Effect on throughput

The forklift has to transport the pallet of final product from the pallet packing workstation to the stretch-wrapping station. According to the time and motion study in Appendix A, the average distance travelled during this step is 35.79 m. Based on the specifications of the forklift (Hyster Europe, 2014) the average speed that the forklifts can travel is 16.7 km/h, which can be converted to 4.64 m/s. Based on this speed, it would take the forklift 7.7 seconds to transport the pallet of finished product to the wrapping station. If the production plant was rearranged, as proposed in Figure 16, the forklift would no longer be required to transport the pallet of final product between these two stations. As each pallet contains a ton of final product, it could be assumed that this would decrease the production time per ton of final material, with 7.7 seconds, which means that a ton of finished materials can be produced 7.7 seconds faster than before.

The average production rate was 2.216 ton/hour (Appendix C: Total production and operating hours). To convert this to a rate of ton/second, it must be divided by 60 minutes and divided again by 60 seconds:

$$\frac{2.216 \frac{\text{tons}}{\text{hour}}}{60 \frac{\text{minutes}}{\text{hour}}} = 0.0369 \frac{\text{tons}}{\text{minute}}$$

$$\frac{0.0369 \frac{\text{tons}}{\text{minute}}}{60 \frac{\text{seconds}}{\text{minute}}} = 0.000615 \frac{\text{tons}}{\text{second}}$$

To convert this rate to the amount of seconds it takes to produce a ton of finished material, the inverse is calculated:

$$\frac{1}{0.000615 \frac{\text{tons}}{\text{second}}} = 1\,626 \text{ seconds/ton}$$

If 7.7 seconds was gained on average for each ton of final product produced, then the rate 1 626 seconds/ton will be decreased with 7.7 seconds:

$$1\,626 - 7.7 = 1\,618.3 \text{ seconds/ton}$$

To determine the production rate tons/second, the inverse must be calculated again and the rate converted to tons/hour as follows:

$$\frac{1}{1\,618.3 \frac{\text{seconds}}{\text{ton}}} = 0.000618 \text{ tons/second}$$

$$0.000618 \frac{\text{tons}}{\text{second}} \times 60 \frac{\text{seconds}}{\text{minute}} = 0.03708 \text{ tons/minute}$$

$$0.03708 \frac{\text{tons}}{\text{minute}} \times 60 \frac{\text{minutes}}{\text{hour}} = 2.2248 \text{ tons/hour}$$

Therefore, if the unnecessary movement of the material between the production line and the wrapping station can be eliminated, the estimated average increase in the annual production rate would be:

$$\frac{(2.2248 - 2.216)}{2.248} \times 100 \% = 0.4 \%$$

### 5.3.2 Effect on inventory

Inventory levels would not be affected as no additional raw materials would be required and once final product had reached its buffer, production would be suspended.

### 5.3.3 Effect on operating expense

As the second diesel-powered forklift can be removed from the production process, it can be assumed that the operating expense for the forklift will be halved, as there were only two forklifts. The average total expense for the forklifts was R321 873.29 (Appendix B: Total expense for the organisation). If it is to decrease with 50%, then the estimated decrease in cost for the forklifts will be R160 936.64 per year.

According to Appendix D: Bottom-line measures based on TOC, the average operating expense for the entire production process, or production overheads, are R5 145 273.04. The decrease in operating expense caused by the removal of one of the diesel-operated forklifts can then be calculated as follows:

$$\frac{R\,160\,936.64}{R\,5\,145\,273.04} \times 100 \% = 3.13 \%$$

## 5.4 Eliminating the need to rework out-of-specification final product

As the root causes for the out-of-specification final product was due to the unwillingness of the labourers and managers to follow the procedures, the ideal situation would be to minimise the need for manual labour as far as possible. To automate the entire production plant would, however, require a significant financial investment that could not be justified at the time. The solution would be to train the employees and the managers on the importance of the procedures to ensure that no mistakes are made during the mixing process.

### 5.4.1 Effect on throughput

The average amount of rework was not documented, therefore, the exact percentage of rework could not be determined. According to Greeff, F.A. (2013), the estimated average rework was 12 tons per month, based on complaints that was received from customers during the past year as well as internal quality control tests. The following can then be calculated:

$$12 \text{ tons per month} \times 12 \text{ months} = 144 \frac{\text{tons}}{\text{year}}$$

If the rework of the 144 tons of out-of-specification product could be eliminated, then based on the average annual production of 5 084.575 tons per year (Appendix C: Total production and operating hours), the average increase in throughput would be:

$$\frac{144}{5\,084.575} \text{ tons per year} = 2.8 \% \text{ per year}$$

### 5.4.2 Effect on inventory

In order to rework the out-of-specification product, additional raw materials have to be taken from inventory. In most cases, a raw material has to be added to increase its percentage in the mix, or if there is too much of a certain raw material, several others had to be added to lower its percentage in the mix. In either case, there will be excess final product after rework, which will also lead to waste, as it will need to be scrapped.

Additional raw materials had to be purchased to rectify the out-of-specification product and inventory would increase. As there is no record of rework or scrapped material, the effect on inventory cannot be determined precisely.

According to Greeff, F.A. (2013), approximately half of the out-of-specification material was found by the internal quality control tests before the product was dispatched. This meant that adjustments could be made to the material and it did not need to be scrapped. The other half of the out-of-specification materials were already dispatched and had to be replaced. This then means that at least 50% of the raw materials used for the 144 tons of out-of-specification material had to be replaced, which would be 72 tons per year. This can be determined as a percentage of the total average production of 5084.575 tons per year, (Appendix C: Total production and operating hours) as follows:

$$\frac{72 \text{ tons per year}}{5084.575 \text{ tons per year}} = 1.41 \% \text{ of total production to replace raw material}$$

It can be assumed that the average annual expense on raw materials, R14 574 756.63, (Appendix B: Total expense for the organisation), will also decrease with 1.41 % as it will not be necessary to replace raw materials.

The packaging for the out-of-specification material was also scrapped. The average packaging cost per ton of final product is R178.09 (Appendix C: Total production and operating hours). Therefore, if the manufacturing of out-of-specification final product could be eliminated, then the decrease in inventory of packaging material will be as follows:

$$\frac{R178.09}{\text{ton}} \times 144 \text{ tons} = R25\,644.96 \text{ less packaging per year}$$

The average annual expense on inventory was R15 496 506.87 (Appendix D: Bottom-line measures based on TOC). The estimated decrease in inventory would then be:

$$\frac{R25\,644.96}{R15\,496\,506.87} \times 100 \% = 0.17 \%$$

The combined effect of the decrease in raw materials and the decrease in packaging material would then decrease inventory with:

$$1.41 \% + 0.17 \% = 1.58 \%$$

### 5.4.3 Effect on operating expense

According to Appendix C: Total production and operating hours, the average production rate was 2.216 tons/hour. The operating hours that could be gained by eliminating the rework of the 144 tons of out-of-specification product would be:

$$\frac{144 \text{ tons}}{2.216 \frac{\text{tons}}{\text{hour}}} = 65 \text{ operating hours gained}$$

At an average cost per operating hour of R2 233.40 (Appendix C: Total production and operating hours), the operating expense for this out-of-specification product could be determined as follows:

$$65 \text{ hours} \times \text{R}2\,233.40 = \text{R}145\,171.00 \text{ per year}$$

Based on the average annual operating expense of R5 145 273.04 (Appendix D: Bottom-line measures based on TOC), the estimated decrease in operating expense due to the elimination of this additional expense, can be calculated as:

$$\frac{\text{R}145\,171.00}{\text{R}5\,145\,273.04} \times 100 \% = 2.8 \%$$

The expense of the wasted raw materials could also be added to the operating expense, but as there was no official record of rework of out-of-specification material, it cannot be determined accurately.

## 5.5 Summary

The estimated results from the optimization plan and the combined decrease in operating expense can be seen below in Table 4.

**Table 4: The estimated effect of the optimization plan**

Number	Problem	Root cause	Solution	The estimated effect on		
				Throughput	Inventory	Operating expense
1	Retesting of laboratory test samples are required	Manager's reluctance to change to a computerised system	Appoint a clerk that does not work in the laboratory or report to the laboratory manager, to take responsibility for recordkeeping procedures	+17 %	0 %	-17 %
2	Waiting for raw materials	No single department or person can make the decision of what raw materials should be replenished as there are no predetermined limits or guidelines	Make a combined departmental effort to determine minimum amount of raw materials and empower one person to make the decisions of when stock should be ordered	+30.48 %	0 %	-30.36 %
3	Excessive movement of product	Production lines were placed far apart because of lack of experience when adding a second production line	Rearrange the floor layout to minimise excessive movement	+0.4 %	0 %	-3.13 %
4	Rework of out-of-specification final product	Shortcuts are being taken because the employees do not understand the importance of the prescribed procedures	Train the employees on the procedures as well as the importance of following them to maintain he correct quality	+2.8 %	-1.58 %	-2.8 %
<b>Total</b>				<b>+50.68 %</b>	<b>-1.58 %</b>	<b>-53.29 %</b>

The total estimated effect of the optimization plan in Table 4 was used to determine what the effect on the profit would be. The changes in the operational measures would each affect certain other measures. The effect the changes from the optimization plan would have on the actual values of the operational measures can be seen below in Table 5.

**Table 5: The effects the changes from the optimization plan would have on the operating measure**

		The actual values of the operational measures		
		Operating expense	Inventory	Throughput
<b>The change caused by the optimization plan</b>	<b>Operating expense</b>	Will be effected	Operating expense does not have an effect on inventory as they are separate expenses	The operating expense of production would not affect throughput
	<b>Inventory</b>	Inventory does not have an effect on operating expense as they are separate expenses	Will be effected	Inventory does not have a direct effect on throughput
	<b>Throughput</b>	Changes in throughput due to increased efficiency would not affect operating expense	Throughput caused an equal increase in inventory	Will be affected

The increase in throughput would affect the value of the income generated from sales of product, as well as the inventory due to the additional expense on raw materials needed for the increase in production. All expenses were included in operating expense and inventory, and all income was derived from throughput.

The value of the actual combined effect from the optimization plan on the operational measures can be seen in Table 6. The value of the effects on each operating measure, as illustrated in Table 5, were indicated in the cells below each operational measure. The throughput was calculated by taking the average of the sales income for the same period as the inventory and operating expenses. The profit and profit percentage increase from sales indicated the combined effect on the bottom-line from the optimization plan. The percentage increase in profit was determined to be a 14.67 %.

**Table 6: The combined estimated effect of the optimization plan**

		Operational measures			
		Income	Total expense		
		Throughput	Inventory	Operating Expense	Profit
<b>Current values</b>		R28 019 998.80	R15 496 506.87	R5 145 273.04	R7 378 218.89
			R20 641 779.91		26.33%
<b>% changes caused by the optimization plan</b>					
Throughput	50.68%	50.68 %	50.68%	No effect	
Inventory	-1.58%	No effect	-1.58 %	No effect	
Operating expenses	-53.29%	No effect	No effect	-53.29 %	
<b>Total percentage effect on the operational measures</b>		50.68 %	45.22%	-53.29 %	
<b>Improved values</b>		R42 220 534.19	R22 504 027.28	R2 403 357.04	R17 313 149.88
		<b>% profit increase from sales</b>			41.01%
					14.67%

## 5.6 The prioritisation of the problems in the optimization plan

As not all the problems can be addressed at once in the optimization plan, the problems have to be prioritised. They were prioritised based on the effect that they will have on the operating expense, as the profit will increase by lowering the cost of production, as indicated by Lean Manufacturing. If the problems are eliminated then the operating expense will decrease for the organisation. The prioritisation can be seen below in Table 7.

**Table 7: the prioritisation for the optimization plan**

Item number	Problem	Score based on reduction of operating expense	Priority
1	Retesting of laboratory samples	-17 %	2
2	Waiting for raw materials	-30.36 %	1
3	Excessive movement of product	-3.13 %	4
4	Rework of out-of-specification final product	-2.8 %	3

Based on the scoring and prioritisation of the problems according to the effect on the operating effect the optimization must then be implemented in the following order in Table 8:

**Table 8: The optimization plan priority and solutions**

Order	Problem	Solution
1	Waiting for raw materials	Determine the minimum amounts of raw materials and empower one person/stock manager to maintain minimum stock levels.
2	Retesting of laboratory test samples	Appoint a clerk to take responsibility for the recordkeeping and procedures in the laboratory.
3	Rework of out-of-specification final product	Train the employees and managers on the importance of following the procedures.
4	Excessive movement of product	Rearrange the floor plan to minimise excessive movement

## 6 Discussion of results

A critical evaluation of the results from the optimization plan will be discussed in this chapter.

### 6.1 The results from the combined effect of the optimization plan

Based on the improved values estimated in Table 6, the following graphs were created to visualise the potential improvements due to the optimization plan.

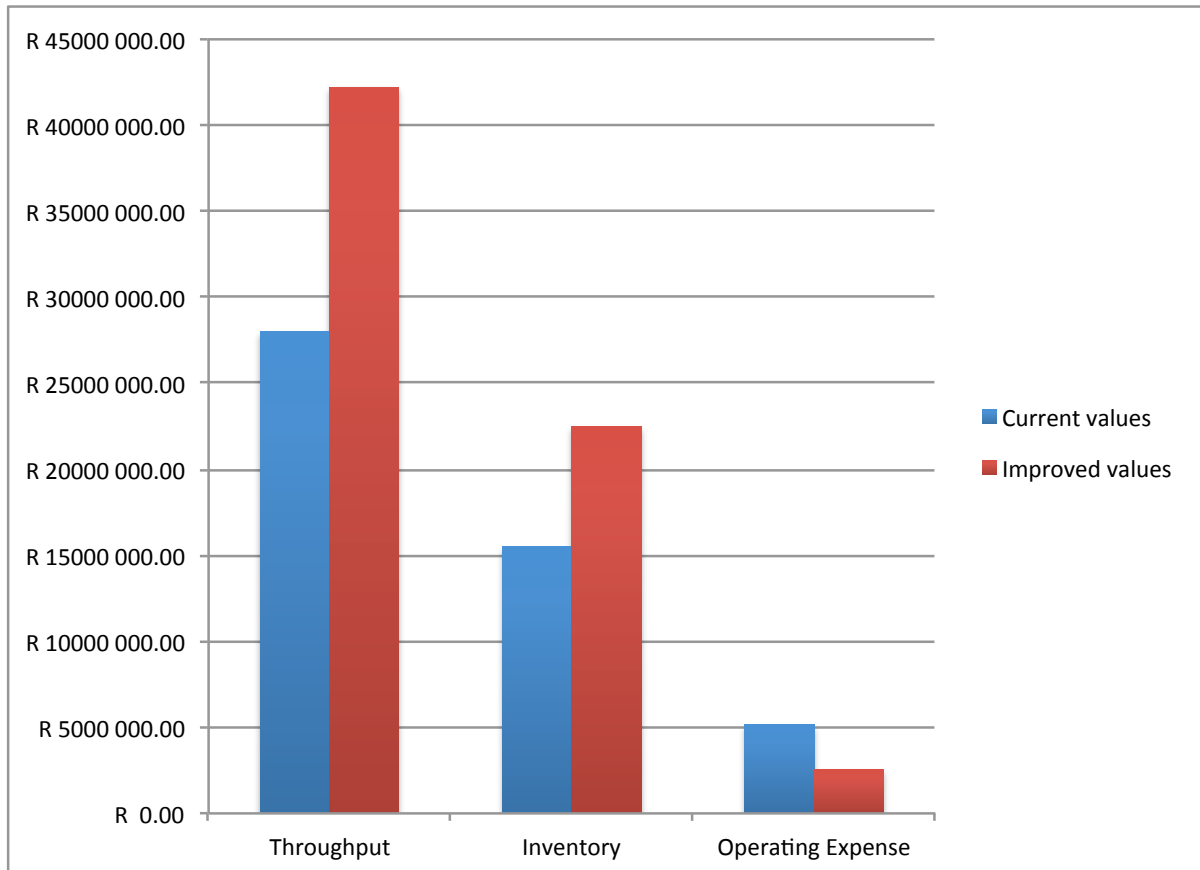

**Graph 1: The estimated combined effect on the operational measures**

From Graph 1 it can be seen that the throughput would be increased significantly. This would be caused by the increase in the production rate resulting from the optimization plan. The inventory would also be increased, as a direct result of the increase in throughput, since more raw materials would be required by the increase in production rate. The operating expense would be decreased as the increase in production rate would cause the average operating cost per hour to decrease.

To determine the profit increase the following graph was created:

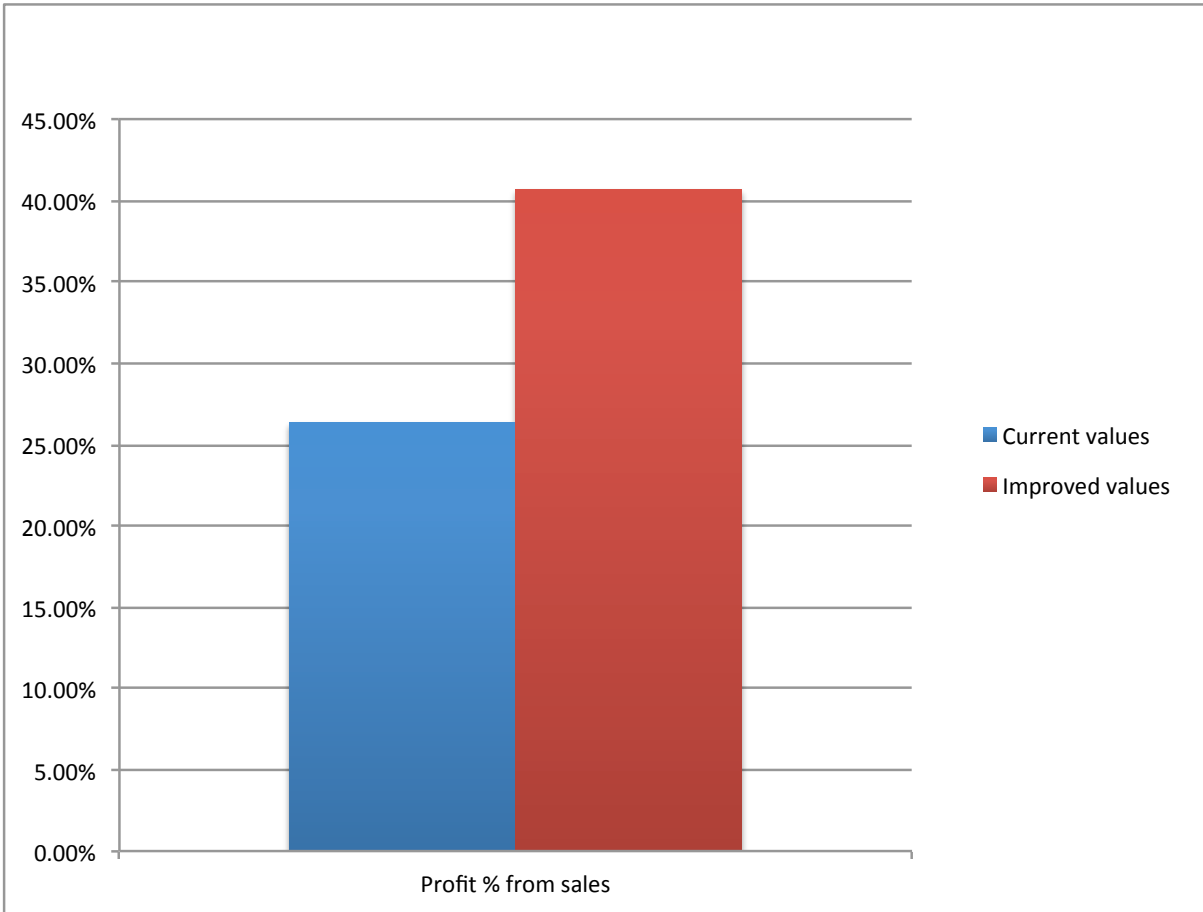

**Graph 2: The effect of the optimization plan on profit from sales**

Graph 2 illustrates the effects these changes in the operational measures would have on the percentage profit made from sales of product, as illustrated in Table 6. The profit had increased by 14.67 % even though the inventory had increased, which is undesirable based on TOC. However, the increase in inventory is not caused by unused stock or finished product that is accumulating in the stores, it is simply because more raw materials need to be purchased to create the finished product that will increase due to the increase in production rate.

The profit increased because of an increase in income from sales of product that was caused by the increase in throughput.

Together, the increased throughput and inventory would cause the expense of the organisation to increase. The increased throughput would cause an increase in income from sales. This would result in the increase in profit, as illustrated in Graph 2.

## **7 Future research and continuous improvement**

During the investigation, several problems surfaced that could not be investigated accurately due to a lack of the correct recordkeeping procedures. The following suggestions were made for future research and continuous improvement.

### **7.1 Create a schedule for internal audits**

In order to identify problems or constraints causing the organisation to function non-optimally, regular internal audits of all the processes are needed. A schedule for continued internal audits must be created, as this will ensure that the improvements that were implemented are still in place and that those solutions implemented, are in fact the solutions to the wasteful activities identified by the 5-Why analysis in paragraph 4.4. This would allow for overall continued improvement in the organisation.

### **7.2 Monitor the production process**

Many of the values that were used to determine the effect that the optimization plan will have on the operational measures were assumed, such as the total amount of out-of-specification material produced, or the exact amount of time that the production lines are being used. It is suggested that these variables be monitored and recorded. The actual improvements can then be monitored using these values and further optimization can be suggested once a more in-depth study has been conducted.

## **8 Conclusion**

It was concluded after considering all the information gained throughout this research, that the implementation of the optimization plan would be a viable solution for the organisation.

The actual percentage changes caused in the profit may vary, but the profit from sales will increase due to the optimization of the production process. Continued research into improvement of the process, would ultimately lead to further improved processes and bottom-line results at the organisation.

It is also the opinion of the financial director, S.C. Greeff, that “this optimization plan looks very promising. Any increase in profit is always a good thing, and the amount of effort and change that we have to make to get it, is not that much. I believe that this can work”.

## 9 References

BLACKSTONE, J. 2010. Theory of constraints.

[http://www.scholarpedia.org/article/Theory\\_of\\_Constraints](http://www.scholarpedia.org/article/Theory_of_Constraints) Date of access: 28 January 2013

CEVIKCAN, E., KILIC, H.S., & ZAIM, S. 2012. Proceedings of the 2012 International Conference on Industrial Engineering and Operations Management Istanbul, Turkey July 3 – 6, 2012: Westinghouse method oriented fuzzy rule based tempo rating approach.

DU TOIT, P.J. & BERGER, M.B. 2010. Role of refractories. (Lecture delivered as part of the course in refractories in metallurgical industries at the Council for Science and Industrial Research on 21 and 22 April 2010). Pretoria. (Unpublished)

FREEDONIA GROUP. 2011. World refractories.

[http://www.reportbuyer.com/industry\\_manufacturing/materials/world\\_refractories.html](http://www.reportbuyer.com/industry_manufacturing/materials/world_refractories.html) Date of access: 2 July 2012

GOLDRATT, E.M. & COX, J. 2004. The goal: a process of ongoing improvement. 3<sup>rd</sup> ed. Great Barrington: North River Press.

GOLDRATT, E.M. & FOX, R.E. 1986. The race. Croton-on-Hudson: North River Press.

GREEFF, F.A. 2013. Verbal communication with the author. South Africa

GREEFF, L. 2013a. Photograph. The organisation. South Africa

GREEFF, L. 2013b. Photograph. The organisation South Africa

GREEFF, L. 2013c. Photograph. The organisation. South Africa

GREEFF, S.C. 2012. Production reports for the organisation, dated 2009 – 2012.  
(Unpublished)

GREEFF, S.C. 2013. Verbal communication with the author. South Africa

GULIN CRUSHERS. 2010. Portable concrete plants.

<http://www.gulincrusher.com/crushing-plant/portable-concrete-plants.html> Date of access:  
30 October 2013.

HëNN, J.H.D. 2013. Verbal communication with the author. South Africa

HYSTER EUROPE. 2014. Fortens IC counterbalanced lift trucks: S2.0-2.5FT Fortens  
advance/Fortens advance+. <http://viewer.zmags.com/publication/375fd029#/375fd029/6>  
Date of access: 29 October 2014

JAPAN MANAGEMENT ASSOCIATION. 1989. *Toyota no genba kanri: kanban hoshiki no  
tadashii susumetkata*. Translated from Japanese by David J. Lu. Portland: Productivity  
Press, Inc.

KPMG. 2011. Steel sector outlook: Expectations for the industry in today's economic  
context. [https://www.kpmg.com/ZA/en/IssuesAndInsights/ArticlesPublications/General-  
Industries-Publications/Pages/Global-Steel-Sector-Outlook-June-2010.aspx](https://www.kpmg.com/ZA/en/IssuesAndInsights/ArticlesPublications/General-Industries-Publications/Pages/Global-Steel-Sector-Outlook-June-2010.aspx) Date of access:  
2 July 2012

LIKER, J.K. 2004. The Toyota way: 14 management principles from the world's greatest  
manufacturer. USA: McGraw-Hill. p 310

INDIAN INSTITUTE OF TECHNOLOGY, DELHI (IITD). 2014. National program on technology enhanced learning: Industrial engineering, Lecture 1.

[http://nptel.tvm.ernet.in/courses/Webcourse-contents/IIT-ROORKEE/INDUSTRIAL-  
ENGINERRING/part1/lecture1.htm](http://nptel.tvm.ernet.in/courses/Webcourse-contents/IIT-ROORKEE/INDUSTRIAL-<br/>ENGINERRING/part1/lecture1.htm) Date of access: 27 October 2014.

PAWLIK. G. 2009. Toyota System perspective.

[http://www.thetoyotasystem.com/lean\\_concepts/toyota\\_system\\_perspective.php](http://www.thetoyotasystem.com/lean_concepts/toyota_system_perspective.php) Date of access: 11 July 2012

PRETORIUS, E. 2013. Verbal communication with the author. South Africa

SOUTH AFRICA. 1996. National Small Business Act No. 102 of 1996. Pretoria: Government Print.

SUBASINGHE, D.S.S.C.P. 2009. Time and Motion Study for the Department of Mechanical Engineering, University of Peradenyia.

<http://www.pdn.ac.lk/eng/old/mechanical/menu/class/downloads/notes/Time%20&%20Motion%20Study.pdf> Date of access: 27 October 2014.

THE AMERICAN SOCIETY OF MECHANICAL ENGINEERS. 1947. ASME Standard: Operation and flow process charts. New York: The American society of mechanical engineers. p 21

THE INTERNATIONAL ORGANISATION FOR STANDARDISATION. 1985. International standard ISO 5807: International processing – Documentation symbols and conventions for data, program and system flowcharts, program network charts and system resources charts. Switzerland: International Organisation for Standardisation. p 26

TOYOTA. 2011. Jidoka – Manufacturing high-quality products. [http://www.toyota-global.com/company/vision\\_philosophy/toyota\\_production\\_system/jidoka.html](http://www.toyota-global.com/company/vision_philosophy/toyota_production_system/jidoka.html) Date of access: 13 August 2011

PIGAGE, L.C. & TUCKER, J.L. 1954. Time and motion study. *University of Illinois Bulletin*, 51(73):1-60, June.

WICAKSANA, S. 2013. Motion and time study based on Work systems and the methods, measurements and management of work by M.P. Groover. <http://www.slideshare.net/wicaksana/motion-and-time-study-23381791>. Date of access: 2 October 2014

## Appendix A: Time and motion study

**Table 9: Time and motion study for the organisation**

Time and motion study for the organisation																		
Process description	Observation			Average distance	Average time	Rating factor					Normal time and motion	PFD				Standard time and motion		
	1	2	3			Skill rating	Effort	Environmental conditions	Consistency	Rating factor		Personal	Fatigue	Delay	PFD Rating			
Receive order																		
Ensure that the manufacturing plan is correct (min)	22	35	33		30.00	0.15	0.05	0.00	0.00	1.20	0.00	0.00	1.20	0.05	0.04	0.05	0.14	37.14
Test the manufacturing plan in the lab (hours)	8.5	11.5	7		9.00	0.08	0.05	-0.03	-0.02	1.08	-0.02	0.00	1.08	0.05	0.05	0.05	0.15	10.87
Inspect the raw material levels (min)	30	90	120		80.00	0.03	-0.04	0.02	0.01	1.02	0.01	0.00	1.02	0.05	0.06	0.05	0.16	82.76
Wait for ordered materials (days)	1	2	0.5		1.17	0.00	0.00	0.00	0.00	1.00	0.00	0.00	1.00	0.05	0.00	0.05	0.10	2.27
Receive and screen raw material (min/ton)	36	27	34		32.33	0.08	-0.04	-0.03	0.00	1.01	0.00	0.00	1.01	0.05	0.05	0.05	0.15	33.81
Move accepted raw materials into store (m)	17	33	21	24		0.03	0.00	0.02	0.01	1.06	0.01	0.00	1.06	0.05	0.04	0.05	0.14	26.23
Store material until requisitioned																		
Clean the production line (min)	22	35	17		24.67	0.03	0.08	-0.07	0.01	1.05	0.01	0.00	1.05	0.05	0.07	0.05	0.17	27.07
Move material from the store to the production line (m)	83	137	148	123		0.03	0.00	0.00	0.01	1.04	0.01	0.00	1.04	0.05	0.04	0.05	0.14	128.71
Load the production line (min)	13	28	31		24.00	0.06	0.00	-0.03	0.01	1.04	0.01	0.00	1.04	0.05	0.04	0.05	0.14	26.10

Time and motion study for the organisation (continued)																
Process description	Observation			Average distance	Average time	Rating factor				Normal time and motion	PFD				Standard time and motion	
	1	2	3			Skill rating	Effort	Environmental conditions	Consistency		Rating factor	Personal	Fatigue	Delay		PFD Rating
Check the material against the manufacturing plan (min)	2	7	4		4.33	0.06	0.02	-0.03	0.00	1.05	4.55	0.05	0.05	0.05	0.15	5.70
Inspect the calibration of the scales (min)	1	2	2		1.67	0.06	0.05	-0.03	0.00	1.08	1.80	0.05	0.05	0.05	0.15	2.95
Calibrate the scales (min)	19	27	22		22.67	0.06	0.50	0.00	0.00	1.56	35.36	0.05	0.05	0.05	0.15	36.51
Premixing and batching of materials into the trolley (min)	7	9	12		9.33	0.06	0.08	-0.03	0.01	1.12	10.45	0.05	0.06	0.05	0.16	11.61
Mixing of the materials (min)	11	10	10		10.33	0.03	0.00	0.00	0.03	1.06	10.95	0.05	0.04	0.05	0.14	12.09
Bag the material and stitch the bags (min)	6	4	9		6.33	0.03	0.05	0.00	0.01	1.09	6.90	0.05	0.05	0.05	0.15	8.05
Test the quality control samples of every fifth batch (min)	12	13	9		11.33	0.08	0.02	-0.03	0.00	1.07	12.13	0.05	0.05	0.05	0.15	13.28
Wait for approval of quality control samples (min)	13	14	11		12.67	0.00	0.00	0.00	0.00	1.00	12.67	0.00	0.00	0.00	0.00	13.67
Move the product to the wrapping station (m)	33	35	31	33		0.00	0.00	0.02	0.03	1.05	34.65	0.05	0.04	0.05	0.14	35.79
Wrap the pallets of finished product (min)	7	11	13		10.33	0.03	0.08	-0.03	0.03	1.11	11.47	0.05	0.06	0.05	0.16	12.63
Move the material to the finished product bay (m)	37	48	4	30		0.03	0.00	0.00	0.03	1.06	31.45	0.05	0.04	0.05	0.14	32.59
Store the finished product until dispatch																

## Appendix B: Total expense for the organisation

Table 10: Total expense for the organisation from 2009 – 2012 (Greeff, S.C., 2012)

	2012	2011	2010	2009	Average
<b>Operating expenses</b>					
<b>Building</b>	<b>R1 239 203.91</b>	<b>R1 108 180.79</b>	<b>R855 661.73</b>	<b>R619 326.05</b>	<b>R955 593.12</b>
Building rental	R750 000.00	R715 000.00	R653 088.00	R508 770.00	R656 714.50
Refuse removal	R41 340.42	R46 092.70	R25 533.53	R15 956.20	R32 230.71
Water & electricity	R438 695.75	R339 009.00	R169 356.00	R85 346.00	R258 101.69
Security	R9 167.74	R8 079.09	R7 684.20	R9 253.85	R8 546.22
<b>Maintenance</b>	<b>R350 140.60</b>	<b>R329 786.42</b>	<b>R394 214.74</b>	<b>R223 686.32</b>	<b>R324 457.02</b>
<b>Quality control</b>	<b>R156 719.57</b>	<b>R179 460.73</b>	<b>R166 975.21</b>	<b>R68 472.17</b>	<b>R142 906.92</b>
Quality - Laboratory	R3 993.86	R25 093.00	R16 420.85	R21 397.30	R16 726.25
Quality wages	R152 725.71	R154 367.73	R150 554.36	R47 074.87	R126 180.67
<b>Packaging</b>	<b>R1 221 252.90</b>	<b>R628 311.80</b>	<b>R1 182 136.10</b>	<b>R655 300.17</b>	<b>R921 750.24</b>
<b>Table continued on next page</b>					

**Total expenses for the organisation (continued)**

	2012	2011	2010	2009	Average
<b>Forklift</b>	<b>R390 628.08</b>	<b>R331 461.71</b>	<b>R278 720.30</b>	<b>R286 683.05</b>	<b>R321 873.29</b>
Rental	R141 030.08	R128 825.76	R177 415.19	R187 397.64	R158 667.17
Maintenance	R9 890.87	R11 872.30	R4 888.58	R17 586.49	R11 059.56
Diesel	R239 707.13	R190 763.65	R96 416.53	R81 698.92	R152 146.56

**Operating expenses**

<b>General</b>	<b>R302 356.33</b>	<b>R369 897.64</b>	<b>R273 597.79</b>	<b>R210 657.93</b>	<b>R289 127.42</b>
Gas	R21 472.30	R76 171.10	R30 527.91	R17 087.50	R36 314.70
Internet charges	R29 237.03	R25 635.04	R4 934.82	R4 378.50	R16 046.35
Vehicles	R51 163.01	R68 126.42	R44 572.95	R37 489.07	R50 337.86
Stationary	R22 196.58	R21 213.54	R19 664.52	R19 979.94	R20 763.65
Telephone	R90 360.13	R127 694.00	R117 982.15	R92 908.45	R107 236.18
PPE	R40 536.15	R14 500.15	R15 047.33	R13 810.01	R20 973.41
Safety	R47 391.13	R36 557.39	R40 868.11	R25 004.46	R37 455.27

**Table continued on next page**

<b>Operating expenses (continued)</b>						
<b>Salaries &amp; Wages</b>	<b>R3 848 070.94</b>	<b>R3 160 272.15</b>	<b>R3 047 525.49</b>	<b>R2 389 392.50</b>	<b>R3 111 315.27</b>	
Insurance - Life	R191 412.51	R175 249.80	R192 666.04	R178 199.00	R184 381.84	
Salaries monthly staff	R2 708 410.43	R2 326 381.37	R2 289 932.59	R1 716 655.53	R2 260 344.98	
Wages - Production	R948 248.00	R658 640.98	R564 926.86	R494 537.97	R666 588.45	
<b>Total expenses for the organisation (continued)</b>						
	<b>2012</b>	<b>2011</b>	<b>2010</b>	<b>2009</b>	<b>Average</b>	
<b>Inventory</b>						
<b>Raw materials</b>	<b>R18 111 244.64</b>	<b>R15 096 884.45</b>	<b>R15 298 156.68</b>	<b>R9 792 740.73</b>	<b>R14 574 756.63</b>	
Total raw materials expense for production and stock-levels combined	R17 739 090.20	R15 004 331.85	R15 188 904.98	R9 762 477.73	R14 423 701.19	
Stainless steel fibre & anchors	R372 154.44	R92 552.60	R109 251.70	R30 263.00	R151 055.44	

## Appendix C: Total production and operating hours

Table 11: Total production and operating hours for 2009 – 2012 (Greeff, S.C., 2012)

Production reports for the organisation for 2009 - 2012						
	2012	2011	2010	2009	Average	
Total tons produced per year	5 449	4 862	5 624	4 403	<b>5 084.575</b>	
Average production rate (ton/hour)	2.348	2.061	2.473	1.984	<b>2.216</b>	
Operating hours per year	2332	2350	2291	2213	<b>2 296.5</b>	
Average production (cost/ton)	R1 153.78	R1 126.86	R891.95	R862.73	<b>R1 008.83</b>	
Average production (cost/hour)	R2 696.02	R2 331.51	R2 189.74	R1 716.32	<b>R2 233.40</b>	
Average packaging (cost/ton)	R224.12	R129.22	R210.18	R148.85	<b>R178.09</b>	

## Appendix D: Bottom-line measures based on TOC

Table 12: Bottom-line measures based on TOC for 2009 – 2012 (Greeff, S.C., 2012)

Total Expenses based on TOC measurements					
	2012	2011	2010	2009	Average
Production overheads	R6 287 119.43	R5 479 059.44	R5 016 695.26	R3 798 218.02	R5 145 273.04
Inventory for production and stock-levels	R19 332 497.54	R15 725 196.25	R16 480 292.78	R10 448 040.90	R15 496 506.87
<b>Total Expenses</b>	<b>R25 619 616.97</b>	<b>R21 204 255.69</b>	<b>R21 496 988.04</b>	<b>R14 246 258.92</b>	<b>R20 641 779.91</b>

## Appendix E: Prioritisation and buffer levels of the raw materials

**Table 13: Prioritisation and buffer levels of raw materials at the organisation (Pretorius, 2013)**

Priority	Raw material name	Grade	Units	Minimum stock level	Maximum stock level	Stock levels	Difference between stock and minimum buffer	Cost price per ton of material	Cost of increasing stock to required minimum
High	ALSIL P (PYROPHILITE)	As Rec	ton	2	5	5.7		R2 252.00	R-
High	Alumina Cement CA 50-G7	As Rec	ton	3	15	0	3	R5 385.00	R16 155.00
High	Alumina Cement Secar 71	As Rec	ton	1	5	0	1	R18 230.00	R18 230.00
High	Alumina CTC50	As Rec	ton	1	5	1.55		R24 650.00	R-
High	Alumina Dispersing ADS 3	As Rec	ton	0.5	2	0.275	0.225	R62 600.00	R14 085.00
High	Alumina Dispersing M-ADS1	As Rec	ton	0.5	1	0.125	0.375	R63 650.00	R23 868.75
High	Alumina Dispersing M-ADW1	As Rec	ton	0.8	1.5	0.125	0.675	R63 650.00	R42 963.75
High	Alumina PMR (CTC30)	As Rec	ton	1	2	0.15	0.85	R22 650.00	R19 252.50
High	Alumina Tab	100#	ton	2	5	1	1	R13 150.00	R13 150.00
High	Black Silicon carbide 97% pure	0.0-1.0	ton	5	10	1	4	R20 000.00	R80 000.00
High	Boric Acid Granular	As Rec	ton	1	3	3.525		R13 560.00	R-
High	Calcium Carbide	1.0-2.0	drum	100	500	272		R10 317.00	R-
High	Chrome-alumina slag	1.0-3.0	ton	20	50	6	14	R5 750.00	R80 500.00
High	Culminal cellulose	As Rec	ton	0.05	1	0.025	0.025	R143 520.00	R3 588.00
High	Eccabond N Bentonite	As Rec	ton	1	10	5		R3 445.00	R-
High	FFB 47	As Rec	ton	1	10	0.7	0.3	R45 000.00	R13 500.00
High	Magnesite Brown reclaim	1.0-3.0	ton	10	30	2	8	R4 470.00	R35 760.00
High	SSW 446 melt extract	As Rec	ton	0.5	2	0.06	0.44	R26 500.00	R11 660.00
High	Sulphur (blomswael)	As Rec	ton	0.5	2	0.3	0.2	R7 580.00	R1 516.00
<b>Total expense for high priority raw materials</b>									<b>R1 790 927.70</b>
Medium	Alumina 60% grog	0.0-1.0	ton	20	40	13	7	R2 025.00	R14 175.00
Medium	Chamco	1.0-3.0	ton	20	40	28		R1 715.00	R-
Medium	Soda- Ash Dense Granular	As Rec	ton	0.2	1	0.15	0.05	R3 940.00	R197.00
Medium	Sodium BiCarbonate	As Rec	ton	0	2	1		R4 300.00	R-
Medium	Zircon Sand standard	0.0-1.0	ton	1	2	0.075	0.925	R57 670.00	R53 344.75
<b>Total expense for medium priority raw materials</b>									<b>R179 991.57</b>
Low	Alumina 40% grog	0.0-1.0	ton	15	30	5	10	R1 205.00	R12 050.00
Low	B13-04 Boron phosphate	As Rec	ton	0.5	2	0.9		R34 200.00	R-
Low	Barium carbonate	As Rec	ton	0.1	1	0.3		R10 560.00	R-
Low	Barium sulphate BLANC FIXE	As Rec	ton	0.1	1	0.225		R22 500.00	R-
Low	Fused silica	0.0-0.5	ton	0.25	0.5	0.25	0	R9 300.00	R-
Low	Fused silica	0.5-1.0	ton	0.25	0.5	0.25	0	R9 300.00	R-
Low	Sodium Tripolyphosphate STPP	As Rec	ton	0.5	1.5	0.125	0.375	R13 600.00	R5 100.00
Low	SSW 430 Melt Extract	As Rec	ton	0.5	2	0.42	0.08	R22 660.00	R1 812.80
<b>Total expense for low priority raw materials</b>									<b>R223 996.10</b>
<b>Total expense to increase all raw materials to minimum buffer level</b>									<b>R2 194 915.37</b>