

Cost and energy savings on mine surface cooling systems

TS Moropa
22652183

Dissertation submitted in fulfilment of the requirements for the degree *Master of Engineering* in **Mechanical Engineering** at the Potchefstroom Campus of the North-West University

Supervisor: Dr JH Marais

May 2017

Abstract

Title: Cost and energy savings on mine surface cooling systems
Author: Thabiso S. Moropa
Supervisor: Dr Johan H. Marais
School: North-West University, Potchefstroom Campus
Faculty: Engineering
Degree: Master of Engineering (Mechanical)
Key words: Electricity, deep-level gold mines, energy-intensive mine systems, mine surface cooling systems, energy management, cost savings

The South African national power utility, Eskom, is struggling to meet the high electrical energy demand. The problem is due to the shortage of generating capacities as a result of delays in the building of new power stations. Unplanned maintenance on the existing power stations also adversely affects the power supply. Integrated Demand Management (IDM), a division of Eskom, initiated a Demand Side Management (DSM) programme to achieve energy efficiency and to apply load management to energy-intensive industries.

The South African mining industry consumes approximately 14% of the country's total generated electricity capacity. Gold mines in South Africa are the deepest in the world, reaching depths of up to 4 km. Such depths require large cooling systems to maintain acceptable and productive working conditions. Up to 25% of a mine's total electricity usage is consumed by these large cooling systems. Electricity costs are increasing at a higher rate than inflation. For this reason, mines require more electrical energy saving measures to reduce their operating costs. The increase in operating costs reduces the competitiveness of the mines and thus affects their economic viability.

Deep-level mine surface cooling systems were investigated to identify potential cost and energy savings. Typical surface cooling systems must supply air at approximately 8°C Wet-bulb (WB) to the underground working areas to maintain acceptable working conditions. Lower ambient air temperatures during the evenings reduce the cooling demand, hence the mine surface cooling

systems power load can be reduced during Eskom evening peak period. The reduced power load on the cooling systems during the Eskom expensive evening peak period will result in electricity costs savings for the mine.

A versatile load management strategy was developed, which can be implemented on closed or semi-closed loop mine surface cooling systems. Load reduction tests were conducted on the surface cooling systems of Mine A (closed loop) and Mine B (semi-closed loop) during the Eskom evening peak period. The underground temperatures and relative humidity were monitored during the evening peak period. These tests verified that the strategy can be implemented without adversely affecting the underground working conditions. An Energy Management System (EnMS) was utilised to execute the developed strategy.

The underground temperatures of all three levels (95L, 100L and 110L) at Mine A vary between 23°C WB and 27°C WB after implementation. The underground Bulk Air Coolers (BACs) inlet air temperature on 84 level is monitored at Mine B, and the WB temperatures vary between 17°C WB and 21°C. These temperature ranges are within the operational safety boundaries of the mines. Therefore, the mine surface cooling systems can continuously be offloaded during the Eskom expensive evening peak period.

An average evening load reduction of 1.8 MW was achieved at Mine A, with annual cost savings of R900 000. The load reduction for Mine B was an average of 2.7 MW and was achieved with the annual cost savings of R1.4 million. The developed load management strategy is versatile and can be implemented to any closed or semi-closed loop mine surface cooling system.

Acknowledgements

First of all, I would like to thank the Almighty God for granting me an opportunity to submit this dissertation, I am very much humbled. Indeed, I can do all things through Christ who strengthens me (*Philippians 4:13*).

This dissertation is fully dedicated to my late mother. *“Mom, you passed away a month just before my undergraduate graduation ceremony. That cut me deep; but to honour you, I continued to study further because you believed in education. This dissertation is dedicated to you. I love you Mom.”*

To my family: Collen Moropa, Ricardo Moropa, and Reginald Moropa, thank you guys for fully supporting me, your love is very much appreciated. My uncle, Tebogo Riba, you are a true blessing. Thank you for being there, I really appreciate it. And to my beautiful and loving girlfriend, Tebogo Mokgotho, thank you for your continued love, support, and motivation throughout my studies.

I would like to thank HVAC International (Pty) Ltd, TEMM International (Pty) Ltd and Enermanage for their financial support.

To Prof. Mathews and Prof. Kleingeld, thank you so much for giving me the opportunity to join a dynamic team of CRCED Pretoria. Dr Marais, thank you for supervising me throughout this dissertation. Dr Schutte, thank you for guiding me through everything, which includes academics and self-development. Dr Kriel, thank you for your technical assistance and implementation of the case studies for this dissertation.

Mine A and Mine B personnel: Thank you so much for your assistance with everything, including the technical assistance much appreciated.

Table of Contents

Abstract	i
Acknowledgements.....	iii
List of Figures	vi
List of Tables	ix
Nomenclature	x
Abbreviations	xi
1. Electrical energy demand in South Africa	1
1.1 Introduction	2
1.2 Electricity constraints	3
1.3 Electricity consumption in the mining industry	5
1.4 Problem statement and research objectives.....	8
1.5 Dissertation overview.....	9
2. Mine cooling systems overview.....	10
2.1 Introduction and background	11
2.2 Cooling system configurations.....	17
2.3 Energy cost saving opportunities	20
2.4 Previously implemented DSM initiatives	24
2.5 Conclusion.....	34

3.	Strategy development to achieve cost savings on mine surface cooling systems.....	36
3.1	Introduction	37
3.2	Developing a new operating strategy	37
3.3	Verification of the developed strategy	45
3.4	Conclusion.....	74
4.	Implementation of strategy and results	76
4.1	Introduction	77
4.2	Case Study 1 – Closed loop system	77
4.3	Case Study 2 – Semi-closed loop system.....	86
4.4	Conclusion.....	97
5.	Conclusion and recommendations	98
5.1	Summary of the study	99
5.2	Recommendations	101
6.	References.....	102
7.	Appendices.....	109

List of Figures

Figure 1 - 1: 2015 World Energy issues	2
Figure 1 - 2: Eskom energy sources used for electricity generation	3
Figure 1 - 3: Electricity prices comparison of African countries.....	4
Figure 1 - 4: Global gold production ranks.....	5
Figure 1 - 5: South African mining geothermal gradients	6
Figure 1 - 6: Refrigeration installed capacity increment in South Africa over the years	8
Figure 2 - 1: Typical refrigeration cycle	11
Figure 2 - 2: A generic mine large cooling system flow diagram	13
Figure 2 - 3: Specific cooling power: calculated for general use	14
Figure 2 - 4: Geothermic gradient.....	15
Figure 2 - 5: Mine cooling systems classifications.....	17
Figure 2 - 6: Open loop mine surface cooling system	18
Figure 2 - 7: Semi-closed loop mine surface cooling system	18
Figure 2 - 8: Closed loop mine surface cooling system.....	19
Figure 2 - 9: Underground refrigeration system schematic layout	20
Figure 2 - 10: DSM programmes.....	22
Figure 2 - 11: Eskom Megaflex Tariff structure for summer – low demand.....	22
Figure 2 - 12: Eskom Megaflex Tariff structure for winter – high demand	23
Figure 2 - 13: System layout of the Platinum mine with the proposed infrastructure	25
Figure 2 - 14: Open loop surface cooling system	26
Figure 2 - 15: Water flow control – Condenser	27
Figure 2 - 16: Water flow control - Evaporator	27
Figure 2 - 17: Surface cooling system layout	28
Figure 2 - 18: Mine cooling system layout under investigation	29
Figure 2 - 19: Integration of cooling and ventilation systems	30
Figure 2 - 20: The EnMS generic controllers integrated with VSDs control	32
Figure 3 - 1: Deep-level gold mines investigation methodology flow chart	38
Figure 3 - 2: Methodology that can be followed with a closed loop	41
Figure 3 - 3: Methodology that can be followed with a semi-closed loop	42

Figure 3 - 4: Load management strategy and control layout	43
Figure 3 - 5: EnMS and PLC functional specification flow chart	45
Figure 3 - 6: Mine A surface cooling system layout.....	46
Figure 3 - 7: Evaporator pumps of Mine A surface cooling system.....	49
Figure 3 - 8: Mine A baseline profiles	50
Figure 3 - 9: Mine A underground measuring points	52
Figure 3 - 10: Ambient WB temperatures at Mine A	53
Figure 3 - 11: Mine A 95 level main shaft – air WB outlet temperature.....	54
Figure 3 - 12: Mine A 100 level main shaft – air WB outlet temperature.....	55
Figure 3 - 13: Mine A 110 level main shaft – air WB outlet temperature.....	56
Figure 3 - 14: Mine A surface cooling system proposed power profiles of the simulation.....	57
Figure 3 - 15: Mine A weekday average electricity cost	57
Figure 3 - 16: Mine A weekday average electricity cost	58
Figure 3 - 17: Mine A surface cooling system power profiles of load reduction test.....	59
Figure 3 - 18: Mine A weekday average electricity cost	59
Figure 3 - 19: Mine B surface cooling system layout.....	61
Figure 3 - 20: Mine B underground measuring points.....	62
Figure 3 - 21: Ambient WB temperature at Mine B	63
Figure 3 - 22: 84 level main shaft – air WB outlet temperature	64
Figure 3 - 23: Underground BACs on 84 level – air WB inlet temperature.....	65
Figure 3 - 24: Underground BACs on 120 level – WB outlet temperature	66
Figure 3 - 25: 120 level East-West split – WB inlet temperature.....	67
Figure 3 - 26: Mine B surface and underground cooling system proposed power profiles.....	69
Figure 3 - 27: Mine B weekday average electricity cost	69
Figure 3 - 28: Mine B weekday average electricity cost	70
Figure 3 - 29: Mine B surface and underground cooling system power profiles	70
Figure 3 - 30: Mine B weekday average electricity cost	71
Figure 3 - 31: Mine A surface cooling system load reduction test utilisation	72
Figure 3 - 32: Mine A surface cooling system baseline utilisation.....	72
Figure 3 - 33: Mine A average daily electricity cost	72
Figure 3 - 34: Mine B surface cooling system load reduction test utilisation	73

Figure 3 - 35: Mine B surface cooling system baseline utilisation.....	73
Figure 3 - 36: Mine B average daily electricity cost.....	73
Figure 4 - 1: Mine A surface cooling system.....	78
Figure 4 - 2: Mine A surface cooling system layout - Closed loop configuration.....	79
Figure 4 - 3: 95 level main shaft – WB outlet temperatures.....	80
Figure 4 - 4: 100 level main shaft – WB outlet temperatures.....	81
Figure 4 - 5: 110 level main shaft – WB outlet temperature	82
Figure 4 - 6: Mine A power profiles after implementation.....	83
Figure 4 - 7: Mine A weekday average electricity cost	84
Figure 4 - 8: Mine A weekday average electricity cost	84
Figure 4 - 9: Mine A surface cooling system actual utilisation	85
Figure 4 - 10: Mine A surface cooling system baseline utilisation.....	85
Figure 4 - 11: Mine A average daily electricity cost	86
Figure 4 - 12: Mine B site layout.....	87
Figure 4 - 13: Mine B surface cooling system layout - Closed loop configuration.....	88
Figure 4 - 14: Mine B - Anti-surge water temperature profile	89
Figure 4 - 15: The 8 ML dam level pre-implementation	91
Figure 4 - 16: The 8 ML dam level post-implementation.....	92
Figure 4 - 17: Underground BACs inlet air temperature post-implementation	93
Figure 4 - 18: Mine B power profile after implementation	94
Figure 4 - 19: Mine B weekday average electricity cost	94
Figure 4 - 20: Mine B weekday average electricity cost	95
Figure 4 - 21: Mine B surface cooling surface system actual utilisation.....	96
Figure 4 - 22: Mine B surface cooling system baseline utilisation.....	96
Figure 4 - 23: Mine B average daily electricity cost.....	96
Appendix 1 - Figure 1: Temperature and power profiles during an offload test at Mine B	109

List of Tables

Table 1 - 1: Summary of environmental sustainability metrics	7
Table 2 - 1: DSM projects – daily performance overview	34
Table 3 - 1: Mine surface cooling system control parameters	43
Table 3 - 2: Mine A fridge plant specifications	46
Table 3 - 3: Mine A condenser cooling towers specifications	47
Table 3 - 4: BAC specifications.....	48
Table 3 - 5: Ambient temperature summary for Mine A	53
Table 3 - 6: Temperature summary of 95 level main shaft for Mine A.....	54
Table 3 - 7: Temperature summary of 100 level main shaft for Mine A.....	55
Table 3 - 8: Temperature summary of 110 level main shaft for Mine A.....	56
Table 3 - 9: Ambient temperature summary for Mine B	64
Table 3 - 10: Temperature summary of 84 level main shaft for Mine B	65
Table 3 - 11: Temperature summary of 84 level underground BACs for Mine B.....	66
Table 3 - 12: Temperature summary of 120 level underground BACs for Mine B.....	67
Table 3 - 13: Temperature summary of 120 level, the East-West split point for Mine B	68
Table 4 - 1: Temperature summary of 95 level main shaft for Mine A.....	80
Table 4 - 2: Temperature summary of 100 level main shaft for Mine A.....	81
Table 4 - 3: Temperature summary of 110 level main shaft for Mine A.....	83
Table 4 - 4: 8 ML dam level summary before implementation at Mine B	91
Table 4 - 5: 8 ML dam level summary levels after implementation at Mine B.....	92
Table 4 - 6: Underground BACs inlet air temperature before implementation at Mine B.	93
Appendix 2 - Table 1: Mine A and Mine B power baseline data	110
Appendix 2 - Table 2: Mine A and Mine B load reduction tests data	111
Appendix 2 - Table 3: Mine A and Mine B actual power consumption.....	112
Appendix 3 - Table 1: Mine A and Mine B electricity cost before and after implementation ...	113

Nomenclature

Description	Symbol	Unit
Temperature measurement	°C	Degrees Celsius
Time measurement	h	Hour
Mass flow measurement	kg/s	Kilogram per second
Water flow rate measurement	Q	Cubic metre per second
Power measurement	kW	Kilowatt
Volume measurement	l	Litre
Distance measurement	m	Metre

Abbreviations

BAC	Bulk Air Cooler
COP	Coefficient of Performance
DB	Dry-bulb
DSM	Demand Side Management
EnMS	Energy Management System
IDM	Integrated Demand Management
IEA	International Energy Agency
IPMVP	International Performance Measurement and Verification Protocol
kW	Kilowatt
MS	Main Shaft
M&V	Measurement and Verification
OECD	Organisation for Economic Co-operation and Development
OPC	Open Platform Communications
PGM	Platinum Group Metals
PLC	Programmable Logic Controller
RH	Relative Humidity
SCADA	Supervisory Control and Data Acquisition
SP	Set Point
SS	Services Shaft
TOU	Time of Use
VRT	Virgin Rock Temperature
VSD	Variable Speed Drive
WB	Wet-bulb

1. Electrical energy demand in South Africa

The world is experiencing high electrical energy demand. Some of the causes are highlighted in this chapter.



Chapter 1

¹A coal power station with six cooling condensers. Available: <http://www.gas-sense.co.uk/>

Chapter 1: Electrical energy demand in South Africa

1.1 Introduction

The world is facing a challenge of sustainable energy due to several reasons, such as the increase in human population, low power generating capacities, new technology developments, etc. [1]. An increase in electrical energy costs and the shortage of generating capacities have led major electricity consumers to evaluate their electrical energy usage [2]. For the next 25 years, an average of 1.4% growth in industrial energy consumption is expected [3].

An increase in electricity prices has directly affected spending decisions of industries, households and the overall economic performance [4]. Figure 1 - 1 shows the energy issues the world faced in 2015. It can be noted that energy prices and energy efficiencies stand out with high uncertainty (shown on the y-axis) and high impact (shown on the x-axis), and require urgent attention.

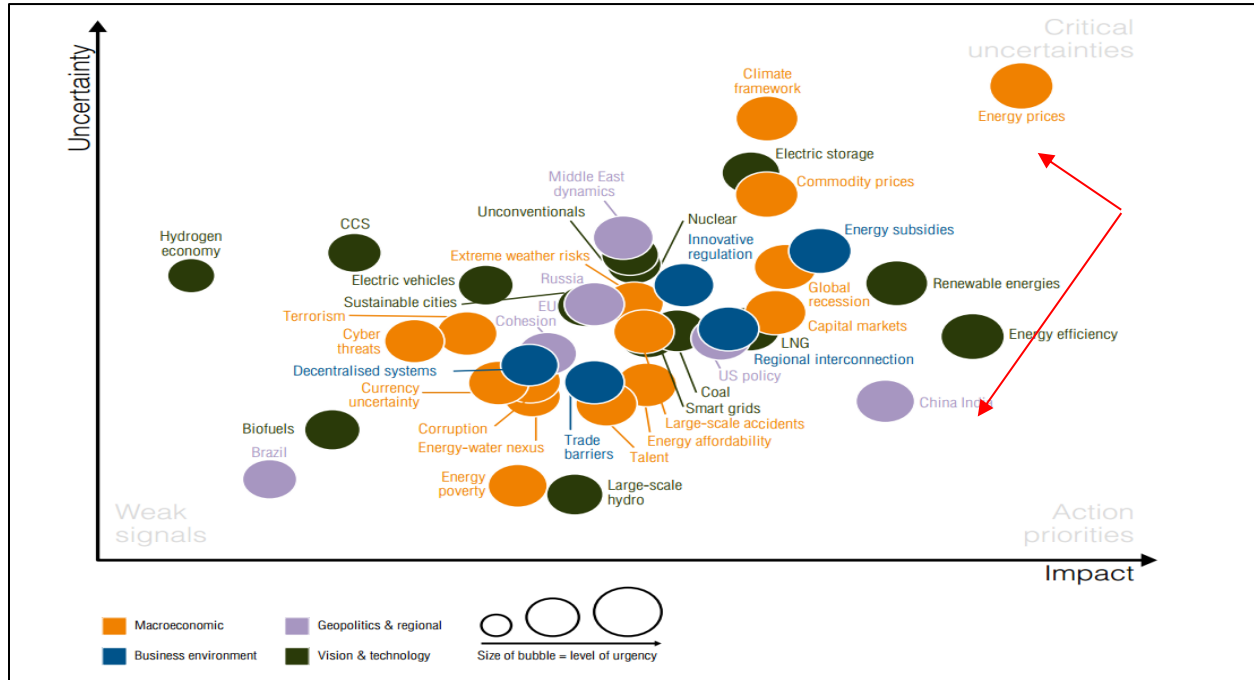

Figure 1 - 1: 2015 World Energy issues [5]²

²Adapted from World Energy Monitor 2015 report. Also available at: <http://www.worldenergy.org/>

Sustainable development is development that meets the needs of the present without compromising the ability of future generations to meet their own needs [6]. It is important to find ways of conserving and utilising the energy for the sake of future generations. Research shows that there are more opportunities for energy efficiency improvements with no reduction of economic growth [3].

1.2 Electricity constraints

South Africa is an extremely energy-intensive economy according to international standards [7]. Economic developments and the increasing population have led to a high electrical energy demand. Eskom, the largest power utility in Africa, had a generating capacity of 41 GW in 2011 [8]. This generated capacity supplies 95% of the South African electrical energy demand, and about 45% electricity demand of other African countries is also supplied by Eskom [9]. South Africa contributes to approximately 42% of emissions in Africa, making it the world’s most non-oil producing carbon intensive country [4].

The electricity generation is predominantly dependent on coal as the source of energy. Currently, 33% of the total coal mined goes to foreign markets. Of the total remaining coal, 55% is utilised for generating electricity, 21% for petroleum products, 4% for gas and the remaining coal is used directly for domestic purposes [10]. About 88% of electricity generated by Eskom is produced from coal, 5% from nuclear energy, and the remainder by other sources [8]. Figure 1 - 2 shows Eskom’s energy sources for electricity generation.

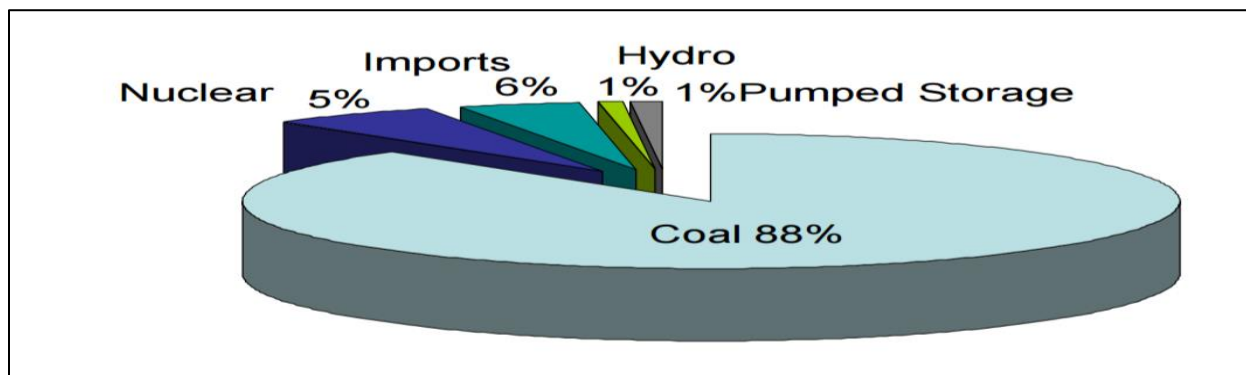

Figure 1 - 2: Eskom energy sources used for electricity generation [11]

Primary electricity usage has increased by an average of 4.3% during the past decade according to International Energy Agency (IEA) data [4]. Due to the abundance of coal resources in the country, Eskom proposed lower electricity prices to government to make South African industries competitive on the international markets [7].

At the moment, South Africa has lower electricity prices compared to other countries. The country lacks energy usage public awareness and this has resulted in little incentive to save electricity [1]. The Department of Energy (DoE) is currently funding most of electrification supply of the disadvantaged households [9].

Figure 1 - 3 shows the statistical electricity prices comparison of some of African countries. South Africa has one of the lowest electricity costs on the continent, resulting in less of a need to conserve electricity. The energy-intensive industries in South Africa remain competitive amongst other African countries because of this low electricity costs. Hence saving of electricity is less of a priority.

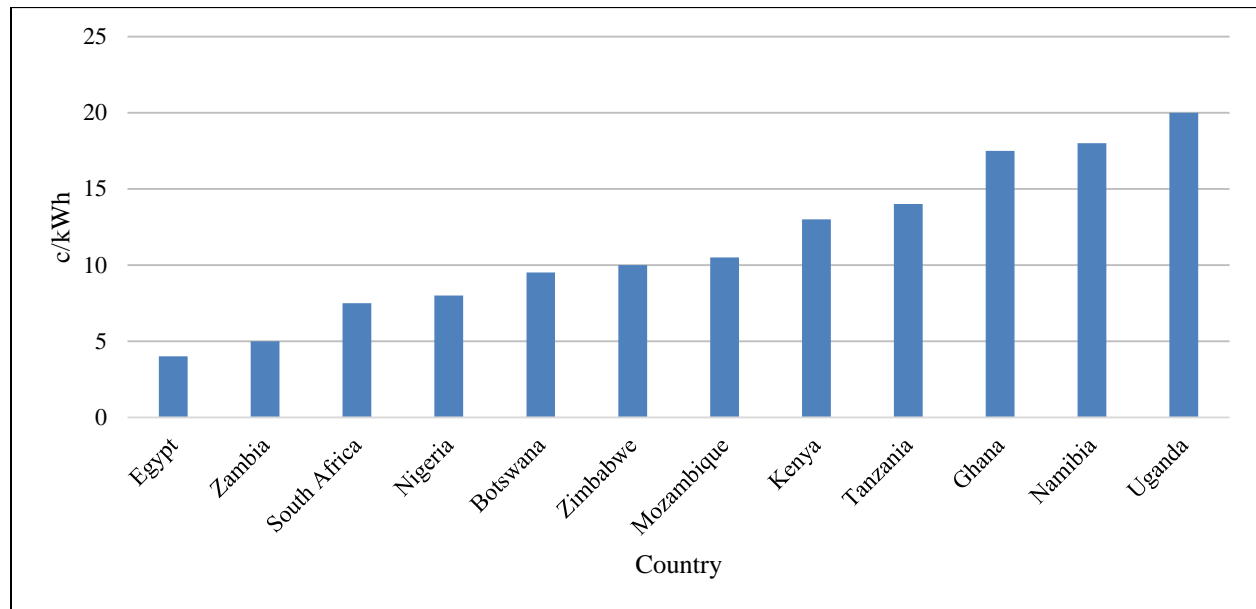

Figure 1 - 3: Electricity prices comparison of African countries (adapted from [12])

1.3 Electricity consumption in the mining industry

Industries consume 37% of the world total generated electricity, and this includes the mining sector [3]. South African industries consume over 70% of the total generated capacity in the country [4]. Mining industry plays an important role in the South African economic growth, but consumes more electricity compared to other countries [13]. Approximately 14% of the national grid is consumed by the mining industry [3], and this is due to the energy-intensive infrastructure.

Figure 1 - 4 shows a comparison between the top 10 gold producing countries. Gold mining is one of the South African major economic contributors. South African mining production has decreased over the last years, and this has impacted negatively on the economy. However, mining operating costs are increasing, and this includes electrical energy costs. The electrical costs increase the mines’ operational costs while the decrease in production causes a decrease in revenue of the mines. As a result some shafts are forced to close because it has become uneconomic to continue mining.

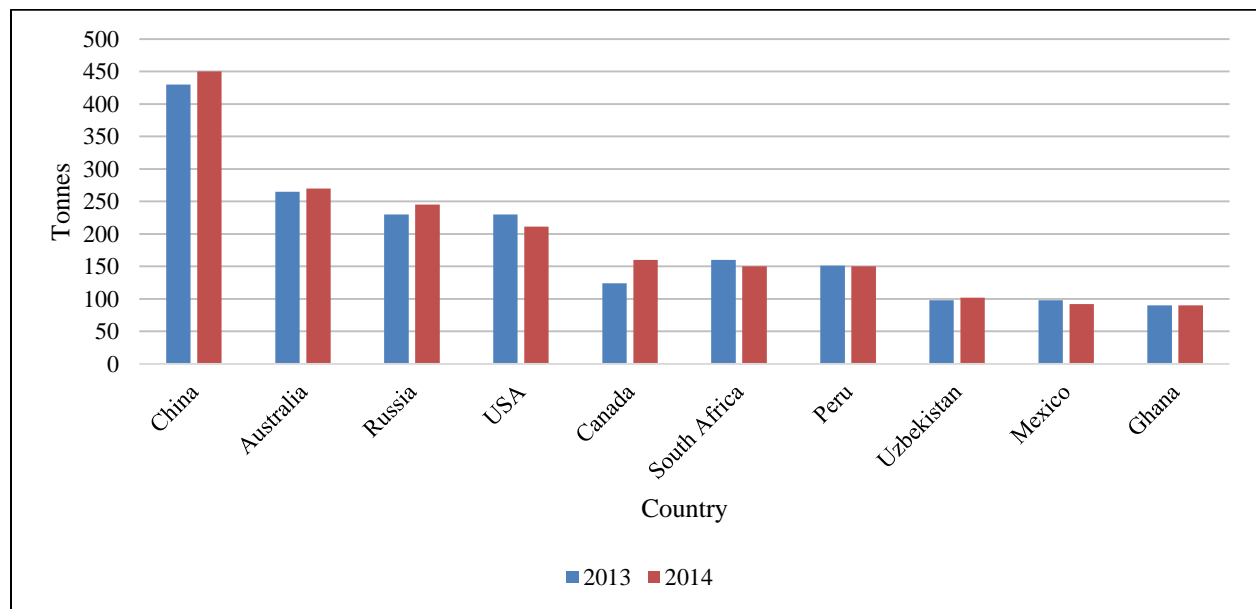

Figure 1 - 4: Global gold production ranks (adapted from [14])

South African deep-level gold mines reach or has been developed to depths of up to 4 km, with Virgin Rock Temperatures (VRT) of 60°C [13]. The mining legislation states that the acceptable underground working conditions should have a WB temperature of less than 27.5°C WB [13]. The deep-level mine temperatures are proportional to the mine depths.

Figure 1 - 5 shows geothermal gradients of typical gold mining regions in South Africa [15]. All the regions illustrated in Figure 1 - 5 have a surface ambient temperature of ±20°C. The Bushveld has the highest gradient and it is the shallowest mining. The Carletonville region has the lowest gradient and has the deepest mining depths. Welkom and Klerksdorp gradients are between the Bushveld and Carletonville regions. The underground temperatures at these mining regions clearly show the need for large cooling systems to be able to maintain acceptable working conditions.

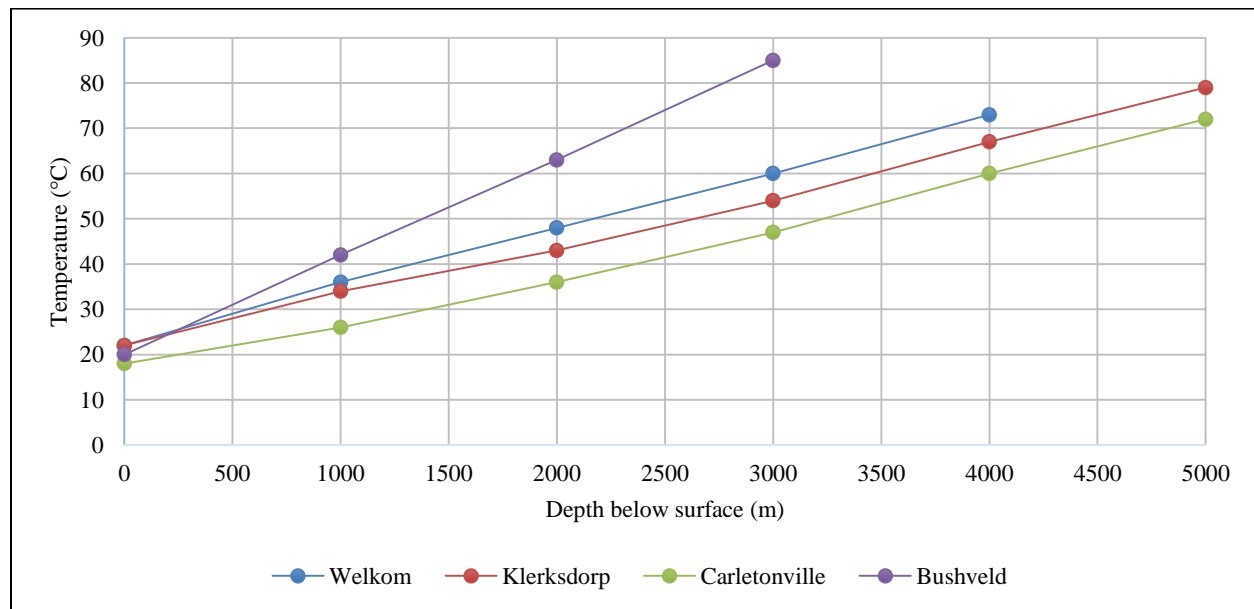

Figure 1 - 5: South African mining geothermal gradients (adapted from [15])

Table 1 - 1 shows a case study that was done by Glaister and Mudd [16] in 2010 on typical South African platinum mines. This study compares production and the electrical energy consumption of each mine. Northam mine is the deepest shown in Table 1 - 1 (2 km deep) and had the highest electrical energy cost [16]. It is evident that the deeper the mine, the higher the mine operational costs due to the required large cooling systems.

Table 1 - 1: Summary of environmental sustainability metrics by Platinum Group Metals (PGM) mines (adapted from [16]).

Individual project/Mine (mine and concentrator)	Mining (MJ/t rock)	Milling (MJ/t ore)	Energy (GJ/kg PGM)	Energy (MJ/t ore)
Bafokeng-Rasimone	239	154	116	409
Lebowa	404	153	164	606
Potgietersrust	21	232	201	500
Amandelbult	292	148	106	465
Rustenburg	295	160	132	475
Union	324	130	190	521
Twickenham	80	-	28.5	107
Mototolo JV	-	170	74.8	196
Mimosa	-	-	107	305
Manila	-	-	108	393
Northam	1268	487	226	1775
Zimplats	-	-	241	710

The impact of this study and other studies has led to a search to find methods and technologies that can achieve energy efficiencies, peak clip, or load shifting. This study focuses mainly on the gold mines, which are one of the biggest electricity consumers in South Africa. Traditionally, the solutions found in the gold mining sector are transferred to platinum mining.

Figure 1 - 6 shows how the refrigeration cooling system installed capacity has increased over the years in the gold mines. The underground temperature increases as the depth of the mine increases, as illustrated in Figure 1 - 5. Therefore, additional cooling capacity is required to keep these temperatures below the maximum allowed limits. Installing large cooling systems means that there will be an increase in operational costs because of the increased electricity costs. The South African deep-level gold mines need to address these high electricity costs to remain competitive in the market.

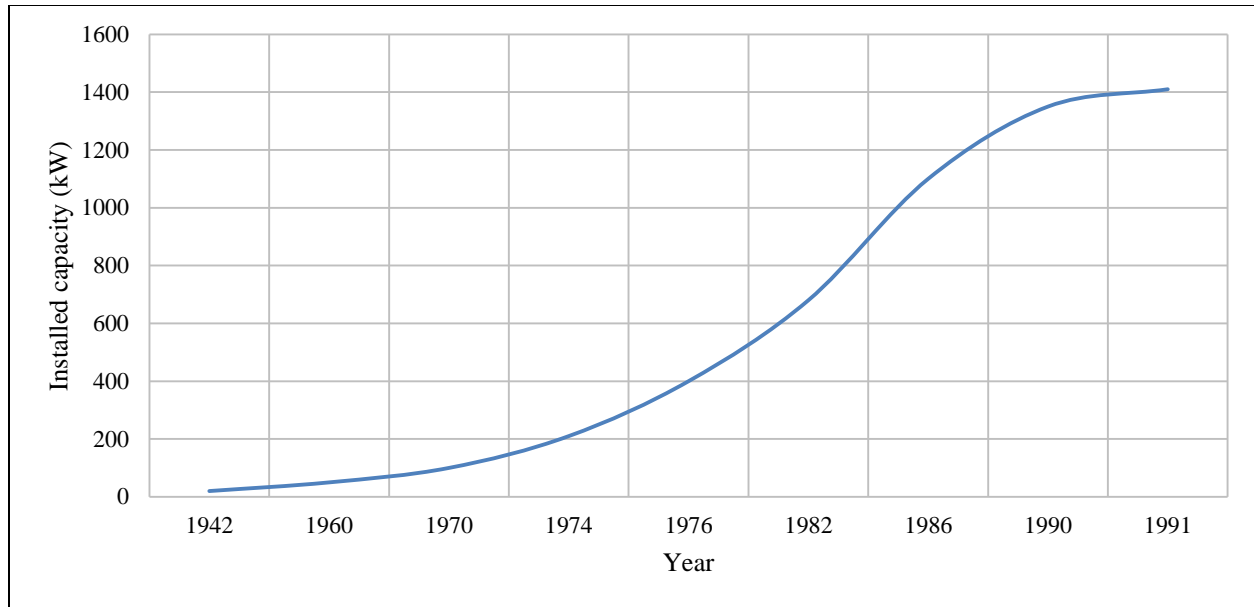

Figure 1 - 6: Refrigeration installed capacity increment in South Africa over the years (adapted from [15])

1.4 Problem statement and research objectives

The shortage of generating capacities and the high electricity demand, prioritises a need for more electricity saving initiatives. Large mine cooling systems on gold mines consume approximately a quarter of a mine’s total operating costs. Several electrical energy saving initiatives have been implemented on cooling systems. The mine surface cooling systems provide cooled air down the main shaft. The favourable low ambient temperatures in the evenings give an opportunity to offload these systems during the evening peak period.

This dissertation focuses on the surface cooling systems of the South African deep-level gold mines. The main objective of this study is to achieve load reduction on the surface cooling systems during the evening peak period. This can be achieved by developing a load management strategy. The load management strategy can be implemented on the mine surface cooling systems without adversely affecting the mines production and safety. EnMS will utilise all the process variables such as the BAC outlet and underground temperatures, fridge plant flow rates, installed capacities, etc. as inputs. This EnMS will be used to execute the developed load management strategy.

1.5 Dissertation overview

Chapter 1: Electrical energy demand in South Africa

Section 1.1 provides a brief background on global electrical energy demand. Section 1.2 focuses on the current situation and history of the South African electrical energy demand. One of the main high electrical energy consuming industry sectors, mining, is elaborated on Section 1.3. Section 1.4 provides an overview and the need for this study. Section 1.5 summarises the chapter.

Chapter 2: Mine cooling systems overview

Section 2.1 is an introduction to the chapter. Section 2.2 focuses on the available deep-level mine cooling systems. Energy cost saving opportunities are presented in Section 2.3. Section 2.4 discusses the previously implemented DSM initiatives on mine cooling systems. Section 2.5 gives a summary based on indicators why there is a need for the load management initiative.

Chapter 3: Optimisation of surface cooling systems

Section 3.1 provides an introduction to the chapter. Section 3.2 focuses on the development of a new operating strategy. Verification of the developed strategy is given in Section 3.3. Section 3.4 concludes the chapter.

Chapter 4: Implementation of strategy and results

Section 4.1 provides an introduction on the implementation of the developed load management strategy. Section 4.2 discusses the post-implementation results of the Case Study 1, closed loop system (Mine A). The post-implementation results of Case Study 2, semi-closed loop system (Mine B), are discussed in Section 4.3. Section 4.4 concludes the chapter.

Chapter 5: Conclusion and recommendations

Section 5.1 provides a summary of the study, evaluation of the research objectives, the findings, and the limits to this study. Section 5.2 gives recommendations based on the study outcomes.

2. Mine cooling systems overview

Deep-level gold mines require large cooling systems to maintain and/or to achieve an acceptable working environment.



³ Thabiso S. Moropa personal photo: Cooling towers

Chapter 2: Mine cooling systems overview

2.1 Introduction and background

Fridge plants at deep-level gold mines are used to cool down the water that is sent underground or to the BACs. To achieve the desired water temperature, there is a heat transfer at the evaporator circuit (Q_{in}), between the warm water and the refrigerant (R34a, R22, R21, and ammonia) inside the heat exchanger [17].

The refrigeration cycle is illustrated in Figure 2 - 1. The heat transferred from the warm water to the refrigerant plus the energy added by the compressor is then expelled at the condenser circuit (Q_{out}). The heat transfer efficiency of the condenser circuit influences the heat transfer efficiency of the evaporator circuit [18]. The refrigeration cycle occurs in many different forms/configurations at deep-level gold mines, but the concept remains the same.

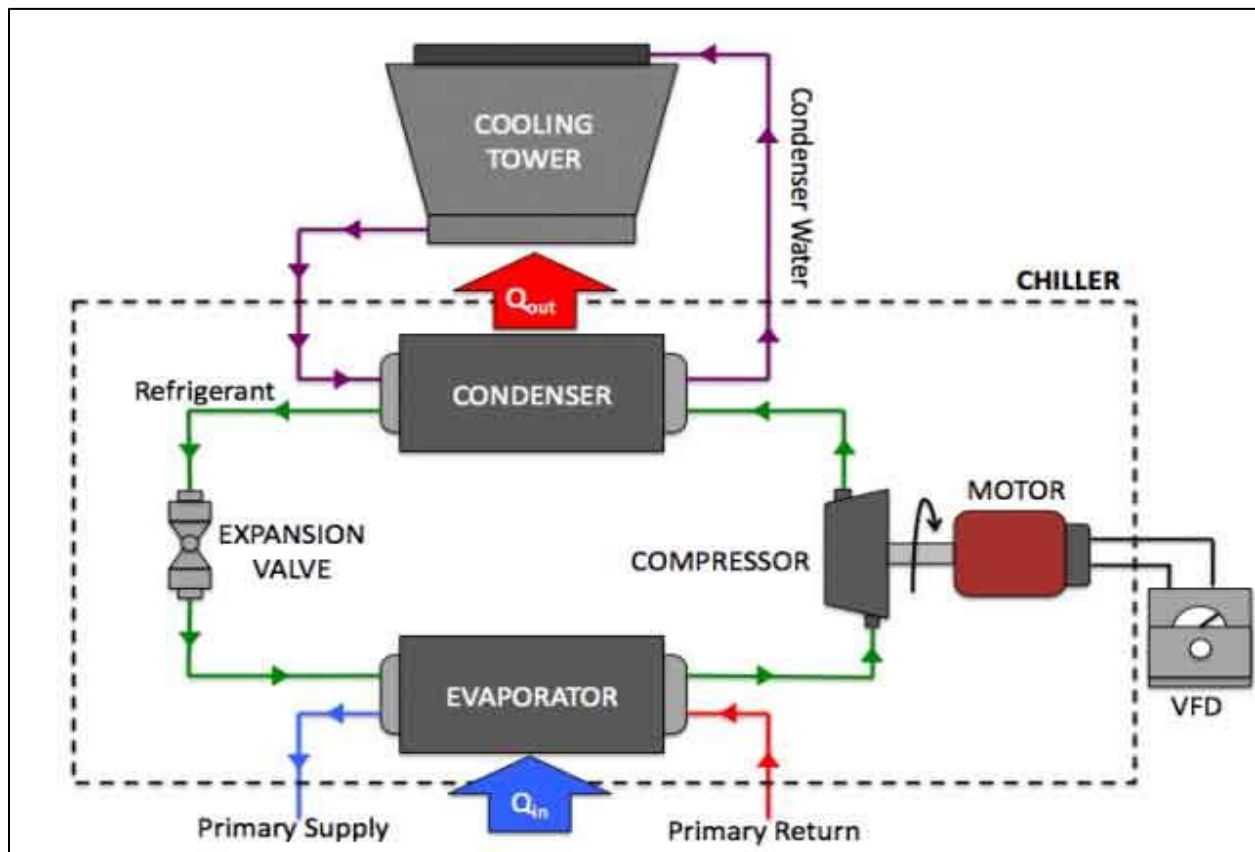

Figure 2 - 1: Typical refrigeration cycle

Ventilation, cooling and the refrigeration systems are key processes within the mine, which uses energy-intensive machinery. Due to the cyclic mining operations and changes in the ambient conditions (temperature and relative humidity (RH)), improved energy efficiencies can be realised. Close to a quarter of electricity consumption of a typical deep-level gold mine is consumed by these large cooling systems [3]. In order to save electricity costs on a mine, energy-intensive operations need to be optimised, inefficient operation components must be replaced, and more energy management strategies must be developed and implemented [19].

The mines' depths are directly proportional to the underground temperatures [20], and as a result, heat stress can be experienced at the deeper mining levels [21]. The reduction of this heat stress requires large cooling systems to produce acceptable working environmental conditions. Various components form part of the mine cooling system. There are several stages which the water has to pass through to reduce the hot temperature and obtain the required temperature. The BACs use some of this cold water as a coolant to cool down the ambient air for ventilation. Figure 2 - 2 shows a typical cooling cycle of water at the deep-level mines. Figure 2 - 2 emphasises what was illustrated in Figure 2 - 1.

Cooling at a gold mine is used for air ventilation, rock drilling, underground machinery, dust suppression, and rock sweeping operations [22]. The large mine refrigeration systems can have a cooling capacity of 30 MW or more [23]. Most of the mine cooling systems are installed on surface and/or underground, and when they are integrated, they are linked to semi-closed loop water reticulation systems. There are several mine cooling system configurations, which will later be explained in Section 2.2.

The fridge plant's compressors, condenser pumps, evaporator pumps, BAC fans, condenser fans and the transfer pumps, contribute towards the electrical energy consumption of the mine surface cooling system [23]. When there are no storage dams in the system and/or no water entering or leaving, the system can be regarded as a closed loop system [23]. Ice-making plants on some mines provide additional cooling [24].

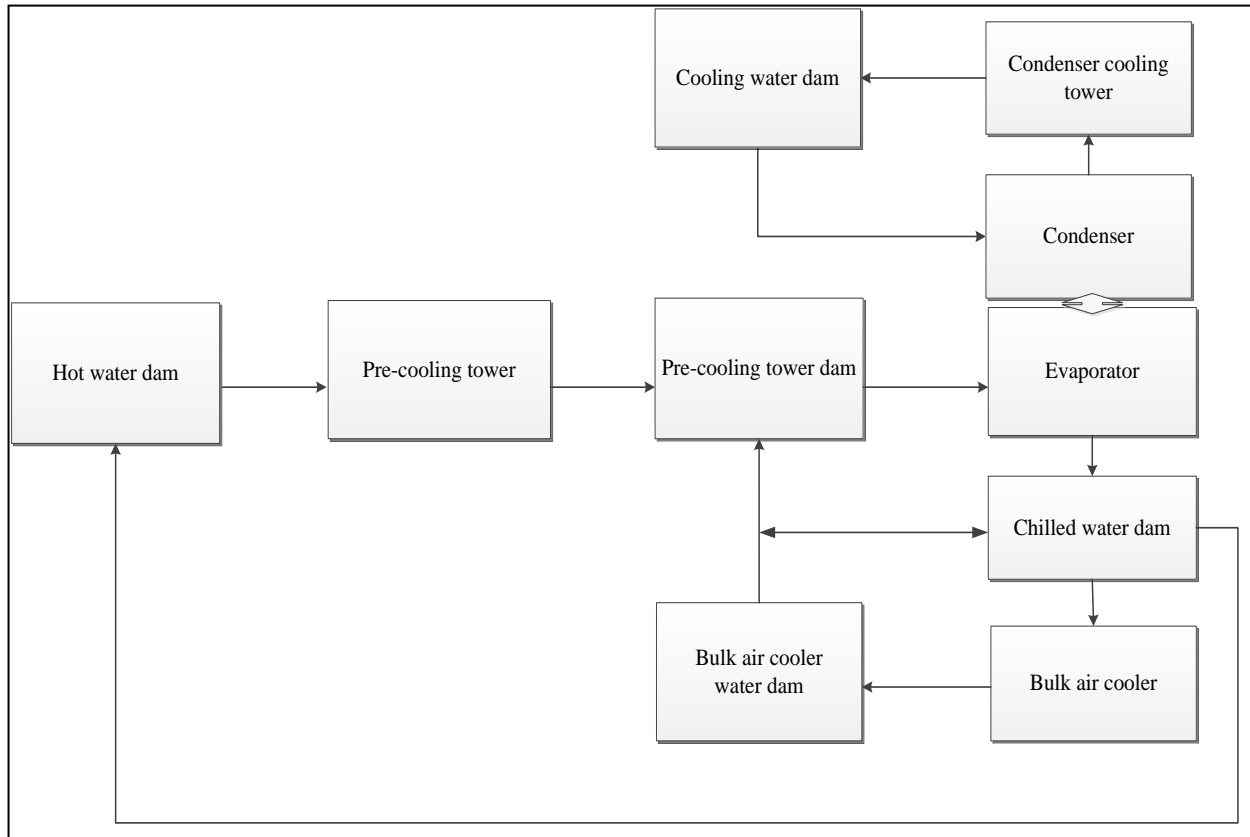

Figure 2 - 2: A generic mine large cooling system flow diagram (adapted from [23])

The cooling demand on the system is dependent on temperature, speed, and RH of the ventilation air, radiation temperature from the virgin rocks, and the atmospheric pressure. The WB temperature and the wind speed are the environmental parameters that mostly affect the cooling power of the cooling system [25].

The specific cooling power of a surface cooling system is dependent on the WB temperature. Figure 2 - 3 shows simulated results that are computed from data of a typical mine; where T_s is the human body surface temperature, P_a is the atmospheric pressure, T_a is the Dry-bulb (DB) temperature, and T_r is the mean radiant temperature of the surroundings. The specific cooling power is shown on the y-axis and the WB temperature on the x-axis. It can be seen that at the lower air WB temperatures, higher cooling power is delivered. In the working areas, the wind speed is generally low, and this increases the cooling demand, thus increasing the cooling power delivered [25].

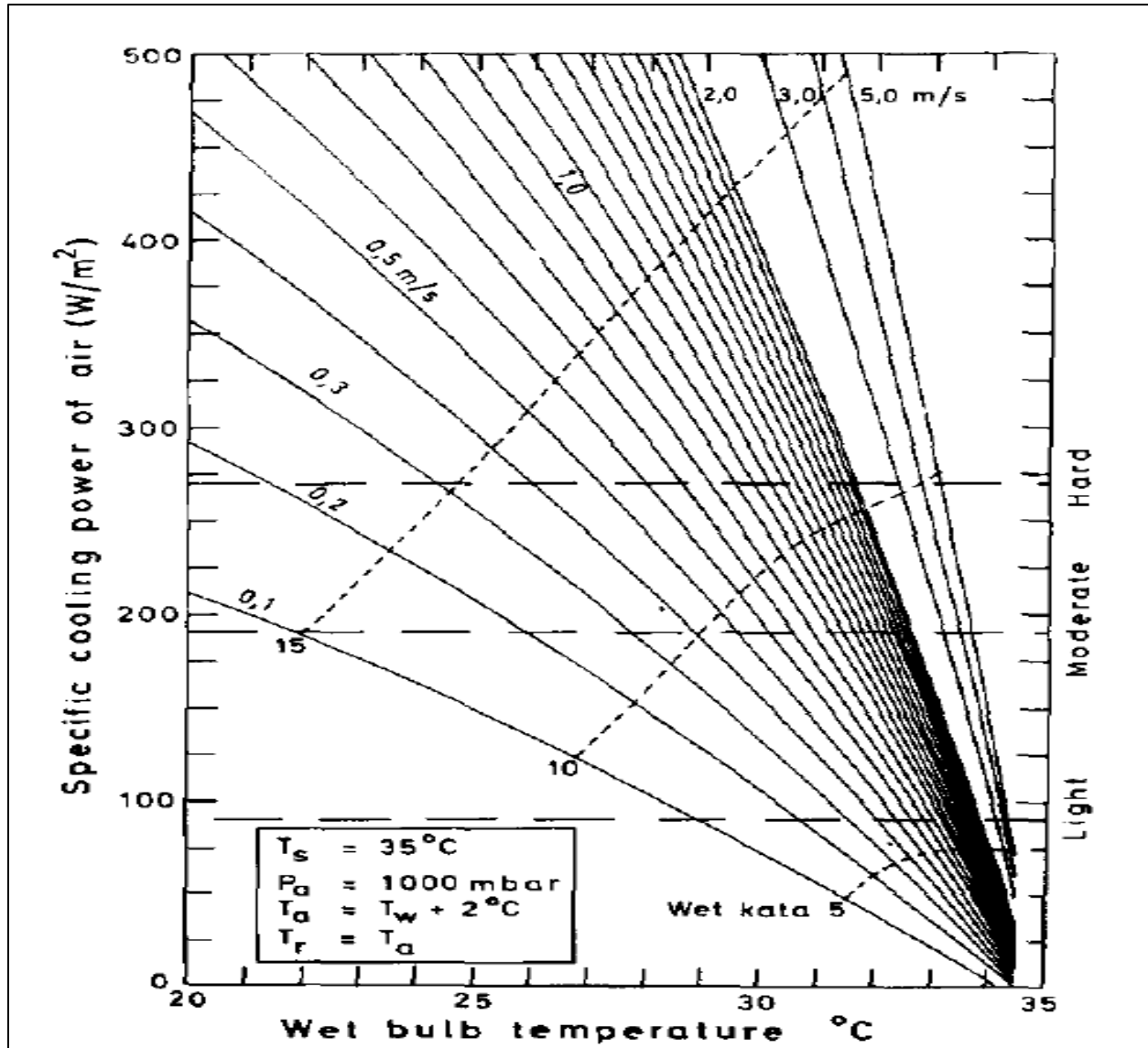

Figure 2 - 3: Specific cooling power: calculated for general use [25]

The VRTs of the common gold mining regions in South Africa are illustrated in Figure 2 - 4. High VRTs are experienced in the deep-level South African gold mines. Air can be re-used for ventilation with VRTs below 35°C. And above 35°C, the air heats up rapidly to over 30°C WB. The VRTs, warm fissure water and the air auto-compression are the main causes of the high underground temperatures [26]. The VRTs are shown on the y-axis and the depth of the mine on the x-axis. It can be seen that the VRTs are directly proportional to the depth of the mines.

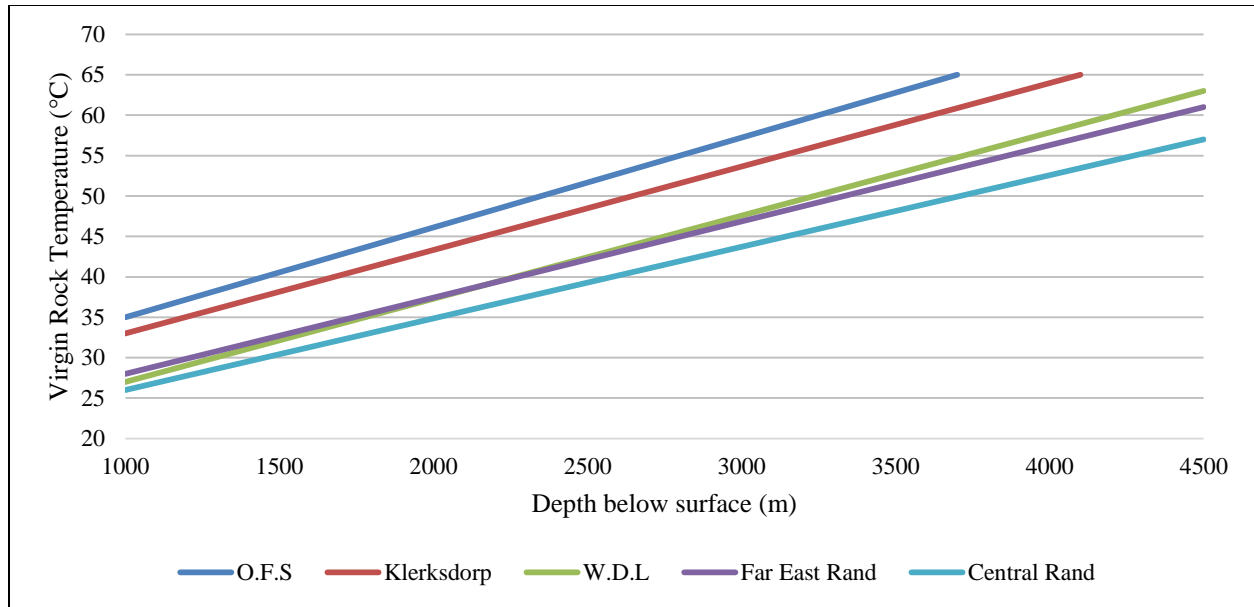

Figure 2 - 4: Geothermic gradient (adapted from [26])

The core temperature of the earth is estimated to be 5 700°C, hence the VRT is one of the main sources of heat in the deep-level mines. The heat from the core flows to the rock surfaces at an average of 0.007 W/m² [27]. During a blasting period, there is an increase in the radiated heat from the blasted reef because of the increased surface area of the rock(s). These high temperatures indicate that there will always be a need for cooling systems while mining.

The theoretical heat load that is imposed by the auto-compression can be calculated using the simplified Equation 1 below [28].

$$q = Q\rho E\Delta d \tag{Equation 1}$$

Where:

- q : auto-compression theoretical heat (kW),
- Q : shaft airflow (m³/s),
- ρ : air density (kg/m³),
- E : energy added per unit distance of elevation (1kJ/102m.kg), and
- Δd : change in elevation (m).

The mine performs ventilation forecasting to determine the cooling demand based on the tonnes produced and the VRTs. The forecasting of refrigeration and ventilation demand in the deep-level and high production gold mines can be challenging because of the cyclic mining operations [26]. The commitments of the mine to certain production targets cause an increase in the mining depths, and hence an increase in the ventilation and cooling demand. Therefore, the installed cooling capacity will also increase to meet the cooling demand [27]. When the ventilation air temperature reaches 31°C WB, is considered used and it has to be ventilated out or cooled again. This hot air is replaced by air with a lower temperature and humidity [26, 28].

The fissure water or the groundwater enters the mining areas at temperature close to that of the VRTs. This water releases heat throughout the mine while it is pumped to surface. The rock face temperature is lowered by the groundwater evaporation [27]. The total heat released from this fissure water can be calculated using Equation 2 [29].

$$q = \dot{m}C_p\Delta T \quad \text{Equation 2}$$

Where:

- q : energy quantity (kW),
- \dot{m} : water flow (kg/s),
- C_p : specific heat capacity (kJ/kg.K), and
- ΔT : change in temperature (K).

The mine cooling systems must operate efficiently as far as possible without affecting the safe working environment. It is crucial to evaluate the efficiency of the refrigeration machines to determine the effectiveness of these cooling systems [30]. The increase in mining depths has led to several developments to meet the cooling demand. Large ice-making machines were installed on the surface and large refrigeration machines were installed underground to meet the cooling demand [31].

As the mining depths increase, the ventilation air and the service water must also be cooled by these refrigeration machines [32]. The refrigeration machines use chilled water and air as cooling agents or as working fluids to cool down the underground working environments.

2.2 Cooling system configurations

Mine cooling systems can be classified by compressed air, water and/or ice refrigeration [30] as illustrated in Figure 2 - 5. These systems can be categorised by surface or underground cooling. Typical mine cooling systems consist of refrigeration plants that produce cold water. This cold water is used to cool the ambient air by direct or indirect contact for underground cooling. This method is still used with the current cooling and ventilation design systems in operational mines. The design will still be applied in future operations [19].

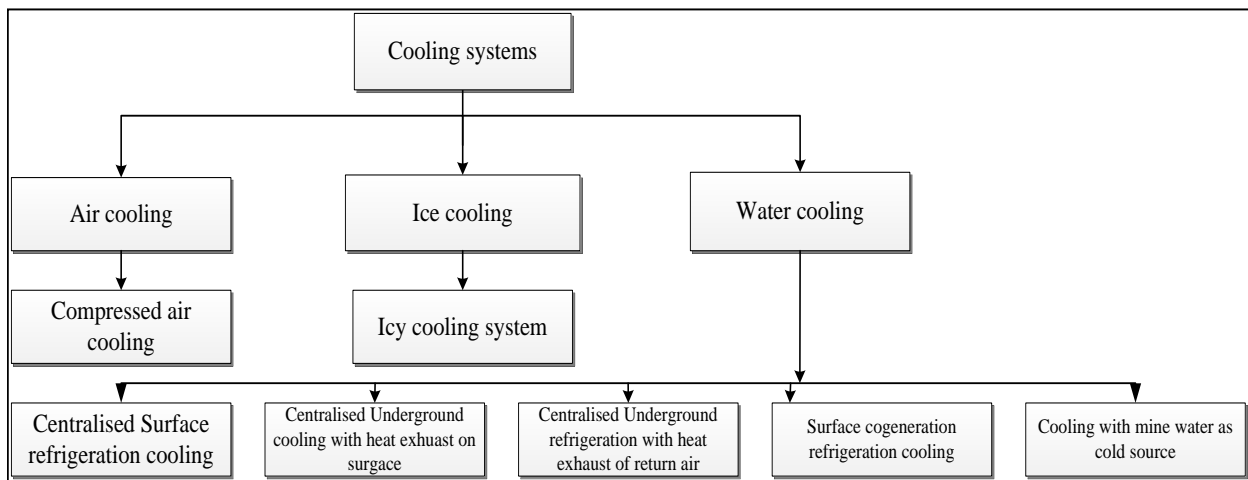

Figure 2 - 5: Mine cooling systems classifications (adapted from [30])

Figure 2 - 6 illustrates an open loop mine surface cooling system. In this system, warm water is transferred to the refrigeration cycle where the heat is transferred to the coolant through heat exchangers. The hot water from underground enters the surface hot dam at approximately 26°C. From the hot dam, the warm water is gravity fed to the pre-cooling towers and pumped to the pre-cool dam through sand filters.

The water temperature in the pre-cool dam is approximately 20°C. On average, about 19 Ml/day of water is pumped from the underground throughout the year [33]. The refrigeration machines are stationed on the surface for convenience of maintenance, and releasing the absorbed heat to ambient surroundings [30].

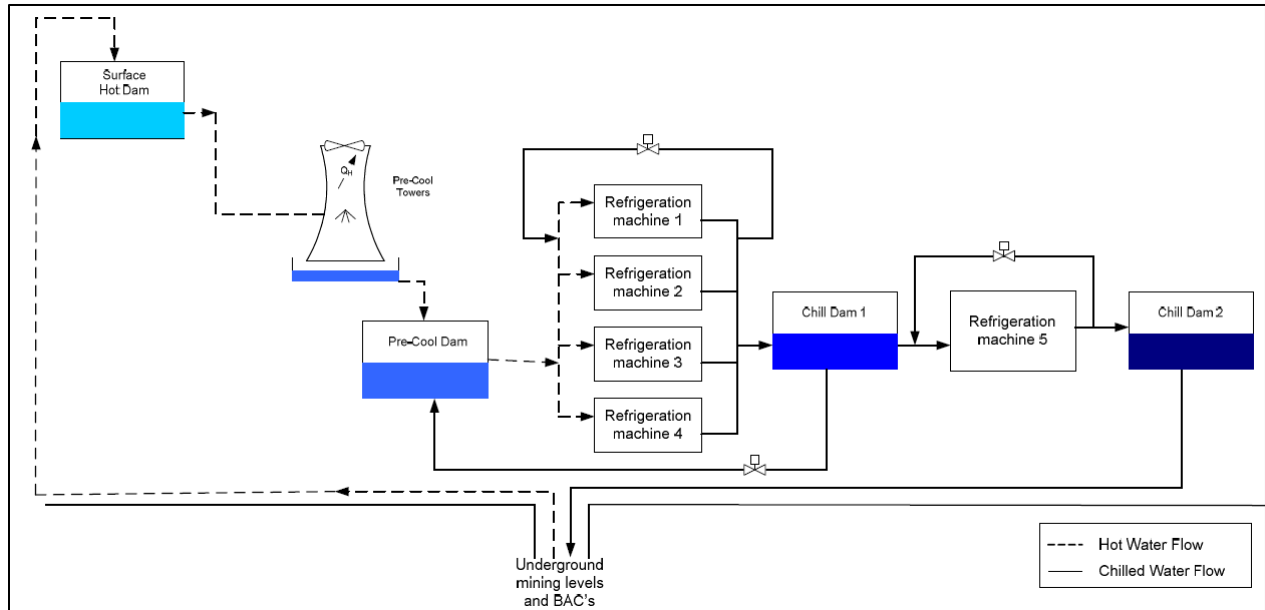

Figure 2 - 6: Open loop mine surface cooling system [34]

Figure 2 - 7 illustrates a platinum mine surface cooling system with a semi-closed loop configuration. The refrigeration cycle is generally the same, what differs is the configuration of the system layout. One of the reasons why the systems differ is the difference in the mining depths. The semi-closed system provides chilled water to a chill dam and to the BACs simultaneously.

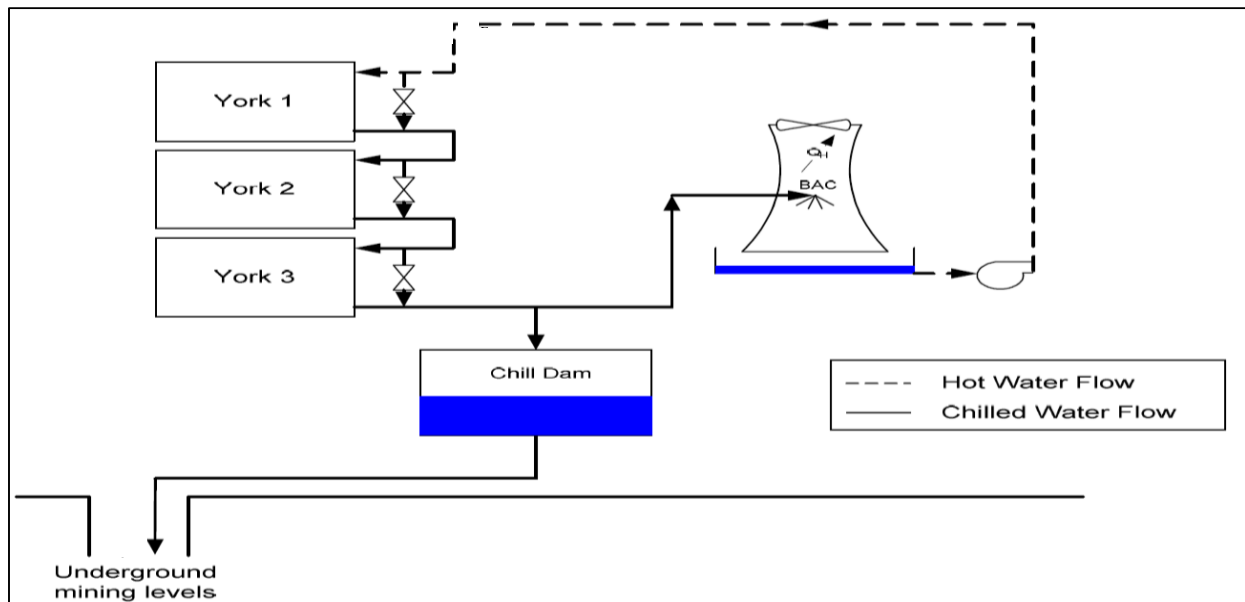

Figure 2 - 7: Semi-closed loop mine surface cooling system [34]

Figure 2 - 8 illustrates a deep-level gold mine surface cooling system with a closed loop configuration. The closed system only provides chilled water to the BACs. This is one of the surface cooling systems that are mostly implemented to supply cooling to the shallow mining levels. They system also consists of energy-intensive infrastructure, making it an ideal system to be investigated for energy management strategies.

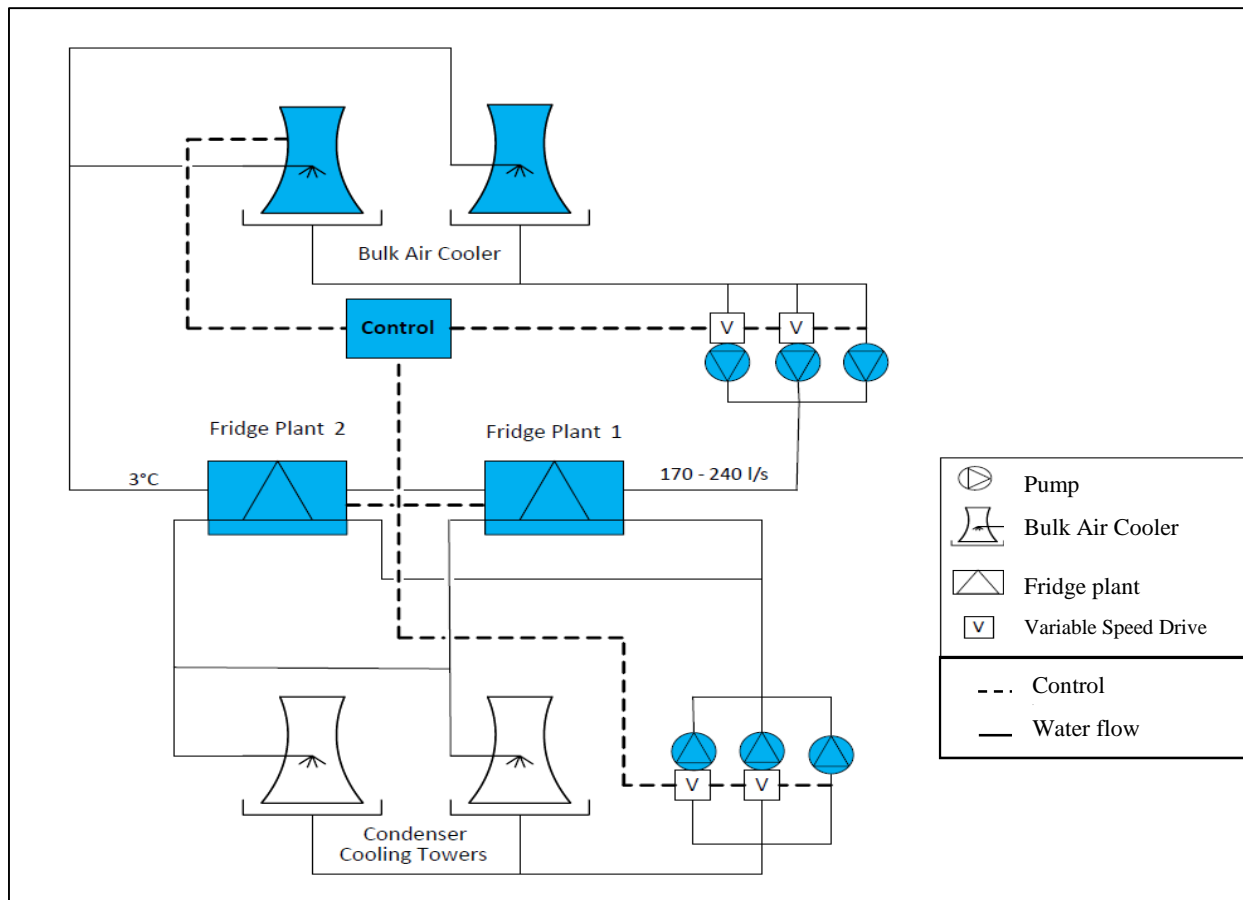

Figure 2 - 8: Closed loop mine surface cooling system [35]

Figure 2 - 9 illustrates an underground cooling system which consists of refrigeration machines placed underground while the cooling towers are on the surface. The placement of these refrigeration machines underground shortens the transfer distances, therefore increasing the cooling capacity [30].

Hot water at 17°C enters the refrigeration circuit and it is pumped to the BACs at 9°C to cool the air that is fed to the working areas. Water from the cooling towers is cooled down from 46°C to 41°C by the return air from the working areas [36, 37].

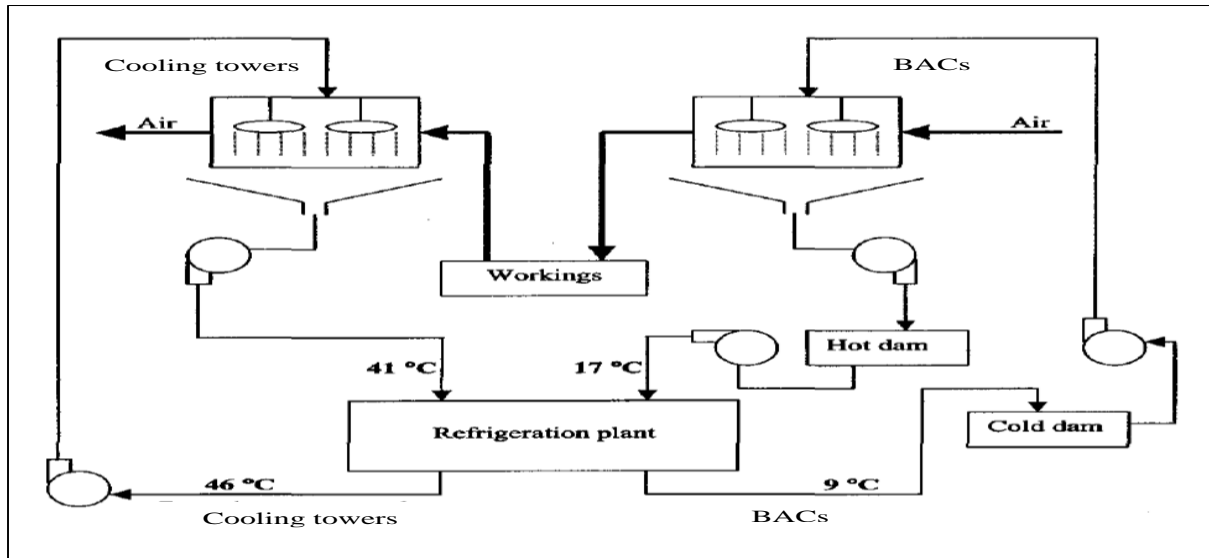

Figure 2 - 9: Underground refrigeration system schematic layout [36]

2.3 Energy cost saving opportunities

The IEA has indicated that DSM is a fast and effective solution to high energy demand concerns [38, 23]. High electrical energy consumption in the mining industry can be managed and reduced by three strategies: load clipping, where the power use is reduced for some period of the day; load shifting, where the electrical energy is shifted to a cheaper and less demanding period of the day; and energy efficiency, where electrical energy usage is reduced permanently [19, 38].

Studies show that electricity costs constitute over 20% of the operational costs of a mine [19]. Up to 40% of electricity is consumed by the ventilation and the cooling of the underground environment [38]. The effectiveness of the EnMSs greatly depends on the type of industry [39]. In this dissertation, the focus is on the deep-level gold mines. It has been indicated in this study that the general application of the DSM for this study is applied to mine cooling systems [40].

The reduction of maximum demand and/or the electrical energy consumption process is referred to as load management. The load management process aims to improve the system to improve on the load factor [41]. Changes to the process equipment and the consumption patterns help with load management.

Load reduction reduces the power consumption of the client by pausing possible operations during the evening peak period. These operations can commence on standard or off-peak periods. Reduction in maximum demand, power loss reduction, better equipment utilisation and cost savings from the expensive peak Tariffs; these are some of the benefits of the load management [41]. The mining industry can take advantage of the incentives and the electricity pricing period to achieve significant savings on operational cost. This can be done without adversely affecting the quality of production or productivity.

The DSM programmes assist power utilities to manage the high electrical energy demand. The DSM programmes can be classified based on pricing: real-time pricing, critical-peak pricing and time-of-use (TOU) Tariffs. This price-based method motivates the industry to use less electrical energy during the expensive peak period. The incentive-based method is whereby a payment is made to clients who are taking part in reducing their load at a requested time [41]. These two methods are illustrated in Figure 2 - 10.

The cost savings from implementing the DSM initiatives depend greatly on TOU. The TOU consists of off-peak, standard and peak. Peak TOU is the most expensive period.

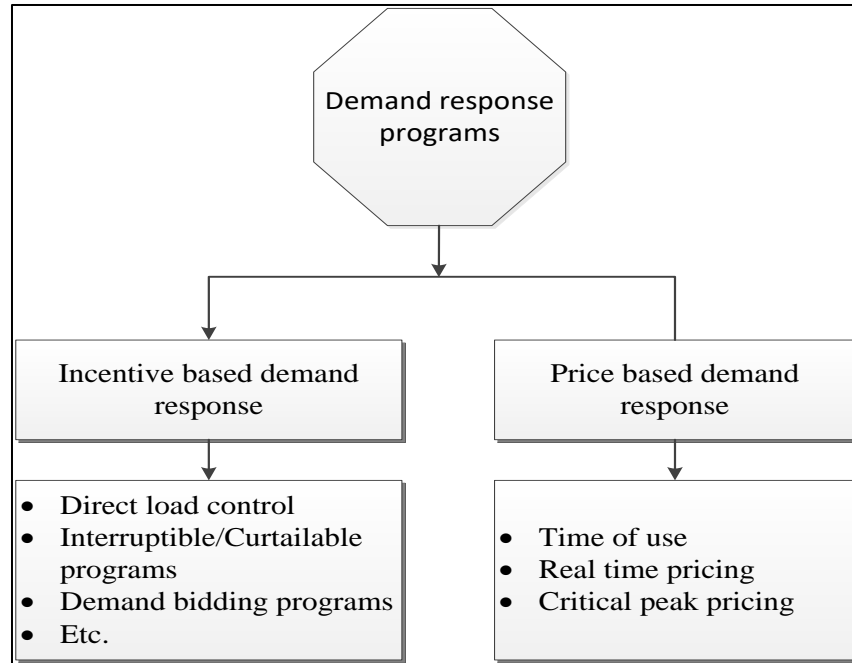

Figure 2 - 10: DSM programmes (adapted from [41]).

Megaflex, Nightsave, Miniflex, and Businessrate are the main TOU Tariff structures Eskom has in place [9]⁴. High energy-intensive industries, including gold mines, are billed according to Megaflex Tariffs. Figure 2 - 11 shows Megaflex Tariff structure TOU during summer season. Winter Megaflex Tariff structure TOU is illustrated in Figure 2 - 12.

Megaflex time-of-use (TOU) period during summer																								
Weekdays	00:00	01:00	02:00	03:00	04:00	05:00	06:00	07:00	08:00	09:00	10:00	11:00	12:00	13:00	14:00	15:00	16:00	17:00	18:00	19:00	20:00	21:00	22:00	23:00
Saturdays	00:00	01:00	02:00	03:00	04:00	05:00	06:00	07:00	08:00	09:00	10:00	11:00	12:00	13:00	14:00	15:00	16:00	17:00	18:00	19:00	20:00	21:00	22:00	23:00
Sundays	00:00	01:00	02:00	03:00	04:00	05:00	06:00	07:00	08:00	09:00	10:00	11:00	12:00	13:00	14:00	15:00	16:00	17:00	18:00	19:00	20:00	21:00	22:00	23:00
	00:00	01:00	02:00	03:00	04:00	05:00	06:00	07:00	08:00	09:00	10:00	11:00	12:00	13:00	14:00	15:00	16:00	17:00	18:00	19:00	20:00	21:00	22:00	23:00
	Off-peak						Standard						Peak											

Figure 2 - 11: Eskom Megaflex Tariff structure for summer – low demand

⁴2016/2017 Eskom Tariffs and charges. Available: <https://www.eskom.co.za/CustomerCare/TariffsAndCharges/>

Megaflex time-of-use (TOU) period during winter																								
Weekdays																								
Saturdays																								
Sundays																								
	00:00	01:00	02:00	03:00	04:00	05:00	06:00	07:00	08:00	09:00	10:00	11:00	12:00	13:00	14:00	15:00	16:00	17:00	18:00	19:00	20:00	21:00	22:00	23:00
	Off-peak						Standard						Peak											

Figure 2 - 12: Eskom Megaflex Tariff structure for winter – high demand

The electrical energy costs before and after implementing the DSM initiative and subsequent saving can be calculated using the following equations [42]:

$$A = \left(\sum_{n=1}^i E_{OP1_n}\right) \times R_{off-peak} + \left(\sum_{n=1}^j E_{S1_n}\right) \times R_{standard} + \left(\sum_{n=1}^k E_{P1_n}\right) \times R_{peak} \quad \text{Equation 3}$$

Where:

- A: Electricity cost per day prior to implementation,
- E_{OP1_n} : Electricity for off-peak TOU hour prior to implementation,
- E_{S1_n} : Electricity for standard TOU hour prior to implementation,
- E_{P1_n} : Electricity for peak TOU hour prior to implementation,
- $R_{off-peak}$: Off-peak Megaflex Tariff,
- $R_{standard}$: Standard Megaflex Tariff,
- R_{peak} : Peak Megaflex Tariff,
- i : Off-peak TOU hours
- j : Standard TOU hours,
- k : Peak TOU hours.

$$B = \left(\sum_{n=1}^i E_{OP2_n}\right) \times R_{off-peak} + \left(\sum_{n=1}^j E_{S2_n}\right) \times R_{standard} + \left(\sum_{n=1}^k E_{P2_n}\right) \times R_{peak} \quad \text{Equation 4}$$

Where:

- B: Electricity cost per day post-implementation,
- E_{OP2_n} : Electricity for off-peak TOU hour post-implementation,
- E_{S2_n} : Electricity for standard TOU hour post-implementation,
- E_{P2_n} : Electricity for peak TOU hour post-implementation,

- $R_{off-peak}$: Off-peak Megaflex Tariff,
 $R_{standard}$: Standard Megaflex Tariff,
 R_{peak} : Peak Megaflex Tariff,
 i : Off-peak TOU hours
 j : Standard TOU hours,
 k : Peak TOU hours.

$$R_{savings} = A - B$$

Equation 5

Where:

- $R_{savings}$: Total electricity cost savings per day (ZAR)

2.4 Previously implemented DSM initiatives

Buy's did a study on the large surface cooling systems of platinum mines [43]. The platinum mine surface cooling system and the proposed infrastructure are illustrated in Figure 2 - 13. The study focused on the surface refrigeration and cooling system of the mines, as well as the underground water reticulation system. The inefficiencies of the cooling and refrigeration system were addressed. Variable Speed Drives (VSDs) were installed as part of the infrastructure to control the water flow rates optimally whilst meeting the cooling demand. Annual electricity cost savings of R12.5 million were achieved without affecting service delivery.

This strategy focused on the energy efficiency on the cooling system throughout the day. It did not consider the underground conditions, but it varies the water flow rates to meet the design set points of the system. There is a need to also to address the high demand during the evening peak periods while monitoring the underground conditions. There also exists a need to implement energy management strategies on closed and semi-closed loop systems because this strategy was implemented on an open loop system.

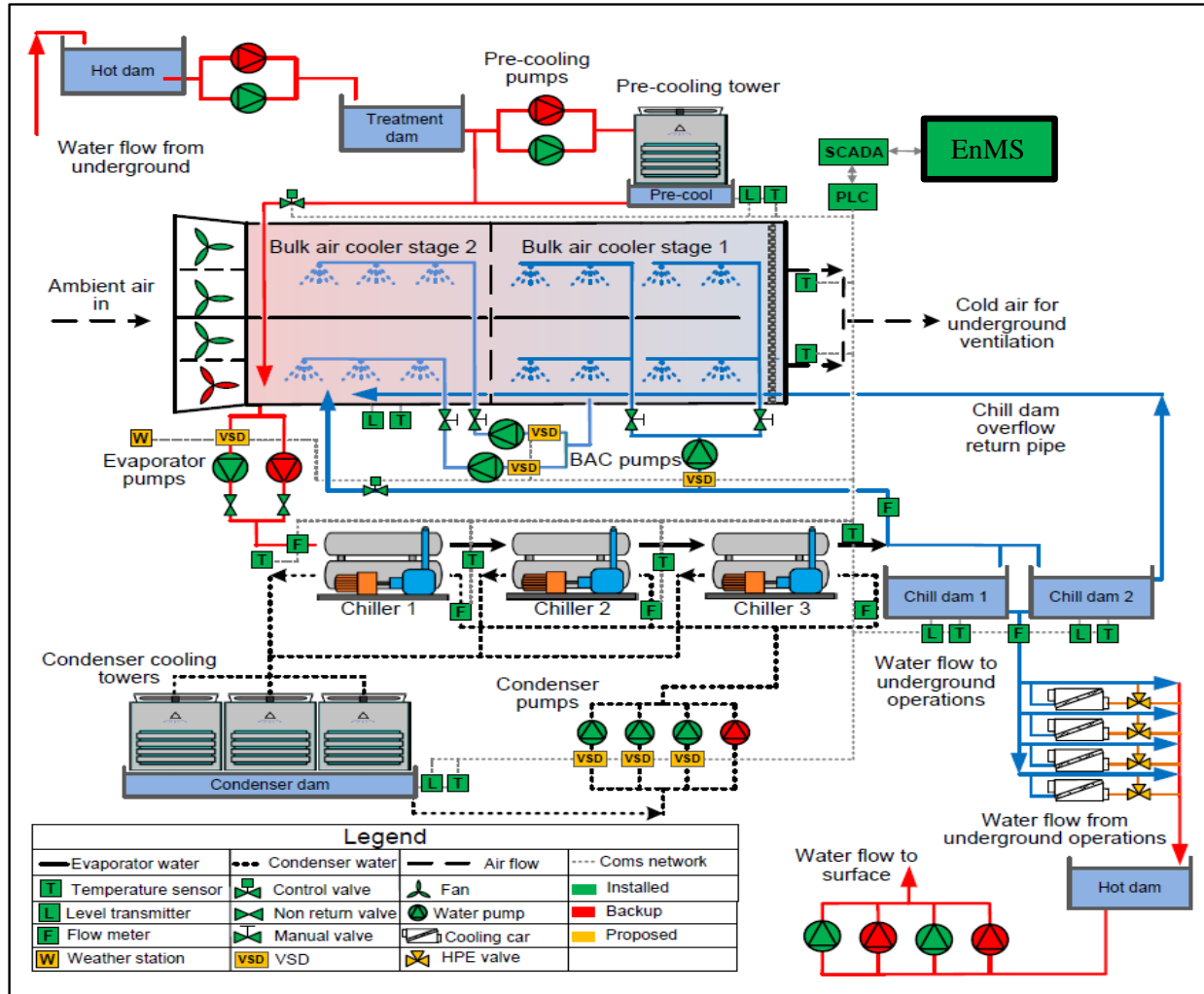

Figure 2 - 13: System layout of the Platinum mine with the proposed infrastructure [43]

Van Greunen [33] did a similar study as Buys [43], but the focus was on a deep-level gold mine. VSDs were installed on all the relevant pumps to optimally control the water flow. The VSDs control the flow, pressure and the automation variables required [33]. The VSDs control the flow according to the design set points; this includes the maximum and minimum flow rates [44]. An EnMS was used to execute the developed strategy [33].

By implementing the strategy, 2.3 MW energy efficiency was realised with daily estimated cost savings of R 23 988 [33]. The system layout for this study is shown in Figure 2 - 14. The communication between the EnMS (here referred to as EMS), the condenser circuit, and the evaporator circuit is illustrated in Figure 2 - 15 and Figure 2 - 16.

Van Greunen’s strategy did not consider the underground conditions either. There is a need to achieve more electricity cost savings on the cooling systems. Closed and semi-closed loop mine surface cooling systems should also be addressed, whereas this strategy is also based on an open loop system. The use of VSDs on the system to achieve energy efficiency should be maintained.

Van Greunen made use of EnMS to aid in executing the strategy. A similar EnMS can be used for most of the energy management strategies on the mine cooling systems. The same procedure illustrated in Figure 2 - 15 and Figure 2 - 16 can be applied to other studies that are based on the deep-level mine cooling systems.

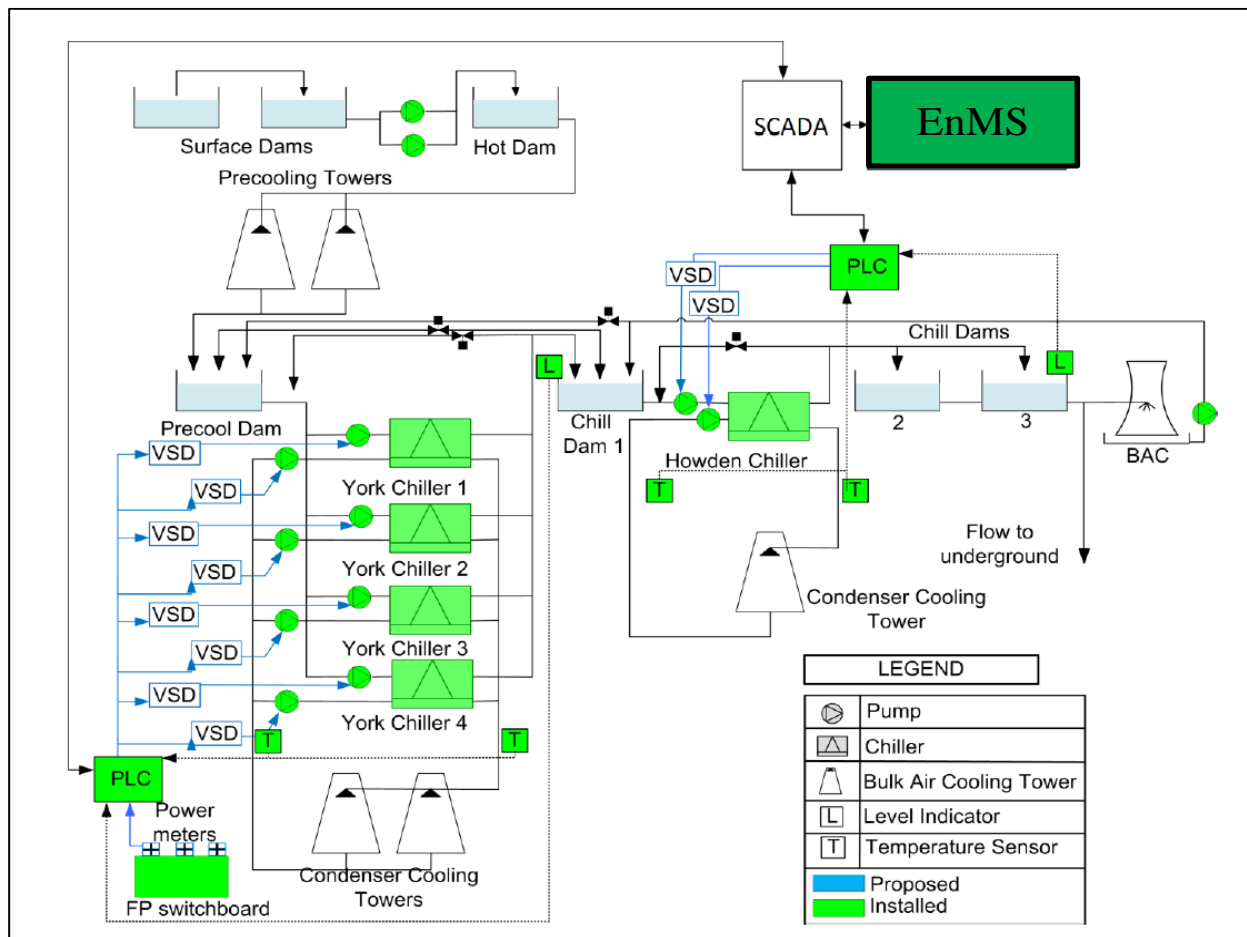

Figure 2 - 14: Open loop surface cooling system [33]

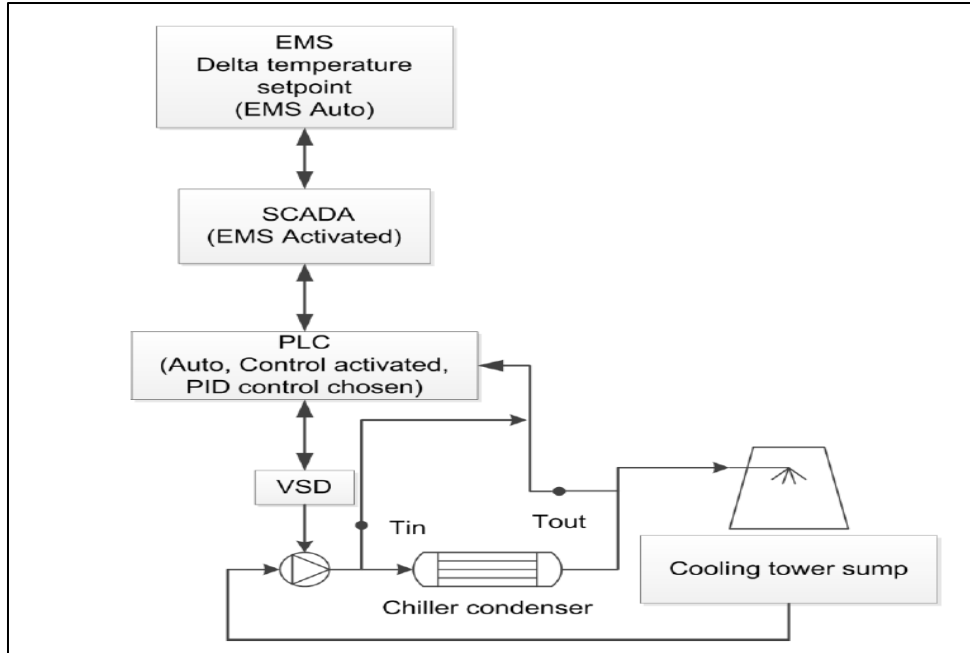

Figure 2 - 15: Water flow control – Condenser [33]

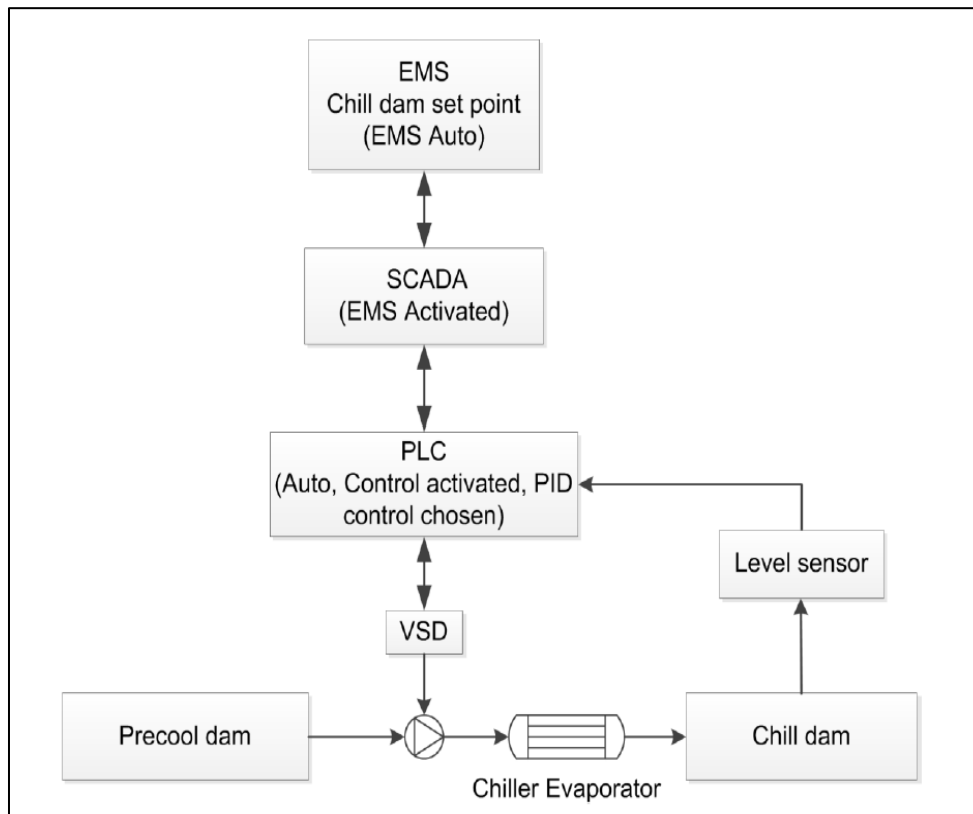

Figure 2 - 16: Water flow control - Evaporator [37]

Uys developed an approach that involved converting an ice storage system to a chilled water system, which entails varying of the water flowrates through the system [45]. Uys also made use of the VSDs to vary the water flow rate through the system. This conversion resulted in an additional chiller to be used as a backup while sufficiently meeting the cooling demand. After implementation, a saving of 1.5 MW was achieved. Figure 2 - 17 shows the system with the ice storage that was decommissioned and converted to a water chiller.

Uys’s strategy is very expensive to implement, hence a longer payback period. When this strategy was implemented, Eskom funds for the DSM projects were still sufficient to buy expensive infrastructure. The current funds for these DSM projects have greatly been reduced, as a result, the new strategies need to be cost effective while achieving electricity cost and energy savings. Therefore, a strategy needs to be developed to achieve these savings in a cost effective manner. The underground working conditions should also be taken into account when the cooling system is being improved to achieve these savings.

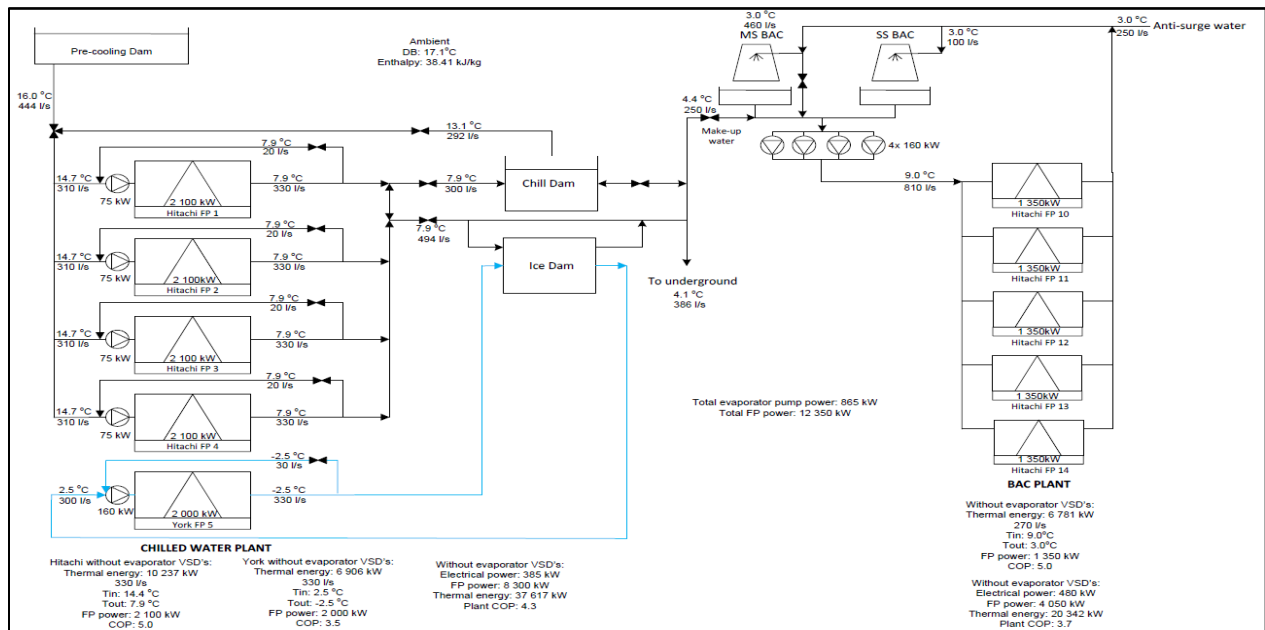

Figure 2 - 17: Surface cooling system layout [45]

Holman’s study focused on monitoring the performance of the mine cooling system components [46]. Maintenance schedules and operational procedures were evaluated. By improving the maintenance schedules of the refrigeration machines, 52 GWh can be achieved annually with the cost savings close to R900 000 [46]. Performance of the components and maintenance schedules that were evaluated are shown in Figure 2 - 18.

The improved maintenance schedules can be used to aid in achieving more electricity cost savings during the evening peak period. This is because most of the maintenance can be scheduled to take place during the evening peak period, thus achieving load reduction on the system. These schedules are implemented without adversely affecting the labour cost, hence incorporating the schedules with the load management strategies can be beneficial to the mine because of the reduced operational costs (electricity costs).

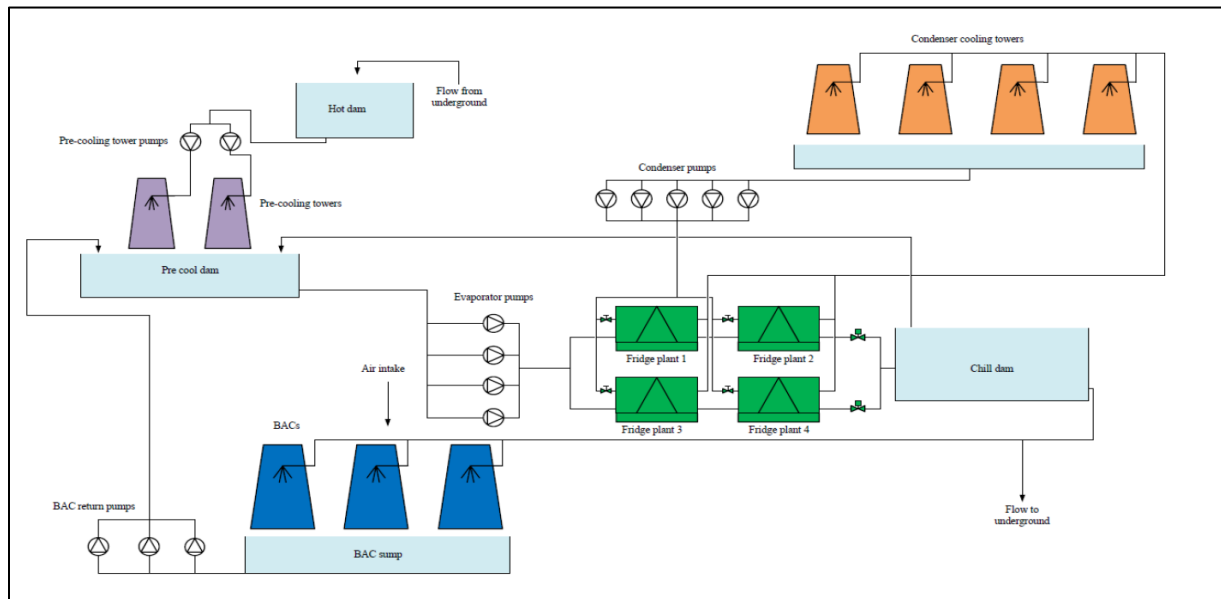

Figure 2 - 18: Mine cooling system layout under investigation [46]

Schutte did a quantitative analysis on the whole mine cooling and ventilation systems [27]. The analysis involved the development of a load management strategy. In addition to the load management strategy, a peak clip on the surface BACs was achieved. Implementation of the peak clip realised annual cost savings of R1.4 million. The combination of all the strategies on

the entire mine cooling and ventilation systems: load management, energy efficiency and peak clip; annual estimated cost savings of R30 million were achieved.

These savings constitutes 38% of the mine cooling and ventilation systems costs and 16% of the total mine electricity costs [27]. Figure 2 - 19 illustrates the mine’s entire cooling and ventilation systems where the three strategies – load management, energy efficiency, and peak clip – were implemented.

Schutte’s study addressed semi-closed and open loop mine cooling systems. The fundamentals that were applied to develop the strategy for this study can be applied to closed loop systems as well. The study thoroughly explains the load management and energy efficiency strategies that can be implemented on mine cooling systems. These strategies can be improved by incorporating the underground working conditions, i.e. temperature and relative humidity. These improvements can also be applicable to close loop surface cooling systems.

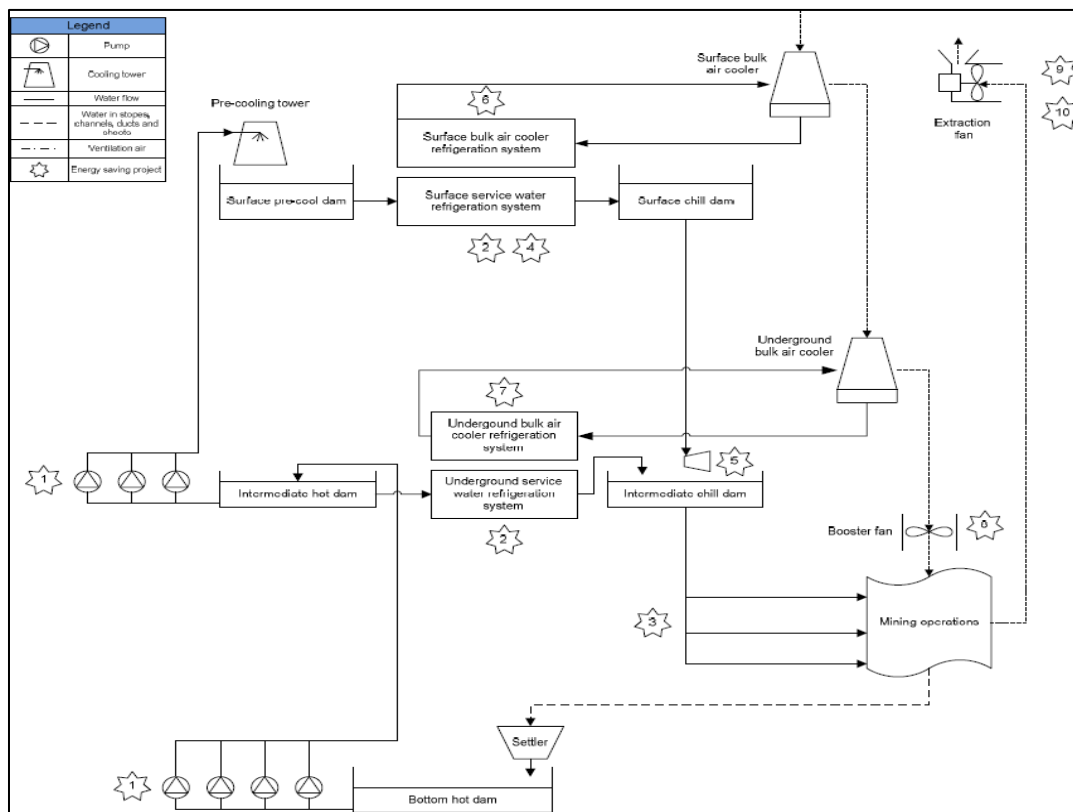

Figure 2 - 19: Integration of cooling and ventilation systems for a typical deep-level gold mine [27]

Du Plessis et al, did an energy audit on 20 of the South African mine cooling systems [3]. Energy and greenhouse gas emission savings were estimated. The energy audit showed that there is an annual potential to save approximately 144 721 MWh on the 20 mines, which makes up a 32.2% saving on the cooling systems electricity costs. VSDs were implemented on one of the deep-level gold mines as a case study. This study resulted in 29.9% electricity costs savings [3].

Energy efficiency strategy was developed for another deep-level gold mine. This strategy varies the water flow rates through the use of VSDs. For this system, an average of 7% savings on the cooling system electricity costs was realised [47].

Du Plessis further developed a hierarchical controller, which uses an EnMS for execution [23]. This controller automatically controls, optimises, monitors and reports on the variable flow strategies. Four deep-level mine cooling systems were used for implementations. The controller integrates the mine SCADA, the EnMS and the field equipment. This controller proposes improved running schedules of the cooling equipment to achieve energy efficiency. On all four cooling systems, an average of 33.3% electricity cost savings were achieved [23]. The generic controllers of the case studies are illustrated in Figure 2 - 20.

The generic controllers illustrated in Figure 2 - 20 form part of the EnMSs that are mostly used in mine cooling systems. Most of the DSM developed strategies on the deep-level gold mines require EnMS for execution, especially with the automatic control strategies. These generic controllers can be adjusted from system to system and be implemented successfully.

Du Plessis's study mainly focused on the use of VSDs to achieve energy efficiency on the mine cooling systems. The study did also not consider the underground working conditions but to maintain the cooling systems at their design specification. Further studies can be conducted to develop strategies that will look into the underground temperatures and relative humidity. The generic controllers developed by du Plessis can be used to executive these future strategies successfully and sustainably.

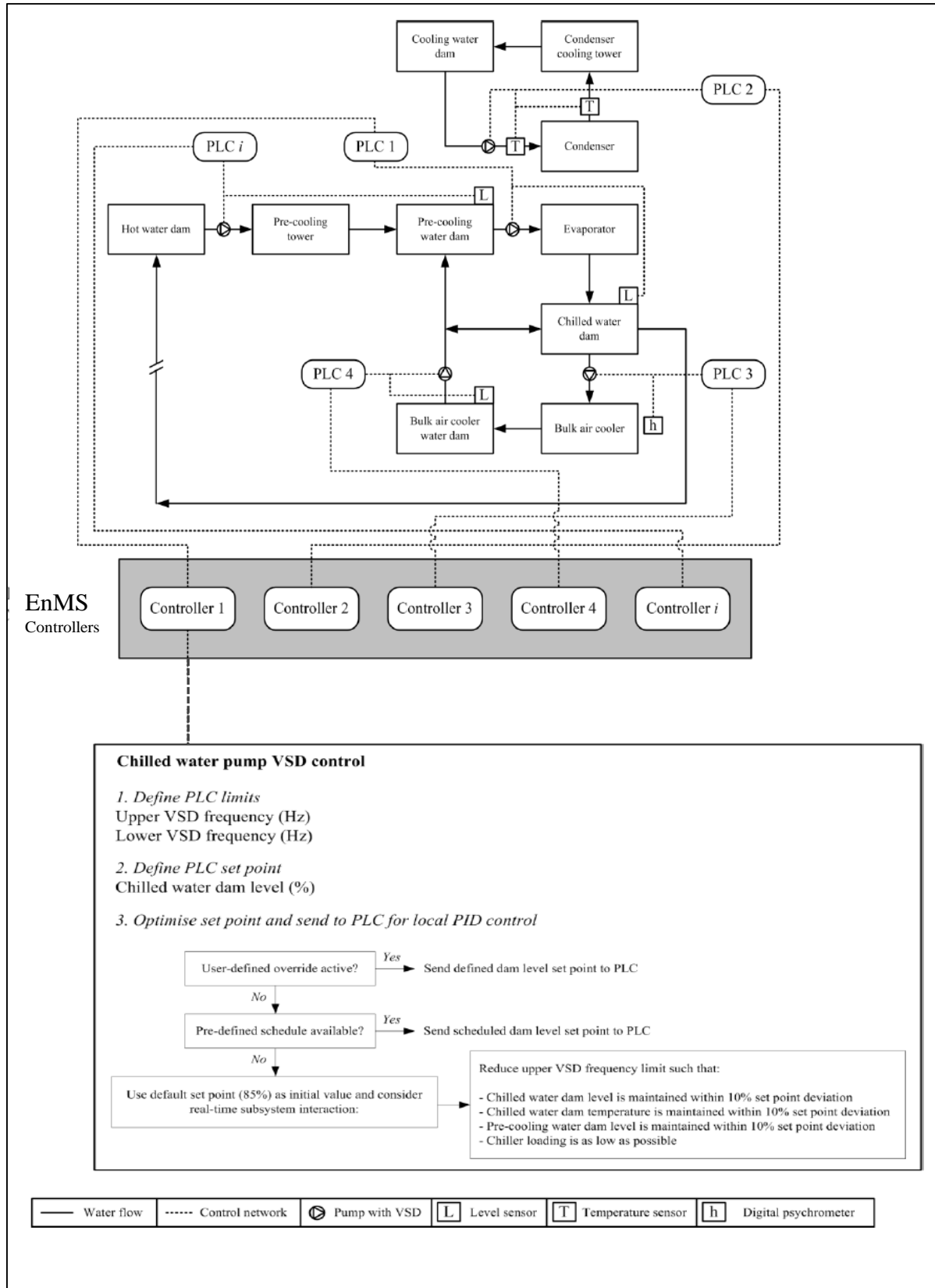

Figure 2 - 20: The EnMS generic controllers integrated with VSDs control

Other DSM initiatives:

Vosloo simulated a strategy that can be implemented on gold and platinum rock winder systems [48]. A deep-level gold mine was used as a case study to implement the strategy. An evening load shift of 9.5 MW, and electricity cost savings of R1.3 million, was achieved. Buthelezi did a similar study on rock winders of one of the deep-level gold mines in South Africa [49]. The system was automated and controlled using the developed strategy. An average of 2.4 MW was achieved with annual cost savings of R300 000 after implementation. Bosman's strategy achieved annual electricity cost saving of R200 000 [50].

Vosloo also developed a model to minimise the operating cost of the water reticulation systems on deep mines [51]. The techniques that were developed were implemented on two case studies. The average load of 2.3 MW was achieved with annual electricity cost savings of R3 million. Richter did a comparison between automated and manual pumping DSM projects [52]. There was a 40% improvement when the pumping system was automated, resulting in approximately 45% in electricity cost savings.

Van Heerden developed a technique that can dynamically control the pressure set points of compressors at deep-level mines [53]. The technique achieved an average of 1.8 MW with electricity cost savings of R3.7 million. Spangenberg did an analysis on the effect of the DSM projects at the South African cement factories [54]. The analysis concluded that the DSM projects on the cement factories are sustainable. Groenewald came with a new performance-centred maintenance strategy that can be implemented to maintain the DSM projects for more than 60 months [55]. The electricity cost savings of the DSM projects where the strategy was implemented increased by an average of 64.4%

Table 2 - 1 shows a comparison of different DSM projects/strategies that are implemented at different deep-level mines. Most of the studies as explained above form part of the list shown in Table 2 - 1. It can clearly be seen that most of these DSM projects are over-performing. The surface cooling auxiliaries, however, are the least performing. This is an indication that the mine surface cooling systems need to be utilised more effectively to increase performance and achieve improved cost savings.

Table 2 - 1: DSM projects – daily performance overview [55]

Maintenance agreement									
Client 1		Performance	Cost saving	Control	Auto	OPC	Agent	E-mail	
Site 1	cooling auxiliaries surface	32%	R 1,374	100%	98%	98%	100%	100%	
Site 1	cooling auxiliaries underground	197%	R 26,457	-	-	-	-	-	
Site 1	water supply optimisation	110%	R 16,708	100%	97%	97%	100%	100%	
Site 2	cooling auxiliaries	319%	R 54,637	100%	98%	15%	100%	100%	
Site 2	optimisation of air networks	408%	R 67,146	100%	95%	69%	100%	100%	
Site 2	pumping system	121%	R 4,928	100%	98%	47%	100%	100%	
Client 2		Performance	Cost saving	REMS	Auto	OPC	Agent	Hermes	
Site 1	4# pumping system	93%	R 1,390	100%	71%	94%	99%	100%	
Site 1	optimisation of air networks	283%	R 48,842	100%	98%	98%	100%	100%	
Site 2	optimisation of air networks	127%	R 26,202	100%	99%	99%	100%	100%	
Site 3	pumping system	85%	R 2,299	100%	98%	97%	100%	100%	
Site 4	optimisation of air networks	110%	R 17,986	100%	97%	42%	98%	100%	
Site 4	pumping system	79%	R 3,508	100%	99%	99%	100%	100%	
Client 3		Performance	Cost saving	REMS	Auto	OPC	Agent	Hermes	
Site 1	pumping system	106%	R 8,629	100%	98%	98%	100%	100%	

Many DSM strategies are implemented on other mine energy-intensive systems such as rock winders, compressors, dewatering and water reticulation systems, but few on surface cooling systems. The few surface cooling systems with DSM initiatives do not consider the underground conditions. Therefore there is a need to develop a strategy which will incorporate the underground working conditions and improve performance.

2.5 Conclusion

The need for underground cooling on the deep-level gold mines remains crucial. Depending on the depth and the environmental conditions of the mine, each mine has a unique cooling system configuration. These large cooling systems are energy-intensive and energy saving measures need to be applied. The fundamentals of the energy saving strategies that were previously implemented on the cooling systems form the background to this study.

Several DSM initiatives were implemented on the large cooling systems. Most of these initiatives focused on installing the VSDs to vary the water flow rates to meet the cooling demand. In most cases, the DSM initiatives were implemented on open loop surface cooling systems.

There is a need to develop a versatile strategy that can be applied to closed and semi-closed loop systems. This strategy should take into consideration the monitoring of the underground conditions, i.e. underground temperatures and relative humidity.

3. Strategy development to achieve cost savings on mine surface cooling systems

This chapter focuses on the development of a load management strategy. The strategy will be applicable to closed and/or semi-closed loop mine surface cooling systems.



Chapter 3

⁵ Thabiso S. Moropa personal photo. Bulk air cooler fans of a deep-level gold mine

Chapter 3: 1. Strategy development to achieve cost savings on mine surface cooling systems

3.1 Introduction

Chapter 1 elaborated on the problems that the national power utility, Eskom, is facing with the high electricity demand. Eskom aims to manage this high demand with the DSM programme, as explained in Chapter 2. Thus far, various DSM initiatives have been implemented on different sectors of the industry, including deep-level gold mines.

Most DSM initiatives are implemented on the mine cooling systems (surface and underground). With the increasing electricity demand and shortage of generating capacities, the need for energy efficiency and load management remain crucial. Electricity Tariffs are increasing faster than the inflation rate; hence the energy-intensive sectors are keen to achieve cost and energy savings to reduce operational costs.

The previous DSM initiatives implemented on the mine cooling systems form the backbone of this study. To further optimise the system it is necessary in order to achieve more electricity cost savings on the systems with the existing DSM initiative(s). This chapter looks at improving the running schedules of the surface cooling system and the verification of the strategy.

3.2 Developing a new operating strategy

This section presents the methodology to achieve load reduction on the mine surface cooling systems during the evening peak period (18:00 – 20:00 in summer and 17:00 – 19:00 in winter). The aim of this study is to shift the electricity consumption of the mine surface cooling system out of the expensive Eskom evening peak period. This is done through developing optimal running schedules for the cooling system. These optimal running schedules will be executed by the control room operators on site on a daily basis.

Closed and semi-closed loop mine surface cooling systems have similar configurations, as discussed in Chapter 2. The strategy should be versatile for both systems (closed and semi-closed loop). The first step is to conduct an investigation on the specific site at hand.

On each system mentioned above, the existing DSM initiative(s) must be identified and evaluated. The evaluation of the system involves the performance of the existing DSM initiative(s). The performance of the initiative(s) must prove to be sustainable.

And as mentioned previously, the electricity Tariffs are increasing faster the inflation rate; this means more potential and feasible DSM initiatives must be identified and implemented to reduce operating costs. Figure 3 - 1 illustrates the first steps to be followed when conducting the investigation(s) on the deep-level gold mines.

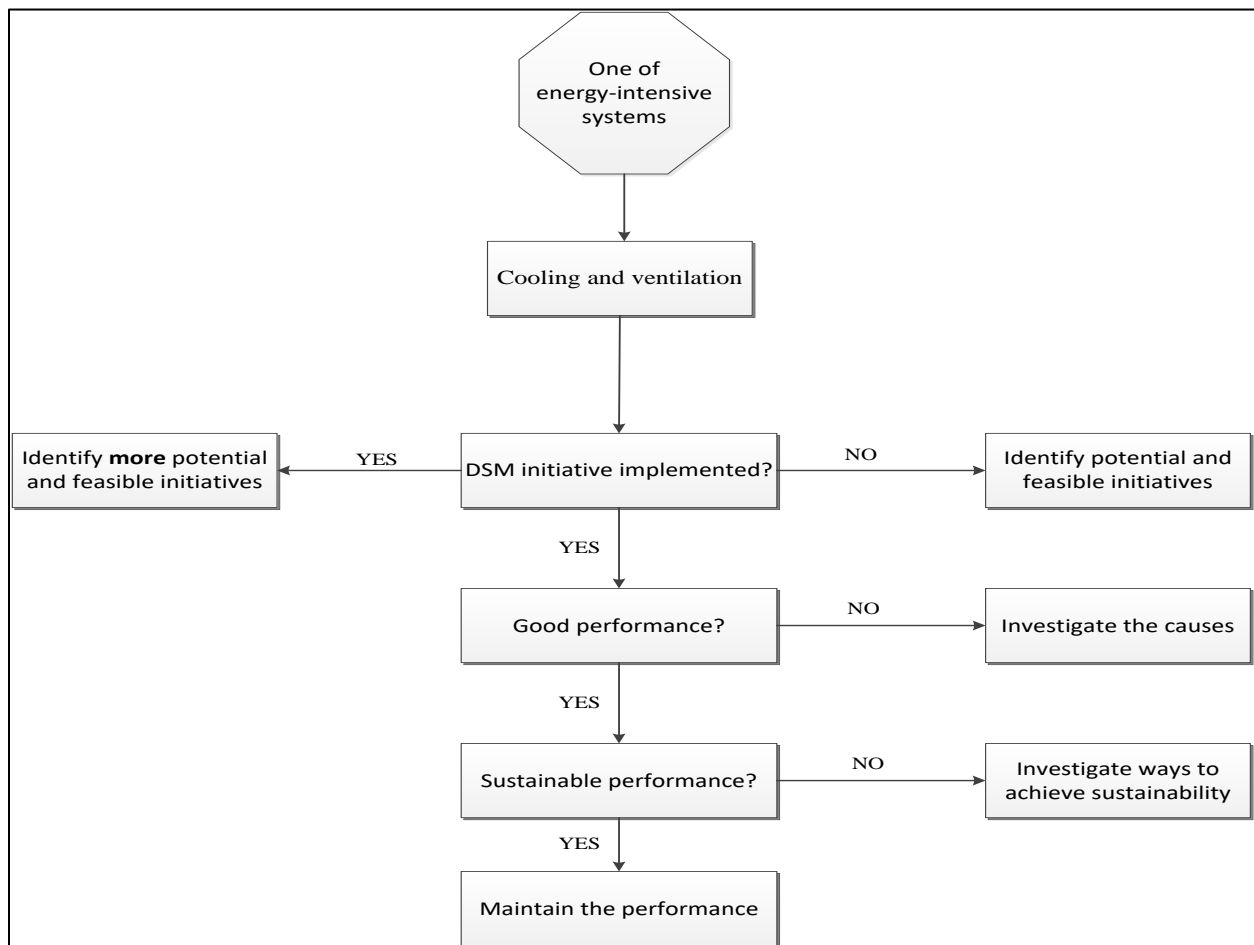

Figure 3 - 1: Deep-level gold mines investigation methodology flow chart

It was mentioned in Chapter 2 that the cooling system consumes approximately 25% of the total electricity consumption of the mine. The main objective of this study is to achieve more electricity cost savings on the mine surface cooling system by implementing DSM initiative(s). As a result, strategy for this study will focus on the mine surface cooling systems of different configurations: close and semi-closed loop systems.

The mine surface cooling system is chosen because of the favourable evening temperatures that reduce the cooling demand. The evening peak period is a blasting period at most of the gold mines. During blasting, no mine workers (other workers can still go down) are allowed to be underground, and this in turn reduces the cooling requirement underground. These are some of the reasons that make the surface cooling system a potential system to implement more DSM initiatives.

Figure 3 - 2 illustrates the methodology that can be followed on the mine surface cooling system with a closed loop configuration. What is important with the system analysis is data availability. Power and process data loggers must be in place. The logged data is used to compile the normal operation baseline, i.e. power and process variables baselines. These baselines are important as they are used to determine the impact of the strategy on the system.

The surface cooling systems are designed to have an impact up to the inlet of the underground BACs. Therefore, it is important to measure the underground conditions such as temperatures and RH of the designated areas that are cooled down by the surface cooling system. To measure these conditions, temperature and RH sensors must be in place. If no sensors are available, they must be installed.

Load reduction tests must be conducted to verify if it is possible to switch off the surface cooling system without affecting the underground conditions. Due to a number of uncertainties, no mine workers are allowed underground during these tests. There are some weekends at the mines when there is no production; these weekends are used to conduct the load reduction tests. In the evening peak period, the fridge plants, evaporator pumps, condenser pumps, BAC fans, and

condenser cooling fans can be switched off if the underground temperatures are below 25.5°C WB (maximum limit). The operating limits will be explained at a later stage.

If the underground temperatures during the evening peak period reach the maximum temperature limit (25.5°C WB), additional fridge plant with its auxiliary equipment must be switched on to meet the cooling demand. This means that the measured temperatures and RH must be closely monitored during the test. If the measured underground conditions remained within the normal operation ranges or below the 25.5°C WB limit, the tests can be considered successful. The success of the tests will give a green light to implement the strategy. The strategy will be validated over a period of three months after implementation.

EnMS will be utilised to propose the optimal running schedules of the surface cooling system. All the power and process variables data will be logged on the EnMS, including the underground environment conditions. The control room operators will be given full training of the EnMS in order to achieve sustainable cost savings. The control room operators will manually monitor the underground conditions from the installed sensors and switch off the fridge plants with auxiliaries when the underground temperatures are below 25.5°C WB.

The training of the control room operators compliments the load management strategy. A phone call reminder will be made to the control room to remind the operators to switch off the surface cooling system equipment. This phone call will serve as an additional reminder to the control room operators in order for the strategy to achieve sustainable savings.

The mine with a semi-closed loop surface cooling system configuration can follow the same methodology used for closed loop configuration. However, the sub-systems that receive cold water from the surface cooling system must be taken into consideration. These sub-systems can either be soft and hard ice plants and/or surface storage dam capacity. Usually these sub-systems consume approximately 20% of the total surface cooling system generated capacity.

In cases where there are sub-systems, the mine(s) would have an additional source of cooling. The cold water that would have been supplied by the surface cooling system can be supplied by

the additional source during the evening peak period. If there is no additional source, the circulating pumps must continue circulating the water through the system to the BACs.

This circulated water would still have an effect on the outlet temperature of the BACs before the water gets warm due to the frictions in the system. The water temperature must be also monitored because higher temperatures would affect the sub-systems negatively. The closed and semi-closed loop system methodologies are illustrated in Figure 3 - 2 and Figure 3 - 3 respectively.

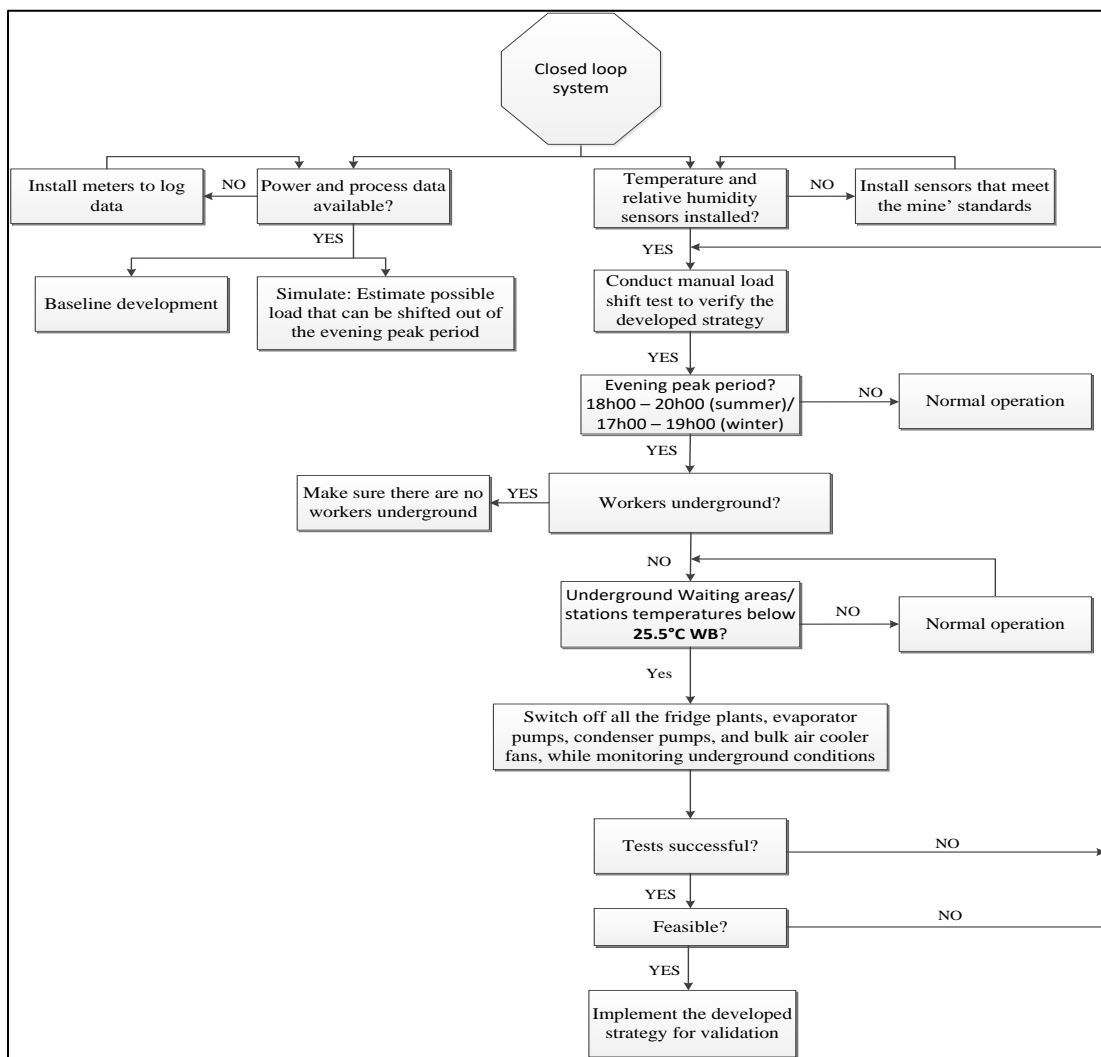

Figure 3 - 2: Methodology that can be followed with a closed loop mine surface cooling system

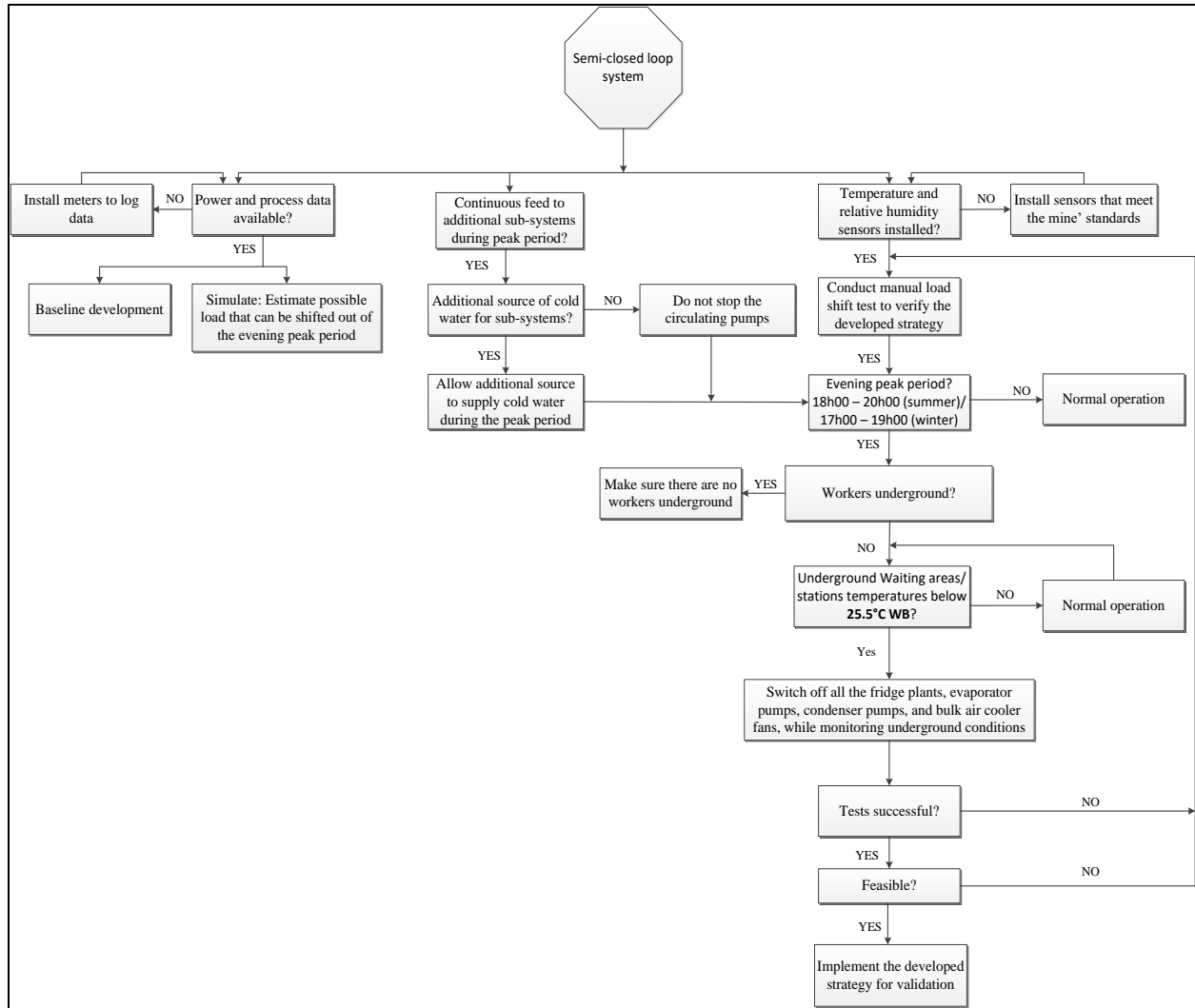

Figure 3 - 3: Methodology that can be followed with a semi-closed loop mine surface cooling system

The testing and implementation of the load management strategy must not affect the safe underground working conditions. Therefore it is important to have process variables, set points, and process control constraints to maintain the existing cooling supply and/or to continue meeting the cooling demand.

The surface fridge plants with its auxiliaries i.e. the evaporator pumps, the condenser pumps, the BAC fans and the condenser fans form part of the scope of this study. Monitoring of the underground environmental conditions forms the core part of this study. Table 3 - 1 shows the surface cooling system control parameters for all the underground waiting areas (stations).

Table 3 - 1: Mine surface cooling system control parameters

Control variable	Control parameter	Control action
Temperature <i>(Off-peak and standard hours).</i>	Not applicable.	Maintain existing system operation.
Temperature <i>(Peak hours: 18:00 – 20:00 – summer 17:00 – 19:00 - winter).</i>	Above 25.5 °C WB.	Start fridge plants and auxiliary equipment. If all the fridge plants are already in operation, keep them running.
	Below 25.5 °C WB.	Stop all the fridge plants, evaporator pumps, condenser pumps, BAC fans, and condenser fans.

Figure 3 - 4 illustrates the flow chart to be followed when implementing the load management strategy. The improved operating schedules are to be implemented during the evening peak when the underground station temperatures are below 25.5°C WB, as already explained. If the underground station temperatures are above 25.5°C WB during peak time, an additional fridge plant must be operation for about 15 minutes to meet the cooling demand.

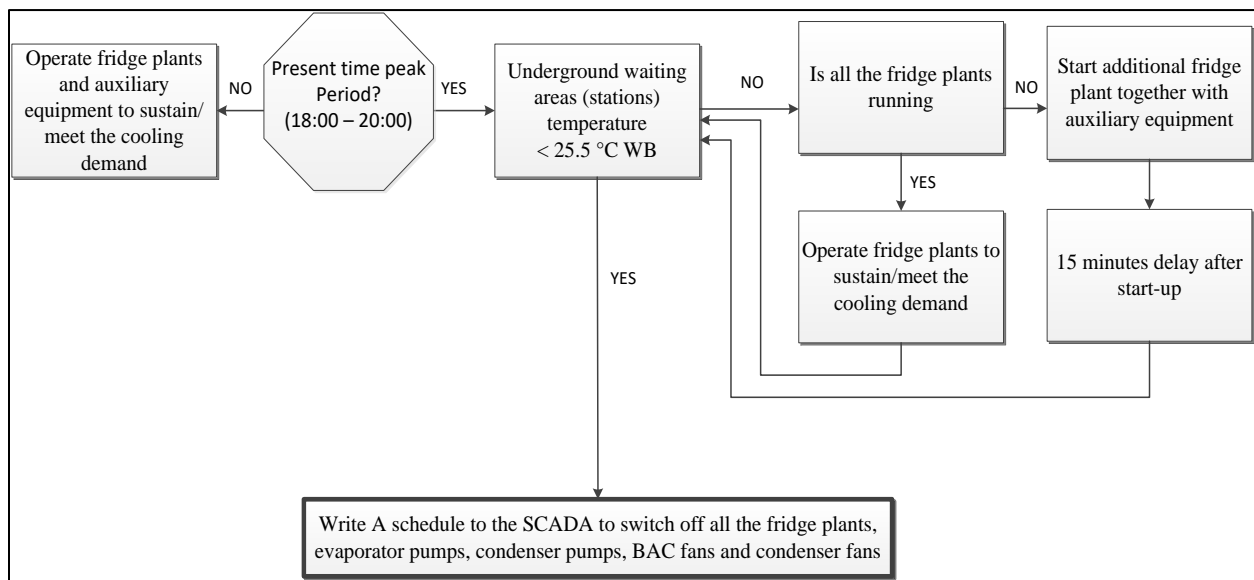

Figure 3 - 4: Load management strategy and control layout

The EnMS that specialises in cooling and ventilation is used to aid in achieving the objectives of this study. The EnMS uses the developed strategy to propose optimal running schedules for the surface cooling system equipment, to use less electricity during the expensive evening peak period. The switching off is done without affecting the underground environmental conditions and productivity. The proposed optimal running schedules will be executed by the control room operators on a day to day basis during the weekdays in the evening peak periods. The schedules will be implemented on the following sub-systems which form part of the surface cooling system:

- the BAC circuit,
- the evaporator circuit,
- the condenser circuit,
- the cooling tower and transfer circuit, and
- the fridge plants.

Figure 3 - 5 illustrates the functional specification of the EnMS control. The EnMS will monitor the measuring instruments, i.e., the temperature and RH sensors. The EnMS has the following functions and capabilities, but not limited to:

- The EnMS monitors, integrates, simulates, and optimises the control elements of the cooling system.
- EnMS can access the Supervisory Control and Data Acquisition (SCADA) of the mine via Open Platform Communications (OPC) to retrieve the cooling system auxiliary statuses, temperatures, pressures, flow rates, etc. Based on these and other inputs, the EnMS can be allowed to:
 - use OPC, connect to the SCADA through the relevant network,
 - monitor fridge plants statuses and their power consumption data,
 - monitor pumps statuses and their power consumption data,
 - propose the optimal running schedules for the surface cooling system and all its components to achieve optimum load reduction in peak hours.

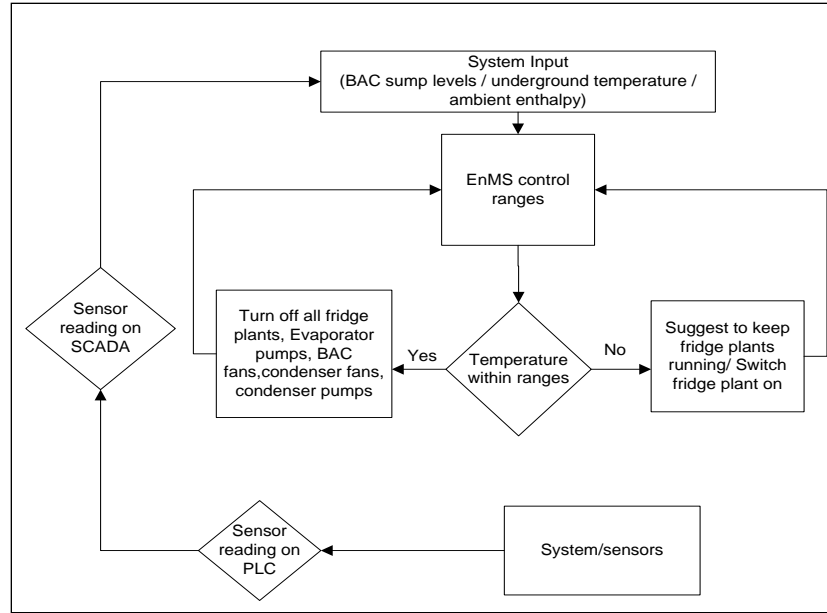

Figure 3 - 5: EnMS and PLC functional specification flow chart

3.3 Verification of the developed strategy

Two case studies were selected to verify the developed strategy. As previously mentioned the strategy is versatile and can be applied to closed and semi-closed loop systems. Mine A with a closed loop surface cooling system; is used as Case Study 1. Mine B with a semi-closed loop surface system, is used as in Case Study 2.

Mine A

Figure 3 - 6 shows the system layout of Mine A. There are four ammonia fridge plants in parallel which supply chilled water of 2.5°C to a two-stage BAC on surface at Mine A. The two-stage BAC and the four ammonia fridge plants are in a closed loop system configuration. The water temperature from the BAC sump back to the fridge plants is approximately 11°C.

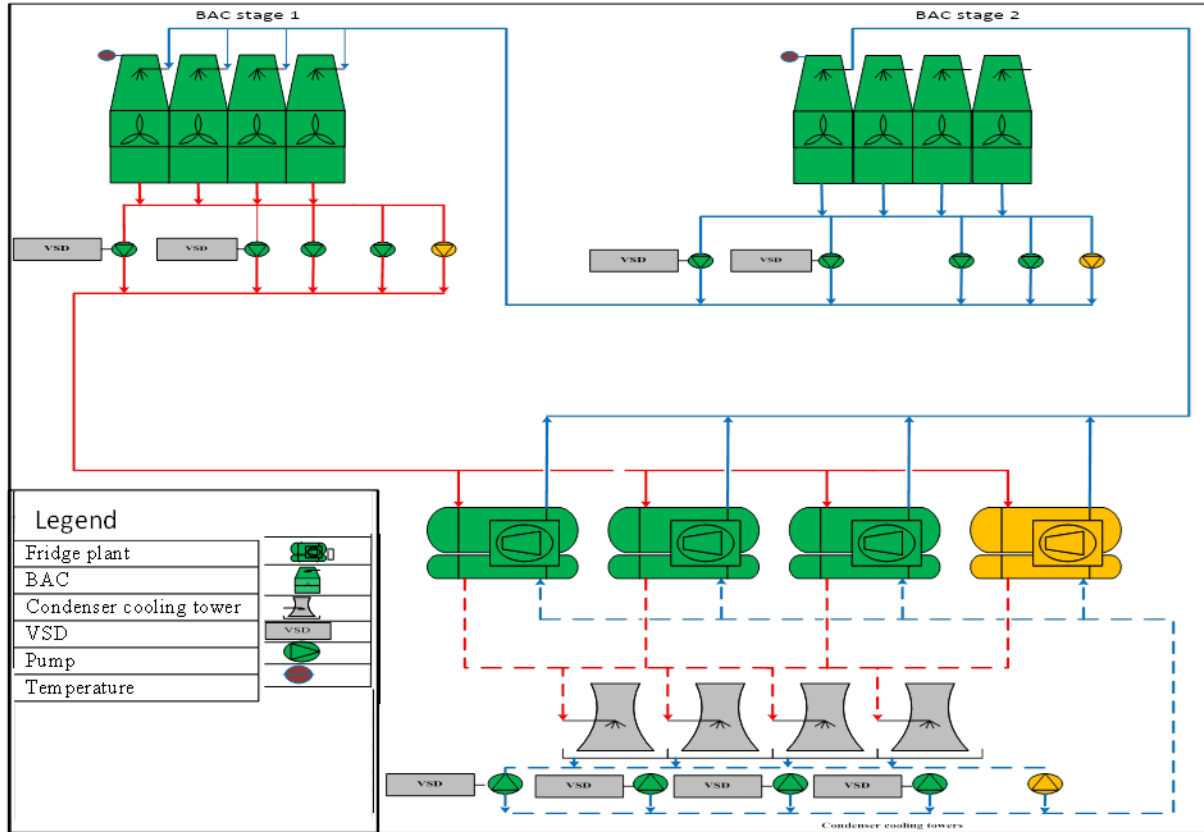

Figure 3 - 6: Mine A surface cooling system layout

The four ammonia fridge plants operate at a Coefficient of Performance (COP) of 5.5 and a nominal cooling capacity of 24 MW. The ambient air is cooled down to $\pm 7^{\circ}\text{C}$ WB by the two-stage BAC. This cooled down air is supplied at 728 kg/s down to the main shaft for underground cooling.

The surface fridge plants specifications are displayed in Table 3 - 2 below. The four ammonia fridge plants are Howden trademark with a screw compressor type. These fridge plants produce cold water at 2.5°C that is sent to the BACs.

Table 3 - 2: Mine A fridge plant specifications

Description	Unit
Number of fridge plants	4
Make	Howden

Compressor type	Screw
Refrigerant	ammonia
Voltage (V)	11000
COP	5.5
Evaporator outlet temperature (°C)	2.5
Condenser inlet temperature (°C)	22
Evaporator water flow (kg/s)	141
Condenser water flow (kg/s)	212
Evaporator pump motor rating (kW)	132
Number of evaporator pumps	5
Condenser pump motor rating (kW)	110
Number of condenser pumps	5

The surface condenser cooling tower specifications are displayed in Table 3 - 3. Mine A has an average of 18°C DB ambient temperature. The condenser cooling towers are used as the heat extraction for the system. They are used to cool off the circulating water from the condenser side of the fridge plants from approximately 31°C to about 23°C using the ambient air as a coolant.

Table 3 - 3: Mine A condenser cooling towers specifications

Description	Unit
Number of cooling towers	4
Water inlet temperature (°C)	31
Water outlet temperature (°C)	23
Water flow (kg/s)	210
Air inlet DB temperature (°C)	18

The surface BAC specifications are displayed in Table 3 - 4. The BACs receive the cold water from the fridge plants. The inlet water temperature is about 3°C, rather than the 2°C produced

from the fridge plants. This is because of the long distances of transportation which cause friction in the system. The friction causes the inlet temperature to increase a fraction.

Table 3 - 4: BAC specifications

Description	Unit
Number of BACs	1
Water inlet temperature (°C)	3
Water outlet temperature (°C)	11
Water flow (kg/s)	600
Airflow (kg/s)	728
Air inlet WB temperature (°C)	17
Air outlet WB temperature (°C)	7
Spray pump motor rating (kW)	75
Number of spray pumps	5

Literature shows that one of the common strategies to achieve energy efficiency is to install VSDs. There are VSDs installed at Mine A to achieve energy efficiency on the surface cooling system as part of this study DSM initiative. The following infrastructure is installed on the system:

- four VSDs on the evaporator pumps,
- four VSDs on the condenser pumps, and
- four electrical actuated control valves on the condenser lines.

Figure 3 - 7 shows the evaporator pumps of the surface cooling system at Mine A. these are the real evaporator pumps at Mine A used to circulate the water through the fridge plants to the BACs.



Figure 3 - 7: Evaporator pumps of Mine A surface cooling system⁶

The VSDs are set at a specific frequency which will deliver optimum cold water flow required to meet the cooling demand. The ramping up and down of the frequency throughout the day as ambient conditions change results in energy efficiency.

The main objective is to achieve load reduction during the critical Eskom expensive evening peak period (18:00 – 20:00 during summer and 17:00 – 19:00 in the winter season), as already mentioned. The comeback load can be shifted to the off-peak periods. Application of the developed load management strategy must not affect the mining working conditions. Both Mine A and Mine B are in accordance to Megaflex TOU Tariff structure. The cooling demand may vary depending on the following:

- the ambient temperature,
- the volume of cold water used on underground operations,
- the volume of cold water used for the BAC systems, and
- the operational time of the BAC fans during the day.

⁶Thabiso S. Moropa personal photo. Mine A evaporator pumps

Using data from the installed calibrated power meters, the power profiles can be compiled. The actual power profile before implementing the load management strategy is referred to as a baseline, which is used to determine the cost and energy savings. 24-hour baseline profiles need to be compiled using data of three or more months.

The power baseline profiles of Mine A are shown in Figure 3 - 8. This baseline includes the ammonia fridge plants, evaporator pumps, condenser pumps, BAC fans, and the condenser fans. Three months of data was used to compile this baseline. Clearly, there is no evening peak reduction on the surface cooling system. The baseline data used can be found in Appendix 2.

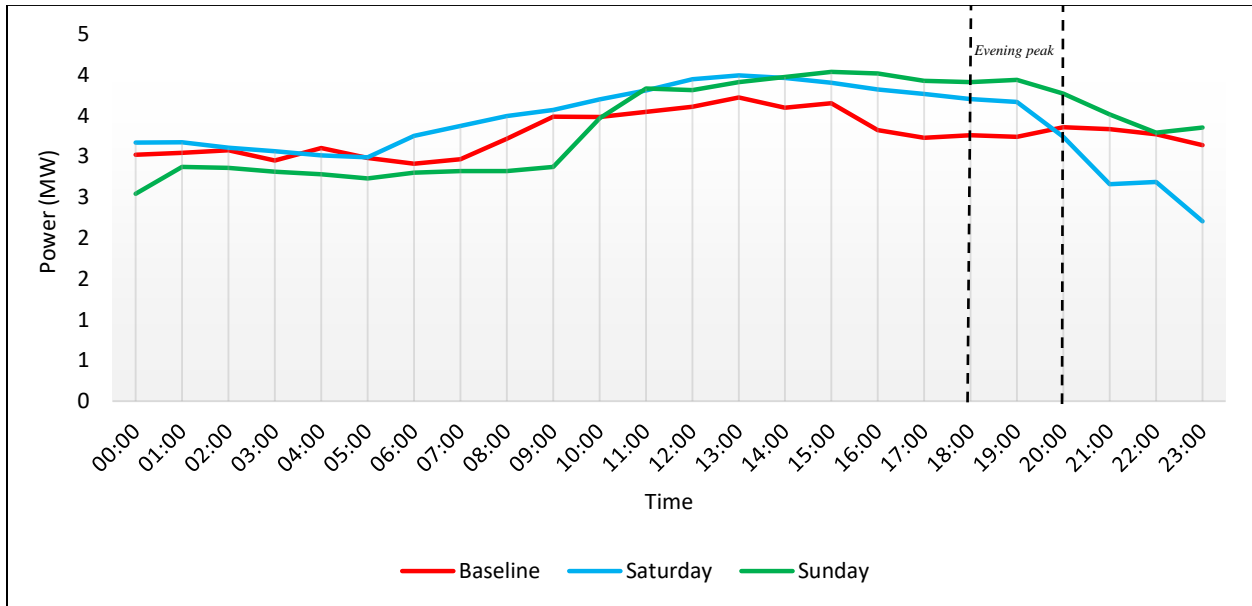

Figure 3 - 8: Mine A baseline profiles

Load reduction tests will be conducted to verify the strategy, as mentioned before. The purpose of the tests is to determine whether it is possible to switch off the surface cooling system equipment, i.e. fridge plants, evaporator pumps, condenser pumps, BAC fans and condenser fans during the weekdays’ evening peak periods. This should be done without adversely affecting the underground environmental conditions.

Temperature (DB) and RH sensors (Tiny Tags) were installed underground at Mine A. These sensors are standalone units capable of measuring DB temperature and RH, and storing the

logged data internally. The sensors were left underground for a week to monitor the temperature and RH under normal operations. Simultaneously, the power usage of the cooling systems (evaporator pumps, condenser pumps, fridge plant compressors, BAC fans, etc.) was also monitored and logged. These measurements were used to compile the baselines.

The portable sensors only measure DB temperature and RH. These sensors are effective between -25°C to 85°C DB and below 95% RH. The WB temperature is then calculated from the RH and DB temperature readings using Equation 6 that was derived by Roland Stull in 2011 [56].

$$T_{WB} = T_{DB} \operatorname{atan} \left[0.151977(RH\% + 8.313659)^{\frac{1}{2}} \right] + \operatorname{atan}(T_{DB} + RH\%) - \operatorname{atan}(RH\% - 1.676331) + 0.00391838(RH\%)^{\frac{3}{2}} \operatorname{atan}(0.023101RH\%) - 4.686035 \quad \text{Equation 6}$$

Where:

T_{WB} : WB temperature,

T_{DB} : DB temperature, and

RH : relative humidity.

A week later on a no working weekend, all the fridge plants, the evaporator pumps, the condenser pumps and the condenser fans were switched off during the evening peak period. After the load reduction test was conducted, the logged data was analysed. The load reduction test results were compared to the baseline.

The focus of the analysis was on the two evening peak hours, to see the effect of switching off the surface cooling system equipment on the temperatures of different mining conditions. The sensors were installed at Mine A on three main shaft levels, i.e. 95 level, 100 level and 110 level. These measurement points are illustrated in Figure 3 - 9.

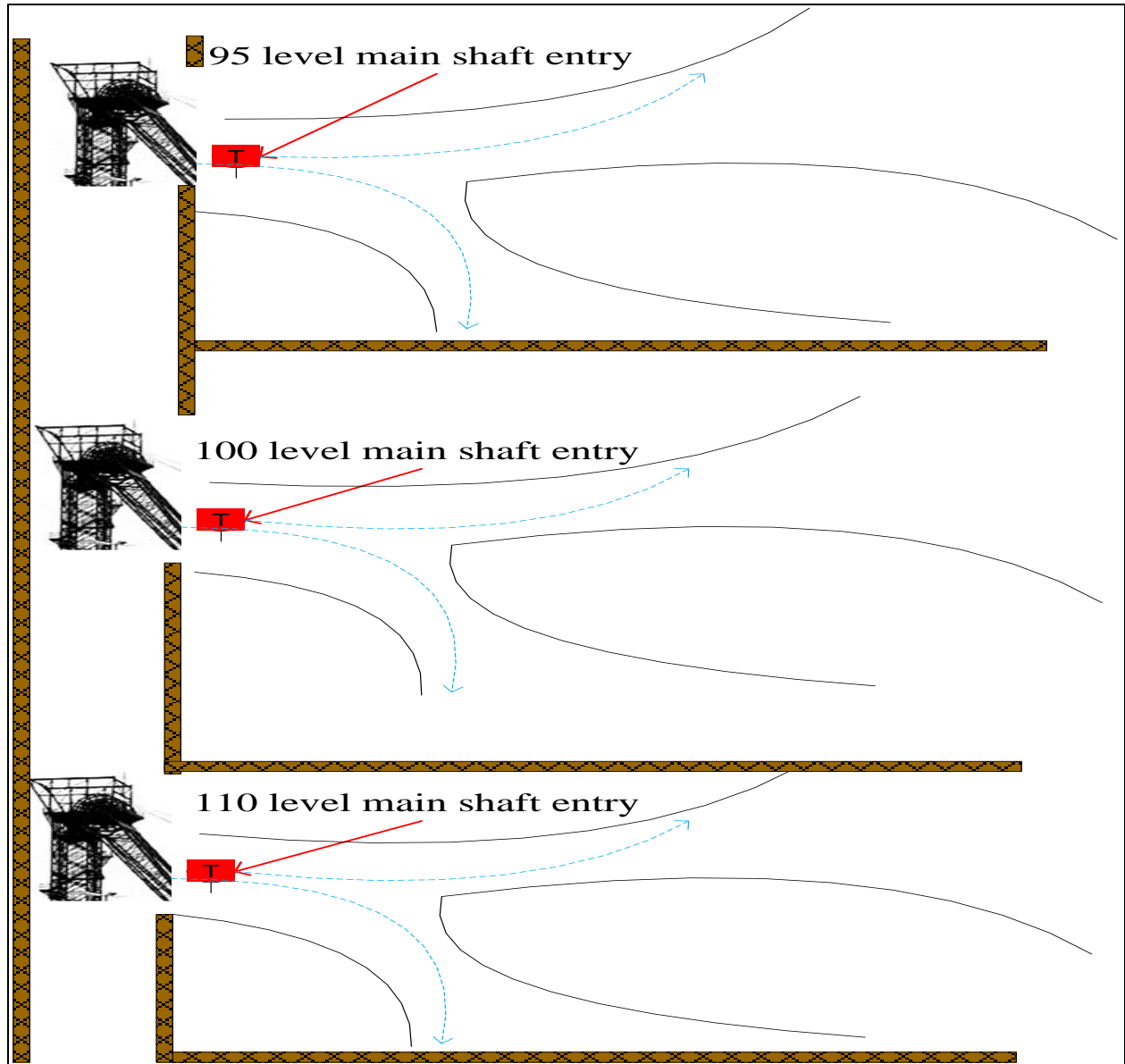

Figure 3 - 9: Mine A underground measuring points

Figure 3 - 10 shows the ambient WB temperature profiles. The ambient WB temperature is on the y-axis and time on the x-axis of the figure. From the figure, it can be seen that the two profiles, i.e. the baseline and the test period have a linear relationship. However, the load reduction test period was warmer when compared to that of the baseline. The ambient WB temperature data was retrieved from the mine’s SCADA, which is logged by a weather station on the surface.

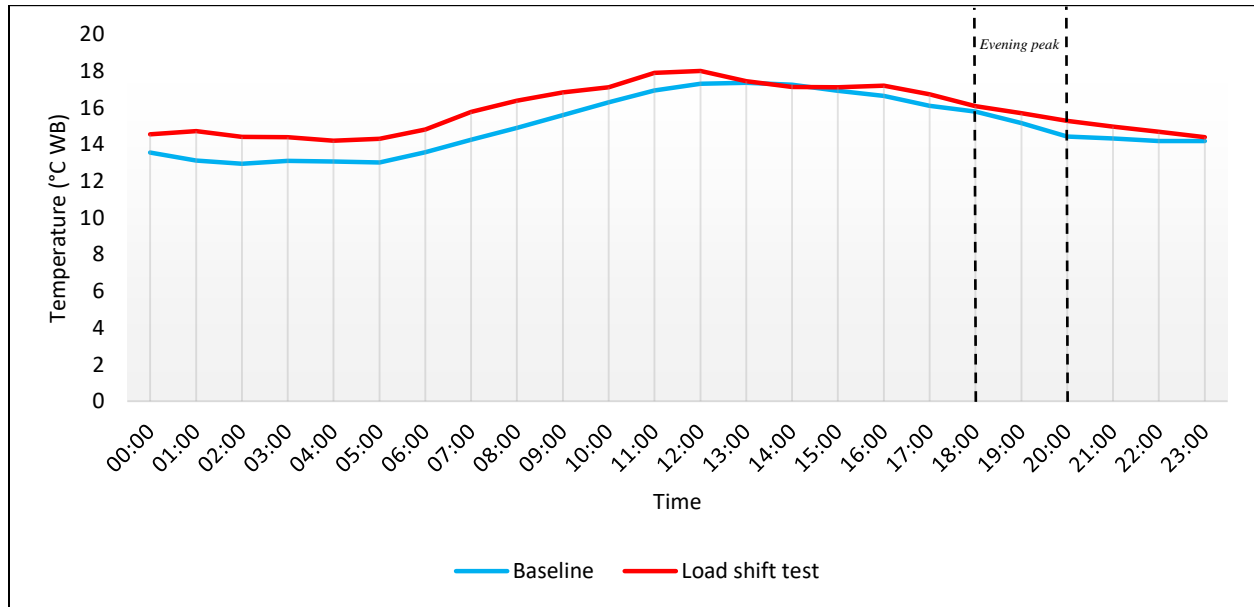

Figure 3 - 10: Ambient WB temperatures at Mine A

The difference in ambient temperature between the baseline and test period in the evening peak period is below 1.0°C WB. Table 3 - 5 shows the ambient WB temperature summary of the two periods.

Table 3 - 5: Ambient temperature summary for Mine A

	Baseline (°C WB)	Load reduction test (°C WB)	Absolute difference (°C WB)
Minimum	12.9	14.2	1.3
Average	15.0	15.8	0.8
Maximum	17.4	18.0	0.6
Average (18:00 – 20:00)	15.5	15.9	0.4

The underground WB temperatures for both periods showed the same trend throughout the day, except during the evening peak period. The 95 level main shaft WB temperature increased steadily by an average of 0.7°C WB over the two-hour period. Figure 3 - 11 shows the WB temperature profiles of 95 level. It can be seen that the temperature immediately decreases after 20:00 when the surface cooling system is operated again to meet the cooling demand. It took

approximately four hours to normalise the underground temperatures at this level. However, the temperatures did not exceed the maximum limit of 25.5°C WB.

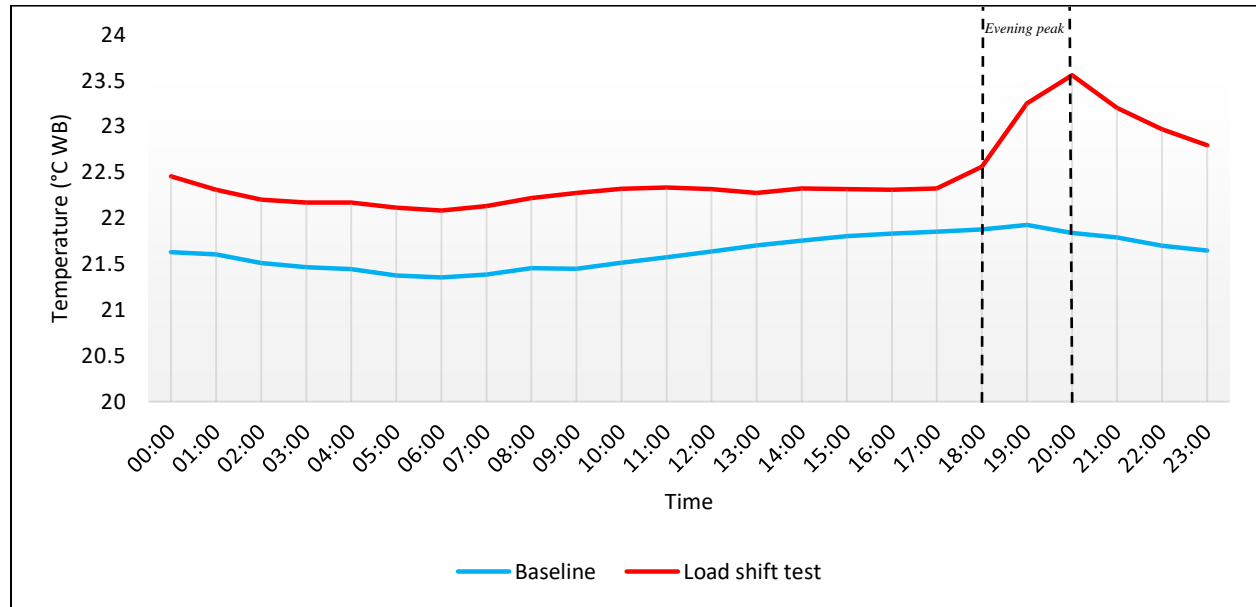

Figure 3 - 11: Mine A 95 level main shaft – air WB outlet temperature

Table 3 - 6 shows that there is an average difference of 1.0°C WB between the baseline and the load reduction test period during the evening peak on this level. An average of 21.9°C WB occurred during the evening peak period.

Table 3 - 6: Temperature summary of 95 level main shaft for Mine A

	Baseline (°C WB)	Load reduction test (°C WB)	Absolute difference (°C WB)
Minimum	21.4	22.1	0.7
Average	21.6	22.5	0.9
Maximum	21.9	23.6	1.7
Average (18:00 – 20:00)	21.9	22.9	1.0

100 level results reflect the same trend as of 95 level. On this level, the temperature increased by an average of 0.9°C WB over the two-hour peak period. The temperature profiles for 100 level are shown in Figure 3 - 12. The air WB temperature is on the y-axis and time on the x-axis. It

also took approximately four hours to normalise the underground temperatures at this level. However, the temperatures did not exceed the maximum limit.

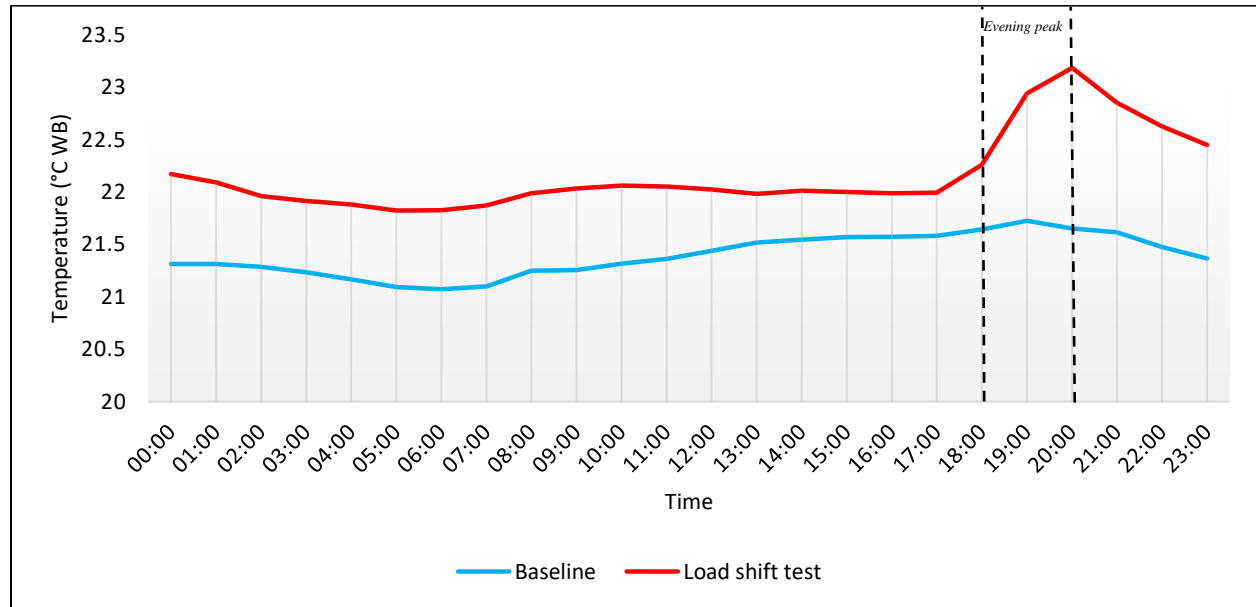

Figure 3 - 12: Mine A 100 level main shaft – air WB outlet temperature

Table 3 - 7 shows the WB temperature summary of 100 level before and after the load reduction test. There was an average of 21.7°C WB temperature during the evening peak period, with a difference of 0.9°C WB between the baseline and the load reduction period.

Table 3 - 7: Temperature summary of 100 level main shaft for Mine A

	Baseline (°C WB)	Load reduction test (°C WB)	Absolute difference (°C WB)
Minimum	21.1	21.8	0.7
Average	21.4	22.2	0.8
Maximum	21.7	23.2	1.5
Average (18:00 – 20:00)	21.7	22.6	0.9

The temperature increased by 0.5°C WB with an average difference between the baseline and the test period of 0.9°C WB on the 110 level. Figure 3 - 13 shows the temperature trends of 110 level. It also took approximately four hours to normalise the underground temperatures at this level. And again, the temperature did not surpass the maximum limit.

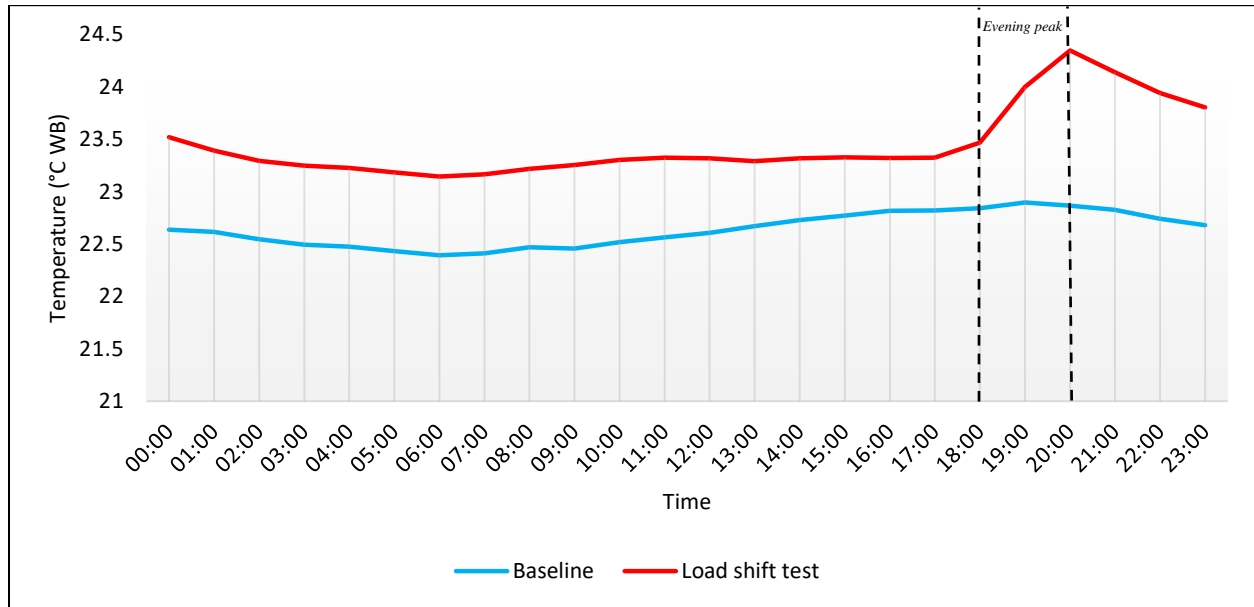

Figure 3 - 13: Mine A 110 level main shaft – air WB outlet temperature

Table 3 - 8 shows the WB temperature summary of 110 level. There was an average of 22.9°C WB temperature during the evening peak period, with a difference of 0.9°C WB between the baseline and the load reduction period. All the temperature readings did not exceed the maximum set limit of 25.5°C WB.

Table 3 - 8: Temperature summary of 110 level main shaft for Mine A

	Baseline (°C WB)	Load reduction test (°C WB)	Absolute difference (°C WB)
Minimum	22.4	23.1	0.7
Average	22.6	23.5	0.9
Maximum	22.9	24.4	1.5
Average (18:00 – 20:00)	22.9	23.7	0.8

Taking into consideration the installed capacities of the fridge plants, the evaporator pumps, the condenser pumps and the BAC fans, the expected possible load to be shifted can be calculated. In this case study, 3.0 MW is a possible load that can be shifted. Shifting 3.0 MW out of the evening peak period can result in annual electricity cost savings of R1.6 million, using

2016/2017 Eskom Megaflex Tariff structure. The proposed power profile is illustrated in Figure 3 - 14.

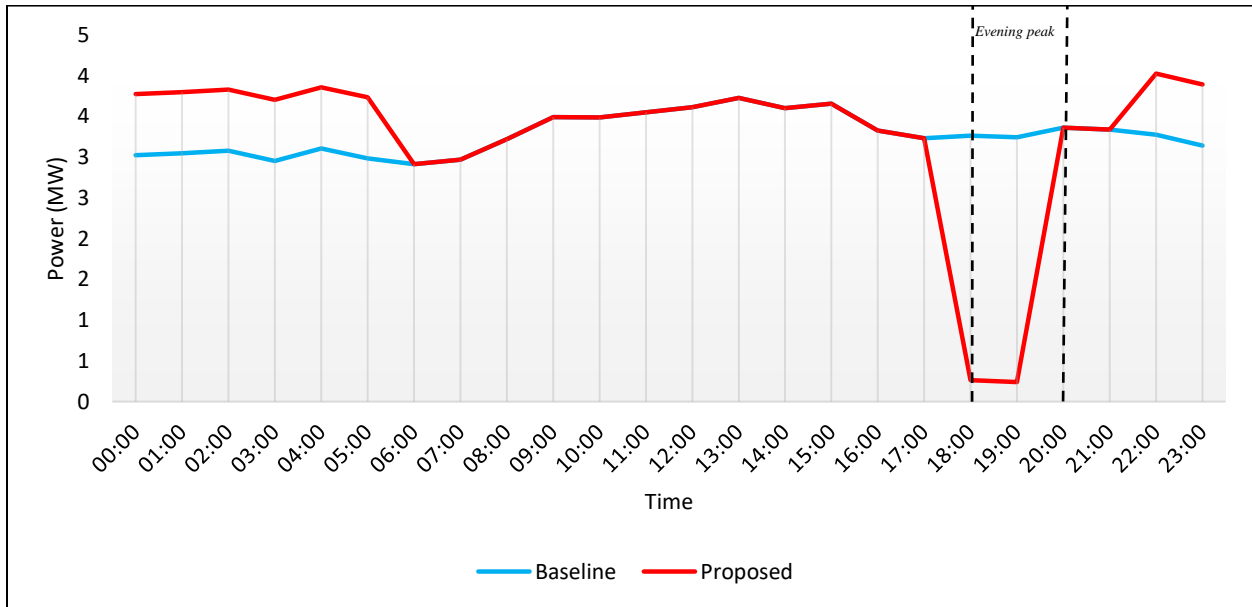

Figure 3 - 14: Mine A surface cooling system proposed power profiles of the simulation

Figure 3 - 15 and Figure 3 - 16 illustrate the electricity cost of the baseline and the proposed power profiles respectively. It can clearly be seen that the peak periods have higher electricity costs. This is because Megaflex Tariffs structure bills more during the peak periods.

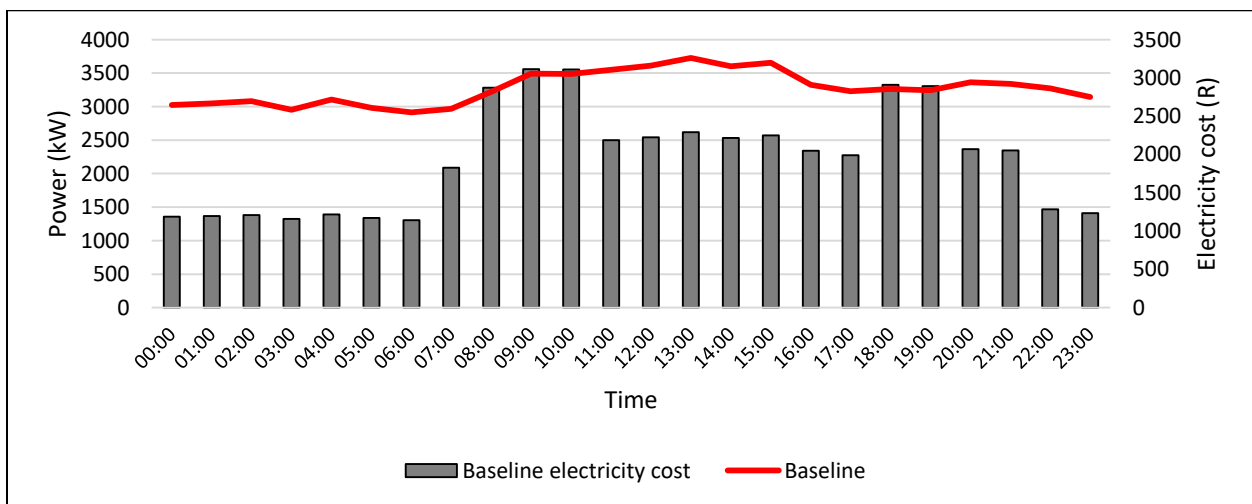

Figure 3 - 15: Mine A weekday average electricity cost calculated from weekday baseline average power consumption

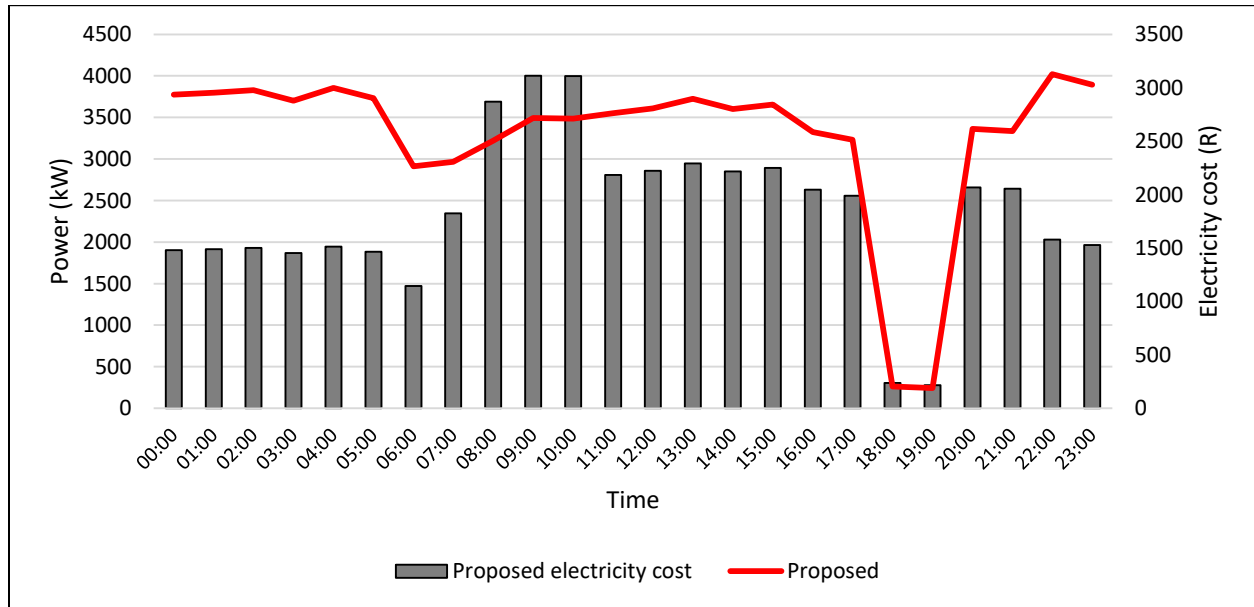

Figure 3 - 16: Mine A weekday average electricity cost calculated from weekday proposed average power consumption

The power profiles of the baseline and the load reduction test period can be seen in Figure 3 - 17. These profiles illustrate that the load reduction during the evening peak period had taken place. This load reduction test resulted in 2.8 MW load being shifted out of the expensive evening peak period.

The 2.8 MW load reduction has an estimated annual cost savings of R1.5 million, using 2016/2017 Eskom Megaflex Tariffs, during a summer season. The electricity cost of the load reduction is illustrated on Figure 3 - 18. Figure 3 - 18 has two y-axis, left y-axis represents the average power consumptions and the right y-axis is the electricity cost based on the consumed time is on the x-axis.

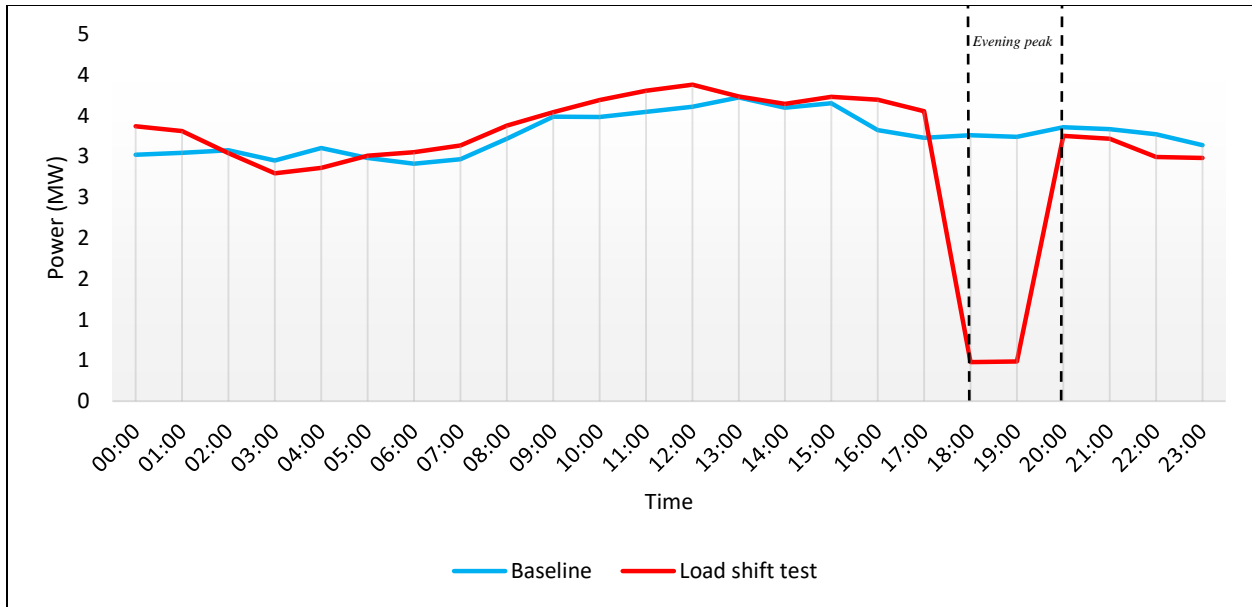

Figure 3 - 17: Mine A surface cooling system power profiles of load reduction test

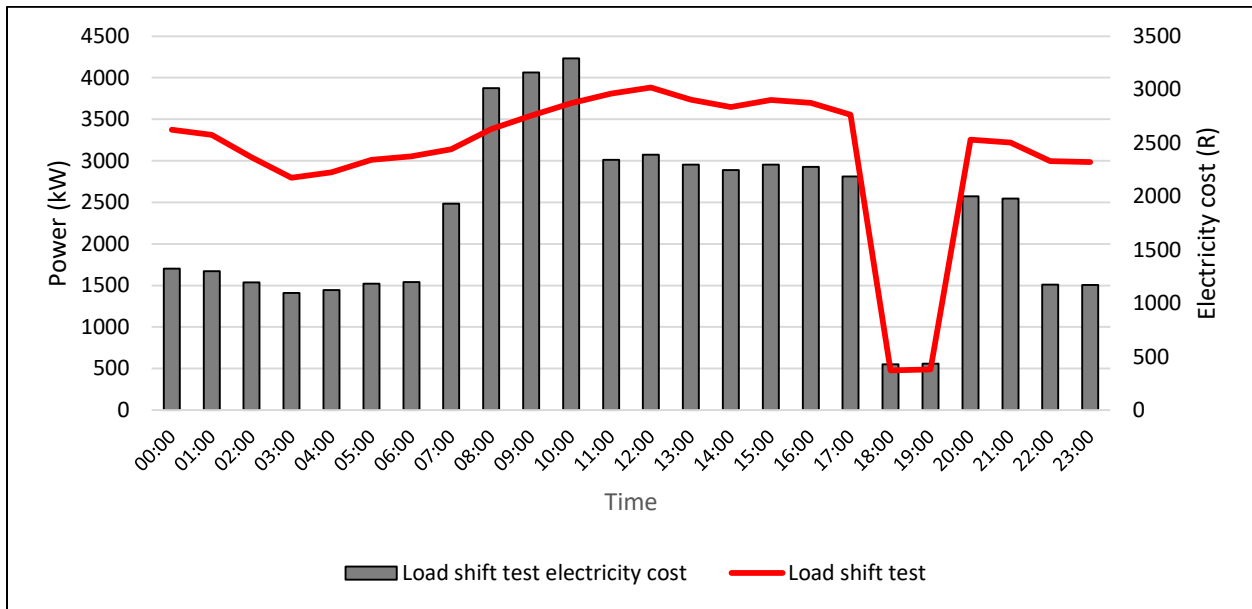

Figure 3 - 18: Mine A weekday average electricity cost calculated from load reduction average power consumption

Comparing the estimated load reduction and the load reduction test results, there is a difference of 0.2 MW. This can be because of the difference in running hours (cooling demand) of the equipment during the baseline period and the load reduction test period. As it was illustrated in Figure 3 - 10, the load reduction test period was warmer; this resulted in an increase in the

cooling demand. Also, Mine A personnel requested to keep the BAC fans running during the evening peak periods.

Mine B

Mine B has two sets of fridge plants, Top fridge plants and Pamodzi fridge plants. The Pamodzi fridge plants form part of the surface cooling system. The surface cooling system consists of five R34a fridge plants which supply chilled water at 3.0°C to the surface BACs. The surface BACs and the five fridge plants are in a semi-closed loop system configuration. The chilled water from the fridge plants passes through a valve which allows approximately 31.0 litres per second to the soft ice plants condenser cooling towers to prevent surging of the ice plants; and the remaining volume of cold water (± 447.0 l/s) goes to the surface BACs. The water temperature from the BAC sumps back to the fridge plants is approximately 10.0°C.

Pamodzi fridge plants operate at the COP of 5.7 and a nominal cooling capacity of 24 MW. Mine B has two BACs on the surface: main shaft BAC with four fans and a services shaft BAC with one fan. The main shaft BAC cools down the ambient air to approximately 7.0°C WB, and the services shaft cools down the ambient air to approximately 7.5°C WB. This cool air is supplied at 570 kg/s down to the main shaft for underground cooling. VSDs are installed on the five evaporator pumps of the Top fridge plants to control the water flow rate. There are also two VSDs installed on the Pamodzi fridge plants. These VSDs induce energy efficiency on the system. These installed VSDs form part of the DSM initiative that was previously implemented on this system.

Mine B has soft and hard ice plants integrated with the surface cooling system. The surface cooling system supplies the soft ice plants' condenser cooling towers with cold water to prevent surging of the ice plants. The soft ice plants are supplied by the Top fridge plants, from the storage capacity (8 Ml dam) another source of cold water. The hard ice plants are also supplied with cold water by the surface cooling system (Pamodzi fridge plants). Figure 3 - 19 shows a schematic layout of Mine B surface cooling system.

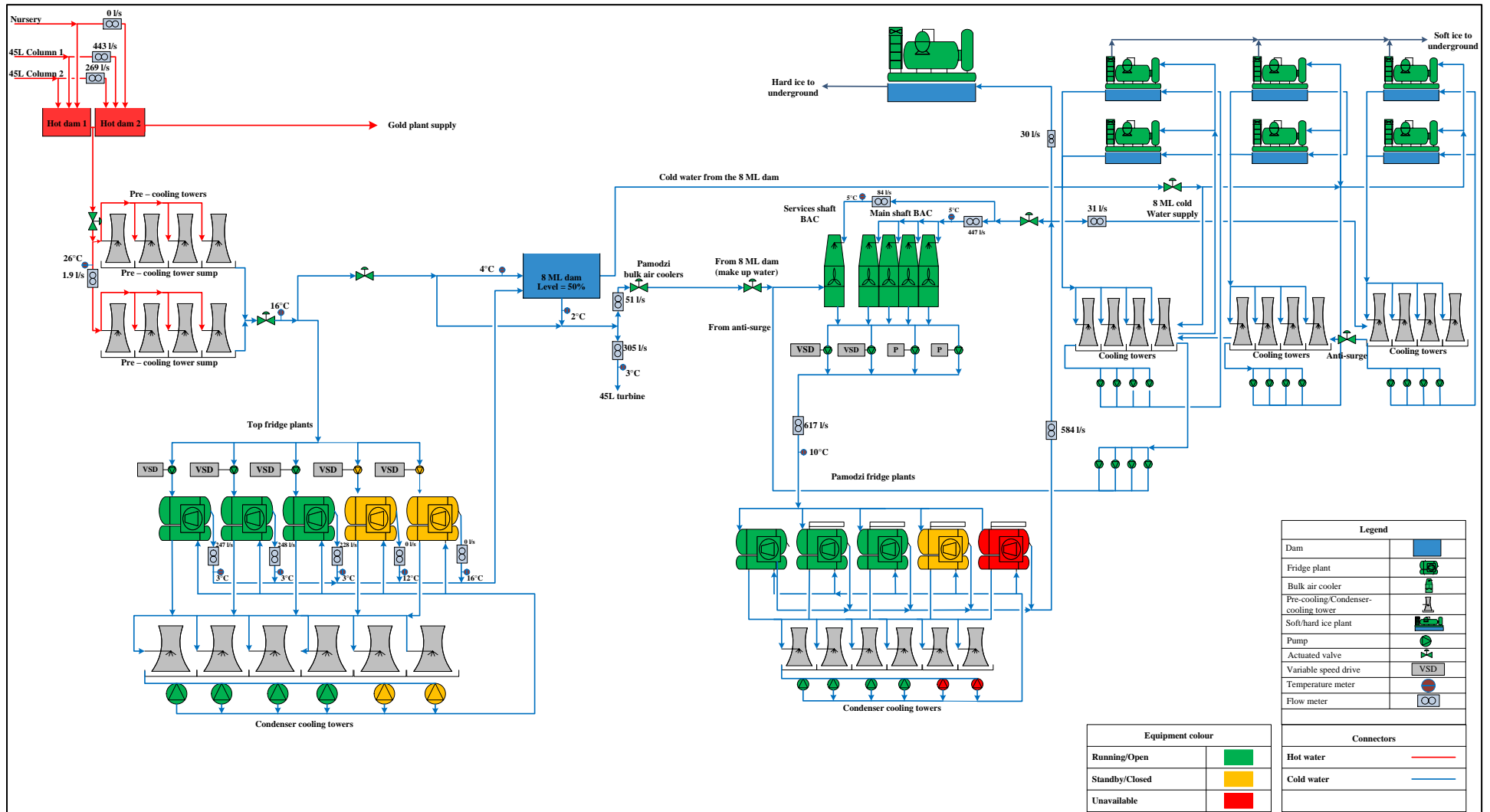

Figure 3 - 19: Mine B surface cooling system layout

The portable sensors (also used at Mine A) were used to measure the DB temperature and RH of the surface BACs outlet and underground BACs inlet air on 84 level. Additional temperature and RH measurements were taken on 120 level (underground BACs outlet) and the East-West (stopes entrance) split point of 120 level. A total of 4 were installed, the measurement points can be seen in Figure 3 - 20.

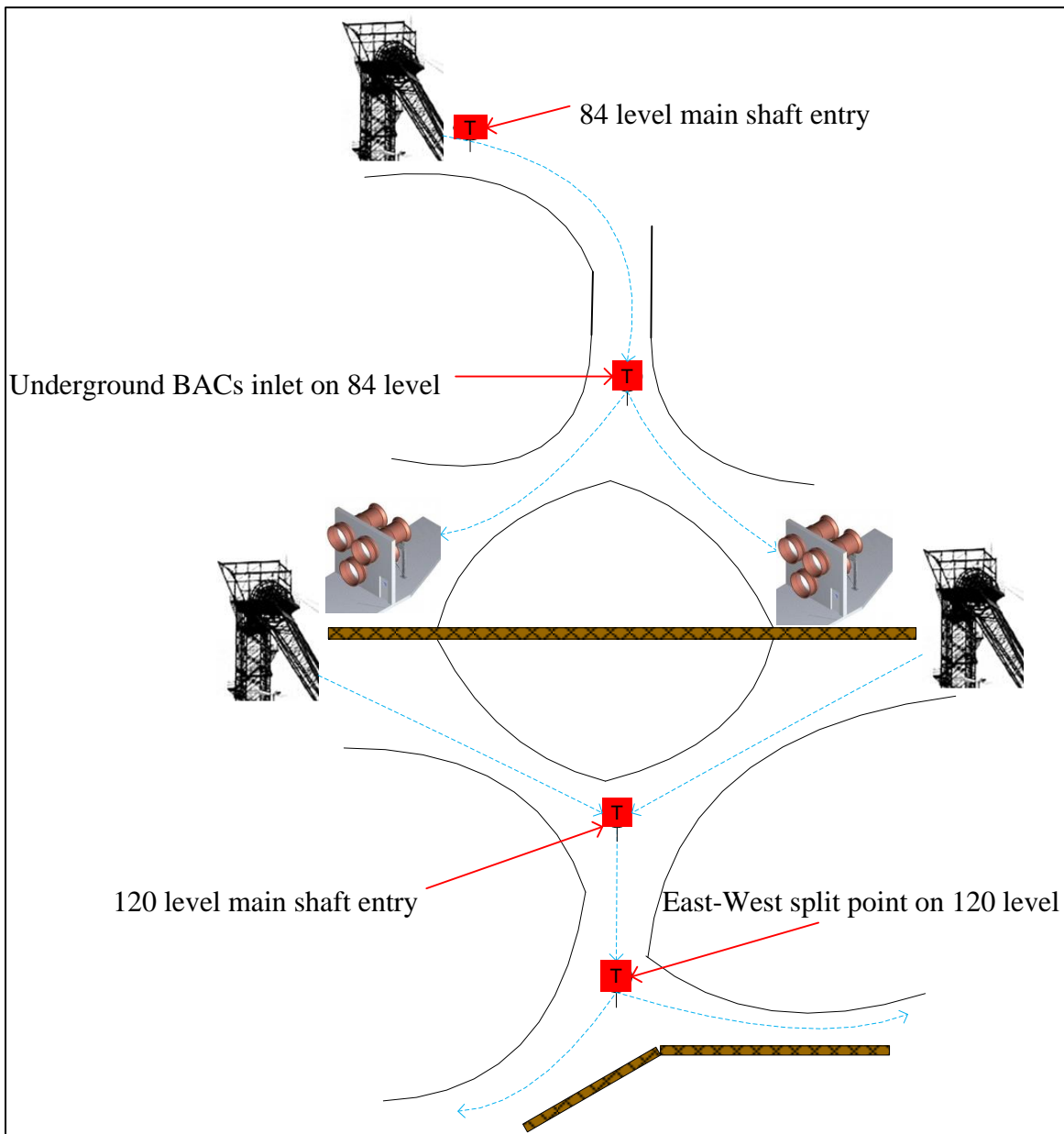

Figure 3 - 20: Mine B underground measuring points

The test period was warmer compared to the baseline period. This can be seen from the ambient WB temperature results shown in Figure 3 - 21. The ambient WB temperature data was retrieved from the weather station that is connected to the mine SCADA. During the load reduction test week, the region at which Mine B is situated experienced a heat wave. This resulted in higher temperatures, hence the huge difference in the ambient temperature profiles illustrated in Figure 3 - 21 below.

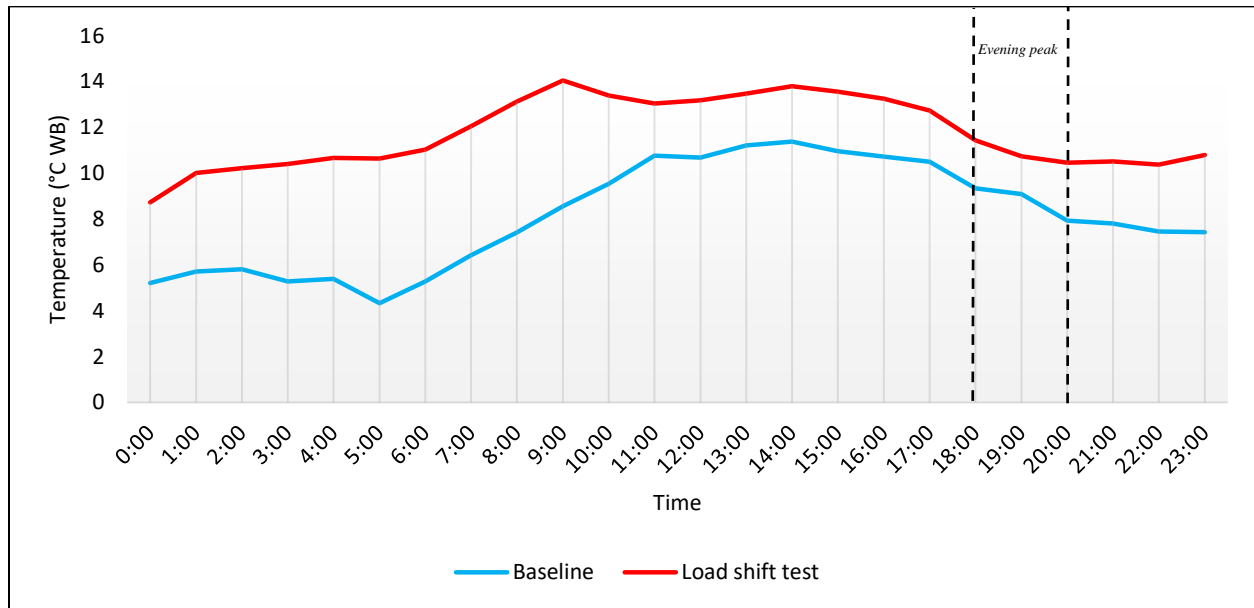

Figure 3 - 21: Ambient WB temperature at Mine B

Table 3 - 9 shows the ambient WB temperature summary of the two periods, baseline and the load reduction test period. It can clearly be seen that the load reduction period was warmer with an average of 11.1°C WB while there was an average of 9.2°C WB during the baseline period during the evening peak period.

Table 3 - 9: Ambient temperature summary for Mine B

	Baseline (°C WB)	Load reduction test (°C WB)	Absolute difference (°C WB)
Minimum	4.3	8.7	4.4
Average	8.1	11.7	3.6
Maximum	11.4	14.0	2.6
Average (18:00 – 20:00)	9.2	11.1	1.9

The surface cooling system supply cold air to underground mining levels down to 84 level. Figure 3 - 22 illustrates the temperature profiles of the baseline and the load reduction test periods. The two profiles have comparative trends throughout the day. During the evening peak period, there was an average difference of approximately 1.3°C WB between the normal operation and the load reduction period in the evening peak period.

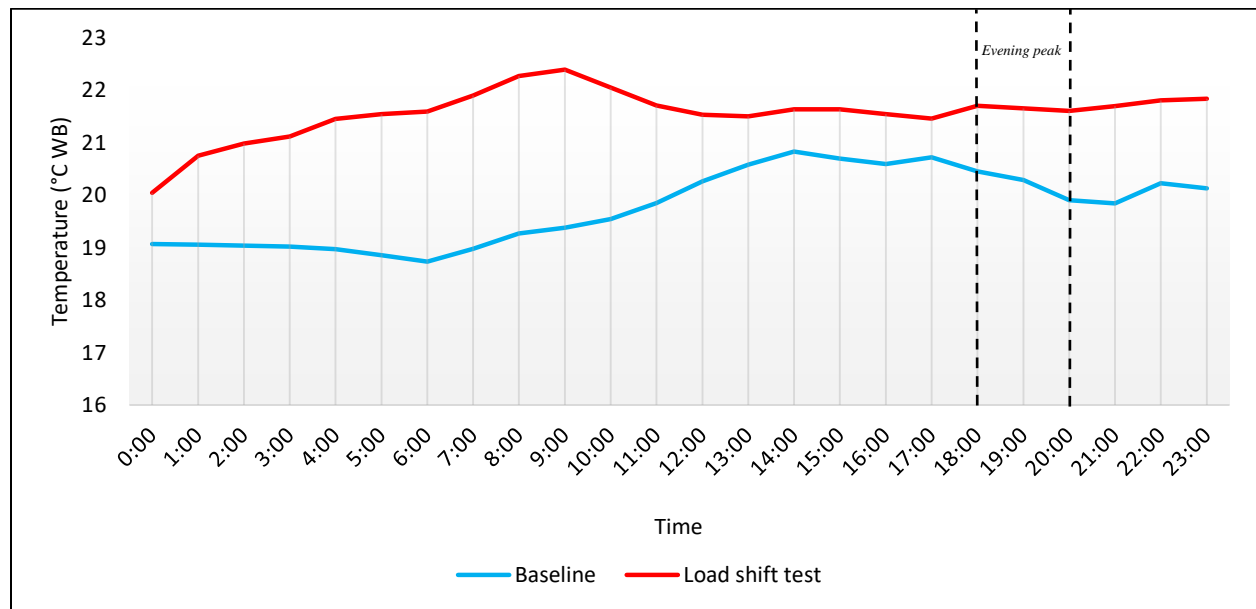

Figure 3 - 22: 84 level main shaft – air WB outlet temperature

Table 3 - 10 shows the WB temperature summary of 84 level main shaft. There was an average of 20.4°C WB temperature during the load reduction test, with a difference of approximately 1.3°C WB between the baseline and the load reduction period in the evening peak period. All the temperature readings did not exceed the maximum set limit of 25.5°C WB.

Table 3 - 10: Temperature summary of 84 level main shaft for Mine B

	Baseline (°C WB)	Load reduction test (°C WB)	Absolute difference (°C WB)
Minimum	18.7	20.1	1.4
Average	19.8	21.6	1.8
Maximum	20.8	22.4	1.6
Average (18:00 – 20:00)	20.4	21.7	1.3

Figure 3 - 23 shows the results of the underground BACs inlet air WB temperature. These underground BACs supply cooled air to lower mining levels, including 120 level. The inlet air to the underground BACs is from the 84 level main shaft outlets. There was a difference of approximately 1.0°C WB between the two periods, i.e. normal operation and load reduction period in the evening peak period. It is evident that the ambient conditions have a significant effect on the surface cooling system output.

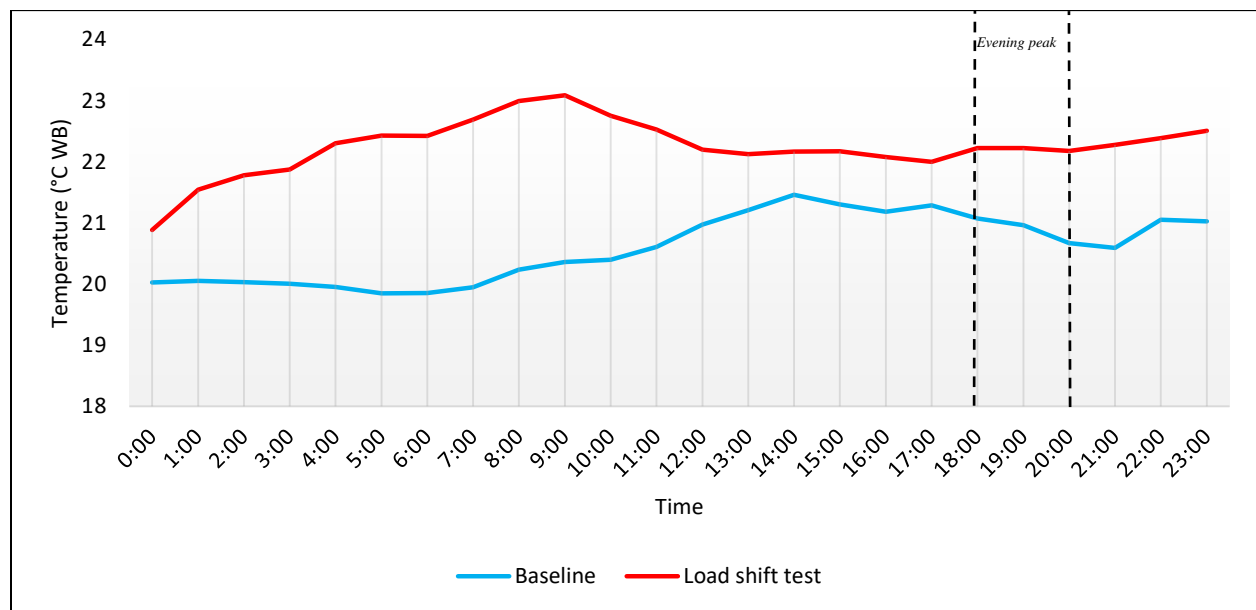

Figure 3 - 23: Underground BACs on 84 level – air WB inlet temperature

Table 3 - 11 shows the air WB temperature summary of 84 level underground BACs. There was an average of 21.0°C WB temperature in the evening during the load reduction. There was a

difference of approximately 1.31°C WB between the baseline and the load reduction period. All the temperature readings did not exceed the maximum set limit of 25.5°C WB.

Table 3 - 11: Temperature summary of 84 level underground BACs for Mine B

	Baseline (°C WB)	Load reduction test (°C WB)	Absolute difference (°C WB)
Minimum	19.9	20.9	1.0
Average	20.6	22.2	1.6
Maximum	21.5	23.1	1.6
Average (18:00 – 20:00)	21.0	22.2	1.2

The underground BACs on 84 level supply cooled air to the lower levels. Although the surface cooling system does not supply the cold air to the levels below 84 level, however, the inlet air temperature of the underground BACs on 84 level temperatures is affected by the surface cooling system. Therefore, it is important to monitor the conditions of the levels below 84 level.

The underground BACs outlet air WB temperature results can be seen in Figure 3 - 24 below. Comparing the two air WB temperatures, there was an average difference of approximately 0.7°C WB on this measuring point.



Figure 3 - 24: Underground BACs on 120 level – WB outlet temperature

Table 3 - 12 shows the air WB temperature summary of 120 level underground BACs. There was an average of 22.1°C WB temperature during the evening during the load reduction. There was a difference of approximately 0.7°C WB between the baseline and the load reduction period. All the temperature readings did not exceed the maximum set limit of 25.5°C WB.

Table 3 - 12: Temperature summary of 120 level underground BACs for Mine B

	Baseline (°C WB)	Load reduction test (°C WB)	Absolute difference (°C WB)
Minimum	21.8	22.2	0.4
Average	22.2	22.9	0.7
Maximum	22.7	23.5	0.8
Average (18:00 – 20:00)	22.1	22.8	0.7

Another temperature and RH sensor was placed at 120 level East-West split, i.e., entry to the working places (stopes). This is a critical point of measurement as the air temperature and RH here have a direct impact on the working areas. Figure 3 - 25 shows the WB temperature comparison of the baseline and the load reduction test period in the evening peak period. There was approximately 0.6°C WB difference between these two periods.

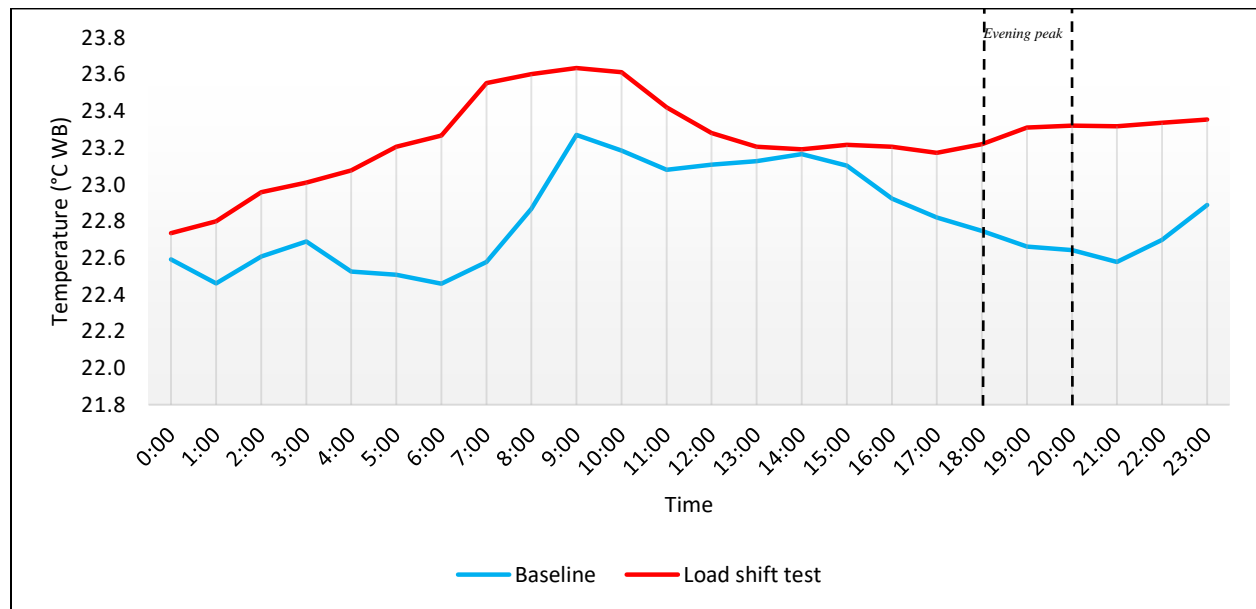

Figure 3 - 25: 120 level East-West split – WB inlet temperature

Table 3 - 13 shows the air WB temperature summary of 120 level, the East-West split point. There was an average of 23.3°C WB temperature in the evening during the load reduction. There was a difference of approximately 0.4°C WB between the baseline and the load reduction period. The temperatures at this level are higher. All the temperature readings did not exceed the maximum set limit of 25.5°C WB.

Table 3 - 13: Temperature summary of 120 level, the East-West split point for Mine B

	Baseline (°C WB)	Load reduction test (°C WB)	Absolute difference (°C WB)
Minimum	22.5	22.7	0.2
Average	22.8	23.3	0.5
Maximum	23.3	23.6	0.3
Average (18:00 – 20:00)	22.7	23.3	0.6

The expected load reduction can be calculated by taking into consideration the installed capacities, as it was estimated in Mine A. 3.2 MW is the possible load that can be reduced during the evening peak period at Mine B with annual electricity cost savings of R1.7 million, using 2016/2017 Eskom Megaflex Tariff structure. The proposed power profile for Mine B is illustrated in Figure 3 - 26. The baseline data used can be found in Appendix 2.

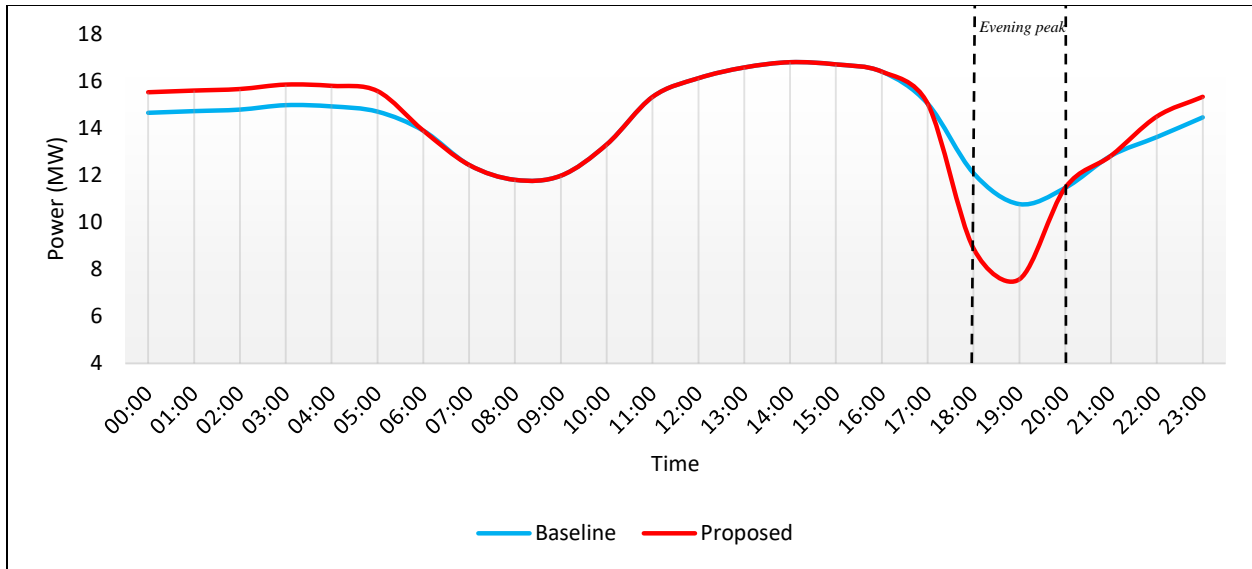

Figure 3 - 26: Mine B surface and underground cooling system proposed power profiles

Figure 3 - 27 and Figure 3 - 28 illustrates the electricity cost of the baseline and the proposed power profiles respectively. It can clearly be seen that the peak periods have higher electricity costs. This is because Eskom Megaflex Tariffs structure costs more in the peak periods.

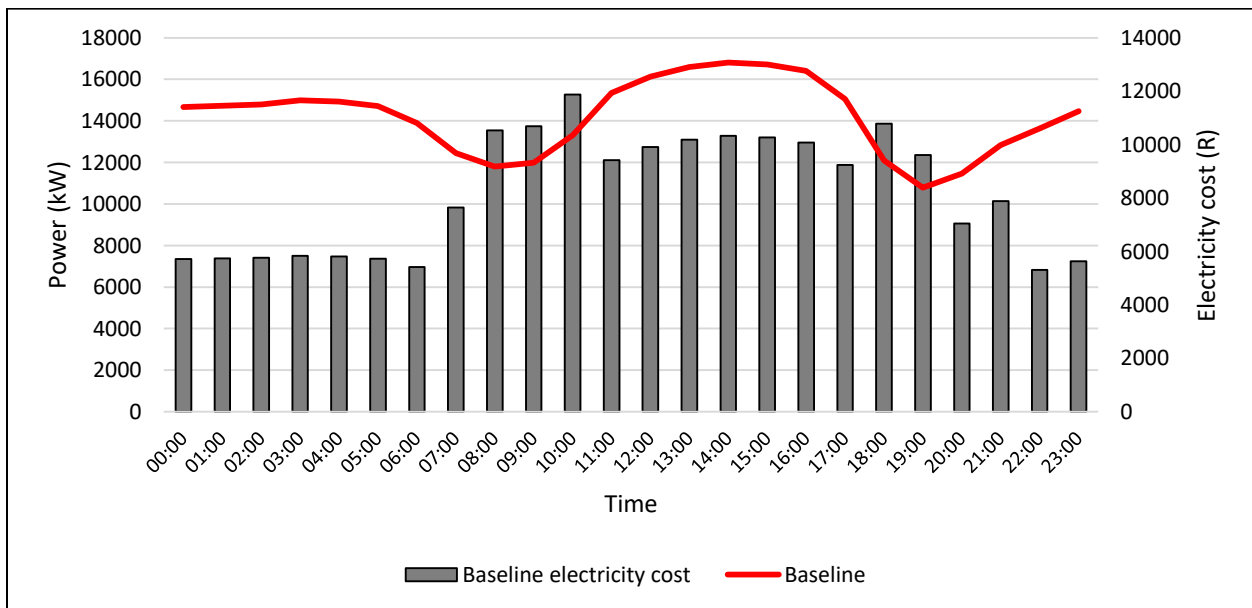

Figure 3 - 27: Mine B weekday average electricity cost calculated from weekday baseline average power consumption

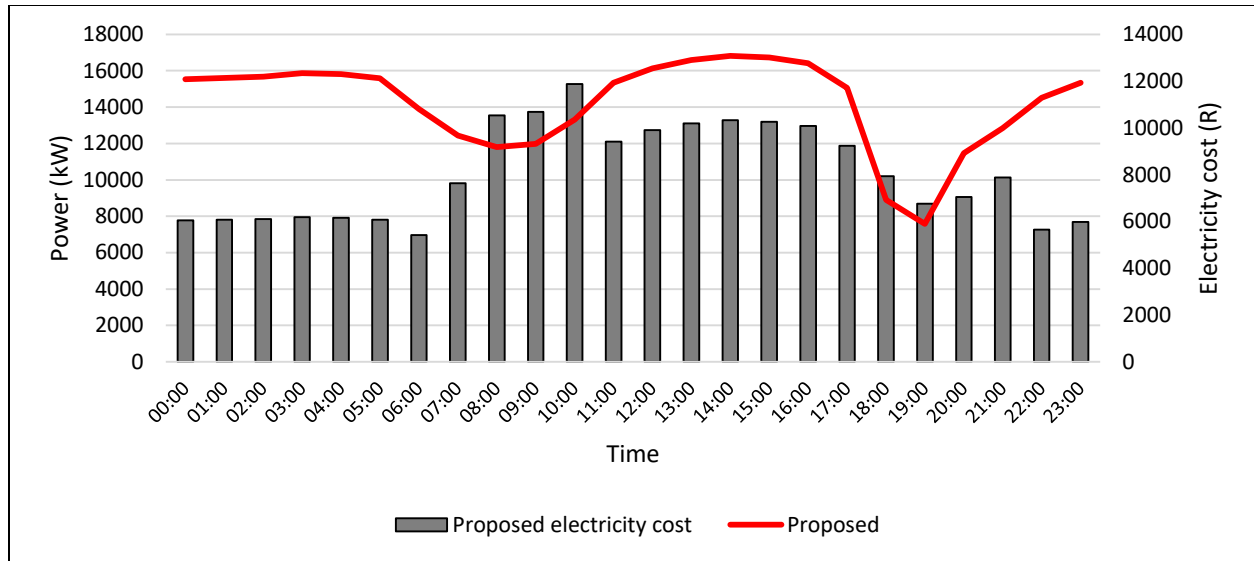

Figure 3 - 28: Mine B weekday average electricity cost calculated from weekday proposed average power consumption

The power profiles of the baseline and the load reduction test period can be seen in Figure 3 - 29. These profiles illustrate that the load reduction during the evening peak period had taken place. 1.8 MW load was shifted from the evening peak period. The 1.8 MW load reduction has an estimated annual cost savings of R900 000, using 2016/2017 Eskom Tariffs structure. The electricity cost of the load reduction is illustrated on Figure 3 - 18. Figure 3 - 18 has two y-axis, the left y-axis represents the average power consumptions and the right y-axis is the electricity cost based on what was consumed; time is on the x-axis.

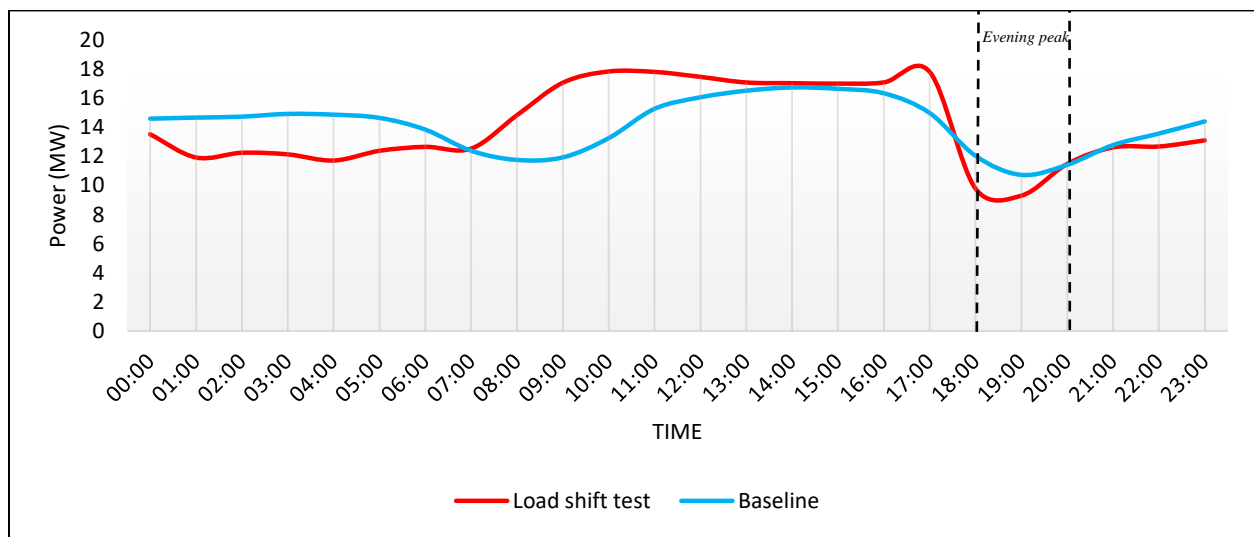

Figure 3 - 29: Mine B surface and underground cooling system power profiles

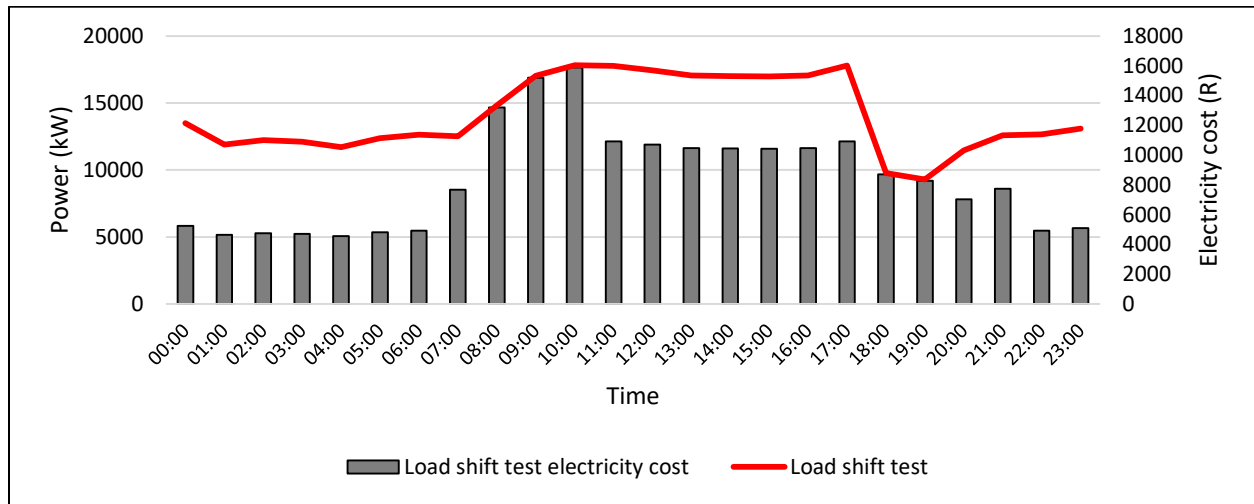

Figure 3 - 30: Mine B weekday average electricity cost calculated from load reduction average power consumption

The implementation of the developed load management strategy is to reduce the system load during the expensive evening peak period of Eskom. This load can be reduced by changing utilisation time of the surface cooling system. Figure 3 - 31 and Figure 3 - 32 shows the utilisation of the baseline and the load reduction test respectively for Mine A cooling system.

Comparing the two charts the utilisation of the system during the expensive evening peak period can be seen. This load has shifted to standard period; ideally, the load should be shifted to the off-peak period. However, this reduction also results in feasible electricity cost savings throughout the year.

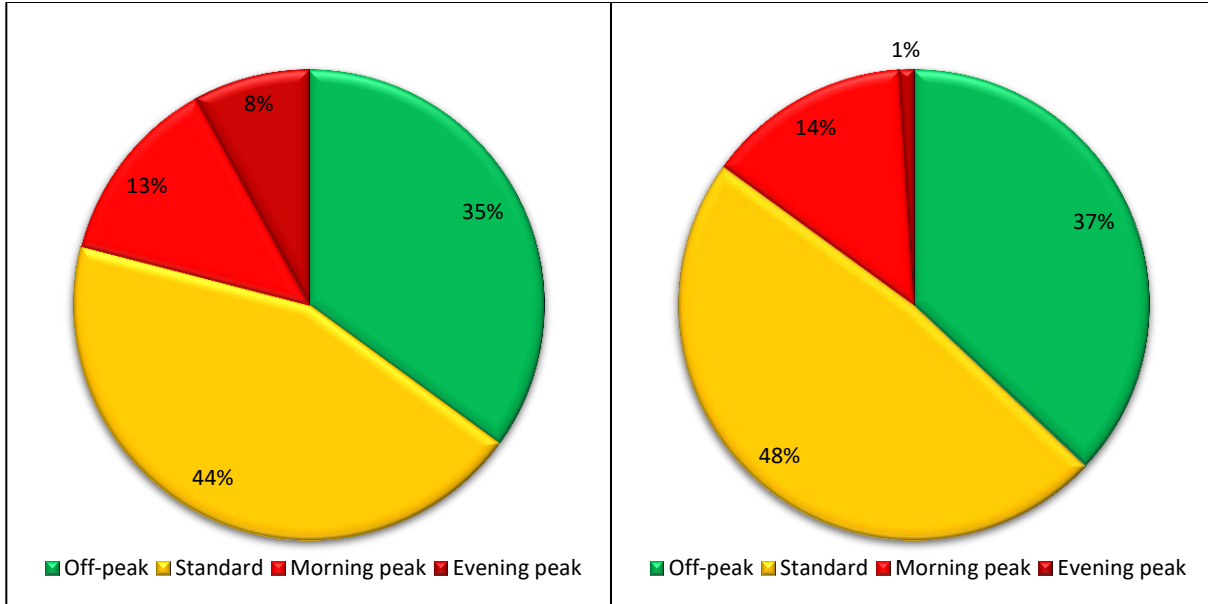

Figure 3 - 31: Mine A surface cooling system baseline utilisation

Figure 3 - 32: Mine A surface cooling system load reduction

The electricity cost comparison of the two periods (baseline and load reduction test) is shown in Figure 3 - 33. From this chart, it can be seen that the electricity cost had been reduced in the evening peak period.

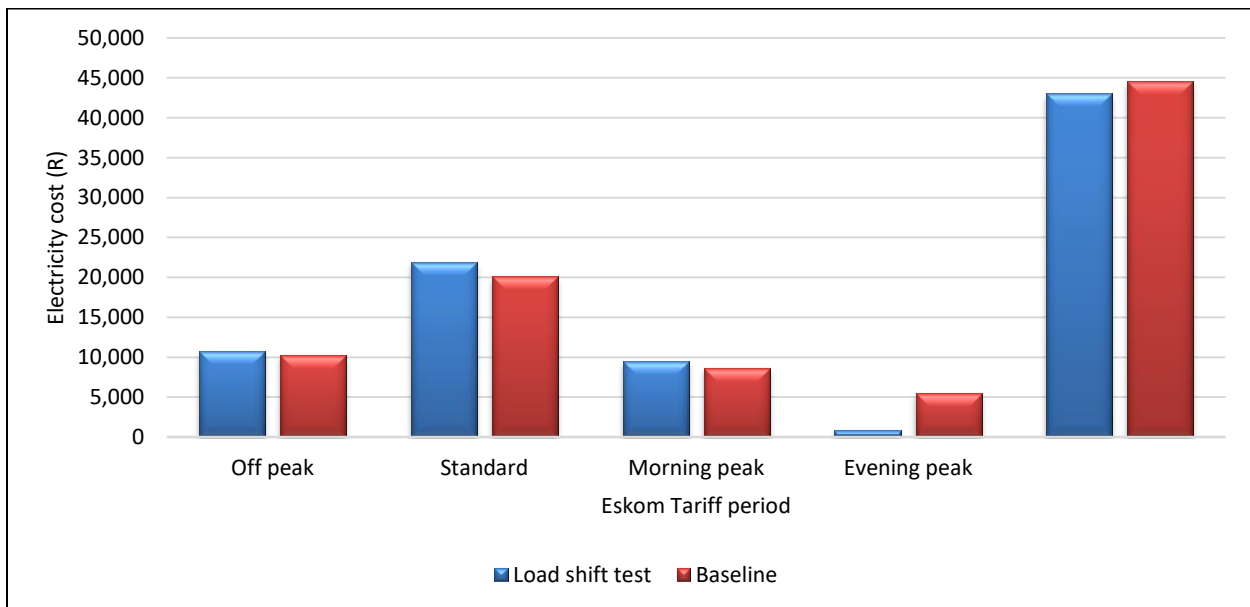

Figure 3 - 33: Mine A average daily electricity cost

Figure 3 - 35 and Figure 3 - 34 show the utilisation of the system for the baseline and the load reduction tests respectively for Mine B. The evening peak utilisation was only reduced by 1%; however, this 1% load reduction resulted in significant electricity cost savings.

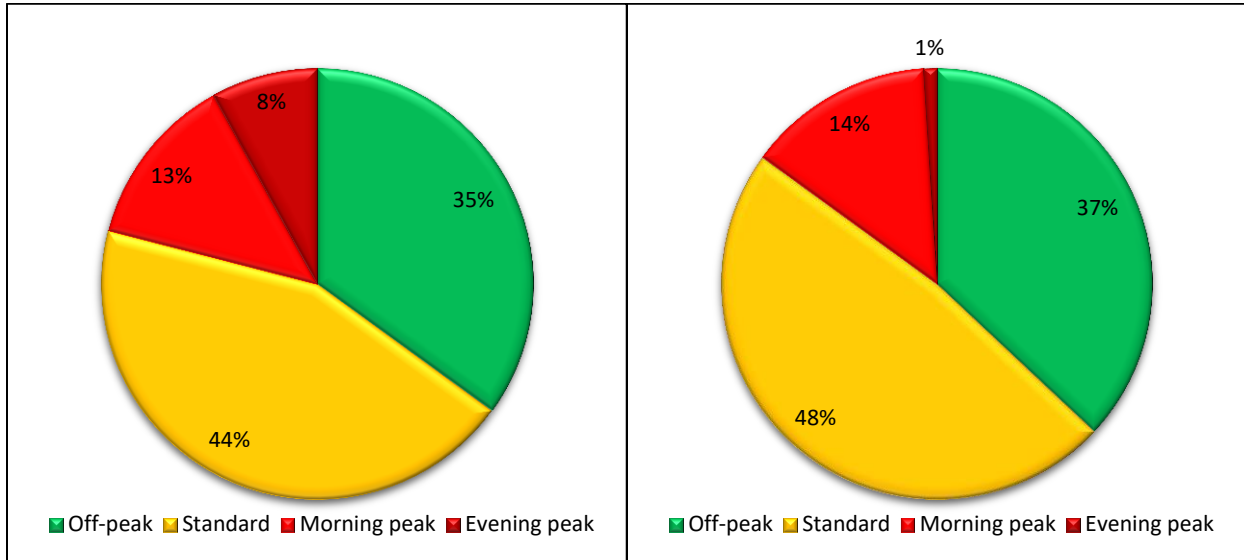

Figure 3 - 35: Mine B surface cooling system baseline

Figure 3 - 34: Mine B surface cooling system load reduction test

The electricity cost comparison of Mine B for the two periods (baseline and load reduction test) is shown in Figure 3 - 36. From this chart, it can be seen that the electricity cost had been reduced in the evening peak period.

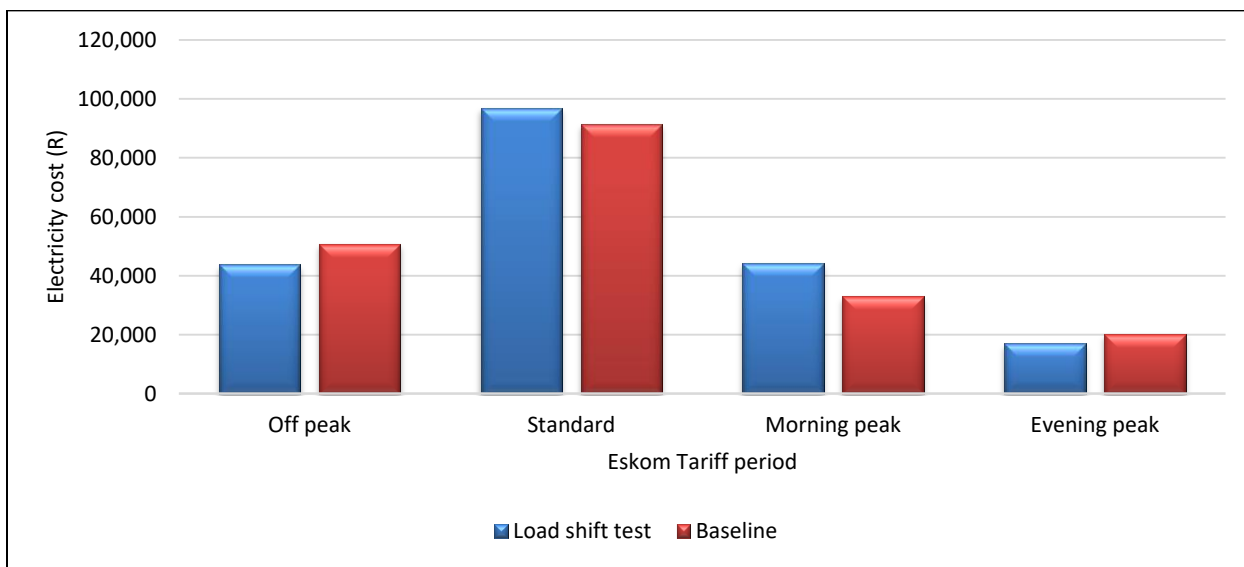

Figure 3 - 36: Mine B average daily electricity cost

3.4 Conclusion

The need to achieve energy efficiency and load management on energy-intensive industries remains crucial. This need to conserve energy has led to many investigations, including this study. In this study, one of the deep-level gold mines energy-intensive systems were investigated, specifically surface cooling systems. This study is motivated by noting in literature that there is still a need to achieve more energy savings on these energy-intensive systems.

This study focuses on the mine surface cooling system because it presents an opportunity to achieve more electricity cost savings. This opportunity comes by the favourable evening ambient conditions which reduce the cooling demand. And again, in most gold mines, the Eskom evening peak period is the blasting period. A versatile load management strategy was developed to assist in reducing the load of the surface cooling system in the evening peak period. This strategy is applicable to closed and semi-closed loop mine surface cooling systems.

The strategy is to switch off the surface cooling system equipment, i.e., fridge plants, evaporator pumps, condenser pumps, condenser cooling fans, and BAC fans, in the evening peak period during weekdays. During this period, the underground conditions, i.e., temperatures and RH will be closely monitored. The underground temperatures of the stations/waiting areas must not exceed the maximum limit of 25.5°C WB.

Two case studies were used to verify the developed strategy. Case Study 1, Mine A with a closed loop and Case Study 2, Mine B with semi-closed loop surface cooling system. Both these case studies surface cooling systems have an existing DSM initiative. VSDs are installed on the systems to optimise the flow rates to achieve energy efficiency. The strategy was verified by conducting load reduction tests on both case studies. Portable standalone temperature and RH sensors were installed underground to measure the underground conditions before and after the load reduction tests. The power data for both periods were also logged simultaneously.

A week after the sensors were installed to compile the normal operation baseline, the load reduction tests commenced. All the fridge plants, condenser pumps, and condenser cooling fans were switched off during the evening peak period. The mine personnel did not allow the BACs' fans to be switched off due to ventilation purposes for both mines. The evaporator pumps of Mine B were not switched off because the system is a semi-closed loop system, these pumps supply water to the ice plant cooling towers to prevent surging of the plants.

The baseline of underground temperatures were compared to that of the test measured on the same point. The difference between the baseline temperatures and the load reduction test temperatures was below 1°C WB. 2.8 MW and 1.8 MW load was shifted from Mine A and Mine B respectively out of the evening peak period. 2.8 MW load reduction has an annual estimated electricity cost savings of R1.5 million, and 1.8 MW is estimated to be R900 000 using 2016/2017 Eskom Megaflex Tariffs. Switching off the surface cooling system did not adversely affect the underground environment conditions, hence the developed load management strategy can be considered to be successful. This strategy is implemented in the next chapter and the results are discussed.

4. Implementation of strategy and results

The load management strategy that was developed and verified in Chapter 3 is implemented and validated in this chapter.



Chapter 4

⁷Thabiso S. Moropa personal photo. Mine A evaporator pumps

Chapter 4: Implementation of strategy and results

4.1 Introduction

The development of the load management strategy was discussed in Chapter 3. Load reduction tests were conducted to verify the developed strategy. The results of the tests show that the strategy is feasible and can be implemented for validation. The strategy is versatile and can be implemented on closed and/or semi-closed loop mine surface cooling systems. The validation of this strategy is discussed in this chapter.

The two deep-level gold mines that were used to verify the strategy in Chapter 3: Mine A with a closed loop and Mine B with a semi-closed loop surface cooling system, will again be used in the two case studies to validate the developed strategy. The post-implementation results for both case studies are presented in this chapter. Aspects and challenges that were encountered during implementation phase are also discussed.

4.2 Case Study 1 – Closed loop system

The EnMS that was described in Chapter 3 will be used to execute the developed load management strategy. The Mine A surface cooling system site layout, as shown in Figure 4 - 1, is used to create the software platform (EnMS). The system operation, together with the surface cooling system layout, was previously discussed in Chapter 3. The cooling system of Mine A includes the following:

- four Howden fridge plants,
- five evaporator pumps,
- five transfer pumps,
- eight BAC fans (four on each BAC stage),
- five condenser pumps, and
- four condenser fans.

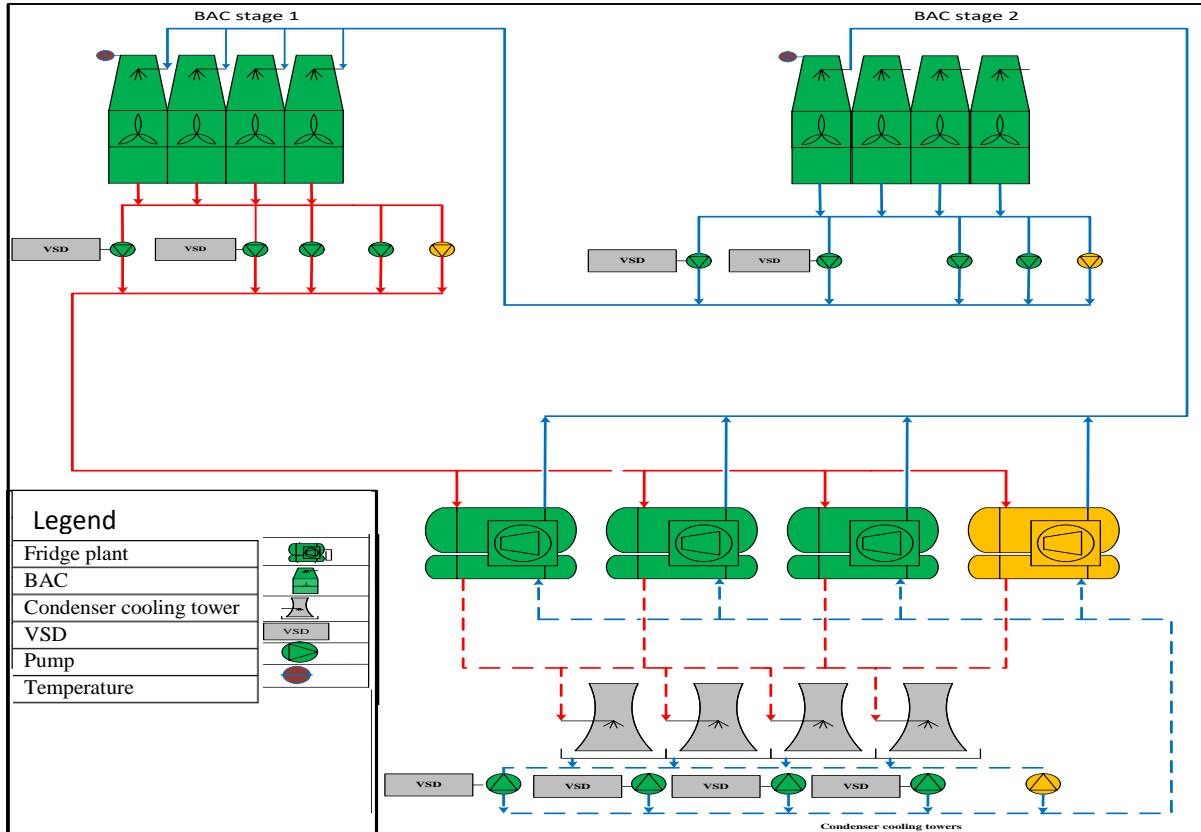

Figure 4 - 1: Mine A surface cooling system

The three underground levels (95, 100 and 110) that were taken into consideration during the load reduction tests are again used as the temperature measuring points to validate. *Greasing*⁸ temperature and RH permanent sensors, and Schmidt airflow sensors, were installed on each level.

The communication between the permanent sensors and the SCADA was established through the PLCs. The weather station on surface is used to monitor and record ambient conditions. Figure 4 - 2 illustrates the Mine A EnMS platform layout for the surface cooling system. And the communication between the SCADA and the EnMS is established through OPC, as previously discussed in Chapter 3. The SCADA development to integrate the EnMS with the system equipment also form part of the implementation costs.

⁸ Greasing is the temperature and relative humidity sensor name from manufacturer

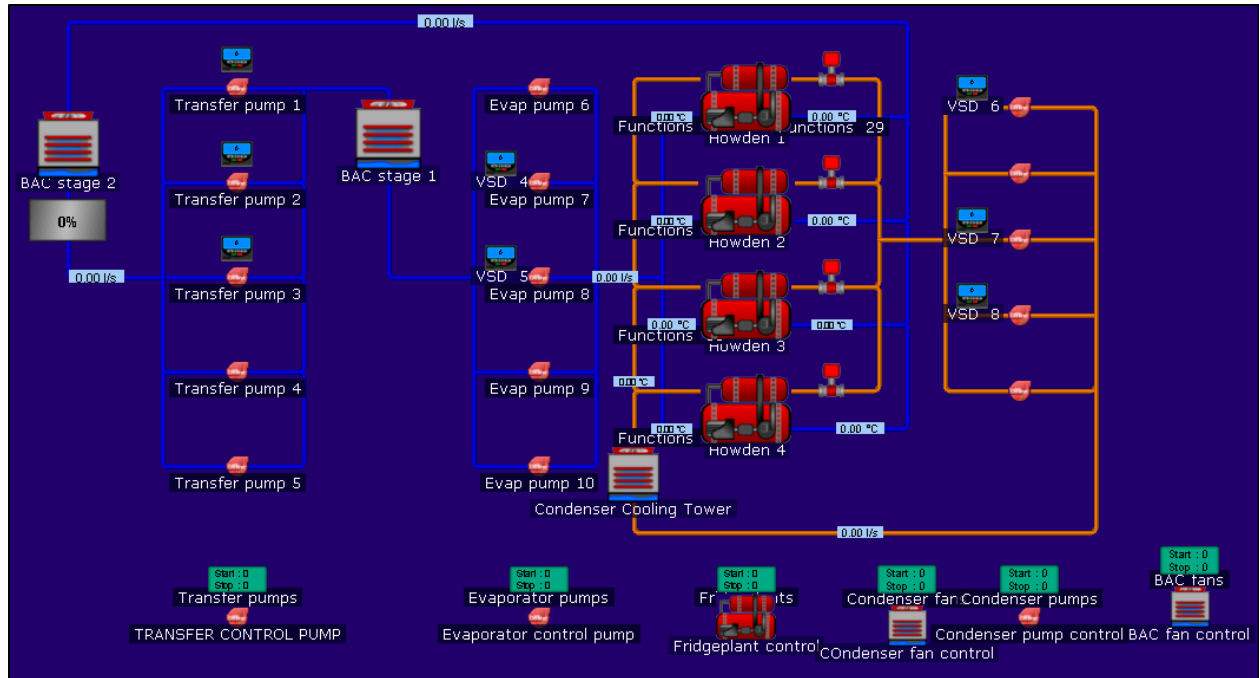

Figure 4 - 2: Mine A surface cooling system layout - Closed loop configuration

The developed load management strategy incorporates the stopping and starting of the surface cooling system equipment while measuring and monitoring the underground temperatures. The measured temperature readings from the installed sensors and the total power consumption of the system are presented in this section. The results illustrate the intervention effect of the implemented strategy.

When the surface cooling system equipment is switched off, there is a distinct increase in temperature during the evening peak period. However, this increase remains below the maximum set WB temperature limit of 25.5°C WB; therefore, there is no need to start the cooling system during the evening peak period. Figure 4 - 3, Figure 4 - 4 and Figure 4 - 5 show the temperature profiles of 95, 100 and 110 levels respectively. More than three months of data post-implementation of the strategy was used to compile these profiles.

The 95 level main shaft WB temperature increased steadily by an average of 0.7°C WB over the two-hour period. Figure 4 - 3 shows the WB temperature profiles of the 95 level. It can be seen that the temperature immediately decreases after 20:00 when the surface cooling system is

operated again to meet the cooling demand. It took approximately four hours to normalise the underground temperatures at this level. However, the temperatures did not exceed the maximum limit of 25.5°C WB.

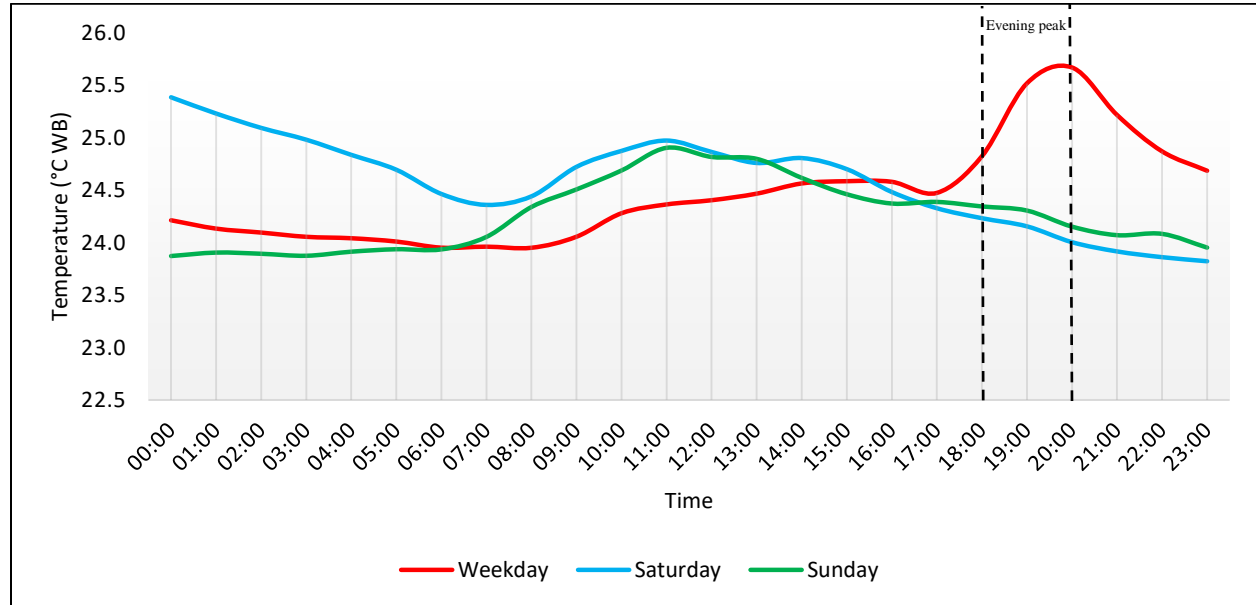

Figure 4 - 3: 95 level main shaft – WB outlet temperatures

Table 4 - 1 shows the temperatures summary of 95 level, three months after the implementation. There is an average of 25.2°C WB temperature in the evening peak period during weekdays. However, this temperature does not exceed the maximum set limit of 25.5°C WB.

Table 4 - 1: Temperature summary of 95 level main shaft for Mine A

	Weekday (°C WB)	Saturday (°C WB)	Sunday (°C WB)
Minimum	24.0	23.8	23.9
Average	24.5	24.6	24.3
Maximum	25.7	25.4	24.9
Average (18:00 – 20:00)	25.2	24.2	24.3

The WB temperature at 100 level also increased during the Eskom evening peak period. The temperature increased by an average of 0.9°C WB over the two hours. The WB temperature profiles of 100 level are shown in Figure 4 - 4. The air WB temperature is on the y-axis and time

on the x-axis. It also took approximately four hours to normalise the underground temperatures at this level. However, the temperatures did not exceed the maximum limit during the high demand period.

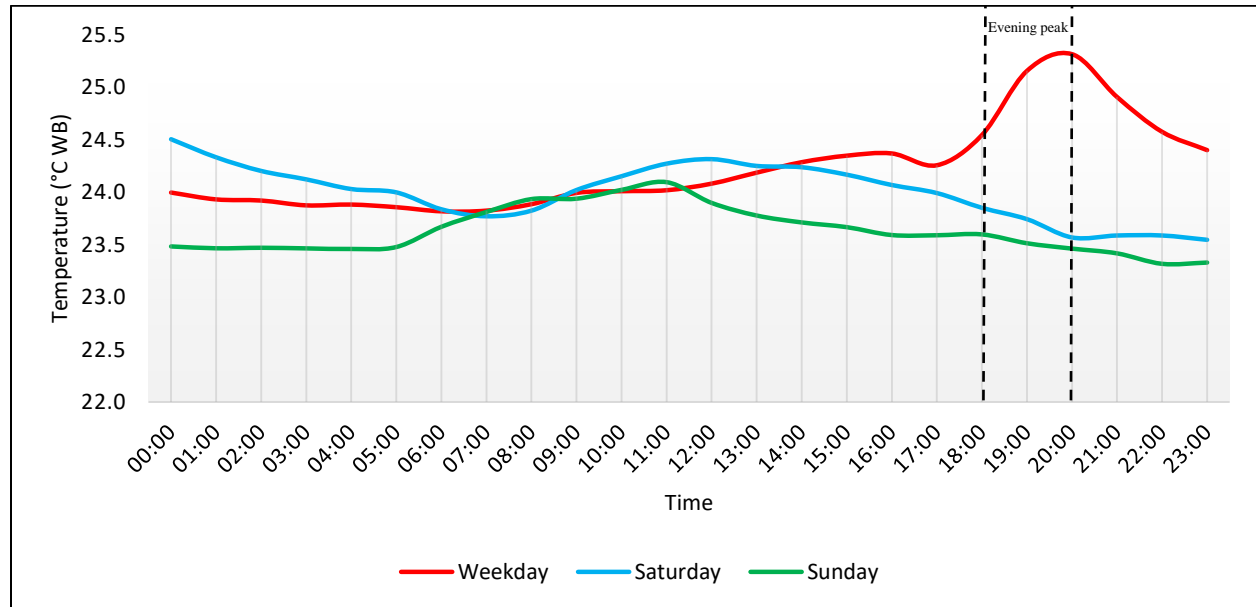

Figure 4 - 4: 100 level main shaft – WB outlet temperatures

Table 4 - 2 shows the temperatures summary of 100 level, three months after implementation. There is an average of 25.2°C WB temperature on this level in the evening peak period during weekdays. This temperature does not exceed the maximum set limit of 25.5°C WB as well.

Table 4 - 2: Temperature summary of 100 level main shaft for Mine A

	Weekday (°C WB)	Saturday (°C WB)	Sunday (°C WB)
Minimum	23.8	23.6	23.3
Average	24.2	24.0	23.6
Maximum	25.3	24.5	24.1
Average (18:00 – 20:00)	24.9	23.8	23.6

There is temperature increase of 0.53°C WB with an average difference between the baseline and the actual period of 0.9°C WB on 110 level. Figure 4 - 5 shows the temperature trends at

110 level. The maximum set limit of 25.5°C WB is being reached during the evening peak period, however, there are some days where this limit was surpassed. On such days, one fridge plant was started to decrease the temperatures. It also takes approximately four hours for normalisation.

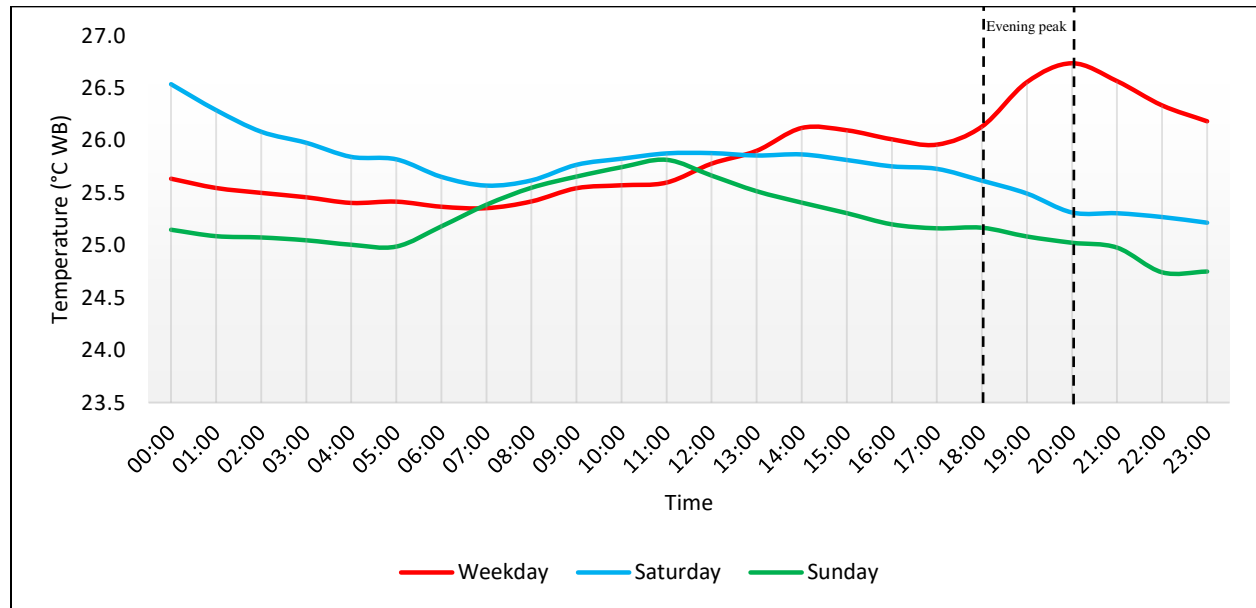

Figure 4 - 5: 110 level main shaft – WB outlet temperature

Table 4 - 3 shows the temperature summary of 110 level three months after implementation. There is an average of 26.4°C WB temperature during the evening peak period during weekdays. However, this temperature exceeded the maximum set limit of 25.5°C WB. This 26.4°C WB is surpassed the maximum limit of 25.5°C WB by 0.9°C WB. This difference is 3.3% more than the maximum set limit; however, this difference is less than 5%.

The mine personnel did not complain about this temperature because at the lower mining levels, the maximum set limit is 27.5°C WB. Therefore, this temperature is allowable and the surface cooling system can continually be switched off during the evening peak period to achieve load reduction which results in electricity cost savings.

Table 4 - 3: Temperature summary of 110 level main shaft for Mine A

	Weekday (°C WB)	Saturday (°C WB)	Sunday (°C WB)
Minimum	25.4	25.2	24.7
Average	25.8	25.8	25.2
Maximum	26.7	26.5	25.8
Average (18:00 – 20:00)	26.4	25.6	25.1

The 24-hour power profiles of the surface cooling system after implementation can be seen in Figure 4 - 5. An average of 1.8 MW load was shifted from the evening peak period. The profiles were compiled from three months period worth of data. The load shifting during the evening peak period on this mine continues and the savings are sustainable. One of the reasons behind sustainable load reduction savings is through training of the control room operators with regard to the use of the EnMS.

As stipulated in Chapter 2, Eskom Tariff structures billing according to the TOU and season. Winter Tariffs are more expensive compared to summer. The cooling system demand depends on each season; the cooling demand is higher in summer than it is in winter. The electricity cost savings of this system are estimated to be R900 000 annually based on the 2016/2017 Eskom Tariffs.

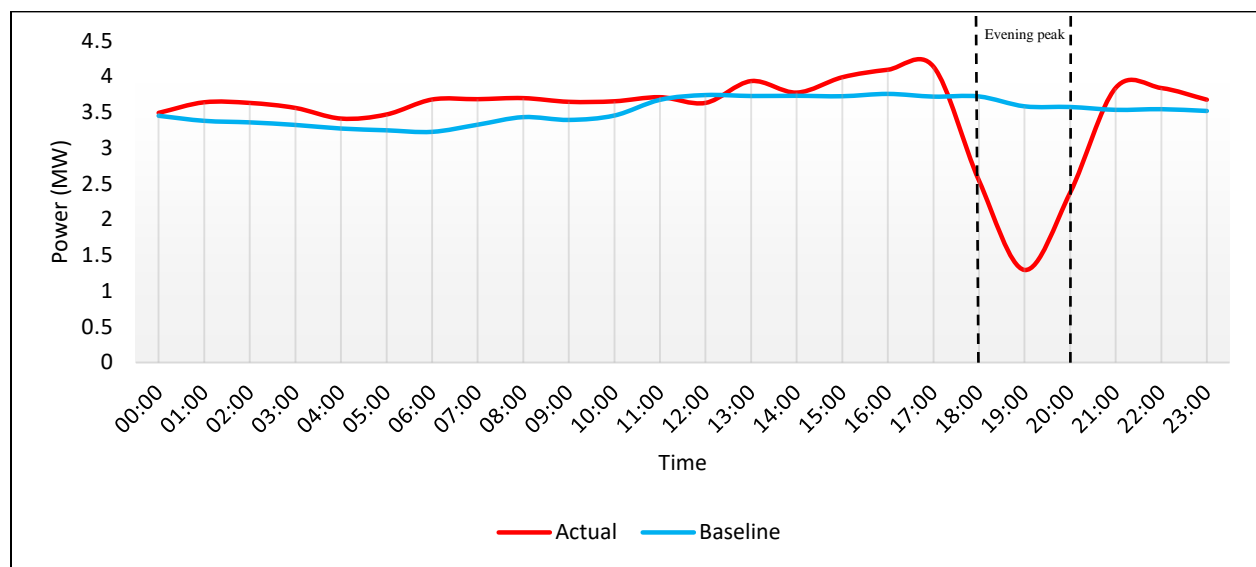

Figure 4 - 6: Mine A power profiles after implementation

Figure 4 - 7 and Figure 4 - 8 show the electricity cost of the baseline and the actual average daily power profiles respectively. The electricity costs of the peak periods are higher than other times of the day, as mentioned previously. The figures below show the effect of the implemented strategy on the electricity costs. The power consumption is illustrated on the primary y-axis and the electricity costs is on the secondary y-axis, and the time is on the x-axis.

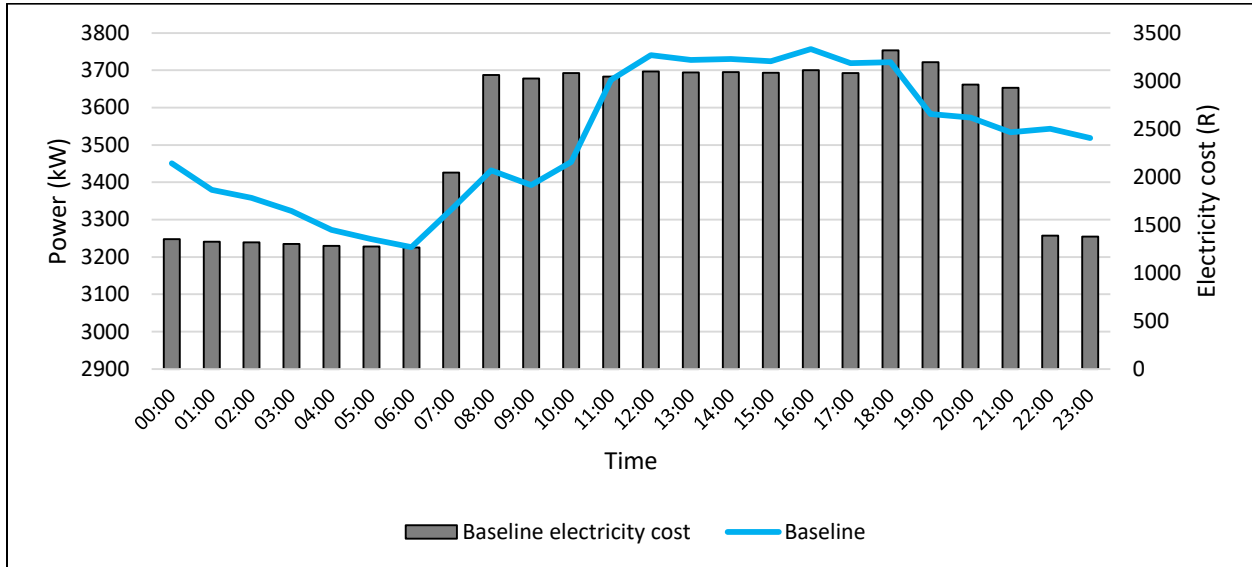

Figure 4 - 7: Mine A weekday average electricity cost calculated from average baseline power consumption prior-implementation

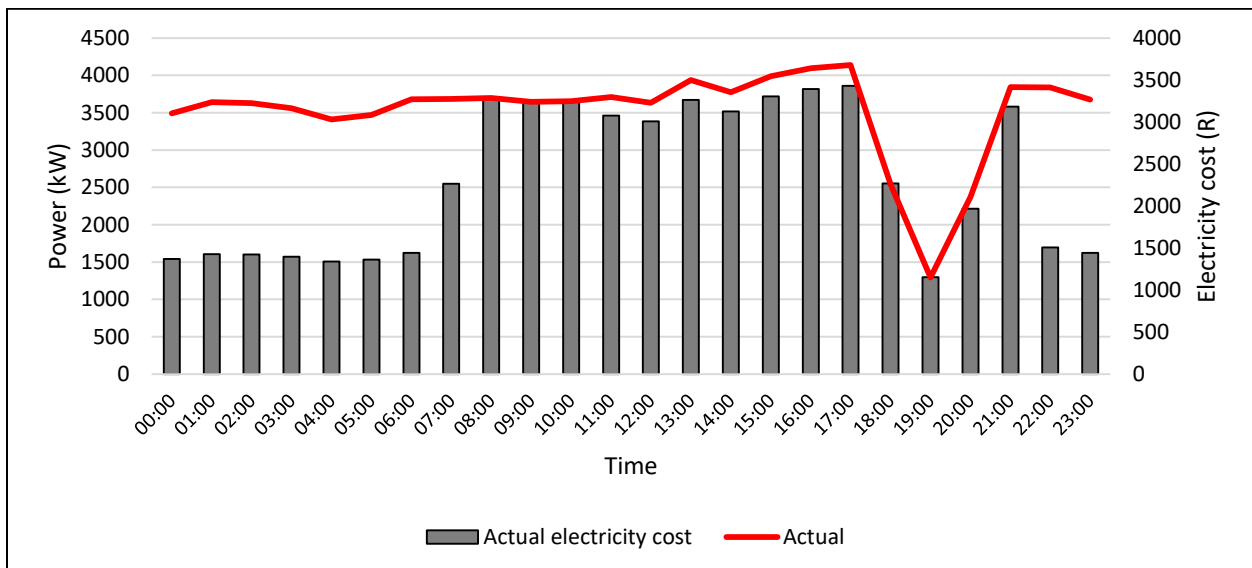

Figure 4 - 8: Mine A weekday average electricity cost calculated from average actual power consumption post-implementation

Implementing the developed load management strategy reduces the load of the system during the expensive evening peak period. Figure 4 - 9 and Figure 4 - 10 show the utilisation of the system for the baseline and the actual respectively for Mine A. It can be seen that the actual utilisation of the system during the expensive evening peak period is lower compared to the baseline utilisation. The load is shifted out of the evening peak to other times of the day, i.e., off-peak and standard period. There is a 4% reduction in the evening load of the system. This evening load reduction results in electricity cost savings.

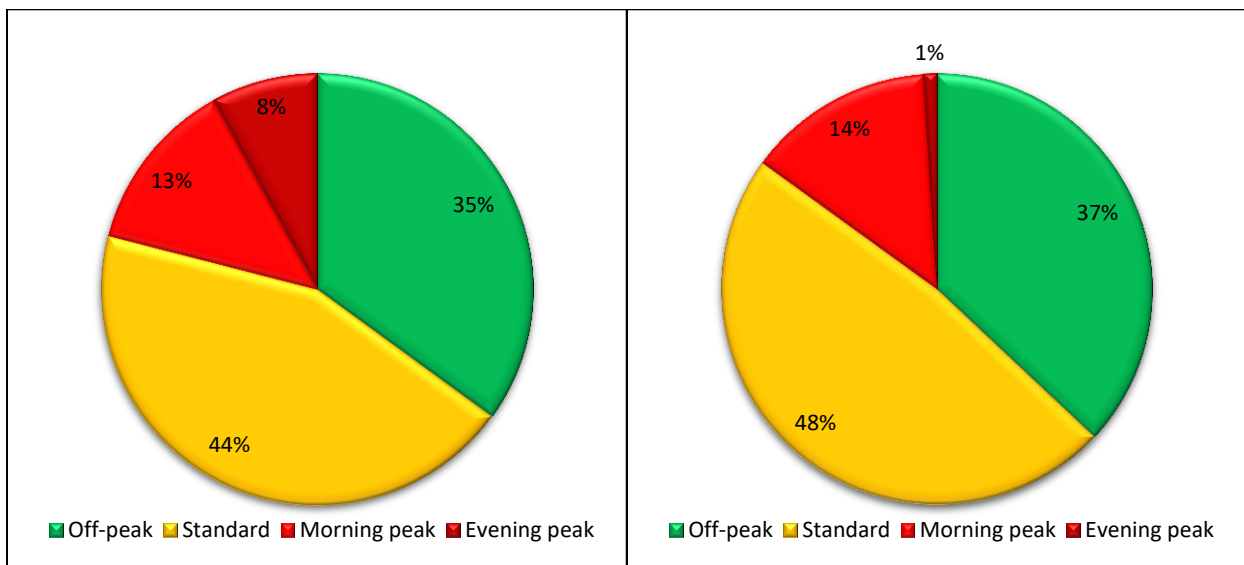

Figure 4 - 10: Mine A surface cooling system baseline

Figure 4 - 9: Mine A surface cooling system actual

Comparing the electricity cost of the two period periods, i.e., the baseline and the actual, a distinct difference in the evening cost can be seen. This comparison is shown in Figure 4 - 11 below. The 24-hour electricity cost data can be found in Appendix 3.

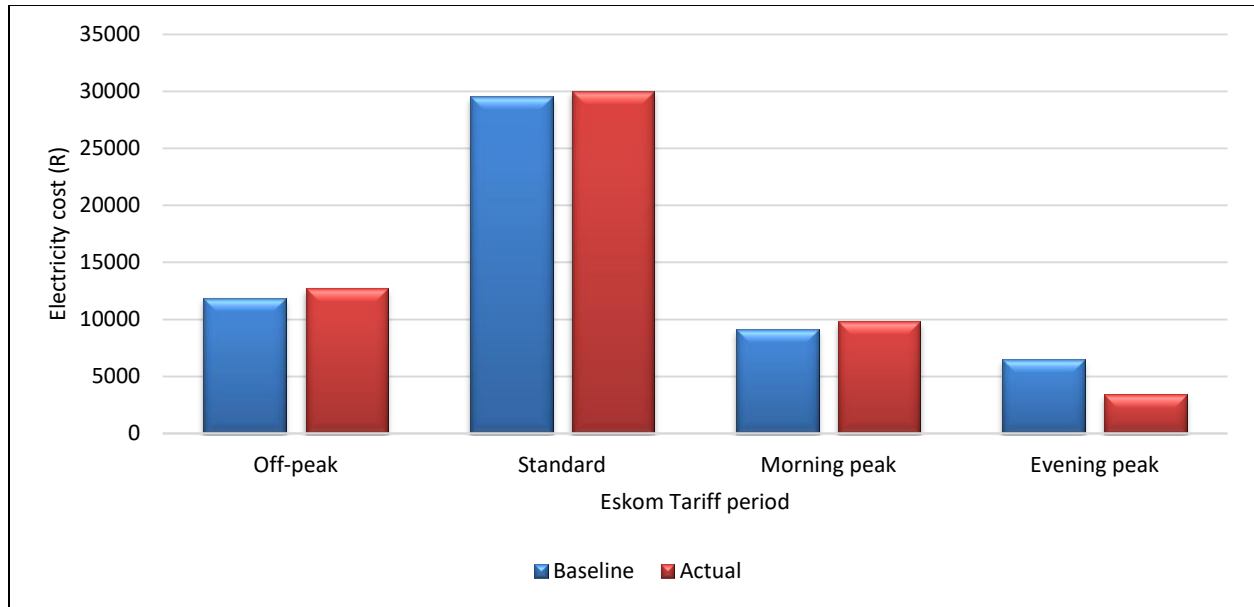

Figure 4 - 11: Mine A average daily electricity cost

4.3 Case Study 2 – Semi-closed loop system

The EnMS system that was implemented at Mine A, was also implemented at Mine B to execute the developed load management strategy. The Mine B site layout shown in Figure 4 - 12 was used to develop the simulation platform. The simulation platform layout for Mine B is shown in Figure 4 - 13. As explained in Chapter 3, Mine B has two sets of fridge plants, i.e., the Top and the Pamodzi fridge plants. However, the strategy is implemented on the Pamodzi circuit with the following infrastructure:

- four Pamodzi fridge plants,
- four evaporator pumps,
- four condenser pumps,
- five BAC fans, and
- four condenser fans.

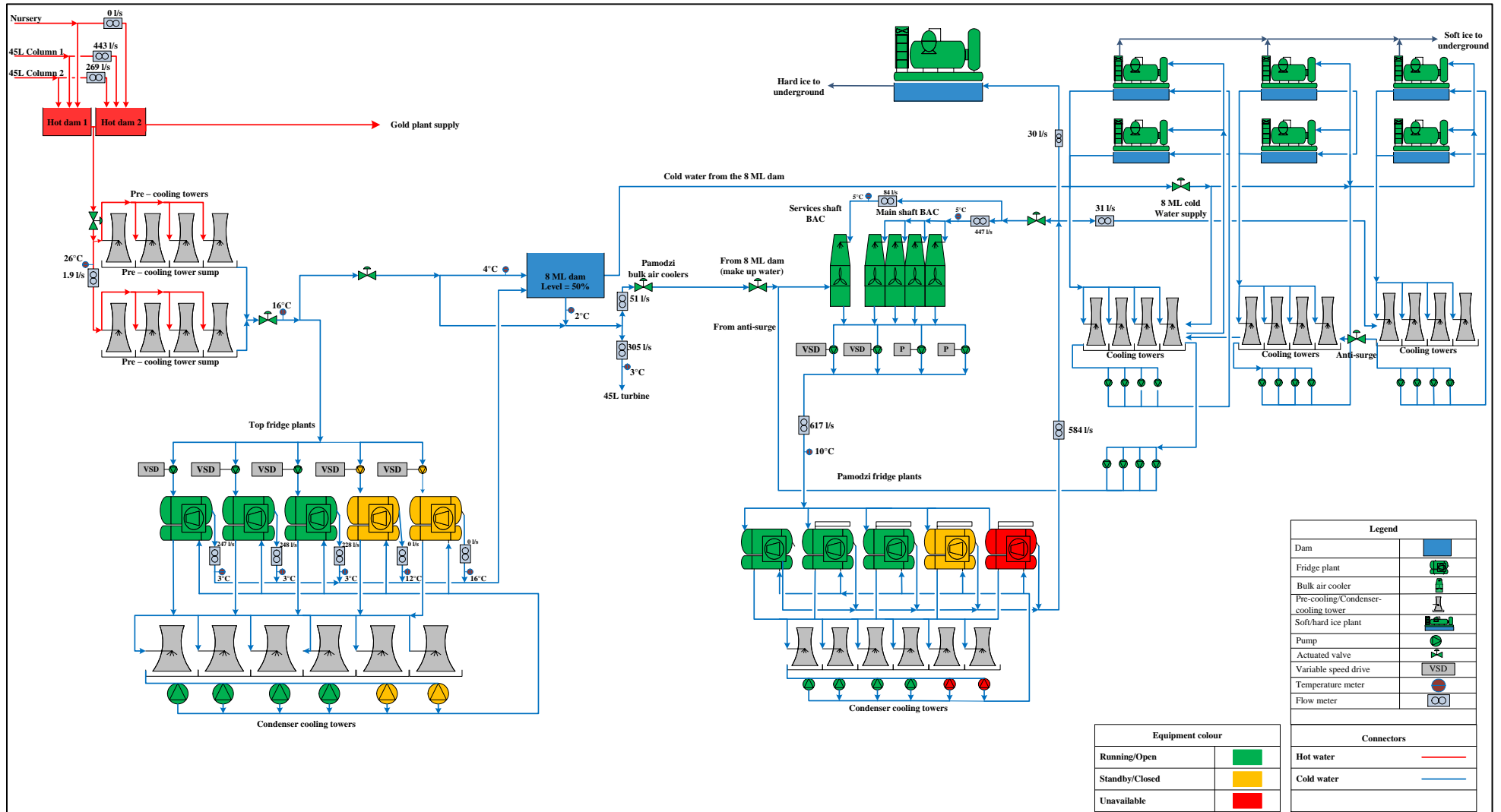

Figure 4 - 12: Mine B site layout

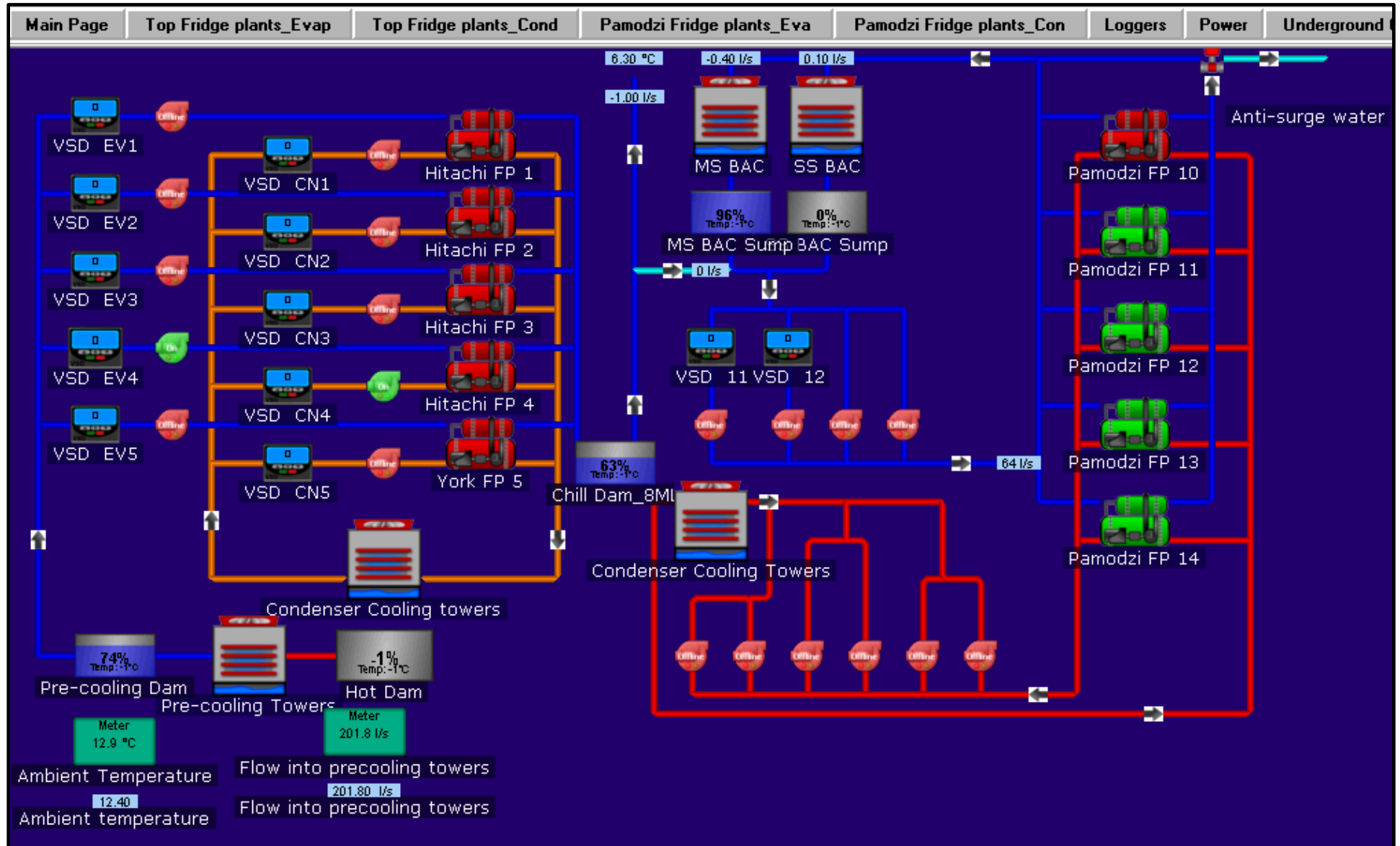

Figure 4 - 13: Mine B surface cooling system layout - Closed loop configuration

The Pamodzi fridge plants supply cold water to BACs and to the anti-surge, which supplies cold water to the soft and to the hard ice plants. When the Pamodzi fridge plants are switched off, the anti-surge water temperature increases at a high rate. This increase in the water temperature is caused by the circulation (friction) of water through the evaporator circuit, while the Pamodzi fridge plants are off.

When this water temperature increases, it forces the start-up of the Pamodzi fridge plants to produce acceptable water temperature to the ice plants. The cost and energy savings are greatly affected when the Pamodzi fridge plants are switched on during the evening peak period. Figure 4 - 14 illustrates the water temperature increase that occurred during the implementation phase when the water was circulated.

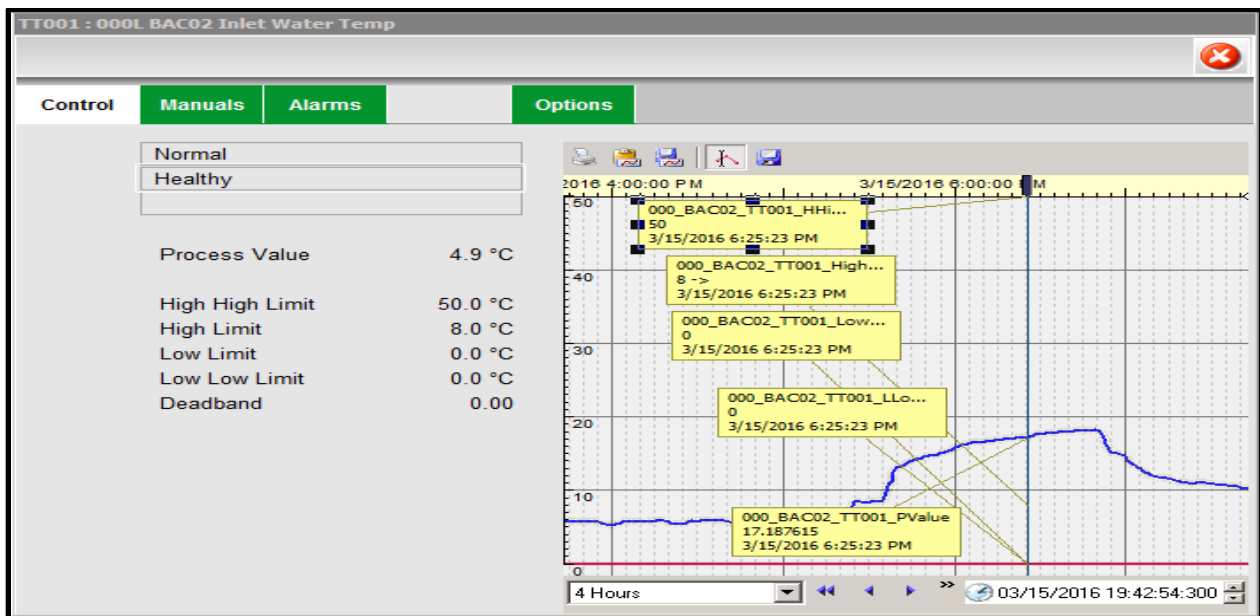

Figure 4 - 14: Mine B - Anti-surge water temperature profile (taken from the Mine B SCADA)

It can be seen that the water temperature increased at a high rate for the first 10 minutes, from 7.0°C to ±17.0°C. When the water reaches 15.0°C, it increases slowly at a steady pace. After starting the Pamodzi fridge plants, the water temperature dropped immediately. It took ±10 minutes to get this water temperature back to the set point. It is important to keep this water temperature as low as possible because when the temperature increases, the hard ice plants trip; and it is must that the hard ice plants receive continuous cold water to run consistently.

The developed load management strategy was successfully implemented at Mine A by only monitoring the underground conditions, i.e., temperature and relative humidity. This monitoring was not sufficient at Mine B, therefore, the strategy had to be adjusted to suit Mine B's system.

As already mentioned, Mine B has two sets of fridge plants: Pamodzi fridge plants and Top fridge plants. The Pamodzi fridge plants supply cold water to the BACs, the hard ice plants and the anti-surge. The Top fridge plants feed cold water to an 8 ML dam; which is then sent underground for mining operations. There is a pipeline from the 8 ML dam connected to the hard ice plants system and the anti-surge. The water flow from the 8 ML dam to the hard ice plants and anti-surge is only allowed during winter when the Pamodzi fridge plants are not in operation during winter and/or if there are problems with the Pamodzi cold water supply.

The pipeline from the 8 ML dam to the anti-surge was used to aid in making changes to the developed load management strategy. The anti-surge valve is being closed while the 8 ML dam valve is being opened to allow cold water flow to supply the hard ice plants and the anti-surge during the evening peak period. After the peak period, the anti-surge valve is opened and 8 ML dam valve is closed. The evaporator pumps circulate the water through the BACs but not to the hard ice plants and the anti-surge.

Figure 4 - 15 and Figure 4 - 16 show the 8 ML dam level before and after implementation respectively. It can clearly be seen from the figures that the re-routing for the two hours has minor impact on the dam level. However, after implementation, the dam level clearly decreased during the evening peak period and increased afterwards. The dam level is within normal operational range, hence this re-routing can be considered successful.

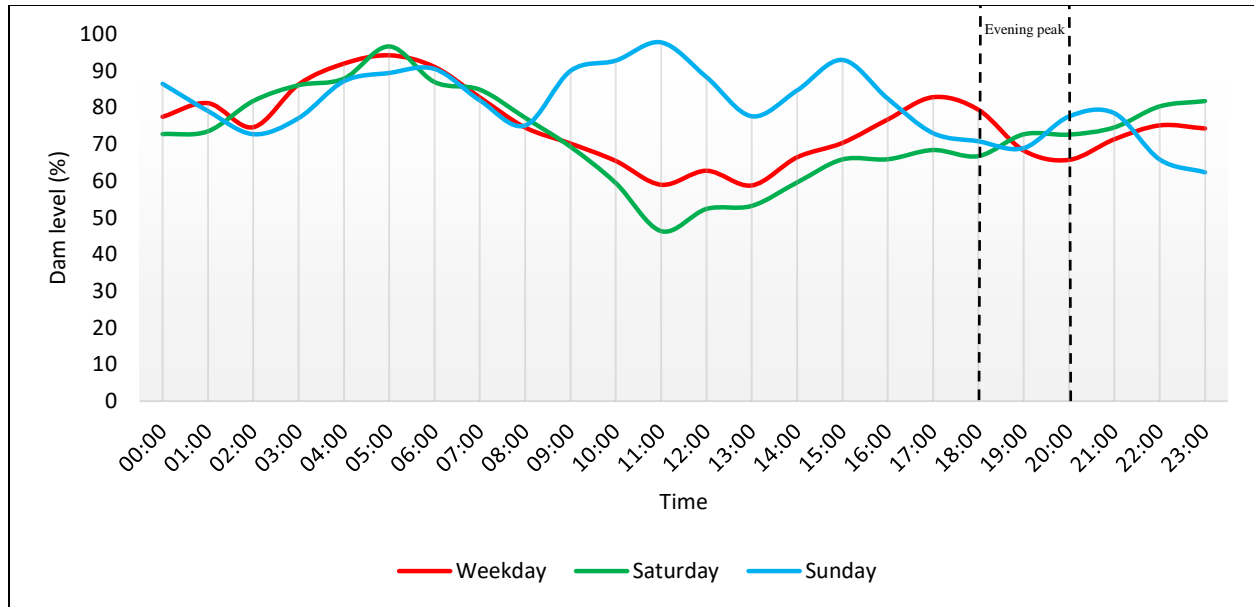

Figure 4 - 15: The 8 ML dam level pre-implementation

Table 4 - 4 shows the 8 ML dam level summary level before implementation. There was an average of 74% of the 8 ML dam in the evening peak period during weekdays. This average dam level is used as a baseline for this dam to be able to implement the changes on the strategy.

Table 4 - 4: 8 ML dam level summary before implementation at Mine B

	Weekday (%)	Saturday (%)	Sunday (%)
Minimum	58.8	46.4	62.4
Average	75.1	72.4	81.0
Maximum	94.3	96.7	97.8
Average (18:00 – 20:00)	73.9	69.8	69.9

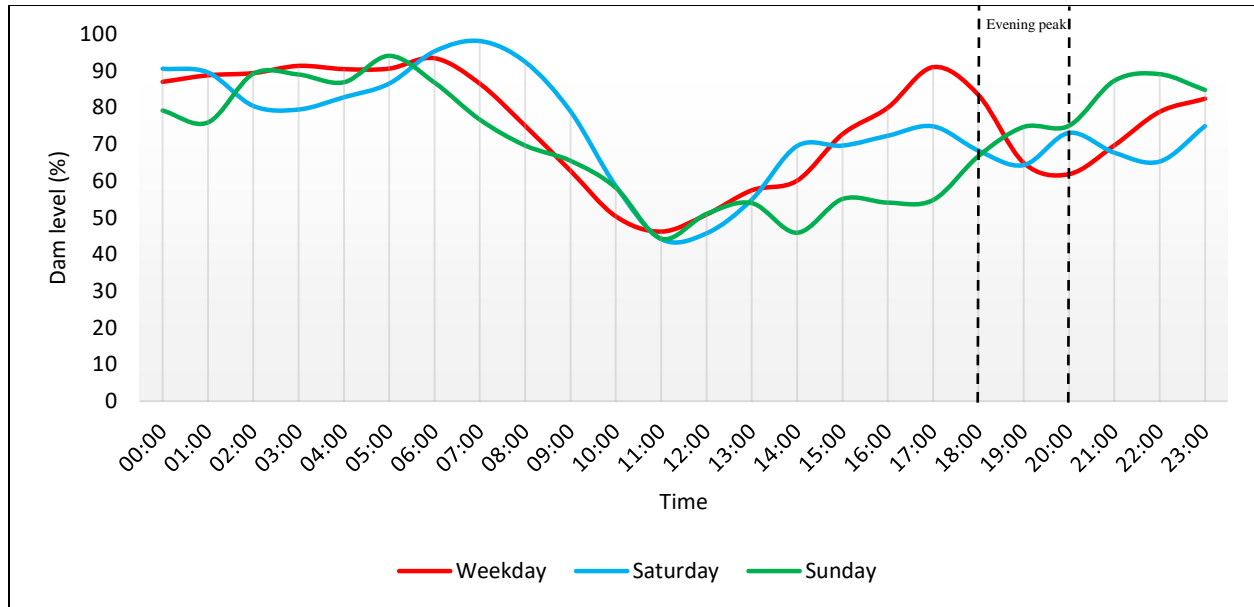

Figure 4 - 16: The 8 ML dam level post-implementation

Table 4 - 5 shows the 8 ML dam level summary level after implementation. There is an average of 74.2% during the evening peak period. This average is approximately the same as the average dam level before implementation, $\pm 74\%$. This clearly shows that the rerouting has little impact on the 8 ML dam level.

Table 4 - 5: 8 ML dam level summary levels after implementation at Mine B.

	Weekday (%)	Saturday (%)	Sunday (%)
Minimum	46.2	44.2	44.3
Average	75.3	74.1	71.2
Maximum	93.5	98.2	94.1
Average (18:00 – 20:00)	74.2	66.3	70.8

Figure 4 - 17 shows the inlet air temperature profiles of the underground BACs on 84 level after implementation. Three months’ worth of data was retrieved from the installed permanent sensor and was used to compile these profiles. The temperature after implementation increases during the evening peak period but it remains within the mine safe operating conditions.

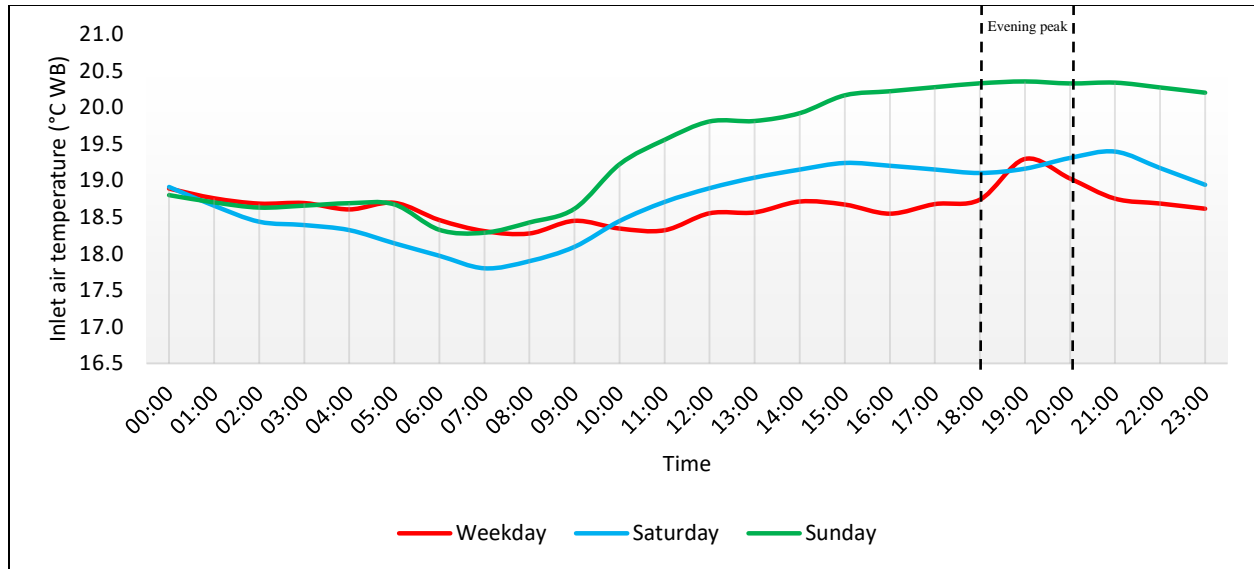

Figure 4 - 17: Underground BACs inlet air temperature post-implementation

Table 4 - 6 shows the underground BACs inlet air temperature on 84 level three months after implementation. There is an average of 19.0°C WB temperature on this level in the evening peak period during weekdays. This temperature does not exceed the maximum set limit of 25.5°C WB.

Table 4 - 6: Underground BACs inlet air temperature before implementation at Mine B.

	Weekday (°C WB)	Saturday (°C WB)	Sunday (°C WB)
Minimum	18.3	17.8	18.3
Average	18.6	18.7	19.4
Maximum	19.3	19.4	20.4
Average (18:00 – 20:00)	19.0	19.1	20.3

The total refrigeration system power of Mine B was used as a baseline, as stated in Chapter 3. The power profiles of the surface cooling system after implementation can be seen in Figure 4 - 18. Three months after implementation, an average of 2.7 MW load is reduced during the evening peak period with annual cost savings of R1.4 million. The load reduction from this surface cooling system is continually being achieved in the Eskom’s evening peak period.

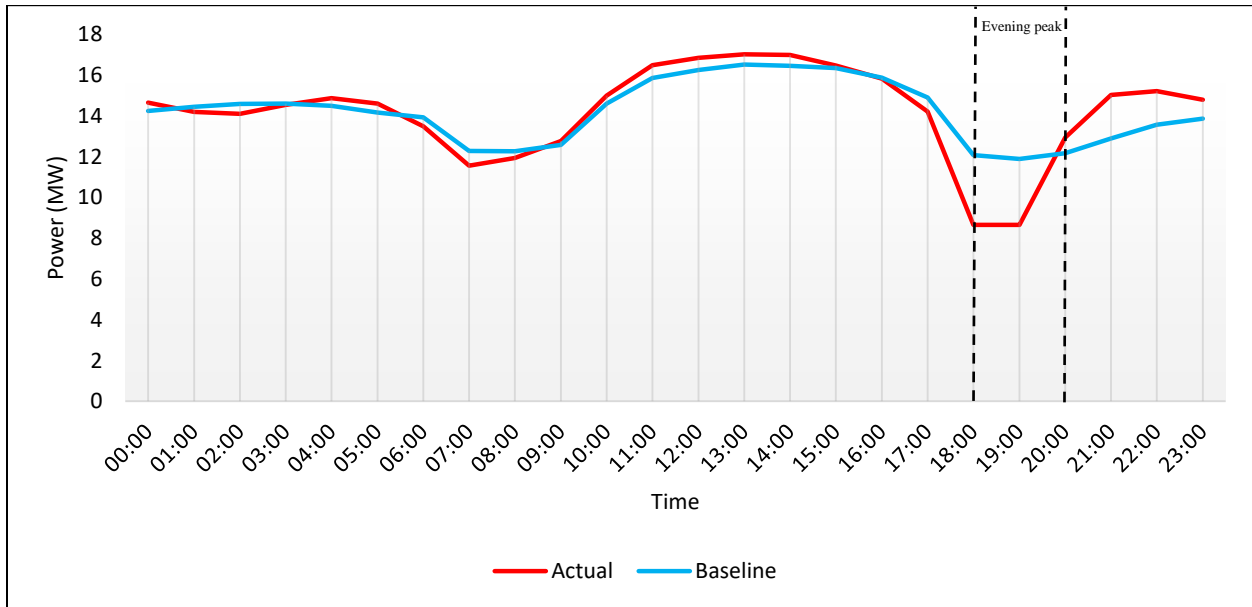

Figure 4 - 18: Mine B power profile after implementation

Figure 4 - 19 and Figure 4 - 20 illustrate the average electricity cost of the baseline and the actual after implementation power profiles respectively. The evening peak periods have higher electricity costs because of the Eskom Megaflex tariff structure, as previously explained.

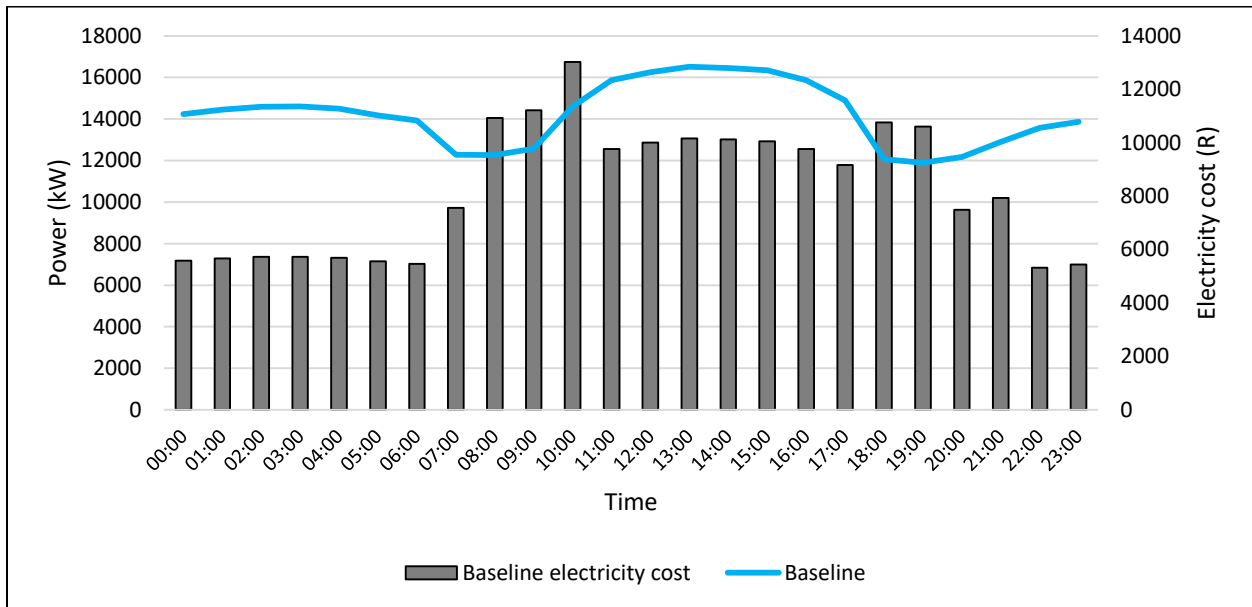

Figure 4 - 19: Mine B weekday average electricity cost calculated from average baseline power consumption prior-implementation

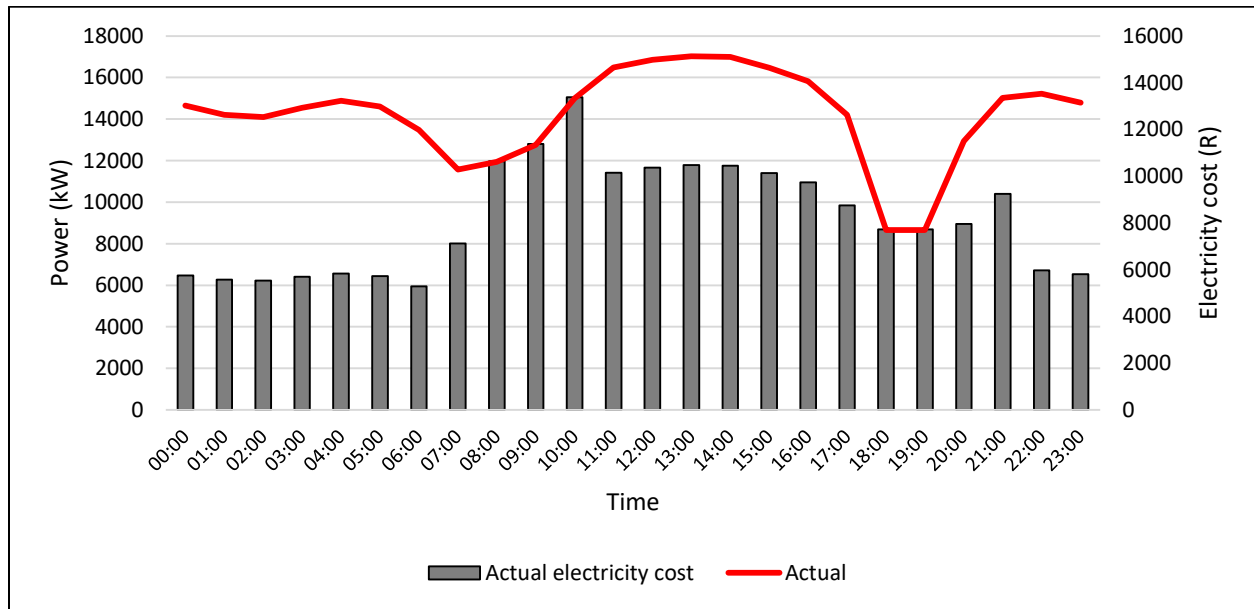

Figure 4 - 20: Mine B weekday average electricity cost calculated from average actual power consumption post-implementation

The implementation of the developed load management strategy is to achieve load reduction on the surface cooling system during the Eskom’s expensive evening peak period. By changing the surface cooling system’s time of utilisation, this load reduction in the evening peak period can be achieved.

Figure 4 - 21 and Figure 4 - 22 show the surface system’s utilisation of the baseline and the actual for Mine B. It can be seen that the system’s actual utilisation is lower compared to that of the baseline during the expensive evening peak period. The load from the system’s actual utilisation has been shifted to cheaper times of the day, i.e. standard and off period. This load reduction results feasible electricity cost savings throughout the year.

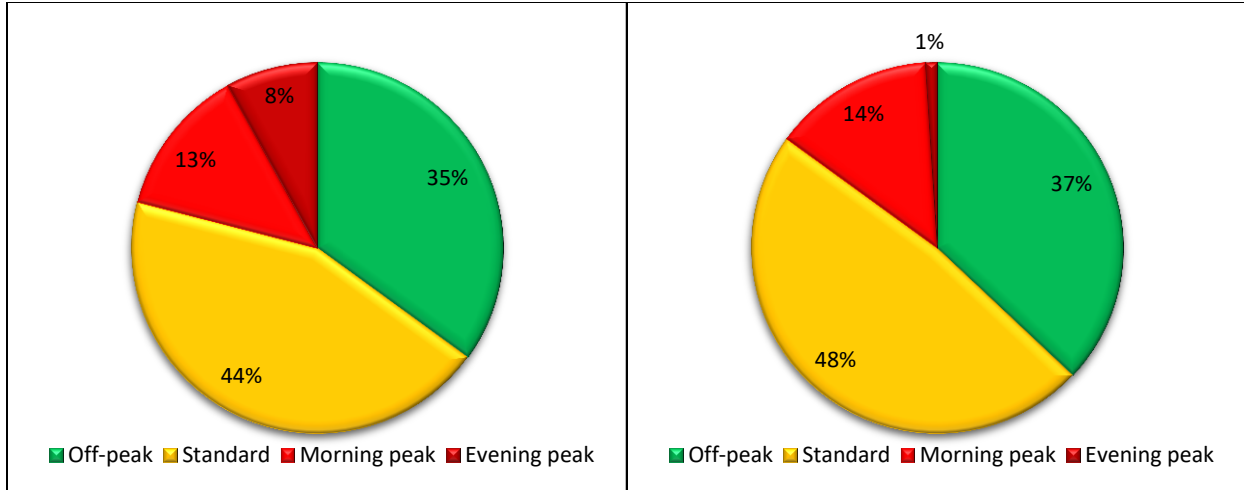

Figure 4 - 22: Mine B surface cooling system baseline

Figure 4 - 21: Mine B surface cooling surface system actual

The electricity cost calculated using the Eskom’s Megaflex Tariff structure and the Time-of-Use for the two period periods (baseline and actual) is shown in Figure 4 - 23. Figure 4 - 21 illustrates the effect on load reduction during the Eskom’s expensive evening peak period on the electricity cost. The 24-hour electricity cost data can be found in Appendix 3.

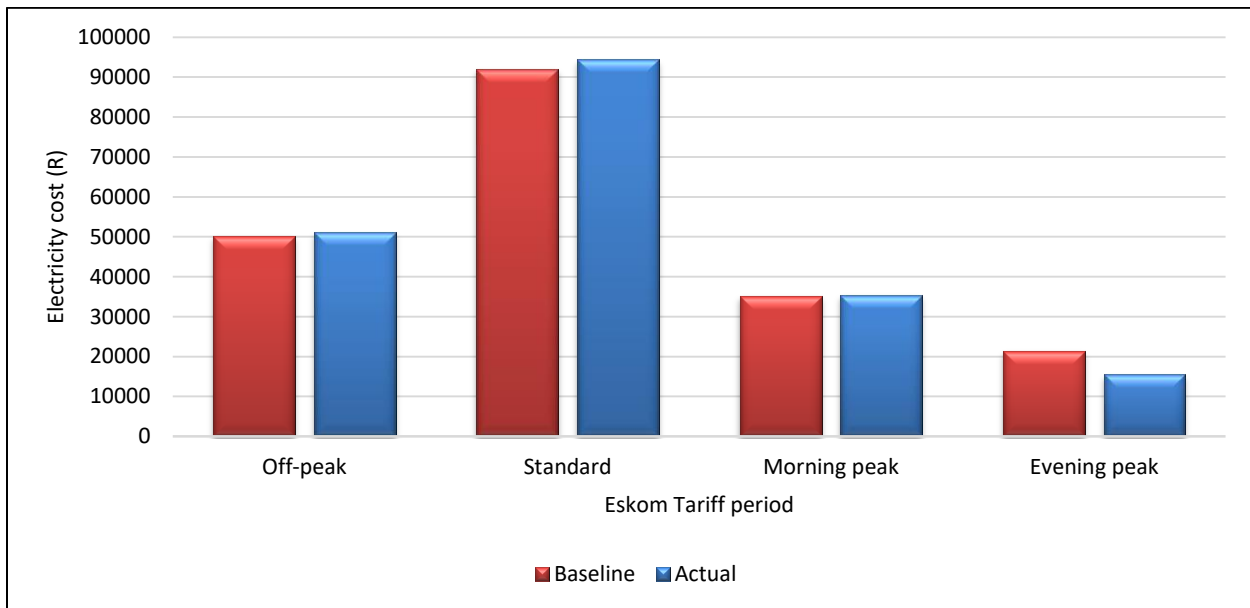

Figure 4 - 23: Mine B average daily electricity cost

4.4 Conclusion

The load management strategy that was developed in Chapter 3, the implementation is described in this chapter. The strategy was implemented on two case studies: Mine A with a surface closed loop system and Mine B with a semi-closed loop system. VSDs were installed on both systems to vary the flow to meet the cooling demand, resulting in energy efficiency on the systems.

The aim of this study is to achieve more electricity cost and energy savings on the mine surface cooling systems. The underground conditions, i.e. temperature and relative humidity, are closely monitored on a daily basis. The underground air WB temperatures at Mine A of 95 and 100 levels remain below the maximum set limit of 25.5°C WB. The temperatures at 110 level surpass the limit by 3.3%; however, this excess is below 5%, therefore, the strategy may remain implemented and continue to achieve electricity cost savings for the mine.

During the implementation phase at Mine B, the water temperature fed to the hard ice plants and the anti-surge increased rapidly. The other set of fridge plants (Top fridge plants), which feed the 8 ML dam, are used to supply cold water during the peak period to the hard ice plants and the anti-surge. The temperatures of the underground BACs inlet air WB temperatures remain below the maximum set limit of 25.5°C WB.

An average of 1.8 MW is being achieved at Mine A with annual cost savings of R900 000. And average of 2.7 MW is being achieved at Mine B with annual cost savings of R1.4 million. The developed load management strategy is versatile and can be implemented on any closed or semi-closed loop mine surface cooling system.

5. Conclusion and recommendations

Chapter 5 summarises the key findings of this study and it provides recommendations based on the study's outcomes.



⁹ A typical South African deep-level shaft.

Chapter 5: Conclusion and recommendations

5.1 Summary of the study

The mining industry in South Africa consumes approximately 14% of the total generated electricity capacity. The South African gold mines are the deepest in the world, reaching depths up to 4 km below surface. These deep-level mines require large cooling systems to maintain acceptable working conditions. Increasingly, up to 25% of the mine's total electricity is consumed by these large cooling systems. The mines require more DSM initiatives to achieve more electricity cost savings.

These electricity cost savings can be achieved by incorporating energy management strategies with the Eskom TOU. The Eskom TOU Tariff structures have the highest charging rate in the morning and evening peak periods for Megaflex users. The deep-level gold mines which are under Megaflex Tariff structure can achieve electricity cost savings by implementing DSM initiatives which aid to achieve load reduction on the energy-intensive machinery during the evening peak period.

The surface cooling systems of the deep-level gold mines with DSM initiatives implemented were investigated to identify more cost and energy saving opportunities. These DSM initiatives made use of the VSDs to vary and to control the water flow to meet the cooling demand. This varying of the water flow rates result in energy efficiency, however these DSM initiatives do not include monitoring of the underground working conditions, i.e. temperature and relative humidity. Therefore, this presented an opportunity to achieve load reduction on the surface cooling systems while monitoring the underground working conditions.

A load management strategy that incorporates the monitoring of the underground working conditions was developed. The underground working conditions are monitored with the installed permanent temperature and relative humidity sensors. Load reduction tests were conducted on Mine A (closed loop) and Mine B (semi-closed loop) surface cooling systems to verify the developed load management strategy. The underground WB temperatures remained below the

maximum set limit of 25.5°C WB during the tests. Therefore, the developed load management strategy can be implemented without adversely affecting the underground working conditions.

The WB underground temperatures at Mine A for all three levels (95L, 100L and 110L) vary between 23.0°C WB and 27.0°C WB after implementation. The maximum temperature of 26.4°C WB was reached at 110L, this temperature surpasses the maximum limit of 25.5°C WB by 0.9°C WB. The mine personnel did not complain about this temperature because at the lower mining levels, the maximum set limit is 27.5°C WB.

Whereas the underground BACs inlet air WB temperature on 84 level varies between 17.0°C WB and 21.0°C WB at Mine B. These WB temperatures are within the normal operational safety boundaries of the mines. Therefore, these temperatures for both case studies are allowable and the surface cooling systems can continually be switched off during the evening peak period to achieve load reduction, which results in electricity cost savings.

The BAC fans are left running during the evening peak period for mine ventilation systems on mines used in both case studies. At the preference of the mine personnel; the evaporator pumps at Mine B are also left running during the evening peak. Therefore, the load reduction can continuously be achieved on the mines surface cooling systems during the Eskom's expensive evening peak period.

An average load reduction of 1.8 MW was achieved over three months at Mine A with annual electricity cost savings of R900 000. Three months average of 2.7 MW was achieved at Mine B with annual electricity cost savings of R1.4 million. The electricity cost savings are calculated based on the 2016/2017 Eskom's Megaflex Tariff structure. The developed load management strategy is versatile and can be implemented to any closed and/or semi-closed loop mine surface cooling system. The objective of this study has been achieved.

5.2 Recommendations

The rerouting to supply the hard ice plants and the anti-surge (sub-systems) with cold water from the 8 ML dam (additional cold water source) is used to make the developed strategy successful. However, the opening and closing of valves is currently done manually, hence the three valves need to be automated in order to achieve sustainable savings. This gives an opportunity to study the cost implication of this automation and the sustainability of the electricity cost savings.

The ambient conditions were not taken into consideration to see the effect it has on the mine surface cooling system. A study that focuses on the effect of ambient conditions on the surface cooling system can be conducted.

The mine surface cooling system only has an effect down to the shallow levels the shaft. A study can be done to see the possibility of decommissioning one surface fridge plant while monitoring the underground conditions at the deeper mining levels.

6. References



¹⁰

¹⁰ A library picture. Source: <http://bsumc.blogspot.co.za/>

- [1] R. Inglesi-Lotz and A. Pouris, “Energy efficiency in South Africa: A decomposition exercise.” *Energy*, 2013, vol. 42, pp. 113-120.
- [2] J. Brune, “History of Research in Mine Refrigeration, Cooling and Ventilation in South Africa.” *Society for Mining, Metallurgy, and Exploration, Inc*, 2010, pp. 424-431.
- [3] G. E. du Plessis, L. Liebenberg and E. H. Mathews, “The use of variable speed drives for cost-effective energy savings in South African mine cooling systems.” *Applied Energy*, 2013, vol. 111, pp. 16-27.
- [4] B. Lin and P. K. Wesseh, “Energy consumption and economic growth in South Africa reexamined: A nonparametric testing approach.” *Renewable and Sustainable Energy Reviews*, 2014, vol. 40, pp. 840-850.
- [5] World Energy Council, “2015 World Energy Issues Monitor.” World Energy Council, London, 2015.
- [6] International Institute for Sustainable Development, “Sustainable Development.” International Institute for Sustainable Development, 2002. [Online]. Available: <https://www.iisd.org/sd/>. [Accessed 04 June 2015].
- [7] M. Kohler, “Differential electricity pricing and energy efficiency in South Africa.” *Energy*, 2014, vol. 64, pp. 524-532.
- [8] R. Inglesi-Lotz and J. N. Blignaut, “South Africa's electricity consumption: A sectoral decomposition analysis.” *Applied Energy*, 2011, vol. 88, pp. 4779-4784.
- [9] Eskom, “Eskom.” Eskom, 2011. [Online]. Available: <http://www.eskom.co.za/>. [Accessed 2 June 2015].

- [10] R. R. Kumar and R. Kumar, “Effect of energy consumption on per worker output: A study of Kenya and South Africa.” *Energy Policy*, 2013, vol. 62, pp. 1187-1193.
- [11] Department of Energy, “Basic electricity.” Department of Energy, 2016. [Online]. Available: <http://www.energy.gov.za/files/>. [Accessed 15 July 2016].
- [12] BusinessTech, “SA electricity prices vs Africa vs the world.” BusinessTech, 2014. [Online]. Available: <http://businesstech.co.za/news/>. [Accessed 15 July 2016].
- [13] J. Vosloo, L. Liebenberg and D. Velleman, “Case study: Energy savings for a deep-mine water reticulation system.” *Applied Energy*, 2012, pp. 328-335.
- [14] InfoMine, “Canada gold mines.” InfoMine, 2016. [Online]. Available: <http://www.mining.com/>. [Accessed 15 July 2016].
- [15] S. J. Bluhm, W. M. Marx, R. Ramsden and F. H. Glehn, “History of Research in Mine Refrigeration, Cooling, and Ventilation.” in *Extracting the science: A Century of Mining Research*, Johannesburg, 2010, pp. 424-431.
- [16] B. J. Glaister and G. M. Mudd, “The environmental costs of platinum-PGM mining and sustainability: Is the glass half-full or half-empty?” *Minerals Engineering*, 2010, vol. 23, pp. 438-450.
- [17] D. Del Castillo, “Air cycle refrigeration system for cooling mines.” *International Journal of Refrigeration*, 1988, vol. 11, no. 2, pp. 87-91.
- [18] J. Calitz, “Research and implementation of a load reduction system for a mine refrigeration system.” M.Eng. dissertation, North-West University, Potchefstroom, 2006.
- [19] J. J. du Plessis, W. M. Marx and C. Nell, “Efficient use of energy in the ventilation and cooling of mines.” *The Southern African Institute of Mining and Metallurgy*, 2014, vol. 114, pp. 1033-1037.

- [20] M. De-jun, S. Xiu-hua and Z. Sheng-zhu, “Adequate air volume in working face after mechanical refrigeration.” *Safety Science*, 2012, pp. 705-708.
- [21] N. Thorp and S. J. Bluhm, “The use of small cooling plants on a mine.” *Southern African Institute of Mining and Metallurgy*, 1986, vol. 86, no. 2, pp. 61-66.
- [22] D. Stephenson, “Distribution of water in deep gold mines in South Africa.” *International Journal of Mine Water*, 1983, vol. 2, no. 2, pp. 21-30.
- [23] G. E. Du Plessis, L. Liebenberg, E. H. Mathews and J. N. Du Plessis, “A versatile energy management system for large integrated cooling systems.” *Energy Conversion and Management*, 2013, vol. 66, pp. 312-325.
- [24] T. J. Sheer, P. F. Cilliers, E. G. Chaplain and R. M. Correia, “Some recent developments in the use of ice for cooling mines.” *Journal of Ventilation Society of South Africa*, 1985, vol. 38, no. 5, pp. 56-59.
- [25] D. Mitchell and A. Whillier, “Cooling power of underground environment.” *Journal of the Southern African Institute of Mining and Metallurgy*, 1971, pp. 93-99.
- [26] D. F. Grave and R. M. Stroh, “The planning of Ventilation and Refrigeration requirements in Deep Mines.” *Southern African Institute of Mining and Metallurgy*, 1972, pp. 171-186.
- [27] A. J. Schutte, “An integrated energy efficiency strategy for deep mine ventilation and refrigeration.” Ph.D. thesis, North-West University, Potchefstroom campus, Potchefstroom, 2014.
- [28] ASHRAE, “HVAC applications.” in *ASHRAE Handbook*, Atlanta, 2011, pp. 29.1-29.13.
- [29] F. W. Stoecker, Refrigeration and air conditioning, McGraw-Hill Publishing Company, 1983.

- [30] G. Pingye, W. Yanwei, D. Mengmeng, P. Donyang and L. Nan, “Research and application of methods for effectiveness evaluation of mine cooling system.” *International Journal of Mining Science and Technology*, 2015, vol. 25, pp. 649-654.
- [31] J. van der Walt and E. M. De Kock, “Developments in the engineering of refrigeration installations for cooling mines.” *International Journal of Refrigeration*, 1984, vol. 7, no. 1, pp. 27-40.
- [32] H. E. Man-chao, “Application of HEMS cooling technology in deep mine heat hazard control.” *Mining Science and Technology*, 2009, p. 19.
- [33] D. van Greunen, “Energy efficiency through variable speed drive control on a cascading mine cooling system.” M.Eng dissertation, North-West University, Potchefstroom, 2014.
- [34] A. J. Schutte, “Demand-side energy management of a cascade mine surface refrigeration system.” M.Eng. dissertation, North-West University, Potchefstroom, 2007.
- [35] S. van Jaarsveld, “A control system for the efficient operation of bulk air coolers on a mine.” M.Eng dissertation, North-West University, Potchefstroom, 2014.
- [36] C. Swart, “Optimising the operation of underground mine refrigeration plants and ventilation fans for minimum electricity cost.” Ph.D. thesis, North-West University, Potchefstroom, 2003.
- [37] E. L. Strydom-Bouwer, “DSM opportunities in underground refrigeration systems.” M.Eng. dissertation, North-West University, Potchefstroom, 2008.
- [38] A. Chatterjee, L. Zhang and X. Xia, “Optimization of mine ventilation fan speeds according to ventilation on demand and time of use Tariff.” *Applied Energy*, 2015, vol. 146, pp. 65-73.

- [39] D. Gordić, M. Babić, N. Jović, V. Šušteršič, D. Končalović, and D. Jelić, “Development of energy management system – Case study of Serbian car manufacturer.” *Energy Conversion and Management*, 2010, vol. 51, pp. 5783-5790.
- [40] M. A. Zehir and M. Bagriyanik, “Demand Side Management by controlling refrigerators and its effect on consumers.” *Energy Conversion and Management*, 2012, vol. 64, pp. 238-244.
- [41] M. M. Eissa, “Demand side management program evaluation based on industrial and commercial field data.” *Energy Policy*, 2011, vol. 39, pp. 5961-5969.
- [42] C. Cilliers, “Cost savings on mine dewatering pumps by reducing preparation- and comeback loads.” M.Eng. dissertation, North-West University, Potchefstroom, 2013.
- [43] J. L. Buys, “Optimising the refrigeration and cooling system of a platinum mine.” M.Eng. dissertation, North-West University, Potchefstroom, 2014.
- [44] G. E. Du Plessis, “A variable water flow strategy for energy savings in large cooling systems.” Ph.D. thesis, North-West University, Potchefstroom, 2013.
- [45] D. C. Uys, “Converting an ice storage facility to a chilled water system for energy efficiency on a deep level gold mine.” M.Eng. dissertation, North-West University, Potchefstroom, 2014.
- [46] A. M. Holman, “Benefits of improved performance monitoring of mine cooling systems.” M.Eng. dissertation, North-West University, Potchefstroom, 2014.
- [47] G. E. Du Plessis, D. C. Arndt and E. H. Mathews, “The development and integrated simulation of a variable water flow energy saving strategy for deep-mine cooling systems.” *Sustainable Energy Technologies and Assessments*, 2015, vol. 10, pp. 71-78.

- [48] J. C. Vosloo, “Control of an underground rock winder system to reduce electricity costs on RSA gold mines.” M.Eng. dissertation, North-West University, Potchefstroom, 2006.
- [49] M. A. Buthelezi, “Load shift through optimal control of complex underground rock winders.” M.Eng. dissertation, North-West University, Potchefstroom, 2009.
- [50] P. H. Bosman, “The control of rock winders for maximum demand management on deep South African mines.” M.Eng. dissertation, North-West University, Potchefstroom, 2006.
- [51] J. C. Vosloo, “A new minimum cost model for water reticulation systems on deep mines.” Ph.D. thesis, North-West University, Potchefstroom, 2008.
- [52] R. P. Richter, “Comparison between automated and manual DSM pumping projects.” M.Eng. dissertation, North-West University, Potchefstroom, 2008.
- [53] S. W. Van Heerden, “Developing a dynamic control system for mine compressed air networks.” Ph.D. thesis, North-West University, Potchefstroom, 2014.
- [54] J. P. Spangenberg, “Analysing the effect of DSM projects at South African cement factories.” M.Eng. dissertation, North-West University, Potchefstroom, 2015.
- [55] H. J. Groenewald, “A performance-centered maintenance strategy for industrial DSM projects.” Ph.D. thesis, North-West University, Potchefstroom, 2015.
- [56] R. Stull, “Wet-bulb temperature from relative humidity and air temperature.” *Journal of Applied Meteorology and Climatology*, 2011, vol. 50, pp. 2267-2269.

7. Appendices

7.1 Appendix 1 – Temperature profiles

Appendix 1 - Figure 1 shows the temperature trends of different mining levels at Mine B during the load reduction tests. The surface cooling system power consumption during the test is shown in the figure.

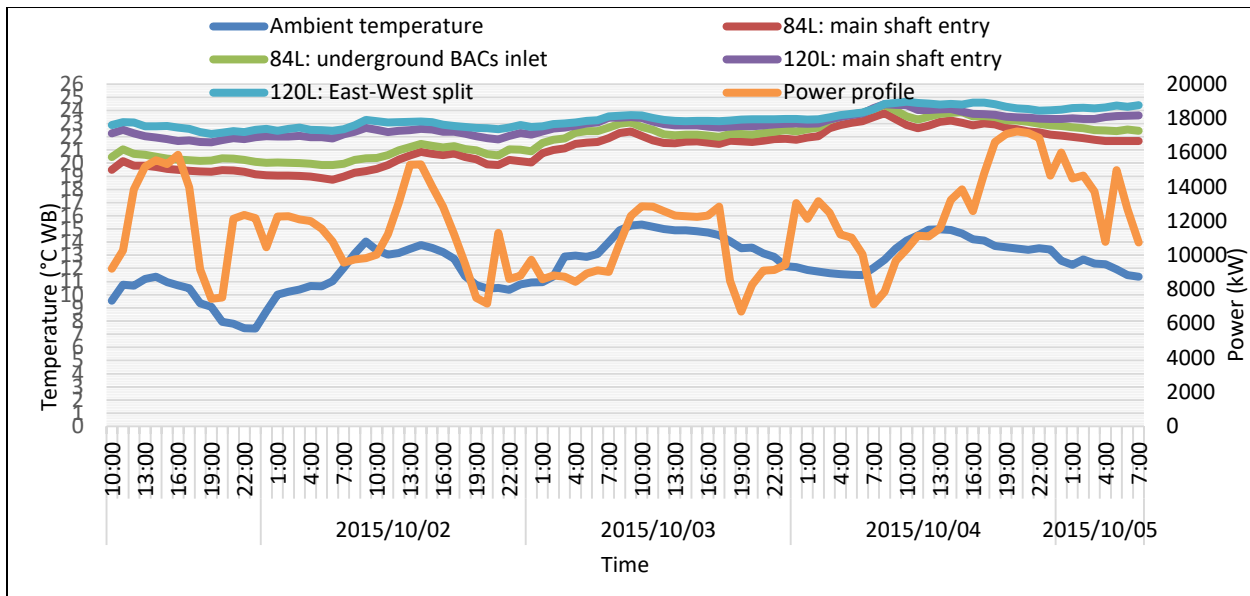

Appendix 1 - Figure 1: Temperature and power profiles during an offload test at Mine B

7.2 Appendix 2 – Power profiles data

Baselines

Appendix 2 - Table 1 shows the Mine A and Mine B power baseline that was used to calculate the load reduction achieved. It can clearly be seen that there is no load reduction taking place during the evening peak period, highlighted in red. These power readings also motivated the mines for the implementation of the developed load management strategy.

Appendix 2 - Table 1: Mine A and Mine B power baseline data

Time	Mine A (kW)	Mine B (kW)
00:00	3024	17565
01:00	3047	17966
02:00	3079	18065
03:00	2952	18301
04:00	3106	18080
05:00	2982	17997
06:00	2913	17576
07:00	2966	16228
08:00	3219	15306
09:00	3491	15439
10:00	3487	16666
11:00	3549	19306
12:00	3610	20066
13:00	3724	20489
14:00	3600	20586
15:00	3656	20536
16:00	3325	20105
17:00	3231	19445
18:00	3263	16605
19:00	3242	14898
20:00	3360	14883
21:00	3337	15609
22:00	3272	16596
23:00	3142	17110

Load reduction tests

Appendix 2 - Table 2 shows the Mine A and Mine B load reduction data after conducting the tests to determine the feasibility and safety effects of the developed load management strategy. The load reduction can clearly be seen that has taken place during the evening peak period. This load reduction is feasible as the electricity costs were reduced considerably.

Appendix 2 - Table 2: Mine A and Mine B load reduction tests data

Time	Mine A (kW)	Mine B (kW)
00:00	2884	9740
01:00	2835	8591
02:00	2786	8825
03:00	2667	87461
04:00	2636	8442
05:00	2671	8922
06:00	2718	9119
07:00	2769	9029
08:00	2841	10686
09:00	2951	12296
10:00	3061	12852
11:00	3164	12831
12:00	3275	12584
13:00	3327	12307
14:00	3350	12274
15:00	3382	12250
16:00	3313	12309
17:00	3026	12834
18:00	1443	8492
19:00	1410	6699
20:00	2884	8270
21:00	3280	9092
22:00	3137	9136
23:00	3002	9437

Actual consumption post-implementation

Appendix 2 - Table 3 shows the Mine A and Mine B average actual power consumption three months after the implementation of the strategy. The effect of the strategy can clearly be seen on the data during the Eskom expensive evening peak period.

Appendix 2 - Table 3: Mine A and Mine B actual power consumption

Time	Mine A (kW)	Mine B (kW)
00:00	3491	14651
01:00	3639	14203
02:00	3630	14103
03:00	3560	14538
04:00	3411	14878
05:00	3469	14609
06:00	3678	13487
07:00	3683	11563
08:00	3698	11936
09:00	3646	12762
10:00	3653	15003
11:00	3711	16488
12:00	3631	16856
13:00	3936	17023
14:00	3775	16986
15:00	3989	16474
16:00	4095	15824
17:00	4139	14211
18:00	2544	8659
19:00	1293	8656
20:00	2374	12936
21:00	3841	15028
22:00	3839	15217
23:00	3675	14795

7.3 Appendix 3 – Electricity cost

Appendix 3 - Table 1 shows the Mine A and Mine B electricity cost before and after the strategy implementation. These costs are calculated based on the Eskom Megaflex Tariff structure for 2016/2017. The costs are calculated for the power data shown in Appendix 2 - Table 1 and Appendix 2 - Table 3. These are the average daily electricity costs of each mine.

Appendix 3 - Table 1: Mine A and Mine B electricity cost before and after implementation

Time	Mine A		Mine B	
	Baseline electricity cost	Actual electricity cost	Baseline electricity cost	Actual electricity cost
00:00	R 1,354	R 1,370	R 5,587	R 5,748
01:00	R 1,326	R 1,428	R 5,667	R 5,572
02:00	R 1,318	R 1,424	R 5,722	R 5,533
03:00	R 1,304	R 1,397	R 5,731	R 5,704
04:00	R 1,284	R 1,338	R 5,688	R 5,837
05:00	R 1,274	R 1,361	R 5,558	R 5,731
06:00	R 1,266	R 1,443	R 5,464	R 5,291
07:00	R 2,047	R 2,267	R 7,559	R 7,116
08:00	R 3,061	R 3,298	R 10,934	R 10,645
09:00	R 3,026	R 3,252	R 11,217	R 11,382
10:00	R 3,081	R 3,258	R 13,021	R 13,380
11:00	R 3,044	R 3,075	R 9,762	R 10,147
12:00	R 3,100	R 3,009	R 10,006	R 10,374
13:00	R 3,089	R 3,262	R 10,165	R 10,476
14:00	R 3,091	R 3,128	R 10,130	R 10,454
15:00	R 3,086	R 3,306	R 10,059	R 10,138
16:00	R 3,113	R 3,393	R 9,769	R 9,738
17:00	R 3,082	R 3,430	R 9,166	R 8,746
18:00	R 3,319	R 2,269	R 10,765	R 7,723
19:00	R 3,195	R 1,154	R 10,608	R 7,720
20:00	R 2,961	R 1,968	R 7,493	R 7,961
21:00	R 2,928	R 3,183	R 7,936	R 9,249
22:00	R 1,390	R 1,506	R 5,326	R 5,970
23:00	R 1,380	R 1,442	R 5,442	R 5,804